

Introduction	Knoll and Sustainable Design	3
	General Specifications	4
	Reff Profiles finish options	5
	Reff Profiles Master Features	7
Panels	Monolithic panels 34" H	10
	Monolithic panels 42" H	16
	Monolithic panels 49" H	23
	Monolithic panels 64" H	30
	Monolithic panels 79" H	37
	Tiled panels 34" H	44
	Tiled panels 42" H	49
	Tiled panels 49" H	56
	Tiled panels 64" H	63
	Tiled panels 79" H	70
	Aluminum Reveal kits	77
	Beltway one side, window panel 49" H	84
	Beltway two sides, window panel 49" H	98
	Stacking modules	100
	Panel connection posts	105
	Panel trims and post covers	110
	Ceiling cable entry posts, poles and cable infeed	112
	Ceiling cable entry post covers	114
	Rolling door and hinged door	116
	Attachment kits	117
	Floor to ceiling modules	118
	Required components	125
Power distribution components	126	
Beltway electrical components	131	
Data and Communications	133	
Reff Ported Panel Components	134	
Worksurfaces	Worksurface 1 1/4"	137
	Conference 1 1/4"	151
	Optional edge details 1 1/4"	153
	Optional edge 1 1/4"	154
	Waterfall Edge 1 1/4"	169
	Cascade Edge 1 1/4"	188
	Worksurface 1 1/2"	194
	Worksurface Credenza	197
	Peninsula 1 1/2"	200
	Tables, 1 1/2"	226
	Tables, 1"	233
Support components	Top support components	236
	Modesty	250
Cabinetry	Pedestals, 26 1/2" planning	255
	Pedestals, 28 3/8" planning	267
	Pedestals, Mobile	280
	Credenzas, 28 3/8" planning	281
	Cabinets, 26 1/2" planning	286
	Cabinets, 28 3/8" planning	311
	Cabinets Progressive	333
Desktop towers	Desktop Towers	345

Overhead storage	Overhead, 26 <sup>1</sup> / <sub>2</sub> " planning	352
	Overhead, 28 <sup>3</sup> / <sub>8</sub> " planning	361
	Reuter overhead cabinet	390
	Reuter open shelf	393
	Reuter open overhead	394
	Reuter overhead storage	395
	Task Lights for Reuter Overhead Storage	397
	Progressive Overheads	398
Transaction tops, regular and waterfall edge	Transaction tops	407
Gallery desk surrounds	Gallery desk surrounds	409
Preconfigured Reff Desking	Single pedestal desks	413
	Double pedestal desks	414
	Desk returns	415
	Single pedestal credenzas	416
	Bridge assemblies	417
	Double pedestal credenzas	418
Accessories and Client Samples	Accessories	419
	Task Panels	433
	Tackboards	477
	Desk Screens	482
	Cubbies	491
Reff Original finish options	Reff Original finish options	493
Wall Mounting of Knoll Products		494
Horizons Planning	Horizons - 28 <sup>3</sup> / <sub>8</sub> " Planning	496
Alpha-Numeric Index		499
Selling Policy		521
KnollKey Lock Program		523
General Ordering Information		524

# Knoll and Sustainable Design

---

Each year Knoll sets key initiatives in our journey to sustainability. We are members of a global consortium on energy, have adopted a scientific, metrics-based approach to sustainable product design, and maintain a leadership position in establishing universal, verifiable, sustainability standards for our industry.

Knoll promotes independent third-party certification because it provides the most impartial and trustworthy foundation for industry-wide environmental compliance. Certification by established and respected third parties ensures that all manufacturers are held to the same high standards and that customers can trust a company's declaration about the environmental benefits of its products. Knoll third-party partners include: the International Standards Organization (ISO); Forest Stewardship Council (FSC®); Rainforest Alliance; GREENGUARD® Environmental Institute; and The Business and Institutional Furniture Manufacturer's Association (BIFMA) level™ certification from Scientific Certification Systems (SCS).

In addition, Knoll is aligned with the U.S. Green Building Council and can help companies, healthcare organizations and educational institutions achieve Leadership in Energy and Environmental Design (LEED®) workplace certification.

## Global Climate Change

- Knoll is a sponsor of the Clinton Global Initiative, which brings together a community of global leaders to devise and implement solutions to some of the world's most pressing challenges, including environmental change.
- Knoll has a comprehensive Energy Management Program to increase energy efficiency in products and processes.

## Life Cycle Assessment (LCA) Tool

- Life Cycle Assessment is a science-based measurement of a product's environmental impacts throughout its life cycle, from raw materials sourcing through manufacture, shipping, use and re-use or end-of-life. LCA enables cradle-to-cradle implementation of sustainable practices.
- Knoll has partnered with The Green Standard.org to develop an affordable, universal ISO-compliant computer-based LCA tool that can be used by the entire contract furniture industry and is partnering on the development of an Environmental Product Declaration System (EPDs) for Knoll products. EPDs are verified documents containing LCA results and additional environmental performance information about a product.

## Setting Industry Standards

- Knoll partners with MTS (The Institute for Market Transformation to Sustainability) to develop the SMaRT® Consensus Sustainable Products Standards, a set of consensus-based sustainable product standards based on the LEED® model, for all building products, fabric, apparel, flooring and carpet. MTS, the developer of SMaRT®, is an accredited American National Standards Institute (ANSI) standard developer.
- Knoll also partners with BIFMA (Business and Institutional Furniture Manufacturers Association) to promote level™ sustainability standards for the contract furniture industry.
- Knoll has established FSC® (Forest Stewardship Council) certified wood as the standard for general office open plan office systems, casegoods and tables.
- Knoll has launched Full Circle, a resource recovery program developed with ANEW, to help customers extend the life cycle of surplus furniture, fixtures and equipment (FF&E) in an economically, socially and environmentally responsible manner.
- Our goal is to encourage all manufacturers in the contract furniture industry and related industries to adopt standards that will lead to sustainable products and practices.

*For more information about Knoll and sustainable design, visit [knoll.com/environment](http://knoll.com/environment).*

### Panels and Parts

All panels have a concealed perimeter frame 1 1/2" x 2". Panels 42" wide and wider, other than window panels, have additional interior bracing.

Panel bases are 3 3/8" or 6 3/16" high with levellers at both ends. Snap-in panel side plates are provided with at least two lift-outs on each side of panels 30" to 48" wide; one lift-out on each side of panels 24" wide, unless no knockout option is requested (see Planning Guide for details). Acoustical panels can be specified with fabric on either side or fabric on one side and wood or laminate on the other. A laminated board septum is covered on both sides with acoustical fiberglass for fabric/fabric panels providing an NRC of .80 and STC of 22.

Window panels utilize tempered 4mm thick glass. Panel-to-panel connection is accomplished with a steel connector bar, which engages locking points on panel perimeter frames and is drawn tight by means of a screw mechanism located at the top of the bar. Each panel is supplied with one connector, which also serves as an anchor point for panel-hung support brackets. Panel-to-wall connection is accomplished with a PVC extrusion which connects two aluminum extrusions - one screwed to the wall, the other attached to the panel perimeter frame. Stacking panels are provided with a fastener feature which allows individual 15" and 30"H sections to be added or removed without disturbing the panel run. In all cases a leveller adjustable panel must first be specified with additional sections added on to provide height adjustment. A post is required at panel intersections, when a panel run changes direction or as in the case of the straight line post when it is required to make up an extra 2 1/2" to match another panel run. Top trim utilizes a PVC extrusion for a press fit into the panel perimeter frame. End trim is screwed to a steel connector bar which locks it to the panel perimeter frame.

All tiled panels are constructed using the same frame as monolithic panels and also use the same internal components. However, the insert structure has been altered to allow tiles 15"H to be independently applied to the panel, thus creating a tiled appearance. Tiled panels can be stacked on.

Reff panels can be joined to existing System 6, Classic System 6, and Segmented panels with a conversion kit.

Beltway electrical panel is a Reff panel altered to provide access to electrical and communication ports at a desk height level.

### Note:

**Line drawings in this price list are purely for quick product identification without any form of detail. One must not use the price list line drawings to satisfy production dimensions, shape or support options. Refer to Planning Guide for detailed product information.**

### Wood and Laminate Components

Tops are 1 3/4" or 1 1/4" thick. Undersides are pre-drilled with inserts and routed to accept pedestals and connecting hardware.

Flush and cantilever top assemblies have 1 1/16" thick endpanels, and 1 5/16" thick backpanels. Recessed top assemblies have 1 1/16" thick endpanels and a 1 5/16" thick backpanel.

Pedestals are supplied with metal channels on the top to attach the pedestal to the underside of a worksurface.

Drawer boxes can be specified in both metal or wood with dovetailed joinery. Hinge doors use concealed, adjustable hinges.

All components are veneered and finished on all sides unless otherwise specified. Edges are banded with 1/8" PVC or 3/32" solid wood. 1 3/4" laminate tops are postformed front and back. 2" Deep solid waterfall edge optional.

### Locks

All pedestals and cabinets with drawers are supplied with a ganglock mechanism in place. In addition, cabinets with drawers have a drawer interlock anti-tip device designed to prevent the opening of a second drawer when one is already open. Drawer fronts and door fronts are routed to receive the lock itself. Locks for drawers in pedestals and cabinets can be retro-fitted. Door locks are identical in shape to drawer locks, but these components are not pre-routed and therefore, locks cannot be retro-fitted.

Reff lockcores must be specified separately. Reff lock mechanisms are black and feature a removable core for easy replacement.

### Levellers

All endpanels, backpanels (except recessed), floor pedestals and cabinets have 1 1/2" high levellers.

### Lighting

Shelves and overhead cabinets have a bottom recess to house the task light. The task light can be easily retro-fitted.

Power is conveyed to the task light fixture by a 9' long cable. The lower end of the cable can be plugged into a panel base receptacle.

### Grommets

Grommets are optional (except where noted). Tops up to 48" wide have one grommet. Tops wider than 48" include two grommets. See Planning Guide for locations.

**All dimensions in this price list are for representative purposes only. For accurate build dimensions or factory drawings, please call Customer Services.**

The Reff electrical is listed for use in the Reff panel system under UL1286.

Reff "Floor to Ceiling" is a modular, panel-based system. The ceiling channel should not be used as a support for the panel (see support section of specification guide).

**Because local building and electrical codes vary and may have special requirements for modular walls that touch, approach or are attached to the ceiling, customers and installers should have the specifications reviewed and approved by building inspectors and a qualified electrical contractor. To the extent local codes and practices dictate, Knoll is available to help with customized solutions.**

Orders with 50 or fewer locks required with no specific keying requests will be sent randomly keyed by the factory without warning.

### Finishing

All Reff natural wood veneer and Techwood components are stained and sealed using a state of the art polyurethane finishing process. Polyur<sup>TM</sup> provides superior resistance to solvents, stains, abrasion and heat. Each component is coated and cured with ultraviolet light for a durable, lasting wood surface.

Natural veneers are all hand selected to best showcase the beauty of natural grain and to Knoll's meticulous color and grain standards.

Every effort is made to ensure that Knoll Reff veneers are the best that can be sourced in quality of color, consistency and size. Natural variations of wood are held in high regard and are not considered to be defects. Natural variations are not subject to warranty. The natural process of color change in real wood products is part of the unique character and beauty of this material. Knoll expects wood to patina over time and does not warranty color change.

Techwood is a genuine real wood product, enhanced by technology to provide color and grain consistency. Techwood finishes are available in open and closed pore options. Open pore techwood finishes are not available on waterfall edge tops. Waterfall edge tops can be specified with closed pore V1 and V2 finishes only.

FSC (Forest Stewardship Council) certified materials available upon request.

**Wood Finishes:**

**V1 Techwood Closed Pore**

Y316	Maple
Y319	Cherry
Y323	Medium Walnut
Y326	Dark Mahogany
Y327	Light Oak
Y329	Medium Oak
Y341	Wenge *
Y342	Medium Teak *
Y343	Dark Grey Oak *
Y344	Espresso
Y851	Black Oak
Y811	Natural
Y821	Blond Maple
Y831	Light Cherry

\*Not available on Reff optional Edges and Waterfall Edge.

**V1 - Techwood Closed Pore**

**Surface with matching synthetic edge:**

Options applicable for 1/4" thick worksurfaces with standard flat edge only.

S319	Cherry
S316	Maple
S323	Medium Walnut

**V2 Natural Veneers/Premium**

**Techwood Veneers**

**Closed Pore**

V312	Bronze Cherry
V316	Maple
V411	Light Walnut
V415	Peacock Green Walnut
V417	Old English Walnut
V418	Smoked Walnut
V433	Light Fawn Cherry
V436	Medium Brown Cherry
V440	Natural Hemlock (QC)
Y871	Iced Sycamore (Open pore)
Y841	Ebony (Open pore)
Y861	Grigio (Open pore)

(all above V2's are flat cut)

V421	Chalk Oak
V423	Light Oak
V425	Amber Oak
V427	Brown Oak

(all V2 Oak's are rift cut)

V439	Straight Anigre
------	-----------------

**V2 Natural Veneer with synthetic edge**

Options applicable for 1/4" thick worksurfaces with standard flat edge only.

**Flat Cut:**

R319	Medium Cherry
R315	Light Cherry
R316	Light Maple
R323	Medium Walnut
R415	Peacock Green Walnut
R417	Old English Walnut
R421	Chalk Oak
R427	Brown Oak
R312	Bronze Cherry

**V3 Exotic Veneer**

V512	Figured Anigre
V514	Makore
V515	Figured Sycamore
V517	Natural Sapele
V518	Natural Chestnut

(all above are quarter cut)

**Glass Options:**

TEMP	Clear Tempered (G1)
------	---------------------

*Architectural Glass Options: (G2)*

GL13	Powder
GL8	Wafer
GL6	Block Matrix

*Back Painted Glass (G3)*

GL11	Back Painted Black
GL15	Back Painted Medium Grey
GL18	Back Painted White

*Colored Glass (G3)*

GL35	Grey
GL85	Star Clear

**Locks**

Black and Silver

**Laminate**

Matching edge band unless noted otherwise

111	Jet Black
114	Folkstone Grey
115	Medium Grey
117	Soft Grey
118	Bright White
119	Pumice
121	Micro Grey with 114 Folkstone grey edge band
122	Brushed Sand with 119 Pumice edge band
123	Brushed Grey with 128 Fog edge band
124	Medium Chery
125	Natural Maple
126	Natural Cherry
127	Walnut
128	Fog
129	Micro Sand with 119 Pumice edge band

**Paint Classifications:**

Upcharge as applicable for paint class noted on applicable product pages

**P1**

111	Jet Black
112	Brown
113	Dark Grey
114	Folkstone Grey
115	Medium Grey
116	Sandstone
117	Soft Grey

**P2**

611	Beige Mist Metallic
612	Medium Metallic Grey

**P3**

118	Bright White
613	Silver
PD	Polish Chrome
PT	Brushed Pewter
PN	Black Nickel
PU	Satin Nickel
AN	Anodized Black
AP	Anodized Polished
AU	Anodized Satin
AA	Anodized Aluminum

See matrix next page for finishes applicable by component

**Forbo**

851	Biscuit
852	Sky Blue
853	Stone
854	Cinnamon
855	Heather Blue

**Mixed Finishes: (where applicable for work surfaces only)**

To order mixed finishes, enter four digit finish code as follows:

Use 2 digit prefix to indicate surface finish (laminate)

11	Jet Black
14	Folkstone Grey
17	Soft Grey
18	Bright White
19	Pumice
21	Micro Grey
22	Brushed Sand
23	Brushed Grey
28	Fog
29	Micro Sand

Use 2 digit suffix to indicate edge finish (wood)

12	for V312
16	for V316, Y316
Y9	for Y319
Y3	for Y323
26	for Y326
27	for Y327
29	for Y329
43	for V433
45	for V415
46	for V436
47	for V417
48	for V418
49	for V439
52	for V512
54	for V514
55	for V515
57	for V517
61	for V411
71	for V421
73	for V423
75	for V425
77	for V427
85	for Y851
Y1	for Y341
62	for Y342
44	for Y344

**Example:**

For a Micro Grey laminate surface with Bronzed Cherry edge, enter finish code 2112

For a Jet Black laminate surface with Light Maple edge, enter finish code 1116

**Fabric Options**

*Grade 10*

Bailey II (W359) ø  
 Broadcloth (W288)  
 Foundation (W351)  
 Growth Spurt (W692)  
 Newbury (W812) ø  
 Solid Crepe (W257) ø  
 Symbolic Detail (W693)  
 Tailor Made (W133)  
 Versatility (W432)

*Grade 15*

Regency (W210)

*Grade 20*

Banyan (W443)  
 Bauhaus Block (W296A)  
 Circle Line (W1146)  
 Clarity (W281)  
 Criss Cross (W305)  
 Devon (W809) ø  
 Labyrinth (W352)  
 Melbourne (W228)  
 Outback (W229)  
 Reflect (W884) ø  
 Resolution (W280)  
 Walkabout (W230)  
 Weave Three (W298)

*Grade 30*

Basket Draft (W249)  
 Flow (W565)  
 Harmony (W232)  
 Interknit (W1090)  
 Match Point (W1145)  
 Micro (W465)\*  
 Progression (W403)  
 Raku Cloth (W566) ø  
 Relay (W1020) ▲

*Grade 40*

Clarkson (W1218)  
 Ornament (W1078)  
 Palladium (W1030)  
 Sennit (W337)  
 Spinoff Nuance (W319)

*Grade 45*

Casual Elegance (W920)  
 Dristi (K872)\* ø

*\*with backing only*

▲ Monolithic panels and tackboards only

ø May not be available in all colors.

*The following textiles are approved for use on Reff panels. Consult Knoll representative for pricing:*

*Grade 50*

Knoll Hopsack (K1206)  
 Ricochet (W498)

*Grade 55*

Knoll Felt (K1207)  
 Transition (W816)

**Customers Own Material**

Prices for panels that are to be manufactured with a customer supplied fabric will follow Grade 10 panel pricing.

COM fabrics are subject to a testing charge prior to acceptance for use on Reff panels. Panels bearing COM fabrics are subject to extended leadtimes. It is the responsibility of the customer's purchasing agent to ensure COM fabric is supplied for testing and manufacturing. Delays in receiving COM fabric for manufacturing will result in rescheduled delivery dates.

When specifying panel/fabrics use the following format to denote location on a tiled panel.

Side 1		Side 2
1E	Top of Panel	2E
1D		2D
1C		2C
1B		2B
1A	Bottom of Panel	2A

(Side 1 is always the inside of the workstation.)

Panels with beltway one side: assume the beltway is on SIDE 1 of the panel.

**Non-Wood Finishes**

**26 1/2" h planning Finishes**

	<i>Panel Tiles, Worksurfaces &amp; Components</i>	<i>Panel Top Trims Window Frames</i>	<i>Panel Base Side Plates</i>	<i>Panel Beltway Side Plates*</i>	<i>Leg and Bases</i>	<i>Interaction Style Legs</i>	<i>Pulls</i>	<i>Grommets</i>
Jet Black	111	111	111	111	111	111	111	111
Dark grey	n/a	113	113	113	113	113	n/a	113
Medium grey	n/a	115	115	115	115	115	n/a	115
Soft grey	117	117	117	117	117	117	n/a	117
Folkstone grey	114	114	114	114	114	114	n/a	114
Pumice	119	119	119	119	119	119	n/a	119
Sandstone	n/a	116	116	116	116	116	n/a	116
Brown	n/a	112	112	112	112	112	112	112
Medium metallic grey	n/a	612	612	612	612	612	612	612
Silver	n/a	613	613	613	613	613	613	613
Bright White	118	118	118	118	118	118	118	118
Beige metallic mist	n/a	611	611	611	611	611	611	611
Micro Grey *	121	n/a	n/a	n/a	n/a	n/a	n/a	n/a
Brushed Sand *	122	n/a	n/a	n/a	n/a	n/a	n/a	n/a
Brushed Grey *	123	n/a	n/a	n/a	n/a	n/a	n/a	n/a
Fog	128	n/a	n/a	n/a	n/a	n/a	n/a	n/a
Micro Sand *	129	n/a	n/a	n/a	n/a	n/a	n/a	n/a

**Plated Finishes**

Satin brass	n/a	n/a	PZ	n/a	PZ	n/a	PZ	PZ
Brushed pewter	n/a	n/a	PT	n/a	PT	n/a	PT	PT
Polished chrome	n/a	n/a	PD	n/a	PD	n/a	n/a	PD

n/a = not available

\* = matching edge band not available, also not optional for panel tiles or components, worksurfaces only

---

## Panel Trim Profiles

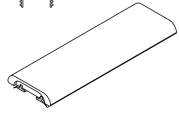

Flat (Option A)

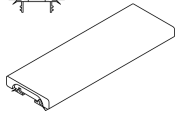

Square (Option B)

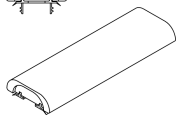

Bullnose (Option C)

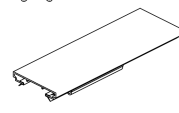

Extruded Aluminum (Option E)

## Worksurface Profiles



1 1/2" and 1 1/4" Thick Standard

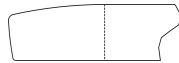

1 1/4" Thick Waterfall



1 1/4" Thick Cascade

**NOTE:** See page 153 for 7 Optional Edges which are also available.

---

## Pull Options

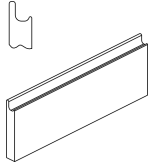

Integral Wood J-Pull

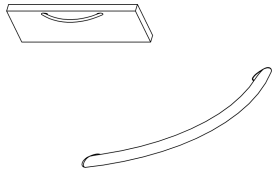

C-Pull (Nickle Plated Finish Only)  
7<sup>3</sup>/<sub>8</sub>"W x 1<sup>5</sup>/<sub>32</sub>"D

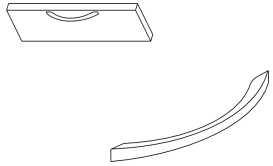

S-Pull (Stainless Steel Finish Only)  
6<sup>5</sup>/<sub>32</sub>"W x 1<sup>1</sup>/<sub>16</sub>"D

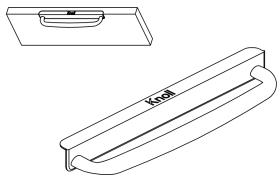

D-Pull (Painted and Plated Finishes)  
7<sup>3</sup>/<sub>4</sub>"W x 1<sup>13</sup>/<sub>32</sub>"D



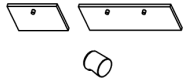

*R-Cylinder*

1" diameter  
 Protrudes 1" from the drawer front  
 Available in painted and plated finishes  
 1 pull per 16" & 19" wide pedestal drawer  
 Position: center position for 16" & 19" drawers  
 2 pulls per 30" & 36" lateral drawers  
 Position: 6" in from end, 1 1/2" down from top of drawers

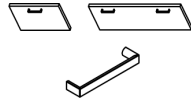

*H-Out Line*

4" wide x 1" deep  
 Protrudes 1" from the drawer front  
 Available in painted and plated finishes  
 1 pull per 16" & 19" wide pedestal drawer  
 Position: center, 1 1/2" down from the top of drawer  
 2 pulls per 30" & 36" lateral drawers  
 Position: 6" in from left/right, 1 1/2" down from top of drawers

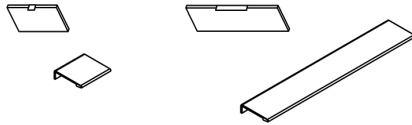

*T-Tab*

short Tab: 2" wide x 1 3/4" deep  
 Long Tab: 10" wide x 1 3/4" deep  
 Protrudes 3/4" from drawer front  
 Available in painted or plated finishes  
 Position: Center line position on drawers

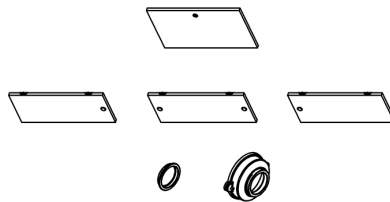

*G-Grommet Pull*

1 5/32" diameter  
 Flush with the drawer front  
 Available in painted and plated finishes  
 1 pull per 60" & 72" sliding doors  
 Position: 1.656" from left or right, center line vertical  
 2 pulls per 90" & 108" sliding doors  
 Position: 1.656" from left and right, center line vertical

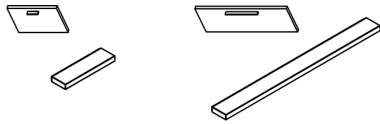

*F-Bar Pull*

Short bar pull: 3 3/8" wide x .3" thick  
 Long bar pull: 10 1/2" wide x .3" thick  
 Protrudes 1" from drawer front  
 Available in painted and plated finishes  
 Position: Center line position on drawers

# Monolithic panels 34" H fabric both sides

description	w	h	pattern no.	grade						
				10	15	20	30	35	40	45
Monolithic, fabric both sides	18"	34"	<b>R3B0PFF34 18-</b> ( ) ( )	\$589.	\$605.	\$645.	\$729.	\$779.	\$855.	\$907.
Regular acoustics	20"	34"	<b>R3B0PFF34 20-</b> ( ) ( )	589.	605.	645.	729.	779.	855.	907.
	24"	34"	<b>R3B0PFF34 24-</b> ( ) ( )	635.	651.	691.	775.	825.	901.	953.
	30"	34"	<b>R3B0PFF34 30-</b> ( ) ( )	678.	694.	734.	818.	868.	944.	996.
	36"	34"	<b>R3B0PFF34 36-</b> ( ) ( )	721.	737.	777.	861.	911.	987.	1,039.
	42"	34"	<b>R3B0PFF34 42-</b> ( ) ( )	827.	843.	883.	967.	1,017.	1,093.	1,145.
	48"	34"	<b>R3B0PFF34 48-</b> ( ) ( )	859.	875.	915.	999.	1,049.	1,125.	1,177.

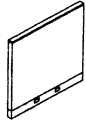

### Order Code

Example:	<b>R3B0PFF3418-A4K</b>
<b>R3</b>	Reff Generation 3
<b>B0</b>	No Beltway
<b>P</b>	Monolithic panel
<b>FF</b>	Fabric on both sides
<b>34</b>	34" high
<b>18</b>	18" wide
<b>(A)</b>	Flat style top trim profile
<b>(4)</b>	4" base height
<b>(K)</b>	Include knockouts in base
<b>W281</b>	Fabric Side 1
<b>W281</b>	Fabric Side 2
<b>V316</b>	Maple (top trim finish)
<b>111</b>	Jet Black (base finish)
<b>M</b>	Milled for ported components

### Specification Information

To order please specify pattern number including:

1. Top trim profile
2. Base height
3. Knockout option  
(K = with knockouts, N = without knockouts)
4. Panel side 1 finish(s) inside
5. Panel side 2 finish(s) outside
6. Top trim finish  
i) Top trim profile A,B or C options:  
V1, V2, V3, P1, P2, P3 finishes  
ii) Top trim profile E options:  
AA-anodized aluminum or P1, P2, P3 finish listed on page 5 excluding silver
7. Base finish
8. *Optional*: specify (M) for panel frame to be milled for ported components. \$14 list upcharge applicable

### Application Notes

1. Top trim profile:  
A = Flat  
B = Square  
C = Bullnose  
E = Extruded aluminum
2. Base height:  
4 = 4" base height  
6 = 6" base height (add \$47 per panel for this option)

Applicable finishes are listed on page 5 and 6.

All panels on this page accept stacking modules.

6" Raceway option increases panel height by 2<sup>3</sup>/<sub>4</sub>".

All panels on this page have no high acoustical option or Beltway option.

Product on this page can be attached to posts 34"H, other 34", 42", 49", 64", and 79" panels without beltway. To attach 34"H panels to Beltway posts over 34"H, order appropriate attachment kit from page 117.

79"H hookstrip reveal strips are ordered separately from page 117 at no charge.

Ported panel components to be installed below worksurface if panel 36"h.

# Monolithic panels 34" H

*fabric one side, laminate other side*

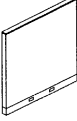
description	w	h	pattern no.	grade						
				10	15	20	30	35	40	45
Monolithic, fabric one side Regular acoustics 	18"	34"	<b>R3B0PFL34 18-( ) ( )</b>	\$563.	\$571.	\$589.	\$626.	\$649.	\$681.	\$705.
	20"	34"	<b>R3B0PFL34 20-( ) ( )</b>	563.	571.	589.	626.	649.	681.	705.
	24"	34"	<b>R3B0PFL34 24-( ) ( )</b>	599.	607.	625.	662.	685.	717.	741.
	30"	34"	<b>R3B0PFL34 30-( ) ( )</b>	639.	647.	665.	702.	725.	757.	781.
	36"	34"	<b>R3B0PFL34 36-( ) ( )</b>	674.	682.	700.	737.	760.	792.	816.
	42"	34"	<b>R3B0PFL34 42-( ) ( )</b>	767.	775.	793.	830.	853.	885.	909.
	48"	34"	<b>R3B0PFL34 48-( ) ( )</b>	790.	798.	816.	853.	876.	908.	932.

**Order Code**

Example:	<b>R3B0PFL3418-A4K</b>
<b>R3</b>	Reff Generation 3
<b>B0</b>	No Beltway
<b>P</b>	Monolithic panel
<b>FL</b>	Fabric one side
<b>34</b>	34" high
<b>18</b>	18" wide
<b>A</b>	Flat style top trim profile
<b>4</b>	4" base height
<b>K</b>	Include knockouts in base
<b>W281</b>	Fabric Side 1
<b>114</b>	Folkstone grey - side 2
<b>V316</b>	Maple (top trim finish)
<b>111</b>	Jet Black (base finish)
<b>M</b>	Milled for ported components

**Specification Information**

*To order please specify pattern number including:*

1. Top trim profile
2. Base height
3. Knockout option (K = with knockouts, N = without knockouts)
4. Panel side 1 finish(s) inside
5. Panel side 2 finish(s) outside
6. Top trim finish  
i) Top trim profile A,B or C options:  
V1, V2, V3, P1, P2, P3 finishes  
ii) Top trim profile E options:  
AA-anodized aluminum or P1, P2, P3 finish listed on page 5 excluding silver
7. Base finish
8. *Optional:* specify (M) for panel frame to be milled for ported components. \$14 list upcharge applicable

*1. Top trim profile:*

A = Flat  
B = Square  
C = Bullnose  
E = Extruded Aluminum

*2. Base height:*

4 = 4" base height  
6 = 6" base height (add \$47 per panel for this option).

Applicable finishes are listed on page 5 and 6.

Product on this page will accept wood grain laminate where laminate is currently an option. Panel product is subject to a 10% upcharge on the base panel price. Refer to panel product upcharge table.

**Application Notes**

All panels on this page accept stacking modules.

6" Raceway option increases panel height by 2<sup>3</sup>/<sub>4</sub>".

All panels on this page have no high acoustical option or Beltway option.

Product on this page can be attached to posts 34"H, other 34", 42", 49", 64", and 79" panels without beltway. To attach 34"H panels to Beltway posts over 34"H, order appropriate attachment kit from page 117.

79"H hookstrip reveal strips are ordered separately from page 117 at no charge.

Ported panel components to be installed below worksurface if panel 36"h.

# Monolithic panels 34" H

*fabric one side, techwood other side*

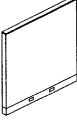
description	w	h	pattern no.	grade						
				10	15	20	30	35	40	45
Monolithic, fabric one side	18"	34"	<b>R3B0PF134 18-()()</b>	\$661.	\$668.	\$689.	\$731.	\$757.	\$795.	\$823.
Regular acoustics	20"	34"	<b>R3B0PF134 20-()()</b>	664.	671.	692.	734.	760.	798.	826.
	24"	34"	<b>R3B0PF134 24-()()</b>	707.	714.	735.	777.	803.	841.	869.
	30"	34"	<b>R3B0PF134 30-()()</b>	752.	759.	780.	822.	848.	886.	914.
	36"	34"	<b>R3B0PF134 36-()()</b>	797.	804.	825.	867.	893.	931.	959.
	42"	34"	<b>R3B0PF134 42-()()</b>	904.	911.	932.	974.	1,000.	1,038.	1,066.
	48"	34"	<b>R3B0PF134 48-()()</b>	934.	941.	962.	1,004.	1,030.	1,068.	1,096.

### Order Code

Example:	<b>R3B0PF13418-A4K</b>
<b>R3</b>	Reff Generation 3
<b>B0</b>	No Beltway
<b>P</b>	Monolithic panel
<b>F1</b>	Fabric one side, V1 other side
<b>34</b>	34" high
<b>18</b>	18" wide
<b>A</b>	Flat style top trim profile
<b>4</b>	4" base height
<b>K</b>	Include knockouts in base
<b>W281</b>	Fabric Side 1
<b>Y328</b>	Mahogany - side 2
<b>V316</b>	Maple (top trim finish)
<b>111</b>	Jet Black (base finish)
<b>M</b>	Optional milled frame

### Specification Information

*To order please specify pattern number including:*

1. Top trim profile
2. Base height
3. Knockout option (K = with knockouts, N = without knockouts)
4. Panel side 1 finish(s) inside
5. Panel side 2 finish(s) outside
6. Top trim finish
  - i) Top trim profile A,B or C options: V1, V2, V3, P1, P2, P3 finishes
  - ii) Top trim profile E options: AA-anodized aluminum or P1, P2, P3 finish listed on page 5 excluding silver
7. Base finish
8. *Optional:* specify (M) for panel frame to be milled for ported components. \$14 list upcharge applicable

### Application Notes

1. *Top trim profile:*  
A = Flat  
B = Square  
C = Bullnose  
E = Extruded Aluminum
2. *Base height:*  
4 = 4" base height  
6 = 6" base height (add \$47 per panel for this option)

Applicable finishes are listed on page 5 and 6.

All panels on this page accept stacking modules.

6" Raceway option increases panel height by 2<sup>3</sup>/<sub>4</sub>".

All panels on this page have no high acoustical option or Beltway option.

Product on this page can be attached to posts 34"H, other 34", 42", 49", 64", and 79" panels without beltway. To attach 34"H panels to Beltway posts over 34"H, order appropriate attachment kit from page 117.

79"H hookstrip reveal strips are ordered separately from page 117 at no charge.

Ported panel components to be installed below worksurface if panel 34"h.

# Monolithic panels 34" H

*fabric one side, conventional veneer other side*

description	w	h	pattern no.	grade						
				10	15	20	30	35	40	45
Monolithic, fabric one side	18"	34"	<b>R3B0PF234 18-()</b> ( )	\$674.	\$681.	\$702.	\$744.	\$770.	\$808.	\$836.
Regular acoustics	20"	34"	<b>R3B0PF234 20-()</b> ( )	677.	684.	705.	747.	773.	811.	839.
	24"	34"	<b>R3B0PF234 24-()</b> ( )	719.	726.	747.	789.	815.	853.	881.
	30"	34"	<b>R3B0PF234 30-()</b> ( )	767.	774.	795.	837.	863.	901.	929.
	36"	34"	<b>R3B0PF234 36-()</b> ( )	811.	818.	839.	881.	907.	945.	973.
	42"	34"	<b>R3B0PF234 42-()</b> ( )	924.	931.	952.	994.	1,020.	1,058.	1,086.
	48"	34"	<b>R3B0PF234 48-()</b> ( )	952.	959.	980.	1,022.	1,048.	1,086.	1,114.

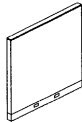

### Order Code

Example:	<b>R3B0PF23418-A4K</b>
<b>R3</b>	Reff Generation 3
<b>B0</b>	No Beltway
<b>P</b>	Monolithic panel
<b>F2</b>	Fabric one side, V2 other side
<b>34</b>	34" high
<b>18</b>	18" wide
<b>A</b>	Flat style top trim profile
<b>4</b>	4" base height
<b>K</b>	Include knockouts in base
<b>W281</b>	Fabric Side 1
<b>V316</b>	Maple surface - side 2
<b>V316</b>	Maple (top trim finish)
<b>111</b>	Jet Black (base finish)
<b>M</b>	Optional milled frame

### Specification Information

*To order please specify pattern number including:*

1. Top trim profile
2. Base height
3. Knockout option (K = with knockouts, N = without knockouts)
4. Panel side 1 finish(s) inside
5. Panel side 2 finish(s) outside
6. Top trim finish
  - i) Top trim profile A, B or C options: V1, V2, V3, P1, P2, P3 finishes
  - ii) Top trim profile E options: AA-anodized aluminum or P1, P2, P3 finish listed on page 5 excluding silver
7. Base finish
8. *Optional:* specify (M) for panel frame to be milled for ported components. \$14 list upcharge applicable

*1. Top trim profile:*  
 A = Flat  
 B = Square  
 C = Bullnose  
 E = Extruded aluminum

*2. Base height:*  
 4 = 4" base height  
 6 = 6" base height (add \$47 per panel for this option)

Applicable finishes are listed on page 5 and 6.

### Application Notes

All panels on this page accept stacking modules.

6" Raceway option increases panel height by 2<sup>3</sup>/<sub>4</sub>".

All panels on this page have no high acoustical option or Beltway option.

Product on this page can be attached to posts 34"H, other 34", 42", 49", 64", and 79" panels without beltway. To attach 34"H panels to Beltway posts over 34"H, order appropriate attachment kit from page 117.

79"H hookstrip reveal strips are ordered separately from page 117 at no charge.

Ported panel components to be installed below worksurface if panel 34"h.

# Monolithic panels 34" H

*fabric one side, exotic veneer other side*

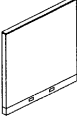
description	w	h	pattern no.	grade						
				10	15	20	30	35	40	45
Monolithic, fabric one side	18"	34"	<b>R3B0PF334 18-()</b> ( )	\$896.	\$903.	\$924.	\$966.	\$992.	\$1,030.	\$1,058.
Regular acoustics	20"	34"	<b>R3B0PF334 20-()</b> ( )	900.	907.	928.	970.	996.	1,034.	1,062.
	24"	34"	<b>R3B0PF334 24-()</b> ( )	957.	964.	985.	1,027.	1,053.	1,091.	1,119.
	30"	34"	<b>R3B0PF334 30-()</b> ( )	1,023.	1,030.	1,051.	1,093.	1,119.	1,157.	1,185.
	36"	34"	<b>R3B0PF334 36-()</b> ( )	1,081.	1,088.	1,109.	1,151.	1,177.	1,215.	1,243.
	42"	34"	<b>R3B0PF334 42-()</b> ( )	1,233.	1,240.	1,261.	1,304.	1,329.	1,367.	1,395.
	48"	34"	<b>R3B0PF334 48-()</b> ( )	1,270.	1,277.	1,298.	1,340.	1,366.	1,404.	1,432.

Order Code	Specification Information	Application Notes
Example: <b>R3B0PF33418-A4K</b>	<i>To order please specify pattern number including:</i>	<i>1. Top trim profile:</i>
<b>R3</b> Reff Generation 3	1. Top trim profile	A = Flat
<b>B0</b> No Beltway	2. Base height	B = Square
<b>P</b> Monolithic panel	3. Knockout option	C = Bullnose
<b>F3</b> Fabric one side, V3 one side	(K = with knockouts, N = without knockouts)	E = Extruded aluminum
<b>34</b> 34" high	4. Panel side 1 finish(s) inside	<i>2. Base height:</i>
<b>18</b> 18" wide	5. Panel side 2 finish(s) outside	4 = 4" base height
<b>A</b> Flat style top trim profile	6. Top trim finish	6 = 6" base height (add \$47 per panel for this option)
<b>4</b> 4" base height	i) Top trim profile A,B or C options:	Applicable finishes are listed on page 5 and 6.
<b>K</b> Include knockouts in base	V1, V2, V3, P1, P2, P3 finishes	
<b>W281</b> Fabric Side 1	ii) Top trim profile E options:	
<b>V512</b> Figured Anigre surface - side 2	AA-anodized aluminum or P1, P2, P3 finish listed on page 5 excluding silver	
<b>V512</b> Figured Anigre (top trim finish)	7. Base finish	
<b>111</b> Jet Black (base finish)	8. <i>Optional:</i> specify (M) for panel frame to be milled for ported components. \$14 list upcharge applicable	
<b>M</b> Optional milled frame		

# Monolithic panels 34" H

## Laminate/Laminate

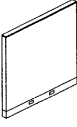
description	w	h	pattern no.	L
Monolithic, laminate both sides with raceway both sides 	18"	34"	<b>R3B0PLL3418</b> ( ) ( )	\$578.
	20"	34"	<b>R3B0PLL3420</b> ( ) ( )	578.
	24"	34"	<b>R3B0PLL3424</b> ( ) ( )	630.
	30"	34"	<b>R3B0PLL3430</b> ( ) ( )	706.
	36"	34"	<b>R3B0PLL3436</b> ( ) ( )	763.
	42"	34"	<b>R3B0PLL3442</b> ( ) ( )	786.
	48"	34"	<b>R3B0PLL3448</b> ( ) ( )	823.

Order Code	Specification Information	Application Notes	
Example: <b>R3B0PLL3418-A4K</b> <b>R3</b> Reff Generation 3 <b>B0</b> No Beltway <b>P</b> Monolithic panel <b>LL</b> Laminate both sides <b>34</b> 34" high <b>18</b> 18" wide <b>A</b> Flat style top trim profile <b>4</b> 4" base height <b>K</b> Include knockouts in base <b>118</b> Laminate - side 1 <b>118</b> Laminate - side 2 <b>V512</b> Figured Anigre (top trim finish) <b>111</b> Jet Black (base finish) <b>M</b> Optional milled frame	To order please specify pattern number including: 1. Top trim profile 2. Base height 3. Knockout option (K = with knockouts, N = without knockouts) 4. Panel side 1 laminate inside 5. Panel side 2 laminate outside 6. Top trim finish i) Top trim profile A, B or C options: V1, V2, V3, P1, P2, P3 finishes ii) Top trim profile E options: AA-anodized aluminum or P1, P2, P3 finish listed on page 5 excluding silver 7. Base finish 8. <i>Optional:</i> specify (M) for panel frame to be milled for ported components. \$14 list upcharge applicable	1. <i>Top trim profile:</i> A = Flat B = Square C = Bullnose E = Extruded aluminum  2. <i>Base height:</i> 4 = 4" base height  Applicable finishes are listed on page 5 and 6.  Product on this page will accept wood grain laminate where laminate is currently an option. Panel product is subject to a 10% upcharge on the base panel price. Refer to panel product upcharge table.	All panels on this page accept stacking modules.  6" Raceway option increases panel height by 2 3/4".  All panels on this page have no high acoustical option or Beltway option.  Product on this page can be attached to posts 34"H, other 34", 42", 49", 64", and 79" panels without beltway. To attach 34"H panels to Beltway posts over 34"H, order appropriate attachment kit from page 117.  79"H hookstrip reveal strips are ordered separately from page 117 at no charge.  Ported panel components to be installed below worksurface if panel 34"h.

# Monolithic panels 42" H fabric both sides

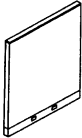
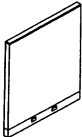
description	w	h	pattern no.	grade						
				10	15	20	30	35	40	45
Monolithic, fabric both sides	18"	42"	<b>R3B0PFF42 18-()</b> ( )	\$537.	\$553.	\$597.	\$685.	\$753.	\$831.	\$885.
Regular acoustics	20"	42"	<b>R3B0PFF42 20-()</b> ( )	537.	553.	597.	685.	753.	831.	885.
	24"	42"	<b>R3B0PFF42 24-()</b> ( )	573.	589.	633.	721.	789.	867.	921.
	30"	42"	<b>R3B0PFF42 30-()</b> ( )	624.	640.	684.	772.	840.	918.	972.
	36"	42"	<b>R3B0PFF42 36-()</b> ( )	672.	688.	732.	820.	888.	966.	1,020.
	42"	42"	<b>R3B0PFF42 42-()</b> ( )	721.	737.	781.	869.	937.	1,015.	1,069.
	48"	42"	<b>R3B0PFF42 48-()</b> ( )	774.	790.	834.	922.	990.	1,068.	1,122.
	60"	42"	<b>R3B0PFF42 60-()</b> ( ) *	874.	922.	1,010.	1,182.	1,308.	1,472.	1,572.
	66"	42"	<b>R3B0PFF42 66-()</b> ( ) *	905.	953.	1,041.	1,213.	1,339.	1,503.	1,603.
	72"	42"	<b>R3B0PFF42 72-()</b> ( ) *	934.	982.	1,070.	1,242.	1,368.	1,532.	1,632.
Monolithic, fabric both sides	18"	42"	<b>R3B0PAA42 18-()</b> ( )	589.	605.	649.	737.	805.	883.	937.
High acoustics	20"	42"	<b>R3B0PAA42 20-()</b> ( )	589.	605.	649.	737.	805.	883.	937.
	24"	42"	<b>R3B0PAA42 24-()</b> ( )	627.	643.	687.	775.	843.	921.	975.
	30"	42"	<b>R3B0PAA42 30-()</b> ( )	680.	696.	740.	828.	896.	974.	1,028.
	36"	42"	<b>R3B0PAA42 36-()</b> ( )	736.	752.	796.	884.	952.	1,030.	1,084.
	42"	42"	<b>R3B0PAA42 42-()</b> ( )	793.	809.	853.	941.	1,009.	1,087.	1,141.
	48"	42"	<b>R3B0PAA42 48-()</b> ( )	850.	866.	910.	998.	1,066.	1,144.	1,198.
	60"	42"	<b>R3B0PAA42 60-()</b> ( ) *	954.	1,002.	1,090.	1,262.	1,388.	1,552.	1,652.
	66"	42"	<b>R3B0PAA42 66-()</b> ( ) *	986.	1,034.	1,122.	1,294.	1,420.	1,584.	1,684.
	72"	42"	<b>R3B0PAA42 72-()</b> ( ) *	1,018.	1,066.	1,154.	1,326.	1,452.	1,616.	1,716.

Order Code	Specification Information	Application Notes
Example: <b>R3B0PFF4218-A4K</b>	<i>To order please specify pattern number including:</i>	The Reff System does not support the stacking of modules onto 42"H panels. These panels can be used to achieve transaction top height (see page 407).
<b>R3</b> Reff Generation 3	1. Top trim profile	79"H hookstrip reveal strips are ordered separately from page 117 at no charge.
<b>B0</b> No Beltway	2. Base height	
<b>P</b> Monolithic panel	3. Knockout option (K = with knockouts, N = without knockouts)	6" Raceway option increases panel height by 2 3/4".
<b>FF</b> Fabric on both sides	4. Panel side 1 finish(s) inside	Product on this page can be attached to posts 42", 49", 64", and 79"H as well as panels 42", 49", 64" and 79"H. Panels on this page will not attach to panels made before April 1997 without an R2AK attachment kit from page 117.
<b>42</b> 42" high	5. Panel side 2 finish(s) outside	
<b>18</b> 18" wide	6. Top trim finish	Remember to specify Beltway paint finish when applicable.
<b>(A)</b> Flat style top trim profile	ii) Top trim profile A, B or C options: V1, V2, V3, P1, P2, P3 finishes	
<b>(4)</b> 4" base height	AA-anodized aluminum or P1, P2, P3 finish listed on page 5 excluding silver	*These panel widths do not accept stacking modules.
<b>(K)</b> Include knockouts in base	7. Base finish	*Fabric inserts of these panels are two pieces, split vertically.
<b>W281</b> Fabric - Side 1	8. <i>Optional:</i> specify (M) for panel frame to be milled for ported components. \$14 list upcharge applicable	
<b>W281</b> Fabric - Side 2		
<b>V316</b> Maple (top trim finish)		
<b>111</b> Jet Black (base finish)		
<b>M</b> Optional milled frame		
	1. <i>Top trim profile:</i> A = Flat B = Square C = Bullnose E = Extruded Aluminum	
	2. <i>Base height:</i> 4 = 4" base height 6 = 6" base height (add \$47 per panel for this option)	



# Monolithic panels 42" H with Beltway

description	w	h	pattern no.	grade						
				10	15	20	30	35	40	45
Monolithic, fabric both sides	18"	42"	<b>R3B2PFF42 18-( ) ( )</b>	\$1,057.	\$1,083.	\$1,141.	\$1,255.	\$1,323.	\$1,417.	\$1,483.
Beltway two sides, regular acoustics	20"	42"	<b>R3B2PFF42 20-( ) ( )</b>	1,057.	1,083.	1,141.	1,255.	1,323.	1,417.	1,483.
	24"	42"	<b>R3B2PFF42 24-( ) ( )</b>	1,079.	1,105.	1,163.	1,277.	1,345.	1,439.	1,505.
	30"	42"	<b>R3B2PFF42 30-( ) ( )</b>	1,132.	1,158.	1,216.	1,330.	1,398.	1,492.	1,558.
	36"	42"	<b>R3B2PFF42 36-( ) ( )</b>	1,324.	1,350.	1,408.	1,522.	1,590.	1,684.	1,750.
	42"	42"	<b>R3B2PFF42 42-( ) ( )</b>	1,424.	1,450.	1,508.	1,622.	1,690.	1,784.	1,850.
	48"	42"	<b>R3B2PFF42 48-( ) ( )</b>	1,475.	1,501.	1,559.	1,673.	1,741.	1,835.	1,901.
	Monolithic, fabric both sides	18"	42"	<b>R3B1PFF42 18-( ) ( )</b>	1,041.	1,062.	1,113.	1,214.	1,282.	1,368.
Beltway one side	20"	42"	<b>R3B1PFF42 20-( ) ( )</b>	1,041.	1,062.	1,113.	1,214.	1,282.	1,368.	1,428.
	24"	42"	<b>R3B1PFF42 24-( ) ( )</b>	1,059.	1,080.	1,131.	1,232.	1,300.	1,386.	1,446.
	30"	42"	<b>R3B1PFF42 30-( ) ( )</b>	1,112.	1,133.	1,184.	1,285.	1,353.	1,439.	1,499.
	36"	42"	<b>R3B1PFF42 36-( ) ( )</b>	1,300.	1,321.	1,372.	1,473.	1,541.	1,627.	1,687.
	42"	42"	<b>R3B1PFF42 42-( ) ( )</b>	1,398.	1,419.	1,470.	1,571.	1,639.	1,725.	1,785.
	48"	42"	<b>R3B1PFF42 48-( ) ( )</b>	1,442.	1,463.	1,514.	1,615.	1,683.	1,769.	1,829.

**Order Code**

**Specification Information**

**Application Notes**

Example: <b>R3B2PFF4218</b>
<b>R3</b> Reff Generation 3
<b>B2</b> Beltway two sides
<b>P</b> Monolithic panel
<b>FF</b> Fabric on both sides
<b>42</b> 42" high
<b>18</b> 18" wide
<b>(A)</b> Flat style top trim profile
<b>(4)</b> 4" base height
<b>(K)</b> Include knockouts in base
<b>W281</b> Fabric - Side 1 below belt
<b>W281</b> Fabric - Side 1 above belt
<b>W281</b> Fabric - Side 2 below belt
<b>W281</b> Fabric - Side 2 above belt
<b>V316</b> Maple (top trim finish)
<b>111</b> Jet Black (base finish)
<b>111</b> Jet Black Beltway finish

To order please specify pattern number including:

- Top trim profile
- Base height
- Knockout option (K = with knockouts, N = without knockouts)
- Panel side 1 finish(s) inside below belt
- Panel side 1 finish(s) inside above belt
- Panel side 2 finish(s) outside below belt
- Panel side 2 finish(s) outside above belt
- Top trim finish
  - Top trim profile A,B or C options: V1, V2, V3, P1, P2, P3 finishes
  - Top trim profile E options: AA-anodized aluminum or P1, P2, P3 finish listed on page 5 excluding silver
- Base finish
- Beltway finish
- Optional:* specify (M) for panel frame to be milled for ported components. \$14 list upcharge applicable

- Top trim profile:
  - A = Flat
  - B = Square
  - C = Bullnose
  - E = Extruded Aluminum
- Base height:
  - 4 = 4" base height
  - 6 = 6" base height (add \$47 per panel for this option)
- Beltway:
  - B1 = Beltway 1 side
  - B2 = Beltway 2 sides

The Reff System does not support the stacking of modules onto 42"H panels. These panels can be used to achieve transaction top height (see page 407).

6" Raceway option increases panel height by 2 3/4".

Product on this page can be attached to posts 42", 49", 64", and 79"H as well as panels 42", 49", 64" and 79"H. Panels on this page will not attach to panels made before April 1997 without an R2AK attachment kit from page 117.

Remember to specify Beltway paint finish when applicable.

\*These panel widths do not accept stacking modules.

\*Fabric inserts of these panels are two pieces, split vertically.

79"H hookstrip reveal strips are ordered separately from page 117 at no charge.

Applicable finishes are listed on page 5 and 6.

# Monolithic panels 42" H

*fabric one side, laminate other side*

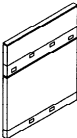
description	w	h	pattern no.	grade						
				10	15	20	30	35	40	45
Monolithic, fabric one side Regular acoustics 	18"	42"	<b>R3B0PFL42 18-( )()</b>	\$461.	\$469.	\$489.	\$526.	\$557.	\$591.	\$616.
	20"	42"	<b>R3B0PFL42 20-( )()</b>	461.	469.	489.	526.	557.	591.	616.
	24"	42"	<b>R3B0PFL42 24-( )()</b>	467.	475.	495.	532.	563.	597.	622.
	30"	42"	<b>R3B0PFL42 30-( )()</b>	560.	568.	588.	625.	656.	690.	715.
	36"	42"	<b>R3B0PFL42 36-( )()</b>	606.	614.	634.	671.	702.	736.	761.
	42"	42"	<b>R3B0PFL42 42-( )()</b>	681.	689.	709.	746.	777.	811.	836.
	48"	42"	<b>R3B0PFL42 48-( )()</b>	741.	749.	769.	806.	837.	871.	896.
	60"	42"	<b>R3B0PFL42 60-( )()</b>	805.	825.	863.	940.	996.	1,069.	1,113.
	66"	42"	<b>R3B0PFL42 66-( )()</b>	834.	854.	892.	969.	1,025.	1,098.	1,142.
	72"	42"	<b>R3B0PFL42 72-( )()</b>	865.	885.	923.	1,000.	1,056.	1,129.	1,173.
Monolithic, fabric one side Beltway one side (fabric side) 	18"	42"	<b>R3B1PFL42 18-( )()</b>	907.	919.	944.	994.	1,024.	1,066.	1,096.
	20"	42"	<b>R3B1PFL42 20-( )()</b>	907.	919.	944.	994.	1,024.	1,066.	1,096.
	24"	42"	<b>R3B1PFL42 24-( )()</b>	930.	942.	967.	1,017.	1,047.	1,089.	1,119.
	30"	42"	<b>R3B1PFL42 30-( )()</b>	1,000.	1,012.	1,037.	1,087.	1,117.	1,159.	1,189.
	36"	42"	<b>R3B1PFL42 36-( )()</b>	1,167.	1,179.	1,204.	1,254.	1,284.	1,326.	1,356.
	42"	42"	<b>R3B1PFL42 42-( )()</b>	1,194.	1,206.	1,231.	1,281.	1,311.	1,353.	1,383.
	48"	42"	<b>R3B1PFL42 48-( )()</b>	1,343.	1,355.	1,380.	1,430.	1,460.	1,502.	1,532.

Order Code	Specification Information	Application Notes
Example: <b>R3B0PFL4218-A4K</b> <b>R3</b> Reff Generation 3 <b>B0</b> No Beltway <b>P</b> Monolithic panel <b>FL</b> Fabric one side, laminate other <b>42</b> 42" high <b>18</b> 18" wide <b>A</b> Flat style top trim profile <b>4</b> 4" base height <b>K</b> Include knockouts in base <b>W281</b> Fabric - Side 1 <b>114</b> Folkstone grey - side 2 <b>V316</b> Maple (top trim finish) <b>111</b> Jet Black (base finish) <b>M</b> Optional milled frame	To order please specify pattern number including: B0=No Beltway B1=Beltway one side 1. Top trim profile 2. Base height 3. Knockout option (K = with knockouts, N = without knockouts) 4. Panel side 1 finish(s) inside (for panel with beltway specify: Side 1-below belt Side 2-above belt) 5. Panel side 2 finish(s) outside 6. Top trim finish i) Top trim profile A,B or C options: V1, V2, V3, P1, P2, P3 finishes ii) Top trim profile E options: AA-anodized aluminum or P1, P2, P3 finish listed on page 5 excluding silver 7. Base finish 8. Beltway finish-only for panel with beltway option 9. <i>Optional non-beltway panels:</i> specify (M) for panel frame to be milled for ported components, \$14 list upcharge applicable	1. <i>Top trim profile:</i> A = Flat B = Square C = Bullnose E = Extruded Aluminum 2. <i>Base height:</i> 4 = 4" base height 6 = 6" base height (add \$47 per panel for this option) 3. <i>Beltway:</i> B0 = No Beltway B1 = Beltway 1 side Applicable finishes are listed on page 5 and 6. Product on this page will accept wood grain laminate where laminate is currently an option. Panel product is subject to a 10% upcharge on the base panel price. Refer to panel product upcharge table. The Reff System does not support the stacking of modules onto 42"H panels. These panels can be used to achieve transaction top height (see transaction tops page.) 6" Raceway option increases panel height by 2 3/4". Product on this page can be attached to posts 42", 49", 64", and 79"H as well as panels 42", 49", 64" and 79"H. Panels on this page will not attach to panels made before April 1997 without an attachment kit from page 117. Remember to specify Beltway paint finish when applicable. 79"H hookstrip reveal strips are ordered separately from page 117 at no charge. Fabric and laminate covers of 60", 66" and 72" wide panels are two pieces, split vertically.

# Monolithic panels 42" H

*fabric one side, techwood other side*

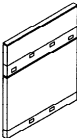
description	w	h	pattern no.	grade						
				10	15	20	30	35	40	45
Monolithic, fabric one side Regular acoustics 	18"	42"	<b>R3B0PF142 18-( )</b>	\$542.	\$551.	\$573.	\$618.	\$653.	\$692.	\$720.
	20"	42"	<b>R3B0PF142 20-( )</b>	542.	551.	573.	618.	653.	692.	720.
	24"	42"	<b>R3B0PF142 24-( )</b>	547.	556.	578.	623.	658.	697.	725.
	30"	42"	<b>R3B0PF142 30-( )</b>	659.	668.	690.	735.	770.	809.	837.
	36"	42"	<b>R3B0PF142 36-( )</b>	713.	722.	744.	789.	824.	863.	891.
	42"	42"	<b>R3B0PF142 42-( )</b>	803.	812.	834.	879.	914.	953.	981.
	48"	42"	<b>R3B0PF142 48-( )</b>	872.	881.	903.	948.	983.	1,022.	1,050.
	60"	42"	<b>R3B0PF142 60-( )*</b>	948.	971.	1,016.	1,105.	1,168.	1,254.	1,305.
	66"	42"	<b>R3B0PF142 66-( )*</b>	985.	1,008.	1,053.	1,142.	1,205.	1,291.	1,342.
	72"	42"	<b>R3B0PF142 72-( )*</b>	1,019.	1,042.	1,087.	1,176.	1,239.	1,325.	1,376.
Monolithic, fabric one side Beltway one side (fabric side) 	18"	42"	<b>R3B1PF142 18-( )</b>	1,063.	1,076.	1,105.	1,164.	1,196.	1,245.	1,280.
	20"	42"	<b>R3B1PF142 20-( )</b>	1,063.	1,076.	1,105.	1,164.	1,196.	1,245.	1,280.
	24"	42"	<b>R3B1PF142 24-( )</b>	1,094.	1,107.	1,136.	1,195.	1,227.	1,276.	1,311.
	30"	42"	<b>R3B1PF142 30-( )</b>	1,176.	1,189.	1,218.	1,277.	1,309.	1,358.	1,393.
	36"	42"	<b>R3B1PF142 36-( )</b>	1,368.	1,381.	1,410.	1,469.	1,501.	1,550.	1,585.
	42"	42"	<b>R3B1PF142 42-( )</b>	1,405.	1,418.	1,447.	1,506.	1,538.	1,587.	1,622.
	48"	42"	<b>R3B1PF142 48-( )</b>	1,581.	1,594.	1,623.	1,682.	1,714.	1,763.	1,798.

Order Code	Specification Information	Application Notes	
Example: <b>R3B0PF14218-A4K</b> <b>R3</b> Reff Generation 3 <b>B0</b> No Beltway <b>P</b> Monolithic panel <b>F1</b> Fabric one side, V1 other <b>42</b> 42" high <b>18</b> 18" wide <b>A</b> Flat style top trim profile <b>4</b> 4" base height <b>K</b> Include knockouts in base <b>W281</b> Fabric - Side 1 <b>Y328</b> Mahogany - side 2 <b>V316</b> Maple (top trim finish) <b>111</b> Jet Black (base finish)	To order please specify pattern number including: 1. Top trim profile 2. Base height 3. Knockout option (K = with knockouts, N = without knockouts) 4. Panel side 1 finish(s) inside For panels with Beltway specify: Side 1, Below belt Side 2, Above belt 5. Panel side 2 finish(s) outside 6. Top trim finish i) Top trim profile A, B or C options: V1, V2, V3, P1, P2, P3 finishes ii) Top trim profile E options: AA-anodized aluminum or P1, P2, P3 finish listed on page 5 excluding silver 7. Base finish 8. Beltway finish (only for panels with Beltway) 9. <i>Optional non-beltway panels:</i> specify (M) for panel frame to be milled for ported components, \$14 list upcharge applicable	1. <i>Top trim profile:</i> A = Flat B = Square C = Bullnose E = Extruded Aluminum 2. <i>Base height:</i> 4 = 4" base height 6 = 6" base height (add \$47 per panel for this option) 3. <i>Beltway:</i> B0 = No Beltway B1 = Beltway 1 side Applicable finishes are listed on page 5 and 6.	The Reff System does not support the stacking of modules onto 42"H panels. These panels can be used to achieve transaction top height (see transaction tops page). 6" Raceway option increases panel height by 2 3/4". Product on this page can be attached to posts 42", 49", 64", and 79"H as well as panels 42", 49", 64" and 79"H. Panels on this page will not attach to panels made before April 1997 without an attachment kit from page 117. Remember to specify Beltway paint finish when applicable. 79"H hookstrip reveal strips are ordered separately from page 117 at no charge. Fabric and techwood covers of 60", 66" and 72" wide panels are two pieces, split vertically.

# Monolithic panels 42" H

*fabric one side, conventional veneer other side*

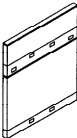
description	w	h	pattern no.	grade						
				10	15	20	30	35	40	45
Monolithic, fabric one side Regular acoustics 	18"	42"	<b>R3B0PF242 18-( )</b> ( )	\$550.	\$559.	\$581.	\$626.	\$661.	\$700.	\$728.
	20"	42"	<b>R3B0PF242 20-( )</b> ( )	550.	559.	581.	626.	661.	700.	728.
	24"	42"	<b>R3B0PF242 24-( )</b> ( )	559.	568.	590.	635.	670.	709.	737.
	30"	42"	<b>R3B0PF242 30-( )</b> ( )	671.	680.	702.	747.	782.	821.	849.
	36"	42"	<b>R3B0PF242 36-( )</b> ( )	725.	734.	756.	801.	836.	875.	903.
	42"	42"	<b>R3B0PF242 42-( )</b> ( )	817.	826.	848.	893.	928.	967.	995.
	48"	42"	<b>R3B0PF242 48-( )</b> ( )	890.	899.	921.	966.	1,001.	1,040.	1,068.
	60"	42"	<b>R3B0PF242 60-( )</b> (*)	961.	984.	1,029.	1,118.	1,181.	1,267.	1,318.
	66"	42"	<b>R3B0PF242 66-( )</b> (*)	1,001.	1,024.	1,069.	1,158.	1,221.	1,307.	1,358.
	72"	42"	<b>R3B0PF242 72-( )</b> (*)	1,034.	1,057.	1,102.	1,191.	1,254.	1,340.	1,391.
Monolithic, fabric one side Beltway one side (fabric side) 	18"	42"	<b>R3B1PF242 18-( )</b> ( )	1,088.	1,101.	1,130.	1,189.	1,221.	1,270.	1,305.
	20"	42"	<b>R3B1PF242 20-( )</b> ( )	1,088.	1,101.	1,130.	1,189.	1,221.	1,270.	1,305.
	24"	42"	<b>R3B1PF242 24-( )</b> ( )	1,111.	1,124.	1,153.	1,212.	1,244.	1,293.	1,328.
	30"	42"	<b>R3B1PF242 30-( )</b> ( )	1,200.	1,213.	1,242.	1,301.	1,333.	1,382.	1,417.
	36"	42"	<b>R3B1PF242 36-( )</b> ( )	1,395.	1,408.	1,437.	1,496.	1,528.	1,577.	1,612.
	42"	42"	<b>R3B1PF242 42-( )</b> ( )	1,432.	1,445.	1,474.	1,533.	1,565.	1,614.	1,649.
	48"	42"	<b>R3B1PF242 48-( )</b> ( )	1,608.	1,621.	1,650.	1,709.	1,741.	1,790.	1,825.

Order Code	Specification Information	Application Notes
Example: <b>R3B0PF24218-A4K</b>	<i>To order please specify pattern number including:</i>	<i>1. Top trim profile:</i>
<b>R3</b> Reff Generation 3	1. Top trim profile	A = Flat
<b>B0</b> No Beltway	2. Base height	B = Square
<b>P</b> Monolithic panel	3. Knockout option	C = Bullnose
<b>F2</b> Fabric one side, V2 other	(K = with knockouts, N = without knockouts)	E = Extruded Aluminum
<b>42</b> 42" high	4. Panel side 1 finish(s) inside	<i>2. Base height:</i>
<b>18</b> 18" wide	For panel with Beltway option specify:	4 = 4" base height
<b>A</b> Flat style top trim profile	Side 1- Below Beltway	6 = 6" base height (add \$47 per panel for this option)
<b>4</b> 4" base height	Side 2- Above Beltway	<i>3. Beltway:</i>
<b>K</b> Include knockouts in base	5. Panel side 2 finish(s) outside	B0 = No Beltway
<b>W281</b> Fabric - Side 1	6. Top trim finish	B1 = Beltway 1 side
<b>V316</b> Maple surface - side 2	i) Top trim profile A, B or C options:	Applicable finishes are listed on page 5 and 6.
<b>V316</b> Maple (top trim finish)	V1, V2, V3, P1, P2, P3 finishes	
<b>111</b> Jet Black (base finish)	ii) Top trim profile E options:	
<b>M</b> Optional milled frame	AA-anodized aluminum or P1, P2, P3 finish listed on page 5 excluding silver	
	7. Base finish - (only for panels with Beltway option)	
	8. Beltway finish	
	9. <i>Optional non-beltway panels:</i> specify (M) for panel frame to be milled for ported components, \$14 list upcharge applicable	

The Reff System does not support the stacking of modules onto 42"H panels. These panels can be used to achieve transaction top height (see transaction tops page).

6" Raceway option increases panel height by 2 3/4".

Product on this page can be attached to posts 42", 49", 64", and 79"H as well as panels 42", 49", 64" and 79"H. Panels on this page will not attach to panels made before April 1997 without an attachment kit from page 117.

Remember to specify Beltway paint finish when applicable.

79"H hookstrip reveal strips are ordered separately from page 117 at no charge.

Fabric and veneer covers of 60", 66" and 72" wide panels are two pieces, split vertically.

# Monolithic panels 42" H

*fabric one side, exotic veneer other side*

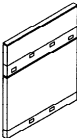
description	w	h	pattern no.	grade						
				10	15	20	30	35	40	45
Monolithic, fabric one side Regular acoustics 	18"	42"	<b>R3B0PF342 18-</b> ( ) ( )	\$728.	\$737.	\$759.	\$804.	\$839.	\$878.	\$906.
	20"	42"	<b>R3B0PF342 20-</b> ( ) ( )	728.	737.	759.	804.	839.	878.	906.
	24"	42"	<b>R3B0PF342 24-</b> ( ) ( )	739.	748.	770.	815.	850.	889.	917.
	30"	42"	<b>R3B0PF342 30-</b> ( ) ( )	890.	899.	921.	966.	1,001.	1,040.	1,068.
	36"	42"	<b>R3B0PF342 36-</b> ( ) ( )	963.	972.	994.	1,039.	1,074.	1,113.	1,141.
	42"	42"	<b>R3B0PF342 42-</b> ( ) ( )	1,087.	1,096.	1,118.	1,163.	1,198.	1,237.	1,265.
	48"	42"	<b>R3B0PF342 48-</b> ( ) ( )	1,186.	1,195.	1,217.	1,262.	1,297.	1,336.	1,364.
	60"	42"	<b>R3B0PF342 60-</b> ( ) (*)	1,268.	1,291.	1,336.	1,425.	1,488.	1,574.	1,625.
	66"	42"	<b>R3B0PF342 66-</b> ( ) (*)	1,321.	1,344.	1,389.	1,478.	1,541.	1,627.	1,678.
	72"	42"	<b>R3B0PF342 72-</b> ( ) (*)	1,367.	1,390.	1,435.	1,524.	1,587.	1,673.	1,724.
Monolithic, fabric one side Beltway fabric side 	18"	42"	<b>R3B1PF342 18-</b> ( ) ( )	1,453.	1,466.	1,495.	1,554.	1,586.	1,635.	1,670.
	20"	42"	<b>R3B1PF342 20-</b> ( ) ( )	1,453.	1,466.	1,495.	1,554.	1,586.	1,635.	1,670.
	24"	42"	<b>R3B1PF342 24-</b> ( ) ( )	1,484.	1,497.	1,526.	1,585.	1,617.	1,666.	1,701.
	30"	42"	<b>R3B1PF342 30-</b> ( ) ( )	1,604.	1,617.	1,646.	1,706.	1,737.	1,786.	1,821.
	36"	42"	<b>R3B1PF342 36-</b> ( ) ( )	1,869.	1,882.	1,911.	1,970.	2,002.	2,051.	2,086.
	42"	42"	<b>R3B1PF342 42-</b> ( ) ( )	1,918.	1,931.	1,960.	2,019.	2,051.	2,100.	2,135.
	48"	42"	<b>R3B1PF342 48-</b> ( ) ( )	2,157.	2,170.	2,199.	2,258.	2,290.	2,339.	2,374.

Order Code	Specification Information	Application Notes
Example: <b>R3B0PF34218-A4K</b> <b>R3</b> Reff Generation 3 <b>B0</b> No Beltway, B1=Beltway, one side <b>P</b> Monolithic panel <b>F3</b> Fabric one side, V3 other <b>42</b> 42" high <b>18</b> 18" wide <b>A</b> Flat style top trim profile <b>4</b> 4" base height <b>K</b> Include knockouts in base <b>W281</b> Fabric - Side 1 <b>V512</b> Figured Anigre surface - side 2 <b>V512</b> Figured Anigre (top trim finish) <b>111</b> Jet Black (base finish) <b>M</b> Optional milled frame	To order please specify pattern number including: 1. Top trim profile 2. Base height 3. Knockout option (K = with knockouts, N = without knockouts) 4. Panel side 1 finish(s) inside For panel with Beltway option specify: Side 1=Below Beltway Side 2=Above Beltway 5. Panel side 2 finish(s) outside 6. Top trim finish i) Top trim profile A,B or C options: V1, V2, V3, P1, P2, P3 finishes ii) Top trim profile E options: AA-anodized aluminum or P1, P2, P3 finish listed on page 5 excluding silver 7. Base finish 8. Beltway finish (only for panels with Beltway option) 9. <i>Optional non-beltway panels:</i> specify (M) for panel frame to be milled for ported components, \$14 list upcharge applicable	1. <i>Top trim profile:</i> A = Flat B = Square C = Bullnose E = Extruded Aluminum 2. <i>Base height:</i> 4 = 4" base height 6 = 6" base height (add \$47 per panel for this option) 3. <i>Beltway:</i> B0 = No Beltway B1 = Beltway 1 side Applicable finishes are listed on page 5 and 6. The Reff System does not support the stacking of modules onto 42"H panels. These panels can be used to achieve transaction top height (see transaction tops page). 6" Raceway option increases panel height by 2 3/4". Product on this page can be attached to posts 42", 49", 64", and 79"H as well as panels 42", 49", 64" and 79"H. Panels on this page will not attach to panels made before April 1997 without an attachment kit from page 117. Remember to specify Beltway paint finish when applicable. 79"H hookstrip reveal strips are ordered separately from page 117 at no charge. Fabric and veneer covers of 60", 66" and 72" wide panels are two pieces, split vertically.

# Monolithic panels 42" H

## Laminate/Laminate

Reff Profiles

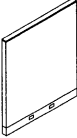
description	w	h	pattern no.	L
Monolithic, laminate both sides with raceway both sides 	18"	42"	<b>R3B0PLL4218</b> ( ) ( )	\$612.
	20"	42"	<b>R3B0PLL4220</b> ( ) ( )	612.
	24"	42"	<b>R3B0PLL4224</b> ( ) ( )	667.
	30"	42"	<b>R3B0PLL4230</b> ( ) ( )	747.
	36"	42"	<b>R3B0PLL4236</b> ( ) ( )	807.
	42"	42"	<b>R3B0PLL4242</b> ( ) ( )	887.
	48"	42"	<b>R3B0PLL4248</b> ( ) ( )	993.
	60"	42"	<b>R3B0PLL4260</b> ( ) ( )*	1,073.
	66"	42"	<b>R3B0PLL4266</b> ( ) ( )*	1,106.
72"	42"	<b>R3B0PLL4272</b> ( ) ( )*	1,138.	

Order Code	Specification Information	Application Notes
Example: <b>R3B0PLL4218-A4K</b>	<i>To order please specify pattern number including:</i>	<i>1. Top trim profile:</i>
<b>R3</b> Reff Generation 3	1. Top trim profile	A = Flat
<b>B0</b> No Beltway	2. Base height	B = Square
<b>P</b> Monolithic panel	3. Knockout option	C = Bullnose
<b>LL</b> Laminate both sides	(K = with knockouts, N = without knockouts)	E = Extruded Aluminum
<b>42</b> 42" high	4. Panel side 1 inside	<i>2. Base height:</i>
<b>18</b> 18" wide	5. Panel side 2 outside	4 = 4" base height
<b>A</b> Flat style top trim profile	6. Top trim finish	<i>3. Beltway:</i>
<b>4</b> 4" base height	i) Top trim profile A,B or C options:	B0 = No Beltway
<b>K</b> Include knockouts in base	V1, V2, V3, P1, P2, P3 finishes	B1 = Beltway 1 side
<b>118</b> Laminate - side 1	ii) Top trim profile E options:	Applicable finishes are listed on page 5 and 6.
<b>118</b> Laminate - side 2	AA-anodized aluminum or P1, P2, P3 finish listed on page 5 excluding silver	Product on this page will accept wood grain laminate where laminate is currently an option.
<b>V512</b> Figured Anigre (top trim finish)	7. Base finish	Panel product is subject to a 10% upcharge on the base panel price. Refer to panel product upcharge table.
<b>111</b> Jet Black (base finish)	8. <i>Optional non-beltway panels:</i> specify (M) for panel frame to be milled for ported components, \$14 list upcharge applicable	Product on this page will accept wood grain laminate where laminate is currently an option. Panel product is subject to a 10% upcharge on the base panel price. Refer to panel product upcharge table.
<b>M</b> Optional milled frame		Product on this page will accept wood grain laminate where laminate is currently an option. Panel product is subject to a 10% upcharge on the base panel price. Refer to panel product upcharge table.

The Reff System does not support the stacking of modules onto 42"H panels. These panels can be used to achieve transaction top height (see transaction tops page).

6" Raceway option increases panel height by 2<sup>3</sup>/<sub>4</sub>".

Product on this page can be attached to posts 42", 49", 64", and 79"H as well as panels 42", 49", 64" and 79"H. Panels on this page will not attach to panels made before April 1997 without an attachment kit from page 117.

Remember to specify Beltway paint finish when applicable.

79"H hookstrip reveal strips are ordered separately from page 117 at no charge.

Fabric and veneer covers of 60", 66" and 72" wide panels are two pieces, split vertically.

# Monolithic panels 49" H fabric both sides

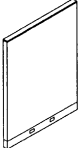
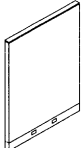
description	w	h	pattern no.	grade							
				10	15	20	30	35	40	45	
Monolithic, fabric both sides	18"	49"	<b>R3B0PFF49 18-()</b> ( )	\$600.	\$628.	\$678.	\$786.	\$856.	\$950.	\$1,010.	
Regular acoustics	20"	49"	<b>R3B0PFF49 20-()</b> ( )	600.	628.	678.	786.	856.	950.	1,010.	
	24"	49"	<b>R3B0PFF49 24-()</b> ( )	640.	668.	718.	826.	896.	990.	1,050.	
	30"	49"	<b>R3B0PFF49 30-()</b> ( )	695.	723.	773.	881.	951.	1,045.	1,105.	
	36"	49"	<b>R3B0PFF49 36-()</b> ( )	727.	755.	805.	913.	983.	1,077.	1,137.	
	42"	49"	<b>R3B0PFF49 42-()</b> ( )	784.	812.	862.	970.	1,040.	1,134.	1,194.	
	48"	49"	<b>R3B0PFF49 48-()</b> ( )	861.	889.	938.	1,046.	1,117.	1,211.	1,271.	
	60"	49"	<b>R3B0PFF49 60-()</b> ( )*	996.	1,040.	1,142.	1,356.	1,500.	1,690.	1,806.	
	66"	49"	<b>R3B0PFF49 66-()</b> ( )*	1,028.	1,072.	1,174.	1,388.	1,532.	1,722.	1,838.	
	72"	49"	<b>R3B0PFF49 72-()</b> ( )*	1,058.	1,102.	1,204.	1,418.	1,562.	1,752.	1,868.	
	Monolithic, fabric both sides	18"	49"	<b>R3B0PAA49 18-()</b> ( )	654.	682.	732.	840.	911.	1,004.	1,064.
	High acoustics	20"	49"	<b>R3B0PAA49 20-()</b> ( )	654.	682.	732.	840.	911.	1,004.	1,064.
	24"	49"	<b>R3B0PAA49 24-()</b> ( )	700.	728.	778.	886.	957.	1,050.	1,110.	
	30"	49"	<b>R3B0PAA49 30-()</b> ( )	759.	787.	837.	945.	1,015.	1,109.	1,169.	
	36"	49"	<b>R3B0PAA49 36-()</b> ( )	796.	824.	874.	982.	1,052.	1,146.	1,206.	
	42"	49"	<b>R3B0PAA49 42-()</b> ( )	860.	888.	938.	1,046.	1,116.	1,210.	1,270.	
	48"	49"	<b>R3B0PAA49 48-()</b> ( )	945.	973.	1,023.	1,131.	1,201.	1,295.	1,355.	
	60"	49"	<b>R3B0PAA49 60-()</b> ( )*	1,082.	1,126.	1,228.	1,442.	1,586.	1,776.	1,892.	
	66"	49"	<b>R3B0PAA49 66-()</b> ( )*	1,120.	1,164.	1,266.	1,480.	1,624.	1,814.	1,930.	
	72"	49"	<b>R3B0PAA49 72-()</b> ( )*	1,157.	1,201.	1,303.	1,517.	1,661.	1,851.	1,967.	

Order Code	Specification Information	Application Notes
Example: <b>R3B0PFF4918-A4K</b>	<i>To order please specify pattern number including:</i>	
<b>R3</b> Reff Generation 3	1. Top trim profile	1. <i>Top trim profile:</i> A = Flat B = Square C = Bullnose E = Extruded Aluminum
<b>B0</b> No Beltway	2. Base height	2. <i>Base height:</i> 4 = 4" base height 6 = 6" base height (add \$47 per panel for this option)
<b>P</b> Monolithic panel	3. Knockout option (K = with knockouts, N = without knockouts)	6" Raceway option increases panel height by 2 3/4".
<b>FF</b> Fabric on both sides	4. Panel side 1 finish(s) inside	Applicable finishes are listed on page 5 and 6.
<b>49</b> 49" high	5. Panel side 2 finish(s) outside	*Fabric inserts of these panels are two pieces, split vertically.
<b>18</b> 18" wide	6. Top trim finish i) Top trim profile A,B or C options: V1, V2, V3, P1, P2, P3 finishes ii) Top trim profile E options: AA-anodized aluminum or P1, P2, P3 finish listed on page 5 excluding silver	The panels on this page will accept stacking modules to increase their height on 18" to 48"W panels only. The 60" to 72"W panels will not accept stacking modules on top of themselves.
<b>A</b> Flat style top trim profile	7. Base finish	Product on this page can be attached to posts 49", 64", and 79"H as well as panels 42", 49", 64" and 79"H. Panels on this page will not attach to panels made before April 1997 without an attachment kit from page 117.
<b>4</b> 4" base height	8. <i>Optional non-beltway panels:</i> specify (M) for panel frame to be milled for ported components, \$14 list upcharge applicable	Remember to specify Beltway paint finish when applicable.
<b>K</b> Include knockouts in base		*These panel widths do not accept stacking modules.
<b>W281</b> Fabric - Side 1		79"H hookstrip reveal strips are ordered separately from page 117 at no charge.
<b>W281</b> Fabric - Side 2		
<b>V316</b> Maple (top trim finish)		
<b>111</b> Jet Black (base finish)		
<b>M</b> Optional milled frame		

# Monolithic panels 49" H with Beltway

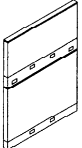
description	w	h	pattern no.	grade						
				10	15	20	30	35	40	45
Monolithic, fabric both sides	18"	49"	<b>R3B2PFF49 18-( )()</b>	\$1,086.	\$1,120.	\$1,190.	\$1,304.	\$1,386.	\$1,504.	\$1,578.
Beltway two sides, regular acoustics	20"	49"	<b>R3B2PFF49 20-( )()</b>	1,086.	1,120.	1,190.	1,304.	1,386.	1,504.	1,578.
	24"	49"	<b>R3B2PFF49 24-( )()</b>	1,109.	1,143.	1,213.	1,327.	1,409.	1,527.	1,601.
	30"	49"	<b>R3B2PFF49 30-( )()</b>	1,165.	1,199.	1,269.	1,383.	1,465.	1,583.	1,657.
	36"	49"	<b>R3B2PFF49 36-( )()</b>	1,375.	1,409.	1,479.	1,593.	1,675.	1,793.	1,867.
	42"	49"	<b>R3B2PFF49 42-( )()</b>	1,480.	1,514.	1,584.	1,698.	1,780.	1,898.	1,972.
	48"	49"	<b>R3B2PFF49 48-( )()</b>	1,532.	1,566.	1,636.	1,750.	1,832.	1,950.	2,024.
	Monolithic, fabric both sides	18"	49"	<b>R3B1PFF49 18-( )()</b>	1,066.	1,097.	1,157.	1,268.	1,344.	1,450.
Beltway one side	20"	49"	<b>R3B1PFF49 20-( )()</b>	1,066.	1,097.	1,157.	1,268.	1,344.	1,450.	1,517.
	24"	49"	<b>R3B1PFF49 24-( )()</b>	1,087.	1,118.	1,178.	1,289.	1,365.	1,471.	1,538.
	30"	49"	<b>R3B1PFF49 30-( )()</b>	1,140.	1,171.	1,231.	1,342.	1,418.	1,524.	1,591.
	36"	49"	<b>R3B1PFF49 36-( )()</b>	1,348.	1,379.	1,439.	1,550.	1,626.	1,732.	1,799.
	42"	49"	<b>R3B1PFF49 42-( )()</b>	1,448.	1,479.	1,539.	1,650.	1,726.	1,832.	1,899.
	48"	49"	<b>R3B1PFF49 48-( )()</b>	1,499.	1,530.	1,590.	1,701.	1,777.	1,883.	1,950.

Order Code	Specification Information	Application Notes
Example: <b>R3B2PFF4918-A4K</b>	<i>To order please specify pattern number including:</i>	
<b>R3</b> Reff Generation 3	1. Top trim profile	1. <i>Top trim profile:</i> A = Flat B = Square C = Bullnose E = Extruded Aluminum
<b>B2</b> Beltway, both sides	2. Base height	
<b>P</b> Monolithic panel	3. Knockout option (K = with knockouts, N = without knockouts)	2. <i>Base height:</i> 4 = 4" base height 6 = 6" base height (add \$47 per panel for this option)
<b>FF</b> Fabric on both sides	4. Panel 1 finish(s) Below Belt	3. <i>Beltway:</i> B0 = No Beltway B1 = Beltway 1 side
<b>49</b> 49" high	5. Panel 2 finish(s) Above Belt	6" Raceway option increases panel height by 2 <sup>3</sup> / <sub>4</sub> ".
<b>18</b> 18" wide	6. Panel 2 finish(s) Below Belt	Applicable finishes are listed on page 5 and 6.
<b>A</b> Flat style top trim profile	7. Panel 2 finish(s) Above Belt	*Fabric inserts of these panels are two pieces, split vertically.
<b>4</b> 4" base height	8. Top trim finish i) Top trim profile A, B or C options: V1, V2, V3, P1, P2, P3 finishes ii) Top trim profile E options: AA-anodized aluminum or P1, P2, P3 finish listed on page 5 excluding silver	
<b>K</b> Include knockouts in base	9. Base finish	
<b>W281</b> Side 1 - Below Belt	10. Beltway finish	
<b>W281</b> Side 1 - Above Belt		
<b>W281</b> Side 2 - Below Belt		
<b>W281</b> Side 2 - Above Belt		
<b>V316</b> Maple (top trim finish)		
<b>111</b> Jet Black (base finish)		
<b>M</b> Optional milled frame		
<b>111</b> Beltway finish		



# Monolithic panels 49" H

*fabric one side, laminate other side*

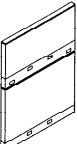
description	w	h	pattern no.	grade						
				10	15	20	30	35	40	45
Monolithic, fabric one side Regular acoustics 	18"	49"	<b>R3B0PFL49 18-( ) ( )</b>	\$510.	\$524.	\$545.	\$593.	\$624.	\$666.	\$692.
	20"	49"	<b>R3B0PFL49 20-( ) ( )</b>	510.	524.	545.	593.	624.	666.	692.
	24"	49"	<b>R3B0PFL49 24-( ) ( )</b>	558.	572.	593.	641.	672.	714.	740.
	30"	49"	<b>R3B0PFL49 30-( ) ( )</b>	632.	646.	667.	715.	746.	788.	814.
	36"	49"	<b>R3B0PFL49 36-( ) ( )</b>	682.	696.	717.	765.	796.	838.	864.
	42"	49"	<b>R3B0PFL49 42-( ) ( )</b>	753.	767.	788.	836.	867.	909.	935.
	48"	49"	<b>R3B0PFL49 48-( ) ( )</b>	847.	861.	882.	930.	961.	1,003.	1,029.
	60"	49"	<b>R3B0PFL49 60-( ) ( ) *</b>	923.	943.	989.	1,082.	1,146.	1,231.	1,281.
	66"	49"	<b>R3B0PFL49 66-( ) ( ) *</b>	949.	969.	1,015.	1,108.	1,171.	1,257.	1,307.
	72"	49"	<b>R3B0PFL49 72-( ) ( ) *</b>	982.	1,002.	1,048.	1,141.	1,205.	1,290.	1,340.
Monolithic, fabric one side Beltway one side (fabric side) 	18"	49"	<b>R3B1PFL49 18-( ) ( )</b>	923.	938.	967.	1,020.	1,055.	1,106.	1,141.
	20"	49"	<b>R3B1PFL49 20-( ) ( )</b>	923.	938.	967.	1,020.	1,055.	1,106.	1,141.
	24"	49"	<b>R3B1PFL49 24-( ) ( )</b>	960.	975.	1,004.	1,057.	1,092.	1,143.	1,178.
	30"	49"	<b>R3B1PFL49 30-( ) ( )</b>	1,032.	1,047.	1,076.	1,129.	1,164.	1,215.	1,250.
	36"	49"	<b>R3B1PFL49 36-( ) ( )</b>	1,240.	1,255.	1,284.	1,337.	1,372.	1,423.	1,458.
	42"	49"	<b>R3B1PFL49 42-( ) ( )</b>	1,354.	1,369.	1,398.	1,451.	1,486.	1,537.	1,572.
	48"	49"	<b>R3B1PFL49 48-( ) ( )</b>	1,427.	1,442.	1,471.	1,524.	1,559.	1,610.	1,645.

Order Code	Specification Information	Application Notes
Example: <b>R3B0PFL4918-A4K</b> <b>R3</b> Reff Generation 3 <b>B0</b> No Beltway <b>P</b> Monolithic panel <b>FL</b> Fabric one side, laminate other <b>49</b> 49" high <b>18</b> 18" wide <b>A</b> Flat style top trim profile <b>4</b> 4" base height <b>K</b> Include knockouts in base <b>W281</b> Fabric - Side 1 <b>114</b> Folkstone grey - side 2 <b>V316</b> Maple (top trim finish) <b>111</b> Jet Black (base finish) <b>M</b> Optional milled frame	To order please specify pattern number including: 1. Top trim profile 2. Base height 3. Knockout option (K = with knockouts, N = without knockouts) 4. Panel side 1 finish(s) inside For panel with Beltway option, please specify, Side 1 - Below Beltway Side 1 - Above Beltway 5. Panel side 2 finish(s) outside 6. Top trim finish i) Top trim profile A, B or C options: V1, V2, V3, P1, P2, P3 finishes ii) Top trim profile E options: AA-anodized aluminum or P1, P2, P3 finish listed on page 5 excluding silver 7. Base finish 8. Beltway finish - only for panels with beltway option 9. <i>Optional non-beltway panels:</i> specify (M) for panel frame to be milled for ported components, \$14 list upcharge applicable	1. <i>Top trim profile:</i> A = Flat B = Square C = Bullnose E = Extruded Aluminum 2. <i>Base height:</i> 4 = 4" base height 6 = 6" base height (add \$47 per panel for this option) 3. <i>Beltway:</i> B0 = No Beltway B1 = Beltway 1 side 6" Raceway option increases panel height by 2 3/4". Applicable finishes are listed on page 5 and 6. Product on this page will accept wood grain laminate where laminate is currently an option. Panel product is subject to a 10% upcharge on the base panel price. Refer to panel product upcharge table.

The panels on this page will accept stacking modules to increase their height on 18" to 48"W panels only. The 60" to 72"W panels will not accept stacking modules on top of themselves. Fabric and laminate covers of 60", 66" and 72" wide panels are two pieces, split vertically.

Product on this page can be attached to posts 49", 64", and 79"H as well as panels 42", 49", 64" and 79"H. Panels on this page will not attach to panels made before April 1997 without an attachment kit from page 117.

Remember to specify Beltway paint finish when applicable.

\*These panel widths do not accept stacking modules.

79"H hookstrip reveal strips are ordered separately from page 117 at no charge.

# Monolithic panels 49" H

*fabric one side, techwood other side*

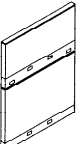
description	w	h	pattern no.	grade						
				10	15	20	30	35	40	45
Monolithic, fabric one side Regular acoustics 	18"	49"	<b>R3B0PF149 18-( )</b> ( )	\$600.	\$616.	\$640.	\$695.	\$733.	\$778.	\$811.
	20"	49"	<b>R3B0PF149 20-( )</b> ( )	600.	616.	640.	695.	733.	778.	811.
	24"	49"	<b>R3B0PF149 24-( )</b> ( )	656.	672.	696.	751.	789.	834.	867.
	30"	49"	<b>R3B0PF149 30-( )</b> ( )	747.	763.	787.	842.	880.	925.	958.
	36"	49"	<b>R3B0PF149 36-( )</b> ( )	800.	816.	840.	895.	933.	978.	1,011.
	42"	49"	<b>R3B0PF149 42-( )</b> ( )	886.	902.	926.	981.	1,019.	1,064.	1,097.
	48"	49"	<b>R3B0PF149 48-( )</b> ( )	996.	1,012.	1,036.	1,091.	1,129.	1,174.	1,207.
	60"	49"	<b>R3B0PF149 60-( )</b> ( ) *	1,084.	1,108.	1,162.	1,269.	1,343.	1,438.	1,498.
	66"	49"	<b>R3B0PF149 66-( )</b> ( ) *	1,115.	1,139.	1,193.	1,300.	1,374.	1,469.	1,529.
	72"	49"	<b>R3B0PF149 72-( )</b> ( ) *	1,153.	1,177.	1,231.	1,338.	1,412.	1,507.	1,567.
Monolithic, fabric one side Beltway one side (fabric side) 	18"	49"	<b>R3B1PF149 18-( )</b> ( )	1,089.	1,105.	1,142.	1,200.	1,240.	1,300.	1,339.
	20"	49"	<b>R3B1PF149 20-( )</b> ( )	1,089.	1,105.	1,142.	1,200.	1,240.	1,300.	1,339.
	24"	49"	<b>R3B1PF149 24-( )</b> ( )	1,128.	1,144.	1,181.	1,239.	1,279.	1,339.	1,378.
	30"	49"	<b>R3B1PF149 30-( )</b> ( )	1,212.	1,228.	1,265.	1,323.	1,363.	1,423.	1,462.
	36"	49"	<b>R3B1PF149 36-( )</b> ( )	1,457.	1,473.	1,510.	1,568.	1,608.	1,668.	1,707.
	42"	49"	<b>R3B1PF149 42-( )</b> ( )	1,594.	1,610.	1,647.	1,705.	1,745.	1,805.	1,844.
	48"	49"	<b>R3B1PF149 48-( )</b> ( )	1,676.	1,692.	1,729.	1,787.	1,827.	1,887.	1,926.

Order Code	Specification Information	Application Notes
Example: <b>R3B0PF14918-A4K</b>	<i>To order please specify pattern number including:</i>	<i>1. Top trim profile:</i>
<b>R3</b> Reff Generation 3	1. Top rim profile	A = Flat
<b>B0</b> No Beltway	2. Base height	B = Square
<b>P</b> Monolithic panel	3. Knockout option	C = Bullnose
<b>F1</b> Fabric one side, V1 other	(K = with knockouts, N = without knockouts)	E = Extruded Aluminum
<b>49</b> 49" high	4. Panel side 1 finish(s) inside	<i>2. Base height:</i>
<b>18</b> 18" wide	For panel with Beltway, please specify:	4 = 4" base height
<b>A</b> Flat style top trim profile	Side 1 - Below Belt	6 = 6" base height (add \$47 per panel for this option)
<b>4</b> 4" base height	Side 1 - Above Belt	<i>3. Beltway:</i>
<b>K</b> Include knockouts in base	5. Panel side 2 finish(s) outside	B0 = No Beltway
<b>W281</b> Fabric - Side 1	6. Top trim finish	B1 = Beltway 1 side
<b>Y328</b> Mahogany - side 2	i) Top trim profile A, B or C options:	<i>6" Raceway option increases panel height by 2 3/4".</i>
<b>V316</b> Maple (top trim finish)	V1, V2, V3, P1, P2, P3 finishes	Applicable finishes are listed on page 5 and 6.
<b>111</b> Jet Black (base finish)	ii) Top trim profile E options:	
<b>M</b> Optional milled frame	AA-anodized aluminum or P1, P2, P3 finish listed on page 5 excluding silver	
	7. Base finish	
	8. Beltway finish - only for panels with Beltway	
	9. <i>Optional non-beltway panels:</i> specify (M) for panel frame to be milled for ported components, \$14 list upcharge applicable	

The panels on this page will accept stacking modules to increase their height on 18" to 48"W panels only. The 60" to 72"W panels will not accept stacking modules on top of themselves. Fabric and techwood covers of 60", 66" and 72" wide panels are two pieces, split vertically.

Product on this page can be attached to posts 49", 64", and 79"H as well as panels 42", 49", 64" and 79"H. Panels on this page will not attach to panels made before April 1997 without an attachment kit from page 117.

Remember to specify Beltway paint finish when applicable.

\*These panel widths do not accept stacking modules.

79"H hookstrip reveal strips are ordered separately from page 117 at no charge.

# Monolithic panels 49" H

*fabric one side, conventional veneer other side*

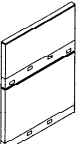
description	w	h	pattern no.	grade						
				10	15	20	30	35	40	45
Monolithic, fabric one side Regular acoustics 	18"	49"	<b>R3B0PF249 18-( ) ( )</b>	\$610.	\$626.	\$650.	\$705.	\$743.	\$788.	\$821.
	20"	49"	<b>R3B0PF249 20-( ) ( )</b>	610.	626.	650.	705.	743.	788.	821.
	24"	49"	<b>R3B0PF249 24-( ) ( )</b>	668.	684.	708.	763.	801.	846.	879.
	30"	49"	<b>R3B0PF249 30-( ) ( )</b>	758.	774.	798.	853.	891.	936.	969.
	36"	49"	<b>R3B0PF249 36-( ) ( )</b>	815.	831.	855.	910.	948.	993.	1,026.
	42"	49"	<b>R3B0PF249 42-( ) ( )</b>	901.	917.	941.	996.	1,034.	1,079.	1,112.
	48"	49"	<b>R3B0PF249 48-( ) ( )</b>	1,017.	1,033.	1,057.	1,112.	1,150.	1,195.	1,228.
	60"	49"	<b>R3B0PF249 60-( ) ( ) *</b>	1,103.	1,127.	1,181.	1,288.	1,362.	1,457.	1,517.
	66"	49"	<b>R3B0PF249 66-( ) ( ) *</b>	1,139.	1,163.	1,217.	1,324.	1,398.	1,493.	1,553.
	72"	49"	<b>R3B0PF249 72-( ) ( ) *</b>	1,174.	1,198.	1,252.	1,359.	1,433.	1,528.	1,588.
Monolithic, fabric one side Beltway one side (fabric side) 	18"	49"	<b>R3B1PF249 18-( ) ( )</b>	1,108.	1,124.	1,161.	1,219.	1,259.	1,319.	1,358.
	20"	49"	<b>R3B1PF249 20-( ) ( )</b>	1,108.	1,124.	1,161.	1,219.	1,259.	1,319.	1,358.
	24"	49"	<b>R3B1PF249 24-( ) ( )</b>	1,148.	1,164.	1,201.	1,259.	1,299.	1,359.	1,398.
	30"	49"	<b>R3B1PF249 30-( ) ( )</b>	1,238.	1,254.	1,291.	1,349.	1,389.	1,449.	1,488.
	36"	49"	<b>R3B1PF249 36-( ) ( )</b>	1,487.	1,503.	1,540.	1,598.	1,638.	1,698.	1,737.
	42"	49"	<b>R3B1PF249 42-( ) ( )</b>	1,621.	1,637.	1,674.	1,732.	1,772.	1,832.	1,871.
	48"	49"	<b>R3B1PF249 48-( ) ( )</b>	1,704.	1,720.	1,757.	1,815.	1,855.	1,915.	1,954.

Order Code	Specification Information	Application Notes
Example: <b>R3B0PF24918-A4K</b> <b>R3</b> Reff Generation 3 <b>B0</b> No Beltway <b>P</b> Monolithic panel <b>F2</b> Fabric one side, V2 other <b>49</b> 49" high <b>18</b> 18" wide <b>A</b> Flat style top trim option <b>4</b> 4" base height <b>K</b> Include knockouts in base <b>W281</b> Fabric - Side 1 <b>V316</b> Maple surface - side 2 <b>V316</b> Maple (top trim finish) <b>111</b> Jet Black (base finish) <b>M</b> Optional milled frame	To order please specify pattern number including: 1. Top trim profile 2. Base height 3. Knockout option (K = with knockouts, N = without knockouts) 4. Panel side 1 finish(s) inside For panels with Beltway, please specify: Side 1 - Below Belt Side 1 - Above Belt 5. Panel side 2 finish(s) outside 6. Top trim finish i) Top trim profile A, B or C options: V1, V2, V3, P1, P2, P3 finishes ii) Top trim profile E options: AA-anodized aluminum or P1, P2, P3 finish listed on page 5 excluding silver 7. Base finish 8. Beltway finish - only for panels with Beltway 9. <i>Optional non-beltway panels:</i> specify (M) for panel frame to be milled for ported components, \$14 list upcharge applicable	1. <i>Top trim profile:</i> A = Flat B = Square C = Bullnose E = Extruded Aluminum 2. <i>Base height:</i> 4 = 4" base height 6 = 6" base height (add \$47 per panel for this option) 3. <i>Beltway:</i> B0 = No Beltway B1 = Beltway 1 side 6" Raceway option increases panel height by 2 3/4". Applicable finishes are listed on page 5 and 6. The panels on this page will accept stacking modules to increase their height on 18" to 48"W panels only. The 60" to 72"W panels will not accept stacking modules on top of themselves. Fabric and veneer covers of 60", 66" and 72" wide panels are two pieces, split vertically Product on this page can be attached to posts 49", 64", and 79"H as well as panels 42", 49", 64" and 79"H. Panels on this page will not attach to panels made before April 1997 without an attachment kit from page 117. Remember to specify Beltway paint finish when applicable. *These panel widths do not accept stacking modules. 79"H hookstrip reveal strips are ordered separately from page 117 at no charge.

# Monolithic panels 49" H

*fabric one side, exotic veneer other side*

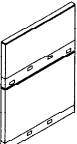
description	w	h	pattern no.	grade						
				10	15	20	30	35	40	45
Monolithic, fabric one side Regular acoustics 	18"	49"	<b>R3B0PF349 18-()</b> ( )	\$806.	\$822.	\$846.	\$901.	\$939.	\$984.	\$1,017.
	20"	49"	<b>R3B0PF349 20-()</b> ( )	806.	822.	846.	901.	939.	984.	1,017.
	24"	49"	<b>R3B0PF349 24-()</b> ( )	884.	900.	924.	979.	1,017.	1,062.	1,095.
	30"	49"	<b>R3B0PF349 30-()</b> ( )	1,006.	1,022.	1,046.	1,101.	1,139.	1,184.	1,217.
	36"	49"	<b>R3B0PF349 36-()</b> ( )	1,084.	1,100.	1,124.	1,179.	1,217.	1,262.	1,295.
	42"	49"	<b>R3B0PF349 42-()</b> ( )	1,199.	1,215.	1,239.	1,294.	1,332.	1,377.	1,410.
	48"	49"	<b>R3B0PF349 48-()</b> ( )	1,354.	1,370.	1,394.	1,449.	1,487.	1,532.	1,565.
	60"	49"	<b>R3B0PF349 60-()</b> ( )*	1,453.	1,477.	1,531.	1,638.	1,712.	1,807.	1,867.
	66"	49"	<b>R3B0PF349 66-()</b> ( )*	1,501.	1,525.	1,579.	1,686.	1,760.	1,855.	1,915.
	72"	49"	<b>R3B0PF349 72-()</b> ( )*	1,547.	1,571.	1,625.	1,732.	1,806.	1,901.	1,961.
Monolithic, fabric one side Beltway fabric side 	18"	49"	<b>R3B1PF349 18-()</b> ( )	1,476.	1,492.	1,529.	1,587.	1,627.	1,687.	1,726.
	20"	49"	<b>R3B1PF349 20-()</b> ( )	1,476.	1,492.	1,529.	1,587.	1,627.	1,687.	1,726.
	24"	49"	<b>R3B1PF349 24-()</b> ( )	1,533.	1,549.	1,586.	1,644.	1,684.	1,744.	1,783.
	30"	49"	<b>R3B1PF349 30-()</b> ( )	1,652.	1,668.	1,705.	1,763.	1,803.	1,863.	1,902.
	36"	49"	<b>R3B1PF349 36-()</b> ( )	1,990.	2,006.	2,043.	2,101.	2,141.	2,201.	2,240.
	42"	49"	<b>R3B1PF349 42-()</b> ( )	2,170.	2,186.	2,223.	2,281.	2,321.	2,381.	2,420.
	48"	49"	<b>R3B1PF349 48-()</b> ( )	2,284.	2,300.	2,337.	2,395.	2,435.	2,495.	2,534.

Order Code	Specification Information	Application Notes
Example: <b>R3B0PF34918-A4K</b>	<i>To order please specify pattern number including:</i>	
<b>R3</b> Reff Generation 3	1. Top trim profile	1. <i>Top trim profile:</i> A = Flat B = Square C = Bullnose E = Extruded Aluminum
<b>B0</b> No Beltway	2. Base height	2. <i>Base height:</i> 4 = 4" base height 6 = 6" base height (add \$47 per panel for this option)
<b>P</b> Monolithic panel	3. Knockout option (K = with knockouts, N = without knockouts)	3. <i>Beltway:</i> B0 = No Beltway B1 = Beltway 1 side
<b>F3</b> Fabric one side, V3 other	4. Panel side 1 finish(s) inside For panels with Beltway, please specify: Side 1 - Below belt Side 1 - Above belt	6" Raceway option increases panel height by 2 3/4".
<b>49</b> 49" high	5. Panel side 2 finish(s) outside	Applicable finishes are listed on page 5 and 6.
<b>18</b> 18" wide	6. Top trim finish i) Top trim profile A, B or C options: V1, V2, V3, P1, P2, P3 finishes ii) Top trim profile E options: AA-anodized aluminum or P1, P2, P3 finish listed on page 5 excluding silver	Product on this page can be attached to posts 49", 64", and 79"H as well as panels 42", 49", 64" and 79"H. Panels on this page will not attach to panels made before April 1997 without an attachment kit from page 117.
<b>A</b> Flat style top trim option	7. Base finish	Remember to specify Beltway paint finish when applicable.
<b>4</b> 4" base height	8. Beltway finish - only for panels with Beltway	*These panel widths do not accept stacking modules.
<b>K</b> Include knockouts in base	9. <i>Optional non-beltway panels:</i> specify (M) for panel frame to be milled for ported components, \$14 list upcharge applicable	79"H hookstrip reveal strips are ordered separately from page 117 at no charge.
<b>W281</b> Fabric - Side 1		
<b>V512</b> Figured Anigre surface - side 2		
<b>V512</b> Figured Anigre (top trim finish)		
<b>111</b> Jet Black (base finish)		
<b>M</b> Optional milled frame		

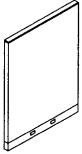

# Monolithic panels 49" H

## Laminate/Laminate

description	w	h	pattern no.	L
Monolithic, laminate both sides with raceway both sides  	18"	49"	<b>R3B0PLL4918( ) ( )</b>	\$726.
	20"	49"	<b>R3B0PLL4920( ) ( )</b>	726.
	24"	49"	<b>R3B0PLL4924( ) ( )</b>	792.
	30"	49"	<b>R3B0PLL4930( ) ( )</b>	887.
	36"	49"	<b>R3B0PLL4936( ) ( )</b>	958.
	42"	49"	<b>R3B0PLL4942( ) ( )</b>	1,053.
	48"	49"	<b>R3B0PLL4948( ) ( )</b>	1,180.
	60"	49"	<b>R3B0PLL4960( ) ( )*</b>	1,274.
	66"	49"	<b>R3B0PLL4966( ) ( )*</b>	1,312.
	72"	49"	<b>R3B0PLL4972( ) ( )*</b>	1,351.

Order Code	Specification Information	Application Notes
Example: <b>R3B0PLL4918-A4K</b> <b>R3</b> Reff Generation 3 <b>B0</b> No Beltway <b>P</b> Monolithic panel <b>LL</b> Laminate both sides <b>49</b> 49" high <b>18</b> 18" wide <b>A</b> Flat style top trim profile <b>4</b> 4" base height <b>K</b> Include knockouts in base <b>118</b> Laminate - side 1 <b>118</b> Laminate - side 2 <b>V512</b> Figured Anigre (top trim finish) <b>111</b> Jet Black (base finish) <b>M</b> Optional milled frame	To order please specify pattern number including: 1. Top trim profile 2. Base height 3. Knockout option (K = with knockouts, N = without knockouts) 4. Panel side 1 inside 5. Panel side 2 outside 6. Top trim finish i) Top trim profile A, B or C options: V1, V2, V3, P1, P2, P3 finishes ii) Top trim profile E options: AA-anodized aluminum or P1, P2, P3 finish listed on page 5 excluding silver 7. Base finish 8. <i>Optional non-beltway panels:</i> specify (M) for panel frame to be milled for ported components, \$14 list upcharge applicable	1. <i>Top trim profile:</i> A = Flat B = Square C = Bullnose E = Extruded Aluminum  2. <i>Base height:</i> 4 = 4" base height  Applicable finishes are listed on page 5 and 6.  Product on this page will accept wood grain laminate where laminate is currently an option. Panel product is subject to a 10% upcharge on the base panel price. Refer to panel product upcharge table.  The panels on this page will accept stacking modules to increase their height on 18" to 48"W panels only. The 60" to 72"W panels will not accept stacking modules on top of themselves. Fabric and veneer covers of 60", 66" and 72" wide panels are two pieces, split vertically  Product on this page can be attached to posts 49", 64", and 79"H as well as panels 42", 49", 64" and 79"H. Panels on this page will not attach to panels made before April 1997 without an attachment kit from page 117.  Remember to specify Beltway paint finish when applicable.  *These panel widths do not accept stacking modules.  79"H hookstrip reveal strips are ordered separately from page 117 at no charge.

# Monolithic panels 64" H fabric both sides

description	w	h	pattern no.	grade						
				10	15	20	30	35	40	45
Monolithic, fabric both sides	18"	64"	<b>R3B0PFF64 18-( ) ( )</b>	\$692.	\$724.	\$792.	\$926.	\$1,020.	\$1,144.	\$1,224.
Regular acoustics	20"	64"	<b>R3B0PFF64 20-( ) ( )</b>	692.	724.	792.	926.	1,020.	1,144.	1,224.
	24"	64"	<b>R3B0PFF64 24-( ) ( )</b>	734.	766.	834.	968.	1,062.	1,186.	1,266.
	30"	64"	<b>R3B0PFF64 30-( ) ( )</b>	788.	820.	888.	1,022.	1,116.	1,240.	1,320.
	36"	64"	<b>R3B0PFF64 36-( ) ( )</b>	809.	841.	909.	1,043.	1,137.	1,261.	1,341.
	42"	64"	<b>R3B0PFF64 42-( ) ( )</b>	941.	973.	1,041.	1,175.	1,269.	1,393.	1,473.
	48"	64"	<b>R3B0PFF64 48-( ) ( )</b>	996.	1,028.	1,096.	1,230.	1,324.	1,448.	1,528.
	60"	64"	<b>R3B0PFF64 60-( ) ( ) *</b>	1,154.	1,228.	1,354.	1,638.	1,834.	2,078.	2,240.
	66"	64"	<b>R3B0PFF64 66-( ) ( ) *</b>	1,191.	1,265.	1,391.	1,675.	1,871.	2,115.	2,277.
	72"	64"	<b>R3B0PFF64 72-( ) ( ) *</b>	1,230.	1,304.	1,430.	1,714.	1,910.	2,154.	2,316.
Monolithic, fabric both sides	18"	64"	<b>R3B0PAA64 18-( ) ( )</b>	753.	785.	853.	987.	1,081.	1,205.	1,285.
High acoustics	20"	64"	<b>R3B0PAA64 20-( ) ( )</b>	753.	785.	853.	987.	1,081.	1,205.	1,285.
	24"	64"	<b>R3B0PAA64 24-( ) ( )</b>	804.	836.	904.	1,038.	1,132.	1,256.	1,336.
	30"	64"	<b>R3B0PAA64 30-( ) ( )</b>	862.	894.	962.	1,096.	1,190.	1,314.	1,394.
	36"	64"	<b>R3B0PAA64 36-( ) ( )</b>	883.	915.	983.	1,117.	1,211.	1,335.	1,415.
	42"	64"	<b>R3B0PAA64 42-( ) ( )</b>	1,033.	1,065.	1,133.	1,267.	1,361.	1,485.	1,565.
	48"	64"	<b>R3B0PAA64 48-( ) ( )</b>	1,093.	1,125.	1,193.	1,327.	1,421.	1,545.	1,625.
	60"	64"	<b>R3B0PAA64 60-( ) ( ) *</b>	1,253.	1,327.	1,453.	1,737.	1,933.	2,177.	2,339.
	66"	64"	<b>R3B0PAA64 66-( ) ( ) *</b>	1,295.	1,369.	1,495.	1,779.	1,975.	2,219.	2,381.
	72"	64"	<b>R3B0PAA64 72-( ) ( ) *</b>	1,337.	1,411.	1,537.	1,821.	2,017.	2,261.	2,423.

Order Code	Specification Information	Application Notes
Example: <b>R3B0PFF6418-A4K</b>	<i>To order please specify pattern number including:</i>	<p>1. <i>Top trim profile:</i> A = Flat B = Square C = Bullnose E = Extruded Aluminum</p> <p>2. <i>Base height:</i> 4 = 4" base height 6 = 6" base height (add \$47 per panel for this option)</p> <p>6" Raceway option increases panel height by 2 3/4".</p> <p>Applicable finishes are listed on page 5 and 6.</p>
<b>R3</b> Reff Generation 3	1. Top trim profile	
<b>B0</b> No Beltway	2. Base height	
<b>P</b> Monolithic panel	3. Knockout option (K = with knockouts, N = without knockouts)	
<b>FF</b> Fabric on both sides	4. Panel side 1 finish(s) inside	
<b>64</b> 64" high	5. Panel side 2 finish(s) outside	
<b>18</b> 18" wide	6. Top trim finish i) Top trim profile A,B or C options: V1, V2, V3, P1, P2, P3 finishes	
<b>A</b> Flat style top trim profile	ii) Top trim profile E options: AA-anodized aluminum or P1, P2, P3 finish listed on page 5 excluding silver	
<b>4</b> 4" base height	7. Base finish	<p>The panels on this page will accept stacking modules to increase their height on 18" to 48"W panels only. The 60" to 72"W panels will not accept stacking modules on top of themselves. Fabric covers of 60", 66" and 72" wide panels are two pieces, split vertically.</p> <p>Product on this page can be attached to posts 64", and 79"H as well as panels 42", 49", 64" and 79"H. Panels on this page will not attach to panels made before April 1997 without an attachment kit from page 117.</p> <p>Remember to specify Beltway paint finish when applicable.</p> <p>*These panel widths do not accept stacking modules.</p> <p>79"H hookstrip reveal strips are ordered separately from page 117 at no charge.</p>
<b>K</b> Include knockouts in base	8. <i>Optional non-beltway panels:</i> specify (M) for panel frame to be milled for ported components, \$14 list upcharge applicable	
<b>W281</b> Fabric - Side 1		
<b>W281</b> Fabric - Side 2		
<b>V316</b> Maple (top trim finish)		
<b>111</b> Jet Black (base finish)		
<b>M</b> Optional milled frame		

# Monolithic panels 64" H

*fabric both sides, with Beltway*

description	w	h	pattern no.	grade						
				10	15	20	30	35	40	45
Monolithic, fabric both sides	18"	64"	<b>R3B2PFF64 18-( ) ( )</b>	\$1,186.	\$1,222.	\$1,302.	\$1,468.	\$1,572.	\$1,724.	\$1,824.
Beltway two sides, regular acoustics	20"	64"	<b>R3B2PFF64 20-( ) ( )</b>	1,186.	1,222.	1,302.	1,468.	1,572.	1,724.	1,824.
	24"	64"	<b>R3B2PFF64 24-( ) ( )</b>	1,244.	1,280.	1,360.	1,526.	1,630.	1,782.	1,882.
	30"	64"	<b>R3B2PFF64 30-( ) ( )</b>	1,273.	1,309.	1,389.	1,555.	1,659.	1,811.	1,911.
	36"	64"	<b>R3B2PFF64 36-( ) ( )</b>	1,540.	1,576.	1,656.	1,822.	1,926.	2,078.	2,178.
	42"	64"	<b>R3B2PFF64 42-( ) ( )</b>	1,648.	1,684.	1,764.	1,930.	2,034.	2,186.	2,286.
	48"	64"	<b>R3B2PFF64 48-( ) ( )</b>	1,703.	1,739.	1,819.	1,985.	2,089.	2,241.	2,341.

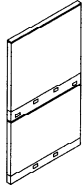

Monolithic, fabric both sides	18"	64"	<b>R3B1PFF64 18-( ) ( )</b>	1,161.	1,195.	1,269.	1,419.	1,518.	1,656.	1,746.
Beltway one side	20"	64"	<b>R3B1PFF64 20-( ) ( )</b>	1,161.	1,195.	1,269.	1,419.	1,518.	1,656.	1,746.
	24"	64"	<b>R3B1PFF64 24-( ) ( )</b>	1,214.	1,248.	1,322.	1,472.	1,571.	1,709.	1,799.
	30"	64"	<b>R3B1PFF64 30-( ) ( )</b>	1,242.	1,276.	1,350.	1,500.	1,599.	1,737.	1,827.
	36"	64"	<b>R3B1PFF64 36-( ) ( )</b>	1,508.	1,542.	1,616.	1,766.	1,865.	2,003.	2,093.
	42"	64"	<b>R3B1PFF64 42-( ) ( )</b>	1,612.	1,646.	1,720.	1,870.	1,969.	2,107.	2,197.
	48"	64"	<b>R3B1PFF64 48-( ) ( )</b>	1,662.	1,696.	1,770.	1,920.	2,019.	2,157.	2,247.

Order Code	Specification Information	Application Notes
Example: <b>R3B2PFF6418-A4K</b>	<i>To order please specify pattern number including:</i>	
<b>R3</b> Reff Generation 3	1. Top trim profile	1. Top trim profile:
<b>B2</b> Beltway both sides, B1=Beltway, one side	2. Base height	A = Flat
<b>P</b> Monolithic panel	3. Knockout option (K = with knockouts, N = without knockouts)	B = Square
<b>FF</b> Fabric on both sides	4. Panel side 1 finish(s) Below Belt	C = Bullnose
<b>64</b> 64" high	5. Panel side 1 finish(s) Above Belt	E = Extruded Aluminum
<b>18</b> 18" wide	6. Panel side 2 finish(s) Below Belt	2. Base height:
<b>A</b> Flat style top trim profile	7. Panel side 2 finish(s) Above Belt	4 = 4" base height
<b>4</b> 4" base height	8. Base finish	6 = 6" base height (add \$47 per panel for this option)
<b>K</b> Include knockouts in base	9. Beltway finish	Beltways;
<b>W281</b> Fabric - Side 1 Below belt	10. <i>Optional non-beltway panels:</i> specify (M) for panel frame to be milled for ported components, \$14 list upcharge applicable	B1 = Beltway 1 side
<b>W281</b> Fabric - Side 1 Above belt		B2 = Beltway 2 side
<b>W281</b> Fabric - Side 2 Below belt		6" Raceway option increases panel height by 2 3/4".
<b>W281</b> Fabric - Side 2 Above belt		Applicable finishes are listed on page 5 and 6.
<b>V316</b> Maple (top trim finish)		The panels on this page will accept stacking modules to increase their height on 18" to 48"W panels only. The 60" to 72"W panels will not accept stacking modules on top of themselves. Fabric covers of 60", 66" and 72" wide panels are two pieces, split vertically.
<b>111</b> Jet Black (base finish)		Product on this page can be attached to posts 64", and 79"H as well as panels 42", 49", 64" and 79"H. Panels on this page will not attach to panels made before April 1997 without an attachment kit from page 117.
<b>111</b> Beltway finish		Remember to specify Beltway paint finish when applicable.
		*These panel widths do not accept stacking modules.
		79"H hookstrip reveal strips are ordered separately from page 117 at no charge.

# Monolithic panels 64" H

*fabric one side, laminate other side*

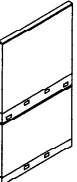
description	w	h	pattern no.	grade						
				10	15	20	30	35	40	45
Monolithic, fabric one side Regular acoustics 	18"	64"	<b>R3B0PFL64 18-( ) ( )</b>	\$607.	\$622.	\$650.	\$711.	\$752.	\$807.	\$843.
	20"	64"	<b>R3B0PFL64 20-( ) ( )</b>	607.	622.	650.	711.	752.	807.	843.
	24"	64"	<b>R3B0PFL64 24-( ) ( )</b>	667.	682.	710.	771.	812.	867.	903.
	30"	64"	<b>R3B0PFL64 30-( ) ( )</b>	753.	768.	796.	857.	898.	953.	989.
	36"	64"	<b>R3B0PFL64 36-( ) ( )</b>	811.	826.	854.	915.	956.	1,011.	1,047.
	42"	64"	<b>R3B0PFL64 42-( ) ( )</b>	900.	915.	943.	1,004.	1,045.	1,100.	1,136.
	48"	64"	<b>R3B0PFL64 48-( ) ( )</b>	1,012.	1,027.	1,055.	1,116.	1,157.	1,212.	1,248.
	60"	64"	<b>R3B0PFL64 60-( ) ( ) *</b>	1,097.	1,129.	1,186.	1,312.	1,397.	1,506.	1,577.
	66"	64"	<b>R3B0PFL64 66-( ) ( ) *</b>	1,134.	1,166.	1,223.	1,349.	1,434.	1,543.	1,614.
	72"	64"	<b>R3B0PFL64 72-( ) ( ) *</b>	1,171.	1,203.	1,260.	1,386.	1,471.	1,580.	1,651.
Monolithic fabric one side Beltway one side (fabric side) 	18"	64"	<b>R3B1PFL64 18-( ) ( )</b>	1,028.	1,045.	1,080.	1,154.	1,200.	1,265.	1,312.
	20"	64"	<b>R3B1PFL64 20-( ) ( )</b>	1,028.	1,045.	1,080.	1,154.	1,200.	1,265.	1,312.
	24"	64"	<b>R3B1PFL64 24-( ) ( )</b>	1,098.	1,115.	1,150.	1,224.	1,270.	1,335.	1,382.
	30"	64"	<b>R3B1PFL64 30-( ) ( )</b>	1,163.	1,180.	1,215.	1,289.	1,335.	1,400.	1,447.
	36"	64"	<b>R3B1PFL64 36-( ) ( )</b>	1,445.	1,462.	1,497.	1,571.	1,617.	1,682.	1,729.
	42"	64"	<b>R3B1PFL64 42-( ) ( )</b>	1,501.	1,518.	1,553.	1,627.	1,673.	1,738.	1,785.
	48"	64"	<b>R3B1PFL64 48-( ) ( )</b>	1,623.	1,640.	1,675.	1,749.	1,795.	1,860.	1,907.

Order Code	Specification Information	Application Notes
Example: <b>R3B0PFL6418-A4K</b> <b>R3</b> Reff Generation 3 <b>B0</b> No Beltway <b>P</b> Monolithic panel <b>FL</b> Fabric one side, laminate other <b>64</b> 64" high <b>18</b> 18" wide <b>A</b> Flat style top trim profile <b>4</b> 4" base height <b>K</b> Include knockouts in base <b>W281</b> Fabric - Side 1 <b>114</b> Folkstone grey - side 2 <b>V316</b> Maple (top trim finish) <b>111</b> Jet Black (base finish) <b>M</b> Optional milled frame	To order please specify pattern number including: 1. Top trim profile 2. Base height 3. Knockout option (K = with knockouts, N = without knockouts) 4. Panel side 1 finish(s) inside For panels with Beltway, please specify: Side 1-Below belt Side 1-Above belt 5. Panel side 2 finish(s) outside 6. Top trim finish i) Top trim profile A, B or C options: V1, V2, V3, P1, P2, P3 finishes ii) Top trim profile E options: AA-anodized aluminum or P1, P2, P3 finish listed on page 5 excluding silver 7. Base finish 8. Beltway finish - only for panels with Beltway 9. <i>Optional non-beltway panels:</i> specify (M) for panel frame to be milled for ported components, \$14 list upcharge applicable	1. <i>Top trim profile:</i> A = Flat B = Square C = Bullnose E = Extruded Aluminum 2. <i>Base height:</i> 4 = 4" base height 6 = 6" base height (add \$47 per panel for this option) 3. <i>Beltway:</i> B0 = No Beltway B1 = Beltway 1 side 6" Raceway option increases panel height by 2 3/4". Applicable finishes are listed on page 5 and 6. Product on this page will accept wood grain laminate where laminate is currently an option. Panel product is subject to a 10% upcharge on the base panel price. Refer to panel product upcharge table. The panels on this page will accept stacking modules to increase their height on 18" to 48"W panels only. The 60" to 72"W panels will not accept stacking modules on top of themselves. Fabric and laminate covers of 60", 66" and 72" wide panels are two pieces, split vertically. Product on this page can be attached to posts 64", and 79"H as well as panels 42", 49", 64" and 79"H. Panels on this page will not attach to panels made before April 1997 without an attachment kit from page 117. Remember to specify Beltway paint finish when applicable. *These panel widths do not accept stacking modules. 79"H hookstrip reveal strips are ordered separately from page 117 at no charge.



# Monolithic panels 64" H

*fabric one side, techwood other side*

description	w	h	pattern no.	grade						
				10	15	20	30	35	40	45
Monolithic, fabric one side Regular acoustics 	18"	64"	<b>R3B0PF164 18-( )</b> ( )	\$713.	\$729.	\$764.	\$833.	\$880.	\$944.	\$986.
	20"	64"	<b>R3B0PF164 20-( )</b> ( )	713.	729.	764.	833.	880.	944.	986.
	24"	64"	<b>R3B0PF164 24-( )</b> ( )	782.	798.	833.	902.	949.	1,013.	1,055.
	30"	64"	<b>R3B0PF164 30-( )</b> ( )	885.	901.	936.	1,005.	1,052.	1,116.	1,158.
	36"	64"	<b>R3B0PF164 36-( )</b> ( )	956.	972.	1,007.	1,076.	1,123.	1,187.	1,229.
	42"	64"	<b>R3B0PF164 42-( )</b> ( )	1,058.	1,074.	1,109.	1,178.	1,225.	1,289.	1,331.
	48"	64"	<b>R3B0PF164 48-( )</b> ( )	1,192.	1,208.	1,243.	1,312.	1,359.	1,423.	1,465.
	60"	64"	<b>R3B0PF164 60-( )</b> ( )*	1,289.	1,327.	1,392.	1,537.	1,635.	1,762.	1,844.
	66"	64"	<b>R3B0PF164 66-( )</b> ( )*	1,334.	1,372.	1,437.	1,582.	1,680.	1,807.	1,889.
	72"	64"	<b>R3B0PF164 72-( )</b> ( )*	1,378.	1,416.	1,481.	1,626.	1,724.	1,851.	1,933.

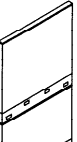
Monolithic fabric one side Beltway one side (fabric side) 	18"	64"	<b>R3B1PF164 18-( )</b> ( )	1,210.	1,226.	1,268.	1,352.	1,404.	1,481.	1,535.
	20"	64"	<b>R3B1PF164 20-( )</b> ( )	1,210.	1,226.	1,268.	1,352.	1,404.	1,481.	1,535.
	24"	64"	<b>R3B1PF164 24-( )</b> ( )	1,289.	1,305.	1,347.	1,431.	1,483.	1,560.	1,614.
	30"	64"	<b>R3B1PF164 30-( )</b> ( )	1,368.	1,384.	1,426.	1,510.	1,562.	1,639.	1,693.
	36"	64"	<b>R3B1PF164 36-( )</b> ( )	1,699.	1,715.	1,757.	1,841.	1,893.	1,970.	2,024.
	42"	64"	<b>R3B1PF164 42-( )</b> ( )	1,767.	1,783.	1,825.	1,909.	1,961.	2,038.	2,092.
	48"	64"	<b>R3B1PF164 48-( )</b> ( )	1,909.	1,925.	1,967.	2,051.	2,103.	2,180.	2,234.

Order Code	Specification Information	Application Notes
Example: <b>R3B0PF16418-A4K</b>	<i>To order please specify pattern number including:</i>	<i>1. Top trim profile:</i>
<b>R3</b> Reff Generation 3	1. Top trim profile	A = Flat
<b>B0</b> No Beltway	2. Base height	B = Square
<b>P</b> Monolithic panel	3. Knockout option	C = Bullnose
<b>F1</b> Fabric one side, V1 other	(K = with knockouts, N = without knockouts)	E = Extruded Aluminum
<b>64</b> 64" high	4. Panel side 1 finish(s) inside	<i>2. Base height:</i>
<b>18</b> 18" wide	For panels with Beltway, please specify;	4 = 4" base height
<b>A</b> Flat style top trim profile	Side 1 - Below Belt	6 = 6" base height (add \$47 per panel for this option)
<b>4</b> 4" base height	Side 1 - Above Belt	<i>3. Beltway:</i>
<b>K</b> Include knockouts in base	5. Panel side 2 finish(s) outside	B0 = No Beltway
<b>W281</b> Fabric - Side 1	6. Top trim finish	B1 = Beltway 1 side
<b>Y328</b> Mahogany - side 2	i) Top trim profile A, B or C options:	<i>6" Raceway option increases panel height by 2 3/4".</i>
<b>V316</b> Maple (top trim finish)	V1, V2, V3, P1, P2, P3 finishes	Applicable finishes are listed on page 5 and 6.
<b>111</b> Jet Black (base finish)	ii) Top trim profile E options:	
<b>M</b> Optional milled frame	AA-anodized aluminum or P1, P2, P3 finish listed on page 5 excluding silver	
	7. Base finish	
	8. Beltway finish - only for panels with Beltway	
	9. <i>Optional non-beltway panels:</i> specify (M) for panel frame to be milled for ported components, \$14 list upcharge applicable	

The panels on this page will accept stacking modules to increase their height on 18" to 48"W panels only. The 60" to 72"W panels will not accept stacking modules on top of themselves. Fabric and techwood covers of 60", 66" and 72" wide panels are two pieces, split vertically.

Product on this page can be attached to posts 64", and 79"H as well as panels 42", 49", 64" and 79"H. Panels on this page will not attach to panels made before April 1997 without an attachment kit from page 117.

Remember to specify Beltway paint finish when applicable.

\*These panel widths do not accept stacking modules.

79"H hookstrip reveal strips are ordered separately from page 117 at no charge.

# Monolithic panels 64" H

*fabric one side, conventional veneer other side*

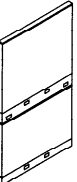
description	w	h	pattern no.	grade						
				10	15	20	30	35	40	45
Monolithic, fabric one side Regular acoustics 	18"	64"	<b>R3B0PF264 18-()</b> ( )	\$727.	\$743.	\$778.	\$847.	\$894.	\$958.	\$1,000.
	20"	64"	<b>R3B0PF264 20-()</b> ( )	727.	743.	778.	847.	894.	958.	1,000.
	24"	64"	<b>R3B0PF264 24-()</b> ( )	796.	812.	847.	916.	963.	1,027.	1,069.
	30"	64"	<b>R3B0PF264 30-()</b> ( )	901.	917.	952.	1,021.	1,068.	1,132.	1,174.
	36"	64"	<b>R3B0PF264 36-()</b> ( )	971.	987.	1,022.	1,091.	1,138.	1,202.	1,244.
	42"	64"	<b>R3B0PF264 42-()</b> ( )	1,076.	1,092.	1,127.	1,196.	1,243.	1,307.	1,349.
	48"	64"	<b>R3B0PF264 48-()</b> ( )	1,215.	1,231.	1,266.	1,335.	1,382.	1,446.	1,488.
	60"	64"	<b>R3B0PF264 60-()</b> ( ) *	1,309.	1,347.	1,412.	1,557.	1,655.	1,782.	1,864.
	66"	64"	<b>R3B0PF264 66-()</b> ( ) *	1,355.	1,393.	1,458.	1,603.	1,701.	1,828.	1,910.
	72"	64"	<b>R3B0PF264 72-()</b> ( ) *	1,403.	1,441.	1,506.	1,651.	1,749.	1,876.	1,958.
Monolithic fabric one side Beltway one side (fabric side) 	18"	64"	<b>R3B1PF264 18-()</b> ( )	1,231.	1,247.	1,289.	1,373.	1,425.	1,502.	1,556.
	20"	64"	<b>R3B1PF264 20-()</b> ( )	1,231.	1,247.	1,289.	1,373.	1,425.	1,502.	1,556.
	24"	64"	<b>R3B1PF264 24-()</b> ( )	1,314.	1,330.	1,372.	1,456.	1,508.	1,585.	1,639.
	30"	64"	<b>R3B1PF264 30-()</b> ( )	1,393.	1,409.	1,451.	1,535.	1,587.	1,664.	1,718.
	36"	64"	<b>R3B1PF264 36-()</b> ( )	1,727.	1,743.	1,785.	1,869.	1,921.	1,998.	2,052.
	42"	64"	<b>R3B1PF264 42-()</b> ( )	1,799.	1,815.	1,857.	1,941.	1,993.	2,070.	2,124.
	48"	64"	<b>R3B1PF264 48-()</b> ( )	1,944.	1,960.	2,002.	2,086.	2,138.	2,215.	2,269.

Order Code	Specification Information	Application Notes
Example: <b>R3B0PF26418-A4K</b> <b>R3</b> Reff Generation 3 <b>B0</b> No Beltway <b>P</b> Monolithic panel <b>F2</b> Fabric one side, V2 other <b>64</b> 64" high <b>18</b> 18" wide <b>A</b> Flat style top trim profile <b>4</b> 4" base height <b>K</b> Include knockouts in base <b>W281</b> Fabric - Side 1 <b>V316</b> Maple surface - side 2 <b>V316</b> Maple (top trim finish) <b>111</b> Jet Black (base finish) <b>M</b> Optional milled frame	To order please specify pattern number including: 1. Top trim profile 2. Base height 3. Knockout option (K = with knockouts, N = without knockouts) 4. Panel side 1 finish(s) inside For panels with Beltway, please specify; Side 1 - Below Belt Side 1 - Above Belt 5. Panel side 2 finish(s) outside 6. Top trim finish i) Top trim profile A, B or C options: V1, V2, V3, P1, P2, P3 finishes ii) Top trim profile E options: AA-anodized aluminum or P1, P2, P3 finish listed on page 5 excluding silver 7. Base finish 8. Beltway finish - only for panels with Beltway 9. <i>Optional non-beltway panels:</i> specify (M) for panel frame to be milled for ported components, \$14 list upcharge applicable	1. <i>Top trim profile:</i> A = Flat B = Square C = Bullnose E = Extruded Aluminum 2. <i>Base height:</i> 4 = 4" base height 6 = 6" base height (add \$47 per panel for this option) 3. <i>Beltway:</i> B0 = No Beltway B1 = Beltway 1 side 6" Raceway option increases panel height by 2 3/4". Applicable finishes are listed on page 5 and 6. The panels on this page will accept stacking modules to increase their height on 18" to 48"W panels only. The 60" to 72"W panels will not accept stacking modules on top of themselves. Fabric and veneer covers of 60", 66" and 72" wide panels are two pieces, split vertically. Product on this page can be attached to posts 64", and 79"H as well as panels 42", 49", 64" and 79"H. Panels on this page will not attach to panels made before April 1997 without an attachment kit from page 117. Remember to specify Beltway paint finish when applicable. *These panel widths do not accept stacking modules. 79"H hookstrip reveal strips are ordered separately from page 117 at no charge.

# Monolithic panels 64" H

*fabric one side, exotic veneer other side*

description	w	h	pattern no.	grade						
				10	15	20	30	35	40	45
Monolithic, fabric one side Regular acoustics 	18"	64"	<b>R3B0PF364 18-( ) ( )</b>	\$959.	\$975.	\$1,010.	\$1,079.	\$1,126.	\$1,190.	\$1,232.
	20"	64"	<b>R3B0PF364 20-( ) ( )</b>	959.	975.	1,010.	1,079.	1,126.	1,190.	1,232.
	24"	64"	<b>R3B0PF364 24-( ) ( )</b>	1,052.	1,068.	1,103.	1,172.	1,219.	1,283.	1,325.
	30"	64"	<b>R3B0PF364 30-( ) ( )</b>	1,191.	1,207.	1,242.	1,311.	1,358.	1,422.	1,464.
	36"	64"	<b>R3B0PF364 36-( ) ( )</b>	1,287.	1,303.	1,338.	1,407.	1,454.	1,518.	1,560.
	42"	64"	<b>R3B0PF364 42-( ) ( )</b>	1,430.	1,446.	1,481.	1,550.	1,597.	1,661.	1,703.
	48"	64"	<b>R3B0PF364 48-( ) ( )</b>	1,616.	1,632.	1,667.	1,736.	1,783.	1,847.	1,889.
	60"	64"	<b>R3B0PF364 60-( ) ( )*</b>	1,721.	1,759.	1,824.	1,969.	2,067.	2,194.	2,276.
	66"	64"	<b>R3B0PF364 66-( ) ( )*</b>	1,784.	1,822.	1,887.	2,032.	2,130.	2,257.	2,339.
	72"	64"	<b>R3B0PF364 72-( ) ( )*</b>	1,848.	1,886.	1,951.	2,096.	2,194.	2,321.	2,403.

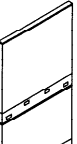
Monolithic, fabric one side Beltway fabric side 	18"	64"	<b>R3B1PF364 18-( ) ( )</b>	1,636.	1,652.	1,694.	1,778.	1,830.	1,907.	1,961.
	20"	64"	<b>R3B1PF364 20-( ) ( )</b>	1,636.	1,652.	1,694.	1,778.	1,830.	1,907.	1,961.
	24"	64"	<b>R3B1PF364 24-( ) ( )</b>	1,747.	1,763.	1,805.	1,889.	1,941.	2,018.	2,072.
	30"	64"	<b>R3B1PF364 30-( ) ( )</b>	1,855.	1,871.	1,913.	1,997.	2,049.	2,126.	2,180.
	36"	64"	<b>R3B1PF364 36-( ) ( )</b>	2,307.	2,323.	2,365.	2,449.	2,501.	2,578.	2,632.
	42"	64"	<b>R3B1PF364 42-( ) ( )</b>	2,402.	2,418.	2,460.	2,544.	2,596.	2,673.	2,727.
	48"	64"	<b>R3B1PF364 48-( ) ( )</b>	2,599.	2,615.	2,657.	2,741.	2,793.	2,870.	2,924.

Order Code	Specification Information
Example: <b>R3B0PF36418-A4K</b>	
<b>R3</b>	Reff Generation 3
<b>B0</b>	No Beltway
<b>P</b>	Monolithic panel
<b>F3</b>	Fabric one side, V3 other
<b>64</b>	64" high
<b>18</b>	18" wide
<b>A</b>	Flat style top trim profile
<b>4</b>	4" base height
<b>K</b>	Include knockouts in base
<b>W281</b>	Fabric - Side 1
<b>V512</b>	Figured Anigre surface - side 2
<b>V512</b>	Figured Anigre (top trim finish)
<b>111</b>	Jet Black (base finish)
<b>M</b>	Optional milled frame

Specification Information
<i>To order please specify pattern number including:</i>
1. Top trim profile
2. Base height
3. Knockout option (K = with knockouts, N = without knockouts)
4. Panel side 1 finish(s) inside For panels with beltway, please specify; Side 1 - Below belt Side 1 - Above belt
5. Panel side 2 finish(s) outside
6. Top trim finish i) Top trim profile A, B or C options: V1, V2, V3, P1, P2, P3 finishes ii) Top trim profile E options: AA-anodized aluminum or P1, P2, P3 finish listed on page 5 excluding silver
7. Base finish
8. Beltway finish - only for panels with Beltway
9. <i>Optional non-beltway panels:</i> specify (M) for panel frame to be milled for ported components, \$14 list upcharge applicable

Application Notes
1. <i>Top trim profile:</i> A = Flat B = Square C = Bullnose E = Extruded Aluminum
2. <i>Base height:</i> 4 = 4" base height 6 = 6" base height (add \$47 per panel for this option)
3. <i>Beltway:</i> B0 = No Beltway B1 = Beltway 1 side
6" Raceway option increases panel height by 2 3/4".
Applicable finishes are listed on page 5 and 6.

The panels on this page will accept stacking modules to increase their height on 18" to 48"W panels only. The 60" to 72"W panels will not accept stacking modules on top of themselves. Fabric and veneer covers of 60", 66" and 72" wide panels are two pieces, split vertically.

Product on this page can be attached to posts 64", and 79"H as well as panels 42", 49", 64" and 79"H. Panels on this page will not attach to panels made before April 1997 without an attachment kit from page 117.

Remember to specify Beltway paint finish when applicable.

\*These panel widths do not accept stacking modules.

79"H hookstrip reveal strips are ordered separately from page 117 at no charge.

# Monolithic panels 64" H

## Laminate/Laminate

Reff Profiles

description	w	h	pattern no.	L
Monolithic, laminate both sides with raceway both sides 	18"	64"	<b>R3B0PLL6418( )()</b>	\$809.
	20"	64"	<b>R3B0PLL6420( )()</b>	809.
	24"	64"	<b>R3B0PLL6424( )()</b>	882.
	30"	64"	<b>R3B0PLL6430( )()</b>	987.
	36"	64"	<b>R3B0PLL6436( )()</b>	1,066.
	42"	64"	<b>R3B0PLL6442( )()</b>	1,172.
	48"	64"	<b>R3B0PLL6448( )()</b>	1,313.
	60"	64"	<b>R3B0PLL6460( )()*</b>	1,418.
	66"	64"	<b>R3B0PLL6466( )()*</b>	1,461.
	72"	64"	<b>R3B0PLL6472( )()*</b>	1,505.

### Order Code

Example:	<b>R3B0PLL6418-A4K</b>
<b>R3</b>	Reff Generation 3
<b>B0</b>	No Beltway
<b>P</b>	Monolithic panel
<b>LL</b>	Laminate both sides
<b>64</b>	64" high
<b>18</b>	18" wide
<b>A</b>	Flat style top trim profile
<b>4</b>	4" base height
<b>K</b>	Include knockouts in base
<b>118</b>	Laminate - side 1
<b>118</b>	Laminate - side 2
<b>V512</b>	Figured Anigre (top trim finish)
<b>111</b>	Jet Black (base finish)
<b>M</b>	Optional milled frame

### Specification Information

To order please specify pattern number including:

1. Top trim profile
2. Base height
3. Knockout option  
(K = with knockouts, N = without knockouts)
4. Panel side 1 inside
5. Panel side 2 outside
6. Top trim finish  
i) Top trim profile A, B or C options:  
V1, V2, V3, P1, P2, P3 finishes  
ii) Top trim profile E options:  
AA-anodized aluminum or P1, P2, P3 finish listed on page 5 excluding silver
7. Base finish
8. *Optional non-beltway panels:* specify (M) for panel frame to be milled for ported components, \$14 list upcharge applicable

### Application Notes

#### 1. Top trim profile:

A = Flat  
B = Square  
C = Bullnose  
E = Extruded Aluminum

#### 2. Base height:

4 = 4" base height

Applicable finishes are listed on page 5 and 6.

Product on this page will accept wood grain laminate where laminate is currently an option. Panel product is subject to a 10% upcharge on the base panel price. Refer to panel product upcharge table.

The panels on this page will accept stacking modules to increase their height on 18" to 48"W panels only. The 60" to 72"W panels will not accept stacking modules on top of themselves. Fabric and veneer covers of 60", 66" and 72" wide panels are two pieces, split vertically.



Product on this page can be attached to posts 64", and 79"H as well as panels 42", 49", 64" and 79"H. Panels on this page will not attach to panels made before April 1997 without an attachment kit from page 117.

Remember to specify Beltway paint finish when applicable.

\*These panel widths do not accept stacking modules.

79"H hookstrip reveal strips are ordered separately from page 117 at no charge.

# Monolithic panels 79" H fabric both sides

description	w	h	pattern no.	grade							
				10	15	20	30	35	40	45	
Monolithic, fabric both sides	18"	79"	<b>R3B0PFF79 18-( ) ( )</b>	\$864.	\$910.	\$990.	\$1,158.	\$1,272.	\$1,428.	\$1,520.	
Regular acoustics	20"	79"	<b>R3B0PFF79 20-( ) ( )</b>	864.	910.	990.	1,158.	1,272.	1,428.	1,520.	
	24"	79"	<b>R3B0PFF79 24-( ) ( )</b>	919.	965.	1,045.	1,213.	1,327.	1,483.	1,575.	
	30"	79"	<b>R3B0PFF79 30-( ) ( )</b>	992.	1,038.	1,118.	1,286.	1,400.	1,556.	1,648.	
	36"	79"	<b>R3B0PFF79 36-( ) ( )</b>	1,017.	1,063.	1,143.	1,311.	1,425.	1,581.	1,673.	
	42"	79"	<b>R3B0PFF79 42-( ) ( )</b>	1,093.	1,139.	1,219.	1,387.	1,501.	1,657.	1,749.	
	48"	79"	<b>R3B0PFF79 48-( ) ( )</b>	1,211.	1,257.	1,337.	1,505.	1,619.	1,775.	1,867.	
	60"	79"	<b>R3B0PFF79 60-( ) ( )</b>	1,400.	1,492.	1,650.	1,988.	2,228.	2,532.	2,718.	
	66"	79"	<b>R3B0PFF79 66-( ) ( )</b>	1,433.	1,525.	1,683.	2,021.	2,261.	2,565.	2,751.	
	72"	79"	<b>R3B0PFF79 72-( ) ( )</b>	1,465.	1,557.	1,715.	2,053.	2,293.	2,597.	2,783.	
	Monolithic, fabric both sides	18"	79"	<b>R3B0PAA79 18-( ) ( )</b>	943.	989.	1,069.	1,237.	1,351.	1,507.	1,599.
	High acoustics	20"	79"	<b>R3B0PAA79 20-( ) ( )</b>	943.	989.	1,069.	1,237.	1,351.	1,507.	1,599.
	24"	79"	<b>R3B0PAA79 24-( ) ( )</b>	1,003.	1,049.	1,129.	1,297.	1,411.	1,567.	1,659.	
	30"	79"	<b>R3B0PAA79 30-( ) ( )</b>	1,084.	1,130.	1,210.	1,378.	1,492.	1,648.	1,740.	
	36"	79"	<b>R3B0PAA79 36-( ) ( )</b>	1,117.	1,163.	1,243.	1,411.	1,525.	1,681.	1,773.	
	42"	79"	<b>R3B0PAA79 42-( ) ( )</b>	1,198.	1,244.	1,324.	1,492.	1,606.	1,762.	1,854.	
	48"	79"	<b>R3B0PAA79 48-( ) ( )</b>	1,332.	1,378.	1,458.	1,626.	1,740.	1,896.	1,988.	
	60"	79"	<b>R3B0PAA79 60-( ) ( )</b>	1,524.	1,616.	1,774.	2,112.	2,352.	2,656.	2,842.	
	66"	79"	<b>R3B0PAA79 66-( ) ( )</b>	1,559.	1,651.	1,809.	2,147.	2,387.	2,691.	2,877.	
	72"	79"	<b>R3B0PAA79 72-( ) ( )</b>	1,592.	1,684.	1,842.	2,180.	2,420.	2,724.	2,910.	

Order Code	Specification Information	Application Notes
Example: <b>R3B0PFF7918-A4K</b>	<i>To order please specify pattern number including:</i>	
<b>R3</b> Reff Generation 3	1. Top trim profile	1. <i>Top trim profile:</i> A = Flat B = Square C = Bullnose E = Extruded Aluminum
<b>B0</b> No Beltway	2. Base height	2. <i>Base height:</i> 4 = 4" base height 6 = 6" base height (add \$47 per panel for this option)
<b>P</b> Monolithic panel	3. Knockout option (K = with knockouts, N = without knockouts)	
<b>FF</b> Fabric on both sides	4. Panel side 1 finish(s) inside	
<b>79</b> 79" high	5. Panel side 2 finish(s) outside	
<b>18</b> 18" wide	6. Top trim finish i) Top trim profile A,B or C options: V1, V2, V3, P1, P2, P3 finishes ii) Top trim profile E options: AA-anodized aluminum or P1, P2, P3 finish listed on page 5 excluding silver	
<b>A</b> Flat style top trim profile	7. Base finish	
<b>4</b> 4" base height	8. <i>Optional:</i> specify (M) for panel frame to be milled for ported components. \$14 list upcharge applicable	
<b>K</b> Include knockouts in base		
<b>W281</b> Fabric - Side 1		
<b>W281</b> Fabric - Side 2		
<b>V316</b> Maple (top trim finish)		
<b>111</b> Jet Black (base finish)		
<b>M</b> Optional milled profile		

The panels on this page are not designed to be stacked upon.

Fabric covers of 60", 66" and 72" wide panels are two pieces, split vertically.

6" Raceway option increases panel height by 2 3/4".

Product on this page can be attached to posts 79"H as well as panels 42", 49", 64" and 79"H. Panels on this page will not attach to panels made before April 1997 without an attachment kit from page 117.

Remember to specify Beltway paint finish when applicable.

79"H hookstrip reveal strips are ordered separately from page 117 at no charge.

# Monolithic panels 79" H

*fabric both sides with Beltway*

description	w	h	pattern n	grade						
				10	15	20	30	35	40	45
Monolithic, fabric both sides Beltway one side	18"	79"	<b>R3B1PFF79 18-()</b> ( )	\$1,243.	\$1,291.	\$1,380.	\$1,569.	\$1,691.	\$1,865.	\$1,974.
	20"	79"	<b>R3B1PFF79 20-()</b> ( )	1,243.	1,291.	1,380.	1,569.	1,691.	1,865.	1,974.
	24"	79"	<b>R3B1PFF79 24-()</b> ( )	1,300.	1,348.	1,437.	1,626.	1,748.	1,922.	2,031.
	30"	79"	<b>R3B1PFF79 30-()</b> ( )	1,326.	1,374.	1,463.	1,652.	1,774.	1,948.	2,057.
	36"	79"	<b>R3B1PFF79 36-()</b> ( )	1,591.	1,639.	1,728.	1,917.	2,039.	2,213.	2,322.
	42"	79"	<b>R3B1PFF79 42-()</b> ( )	1,695.	1,743.	1,832.	2,021.	2,143.	2,317.	2,426.
	48"	79"	<b>R3B1PFF79 48-()</b> ( )	1,746.	1,794.	1,883.	2,072.	2,194.	2,368.	2,477.

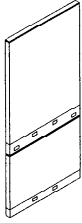

Monolithic, fabric both sides Beltway two sides	18"	79"	<b>R3B2PFF79 18-()</b> ( )	1,307.	1,357.	1,455.	1,665.	1,795.	1,987.	2,113.
	20"	79"	<b>R3B2PFF79 20-()</b> ( )	1,307.	1,357.	1,455.	1,665.	1,795.	1,987.	2,113.
	24"	79"	<b>R3B2PFF79 24-()</b> ( )	1,363.	1,413.	1,511.	1,721.	1,851.	2,043.	2,169.
	30"	79"	<b>R3B2PFF79 30-()</b> ( )	1,391.	1,441.	1,539.	1,749.	1,879.	2,071.	2,197.
	36"	79"	<b>R3B2PFF79 36-()</b> ( )	1,660.	1,710.	1,808.	2,018.	2,148.	2,340.	2,466.
	42"	79"	<b>R3B2PFF79 42-()</b> ( )	1,766.	1,816.	1,914.	2,124.	2,254.	2,446.	2,572.
	48"	79"	<b>R3B2PFF79 48-()</b> ( )	1,821.	1,871.	1,969.	2,179.	2,309.	2,501.	2,627.

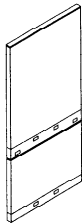

Order Code	Specification Information	Application Notes
Example: <b>R3B1PFF7918-A4K</b>	<i>To order please specify pattern number including:</i>	<i>1. Top trim profile:</i>
<b>R3</b> Reff Generation 3	1. Top trim profile	A = Flat
<b>B1</b> Beltway one side	2. Base height	B = Square
<b>P</b> Monolithic panel	3. Knockout option	C = Bullnose
<b>FF</b> Fabric on both sides	(K = with knockouts, N = without knockouts)	E = Extruded Aluminum
<b>79</b> 79" high	4. Panel side 1 below belt	<i>2. Base height:</i>
<b>18</b> 18" wide	5. Panel side 1 above belt	4 = 4" base height
<b>A</b> Flat style top trim	6. Panel side 2 below belt	6 = 6" base height (add \$47 per panel for this option)
<b>4</b> 4" base height	7. Panel side 2 above belt	<i>3. Beltway:</i>
<b>K</b> Include knockouts in base	8. Top trim finish	B1 = Beltway 1 side
<b>W281</b> Fabric - Side 1 below belt	i)Top trim profile A,B or C options:	B2 = Beltway 2 sides
<b>W281</b> Fabric - Side 1 above belt	V1, V2, V3, P1, P2, P3 finishes	Applicable finishes are listed on page 5 and 6.
<b>W281</b> Fabric - Side 2 below belt	ii)Top trim profile E options:	
<b>W281</b> Fabric - Side 2 above belt	AA-anodized aluminum or P1, P2, P3 finish listed on page 5 excluding silver	
<b>V316</b> Maple (top trim finish)	9. Base finish	
<b>111</b> Jet Black (base finish)	10. Beltway finish	
<b>111</b> Beltway finish	11. <i>Optional:</i> specify (M) for panel frame to be milled for ported components. \$14 list upcharge applicable	

The panels on this page are not designed to be stacked upon.

Fabric covers of 60", 66" and 72" wide panels are two pieces, split vertically.

6" Raceway option increases panel height by 2 3/4".

Product on this page can be attached to posts 79"H as well as panels 42", 49", 64" and 79"H . Panels on this page will not attach to panels made before April 1997 without an attachment kit from page 117.

Remember to specify Beltway paint finish when applicable.

79"H hookstrip reveal strips are ordered separately from page 117 at no charge.

# Monolithic panels 79" H

*fabric one side, laminate other side*

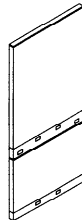
description	w	h	pattern no.	grade						
				10	15	20	30	35	40	45
Monolithic, fabric one side Regular acoustics 	18"	79"	<b>R3B0PFL79 18-()</b> ( )	\$766.	\$786.	\$821.	\$896.	\$946.	\$1,015.	\$1,056.
	20"	79"	<b>R3B0PFL79 20-()</b> ( )	766.	786.	821.	896.	946.	1,015.	1,056.
	24"	79"	<b>R3B0PFL79 24-()</b> ( )	839.	859.	894.	969.	1,019.	1,088.	1,129.
	30"	79"	<b>R3B0PFL79 30-()</b> ( )	944.	964.	999.	1,074.	1,124.	1,193.	1,234.
	36"	79"	<b>R3B0PFL79 36-()</b> ( )	1,029.	1,049.	1,084.	1,159.	1,209.	1,278.	1,319.
	42"	79"	<b>R3B0PFL79 42-()</b> ( )	1,139.	1,159.	1,194.	1,269.	1,319.	1,388.	1,429.
	48"	79"	<b>R3B0PFL79 48-()</b> ( )	1,273.	1,293.	1,329.	1,403.	1,453.	1,522.	1,563.
	60"	79"	<b>R3B0PFL79 60-()</b> ( )	1,371.	1,412.	1,481.	1,630.	1,736.	1,871.	1,952.
	66"	79"	<b>R3B0PFL79 66-()</b> ( )	1,398.	1,439.	1,508.	1,657.	1,763.	1,898.	1,979.
	72"	79"	<b>R3B0PFL79 72-()</b> ( )	1,426.	1,467.	1,536.	1,685.	1,791.	1,926.	2,007.
Monolithic, fabric one side Beltway one side (fabric side) 	18"	79"	<b>R3B1PFL79 18-()</b> ( )	1,106.	1,129.	1,172.	1,265.	1,323.	1,408.	1,464.
	20"	79"	<b>R3B1PFL79 20-()</b> ( )	1,106.	1,129.	1,172.	1,265.	1,323.	1,408.	1,464.
	24"	79"	<b>R3B1PFL79 24-()</b> ( )	1,183.	1,206.	1,249.	1,342.	1,400.	1,485.	1,541.
	30"	79"	<b>R3B1PFL79 30-()</b> ( )	1,253.	1,276.	1,319.	1,412.	1,470.	1,555.	1,611.
	36"	79"	<b>R3B1PFL79 36-()</b> ( )	1,553.	1,576.	1,619.	1,712.	1,770.	1,855.	1,911.
	42"	79"	<b>R3B1PFL79 42-()</b> ( )	1,694.	1,717.	1,760.	1,853.	1,911.	1,996.	2,052.
	48"	79"	<b>R3B1PFL79 48-()</b> ( )	1,772.	1,795.	1,838.	1,931.	1,989.	2,074.	2,130.

Order Code	Specification Information	Application Notes
Example: <b>R3B0PFL7918-A4K</b>	<i>To order please specify pattern number including:</i>	<i>1. Top trim profile:</i>
<b>R3</b> Reff Generation 3	1. Top trim profile	A = Flat
<b>B0</b> No Beltway	2. Base height	B = Square
<b>P</b> Monolithic panel	3. Knockout option	C = Bullnose
<b>FL</b> Fabric one side, laminate other	(K = with knockouts, N = without knockouts)	E = Extruded Aluminum
<b>79</b> 79" high	4. Panel side 1 finish(s) inside	<i>2. Base height:</i>
<b>18</b> 18" wide	For panels with Beltway, please specify;	4 = 4" base height
<b>A</b> Flat style top trim profile	Side 1 - Below belt	6 = 6" base height (add \$47 per panel for this option)
<b>4</b> 4" base height	Side 1 - Above belt	Applicable finishes are listed on page 5 and 6.
<b>K</b> Include knockouts in base	5. Panel side 2 finish(s) outside	Product on this page will accept wood grain laminate where laminate is currently an option.
<b>W281</b> Fabric - Side 1	6. Top trim finish	Panel product is subject to a 10% upcharge on the base panel price. Refer to panel product upcharge table.
<b>114</b> Folkstone grey - side 2	i) Top trim profile A, B or C options:	
<b>V316</b> Maple (top trim finish)	V1, V2, V3, P1, P2, P3 finishes	
<b>111</b> Jet Black (base finish)	ii) Top trim profile E options:	
<b>M</b> Optional milled frame	AA-anodized aluminum or P1, P2, P3 finish listed on page 5 excluding silver	
	7. Base finish	
	8. Beltway finish - only for panels with Beltway	
	9. <i>Optional non-beltway panels:</i> specify (M) for panel frame to be milled for ported components, \$14 list upcharge applicable	

The panels on this page are not designed to be stacked upon.

Fabric and laminate covers of 60", 66" and 72" wide panels are two pieces, split vertically.

6" Raceway option increases panel height by 2 3/4".

Product on this page can be attached to posts 79"H as well as panels 42", 49", 64" and 79"H. Panels on this page will not attach to panels made before April 1997 without an attachment kit from page 117.

Remember to specify Beltway paint finish when applicable.

79"H hookstrip reveal strips are ordered separately from page 117 at no charge.

# Monolithic panels 79" H

*fabric one side, techwood other side*

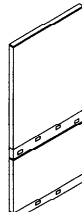
description	w	h	pattern no.	grade						
				10	15	20	30	35	40	45
Monolithic, fabric one side Regular acoustics 	18"	79"	<b>R3B0PF179 18-()</b> ( )	\$899.	\$922.	\$963.	\$1,049.	\$1,108.	\$1,186.	\$1,235.
	20"	79"	<b>R3B0PF179 20-()</b> ( )	899.	922.	963.	1,049.	1,108.	1,186.	1,235.
	24"	79"	<b>R3B0PF179 24-()</b> ( )	983.	1,006.	1,047.	1,133.	1,192.	1,270.	1,319.
	30"	79"	<b>R3B0PF179 30-()</b> ( )	1,112.	1,135.	1,176.	1,262.	1,321.	1,399.	1,448.
	36"	79"	<b>R3B0PF179 36-()</b> ( )	1,211.	1,234.	1,275.	1,361.	1,420.	1,498.	1,547.
	42"	79"	<b>R3B0PF179 42-()</b> ( )	1,337.	1,360.	1,401.	1,487.	1,545.	1,624.	1,673.
	48"	79"	<b>R3B0PF179 48-()</b> ( )	1,498.	1,521.	1,562.	1,648.	1,707.	1,785.	1,834.
	60"	79"	<b>R3B0PF179 60-()</b> ( )	1,610.	1,657.	1,738.	1,910.	2,033.	2,187.	2,282.
	66"	79"	<b>R3B0PF179 66-()</b> ( )	1,645.	1,692.	1,773.	1,945.	2,068.	2,222.	2,317.
	72"	79"	<b>R3B0PF179 72-()</b> ( )	1,672.	1,719.	1,800.	1,972.	2,095.	2,249.	2,344.
Monolithic, fabric one side Beltway one side (fabric side) 	18"	79"	<b>R3B1PF179 18-()</b> ( )	1,299.	1,324.	1,374.	1,482.	1,548.	1,646.	1,712.
	20"	79"	<b>R3B1PF179 20-()</b> ( )	1,299.	1,324.	1,374.	1,482.	1,548.	1,646.	1,712.
	24"	79"	<b>R3B1PF179 24-()</b> ( )	1,388.	1,413.	1,463.	1,571.	1,637.	1,735.	1,801.
	30"	79"	<b>R3B1PF179 30-()</b> ( )	1,474.	1,499.	1,549.	1,657.	1,723.	1,821.	1,887.
	36"	79"	<b>R3B1PF179 36-()</b> ( )	1,827.	1,852.	1,902.	2,010.	2,076.	2,174.	2,240.
	42"	79"	<b>R3B1PF179 42-()</b> ( )	1,990.	2,015.	2,065.	2,173.	2,239.	2,337.	2,403.
	48"	79"	<b>R3B1PF179 48-()</b> ( )	2,080.	2,105.	2,155.	2,263.	2,329.	2,427.	2,493.

Order Code	Specification Information	Application Notes
Example: <b>R3B0PF17918-A4K</b>	<i>To order please specify pattern number including:</i>	<i>1. Top trim profile:</i>
<b>R3</b> Reff Generation 2	1. Top trim profile	A = Flat
<b>B0</b> No Beltway	2. Base height	B = Square
<b>P</b> Monolithic panel	3. Knockout option	C = Bullnose
<b>F1</b> Fabric one side, V1 other	(K = with knockouts, N = without knockouts)	E = Extruded Aluminum
<b>79</b> 79" high	4. Panel side 1 finish(s) inside	<i>2. Base height:</i>
<b>18</b> 18" wide	For panels with Beltway, please specify;	4 = 4" base height
<b>A</b> Flat style top trim profile	Side 1 - Below Belt	6 = 6" base height (add \$47 per panel for this option)
<b>4</b> 4" base height	Side 1 - Above Belt	Applicable finishes are listed on page 5 and 6.
<b>K</b> Include knockouts in base	5. Panel side 2 finish(s) outside	Product on this page can be attached to posts 79"H as well as panels 42", 49", 64" and 79"H. Panels on this page will not attach to panels made before April 1997 without an attachment kit from page 117.
<b>W281</b> Fabric - Side 1	6. Top trim finish	Remember to specify Beltway paint finish when applicable.
<b>Y328</b> Mahogany - side 2	i) Top trim profile A, B or C options:	79"H hookstrip reveal strips are ordered separately from page 117 at no charge.
<b>V316</b> Maple (top trim finish)	V1, V2, V3, P1, P2, P3 finishes	
<b>111</b> Jet Black (base finish)	ii) Top trim profile E options:	
<b>M</b> Optional milled frame	AA-anodized aluminum or P1, P2, P3 finish listed on page 5 excluding silver	
	7. Base finish	
	8. Beltway finish - only for panels with Beltway	
	9. <i>Optional non-beltway panels:</i> specify (M) for panel frame to be milled for ported components, \$14 list upcharge applicable	



# Monolithic panels 79" H

*fabric one side, conventional veneer other side*

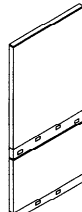
description	w	h	pattern no.	grade							
				10	15	20	30	35	40	45	
Monolithic, fabric one side	18"	79"	<b>R3B0PF279 18-()</b> ( )	\$915.	\$938.	\$979.	\$1,065.	\$1,124.	\$1,202.	\$1,251.	
Regular acoustics	20"	79"	<b>R3B0PF279 20-()</b> ( )	915.	938.	979.	1,065.	1,124.	1,202.	1,251.	
	24"	79"	<b>R3B0PF279 24-()</b> ( )	1,002.	1,025.	1,066.	1,152.	1,211.	1,289.	1,338.	
	30"	79"	<b>R3B0PF279 30-()</b> ( )	1,131.	1,154.	1,195.	1,281.	1,340.	1,418.	1,467.	
	36"	79"	<b>R3B0PF279 36-()</b> ( )	1,232.	1,255.	1,296.	1,382.	1,441.	1,519.	1,568.	
	42"	79"	<b>R3B0PF279 42-()</b> ( )	1,363.	1,386.	1,427.	1,513.	1,572.	1,650.	1,699.	
	48"	79"	<b>R3B0PF279 48-()</b> ( )	1,525.	1,548.	1,589.	1,675.	1,734.	1,812.	1,861.	
	60"	79"	<b>R3B0PF279 60-()</b> ( )	1,640.	1,687.	1,768.	1,940.	2,063.	2,217.	2,312.	
	66"	79"	<b>R3B0PF279 66-()</b> ( )	1,671.	1,718.	1,799.	1,971.	2,094.	2,248.	2,343.	
	72"	79"	<b>R3B0PF279 72-()</b> ( )	1,706.	1,753.	1,834.	2,006.	2,129.	2,283.	2,378.	
	Monolithic, fabric one side	18"	79"	<b>R3B1PF279 18-()</b> ( )	1,322.	1,347.	1,397.	1,505.	1,571.	1,669.	1,735.
	Beltway one side (fabric side)	20"	79"	<b>R3B1PF279 20-()</b> ( )	1,322.	1,347.	1,397.	1,505.	1,571.	1,669.	1,735.
	24"	79"	<b>R3B1PF279 24-()</b> ( )	1,413.	1,438.	1,488.	1,596.	1,662.	1,760.	1,826.	
	30"	79"	<b>R3B1PF279 30-()</b> ( )	1,499.	1,524.	1,574.	1,682.	1,748.	1,846.	1,912.	
	36"	79"	<b>R3B1PF279 36-()</b> ( )	1,857.	1,882.	1,932.	2,040.	2,106.	2,204.	2,270.	
	42"	79"	<b>R3B1PF279 42-()</b> ( )	2,026.	2,051.	2,101.	2,209.	2,275.	2,373.	2,439.	
	48"	79"	<b>R3B1PF279 48-()</b> ( )	2,118.	2,143.	2,193.	2,301.	2,367.	2,465.	2,531.	

Order Code	Specification Information	Application Notes
Example: <b>R3B0PF27918-A4K</b>	<i>To order please specify pattern number including:</i>	<i>1. Top trim profile:</i>
<b>R3</b> Reff Generation 3	1. Top trim profile	A = Flat
<b>B0</b> No Beltway	2. Base height	B = Square
<b>P</b> Monolithic panel	3. Knockout option	C = Bullnose
<b>F2</b> Fabric one side, V2 other	(K = with knockouts, N = without knockouts)	E = Extruded Aluminum
<b>79</b> 79" high	4. Panel side 1 finish(s) inside	<i>2. Base height:</i>
<b>18</b> 18" wide	For panels with Beltway, please specify;	4 = 4" base height
<b>A</b> Flat style top trim profile	Side 1 = Below Belt	6 = 6" base height (add \$47 per panel for this option)
<b>4</b> 4" base height	Side 1 = Above Belt	Applicable finishes are listed on page 5 and 6.
<b>K</b> Include knockouts in base	5. Panel side 2 finish(s) outside	
<b>W281</b> Fabric - Side 1	6. Top trim finish	
<b>V316</b> Maple surface - side 2	i)Top trim profile A,B or C options:	
<b>V316</b> Maple (top trim finish)	V1, V2, V3, P1, P2, P3 finishes	
<b>111</b> Jet Black (base finish)	ii)Top trim profile E options:	
<b>M</b> Optional milled frame	AA-anodized aluminum or P1, P2, P3 finish listed on page 5 excluding silver	
	7. Base finish	
	8. Beltway finish - only for panels with Beltway	
	9. <i>Optional non-beltway panels:</i> specify (M) for panel frame to be milled for ported components, \$14 list upcharge applicable	
		The panels on this page are not designed to be stacked upon.
		Fabric and veneer covers of 60", 66" and 72" wide panels are two pieces, split vertically.
		6" Raceway option increases panel height by 2 3/4".
		Product on this page can be attached to posts 79"H as well as panels 42", 49", 64" and 79"H. Panels on this page will not attach to panels made before April 1997 without an attachment kit from page 117.
		Remember to specify Beltway paint finish when applicable.
		79"H hookstrip reveal strips are ordered separately from page 117 at no charge.

# Monolithic panels 79" H

*fabric one side, exotic veneer other side*

description	w	h	pattern no.	grade						
				10	15	20	30	35	40	45
Monolithic, fabric one side Regular acoustics 	18"	79"	<b>R3B0PF379 18-()</b> ( )	\$1,205.	\$1,228.	\$1,269.	\$1,355.	\$1,414.	\$1,492.	\$1,541.
	20"	79"	<b>R3B0PF379 20-()</b> ( )	1,205.	1,228.	1,269.	1,355.	1,414.	1,492.	1,541.
	24"	79"	<b>R3B0PF379 24-()</b> ( )	1,326.	1,349.	1,390.	1,476.	1,535.	1,613.	1,662.
	30"	79"	<b>R3B0PF379 30-()</b> ( )	1,498.	1,521.	1,562.	1,648.	1,707.	1,785.	1,834.
	36"	79"	<b>R3B0PF379 36-()</b> ( )	1,637.	1,660.	1,701.	1,787.	1,846.	1,924.	1,973.
	42"	79"	<b>R3B0PF379 42-()</b> ( )	1,812.	1,835.	1,876.	1,962.	2,021.	2,099.	2,148.
	48"	79"	<b>R3B0PF379 48-()</b> ( )	2,033.	2,056.	2,097.	2,183.	2,242.	2,320.	2,369.
	60"	79"	<b>R3B0PF379 60-()</b> ( )*	2,156.	2,203.	2,284.	2,456.	2,579.	2,733.	2,828.
	66"	79"	<b>R3B0PF379 66-()</b> ( )*	2,200.	2,247.	2,328.	2,500.	2,623.	2,777.	2,872.
	72"	79"	<b>R3B0PF379 72-()</b> ( )*	2,247.	2,294.	2,375.	2,547.	2,670.	2,824.	2,919.

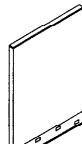
Monolithic, fabric one side Beltway fabric side 	18"	79"	<b>R3B1PF379 18-()</b> ( )	1,742.	1,767.	1,817.	1,925.	1,991.	2,089.	2,155.
	20"	79"	<b>R3B1PF379 20-()</b> ( )	1,742.	1,767.	1,817.	1,925.	1,991.	2,089.	2,155.
	24"	79"	<b>R3B1PF379 24-()</b> ( )	1,865.	1,890.	1,940.	2,048.	2,114.	2,212.	2,278.
	30"	79"	<b>R3B1PF379 30-()</b> ( )	1,980.	2,005.	2,055.	2,163.	2,229.	2,327.	2,393.
	36"	79"	<b>R3B1PF379 36-()</b> ( )	2,463.	2,488.	2,538.	2,646.	2,712.	2,810.	2,876.
	42"	79"	<b>R3B1PF379 42-()</b> ( )	2,690.	2,715.	2,765.	2,873.	2,939.	3,037.	3,103.
	48"	79"	<b>R3B1PF379 48-()</b> ( )	2,817.	2,842.	2,892.	3,000.	3,066.	3,164.	3,230.

Order Code	Specification Information	Application Notes
Example: <b>R3B0PF37918-A4K</b> <b>R3</b> Reff Generation 3 <b>B0</b> No Beltway <b>P</b> Monolithic panel <b>F3</b> Fabric one side, V3 other <b>79</b> 79" high <b>18</b> 18" wide <b>A</b> Flat style top trim profile <b>4</b> 4" base height <b>K</b> Include knockouts in base <b>W281</b> Fabric - Side 1 <b>V512</b> Figured Anigre surface - side 2 <b>V512</b> Figured Anigre (top trim finish) <b>111</b> Jet Black (base finish) <b>M</b> Optional milled frame	To order please specify pattern number including: 1. Top trim profile 2. Base height 3. Knockout option (K = with knockouts, N = without knockouts) 4. Panel side 1 finish(s) inside For panels with Beltway, please specify; Side 1 - Below Belt Side 1 - Above Belt 5. Panel side 2 finish(s) outside 6. Top trim finish i) Top trim profile A, B or C options: V1, V2, V3, P1, P2, P3 finishes ii) Top trim profile E options: AA-anodized aluminum or P1, P2, P3 finish listed on page 5 excluding silver 7. Base finish 8. Beltway finish - only for panels with Beltway 9. <i>Optional non-beltway panels:</i> specify (M) for panel frame to be milled for ported components, \$14 list upcharge applicable	1. <i>Top trim profile:</i> A = Flat B = Square C = Bullnose E = Extruded Aluminum 2. <i>Base height:</i> 4 = 4" base height 6 = 6" base height (add \$47 per panel for this option) Applicable finishes are listed on page 5 and 6. The panels on this page are not designed to be stacked upon. Fabric and veneer covers of 60", 66" and 72" wide panels are two pieces, split vertically. 6" Raceway option increases panel height by 2 3/4". Product on this page can be attached to posts 79"H as well as panels 42", 49", 64" and 79"H. Panels on this page will not attach to panels made before April 1997 without an attachment kit from page 117. Remember to specify Beltway paint finish when applicable. 79"H hookstrip reveal strips are ordered separately from page 117 at no charge.

# Monolithic panels 79" H

## Laminate/Laminate

description	w	h	pattern no.	L
Monolithic, laminate both sides with raceway both sides	18"	79"	<b>R3B0PLL7918( )()</b>	\$883.
	20"	79"	<b>R3B0PLL7920( )()</b>	883.
	24"	79"	<b>R3B0PLL7924( )()</b>	962.
	30"	79"	<b>R3B0PLL7930( )()</b>	1,077.
	36"	79"	<b>R3B0PLL7936( )()</b>	1,164.
	42"	79"	<b>R3B0PLL7942( )()</b>	1,280.
	48"	79"	<b>R3B0PLL7948( )()</b>	1,434.
	60"	79"	<b>R3B0PLL7960( )()*</b>	1,548.
	66"	79"	<b>R3B0PLL7966( )()*</b>	1,594.
	72"	79"	<b>R3B0PLL7972( )()*</b>	1,642.

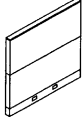

Order Code	Specification Information	Application Notes
Example: <b>R3B0PLL7918-A4K</b>	<i>To order please specify pattern number including:</i>	
<b>R3</b> Reff Generation 3	1. Top trim profile	1. <i>Top trim profile:</i> A = Flat B = Square C = Bullnose E = Extruded Aluminum
<b>B0</b> No Beltway	2. Base height	2. <i>Base height:</i> 4 = 4" base height
<b>P</b> Monolithic panel	3. Knockout option (K = with knockouts, N = without knockouts)	Applicable finishes are listed on page 5 and 6.
<b>LL</b> Laminate both sides	4. Panel side 1 inside	Product on this page will accept wood grain laminate where laminate is currently an option.
<b>79</b> 79" high	5. Panel side 2 outside	Panel product is subject to a 10% upcharge on the base panel price. Refer to panel product upcharge table.
<b>18</b> 18" wide	6. Top trim finish i) Top trim profile A,B or C options: V1, V2, V3, P1, P2, P3 finishes ii) Top trim profile E options: AA-anodized aluminum or P1, P2, P3 finish listed on page 5 excluding silver	The panels on this page are not designed to be stacked upon.
<b>A</b> Flat style top trim profile	7. Base finish	Fabric and veneer covers of 60", 66" and 72" wide panels are two pieces, split vertically.
<b>4</b> 4" base height	8. <i>Optional non-beltway panels:</i> specify (M) for panel frame to be milled for ported components, \$14 list upcharge applicable	6" Raceway option increases panel height by 2 3/4".
<b>K</b> Include knockouts in base		Product on this page can be attached to posts 79"H as well as panels 42", 49", 64" and 79"H. Panels on this page will not attach to panels made before April 1997 without an attachment kit from page 117.
<b>118</b> Laminate - side 1		Remember to specify Beltway paint finish when applicable.
<b>118</b> Laminate - side 2		79"H hookstrip reveal strips are ordered separately from page 117 at no charge.
<b>V512</b> Figured Anigre (top trim finish)		
<b>111</b> Jet Black (base finish)		
<b>M</b> Optional milled frame		

# Tiled panels 34" H *fabric*

description	w	h	pattern no.	grade						
				10	15	20	30	35	40	45
Tiled, fabric both sides	18"	34"	<b>R3B0TFF34 18-( ) ( )</b>	\$577.	\$605.	\$665.	\$729.	\$785.	\$869.	\$921.
Regular acoustics	20"	34"	<b>R3B0TFF34 20-( ) ( )</b>	577.	605.	665.	729.	785.	869.	921.
	24"	34"	<b>R3B0TFF34 24-( ) ( )</b>	623.	651.	711.	775.	830.	915.	967.
	30"	34"	<b>R3B0TFF34 30-( ) ( )</b>	666.	694.	754.	818.	874.	958.	1,010.
	36"	34"	<b>R3B0TFF34 36-( ) ( )</b>	709.	737.	797.	861.	917.	1,001.	1,053.
	42"	34"	<b>R3B0TFF34 42-( ) ( )</b>	815.	843.	903.	967.	1,023.	1,107.	1,159.
	48"	34"	<b>R3B0TFF34 48-( ) ( )</b>	847.	875.	935.	999.	1,055.	1,139.	1,191.

Order Code	Specification Information	Application Notes
Example: <b>R3B0TFF3418-A4K</b>	<i>To order please specify pattern number including:</i>	
<b>R3</b> Reff Generation 3	2. Base height: 4 = 4" base height 6 = 6" base height (add \$47 per panel)	All panels on this page have no high acoustical option or Beltway option. Product on this page can be attached to posts 34"H, other 34", 42", 49", 64", and 79" panels without beltway. To attach 34" high panels to Beltway posts, order appropriate attachment kits from page 117.
<b>B0</b> No Beltway	1. Top trim profile	
<b>T</b> Tiled panel	2. Base height	All panels on this page accept stacking modules.  6" Raceway option increases panel height by 2 3/4".
<b>FF</b> Fabric on both sides	3. Knockout option (K = with knockouts, N = without knockouts)	
<b>34</b> 34" high	4. Panel side 1A	Applicable finishes are listed on page 5 and 6.
<b>18</b> 18" wide	5. Panel side 1B	
<b>A</b> Flat style top trim profile	6. Panel side 2A	The panels on this page will accept stacking modules to increase their height on 18" to 48"W panels only. The 60" to 72"W panels will not accept stacking modules on top of themselves.
<b>4</b> 4" base height	7. Panel side 2B	
<b>K</b> Include knockouts in base	8. Top trim finish	79"H hookstrip reveal strips are ordered separately from page 117 at no charge.
<b>W281</b> Fabric - Side 1A	i) Top trim profile A,B or C options: V1, V2, V3, P1, P2, P3 finishes	
<b>W281</b> Fabric - Side 1B	ii) Top trim profile E options: AA-anodized aluminum or P1, P2, P3 finish listed on page 5 excluding silver	Ported panel components to be installed below worksurface if panel 34"h.
<b>W281</b> Fabric - Side 2A	9. Base finish	
<b>W281</b> Fabric - Side 2B	10. <i>Optional:</i> specify (M) for panel frame to be milled for ported components. \$14 list upcharge applicable	
<b>V316</b> Maple (top trim finish)		
<b>111</b> Jet Black (base finish)		
<b>M</b> Optional milled frame		
	<i>1. Top trim profile:</i> A = Flat B = Square C = Bullnose E = Extruded Aluminum	

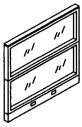
# Tiled panels 34" H glass

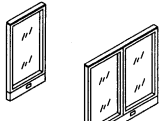
description	w	h	pattern no.	clear tempered glass	architectural tempered glass	add for P2 finish	add for P3 finish	add for AA finish
Tiled, two 15" high glass sections without center mullion (type A) 	18"	34"	<b>R2B0TWA34 18-</b> ( ) ( )	\$903.	\$1,074.	\$36.	\$72.	\$90.
	20"	34"	<b>R2B0TWA34 20-</b> ( ) ( )	903.	1,074.	36.	72.	90.
	24"	34"	<b>R2B0TWA34 24-</b> ( ) ( )	945.	1,149.	36.	72.	95.
	30"	34"	<b>R2B0TWA34 30-</b> ( ) ( )	1,096.	1,349.	36.	72.	109.
	36"	34"	<b>R2B0TWA34 36-</b> ( ) ( )	1,137.	1,440.	36.	72.	111.
	42"	34"	<b>R2B0TWA34 42-</b> ( ) ( )	1,193.	1,553.	36.	72.	117.
	48"	34"	<b>R2B0TWA34 48-</b> ( ) ( )	1,236.	1,646.	36.	72.	122.
Tiled, two 15" high glass sections with center mullion (type B) 	30"	34"	<b>R2B0TWB34 30-</b> ( ) ( )	1,312.	1,567.	36.	72.	131.
	36"	34"	<b>R2B0TWB34 36-</b> ( ) ( )	1,366.	1,673.	36.	72.	135.
	42"	34"	<b>R2B0TWB34 42-</b> ( ) ( )	1,431.	1,786.	36.	72.	140.
	48"	34"	<b>R2B0TWB34 48-</b> ( ) ( )	1,484.	1,899.	36.	72.	146.
Tiled, one 30" high glass section without center mullion on sizes 18, 20 and 24 but with center mullion on sizes 30, 36, 42, and 48 Type C 	18"	34"	<b>R2B0TWC34 18-</b> ( ) ( )	712.	928.	28.	58.	109.
	20"	34"	<b>R2B0TWC34 20-</b> ( ) ( )	712.	928.	28.	58.	109.
	24"	34"	<b>R2B0TWC34 24-</b> ( ) ( )	750.	978.	28.	58.	117.
	30"	34"	<b>R2B0TWC34 30-</b> ( ) ( )	926.	1,204.	36.	72.	148.
	36"	34"	<b>R2B0TWC34 36-</b> ( ) ( )	1,031.	1,338.	36.	72.	166.
	42"	34"	<b>R2B0TWC34 42-</b> ( ) ( )	1,090.	1,416.	36.	72.	181.
	48"	34"	<b>R2B0TWC34 48-</b> ( ) ( )	1,143.	1,489.	36.	72.	189.

## Order Code

Example:	<b>R2B0TWA3418-A4K</b>
<b>R2</b>	Reff Generation 2
<b>B0</b>	No Beltway
<b>T</b>	Tiled panel
<b>WA</b>	Window, type A
<b>34</b>	34" high
<b>18</b>	18" wide
<b>A</b>	Flat style top trim profile
<b>4</b>	4" base height
<b>K</b>	Include knockouts in base
<b>111</b>	Tile Divider
<b>V316</b>	Maple (top trim finish)
<b>111</b>	Jet Black (base finish)
<b>111</b>	Jet Black (window frame finish)
<b>GL13</b>	Glass option

## Specification Information

- To order please specify pattern number including:*
1. Top trim profile
  2. Base height
  3. Knockout option (K = with knockouts, N = without knockouts)
  4. Divider option (applicable R2B0TWA and R2B0TWB)  
B = black steel divider or specify AA-anodized aluminum or painted option excluding silver from page 5 for extruded aluminum divider (black reveal interior side, upcharge applicable for extruded aluminum)
  5. Top trim finish  
i) Top trim profile A, B or C options:  
V1, V2, V3, P1, P2, P3 finishes  
ii) Top trim profile E options:  
AA-anodized aluminum or P1, P2, P3 painted finish from page 5 excluding silver
  6. Base finish
  7. Window frame finish (Painted or Anodized aluminum finishes)  
*If AA finish (anodized) upcharge applicable as noted in AA price column*
  8. Glass type

## Application Notes

1. *Top trim profile:*  
A = Flat  
B = Square  
C = Bullnose  
E = Extruded Aluminum
  2. *Base height:*  
4 = 4" base height  
6 = 6" base height (add \$47 per panel)
  4. *Extruded aluminum tile divider:*  
Add for:  
\$14 for 18w and 20w  
\$15 for 24w and 30w  
\$16 for 36w and 42w  
\$22 for 48w
  3. *Glass type*  
Temp = Cleared tempered glass  
*Architectural options:*  
GL13 = Powder glass  
GL6 = Block matrix glass  
GL8 = Wafer glass
- All panels on this page accept stacking modules.
- 6" Raceway option increases panel height by 2 3/4".
- Applicable finishes are listed on page 5 and 6.
- All panels on this page have no high acoustical option or Beltway option. Product on this page can be attached to posts 34"H, other 34", 42", 49", 64", and 79" panels without beltway. To attach 34" high panels to Beltway posts, order appropriate attachment kits from page 117.
- The panels on this page will accept stacking modules to increase their height on 18" to 48"W panels only. The 60" to 72"W panels will not accept stacking modules on top of themselves.
- Panel glass is mounted flush to one side of the window panel. All window panels incorporate tempered glass 3/16" thick. 30" High window panels that are 30" or wider incorporate a center mullion.
- 79"H hookstrip reveal strips are ordered separately from page 117 at no charge.

# Tiled panels 34" H

*fabric one side, laminate or techwood opposite side*

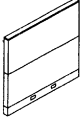
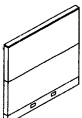
description	w	h	pattern no.	grade						
				10	15	20	30	35	40	45
Tiled, fabric one side laminate other; Regular acoustics 	18"	34"	<b>R3B0TFL34 18-()</b> ( )	\$628.	\$642.	\$670.	\$702.	\$730.	\$768.	\$794.
	20"	34"	<b>R3B0TFL34 20-()</b> ( )	628.	642.	670.	702.	730.	768.	794.
	24"	34"	<b>R3B0TFL34 24-()</b> ( )	668.	682.	710.	742.	770.	808.	834.
	30"	34"	<b>R3B0TFL34 30-()</b> ( )	711.	725.	753.	785.	813.	851.	877.
	36"	34"	<b>R3B0TFL34 36-()</b> ( )	752.	766.	794.	826.	854.	892.	918.
	42"	34"	<b>R3B0TFL34 42-()</b> ( )	856.	870.	898.	930.	958.	996.	1,022.
	48"	34"	<b>R3B0TFL34 48-()</b> ( )	885.	899.	927.	959.	987.	1,025.	1,051.
Tiled, fabric one side techwood other; Regular acoustics 	18"	34"	<b>R3B0TF134 18-()</b> ( )	674.	688.	720.	752.	780.	822.	848.
	20"	34"	<b>R3B0TF134 20-()</b> ( )	674.	688.	720.	752.	780.	822.	848.
	24"	34"	<b>R3B0TF134 24-()</b> ( )	719.	733.	765.	797.	825.	867.	893.
	30"	34"	<b>R3B0TF134 30-()</b> ( )	766.	780.	812.	844.	872.	914.	940.
	36"	34"	<b>R3B0TF134 36-()</b> ( )	808.	822.	854.	886.	914.	956.	982.
	42"	34"	<b>R3B0TF134 42-()</b> ( )	923.	937.	969.	1,001.	1,029.	1,071.	1,097.
	48"	34"	<b>R3B0TF134 48-()</b> ( )	952.	966.	998.	1,030.	1,058.	1,100.	1,126.

Order Code	Specification Information	Application Notes
Example: <b>R3B0TFL3418-A4K</b> <b>R3</b> Reff Generation 3 <b>B0</b> No Beltway <b>T</b> Tiled panel <b>FL</b> Fabric one side, laminate other <b>34</b> 34" high <b>18</b> 18" wide <b>A</b> Flat style top trim profile <b>4</b> 4" base height <b>K</b> Include knockouts in base <b>B</b> Tile divider, black <b>W281</b> Fabric - Side 1A <b>W281</b> Fabric - Side 1B <b>114</b> Folkstone grey - side 2A <b>114</b> Folkstone grey - side 2B <b>V316</b> Maple (top trim finish) <b>111</b> Jet Black (base finish) <b>M</b> Optional milled frame	To order please specify pattern number including: 1. Top trim profile 2. Base height 3. Knockout option (K = with knockouts, N = without knockouts) 4. Tile divider B = black steel divider or specify AA-anodized aluminum or painted option excluding silver from page 5 for extruded aluminum divider (upcharge applicable for extruded aluminum divider) 5. Fabric side, finish (specify selection per insert) i) tile 1A bottom ii) tile 1B top 6. Hard side, finish If laminate: i) tile 2A bottom ii) tile 2B top If V1, V2 or V3 specify wood finish, one finish per side (not per insert) 7. Top trim finish i) Profile A, B or C options: V1, V2, V3, P1, P2, P3 finishes ii) Profile E options: AA-anodized aluminum or P1, P2, P3 painted finishes from page 5 excluding silver	8. Base finish 9. <i>Optional non-beltway panels:</i> specify (M) for panel frame to be milled for ported components, \$14 list upcharge applicable  1. <i>Top trim profile:</i> A = Flat B = Square C = Bullnose E = Extruded Aluminum  2. <i>Base height:</i> 4 = 4" base height 6 = 6" base height (add \$47 per panel)  4. <i>Extruded aluminum tile divider: Optional for non fabric side only</i> (fabric side always black) 34" h add per panel: \$14 for 18w and 20w \$15 for 24w and 30w \$16 for 36w and 42w \$22 for 48w  Applicable finishes are listed on page 5 and 6.  Product on this page will accept wood grain laminate where laminate is currently an option. Panel product is subject to a 10% upcharge on the base panel price. Refer to panel product upcharge table.
		All panels on this page accept stacking modules.  6" Raceway option increases panel height by 2 <sup>3</sup> / <sub>4</sub> ".  All panels on this page have no high acoustical option or Beltway option.  Product on this page can be attached to posts 34"H and higher as well as 34", 42", 49", 64", and 79" panels. To attach 34" Beltway panels to posts order appropriate attachment kit from page 117.  79"H hookstrip reveal strips are ordered separately from page 117 at no charge.  Ported panel components to be installed below worksurface if panel 34" h.

# Tiled panels 34" H

*fabric one side, conventional or exotic opposite side*

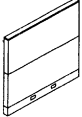
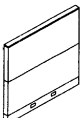
description	w	h	pattern no.	grade						
				10	15	20	30	35	40	45
Tiled, fabric one side conventional other; Regular acoustics 	18"	34"	<b>R3B0TF234 18-()</b> ( )	\$687.	\$701.	\$733.	\$765.	\$793.	\$835.	\$861.
	20"	34"	<b>R3B0TF234 20-()</b> ( )	687.	701.	733.	765.	793.	835.	861.
	24"	34"	<b>R3B0TF234 24-()</b> ( )	732.	746.	778.	810.	838.	880.	906.
	30"	34"	<b>R3B0TF234 30-()</b> ( )	779.	793.	825.	857.	885.	927.	953.
	36"	34"	<b>R3B0TF234 36-()</b> ( )	822.	836.	868.	900.	928.	970.	996.
	42"	34"	<b>R3B0TF234 42-()</b> ( )	937.	951.	983.	1,015.	1,043.	1,085.	1,111.
	48"	34"	<b>R3B0TF234 48-()</b> ( )	970.	984.	1,016.	1,048.	1,076.	1,118.	1,144.
Tiled, fabric one side, exotic other Regular acoustics 	18"	34"	<b>R3B0TF334 18-()</b> ( )	918.	932.	964.	996.	1,024.	1,066.	1,092.
	20"	34"	<b>R3B0TF334 20-()</b> ( )	918.	932.	964.	996.	1,024.	1,066.	1,092.
	24"	34"	<b>R3B0TF334 24-()</b> ( )	978.	992.	1,024.	1,056.	1,084.	1,126.	1,152.
	30"	34"	<b>R3B0TF334 30-()</b> ( )	1,040.	1,054.	1,086.	1,118.	1,146.	1,188.	1,214.
	36"	34"	<b>R3B0TF334 36-()</b> ( )	1,099.	1,113.	1,145.	1,177.	1,205.	1,247.	1,273.
	42"	34"	<b>R3B0TF334 42-()</b> ( )	1,255.	1,269.	1,301.	1,333.	1,361.	1,403.	1,429.
	48"	34"	<b>R3B0TF334 48-()</b> ( )	1,298.	1,312.	1,344.	1,376.	1,404.	1,446.	1,472.

Order Code	Specification Information	Application Notes
Example: <b>R3B0TF23418-A4K</b>	<i>To order please specify pattern number including:</i>	All panels on this page accept stacking modules.
<b>R3</b> Reff Generation 3	1. Top trim profile	6" Raceway option increases panel height by 2 3/4".
<b>B0</b> No Beltway	2. Base height	All panels on this page have no high acoustical option or Beltway option.
<b>T</b> Tiled panel	3. Knockout option (K = with knockouts, N = without knockouts)	Product on this page can be attached to posts 34"H and higher as well as 34", 42", 49", 64", and 79" panels. To attach 34" Beltway panels to posts order appropriate attachment kit from page 117.
<b>F2</b> Fabric one side, conventional other	4. Tile divider B = black steel divider or specify AA-anodized aluminum or painted option excluding silver from page 5 for extruded aluminum divider (upcharge applicable for extruded aluminum divider)	79"H hookstrip reveal strips are ordered separately from page 117 at no charge.
<b>34</b> 34" high	5. Fabric side, finish (specify selection per insert) i) tile 1A bottom ii) tile 1B top	Ported panel components to be installed below worksurface if panel 34" h.
<b>18</b> 18" wide	6. Hard side, finish If laminate: i) tile 2A bottom ii) tile 2B top If V1, V2 or V3 specify wood finish, one finish per side (not per insert)	
<b>A</b> Flat style top trim profile	7. Top trim finish i) Profile A, B or C options: V1, V2, V3, P1, P2, P3 finishes ii) Profile E options: AA-anodized aluminum or P1, P2, P3 painted finishes from page 5 excluding silver	
<b>4</b> 4" base height		
<b>K</b> Include knockouts in base		
<b>B</b> Tile divider, black		
<b>W281</b> Fabric - Side 1A		
<b>W281</b> Fabric - Side 1B		
<b>114</b> Folkstone grey - side 2A		
<b>114</b> Folkstone grey - side 2B		
<b>V316</b> Maple (top trim finish)		
<b>111</b> Jet Black (base finish)		
<b>M</b> Optional milled frame		
	8. Base finish	
	9. <i>Optional non-beltway panels:</i> specify (M) for panel frame to be milled for ported components, \$14 list upcharge applicable	
	1. <i>Top trim profile:</i> A = Flat B = Square C = Bullnose E = Extruded Aluminum	
	2. <i>Base height:</i> 4 = 4" base height 6 = 6" base height (add \$47 per panel)	
	4. <i>Extruded aluminum tile divider: Optional for non fabric side only</i> (fabric side always black) 34"h add per panel: \$14 for 18w and 20w \$15 for 24w and 30w \$16 for 36w and 42w \$22 for 48w	
	Applicable finishes are listed on page 5 and 6.	
	Product on this page will accept wood grain laminate where laminate is currently an option. Panel product is subject to a 10% upcharge on the base panel price. Refer to panel product upcharge table.	

# Tiled panels 34" H

## Laminate/Laminate

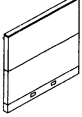
description	w	h	pattern no.	L
Tiled, laminate both sides with raceway both sides 	18"	34"	<b>R3B0TLL3418</b> ( ) ( )	\$710.
	20"	34"	<b>R3B0TLL3420</b> ( ) ( )	710.
	24"	34"	<b>R3B0TLL3424</b> ( ) ( )	773.
	30"	34"	<b>R3B0TLL3430</b> ( ) ( )	866.
	36"	34"	<b>R3B0TLL3436</b> ( ) ( )	936.
	42"	34"	<b>R3B0TLL3442</b> ( ) ( )	964.
	48"	34"	<b>R3B0TLL3448</b> ( ) ( )	993.

Example: **R3B0TLL3418-A4K**

<b>R3</b>	Reff Generation 3
<b>B0</b>	No Beltway
<b>T</b>	Tiled panel
<b>LL</b>	Laminate both sides
<b>34</b>	34" high
<b>18</b>	18" wide
<b>A</b>	Flat style top trim profile
<b>4</b>	4" base height
<b>K</b>	Include knockouts in base
<b>B</b>	Tile divider, black
<b>118</b>	Laminate - side 1A
<b>118</b>	Laminate - side 1B
<b>118</b>	Laminate - side 2A
<b>118</b>	Laminate - side 2B
<b>V316</b>	Maple (top trim finish)
<b>111</b>	Jet Black (base finish)
<b>M</b>	Optional milled frame

To order please specify pattern number including:

1. Top trim profile
2. Base height
3. Knockout option  
(K = with knockouts, N = without knockouts)
4. Tile divider  
B = black steel divider or specify AA-anodized aluminum or painted option excluding silver from page 5 for extruded aluminum divider (upcharge applicable for extruded aluminum divider)
5. Laminate, finish (specify selection per insert)  
i) tile 1A bottom  
ii) tile 1B top
6. Hard side, finish  
If laminate:  
i) tile 2A bottom  
ii) tile 2B top  
If V1, V2 or V3 specify wood finish, one finish per side (not per insert)
7. Top trim finish  
i) Profile A, B or C options:  
V1, V2, V3, P1, P2, P3 finishes  
ii) Profile E options:  
AA-anodized aluminum or P1, P2, P3 painted finishes from page 5 excluding silver

8. Base finish
9. *Optional non-beltway panels:*  
specify (M) for panel frame to be milled for ported components, \$14 list upcharge applicable

1. *Top trim profile:*  
A = Flat  
B = Square  
C = Bullnose  
E = Extruded Aluminum

2. *Base height:*  
4 = 4" base height

4. *Extruded aluminum tile divider:*  
**Optional for non fabric side only**  
(fabric side always black)  
34" h add per panel:  
\$14 for 18w and 20w  
\$15 for 24w and 30w  
\$16 for 36w and 42w  
\$22 for 48w

Applicable finishes are listed on page 5 and 6.

Product on this page will accept wood grain laminate where laminate is currently an option.  
Panel product is subject to a 10% upcharge on the base panel price. Refer to panel product upcharge table.

All panels on this page accept stacking modules.

All panels on this page have no high acoustical option or Beltway option.

Product on this page can be attached to posts 34"H and higher as well as 34", 42", 49", 64", and 79" panels. To attach 34" Beltway panels to posts order appropriate attachment kit from page 117.

79"H hookstrip reveal strips are ordered separately from page 117 at no charge.

Ported panel components to be installed below worksurface if panel 34" h.

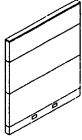

# Tiled panels 42" H fabric both sides

description	w	h	pattern no.	grade						
				10	15	20	30	35	40	45
Tiled, fabric both sides Regular acoustics 	18"	42"	<b>R3B0TFF42 18-( )()</b>	\$645.	\$679.	\$755.	\$853.	\$923.	\$1,025.	\$1,095.
	20"	42"	<b>R3B0TFF42 20-( )()</b>	645.	679.	755.	853.	923.	1,025.	1,095.
	24"	42"	<b>R3B0TFF42 24-( )()</b>	693.	727.	805.	901.	971.	1,073.	1,143.
	30"	42"	<b>R3B0TFF42 30-( )()</b>	742.	776.	854.	950.	1,020.	1,122.	1,192.
	36"	42"	<b>R3B0TFF42 36-( )()</b>	790.	824.	902.	998.	1,068.	1,170.	1,240.
	42"	42"	<b>R3B0TFF42 42-( )()</b>	893.	927.	1,005.	1,101.	1,171.	1,273.	1,343.
	48"	42"	<b>R3B0TFF42 48-( )()</b>	938.	972.	1,050.	1,146.	1,216.	1,318.	1,388.

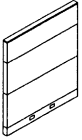
Tiled, fabric both sides High acoustics 	18"	42"	<b>R3B0TAA42 18-( )()</b>	706.	740.	818.	914.	984.	1,086.	1,156.
	20"	42"	<b>R3B0TAA42 20-( )()</b>	706.	740.	818.	914.	984.	1,086.	1,156.
	24"	42"	<b>R3B0TAA42 24-( )()</b>	760.	794.	872.	968.	1,038.	1,140.	1,210.
	30"	42"	<b>R3B0TAA42 30-( )()</b>	817.	851.	929.	1,025.	1,095.	1,197.	1,267.
	36"	42"	<b>R3B0TAA42 36-( )()</b>	870.	904.	982.	1,078.	1,148.	1,250.	1,320.
	42"	42"	<b>R3B0TAA42 42-( )()</b>	985.	1,019.	1,097.	1,193.	1,263.	1,365.	1,435.
	48"	42"	<b>R3B0TAA42 48-( )()</b>	1,037.	1,071.	1,149.	1,245.	1,315.	1,417.	1,487.

Order Code	Specification Information
Example: <b>R3B0TFF4218-A4K</b>	
<b>R3</b>	Reff Generation 3
<b>B0</b>	No Beltway
<b>T</b>	Tiled panel
<b>FF</b>	Fabric on both sides
<b>42</b>	42" high
<b>18</b>	18" wide
<b>A</b>	Flat style top trim profile
<b>4</b>	4" base height
<b>K</b>	Include knockouts in base
<b>W281</b>	Fabric - Side 1A
<b>W281</b>	Fabric - Side 1B
<b>W281</b>	Fabric - Side 1C
<b>W281</b>	Fabric - Side 2A
<b>W281</b>	Fabric - Side 2B
<b>W281</b>	Fabric - Side 2C
<b>V316</b>	Maple (top trim finish)
<b>111</b>	Jet Black (base finish)
<b>M</b>	Optional milled frame

**Specification Information**

To order please specify pattern number including:

1. Top trim profile
2. Base height
3. Knockout option  
(K = with knockouts, N = without knockouts)
4. Fabric side, finish (specify selection per insert)  
i) tile 1A bottom  
ii) tile 1B middle  
iii) tile 1C top
5. Fabric side, finish (specify selection per insert)  
i) tile 2A bottom  
ii) tile 2B middle  
iii) tile 2C top
6. Top trim finish  
i) Top trim profile A,B or C options:  
V1, V2, V3, P1, P2, P3 finishes  
ii) Top trim profile E options:  
AA-anodized aluminum or P1, P2, P3 finish listed on page 5 excluding silver
7. Base finish
8. Beltway finish
9. *Optional non-beltway panels:* specify (M) for panel frame to be milled for ported components, \$14 list upcharge applicable

**Application Notes**

1. *Top trim profile:*  
A = Flat  
B = Square  
C = Bullnose  
E = Extruded Aluminum

2. *Base height:*  
4 = 4" base height  
6 = 6" base height (add \$47 per panel for this option)

Note: Extruded aluminum reveal/tile dividers not optional for between fabric inserts.

Applicable finishes are listed on page 5 and 6.

The Reff System does not support the stacking of modules onto 42"H panels. These panels can be used to achieve transaction top height (see transaction tops page).

6" Raceway option increases panel height by 2<sup>3</sup>/<sub>4</sub>".

Product on this page can be attached to posts 42", 49", 64", and 79"H as well as panels 42", 49", 64" and 79"H. Panels on this page will not attach to panels made before April 1997 without an attachment kit from page 117.

Remember to specify Beltway paint finish when applicable.

79"H hookstrip reveal strips are ordered separately from page 117 at no charge.

# Tiled panels 42" H

*fabric both sides with Beltway*

description	w	h	pattern no.	grade						
				10	15	20	30	35	40	45
Tiled, fabric both sides Beltway one side 	18"	42"	<b>R3B1TFF42 18-( )()</b>	\$1,159.	\$1,193.	\$1,268.	\$1,367.	\$1,437.	\$1,539.	\$1,609.
	20"	42"	<b>R3B1TFF42 20-( )()</b>	1,159.	1,193.	1,268.	1,367.	1,437.	1,539.	1,609.
	24"	42"	<b>R3B1TFF42 24-( )()</b>	1,185.	1,219.	1,294.	1,393.	1,463.	1,565.	1,635.
	30"	42"	<b>R3B1TFF42 30-( )()</b>	1,247.	1,281.	1,356.	1,455.	1,525.	1,627.	1,697.
	36"	42"	<b>R3B1TFF42 36-( )()</b>	1,472.	1,506.	1,581.	1,680.	1,750.	1,852.	1,922.
	42"	42"	<b>R3B1TFF42 42-( )()</b>	1,590.	1,624.	1,699.	1,798.	1,868.	1,970.	2,040.
	48"	42"	<b>R3B1TFF42 48-( )()</b>	1,645.	1,679.	1,754.	1,853.	1,923.	2,025.	2,095.

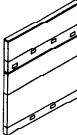
Tiled, fabric both sides Beltway two sides 	18"	42"	<b>R3B2TFF42 18-( )()</b>	1,181.	1,215.	1,287.	1,389.	1,459.	1,561.	1,631.
	20"	42"	<b>R3B2TFF42 20-( )()</b>	1,181.	1,215.	1,287.	1,389.	1,459.	1,561.	1,631.
	24"	42"	<b>R3B2TFF42 24-( )()</b>	1,157.	1,191.	1,263.	1,365.	1,435.	1,537.	1,607.
	30"	42"	<b>R3B2TFF42 30-( )()</b>	1,271.	1,305.	1,377.	1,479.	1,549.	1,651.	1,721.
	36"	42"	<b>R3B2TFF42 36-( )()</b>	1,498.	1,532.	1,604.	1,706.	1,776.	1,878.	1,948.
	42"	42"	<b>R3B2TFF42 42-( )()</b>	1,620.	1,654.	1,726.	1,828.	1,898.	2,000.	2,070.
	48"	42"	<b>R3B2TFF42 48-( )()</b>	1,678.	1,712.	1,784.	1,886.	1,956.	2,058.	2,128.

Order Code	Specification Information	Application Notes
Example: <b>R3B2TFF4218-A4K</b>	<i>To order please specify pattern number including:</i>	<i>1. Top trim profile:</i>
<b>R3</b> Reff Generation 3	1. Top trim profile	A = Flat
<b>B2</b> Beltway two sides	2. Base height	B = Square
<b>T</b> Tiled panel	3. Knockout option	C = Bullnose
<b>FF</b> Fabric on both sides	(K = with knockouts, N = without knockouts)	E = Extruded Aluminum
<b>42</b> 42" high	4. Fabric side, finish (specify selection per insert)	<i>2. Base height:</i>
<b>18</b> 18" wide	i) tile 1A bottom	4 = 4" base height
<b>A</b> Flat style top trim profile	ii) tile 1B middle	6 = 6" base height (add \$47 per panel for this option)
<b>4</b> 4" base height	iii) tile 1C top	Note: Extruded aluminum reveal/tile dividers not optional for between fabric inserts.
<b>K</b> Include knockouts in base	5. Fabric side, finish (specify selection per insert)	Applicable finishes are listed on page 5 and 6.
<b>W281</b> Fabric - Side 1A	i) tile 2A bottom	
<b>W281</b> Fabric - Side 1B	ii) tile 2B middle	
<b>W281</b> Fabric - Side 1C	iii) tile 2C top	
<b>W281</b> Fabric - Side 2A	6. Top trim finish	
<b>W281</b> Fabric - Side 2B	i) Top trim profile A,B or C options:	
<b>W281</b> Fabric - Side 2C	V1, V2, V3, P1, P2, P3 finishes	
<b>V316</b> Maple (top trim finish)	ii) Top trim profile E options:	
<b>111</b> Jet Black (base finish)	AA-anodized aluminum or P1, P2, P3 finish listed on page 5 excluding silver	
<b>111</b> Beltway finish	7. Base finish	
	8. Beltway finish	
	9. <i>Optional non-beltway panels:</i>	
	specify (M) for panel frame to be milled for ported components, \$14 list upcharge applicable	

The Reff System does not support the stacking of modules onto 42"H panels. These panels can be used to achieve transaction top height (see transaction tops page).

6" Raceway option increases panel height by 2 3/4".

Product on this page can be attached to posts 42", 49", 64", and 79"H as well as panels 42", 49", 64" and 79"H. Panels on this page will not attach to panels made before April 1997 without an attachment kit from page 117.

Remember to specify Beltway paint finish when applicable.

79"H hookstrip reveal strips are ordered separately from page 117 at no charge.

# Tiled panels 42" H

*fabric one side, laminate other side*

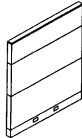
description	w	h	pattern no.	grade						
				10	15	20	30	35	40	45
Tiled, fabric one side Regular acoustics 	18"	42"	<b>R3B0TFL42 18-( ) ( )</b>	\$702.	\$720.	\$756.	\$803.	\$837.	\$885.	\$919.
	20"	42"	<b>R3B0TFL42 20-( ) ( )</b>	702.	720.	756.	803.	837.	885.	919.
	24"	42"	<b>R3B0TFL42 24-( ) ( )</b>	748.	766.	802.	849.	883.	931.	965.
	30"	42"	<b>R3B0TFL42 30-( ) ( )</b>	797.	815.	851.	898.	932.	980.	1,014.
	36"	42"	<b>R3B0TFL42 36-( ) ( )</b>	843.	861.	897.	944.	978.	1,026.	1,060.
	42"	42"	<b>R3B0TFL42 42-( ) ( )</b>	939.	957.	993.	1,040.	1,074.	1,122.	1,156.
	48"	42"	<b>R3B0TFL42 48-( ) ( )</b>	988.	1,006.	1,042.	1,089.	1,123.	1,171.	1,205.

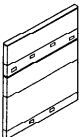
Tiled, fabric one side Beltway one side (fabric side) 	18"	42"	<b>R3B1TFL42 18-( ) ( )</b>	1,198.	1,216.	1,251.	1,299.	1,333.	1,381.	1,415.
	20"	42"	<b>R3B1TFL42 20-( ) ( )</b>	1,198.	1,216.	1,251.	1,299.	1,333.	1,381.	1,415.
	24"	42"	<b>R3B1TFL42 24-( ) ( )</b>	1,223.	1,241.	1,276.	1,324.	1,358.	1,406.	1,440.
	30"	42"	<b>R3B1TFL42 30-( ) ( )</b>	1,284.	1,302.	1,337.	1,385.	1,419.	1,467.	1,501.
	36"	42"	<b>R3B1TFL42 36-( ) ( )</b>	1,502.	1,520.	1,555.	1,603.	1,637.	1,685.	1,719.
	42"	42"	<b>R3B1TFL42 42-( ) ( )</b>	1,615.	1,633.	1,668.	1,716.	1,750.	1,798.	1,832.
	48"	42"	<b>R3B1TFL42 48-( ) ( )</b>	1,667.	1,685.	1,720.	1,768.	1,802.	1,850.	1,884.

Order Code	Specification Information	Application Notes
Example: <b>R3B0TFL4218-A4K</b> <b>R3</b> Reff Generation 3 <b>B0</b> No Beltway <b>T</b> Tiled panel <b>FL</b> Fabric one side, laminate other <b>42</b> 42" high <b>18</b> 18" wide <b>A</b> Flat style top trim profile <b>4</b> 4" base height <b>K</b> Include knockouts in base <b>B</b> Tile divider, black reveal <b>W281</b> Fabric - Side 1A <b>W281</b> Fabric - Side 1B <b>W281</b> Fabric - Side 1C <b>114</b> Folkstone grey - side 2A <b>114</b> Folkstone grey - side 2B <b>114</b> Folkstone grey - side 2C <b>V316</b> Maple (top trim finish) <b>111</b> Jet Black (base finish) <b>M</b> Optional milled frame	To order please specify pattern number including: 1. Top trim profile 2. Base height 3. Knockout option (K = with knockouts, N = without knockouts) 4. Tile divider B = black steel divider or specify AA-anodized aluminum or painted option excluding silver from page 5 for extruded aluminum divider (upcharge applicable for extruded aluminum divider) 5. Fabric side, finish (specify selection per insert) i) tile 1A bottom ii) tile 1B middle iii) tile 1C top 6. Laminate side, finish (specify selection per insert) i) tile 2A bottom ii) tile 2B middle iii) tile 2C top 7. Top trim finish i) Profile A, B or C options: V1, V2, V3, P1, P2, P3 finishes ii) Profile E options: AA-anodized aluminum or painted finish from page 5 excluding silver 8. Base finish 9. Beltway finish 10. <i>Optional non-beltway panels:</i> specify (M) for panel frame to be milled for ported components, \$14 list upcharge applicable	1. <i>Top trim profile:</i> A = Flat B = Square C = Bullnose E = Extruded Aluminum  2. <i>Base height:</i> 4 = 4" base height 6 = 6" base height (add \$47 per panel for this option)  4. <i>Extruded aluminum tile divider: Optional for non fabric side only (fabric side always black)</i> 42"h add per panel: \$25 for 18w and 20w \$28 for 24w and 30w \$34 for 36w and 42w \$42 for 48w  6" Raceway option increases panel height by 2 <sup>3</sup> / <sub>4</sub> ".  Applicable finishes are listed on page 5 and 6.  Product on this page excluding Beltway panels will accept wood grain laminate where laminate is currently an option. Panel product is subject to a 10% upcharge on the base panel price. Refer to panel product upcharge table.

# Tiled panels 42" H

*fabric one side, techwood other side*

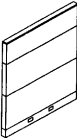
description	w	h	pattern no.	grade						
				10	15	20	30	35	40	45
Tiled, fabric one side	18"	42"	<b>R3B0TF142 18-( )</b> ( )	\$754.	\$772.	\$812.	\$861.	\$895.	\$947.	\$982.
Regular acoustics	20"	42"	<b>R3B0TF142 20-( )</b> ( )	754.	772.	812.	861.	895.	947.	982.
	24"	42"	<b>R3B0TF142 24-( )</b> ( )	804.	822.	862.	911.	945.	997.	1,032.
	30"	42"	<b>R3B0TF142 30-( )</b> ( )	858.	876.	916.	965.	999.	1,051.	1,086.
	36"	42"	<b>R3B0TF142 36-( )</b> ( )	906.	924.	964.	1,013.	1,047.	1,099.	1,134.
	42"	42"	<b>R3B0TF142 42-( )</b> ( )	1,013.	1,031.	1,071.	1,120.	1,154.	1,206.	1,241.
	48"	42"	<b>R3B0TF142 48-( )</b> ( )	1,059.	1,077.	1,117.	1,166.	1,200.	1,252.	1,287.

Tiled, fabric one side	18"	42"	<b>R3B1TF142 18-( )</b> ( )	1,290.	1,308.	1,348.	1,397.	1,431.	1,483.	1,518.
Beltway one side (fabric side)	20"	42"	<b>R3B1TF142 20-( )</b> ( )	1,290.	1,308.	1,348.	1,397.	1,431.	1,483.	1,518.
	24"	42"	<b>R3B1TF142 24-( )</b> ( )	1,315.	1,333.	1,373.	1,422.	1,456.	1,508.	1,543.
	30"	42"	<b>R3B1TF142 30-( )</b> ( )	1,378.	1,396.	1,436.	1,485.	1,519.	1,571.	1,606.
	36"	42"	<b>R3B1TF142 36-( )</b> ( )	1,610.	1,628.	1,668.	1,717.	1,751.	1,803.	1,838.
	42"	42"	<b>R3B1TF142 42-( )</b> ( )	1,735.	1,753.	1,793.	1,842.	1,876.	1,928.	1,963.
	48"	42"	<b>R3B1TF142 48-( )</b> ( )	1,794.	1,812.	1,852.	1,901.	1,935.	1,987.	2,022.

## Order Code

Example: <b>R3B0TF14218-A4K</b>
<b>R3</b> Reff Generation 3
<b>B0</b> No Beltway
<b>T</b> Tiled panel
<b>F1</b> Fabric one side, V1 other
<b>42</b> 42" high
<b>18</b> 18" wide
<b>A</b> Flat style top trim profile
<b>4</b> 4" base height
<b>K</b> Include knockouts in base
<b>B</b> Tile divider, black reveal
<b>W281</b> Fabric - Side 1A
<b>W281</b> Fabric - Side 1B
<b>W281</b> Fabric - Side 1C
<b>Y328</b> Mahogany - side 2 tiled
<b>V316</b> Maple (top trim finish)
<b>111</b> Jet Black (base finish)
<b>M</b> Optional milled frame

## Specification Information

*To order please specify pattern number including:*

- Top trim profile
- Base height
- Knockout option  
(K = with knockouts, N = without knockouts)
- Tile divider  
B = black steel divider or specify AA-anodized aluminum or painted option excluding silver from page 5 for extruded aluminum divider (upcharge applicable for extruded aluminum divider)
- Fabric side, finish (specify selection per insert)
  - tile 1A bottom
  - tile 1B middle
  - tile 1C top
- Techwood side, finish (specify one V1 finish for side)
  - Profile A, B or C options: V1, V2, V3, P1, P2, P3 finishes
  - Profile E options: AA-anodized aluminum or painted finish from page 5 excluding silver
- Base finish
- Beltway finish
- Optional non-beltway panels:* specify (M) for panel frame to be milled for ported components, \$14 list upcharge applicable

## Application Notes

*1. Top trim profile:*  
A = Flat  
B = Square  
C = Bullnose  
E = Extruded Aluminum

*2. Base height:*  
4 = 4" base height  
6 = 6" base height (add \$47 per panel for this option)

*4. Extruded aluminum tile divider:*  
(fabric side always black)  
42" h add per panel:  
\$25 for 18w and 20w  
\$28 for 24w and 30w  
\$34 for 36w and 42w  
\$42 for 48w

6" Raceway option increases panel height by 2 3/4".

Applicable finishes are listed on page 5 and 6.

The Reff System does not support the stacking of modules onto 42"H panels. These panels can be used to achieve transaction top height (see page 407).

Product on this page can be attached to posts 42", 49", 64", and 79"H as well as panels 42", 49", 64" and 79"H. Panels on this page will not attach to panels made before April 1997 without an attachment kit from page 117.

Remember to specify Beltway paint finish when applicable.

79"H hookstrip reveal strips are ordered separately from page 117 at no charge.

# Tiled panels 42" H

*fabric one side, conventional veneer other side*

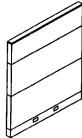
description	w	h	pattern no.	grade						
				10	15	20	30	35	40	45
Tiled, fabric one side	18"	42"	<b>R3B0TF242 18-( ) ( )</b>	\$767.	\$785.	\$825.	\$874.	\$908.	\$960.	\$995.
Regular acoustics	20"	42"	<b>R3B0TF242 20-( ) ( )</b>	767.	785.	825.	874.	908.	960.	995.
	24"	42"	<b>R3B0TF242 24-( ) ( )</b>	818.	836.	876.	925.	959.	1,011.	1,046.
	30"	42"	<b>R3B0TF242 30-( ) ( )</b>	872.	890.	930.	979.	1,013.	1,065.	1,100.
	36"	42"	<b>R3B0TF242 36-( ) ( )</b>	926.	944.	984.	1,033.	1,067.	1,119.	1,154.
	42"	42"	<b>R3B0TF242 42-( ) ( )</b>	1,030.	1,048.	1,088.	1,137.	1,171.	1,223.	1,258.
	48"	42"	<b>R3B0TF242 48-( ) ( )</b>	1,081.	1,099.	1,139.	1,188.	1,222.	1,274.	1,309.

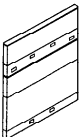
Tiled, fabric one side	18"	42"	<b>R3B1TF242 18-( ) ( )</b>	1,313.	1,331.	1,371.	1,420.	1,454.	1,506.	1,541.
Beltway one side (fabric side)	20"	42"	<b>R3B1TF242 20-( ) ( )</b>	1,313.	1,331.	1,371.	1,420.	1,454.	1,506.	1,541.
	24"	42"	<b>R3B1TF242 24-( ) ( )</b>	1,337.	1,355.	1,395.	1,444.	1,478.	1,530.	1,565.
	30"	42"	<b>R3B1TF242 30-( ) ( )</b>	1,404.	1,422.	1,462.	1,511.	1,545.	1,597.	1,632.
	36"	42"	<b>R3B1TF242 36-( ) ( )</b>	1,643.	1,661.	1,701.	1,750.	1,784.	1,836.	1,871.
	42"	42"	<b>R3B1TF242 42-( ) ( )</b>	1,767.	1,785.	1,825.	1,874.	1,908.	1,960.	1,995.
	48"	42"	<b>R3B1TF242 48-( ) ( )</b>	1,827.	1,845.	1,885.	1,934.	1,968.	2,020.	2,055.

**Order Code**

Example: <b>R3B0TF24218-A4K</b>
<b>R3</b> Reff Generation 3
<b>B0</b> No Beltway
<b>T</b> Tiled panel
<b>F2</b> Fabric one side, V2 other
<b>42</b> 42" high
<b>18</b> 18" wide
<b>A</b> Flat style top trim profile
<b>4</b> 4" base height
<b>K</b> Include knockouts in base
<b>B</b> Tile divider, black reveal
<b>W281</b> Fabric - Side 1A
<b>W281</b> Fabric - Side 1B
<b>W281</b> Fabric - Side 1C
<b>V316</b> Maple surface - side 2 tiled
<b>V316</b> Maple (top trim finish)
<b>111</b> Jet Black (base finish)
<b>M</b> Optional milled frame

**Specification Information**

- To order please specify pattern number including:*
- Top trim profile
  - Base height
  - Knockout option  
(K = with knockouts, N = without knockouts)
  - Tile divider  
B = black steel divider or specify AA-anodized aluminum or painted option excluding silver from page 5 for extruded aluminum divider (upcharge applicable for extruded aluminum divider)
  - Fabric side, finish (specify selection per insert)
    - tile 1A bottom
    - tile 1B middle
    - tile 1C top
  - Conventional veneer, finish (specify one V2 finish for side)
  - Top trim finish
    - Profile A, B or C options: V1, V2, V3, P1, P2, P3 finishes
    - Profile E options: AA-anodized aluminum or painted finish from page 5 excluding silver
  - Base finish
  - Beltway finish
  - Optional non-beltway panels:* specify (M) for panel frame to be milled for ported components, \$14 list upcharge applicable

**Application Notes**

- Top trim profile:*  
A = Flat  
B = Square  
C = Bullnose  
E = Extruded Aluminum
  - Base height:*  
4 = 4" base height  
6 = 6" base height (add \$47 per panel for this option)
  - Extruded aluminum tile divider:*  
**Optional for non fabric side only**  
(fabric side always black)  
42" h add per panel:  
\$25 for 18w and 20w  
\$28 for 24w and 30w  
\$34 for 36w and 42w  
\$42 for 48w
  - 6" Raceway option increases panel height by 2 3/4".
- Applicable finishes are listed on page 5 and 6.

The Reff System does not support the stacking of modules onto 42"H panels. These panels can be used to achieve transaction top height (see page 407).

Product on this page can be attached to posts 42", 49", 64", and 79"H as well as panels 42", 49", 64" and 79"H. Panels on this page will not attach to panels made before April 1997 without an attachment kit from page 117.

Remember to specify Beltway paint finish when applicable.

79"H hookstrip reveal strips are ordered separately from page 117 at no charge.

# Tiled panels 42" H

*fabric one side, exotic veneer other side*

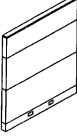
description	w	h	pattern no.	grade						
				10	15	20	30	35	40	45
Tiled, fabric one side Regular acoustics 	18"	42"	<b>R3B0TF342 18-()</b> ( )	\$1,023.	\$1,041.	\$1,081.	\$1,130.	\$1,164.	\$1,216.	\$1,251.
	20"	42"	<b>R3B0TF342 20-()</b> ( )	1,023.	1,041.	1,081.	1,130.	1,164.	1,216.	1,251.
	24"	42"	<b>R3B0TF342 24-()</b> ( )	1,089.	1,107.	1,147.	1,196.	1,230.	1,282.	1,317.
	30"	42"	<b>R3B0TF342 30-()</b> ( )	1,163.	1,181.	1,221.	1,270.	1,304.	1,356.	1,391.
	36"	42"	<b>R3B0TF342 36-()</b> ( )	1,235.	1,253.	1,293.	1,342.	1,376.	1,428.	1,463.
	42"	42"	<b>R3B0TF342 42-()</b> ( )	1,376.	1,394.	1,434.	1,483.	1,517.	1,569.	1,604.
	48"	42"	<b>R3B0TF342 48-()</b> ( )	1,445.	1,463.	1,503.	1,552.	1,586.	1,638.	1,673.

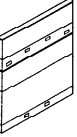
Tiled, fabric one side Beltway fabric side 	18"	42"	<b>R3B1TF342 18-()</b> ( )	1,759.	1,777.	1,817.	1,866.	1,900.	1,952.	1,987.
	20"	42"	<b>R3B1TF342 20-()</b> ( )	1,759.	1,777.	1,817.	1,866.	1,900.	1,952.	1,987.
	24"	42"	<b>R3B1TF342 24-()</b> ( )	1,792.	1,810.	1,850.	1,899.	1,933.	1,985.	2,020.
	30"	42"	<b>R3B1TF342 30-()</b> ( )	1,880.	1,898.	1,938.	1,987.	2,021.	2,073.	2,108.
	36"	42"	<b>R3B1TF342 36-()</b> ( )	2,204.	2,222.	2,262.	2,311.	2,345.	2,397.	2,432.
	42"	42"	<b>R3B1TF342 42-()</b> ( )	2,370.	2,388.	2,428.	2,477.	2,511.	2,563.	2,598.
	48"	42"	<b>R3B1TF342 48-()</b> ( )	2,452.	2,470.	2,510.	2,559.	2,593.	2,645.	2,680.

Order Code	Specification Information	Application Notes	
Example: <b>R3B0TF34218-A4K</b> <b>R3</b> Reff Generation 3 <b>B0</b> No Beltway <b>T</b> Tiled panel <b>F3</b> Fabric one side, V3 other <b>42</b> 42" high <b>18</b> 18" wide <b>A</b> Flat style top trim profile <b>4</b> 4" base height <b>K</b> Include knockouts in base <b>B</b> Tile divider, black reveal <b>W281</b> Fabric - Side 1A <b>W281</b> Fabric - Side 1B <b>W281</b> Fabric - Side 1C <b>V512</b> Figured Anigre surface - side 2 tiled <b>V512</b> Figured Anigre (top trim finish) <b>111</b> Jet Black (base finish) <b>M</b> Optional milled frame	To order please specify pattern number including: 1. Top trim profile 2. Base height 3. Knockout option (K = with knockouts, N = without knockouts) 4. Tile divider B = black steel divider or specify AA-anodized aluminum or painted option excluding silver from page 5 for extruded aluminum divider (upcharge applicable for extruded aluminum divider) 5. Fabric side, finish (specify selection per insert) i) tile 1A bottom ii) tile 1B middle iii) tile 1C top 6. Exotic veneer, finish (specify one V3 finish for side) 7. Top trim finish i) Profile A, B or C options: V1, V2, V3, P1, P2, P3 finishes ii) Profile E options: AA-anodized aluminum or painted finish from page 5 excluding silver 8. Base finish 9. Beltway finish 10. <i>Optional non-beltway panels:</i> specify (M) for panel frame to be milled for ported components, \$14 list upcharge applicable	1. <i>Top trim profile:</i> A = Flat B = Square C = Bullnose E = Extruded Aluminum 2. <i>Base height:</i> 4 = 4" base height 6 = 6" base height (add \$47 per panel for this option) 4. <i>Extruded aluminum tile divider: Optional for non fabric side only</i> (fabric side always black) 42"h add per panel: \$25 for 18w and 20w \$28 for 24w and 30w \$34 for 36w and 42w \$42 for 48w 6" Raceway option increases panel height by 2 3/4". Applicable finishes are listed on page 5 and 6.	The Reff System does not support the stacking of modules onto 42"H panels. These panels can be used to achieve transaction top height (see page 407). Product on this page can be attached to posts 42", 49", 64", and 79"H as well as panels 42", 49", 64" and 79"H. Panels on this page will not attach to panels made before April 1997 without an attachment kit from page 117. Remember to specify Beltway paint finish when applicable. 79"H hookstrip reveal strips are ordered separately from page 117 at no charge.

# Tiled panels 42" H Laminate/Laminate

description	w	h	pattern no.	L
Tiled, laminate both sides with raceway both sides	18"	42"	<b>R3B0TLL4218( ) ( )</b>	\$855.
	20"	42"	<b>R3B0TLL4220( ) ( )</b>	855.
	24"	42"	<b>R3B0TLL4224( ) ( )</b>	933.
	30"	42"	<b>R3B0TLL4230( ) ( )</b>	1,044.
	36"	42"	<b>R3B0TLL4236( ) ( )</b>	1,127.
	42"	42"	<b>R3B0TLL4242( ) ( )</b>	1,162.
	48"	42"	<b>R3B0TLL4248( ) ( )</b>	1,196.

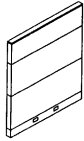

Order Code	Specification Information	Application Notes
Example: <b>R3B0TLL4218-A4K</b>	<i>To order please specify pattern number including:</i>	
<b>R3</b> Reff Generation 3	1. Top trim profile	1. <i>Top trim profile:</i> A = Flat B = Square C = Bullnose E = Extruded Aluminum
<b>B0</b> No Beltway	2. Base height	2. <i>Base height:</i> 4 = 4" base height
<b>T</b> Tiled panel	3. Knockout option (K = with knockouts, N = without knockouts)	4. <i>Extruded aluminum tile divider:</i> <b>Optional for non fabric side only</b> (fabric side always black) 42"h add per panel: \$25 for 18w and 20w \$28 for 24w and 30w \$34 for 36w and 42w \$42 for 48w
<b>LL</b> Laminate both sides	4. Tile divider B = black steel divider or specify AA-anodized aluminum or painted option excluding silver from page 5 for extruded aluminum divider (upcharge applicable for extruded aluminum divider)	Applicable finishes are listed on page 5 and 6.
<b>42</b> 42" high	5. Laminate side, finish (specify selection per insert)	Product on this page will accept wood grain laminate where laminate is currently an option. Panel product is subject to a 10% upcharge on the base panel price. Refer to panel product upcharge table.
<b>18</b> 18" wide	i) tile 1A bottom ii) tile 1B middle iii) tile 1C top	
<b>A</b> Flat style top trim profile	6. Laminate, finish	
<b>4</b> 4" base height	7. Top trim finish	
<b>K</b> Include knockouts in base	i) Profile A, B or C options: V1, V2, V3, P1, P2, P3 finishes ii) Profile E options: AA-anodized aluminum or painted finish from page 5 excluding silver	
<b>B</b> Tile divider, black reveal	8. Base finish	
<b>118</b> Laminate - side 1A	9. Beltway finish	
<b>118</b> Laminate - side 1B	10. <i>Optional non-beltway panels:</i> specify (M) for panel frame to be milled for ported components, \$14 list upcharge applicable	79"H hookstrip reveal strips are ordered separately from page 117 at no charge.
<b>118</b> Laminate - side 1C		
<b>118</b> Laminate - side 2A		
<b>118</b> Laminate - side 2B		
<b>118</b> Laminate - side 2C		
<b>V512</b> Figured Anigre (top trim finish)		
<b>111</b> Jet Black (base finish)		
<b>M</b> Optional milled frame		

# Tiled panels 49" H

*fabric both sides*

description	w	h	pattern no.	grade						
				10	15	20	30	35	40	45
Tiled, fabric both sides Regular acoustics	18"	49"	<b>R3B0TFF49 18-</b> ( ) ( )	\$723.	\$765.	\$855.	\$951.	\$1,035.	\$1,161.	\$1,239.
	20"	49"	<b>R3B0TFF49 20-</b> ( ) ( )	723.	765.	855.	951.	1,035.	1,161.	1,239.
	24"	49"	<b>R3B0TFF49 24-</b> ( ) ( )	773.	815.	905.	1,001.	1,085.	1,211.	1,289.
	30"	49"	<b>R3B0TFF49 30-</b> ( ) ( )	831.	873.	963.	1,059.	1,143.	1,269.	1,347.
	36"	49"	<b>R3B0TFF49 36-</b> ( ) ( )	885.	927.	1,017.	1,113.	1,197.	1,323.	1,401.
	42"	49"	<b>R3B0TFF49 42-</b> ( ) ( )	999.	1,041.	1,131.	1,227.	1,311.	1,437.	1,515.
	48"	49"	<b>R3B0TFF49 48-</b> ( ) ( )	1,054.	1,096.	1,186.	1,282.	1,366.	1,492.	1,570.

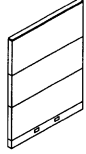

Tiled, fabric both sides High acoustics	18"	49"	<b>R3B0TAA49 18-</b> ( ) ( )	792.	834.	924.	1,020.	1,104.	1,230.	1,308.
	20"	49"	<b>R3B0TAA49 20-</b> ( ) ( )	792.	834.	924.	1,020.	1,104.	1,230.	1,308.
	24"	49"	<b>R3B0TAA49 24-</b> ( ) ( )	846.	888.	978.	1,074.	1,158.	1,284.	1,362.
	30"	49"	<b>R3B0TAA49 30-</b> ( ) ( )	913.	955.	1,045.	1,141.	1,225.	1,351.	1,429.
	36"	49"	<b>R3B0TAA49 36-</b> ( ) ( )	972.	1,014.	1,104.	1,200.	1,284.	1,410.	1,488.
	42"	49"	<b>R3B0TAA49 42-</b> ( ) ( )	1,095.	1,137.	1,227.	1,323.	1,407.	1,533.	1,611.
	48"	49"	<b>R3B0TAA49 48-</b> ( ) ( )	1,159.	1,201.	1,291.	1,387.	1,471.	1,597.	1,675.

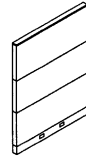

Order Code	Specification Information	Application Notes
Example: <b>R3B0TFF4918-A4K</b>	<i>To order please specify pattern number including:</i>	
<b>R3</b> Reff Generation 3	1. Top trim profile	1. <i>Top trim profile:</i> A = Flat B = Square C = Bullnose E = Extruded Aluminum
<b>B0</b> No Beltway	2. Base height	
<b>T</b> Tiled panel	3. Knockout option (K = with knockouts, N = without knockouts)	2. <i>Base height:</i> 4 = 4" base height 6 = 6" base height (add \$47 per panel for this option)
<b>FF</b> Fabric on both sides	4. Fabric side finish (specify selection per insert)	
<b>49</b> 49" high	<i>i</i> ) tile 1A bottom	6" Raceway option increases panel height by 2 <sup>3</sup> / <sub>4</sub> ".
<b>18</b> 18" wide	<i>ii</i> ) tile 1B middle	
<b>A</b> Flat style top trim profile	<i>iii</i> ) tile 1C top	Note: Extruded aluminum reveal/tile dividers are not optional for between fabric inserts.
<b>4</b> 4" base height	5. Fabric side, finish (specify selection per insert)	
<b>K</b> Include knockouts in base	<i>i</i> ) tile 2A bottom	Applicable finishes are listed on page 5 and 6.
<b>W281</b> Fabric - Side 1A	<i>ii</i> ) tile 2B middle	
<b>W281</b> Fabric - Side 1B	<i>iii</i> ) tile 2C top	79"H hookstrip reveal strips are ordered separately from page 117 at no charge.
<b>W281</b> Fabric - Side 1C	6. Top trim finish	
<b>W281</b> Fabric - Side 2A	<i>i</i> ) Top trim profile A,B or C options:	
<b>W281</b> Fabric - Side 2B	<i>ii</i> ) Top trim profile E options:	
<b>W281</b> Fabric - Side 2C	AA-anodized aluminum or P1, P2, P3 finish listed on page 5 excluding silver	
<b>V316</b> Maple (top trim finish)	7. Base finish	
<b>111</b> Jet Black (base finish)	8. Beltway finish	
<b>M</b> Optional milled frame	9. <i>Optional non-beltway panels:</i> specify (M) for panel frame to be milled for ported components, \$14 list upcharge applicable	



# Tiled panels 49" H

## *fabric both sides with Beltway*

description	w	h	pattern no.	grade						
				10	15	20	30	35	40	45
Tiled, fabric both sides	18"	49"	<b>R3B1TFF49 18-</b> ( ) ( )	\$1,191.	\$1,233.	\$1,320.	\$1,419.	\$1,503.	\$1,629.	\$1,707.
Beltway one side	20"	49"	<b>R3B1TFF49 20-</b> ( ) ( )	1,191.	1,233.	1,320.	1,419.	1,503.	1,629.	1,707.
	24"	49"	<b>R3B1TFF49 24-</b> ( ) ( )	1,215.	1,257.	1,344.	1,443.	1,527.	1,653.	1,731.
	30"	49"	<b>R3B1TFF49 30-</b> ( ) ( )	1,280.	1,322.	1,409.	1,508.	1,592.	1,718.	1,796.
	36"	49"	<b>R3B1TFF49 36-</b> ( ) ( )	1,532.	1,574.	1,661.	1,760.	1,844.	1,970.	2,048.
	42"	49"	<b>R3B1TFF49 42-</b> ( ) ( )	1,654.	1,696.	1,783.	1,882.	1,966.	2,092.	2,170.
	48"	49"	<b>R3B1TFF49 48-</b> ( ) ( )	1,712.	1,754.	1,841.	1,940.	2,024.	2,150.	2,228.

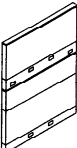
Tiled, fabric both sides	18"	49"	<b>R3B2TFF49 18-</b> ( ) ( )	1,209.	1,251.	1,335.	1,437.	1,521.	1,647.	1,725.
Beltway two sides	20"	49"	<b>R3B2TFF49 20-</b> ( ) ( )	1,209.	1,251.	1,335.	1,437.	1,521.	1,647.	1,725.
	24"	49"	<b>R3B2TFF49 24-</b> ( ) ( )	1,236.	1,278.	1,362.	1,464.	1,548.	1,674.	1,752.
	30"	49"	<b>R3B2TFF49 30-</b> ( ) ( )	1,304.	1,346.	1,430.	1,532.	1,616.	1,742.	1,820.
	36"	49"	<b>R3B2TFF49 36-</b> ( ) ( )	1,559.	1,601.	1,685.	1,787.	1,871.	1,997.	2,075.
	42"	49"	<b>R3B2TFF49 42-</b> ( ) ( )	1,682.	1,724.	1,808.	1,910.	1,994.	2,120.	2,198.
	48"	49"	<b>R3B2TFF49 48-</b> ( ) ( )	1,746.	1,788.	1,872.	1,974.	2,058.	2,184.	2,264.

Order Code	Specification Information	Application Notes
Example: <b>R3B2TFF4918-A4K</b>	<i>To order please specify pattern number including:</i>	<i>1. Top trim profile:</i>
<b>R3</b> Reff Generation 3	1. Top trim profile	A = Flat
<b>B2</b> with Beltway	2. Base height	B = Square
<b>T</b> Tiled panel	3. Knockout option	C = Bullnose
<b>FF</b> Fabric on both sides	(K = with knockouts, N = without knockouts)	E = Extruded Aluminum
<b>49</b> 49" high	4. Fabric side finish (specify selection per insert)	<i>2. Base height:</i>
<b>18</b> 18" wide	i) tile 1A bottom	4 = 4" base height
<b>A</b> Flat style top trim profile	ii) tile 1B middle	6 = 6" base height (add \$47 per panel for this option)
<b>4</b> 4" base height	iii) tile 1C top	6" Raceway option increases panel height by 2 <sup>3</sup> / <sub>4</sub> ".
<b>K</b> Include knockouts in base	5. Fabric side, finish (specify selection per insert)	Note: Extruded aluminum reveal/tile dividers are not optional for between fabric inserts.
<b>W281</b> Fabric - Side 1A	i) tile 2A bottom	Applicable finishes are listed on page 5 and 6.
<b>W281</b> Fabric - Side 1B	ii) tile 2B middle	
<b>W281</b> Fabric - Side 1C	iii) tile 2C top	
<b>W281</b> Fabric - Side 2A	6. Top trim finish	
<b>W281</b> Fabric - Side 2B	i) Top trim profile A,B or C options:	
<b>W281</b> Fabric - Side 2C	V1, V2, V3, P1, P2, P3 finishes	
<b>V316</b> Maple (top trim finish)	ii) Top trim profile E options:	
<b>111</b> Jet Black (base finish)	AA-anodized aluminum or P1, P2, P3 finish listed on page 5 excluding silver	
<b>111</b> Beltway finish	7. Base finish	
	8. Beltway finish	
	9. <i>Optional non-beltway panels:</i>	
	specify (M) for panel frame to be milled for ported components, \$14 list upcharge applicable	

The panels on this page will accept stacking modules to increase their height on 18" to 48"W panels only. The 60" to 72"W panels will not accept stacking modules on top of themselves.

Product on this page can be attached to posts 49", 64", and 79"H as well as panels 42", 49", 64" and 79"H. Panels on this page will not attach to panels made before April 1997 without an attachment kit from page 117.

Remember to specify Beltway paint finish when applicable.

79"H hookstrip reveal strips are ordered separately from page 117 at no charge.

# Tiled panels 49" H

*fabric one side, laminate opposite side*

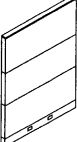
description	w	h	pattern no.	grade						
				10	15	20	30	35	40	45
Tiled, fabric one side	18"	49"	<b>R3B0TFL49 18-()</b> ( )	\$788.	\$809.	\$851.	\$899.	\$941.	\$998.	\$1,037.
Regular acoustics	20"	49"	<b>R3B0TFL49 20-()</b> ( )	788.	809.	851.	899.	941.	998.	1,037.
	24"	49"	<b>R3B0TFL49 24-()</b> ( )	833.	854.	896.	944.	986.	1,043.	1,082.
	30"	49"	<b>R3B0TFL49 30-()</b> ( )	892.	913.	955.	1,003.	1,045.	1,102.	1,141.
	36"	49"	<b>R3B0TFL49 36-()</b> ( )	941.	962.	1,004.	1,052.	1,094.	1,151.	1,190.
	42"	49"	<b>R3B0TFL49 42-()</b> ( )	1,049.	1,070.	1,112.	1,160.	12,012.	1,259.	1,298.
	48"	49"	<b>R3B0TFL49 48-()</b> ( )	1,105.	1,126.	1,168.	1,216.	1,258.	1,315.	1,354.

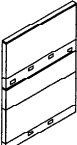
Tiled, fabric one side	18"	49"	<b>R3B1TFL49 18-()</b> ( )	1,237.	1,258.	1,299.	1,348.	1,390.	1,447.	1,486.
Beltway one side (fabric side)	20"	49"	<b>R3B1TFL49 20-()</b> ( )	1,237.	1,258.	1,299.	1,348.	1,390.	1,447.	1,486.
	24"	49"	<b>R3B1TFL49 24-()</b> ( )	1,262.	1,283.	1,324.	1,373.	1,415.	1,472.	1,511.
	30"	49"	<b>R3B1TFL49 30-()</b> ( )	1,326.	1,347.	1,388.	1,437.	1,479.	1,536.	1,575.
	36"	49"	<b>R3B1TFL49 36-()</b> ( )	1,566.	1,587.	1,628.	1,677.	1,719.	1,776.	1,815.
	42"	49"	<b>R3B1TFL49 42-()</b> ( )	1,681.	1,702.	1,743.	1,792.	1,834.	1,891.	1,930.
	48"	49"	<b>R3B1TFL49 48-()</b> ( )	1,744.	1,765.	1,806.	1,855.	1,897.	1,954.	1,993.

Order Code	Specification Information	Application Notes
Example: <b>R3B0TFL4918-A4K</b>	<i>To order please specify pattern number including:</i>	
<b>R3</b> Reff Generation 3	1. Top trim profile	1. <i>Top trim profile:</i> A = Flat B = Square C = Bullnose E = Extruded Aluminum
<b>B0</b> No Beltway	2. Base height	2. <i>Base height:</i> 4 = 4" base height 6 = 6" base height (add \$47 per panel for this option)
<b>T</b> Tiled panel	3. Knockout option (K = with knockouts, N = without knockouts)	4. <i>Extruded aluminum tile divider:</i> <b>Optional for non fabric side only</b> (fabric side always black) 49"h add per panel: \$25 for 18w and 20w \$28 for 24w and 30w \$34 for 36w and 42w \$42 for 48w
<b>FL</b> Fabric one side. laminate other	4. Tile divider B = black steel divider or specify AA-anodized aluminum or painted option excluding silver from page 5 for extruded aluminum divider (upcharge applicable for extruded aluminum divider)	6" Raceway option increases panel height by 2 3/4".
<b>49</b> 49" high	5. Fabric side, finish (specify selection per insert) i) tile 1A bottom ii) tile 1B middle iii) tile 1C top	Applicable finishes are listed on page 5 and 6.
<b>18</b> 18" wide	6. Laminate side finish (specify selection per insert) i) tile 2A bottom ii) tile 2B middle iii) tile 2C top	Product on this page excluding Beltway panels will accept wood grain laminate where laminate is currently an option. Panel product is subject to a 10% upcharge on the base panel price. Refer to panel product upcharge table.
<b>A</b> Flat style top trim profile	7. Top trim finish i) Profile A, B or C options: V1, V2, V3, P1, P2, P3 finishes ii) Profile E options: AA-anodized aluminum or painted finish from page 5 excluding silver	
<b>4</b> 4" base height	8. Base finish	
<b>K</b> Include knockouts in base	9. Beltway finish, for panels with Beltway	
<b>B</b> Tile divider, black reveal	10. <i>Optional non-beltway panels:</i> specify (M) for panel frame to be milled for ported components, \$14 list upcharge applicable	
<b>W281</b> Fabric - Side 1A		
<b>W281</b> Fabric - Side 1B		
<b>W281</b> Fabric - Side 1C		
<b>114</b> Folkstone grey - side 2A		
<b>114</b> Folkstone grey - side 2B		
<b>114</b> Folkstone grey - side 2C		
<b>V316</b> Maple (top trim finish)		
<b>111</b> Jet Black (base finish)		
<b>M</b> Optional milled frame		

# Tiled panels 49" H

*fabric one side, techwood other side*

description	w	h	pattern no.	grade						
				10	15	20	30	35	40	45
Tiled, fabric one side	18"	49"	<b>R3B0TF149 18-()</b> ( )	\$843.	\$864.	\$912.	\$960.	\$1,002.	\$1,065.	\$1,104.
Regular acoustics	20"	49"	<b>R3B0TF149 20-()</b> ( )	843.	864.	912.	960.	1,002.	1,065.	1,104.
	24"	49"	<b>R3B0TF149 24-()</b> ( )	896.	917.	965.	1,013.	1,055.	1,118.	1,157.
	30"	49"	<b>R3B0TF149 30-()</b> ( )	956.	977.	1,025.	1,073.	1,115.	1,178.	1,217.
	36"	49"	<b>R3B0TF149 36-()</b> ( )	1,013.	1,034.	1,082.	1,130.	1,172.	1,235.	1,274.
	42"	49"	<b>R3B0TF149 42-()</b> ( )	1,133.	1,154.	1,202.	1,250.	1,292.	1,355.	1,394.
	48"	49"	<b>R3B0TF149 48-()</b> ( )	1,187.	1,208.	1,256.	1,304.	1,346.	1,409.	1,448.

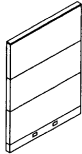

Tiled, fabric one side	18"	49"	<b>R3B1TF149 18-()</b> ( )	1,329.	1,350.	1,398.	1,446.	1,488.	1,551.	1,590.
Beltway one side (fabric side)	20"	49"	<b>R3B1TF149 20-()</b> ( )	1,329.	1,350.	1,398.	1,446.	1,488.	1,551.	1,590.
	24"	49"	<b>R3B1TF149 24-()</b> ( )	1,359.	1,380.	1,428.	1,476.	1,518.	1,581.	1,620.
	30"	49"	<b>R3B1TF149 30-()</b> ( )	1,425.	1,446.	1,494.	1,542.	1,584.	1,647.	1,686.
	36"	49"	<b>R3B1TF149 36-()</b> ( )	1,686.	1,707.	1,755.	1,803.	1,845.	1,908.	1,947.
	42"	49"	<b>R3B1TF149 42-()</b> ( )	1,811.	1,832.	1,880.	1,928.	1,970.	2,033.	2,072.
	48"	49"	<b>R3B1TF149 48-()</b> ( )	1,873.	1,894.	1,942.	1,990.	2,032.	2,095.	2,134.

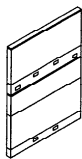

Order Code	Specification Information	Application Notes
Example: <b>R3B0TF14918-A4K</b>	<i>To order please specify pattern number including:</i>	<i>1. Top trim profile:</i>
<b>R3</b> Reff Generation 3	1. Top trim profile	A = Flat
<b>B0</b> No Beltway	2. Base height	B = Square
<b>T</b> Tiled panel	3. Knockout option (K = with knockouts, N = without knockouts)	C = Bullnose
<b>F1</b> Fabric one side, V1 other	4. Tile divider (B = black steel divider or specify AA-anodized aluminum or painted option excluding silver from page 5 for extruded aluminum divider (upcharge applicable for extruded aluminum divider))	E = Extruded Aluminum
<b>49</b> 49" high	5. Fabric side, finish (specify selection per insert)	<i>2. Base height:</i>
<b>18</b> 18" wide	i) tile 1A bottom	4 = 4" base height
<b>A</b> Flat style top trim profile	ii) tile 1B middle	6 = 6" base height (add \$47 per panel for this option)
<b>4</b> 4" base height	iii) tile 1C top	<i>4. Extruded aluminum tile divider: Optional for non fabric side only (fabric side always black)</i>
<b>K</b> Include knockouts in base	6. Techwood side, finish (specify one V1 finish for side)	49"h add per panel: \$25 for 18w and 20w \$28 for 24w and 30w \$34 for 36w and 42w \$42 for 48w
<b>B</b> Tile divider, black reveal	7. Top trim finish	6" Raceway option increases panel height by 2 3/4".
<b>W281</b> Fabric - Side 1A	i) Profile A, B or C options: V1, V2, V3, P1, P2, P3 finishes	Applicable finishes are listed on page 5 and 6.
<b>W281</b> Fabric - Side 1B	ii) Profile E options: AA-anodized aluminum or painted finish from page 5 excluding silver	
<b>W281</b> Fabric - Side 1C	8. Base finish	
<b>Y328</b> Mahogany - side 2 tiled	9. Beltway finish, for panels with Beltway	
<b>V316</b> Maple (top trim finish)	10. <i>Optional non-beltway panels:</i> specify (M) for panel frame to be milled for ported components, \$14 list upcharge applicable	
<b>111</b> Jet Black (base finish)		
<b>M</b> Optional milled frame		

The panels on this page will accept stacking modules to increase their height on 18" to 48"W panels only. The 60" to 72"W panels will not accept stacking modules on top of themselves.

Product on this page can be attached to posts 49", 64", and 79"H as well as panels 42", 49", 64" and 79"H. Panels on this page will not attach to panels made before April 1997 without an attachment kit from page 117.

Remember to specify Beltway paint finish when applicable.

79"H hookstrip reveal strips are ordered separately from page 117 at no charge.

# Tiled panels 49" H

*fabric one side, conventional veneer other side*

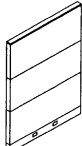
description	w	h	pattern no.	grade						
				10	15	20	30	35	40	45
Tiled, fabric one side	18"	49"	<b>R3B0TF249 18-()</b> ( )	\$861.	\$882.	\$930.	\$978.	\$1,020.	\$1,083.	\$1,122.
Regular acoustics	20"	49"	<b>R3B0TF249 20-()</b> ( )	861.	882.	930.	978.	1,020.	1,083.	1,122.
	24"	49"	<b>R3B0TF249 24-()</b> ( )	912.	933.	981.	1,029.	1,071.	1,134.	1,173.
	30"	49"	<b>R3B0TF249 30-()</b> ( )	979.	1,000.	1,048.	1,096.	1,138.	1,201.	1,240.
	36"	49"	<b>R3B0TF249 36-()</b> ( )	1,032.	1,053.	1,101.	1,149.	1,191.	1,254.	1,293.
	42"	49"	<b>R3B0TF249 42-()</b> ( )	1,149.	1,170.	1,218.	1,266.	1,308.	1,371.	1,410.
	48"	49"	<b>R3B0TF249 48-()</b> ( )	1,209.	1,230.	1,278.	1,326.	1,368.	1,431.	1,470.

Tiled, fabric one side	18"	49"	<b>R3B1TF249 18-()</b> ( )	1,355.	1,376.	1,424.	1,472.	1,514.	1,577.	1,616.
Beltway one side (fabric side)	20"	49"	<b>R3B1TF249 20-()</b> ( )	1,355.	1,376.	1,424.	1,472.	1,514.	1,577.	1,616.
	24"	49"	<b>R3B1TF249 24-()</b> ( )	1,383.	1,404.	1,452.	1,500.	1,542.	1,605.	1,644.
	30"	49"	<b>R3B1TF249 30-()</b> ( )	1,450.	1,471.	1,519.	1,567.	1,609.	1,672.	1,711.
	36"	49"	<b>R3B1TF249 36-()</b> ( )	1,714.	1,735.	1,783.	1,831.	1,873.	1,936.	1,975.
	42"	49"	<b>R3B1TF249 42-()</b> ( )	1,842.	1,863.	1,911.	1,959.	2,001.	2,064.	2,103.
	48"	49"	<b>R3B1TF249 48-()</b> ( )	1,908.	1,929.	1,977.	2,025.	2,067.	2,130.	2,169.

Order Code	Specification Information	Application Notes
Example: <b>R3B0TF24918-A4K</b>	<i>To order please specify pattern number including:</i>	<i>1. Top trim profile:</i>
<b>R3</b> Reff Generation 3	1. Top trim profile	A = Flat
<b>B0</b> No Beltway	2. Base height	B = Square
<b>T</b> Tiled panel	3. Knockout option (K = with knockouts, N = without knockouts)	C = Bullnose
<b>F2</b> Fabric one side, V2 other	4. Tile divider B = black steel divider or specify AA-anodized aluminum or painted option excluding silver from page 5 for extruded aluminum divider (upcharge applicable for extruded aluminum divider)	E = Extruded Aluminum
<b>49</b> 49" high	5. Fabric side, finish (specify selection per insert)	<i>2. Base height:</i>
<b>18</b> 18" wide	i) tile 1A bottom	4 = 4" base height
<b>A</b> Flat style top trim profile	ii) tile 1B middle	6 = 6" base height (add \$47 per panel for this option)
<b>4</b> 4" base height	iii) tile 1C top	<i>4. Extruded aluminum tile divider: Optional for non fabric side only (fabric side always black)</i>
<b>K</b> Include knockouts in base	6. Conventional veneer, finish (specify one V2 finish for side)	49"h add per panel:
<b>B</b> Tile divider, black reveal	7. Top trim finish	\$25 for 18w and 20w
<b>W281</b> Fabric - Side 1A	i) Profile A, B or C options: V1, V2, V3, P1, P2, P3 finishes	\$28 for 24w and 30w
<b>W281</b> Fabric - Side 1B	ii) Profile E options: AA-anodized aluminum or painted finish from page 5 excluding silver	\$34 for 36w and 42w
<b>W281</b> Fabric - Side 1C	8. Base finish	\$42 for 48w
<b>V316</b> Maple surface - side 2 tiled	9. Beltway finish, for panels with Beltway	6" Raceway option increases panel height by 2 3/4".
<b>V316</b> Maple (top trim finish)	10. <i>Optional non-beltway panels:</i> specify (M) for panel frame to be milled for ported components, \$14 list upcharge applicable	Applicable finishes are listed on page 5 and 6.
<b>111</b> Jet Black (base finish)		
<b>M</b> Optional milled frame		

# Tiled panels 49" H

*fabric one side, exotic veneer other side*

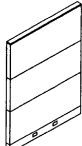
description	w	h	pattern no.	grade						
				10	15	20	30	35	40	45
Tiled, fabric one side	18"	49"	<b>R3B0TF349 18-()</b> ( )	\$1,144.	\$1,165.	\$1,213.	\$1,261.	\$1,303.	\$1,366.	\$1,405.
Regular acoustics	20"	49"	<b>R3B0TF349 20-()</b> ( )	1,144.	1,165.	1,213.	1,261.	1,303.	1,366.	1,405.
	24"	49"	<b>R3B0TF349 24-()</b> ( )	1,214.	1,235.	1,283.	1,331.	1,373.	1,436.	1,475.
	30"	49"	<b>R3B0TF349 30-()</b> ( )	1,304.	1,325.	1,373.	1,421.	1,463.	1,526.	1,565.
	36"	49"	<b>R3B0TF349 36-()</b> ( )	1,377.	1,398.	1,446.	1,494.	1,536.	1,599.	1,638.
	42"	49"	<b>R3B0TF349 42-()</b> ( )	1,534.	1,555.	1,603.	1,651.	1,693.	1,756.	1,795.
	48"	49"	<b>R3B0TF349 48-()</b> ( )	1,614.	1,635.	1,683.	1,731.	1,773.	1,836.	1,875.

Tiled, fabric one side	18"	49"	<b>R3B1TF349 18-()</b> ( )	1,812.	1,833.	1,881.	1,929.	1,971.	2,034.	2,073.
Beltway fabric side	20"	49"	<b>R3B1TF349 20-()</b> ( )	1,812.	1,833.	1,881.	1,929.	1,971.	2,034.	2,073.
	24"	49"	<b>R3B1TF349 24-()</b> ( )	1,851.	1,872.	1,920.	1,968.	2,010.	2,073.	2,112.
	30"	49"	<b>R3B1TF349 30-()</b> ( )	1,940.	1,961.	2,009.	2,057.	2,099.	2,162.	2,201.
	36"	49"	<b>R3B1TF349 36-()</b> ( )	2,298.	2,319.	2,367.	2,415.	2,457.	2,520.	2,559.
	42"	49"	<b>R3B1TF349 42-()</b> ( )	2,471.	2,492.	2,540.	2,588.	2,630.	2,693.	2,732.
	48"	49"	<b>R3B1TF349 48-()</b> ( )	2,561.	2,582.	2,630.	2,678.	2,720.	2,783.	2,820.

Order Code	Specification Information	Application Notes
Example: <b>R3B0TF34918-A4K</b>	<i>To order please specify pattern number including:</i>	<i>1. Top trim profile:</i>
<b>R3</b> Reff Generation 3	1. Top trim profile	A = Flat
<b>B0</b> No Beltway	2. Base height	B = Square
<b>T</b> Tiled panel	3. Knockout option	C = Bullnose
<b>F3</b> Fabric one side, V3 other	(K = with knockouts, N = without knockouts)	E = Extruded Aluminum
<b>49</b> 49" high	4. Tile divider	<i>2. Base height:</i>
<b>18</b> 18" wide	B = black steel divider or specify AA-anodized aluminum or painted option excluding silver from page 5 for extruded aluminum divider (upcharge applicable for extruded aluminum divider)	4 = 4" base height
<b>A</b> Flat style top trim profile	5. Fabric side, finish (specify selection per insert)	6 = 6" base height (add \$47 per panel for this option)
<b>4</b> 4" base height	<i>i) tile 1A bottom</i>	<i>4. Extruded aluminum tile divider: Optional for non fabric side only (fabric side always black)</i>
<b>K</b> Include knockouts in base	<i>ii) tile 1B middle</i>	49" h add per panel:
<b>B</b> Tile divider, black reveal	<i>iii) tile 1C top</i>	\$25 for 18w and 20w
<b>W281</b> Fabric - Side 1A	6. Exotic veneer, finish (specify one V3 finish for side)	\$28 for 24w and 30w
<b>W281</b> Fabric - Side 1B	7. Top trim finish	\$34 for 36w and 42w
<b>W281</b> Fabric - Side 1C	<i>i) Profile A, B or C options: V1, V2, V3, P1, P2, P3 finishes</i>	\$42 for 48w
<b>V512</b> Figured Anigre surface - side 2 tiled	<i>ii) Profile E options: AA-anodized aluminum or painted finish from page 5 excluding silver</i>	6" Raceway option increases panel height by 2 3/4".
<b>V512</b> Figured Anigre (top trim finish)	8. Base finish	Applicable finishes are listed on page 5 and 6.
<b>111</b> Jet Black (base finish)	9. Beltway finish, for panels with Beltway	
<b>M</b> Optional milled frame	10. <i>Optional non-beltway panels:</i> specify (M) for panel frame to be milled for ported components, \$14 list upcharge applicable	

# Tiled panels 49" H

## Laminate/Laminate

Reff Profiles

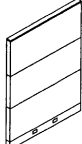
description	w	h	pattern no.	L
Tiled, laminate both sides with raceway both sides 	18"	49"	<b>R3B0TLL4918( ) ( )</b>	\$894.
	20"	49"	<b>R3B0TLL4920( ) ( )</b>	894.
	24"	49"	<b>R3B0TLL4924( ) ( )</b>	974.
	30"	49"	<b>R3B0TLL4930( ) ( )</b>	1,091.
	36"	49"	<b>R3B0TLL4936( ) ( )</b>	1,179.
	42"	49"	<b>R3B0TLL4942( ) ( )</b>	1,214.
	48"	49"	<b>R3B0TLL4948( ) ( )</b>	1,250.

### Order Code

Example:	<b>R3B0TLL4918-A4K</b>
<b>R3</b>	Reff Generation 3
<b>B0</b>	No Beltway
<b>T</b>	Tiled panel
<b>LL</b>	Laminate both sides
<b>49</b>	49" high
<b>18</b>	18" wide
<b>A</b>	Flat style top trim profile
<b>4</b>	4" base height
<b>K</b>	Include knockouts in base
<b>B</b>	Tile divider, black reveal
<b>118</b>	Laminate - side 1A
<b>118</b>	Laminate - side 1B
<b>118</b>	Laminate - side 1C
<b>118</b>	Laminate - side 2A
<b>118</b>	Laminate - side 2B
<b>118</b>	Laminate - side 2C
<b>V512</b>	Figured Anigre (top trim finish)
<b>111</b>	Jet Black (base finish)
<b>M</b>	Optional milled frame

### Specification Information

*To order please specify pattern number including:*

1. Top trim profile
2. Base height
3. Knockout option  
(K = with knockouts, N = without knockouts)
4. Tile divider  
B = black steel divider or specify AA-anodized aluminum or painted option excluding silver from page 5 for extruded aluminum divider (upcharge applicable for extruded aluminum divider)
5. Laminate side, finish (specify selection per insert)  
i) tile 1A bottom  
ii) tile 1B middle  
iii) tile 1C top
6. Laminate, finish
7. Top trim finish  
i) Profile A, B or C options: V1, V2, V3, P1, P2, P3 finishes  
ii) Profile E options: AA-anodized aluminum or painted finish from page 5 excluding silver
8. Base finish
9. *Optional non-beltway panels:* specify (M) for panel frame to be milled for ported components, \$14 list upcharge applicable

### Application Notes

1. *Top trim profile:*  
A = Flat  
B = Square  
C = Bullnose  
E = Extruded Aluminum
2. *Base height:*  
4 = 4" base height

4. *Extruded aluminum tile divider: Optional for non fabric side only* (fabric side always black)  
49"h add per panel:  
\$25 for 18w and 20w  
\$28 for 24w and 30w  
\$34 for 36w and 42w  
\$42 for 48w

Applicable finishes are listed on page 5 and 6.

Product on this page will accept wood grain laminate where laminate is currently an option. Panel product is subject to a 10% upcharge on the base panel price. Refer to panel product upcharge table.

The panels on this page will accept stacking modules to increase their height on 18" to 48"W panels only. The 60" to 72"W panels will not accept stacking modules on top of themselves.

Product on this page can be attached to posts 49", 64", and 79"H as well as panels 42", 49", 64" and 79"H. Panels on this page will not attach to panels made before April 1997 without an attachment kit from page 117.

Remember to specify Beltway paint finish when applicable.

79"H hookstrip reveal strips are ordered separately from page 117 at no charge.

# Tiled panels 64" H fabric both sides

description	w	h	pattern no.	grade						
				10	15	20	30	35	40	45
Tiled, fabric both sides	18"	64"	<b>R3B0TFF64 18-()</b> ( )	\$828.	\$884.	\$1,004.	\$1,132.	\$1,244.	\$1,412.	\$1,516.
Regular acoustics	20"	64"	<b>R3B0TFF64 20-()</b> ( )	828.	884.	1,004.	1,132.	1,244.	1,412.	1,516.
	24"	64"	<b>R3B0TFF64 24-()</b> ( )	887.	943.	1,063.	1,191.	1,303.	1,471.	1,575.
	30"	64"	<b>R3B0TFF64 30-()</b> ( )	952.	1,008.	1,128.	1,256.	1,368.	1,536.	1,640.
	36"	64"	<b>R3B0TFF64 36-()</b> ( )	1,008.	1,064.	1,184.	1,312.	1,424.	1,592.	1,696.
	42"	64"	<b>R3B0TFF64 42-()</b> ( )	1,152.	1,208.	1,324.	1,456.	1,568.	1,736.	1,840.
	48"	64"	<b>R3B0TFF64 48-()</b> ( )	1,210.	1,266.	1,386.	1,514.	1,626.	1,794.	1,898.

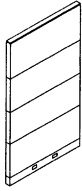

Tiled, fabric both sides	18"	64"	<b>R3B0TAA64 18-()</b> ( )	906.	962.	1,082.	1,210.	1,322.	1,490.	1,594.
High acoustics	20"	64"	<b>R3B0TAA64 20-()</b> ( )	906.	962.	1,082.	1,210.	1,322.	1,490.	1,594.
	24"	64"	<b>R3B0TAA64 24-()</b> ( )	971.	1,027.	1,147.	1,275.	1,387.	1,555.	1,659.
	30"	64"	<b>R3B0TAA64 30-()</b> ( )	1,044.	1,100.	1,220.	1,348.	1,460.	1,628.	1,732.
	36"	64"	<b>R3B0TAA64 36-()</b> ( )	1,112.	1,168.	1,288.	1,416.	1,528.	1,696.	1,800.
	42"	64"	<b>R3B0TAA64 42-()</b> ( )	1,266.	1,322.	1,442.	1,570.	1,682.	1,850.	1,954.
	48"	64"	<b>R3B0TAA64 48-()</b> ( )	1,334.	1,390.	1,510.	1,638.	1,750.	1,918.	2,022.

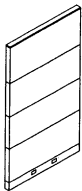

Order Code	Specification Information	Application Notes
Example: <b>R3B0TFF6418-A4K</b>	<i>To order please specify pattern number including:</i>	<i>1. Top trim profile:</i>
<b>R3</b> Reff Generation 3	1. Top trim profile	A = Flat
<b>B0</b> No Beltway	2. Base height	B = Square
<b>T</b> Tiled panel	3. Knockout option	C = Bullnose
<b>FF</b> Fabric on both sides	(K = with knockouts, N = without knockouts)	E = Extruded Aluminum
<b>64</b> 64" high	4. Fabric side, finish (specify selection per insert)	<i>2. Base height:</i>
<b>18</b> 18" wide	i) tile 1A bottom	4 = 4" base height
<b>A</b> Flat style top trim profile	ii) tile 1B middle	6 = 6" base height (add \$47 per panel for this option)
<b>4</b> 4" base height	iii) tile 1C middle	6" Raceway option increases panel height by 2 3/4".
<b>K</b> Include knockouts in base	iv) tile 1D top	Note: Extruded aluminum reveal/tile dividers are not optional for between fabric inserts.
<b>W281</b> Fabric - Side 1A	5. Fabric side, finish (specify selection per insert)	Applicable finishes are listed on page 5 and 6.
<b>W281</b> Fabric - Side 1B	i) tile 2A bottom	
<b>W281</b> Fabric - Side 1C	ii) tile 2B middle	
<b>W281</b> Fabric - Side 2A	iii) tile 2C middle	
<b>W281</b> Fabric - Side 2B	iv) tile 2D top	
<b>W281</b> Fabric - Side 2C	6. Top trim finish	
<b>V316</b> Maple (top trim finish)	i) Top trim profile A,B or C options:	
<b>111</b> Jet Black (base finish)	V1, V2, V3, P1, P2, P3 finishes	
<b>M</b> Optional milled frame	ii) Top trim profile E options: AA-anodized aluminum or P1, P2, P3 finish listed on page 5 excluding silver	
	7. Base finish	
	8. <i>Optional:</i> specify (M) for panel frame to be milled for ported components. \$14 list upcharge applicable	

The panels on this page will accept stacking modules to increase their height on 18" to 48"W panels only. The 60" to 72"W panels will not accept stacking modules on top of themselves.

Product on this page can be attached to posts 64", and 79"H as well as panels 42", 49", 64" and 79"H. Panels on this page will not attach to panels made before April 1997 without an attachment kit from page 117.

Remember to specify Beltway paint finish when applicable.

79"H hookstrip reveal strips are ordered separately from page 117 at no charge.

# Tiled panels 64" H

*fabric both sides, with Beltway*

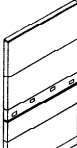
description	w	h	pattern no.	grade						
				10	15	20	30	35	40	45
Tiled, fabric both sides	18"	64"	<b>R3B1TFF64 18-</b> ( ) ( )	\$1,291.	\$1,347.	\$1,464.	\$1,595.	\$1,707.	\$1,875.	\$1,979.
Beltway one side	20"	64"	<b>R3B1TFF64 20-</b> ( ) ( )	1,291.	1,347.	1,464.	1,595.	1,707.	1,875.	1,979.
	24"	64"	<b>R3B1TFF64 24-</b> ( ) ( )	1,357.	1,413.	1,530.	1,661.	1,773.	1,941.	2,045.
	30"	64"	<b>R3B1TFF64 30-</b> ( ) ( )	1,390.	1,446.	1,563.	1,694.	1,806.	1,974.	2,078.
	36"	64"	<b>R3B1TFF64 36-</b> ( ) ( )	1,707.	1,763.	1,880.	2,011.	2,123.	2,291.	2,395.
	42"	64"	<b>R3B1TFF64 42-</b> ( ) ( )	1,833.	1,889.	2,006.	2,137.	2,249.	2,417.	2,521.
	48"	64"	<b>R3B1TFF64 48-</b> ( ) ( )	1,898.	1,954.	2,071.	2,202.	2,314.	2,482.	2,586.

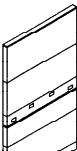
Tiled, fabric both sides	18"	64"	<b>R3B2TFF64 18-</b> ( ) ( )	1,311.	1,367.	1,481.	1,615.	1,727.	1,895.	1,999.
Beltway two sides	20"	64"	<b>R3B2TFF64 20-</b> ( ) ( )	1,311.	1,367.	1,481.	1,615.	1,727.	1,895.	1,999.
	24"	64"	<b>R3B2TFF64 24-</b> ( ) ( )	1,378.	1,434.	1,548.	1,682.	1,794.	1,962.	2,066.
	30"	64"	<b>R3B2TFF64 30-</b> ( ) ( )	1,412.	1,468.	1,582.	1,716.	1,828.	1,996.	2,100.
	36"	64"	<b>R3B2TFF64 36-</b> ( ) ( )	1,737.	1,793.	1,907.	2,041.	2,153.	2,321.	2,425.
	42"	64"	<b>R3B2TFF64 42-</b> ( ) ( )	1,861.	1,917.	2,031.	2,165.	2,277.	2,445.	2,549.
	48"	64"	<b>R3B2TFF64 48-</b> ( ) ( )	1,931.	1,987.	2,101.	2,235.	2,347.	2,515.	2,619.

**Order Code**

**Specification Information**

**Application Notes**

Example: <b>R3B1TFF7918-A4K</b>	
<b>R3</b>	Reff Generation 3
<b>B1</b>	Beltway one side
<b>T</b>	Tiled panel
<b>FF</b>	Fabric on both sides
<b>79</b>	79" high
<b>18</b>	18" wide
<b>A</b>	Flat style top trim profile
<b>4</b>	4" base height
<b>K</b>	Include knockouts in base
<b>W281</b>	Fabric - Side 1A
<b>W281</b>	Fabric - Side 1B
<b>W281</b>	Fabric - Side 1C
<b>W281</b>	Fabric - Side 1D
<b>W281</b>	Fabric - Side 2A
<b>W281</b>	Fabric - Side 2B
<b>W281</b>	Fabric - Side 2C
<b>W281</b>	Fabric - Side 2D
<b>V316</b>	Maple (top trim finish)
<b>111</b>	Jet Black (base finish)
<b>111</b>	Beltway finish

*To order please specify pattern number including:*

1. Top trim profile
2. Base height
3. Knockout option (K = with knockouts, N = without knockouts)
4. Fabric side, finish (specify selection per insert)
  - i) tile 1A bottom
  - ii) tile 1B middle
  - iii) tile 1C middle
  - iv) tile 1D middle
5. Fabric side, finish (specify selection per insert)
  - i) tile 2A bottom
  - ii) tile 2B middle
  - iii) tile 2C middle
  - iv) tile 2D middle

6. Top trim finish
  - i) Top trim profile A,B or C options: V1, V2, V3, P1, P2, P3 finishes
  - ii) Top trim profile E options: AA-anodized aluminum or P1, P2, P3 finish listed on page 5 excluding silver
7. Base finish
8. Beltway finish
  1. *Top trim profile:*  
A = Flat  
B = Square  
C = Bullnose  
E = Extruded Aluminum
  2. *Base height:*  
4 = 4" base height  
6 = 6" base height (add \$47 per panel for this option)

Note: Extruded aluminum reveal/tile dividers are not optional for between fabric inserts.

Applicable finishes are listed on page 5 and 6.

The panels on this page will not accept stacking modules.

6" Raceway option increases panel height by  $2\frac{3}{4}"$ .

Product on this page can be attached to posts 79"H as well as panels 42", 49", 64" and 79"H . Panels on this page will not attach to panels made before April 1997 without an attachment kit from page 117.

Remember to specify Beltway paint finish when applicable.

79"H hookstrip reveal strips are ordered separately from page 117 at no charge.



# Tiled panels 64" H

*fabric one side, laminate other side*

description	w	h	pattern no.	grade						
				10	15	20	30	35	40	45
Tiled, fabric one side	18"	64"	<b>R3B0TFL64 18-( ) ( )</b>	\$917.	\$945.	\$1,001.	\$1,065.	\$1,121.	\$1,197.	\$1,249.
Regular acoustics	20"	64"	<b>R3B0TFL64 20-( ) ( )</b>	917.	945.	1,001.	1,065.	1,121.	1,197.	1,249.
	24"	64"	<b>R3B0TFL64 24-( ) ( )</b>	972.	1,000.	1,056.	1,120.	1,176.	1,252.	1,304.
	30"	64"	<b>R3B0TFL64 30-( ) ( )</b>	1,037.	1,065.	1,121.	1,185.	1,241.	1,317.	1,369.
	36"	64"	<b>R3B0TFL64 36-( ) ( )</b>	1,095.	1,123.	1,179.	1,243.	1,299.	1,375.	1,427.
	42"	64"	<b>R3B0TFL64 42-( ) ( )</b>	1,231.	1,259.	1,315.	1,379.	1,435.	1,511.	1,563.
	48"	64"	<b>R3B0TFL64 48-( ) ( )</b>	1,289.	1,317.	1,373.	1,437.	1,493.	1,569.	1,621.

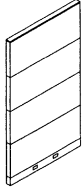

Tiled, fabric one side	18"	64"	<b>R3B1TFL64 18-( ) ( )</b>	1,363.	1,391.	1,446.	1,511.	1,567.	1,643.	1,695.
Beltway one side (fabric side)	20"	64"	<b>R3B1TFL64 20-( ) ( )</b>	1,363.	1,391.	1,446.	1,511.	1,567.	1,643.	1,695.
	24"	64"	<b>R3B1TFL64 24-( ) ( )</b>	1,429.	1,457.	1,512.	1,577.	1,633.	1,709.	1,761.
	30"	64"	<b>R3B1TFL64 30-( ) ( )</b>	1,459.	1,487.	1,542.	1,607.	1,663.	1,739.	1,791.
	36"	64"	<b>R3B1TFL64 36-( ) ( )</b>	1,770.	1,798.	1,853.	1,918.	1,974.	2,050.	2,102.
	42"	64"	<b>R3B1TFL64 42-( ) ( )</b>	1,887.	1,915.	1,970.	2,035.	2,091.	2,167.	2,219.
	48"	64"	<b>R3B1TFL64 48-( ) ( )</b>	1,950.	1,978.	2,033.	2,098.	2,154.	2,230.	2,282.

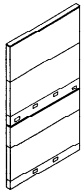

Order Code	Specification Information	Application Notes
Example: <b>R3B0TFL6418-A4K</b>	<i>To order please specify pattern number including:</i>	The panels on this page will accept stacking modules to increase their height on 18" to 48"W panels only. The 60" to 72"W panels will not accept stacking modules on top of themselves.
<b>R3</b> Reff Generation 3	8. Base finish	Product on this page can be attached to posts 64", and 79"H as well as panels 42", 49", 64" and 79"H. Panels on this page will not attach to panels made before April 1997 without an attachment kit from page 117.
<b>B0</b> No Beltway	9. Beltway finish, for panels with Beltway	
<b>T</b> Tiled panel	10. <i>Optional non-beltway panels:</i> specify (M) for panel frame to be milled for ported components, \$14 list upcharge applicable	
<b>FL</b> Fabric one side, laminate other	1. <i>Top trim profile:</i> A = Flat B = Square C = Bullnose E = Extruded Aluminum	
<b>64</b> 64" high	2. <i>Base height:</i> 4 = 4" base height 6 = 6" base height (add \$47 per panel for this option)	
<b>18</b> 18" wide	4. <i>Extruded aluminum tile divider:</i> <b>Optional for non fabric side only</b> (fabric side always black) 64"h add per panel: \$39 for 18w and 20w \$43 for 24w and 30w \$48 for 36w and 42w \$64 for 48w	
<b>A</b> Flat style top trim profile	6" Raceway option increases panel height by 2 3/4".	
<b>4</b> 4" base height	Applicable finishes are listed on page 5 and 6.	
<b>K</b> Include knockouts in base	Product on this page excluding Beltway panels will accept wood grain laminate where laminate is currently an option. Panel product is subject to a 10% upcharge on the base panel price. Refer to panel product upcharge table.	
<b>B</b> Tile divider, black reveal		
<b>W281</b> Fabric - Side 1A	1. Top trim profile	
<b>W281</b> Fabric - Side 1B	2. Base height	
<b>W281</b> Fabric - Side 1C	3. Knockout option (K = with knockouts, N = without knockouts)	
<b>114</b> Folkstone grey - side 2A	4. Tile divider B = black steel divider or specify AA-anodized aluminum or painted option excluding silver from page 5 for extruded aluminum divider (upcharge applicable for extruded aluminum divider)	
<b>114</b> Folkstone grey - side 2B	5. Fabric side, finish (specify selection per insert) i) tile 1A bottom ii) tile 1B middle iii) tile 1C middle iv) tile 1D top	
<b>114</b> Folkstone grey - side 2C	6. Laminate side, finish (specify selection per insert) i) tile 2A bottom ii) tile 2B middle iii) tile 2C middle iv) tile 2D top	
<b>V316</b> Maple (top trim finish)	7. Top trim finish i) Profile A, B or C options: V1, V2, V3, P1, P2, P3 finishes ii) Profile E options: AA-anodized aluminum or painted finish from page 5 excluding silver	
<b>111</b> Jet Black (base finish)		
<b>M</b> Optional milled frame		

# Tiled panels 64" H

*fabric one side, techwood other side*

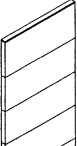
description	w	h	pattern no.	grade						
				10	15	20	30	35	40	45
Tiled, fabric one side	18"	64"	<b>R3B0TF164 18-()</b> ( )	\$985.	\$1,013.	\$1,077.	\$1,141.	\$1,197.	\$1,281.	\$1,333.
Regular acoustics	20"	64"	<b>R3B0TF164 20-()</b> ( )	985.	1,013.	1,077.	1,141.	1,197.	1,281.	1,333.
	24"	64"	<b>R3B0TF164 24-()</b> ( )	1,045.	1,073.	1,137.	1,201.	1,257.	1,341.	1,393.
	30"	64"	<b>R3B0TF164 30-()</b> ( )	1,114.	1,142.	1,206.	1,270.	1,326.	1,410.	1,462.
	36"	64"	<b>R3B0TF164 36-()</b> ( )	1,175.	1,203.	1,267.	1,331.	1,387.	1,471.	1,523.
	42"	64"	<b>R3B0TF164 42-()</b> ( )	1,323.	1,351.	1,415.	1,479.	1,535.	1,619.	1,671.
	48"	64"	<b>R3B0TF164 48-()</b> ( )	1,384.	1,412.	1,476.	1,540.	1,596.	1,680.	1,732.

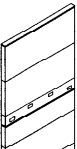
Tiled, fabric one side	18"	64"	<b>R3B1TF164 18-()</b> ( )	1,464.	1,492.	1,556.	1,620.	1,676.	1,760.	1,812.
Beltway one side (fabric side)	20"	64"	<b>R3B1TF164 20-()</b> ( )	1,464.	1,492.	1,556.	1,620.	1,676.	1,760.	1,812.
	24"	64"	<b>R3B1TF164 24-()</b> ( )	1,535.	1,563.	1,627.	1,691.	1,747.	1,831.	1,883.
	30"	64"	<b>R3B1TF164 30-()</b> ( )	1,568.	1,596.	1,660.	1,724.	1,780.	1,864.	1,916.
	36"	64"	<b>R3B1TF164 36-()</b> ( )	1,900.	1,928.	1,992.	2,056.	2,112.	2,196.	2,248.
	42"	64"	<b>R3B1TF164 42-()</b> ( )	2,027.	2,055.	2,119.	2,183.	2,239.	2,323.	2,375.
	48"	64"	<b>R3B1TF164 48-()</b> ( )	2,100.	2,128.	2,192.	2,256.	2,312.	2,396.	2,448.

Order Code	Specification Information	Application Notes
Example: <b>R3B0TF16418-A4K</b>	<i>To order please specify pattern number including:</i>	<i>1. Top trim profile:</i>
<b>R3</b> Reff Generation 3	1. Top trim profile	A = Flat
<b>B0</b> No Beltway	2. Base height	B = Square
<b>T</b> Tiled panel	3. Knockout option	C = Bullnose
<b>F1</b> Fabric one side, V1 other	(K = with knockouts, N = without knockouts)	E = Extruded Aluminum
<b>64</b> 64" high	4. Tile divider	<i>2. Base height:</i>
<b>18</b> 18" wide	B = black steel divider or specify	4 = 4" base height
<b>A</b> Flat style top trim profile	AA-anodized aluminum or painted option excluding silver	6 = 6" base height (add \$47 per panel for this option)
<b>4</b> 4" base height	from page 5 for extruded aluminum divider (upcharge applicable for extruded aluminum divider)	<i>4. Extruded aluminum tile divider:</i>
<b>K</b> Include knockouts in base	5. Fabric side, finish (specify selection per insert)	<b>Optional for non fabric side only</b>
<b>B</b> Tile divider, black reveal	i) tile 1A bottom	(fabric side always black)
<b>W281</b> Fabric - Side 1A	ii) tile 1B middle	64"h add per panel:
<b>W281</b> Fabric - Side 1B	iii) tile 1C middle	\$39 for 18w and 20w
<b>W281</b> Fabric - Side 1C	iv) tile 1D top	\$43 for 24w and 30w
<b>Y328</b> Mahogany - side 2 tiled	6. Techwood side, finish (specify one V1 finish for side)	\$48 for 36w and 42w
<b>V316</b> Maple (top trim finish)	7. Top trim finish	\$64 for 48w
<b>111</b> Jet Black (base finish)	i) Profile A, B or C options: V1, V2, V3, P1, P2, P3 finishes	<i>6" Raceway option increases panel height by 2 3/4".</i>
<b>M</b> Optional milled frame	ii) Profile E options: AA-anodized aluminum or painted finish from page 5 excluding silver	Applicable finishes are listed on page 5 and 6.
	8. Base finish	
	9. Beltway finish, for panels with Beltway	
	10. <i>Optional non-beltway panels:</i> specify (M) for panel frame to be milled for ported components, \$14 list upcharge applicable	

The panels on this page will accept stacking modules to increase their height on 18" to 48"W panels only. The 60" to 72"W panels will not accept stacking modules on top of themselves.

Product on this page can be attached to posts 64", and 79"H as well as panels 42", 49", 64" and 79"H. Panels on this page will not attach to panels made before April 1997 without an attachment kit from page 117.

Remember to specify Beltway paint finish when applicable.

79"H hookstrip reveal strips are ordered separately from page 117 at no charge.

# Tiled panels 64" H

*fabric one side, conventional veneer other side*

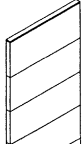
description	w	h	pattern no.	grade						
				10	15	20	30	35	40	45
Tiled, fabric one side	18"	64"	<b>R3B0TF264 18-</b> ( ) ( )	\$1,004.	\$1,032.	\$1,096.	\$1,160.	\$1,216.	\$1,300.	\$1,352.
Regular acoustics	20"	64"	<b>R3B0TF264 20-</b> ( ) ( )	1,004.	1,032.	1,096.	1,160.	1,216.	1,300.	1,352.
	24"	64"	<b>R3B0TF264 24-</b> ( ) ( )	1,062.	1,090.	1,154.	1,218.	1,274.	1,358.	1,410.
	30"	64"	<b>R3B0TF264 30-</b> ( ) ( )	1,131.	1,159.	1,223.	1,287.	1,343.	1,427.	1,479.
	36"	64"	<b>R3B0TF264 36-</b> ( ) ( )	1,196.	1,224.	1,288.	1,352.	1,408.	1,492.	1,544.
	42"	64"	<b>R3B0TF264 42-</b> ( ) ( )	1,346.	1,374.	1,438.	1,502.	1,558.	1,642.	1,694.
	48"	64"	<b>R3B0TF264 48-</b> ( ) ( )	1,409.	1,437.	1,501.	1,565.	1,621.	1,705.	1,757.

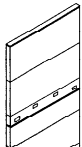
Tiled, fabric one side	18"	64"	<b>R3B1TF264 18-</b> ( ) ( )	1,491.	1,519.	1,583.	1,647.	1,703.	1,787.	1,839.
Beltway one side (fabric side)	20"	64"	<b>R3B1TF264 20-</b> ( ) ( )	1,491.	1,519.	1,583.	1,647.	1,703.	1,787.	1,839.
	24"	64"	<b>R3B1TF264 24-</b> ( ) ( )	1,563.	1,591.	1,655.	1,719.	1,775.	1,859.	1,911.
	30"	64"	<b>R3B1TF264 30-</b> ( ) ( )	1,596.	1,624.	1,688.	1,752.	1,808.	1,892.	1,944.
	36"	64"	<b>R3B1TF264 36-</b> ( ) ( )	1,937.	1,965.	2,029.	2,093.	2,149.	2,233.	2,285.
	42"	64"	<b>R3B1TF264 42-</b> ( ) ( )	2,066.	2,094.	2,158.	2,222.	2,278.	2,362.	2,414.
	48"	64"	<b>R3B1TF264 48-</b> ( ) ( )	2,131.	2,159.	2,223.	2,287.	2,343.	2,427.	2,479.

Order Code	Specification Information	Application Notes
Example: <b>R3B0TF26418-A4K</b>	<i>To order please specify pattern number including:</i>	<i>1. Top trim profile:</i>
<b>R3</b> Reff Generation 3	1. Top trim profile	A = Flat
<b>B0</b> No Beltway	2. Base height	B = Square
<b>T</b> Tiled panel	3. Knockout option	C = Bullnose
<b>F2</b> Fabric one side, V2 other	(K = with knockouts, N = without knockouts)	E = Extruded Aluminum
<b>64</b> 64" high	4. Tile divider	<i>2. Base height:</i>
<b>18</b> 18" wide	B = black steel divider or specify	4 = 4" base height
<b>A</b> Flat style top trim profile	AA-anodized aluminum or	6 = 6" base height (add \$47 per panel for this option)
<b>4</b> 4" base height	painted option excluding silver	6" raceway option increases panel height by 2 3/4".
<b>K</b> Include knockouts in base	from page 5 for extruded aluminum divider (upcharge applicable for extruded aluminum divider)	<i>4. Extruded aluminum tile divider: Optional for non fabric side only (fabric side always black)</i>
<b>B</b> Tile divider, black reveal	5. Fabric side, finish (specify selection per insert)	64" h add per panel:
<b>W281</b> Fabric - Side 1A	i) tile 1A bottom	\$39 for 18w and 20w
<b>W281</b> Fabric - Side 1B	ii) tile 1B middle	\$43 for 24w and 30w
<b>W281</b> Fabric - Side 1C	iii) tile 1C middle	\$48 for 36w and 42w
<b>W281</b> Fabric - Side 1D	iv) tile 1D top	\$64 for 48w
<b>V316</b> Maple surface - side 2 tiled	6. Conventional veneer, finish (specify one V2 finish for side)	Applicable finishes are listed on page 5 and 6.
<b>V316</b> Maple (top trim finish)	7. Top trim finish	
<b>111</b> Jet Black (base finish)	i) Profile A, B or C options: V1, V2, V3, P1, P2, P3 finishes	
<b>M</b> Optional milled frame	ii) Profile E options: AA-anodized aluminum or painted finish from page 5 excluding silver	
	8. Base finish	
	9. Beltway finish, for panels with Beltway	
	10. <i>Optional non-beltway panels:</i> specify (M) for panel frame to be milled for ported components, \$14 list upcharge applicable	

# Tiled panels 64" H

*fabric one side, exotic veneer other side*

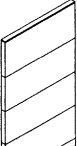
description	w	h	pattern no.	grade						
				10	15	20	30	35	40	45
Tiled, fabric one side	18"	64"	<b>R3B0TF364 18-()</b> ( )	\$1,333.	\$1,361.	\$1,425.	\$1,489.	\$1,545.	\$1,629.	\$1,681.
Regular acoustics	20"	64"	<b>R3B0TF364 20-()</b> ( )	1,333.	1,361.	1,425.	1,489.	1,545.	1,629.	1,681.
	24"	64"	<b>R3B0TF364 24-()</b> ( )	1,411.	1,439.	1,502.	1,568.	1,622.	1,706.	1,760.
	30"	64"	<b>R3B0TF364 30-()</b> ( )	1,504.	1,532.	1,596.	1,660.	1,716.	1,800.	1,852.
	36"	64"	<b>R3B0TF364 36-()</b> ( )	1,593.	1,621.	1,685.	1,749.	1,805.	1,889.	1,941.
	42"	64"	<b>R3B0TF364 42-()</b> ( )	1,795.	1,823.	1,887.	1,951.	2,007.	2,091.	2,143.
	48"	64"	<b>R3B0TF364 48-()</b> ( )	1,879.	1,907.	1,971.	2,035.	2,091.	2,175.	2,227.

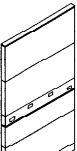
Tiled, fabric one side	18"	64"	<b>R3B1TF364 18-()</b> ( )	1,991.	2,019.	2,083.	2,147.	2,203.	2,287.	2,339.
Beltway fabric side	20"	64"	<b>R3B1TF364 20-()</b> ( )	1,991.	2,019.	2,083.	2,147.	2,203.	2,287.	2,339.
	24"	64"	<b>R3B1TF364 24-()</b> ( )	2,090.	2,118.	2,182.	2,246.	2,302.	2,386.	2,438.
	30"	64"	<b>R3B1TF364 30-()</b> ( )	2,131.	2,159.	2,223.	2,287.	2,343.	2,427.	2,479.
	36"	64"	<b>R3B1TF364 36-()</b> ( )	2,592.	2,620.	2,684.	2,748.	2,804.	2,888.	2,940.
	42"	64"	<b>R3B1TF364 42-()</b> ( )	2,766.	2,794.	2,858.	2,922.	2,978.	3,062.	3,114.
	48"	64"	<b>R3B1TF364 48-()</b> ( )	2,857.	2,885.	2,949.	3,013.	3,069.	3,153.	3,205.

## Order Code

Example:	<b>R3B0TF36418-A4K</b>
<b>R3</b>	Reff Generation 3
<b>B0</b>	No Beltway
<b>T</b>	Tiled panel
<b>F3</b>	Fabric one side, V3 other
<b>64</b>	64" high
<b>18</b>	18" wide
<b>A</b>	Flat style top trim profile
<b>4</b>	4" base height
<b>K</b>	Include knockouts in base
<b>B</b>	Tile divider, black reveal
<b>W281</b>	Fabric - Side 1A
<b>W281</b>	Fabric - Side 1B
<b>W281</b>	Fabric - Side 1C
<b>W281</b>	Fabric - Side 1D
<b>V512</b>	Figured Anigre surface - side 2 tiled
<b>V512</b>	Figured Anigre (top trim finish)
<b>111</b>	Jet Black (base finish)
<b>M</b>	Optional milled frame

## Specification Information

- To order please specify pattern number including:*
- Top trim profile
  - Base height
  - Knockout option (K = with knockouts, N = without knockouts)
  - Tile divider  
B = black steel divider or specify AA-anodized aluminum or painted option excluding silver from page 5 for extruded aluminum divider (upcharge applicable for extruded aluminum divider)
  - Fabric side, finish (specify selection per insert)  
*i*) tile 1A bottom  
*ii*) tile 1B middle  
*iii*) tile 1C middle  
*iv*) tile 1D top
  - Exotic veneer, finish (specify one V3 finish for side)
  - Top trim finish  
*i*) Profile A, B or C options: V1, V2, V3, P1, P2, P3 finishes  
*ii*) Profile E options: AA-anodized aluminum or painted finish from page 5 excluding silver
  - Base finish
  - Beltway finish, for panels with Beltway
  - Optional non-beltway panels:* specify (M) for panel frame to be milled for ported components, \$14 list upcharge applicable

## Application Notes

- Top trim profile:*  
A = Flat  
B = Square  
C = Bullnose  
E = Extruded Aluminum

- Base height:*  
4 = 4" base height  
6 = 6" base height (add \$47 per panel for this option)

6" raceway option increases panel height by 2 3/4".

- Extruded aluminum tile divider: Optional for non fabric side only (fabric side always black)*  
64"h add per panel:  
\$39 for 18w and 20w  
\$43 for 24w and 30w  
\$48 for 36w and 42w  
\$64 for 48w

Applicable finishes are listed on page 5 and 6.

The panels on this page will accept stacking modules to increase their height on 18" to 48"W panels only. The 60" to 72"W panels will not accept stacking modules on top of themselves.

Product on this page can be attached to posts 64", and 79"H as well as panels 42", 49", 64" and 79"H. Panels on this page will not attach to panels made before April 1997 without an attachment kit from page 117.

Remember to specify Beltway paint finish when applicable.

79"H hookstrip reveal strips are ordered separately from page 117 at no charge.

# Tiled panels 64" H

## Laminate/Laminate

description	w	h	pattern no.	L
Tiled, laminate both sides	18"	64"	<b>R3B0TLL6418</b> ( ) ( )	\$1,112.
with raceway both sides	20"	64"	<b>R3B0TLL6420</b> ( ) ( )	1,112.
	24"	64"	<b>R3B0TLL6424</b> ( ) ( )	1,212.
	30"	64"	<b>R3B0TLL6430</b> ( ) ( )	1,358.
	36"	64"	<b>R3B0TLL6436</b> ( ) ( )	1,466.
	42"	64"	<b>R3B0TLL6442</b> ( ) ( )	1,510.
	48"	64"	<b>R3B0TLL6448</b> ( ) ( )	1,571.

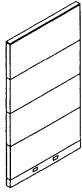

Order Code	Specification Information	Application Notes
Example: <b>R3B0TLL6418-A4K</b>	<i>To order please specify pattern number including:</i>	
<b>R3</b> Reff Generation 3	1. Top trim profile	1. <i>Top trim profile:</i> A = Flat B = Square C = Bullnose E = Extruded Aluminum
<b>B0</b> No Beltway	2. Base height	2. <i>Base height:</i> 4 = 4" base height
<b>T</b> Tiled panel	3. Knockout option (K = with knockouts, N = without knockouts)	4. <i>Extruded aluminum tile divider:</i> <b>Optional for non fabric side only</b> (fabric side always black) 64"h add per panel: \$39 for 18w and 20w \$43 for 24w and 30w \$48 for 36w and 42w \$64 for 48w
<b>LL</b> Laminate both sides	4. Tile divider B = black steel divider or specify AA-anodized aluminum or painted option excluding silver from page 5 for extruded aluminum divider (upcharge applicable for extruded aluminum divider)	Product on this page can be attached to posts 64", and 79"H as well as panels 42", 49", 64" and 79"H. Panels on this page will not attach to panels made before April 1997 without an attachment kit from page 117.
<b>64</b> 64" high	5. Laminate side, finish (specify selection per insert)	Remember to specify Beltway paint finish when applicable.
<b>18</b> 18" wide	i) tile 1A bottom	79"H hookstrip reveal strips are ordered separately from page 117 at no charge.
<b>A</b> Flat style top trim profile	ii) tile 1B middle	
<b>4</b> 4" base height	iii) tile 1C middle	
<b>K</b> Include knockouts in base	iv) tile 1D top	
<b>B</b> Tile divider, black reveal	6. Laminate, finish	Applicable finishes are listed on page 5 and 6.
<b>118</b> Laminate - side 1A	7. Top trim finish	Product on this page will accept wood grain laminate where laminate is currently an option. Panel product is subject to a 10% upcharge on the base panel price. Refer to panel product upcharge table.
<b>118</b> Laminate - side 1B	i) Profile A, B or C options: V1, V2, V3, P1, P2, P3 finishes	
<b>118</b> Laminate - side 1C	ii) Profile E options: AA-anodized aluminum or painted finish from page 5 excluding silver	
<b>118</b> Laminate - side 1D	8. Base finish	
<b>118</b> Laminate - side 2A	9. <i>Optional non-beltway panels:</i> specify (M) for panel frame to be milled for ported components, \$14 list upcharge applicable	
<b>118</b> Laminate - side 2B		
<b>118</b> Laminate - side 2C		
<b>118</b> Laminate - side 2D		
<b>V512</b> Figured Anigre (top trim finish)		
<b>111</b> Jet Black (base finish)		
<b>M</b> Optional milled frame		

# Tiled panels 79" H

## *fabric both sides*

description	w	h	pattern no.	grade						
				10	15	20	30	35	40	45
Tiled, fabric both sides	18"	79"	<b>R3B0TFF79 18-</b> ( ) ( )	\$1,030.	\$1,100.	\$1,250.	\$1,410.	\$1,550.	\$1,760.	\$1,890.
Regular acoustics	20"	79"	<b>R3B0TFF79 20-</b> ( ) ( )	1,030.	1,100.	1,250.	1,410.	1,550.	1,760.	1,890.
	24"	79"	<b>R3B0TFF79 24-</b> ( ) ( )	1,095.	1,165.	1,315.	1,475.	1,615.	1,825.	1,955.
	30"	79"	<b>R3B0TFF79 30-</b> ( ) ( )	1,158.	1,228.	1,378.	1,538.	1,678.	1,888.	2,018.
	36"	79"	<b>R3B0TFF79 36-</b> ( ) ( )	1,224.	1,294.	1,444.	1,604.	1,744.	1,954.	2,084.
	42"	79"	<b>R3B0TFF79 42-</b> ( ) ( )	1,390.	1,460.	1,610.	1,770.	1,910.	2,120.	2,250.
	48"	79"	<b>R3B0TFF79 48-</b> ( ) ( )	1,460.	1,530.	1,680.	1,840.	1,980.	2,190.	2,320.

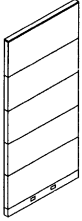

Tiled, fabric both sides	18"	79"	<b>R3B0TAA79 18-</b> ( ) ( )	1,126.	1,196.	1,346.	1,506.	1,646.	1,856.	1,986.
High acoustics	20"	79"	<b>R3B0TAA79 20-</b> ( ) ( )	1,126.	1,196.	1,346.	1,506.	1,646.	1,856.	1,986.
	24"	79"	<b>R3B0TAA79 24-</b> ( ) ( )	1,201.	1,271.	1,421.	1,581.	1,721.	1,931.	2,061.
	30"	79"	<b>R3B0TAA79 30-</b> ( ) ( )	1,270.	1,340.	1,490.	1,650.	1,790.	2,000.	2,130.
	36"	79"	<b>R3B0TAA79 36-</b> ( ) ( )	1,342.	1,412.	1,562.	1,722.	1,862.	2,072.	2,202.
	42"	79"	<b>R3B0TAA79 42-</b> ( ) ( )	1,526.	1,596.	1,746.	1,906.	2,046.	2,256.	2,386.
	48"	79"	<b>R3B0TAA79 48-</b> ( ) ( )	1,606.	1,676.	1,826.	1,986.	2,126.	2,336.	2,466.

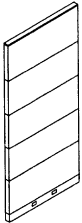

### Order Code

Example: <b>R3B0TFF7918-A4K</b>	
<b>R3</b>	Reff Generation 3
<b>B0</b>	No Beltway
<b>T</b>	Tiled panel
<b>FF</b>	Fabric on both sides
<b>79</b>	79" high
<b>18</b>	18" wide
<b>A</b>	Flat style top trim profile
<b>4</b>	4" base height
<b>K</b>	Include knockouts in base
<b>W281</b>	Fabric - Side 1A
<b>W281</b>	Fabric - Side 1B
<b>W281</b>	Fabric - Side 1C
<b>W281</b>	Fabric - Side 1D
<b>W281</b>	Fabric - Side 2A
<b>W281</b>	Fabric - Side 2B
<b>W281</b>	Fabric - Side 2C
<b>W281</b>	Fabric - Side 2D
<b>V316</b>	Maple (top trim finish)
<b>111</b>	Jet Black (base finish)
<b>M</b>	Optional milled frame

### Specification Information

*To order please specify pattern number including:*

1. Top trim profile
2. Base height
3. Knockout option (K = with knockouts, N = without knockouts)
4. Fabric side, finish (specify selection per insert)
  - i) tile 1A bottom
  - ii) tile 1B middle
  - iii) tile 1C middle
  - iv) tile 1D middle
  - v) tile 1E top
5. Fabric side, finish (specify selection per insert)
  - i) tile 2A bottom
  - ii) tile 2B middle
  - iii) tile 2C middle
  - iv) tile 2D middle
  - v) tile 2E top

6. Top trim finish
  - i) Top trim profile A, B or C options: V1, V2, V3, P1, P2, P3 finishes
  - ii) Top trim profile E options: AA-anodized aluminum or P1, P2, P3 finish listed on page 5 excluding silver
7. Base finish
  - 1. *Top trim profile:*  
A = Flat  
B = Square  
C = Bullnose  
E = Extruded Aluminum
  - 2. *Base height:*  
4 = 4" base height  
6 = 6" base height (add \$47 per panel for this option)

Note: Extruded aluminum reveal/tile dividers are not optional for between fabric inserts.

Applicable finishes are listed on page 5 and 6.

### Application Notes

The panels on this page will not accept stacking modules.

6" Raceway option increases panel height by 2<sup>3</sup>/<sub>4</sub>".

Product on this page can be attached to posts 79"H as well as panels 42", 49", 64" and 79"H. Panels on this page will not attach to panels made before April 1997 without an attachment kit from page 117.

Remember to specify Beltway paint finish when applicable.

79"H hookstrip reveal strips are ordered separately from page 117 at no charge.

# Tiled panels 79" H

*fabric both sides, with Beltway*

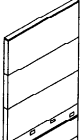
description	w	h	pattern no.	grade						
				10	15	20	30	35	40	45
Tiled, fabric both sides	18"	79"	<b>R3B1TFF79 18-( )()</b>	\$1,341.	\$1,411.	\$1,558.	\$1,721.	\$1,861.	\$2,071.	\$2,201.
Beltway one side	20"	79"	<b>R3B1TFF79 20-( )()</b>	1,341.	1,411.	1,558.	1,721.	1,861.	2,071.	2,201.
	24"	79"	<b>R3B1TFF79 24-( )()</b>	1,407.	1,477.	1,624.	1,787.	1,927.	2,137.	2,267.
	30"	79"	<b>R3B1TFF79 30-( )()</b>	1,439.	1,509.	1,656.	1,819.	1,959.	2,169.	2,299.
	36"	79"	<b>R3B1TFF79 36-( )()</b>	1,756.	1,826.	1,973.	2,136.	2,276.	2,486.	2,616.
	42"	79"	<b>R3B1TFF79 42-( )()</b>	1,884.	1,954.	2,101.	2,264.	2,404.	2,614.	2,744.
	48"	79"	<b>R3B1TFF79 48-( )()</b>	1,946.	2,016.	2,163.	2,326.	2,466.	2,676.	2,806.

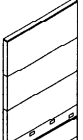
Tiled, fabric both sides	18"	79"	<b>R3B2TFF79 18-( )()</b>	1,359.	1,429.	1,573.	1,739.	1,879.	2,089.	2,219.
Beltway two sides	20"	79"	<b>R3B2TFF79 20-( )()</b>	1,359.	1,429.	1,573.	1,739.	1,879.	2,089.	2,219.
	24"	79"	<b>R3B2TFF79 24-( )()</b>	1,429.	1,499.	1,643.	1,809.	1,949.	2,159.	2,289.
	30"	79"	<b>R3B2TFF79 30-( )()</b>	1,459.	1,529.	1,673.	1,839.	1,979.	2,189.	2,319.
	36"	79"	<b>R3B2TFF79 36-( )()</b>	1,782.	1,852.	1,996.	2,162.	2,302.	2,512.	2,642.
	42"	79"	<b>R3B2TFF79 42-( )()</b>	1,912.	1,982.	2,126.	2,292.	2,432.	2,642.	2,772.
	48"	79"	<b>R3B2TFF79 48-( )()</b>	1,982.	2,052.	2,196.	2,362.	2,502.	2,712.	2,842.

Order Code	Specification Information	Application Notes
Example: <b>R3B1TFF7918-A4K</b>	<i>To order please specify pattern number including:</i>	
<b>R3</b>	1. Top trim profile	6. Top trim finish
<b>B1</b>	2. Base height	i) Top trim profile A, B or C options: V1, V2, V3, P1, P2, P3 finishes
<b>T</b>	3. Knockout option (K = with knockouts, N = without knockouts)	ii) Top trim profile E options: AA-anodized aluminum or P1, P2, P3 finish listed on page 5 excluding silver
<b>FF</b>	4. Fabric side, finish (specify selection per insert)	7. Base finish
<b>79</b>	i) tile 1A bottom	8. Beltway finish
<b>18</b>	ii) tile 1B middle	1. <i>Top trim profile:</i>
<b>A</b>	iii) tile 1C middle	A = Flat
<b>4</b>	iv) tile 1D middle	B = Square
<b>K</b>	v) tile 1E top	C = Bullnose
<b>W281</b>	5. Fabric side, finish (specify selection per insert)	E = Extruded Aluminum
<b>W281</b>	i) tile 2A bottom	
<b>W281</b>	ii) tile 2B middle	2. <i>Base height:</i>
<b>W281</b>	iii) tile 2C middle	4 = 4" base height
<b>W281</b>	iv) tile 2D middle	6 = 6" base height (add \$47 per panel for this option)
<b>W281</b>	v) tile 2E top	Note: Extruded aluminum reveal/tile dividers are not optional for between fabric inserts.
<b>W281</b>		Applicable finishes are listed on page 5 and 6.
<b>W281</b>		
<b>W281</b>		
<b>W281</b>		
<b>W281</b>		
<b>W281</b>		
<b>W281</b>		
<b>W281</b>		
<b>W281</b>		
<b>V316</b>	Maple (top trim finish)	
<b>111</b>	Jet Black (base finish)	
<b>111</b>	Beltway finish	

# Tiled panels 79" H

*fabric one side, laminate other side*

description	w	h	pattern no.	grade						
				10	15	20	30	35	40	45
Tiled, fabric one side	18"	79"	<b>R3B0TFL79 18-()</b> ( )	\$1,139.	\$1,174.	\$1,244.	\$1,324.	\$1,394.	\$1,489.	\$1,554.
Regular acoustics	20"	79"	<b>R3B0TFL79 20-()</b> ( )	1,139.	1,174.	1,244.	1,324.	1,394.	1,489.	1,554.
	24"	79"	<b>R3B0TFL79 24-()</b> ( )	1,208.	1,243.	1,313.	1,393.	1,463.	1,558.	1,623.
	30"	79"	<b>R3B0TFL79 30-()</b> ( )	1,266.	1,301.	1,371.	1,451.	1,521.	1,616.	1,681.
	36"	79"	<b>R3B0TFL79 36-()</b> ( )	1,329.	1,364.	1,434.	1,514.	1,584.	1,679.	1,744.
	42"	79"	<b>R3B0TFL79 42-()</b> ( )	1,489.	1,524.	1,594.	1,674.	1,744.	1,839.	1,904.
	48"	79"	<b>R3B0TFL79 48-()</b> ( )	1,558.	1,593.	1,663.	1,743.	1,813.	1,908.	1,973.

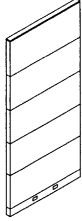

Tiled, fabric one side	18"	79"	<b>R3B1TFL79 18-()</b> ( )	1,440.	1,475.	1,544.	1,625.	1,695.	1,790.	1,855.
Beltway one side (fabric side)	20"	79"	<b>R3B1TFL79 20-()</b> ( )	1,440.	1,475.	1,544.	1,625.	1,695.	1,790.	1,855.
	24"	79"	<b>R3B1TFL79 24-()</b> ( )	1,505.	1,540.	1,609.	1,690.	1,760.	1,855.	1,920.
	30"	79"	<b>R3B1TFL79 30-()</b> ( )	1,538.	1,573.	1,642.	1,723.	1,793.	1,888.	1,953.
	36"	79"	<b>R3B1TFL79 36-()</b> ( )	1,846.	1,881.	1,950.	2,031.	2,101.	2,196.	2,261.
	42"	79"	<b>R3B1TFL79 42-()</b> ( )	1,965.	2,000.	2,069.	2,150.	2,220.	2,315.	2,380.
	48"	79"	<b>R3B1TFL79 48-()</b> ( )	2,027.	2,062.	2,131.	2,212.	2,282.	2,377.	2,441.

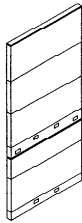

Order Code	Specification Information	Application Notes
Example: <b>R3B0TFL7918-A4K</b>	<i>To order please specify pattern number including:</i>	
<b>R3</b> Reff Generation 3	1. Top trim profile	8. Base finish
<b>B0</b> No Beltway	2. Base height	9. Beltway finish, for panels with Beltway
<b>T</b> Tiled panel	3. Knockout option (K = with knockouts, N = without knockouts)	10. <i>Optional non-beltway panels:</i> specify (M) for panel frame to be milled for ported components, \$14 list upcharge applicable
<b>FL</b> Fabric one side, laminate other	4. Tile divider B = black steel divider or specify AA-anodized aluminum or painted option excluding silver from page 5 for extruded aluminum divider (upcharge applicable for extruded aluminum divider)	1. <i>Top trim profile:</i> A = Flat B = Square C = Bullnose E = Extruded Aluminum
<b>79</b> 79" high	5. Fabric side, finish (specify selection per insert) i) tile 1A bottom ii) tile 1B middle iii) tile 1C middle iv) tile 1D middle v) tile 1E top	2. <i>Base height:</i> 4 = 4" base height 6 = 6" base height (add \$47 per panel for this option)
<b>18</b> 18" wide	6. Laminate side, finish (specify selection per insert) i) tile 2A bottom ii) tile 2B middle iii) tile 2C middle iv) tile 2D middle v) tile 2E top	4. <i>Extruded aluminum tile divider: Optional for non fabric side only</i> (fabric side always black) 79" h add per panel: \$48 for 18w and 20w \$57 for 24w and 30w \$62 for 36w and 42w \$84 for 48w
<b>A</b> Flat style top trim profile	7. Top trim finish i) Profile A, B or C options: V1, V2, V3, P1, P2, P3 finishes ii) Profile E options: AA-anodized aluminum or painted finish from page 5 excluding silver	Product on this page will not accept stacking modules.  6" Raceway option increases panel height by 2 3/4".  Product on this page can be attached to posts 79"H as well as panels 42", 49", 64" and 79"H. Panels on this page will not attach to panels made before April 1997 without an attachment kit from page 117.  Remember to specify Beltway paint finish when applicable.  79"H hookstrip reveal strips are ordered separately from page 117 at no charge.
<b>4</b> 4" base height		Applicable finishes are listed on page 5 and 6.
<b>K</b> Include knockouts in base		Product on this page excluding Beltway panels will accept wood grain laminate where laminate is currently an option. Panel product is subject to a 10% upcharge on the base panel price. Refer to panel product upcharge table.
<b>B</b> Tile divider, black reveal		
<b>W281</b> Fabric - Side 1A		
<b>W281</b> Fabric - Side 1B		
<b>W281</b> Fabric - Side 1C		
<b>W281</b> Fabric - Side 1D		
<b>W281</b> Fabric - Side 1E		
<b>114</b> Folkstone grey - side 2A		
<b>114</b> Folkstone grey - side 2B		
<b>114</b> Folkstone grey - side 2C		
<b>114</b> Folkstone grey - side 2D		
<b>114</b> Folkstone grey - side 2E		
<b>V316</b> Maple (top trim finish)		
<b>111</b> Jet Black (base finish)		
<b>M</b> Optional milled frame		



# Tiled panels 79" H

*fabric one side, techwood other side*

description	w	h	pattern no.	grade						
				10	15	20	30	35	40	45
Tiled, fabric one side	18"	79"	<b>R3B0TF179 18-()</b> ( )	\$1,225.	\$1,260.	\$1,340.	\$1,420.	\$1,490.	\$1,595.	\$1,660.
Regular acoustics	20"	79"	<b>R3B0TF179 20-()</b> ( )	1,225.	1,260.	1,340.	1,420.	1,490.	1,595.	1,660.
	24"	79"	<b>R3B0TF179 24-()</b> ( )	1,295.	1,330.	1,410.	1,490.	1,560.	1,665.	1,730.
	30"	79"	<b>R3B0TF179 30-()</b> ( )	1,361.	1,396.	1,474.	1,556.	1,626.	1,731.	1,796.
	36"	79"	<b>R3B0TF179 36-()</b> ( )	1,428.	1,463.	1,543.	1,623.	1,693.	1,798.	1,863.
	42"	79"	<b>R3B0TF179 42-()</b> ( )	1,602.	1,637.	1,717.	1,797.	1,867.	1,972.	2,037.
	48"	79"	<b>R3B0TF179 48-()</b> ( )	1,676.	1,711.	1,791.	1,871.	1,941.	2,046.	2,111.

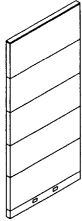

Tiled, fabric one side	18"	79"	<b>R3B1TF179 18-()</b> ( )	1,548.	1,583.	1,663.	1,743.	1,813.	1,918.	1,983.
Beltway one side (fabric side)	20"	79"	<b>R3B1TF179 20-()</b> ( )	1,548.	1,583.	1,663.	1,743.	1,813.	1,918.	1,983.
	24"	79"	<b>R3B1TF179 24-()</b> ( )	1,618.	1,653.	1,733.	1,813.	1,883.	1,988.	2,053.
	30"	79"	<b>R3B1TF179 30-()</b> ( )	1,648.	1,683.	1,763.	1,843.	1,913.	2,018.	2,083.
	36"	79"	<b>R3B1TF179 36-()</b> ( )	1,983.	2,018.	2,098.	2,178.	2,248.	2,353.	2,418.
	42"	79"	<b>R3B1TF179 42-()</b> ( )	2,112.	2,147.	2,227.	2,307.	2,377.	2,482.	2,547.
	48"	79"	<b>R3B1TF179 48-()</b> ( )	2,178.	2,213.	2,293.	2,373.	2,443.	2,548.	2,613.

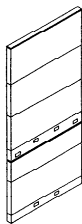

Order Code	Specification Information	Application Notes
Example: <b>R3B0TF17918-A4K</b>	<i>To order please specify pattern number including:</i>	
<b>R3</b> Reff Generation 3	1. Top trim profile	8. Base finish
<b>B0</b> No Beltway	2. Base height	9. Beltway finish, for panels with beltway
<b>T</b> Tiled panel	3. Knockout option (K = with knockouts, N = without knockouts)	10. <i>Optional non-beltway panels:</i> specify (M) for panel frame to be milled for ported components, \$14 list upcharge applicable
<b>F1</b> Fabric one side, V1 other	4. Tile divider B = black steel divider or specify AA-anodized aluminum or painted option excluding silver from page 5 for extruded aluminum divider (upcharge applicable for extruded aluminum divider)	6" Raceway option increases panel height by 2 3/4".
<b>79</b> 79" high	5. Fabric side, finish (specify selection per insert) i) tile 1A bottom ii) tile 1B middle iii) tile 1C middle iv) tile 1D middle v) tile 1E top	Product on this page can be attached to posts 79"H as well as panels 42", 49", 64" and 79"H. Panels on this page will not attach to panels made before April 1997 without an attachment kit from page 117.
<b>18</b> 18" wide	6. Techwood side, finish (specify one V1 finish for side)	Remember to specify Beltway paint finish when applicable.
<b>A</b> Flat style top trim profile	7. Top trim finish i) Profile A, B or C options: V1, V2, V3, P1, P2, P3 finishes ii) Profile E options: AA-anodized aluminum or painted finish from page 5 excluding silver	79"H hookstrip reveal strips are ordered separately from page 117 at no charge.
<b>4</b> 4" base height		
<b>K</b> Include knockouts in base		
<b>B</b> Tile divider, black reveal		
<b>W281</b> Fabric - Side 1A		
<b>W281</b> Fabric - Side 1B		
<b>W281</b> Fabric - Side 1C		
<b>W281</b> Fabric - Side 1D		
<b>W281</b> Fabric - Side 1E		
<b>Y328</b> Mahogany - side 2A		
<b>Y328</b> Mahogany - side 2B		
<b>Y328</b> Mahogany - side 2C		
<b>Y328</b> Mahogany - side 2D		
<b>Y328</b> Mahogany - side 2E		
<b>V316</b> Maple (top trim finish)		
<b>111</b> Jet Black (base finish)		
<b>M</b> Optimal milled frame		

# Tiled panels 79" H

*fabric one side, conventional veneer other side*

description	w	h	pattern no.	grade						
				10	15	20	30	35	40	45
Tiled, fabric one side	18"	79"	<b>R3B0TF279 18-()</b> ( )	\$1,246.	\$1,281.	\$1,361.	\$1,441.	\$1,511.	\$1,616.	\$1,681.
Regular acoustics	20"	79"	<b>R3B0TF279 20-()</b> ( )	1,246.	1,281.	1,361.	1,441.	1,511.	1,616.	1,681.
	24"	79"	<b>R3B0TF279 24-()</b> ( )	1,318.	1,353.	1,433.	1,513.	1,583.	1,688.	1,753.
	30"	79"	<b>R3B0TF279 30-()</b> ( )	1,383.	1,418.	1,498.	1,578.	1,648.	1,753.	1,818.
	36"	79"	<b>R3B0TF279 36-()</b> ( )	1,453.	1,488.	1,568.	1,648.	1,718.	1,823.	1,888.
	42"	79"	<b>R3B0TF279 42-()</b> ( )	1,628.	1,663.	1,743.	1,823.	1,893.	1,998.	2,063.
	48"	79"	<b>R3B0TF279 48-()</b> ( )	1,704.	1,739.	1,819.	1,899.	1,969.	2,074.	2,139.

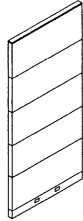

Tiled, fabric one side	18"	79"	<b>R3B1TF279 18-()</b> ( )	1,575.	1,610.	1,690.	1,770.	1,840.	1,945.	2,010.
Beltway one side (fabric side)	20"	79"	<b>R3B1TF279 20-()</b> ( )	1,575.	1,610.	1,690.	1,770.	1,840.	1,945.	2,010.
	24"	79"	<b>R3B1TF279 24-()</b> ( )	1,646.	1,681.	1,761.	1,841.	1,911.	2,016.	2,081.
	30"	79"	<b>R3B1TF279 30-()</b> ( )	1,681.	1,716.	1,796.	1,876.	1,946.	2,051.	2,116.
	36"	79"	<b>R3B1TF279 36-()</b> ( )	2,020.	2,055.	2,135.	2,215.	2,285.	2,390.	2,455.
	42"	79"	<b>R3B1TF279 42-()</b> ( )	2,147.	2,182.	2,262.	2,342.	2,412.	2,517.	2,582.
	48"	79"	<b>R3B1TF279 48-()</b> ( )	2,217.	2,252.	2,332.	2,412.	2,482.	2,587.	2,652.



Order Code	Specification Information	Application Notes
Example: <b>R3B0TF17918-A4K</b>	<i>To order please specify pattern number including:</i>	The panels on this page will not accept stacking modules.
<b>R3</b> Reff Generation 3	1. Top trim profile	6" Raceway option increases panel height by 2 3/4".
<b>B0</b> No Beltway	2. Base height	
<b>T</b> Tiled panel	3. Knockout option (K = with knockouts, N = without knockouts)	Product on this page can be attached to posts 79"H as well as panels 42", 49", 64" and 79"H. Panels on this page will not attach to panels made before April 1997 without an attachment kit from page 117.
<b>F1</b> Fabric one side, V1 other	4. Tile divider B = black steel divider or specify AA-anodized aluminum or painted option excluding silver from page 5 for extruded aluminum divider (upcharge applicable for extruded aluminum divider)	
<b>79</b> 79" high	5. Fabric side, finish (specify selection per insert) i) tile 1A bottom ii) tile 1B middle iii) tile 1C middle iv) tile 1D middle v) tile 1E top	Remember to specify Beltway paint finish when applicable. 79"H hookstrip reveal strips are ordered separately from page 117 at no charge.
<b>18</b> 18" wide	6. Techwood side, finish (specify one V1 finish for side)	
<b>A</b> Flat style top trim profile	7. Top trim finish i) Profile A, B or C options: V1, V2, V3, P1, P2, P3 finishes ii) Profile E options: AA-anodized aluminum or painted finish from page 5 excluding silver	Applicable finishes are listed on page 5 and 6.
<b>4</b> 4" base height	8. Base finish	
<b>K</b> Include knockouts in base	9. Beltway finish, for panels with Beltway	
<b>B</b> Tile divider, black reveal	10. <i>Optional non-beltway panels:</i> specify (M) for panel frame to be milled for ported components, \$14 list upcharge applicable	
<b>W281</b> Fabric - Side 1A	1. <i>Top trim profile:</i> A = Flat B = Square C = Bullnose E = Extruded Aluminum	
<b>W281</b> Fabric - Side 1B	2. <i>Base height:</i> 4 = 4" base height 6 = 6" base height (add \$47 per panel for this option)	
<b>W281</b> Fabric - Side 1C	4. <i>Extruded aluminum tile divider: Optional for non fabric side only</i> (fabric side always black) 79"h add per panel: \$52 for 18w and 20w \$60 for 24w and 30w \$64 for 36w and 42w \$86 for 48w	
<b>W281</b> Fabric - Side 1D		
<b>W281</b> Fabric - Side 1E		
<b>Y328</b> Mahogany - side 2 Tiled		
<b>V316</b> Maple (top trim finish)		
<b>111</b> Jet Black (base finish)		
<b>M</b> Optional milled frame		

# Tiled panels 79" H

*fabric one side, exotic veneer other side*

description	w	h	pattern no.	grade						
				10	15	20	30	35	40	45
Tiled, fabric one side	18"	79"	<b>R3B0TF379 18-()()</b>	\$1,653.	\$1,688.	\$1,768.	\$1,848.	\$1,918.	\$2,023.	\$2,088.
Regular acoustics	20"	79"	<b>R3B0TF379 20-()()</b>	1,653.	1,688.	1,768.	1,848.	1,918.	2,023.	2,088.
	24"	79"	<b>R3B0TF379 24-()()</b>	1,751.	1,786.	1,866.	1,946.	2,016.	2,121.	2,186.
	30"	79"	<b>R3B0TF379 30-()()</b>	1,841.	1,876.	1,956.	2,036.	2,106.	2,211.	2,276.
	36"	79"	<b>R3B0TF379 36-()()</b>	1,935.	1,970.	2,050.	2,130.	2,200.	2,305.	2,370.
	42"	79"	<b>R3B0TF379 42-()()</b>	2,171.	2,206.	2,286.	2,366.	2,436.	2,541.	2,606.
	48"	79"	<b>R3B0TF379 48-()()</b>	2,273.	2,308.	2,388.	2,468.	2,538.	2,643.	2,708.

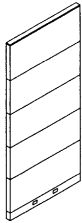

Tiled, fabric one side	18"	79"	<b>R3B1TF379 18-()()</b>	2,100.	2,135.	2,215.	2,295.	2,365.	2,470.	2,535.
Beltway fabric side	20"	79"	<b>R3B1TF379 20-()()</b>	2,100.	2,135.	2,215.	2,295.	2,365.	2,470.	2,535.
	24"	79"	<b>R3B1TF379 24-()()</b>	2,195.	2,230.	2,310.	2,390.	2,460.	2,565.	2,630.
	30"	79"	<b>R3B1TF379 30-()()</b>	2,242.	2,277.	2,357.	2,437.	2,507.	2,612.	2,677.
	36"	79"	<b>R3B1TF379 36-()()</b>	2,699.	2,734.	2,814.	2,894.	2,964.	3,069.	3,134.
	42"	79"	<b>R3B1TF379 42-()()</b>	2,873.	2,908.	2,988.	3,068.	3,138.	3,243.	3,308.
	48"	79"	<b>R3B1TF379 48-()()</b>	2,967.	3,002.	3,082.	3,162.	3,232.	3,337.	3,402.

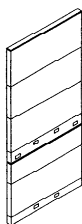

Order Code	Specification Information	Application Notes
Example: <b>R3B0TF37918-A4K</b>	<i>To order please specify pattern number including:</i>	<i>1. Top trim profile:</i>
<b>R3</b> Reff Generation 3	1. Top trim profile	A = Flat
<b>B0</b> No Beltway	2. Base height	B = Square
<b>T</b> Tiled panel	3. Knockout option	C = Bullnose
<b>F3</b> Fabric one side, V3 other	(K = with knockouts, N = without knockouts)	E = Extruded Aluminum
<b>79</b> 79" high	4. Tile divider	<i>2. Base height:</i>
<b>18</b> 18" wide	B = black steel divider or specify AA-anodized aluminum or painted option excluding silver from page 5 for extruded aluminum divider (upcharge applicable for extruded aluminum divider)	4 = 4" base height
<b>A</b> Flat style top trim profile	5. Fabric side, finish (specify selection per insert)	6 = 6" base height (add \$47 per panel for this option)
<b>4</b> 4" base height	i) tile 1A bottom	<i>4. Extruded aluminum tile divider: Optional for non fabric side only</i> (fabric side always black)
<b>K</b> Include knockouts in base	ii) tile 1B middle	79" h add per panel:
<b>B</b> Tile divider, black reveal	iii) tile 1C middle	\$52 for 18w and 20w
<b>W281</b> Fabric - Side 1A	iv) tile 1D middle	\$60 for 24w and 30w
<b>W281</b> Fabric - Side 1B	v) tile 1E top	\$64 for 36w and 42w
<b>W281</b> Fabric - Side 1C	6. Exotic veneer, finish (specify one V3 finish for side)	\$86 for 48w
<b>W281</b> Fabric - Side 1D	7. Top trim finish	Applicable finishes are listed on page 5 and 6.
<b>W281</b> Fabric - Side 1E	i) Profile A, B or C options: V1, V2, V3, P1, P2, P3 finishes	
<b>V512</b> Figured Anigre surface - side 2 tiled	ii) Profile E options: AA-anodized aluminum or painted finish from page 5 excluding silver	
<b>V512</b> Figured Anigre (top trim finish)	8. Base finish	
<b>111</b> Jet Black (base finish)	9. Beltway finish, for panels with Beltway	
<b>M</b> Optional milled frame	10. <i>Optional non-beltway panels:</i> specify (M) for panel frame to be milled for ported components, \$14 list upcharge applicable	

The panels on this page will not accept stacking modules.

6" Raceway option increases panel height by 2<sup>3</sup>/<sub>4</sub>".

Product on this page can be attached to posts 79"H as well as panels 42", 49", 64" and 79"H . Panels on this page will not attach to panels made before April 1997 without an attachment kit from page 117.

Remember to specify Beltway paint finish when applicable.

79"H hookstrip reveal strips are ordered separately from page 117 at no charge.

# Tiled panels 79" H

## Laminate/Laminate

description	w	h	pattern no.	L
Tiled, laminate both sides	18"	79"	<b>R3B0TLL7918</b> ( ) ( )	\$1,298.
with raceway both sides	20"	79"	<b>R3B0TLL7920</b> ( ) ( )	1,298.
	24"	79"	<b>R3B0TLL7924</b> ( ) ( )	1,415.
	30"	79"	<b>R3B0TLL7930</b> ( ) ( )	1,585.
	36"	79"	<b>R3B0TLL7936</b> ( ) ( )	1,712.
	42"	79"	<b>R3B0TLL7942</b> ( ) ( )	1,763.
	48"	79"	<b>R3B0TLL7948</b> ( ) ( )	1,852.

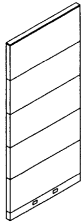

Example:	<b>R3B0TLL7918-A4K</b>
<b>R3</b>	Reff Generation 3
<b>B0</b>	No Beltway
<b>T</b>	Tiled panel
<b>LL</b>	Laminate both sides
<b>79</b>	79" high
<b>18</b>	18" wide
<b>A</b>	Flat style top trim profile
<b>4</b>	4" base height
<b>K</b>	Include knockouts in base
<b>B</b>	Tile divider, black reveal
<b>118</b>	Laminate - side 1A
<b>118</b>	Laminate - side 1B
<b>118</b>	Laminate - side 1C
<b>118</b>	Laminate - side 1D
<b>118</b>	Laminate - side 1E
<b>118</b>	Laminate - side 2A
<b>118</b>	Laminate - side 2B
<b>118</b>	Laminate - side 2C
<b>118</b>	Laminate - side 2D
<b>118</b>	Laminate - side 2E
<b>V512</b>	Figured Anigre (top trim finish)
<b>111</b>	Jet Black (base finish)
<b>M</b>	Optional milled frame

To order please specify pattern number including:

1. Top trim profile
2. Base height
3. Knockout option  
(K = with knockouts, N = without knockouts)
4. Tile divider  
B = black steel divider or specify AA-anodized aluminum or painted option excluding silver from page 5 for extruded aluminum divider (upcharge applicable for extruded aluminum divider)
5. Laminate side, finish (specify selection per insert)  
i) tile 1A bottom  
ii) tile 1B middle  
iii) tile 1C middle  
iv) tile 1D middle  
v) tile 1E top
6. Laminate, finish
7. Top trim finish  
i) Profile A, B or C options:  
V1, V2, V3, P1, P2, P3 finishes  
ii) Profile E options:  
AA-anodized aluminum or painted finish from page 5 excluding silver
8. Base finish
9. *Optional non-beltway panels:* specify (M) for panel frame to be milled for ported components, \$14 list upcharge applicable

1. Top trim profile:

- A = Flat
- B = Square
- C = Bullnose
- E = Extruded Aluminum

2. Base height:

- 4 = 4" base height

4. Extruded aluminum tile divider:

- Optional for non fabric side only**  
(fabric side always black)  
79"h add per panel:  
\$52 for 18w and 20w  
\$60 for 24w and 30w  
\$64 for 36w and 42w  
\$86 for 48w

Applicable finishes are listed on page 5 and 6.

Product on this page will accept wood grain laminate where laminate is currently an option. Panel product is subject to a 10% upcharge on the base panel price. Refer to panel product upcharge table.

The panels on this page will not accept stacking modules.

Product on this page can be attached to posts 79"H as well as panels 42", 49", 64" and 79"H. Panels on this page will not attach to panels made before April 1997 without an attachment kit from page 117.

Remember to specify Beltway paint finish when applicable.

79"H hookstrip reveal strips are ordered separately from page 117 at no charge.

description	width	height	pattern no.	AA or paint finish	list
Aluminum reveal kit for 34" h tiled with 4" or 6" h base raceway	18"	34"	<b>R2APT3418 ( )</b>	\$99.	
	20"	34"	<b>R2APT3420 ( )</b>	99.	
	24"	34"	<b>R2APT3424 ( )</b>	102.	
	30"	34"	<b>R2APT3430 ( )</b>	104.	
	36"	34"	<b>R2APT3436 ( )</b>	109.	
	42"	34"	<b>R2APT3442 ( )</b>	111.	
	48"	34"	<b>R2APT3448 ( )</b>	116.	

Retrofit kit for Reff panels purchased under pattern numbers prefixed "R2".  
Kit includes vertical hookstrip cover and tile dividers

Aluminum reveal kit for 42" h tiled with 4" or 6" h base raceway	18"	42"	<b>R2APT4218 ( )</b>	152.	
	20"	42"	<b>R2APT4220 ( )</b>	152.	
	24"	42"	<b>R2APT4224 ( )</b>	157.	
	30"	42"	<b>R2APT4230 ( )</b>	159.	
	36"	42"	<b>R2APT4236 ( )</b>	168.	
	42"	42"	<b>R2APT4242 ( )</b>	173.	
	48"	42"	<b>R2APT4248 ( )</b>	181.	

Retrofit kit for Reff panels purchased under pattern numbers prefixed "R2".  
Kit includes vertical hookstrip cover and tile dividers

Order Code	Specification Information	Application Notes										
Example: <b>R2APT3418 AA</b> <b>R2</b> Reff Generation 2 <b>A</b> Aluminum <b>PT</b> Panel trim <b>34</b> for 34" h <b>18</b> for 18" w <b>AA</b> Anodized aluminum	<p><i>To order specify pattern number including height and width as applicable.</i></p> <p>1. Specify reveal finish AA-anodized aluminum or painted option from page 5 excluding silver</p> <p>Aluminum reveal kits for one side of tiled panel only, and include one vertical and one or more horizontal pieces. Chart below shows number of vertical to horizontal pieces for each kit by height.</p> <table> <tr><td>34" h</td><td>1:1</td></tr> <tr><td>42" h</td><td>1:2</td></tr> <tr><td>49" h</td><td>1:2</td></tr> <tr><td>64" h</td><td>1:3</td></tr> <tr><td>79" h</td><td>1:4</td></tr> </table> <p>Aluminum reveal kits and hookstrip covers best suited for hard side (laminated, V1, V2 or V3) of panels only. Not recommended for fabric tiled side of panels. Recommend use on outside of stations/clusters only. Where and</p>	34" h	1:1	42" h	1:2	49" h	1:2	64" h	1:3	79" h	1:4	<p>when aluminum vertical hookstrip cover installed, forfeit panel hung capability.</p> <p>When conditions include stacking modules (glass or other), specify vertical and horizontal pieces individually. R2APT kits are for tiled panels without stacking modules. Specify R2AHCR or R2AHCN for overall stacked height, then horizontal pieces for specific condition (between base panel inserts, between base panel and window, etc.)</p> <p>Products on this page are field installed, installation instructions and relocation clip instructions ships with kit.</p> <p>R2APT, R2AHTR and R2AHSR for use only on Reff generation 2 panels.</p> <p>R2APT products for Reff generation 2 panels for panel side with exposed 4" h or 6" h base raceway.</p> <p>Aluminum reveal kits are retrofittable to all generation 2 panels. Note for installation on generation 2 panels manufactured before January 1, 2004 it will be necessary to relocate attachment clips on the back of inserts to capture the horizontal reveal.</p>
34" h	1:1											
42" h	1:2											
49" h	1:2											
64" h	1:3											
79" h	1:4											

description	width	height	pattern no.	AA or paint finish	list
Aluminum reveal kit for 49" h tiled with 4" or 6" h base raceway	18"	49"	<b>R2APT4918 ( )</b>	\$163.	
	20"	49"	<b>R2APT4920 ( )</b>	163.	
	24"	49"	<b>R2APT4924 ( )</b>	169.	
	30"	49"	<b>R2APT4930 ( )</b>	171.	
	36"	49"	<b>R2APT4936 ( )</b>	180.	
	42"	49"	<b>R2APT4942 ( )</b>	187.	
	48"	49"	<b>R2APT4948 ( )</b>	193.	

Retrofit kit for Reff panels purchased under pattern numbers prefixed "R2".  
Kit includes vertical hookstrip cover and tile dividers

Aluminum reveal kit for 64" h tiled with 4" or 6" h base raceway	18"	64"	<b>R2APT6418 ( )</b>	230.	
	20"	64"	<b>R2APT6420 ( )</b>	230.	
	24"	64"	<b>R2APT6424 ( )</b>	239.	
	30"	64"	<b>R2APT6430 ( )</b>	244.	
	36"	64"	<b>R2APT6436 ( )</b>	255.	
	42"	64"	<b>R2APT6442 ( )</b>	265.	
	48"	64"	<b>R2APT6448 ( )</b>	275.	

Retrofit kit for Reff panels purchased under pattern numbers prefixed "R2".  
Kit includes vertical hookstrip cover and tile dividers

Order Code	Specification Information	Application Notes										
Example: <b>R2APT3418 AA</b>	<i>To order specify pattern number including height and width as applicable.</i>	when aluminum vertical hookstrip cover installed, forfeit panel hung capability.										
<b>R2</b> Reff Generation 2		R2APT, R2AHTR and R2AHSR for use only on Reff generation 2 panels.										
<b>A</b> Aluminum												
<b>PT</b> Panel trim	1. Specify reveal finish	When conditions include stacking modules (glass or other), specify vertical and horizontal pieces individually. R2APT kits are for tiled panels without stacking modules. Specify R2AHCR or R2AHCN for overall stacked height, then horizontal pieces for specific condition (between base panel inserts, between base panel and window, etc.)										
<b>34</b> for 34" h	AA-anodized aluminum or painted option from page 5 excluding silver	Products on this page are field installed, installation instructions and relocation clip instructions ships with kit.										
<b>18</b> for 18" w	Aluminum reveal kits for one side of tiled panel only, and include one vertical and one or more horizontal pieces. Chart below shows number of vertical to horizontal pieces for each kit by height.	R2APT products for Reff generation 2 panels for panel side with exposed 4" h or 6" h base raceway.										
<b>AA</b> Anodized aluminum	<table border="0"> <tr><td>34" h</td><td>1:1</td></tr> <tr><td>42" h</td><td>1:2</td></tr> <tr><td>49" h</td><td>1:2</td></tr> <tr><td>64" h</td><td>1:3</td></tr> <tr><td>79" h</td><td>1:4</td></tr> </table>	34" h	1:1	42" h	1:2	49" h	1:2	64" h	1:3	79" h	1:4	Aluminum reveal kits are retrofittable to all generation 2 panels. Note for installation on generation 2 panels manufactured before January 1, 2004 it will be necessary to relocate attachment clips on the back of inserts to capture the horizontal reveal.
34" h	1:1											
42" h	1:2											
49" h	1:2											
64" h	1:3											
79" h	1:4											
	Aluminum reveal kits and hookstrip covers best suited for hard side (laminated, V1, V2 or V3) of panels only. Not recommended for fabric tiled side of panels. Recommend use on outside of stations/clusters only. Where and											

description	width	height	pattern no.	AA or paint finish	list
Aluminum reveal kit for 79" h tiled with 4" or 6" h base raceway	18"	79"	<b>R2APT7918</b> ( )	\$298.	
	20"	79"	<b>R2APT7920</b> ( )	298.	
	24"	79"	<b>R2APT7924</b> ( )	308.	
	30"	79"	<b>R2APT7930</b> ( )	314.	
	36"	79"	<b>R2APT7936</b> ( )	331.	
	42"	79"	<b>R2APT7942</b> ( )	342.	
	48"	79"	<b>R2APT7948</b> ( )	359.	

Retrofit kit for Reff panels purchased under pattern numbers prefixed "R2".  
Kit includes vertical hookstrip cover and tile dividers

Aluminum reveal kit for T post with 4" or 6" h raceway	34"	<b>R2ATPK34</b> ( )	66.
	42"	<b>R2ATPK42</b> ( )	83.
	49"	<b>R2ATPK49</b> ( )	94.
	64"	<b>R2ATPK64</b> ( )	130.
	79"	<b>R2ATPK79</b> ( )	163.

Order Code	Specification Information	Application Notes																						
<p>Example: <b>R2APT3418 AA</b></p> <table border="1"> <tr> <td><b>R2</b></td> <td>Reff Generation 2</td> </tr> <tr> <td><b>A</b></td> <td>Aluminum</td> </tr> <tr> <td><b>PT</b></td> <td>Panel trim</td> </tr> <tr> <td><b>34</b></td> <td>for 34" h</td> </tr> <tr> <td><b>18</b></td> <td>for 18" w</td> </tr> <tr> <td><b>AA</b></td> <td>Anodized aluminum</td> </tr> </table>	<b>R2</b>	Reff Generation 2	<b>A</b>	Aluminum	<b>PT</b>	Panel trim	<b>34</b>	for 34" h	<b>18</b>	for 18" w	<b>AA</b>	Anodized aluminum	<p><i>To order specify pattern number including height and width as applicable.</i></p> <p>1. Specify reveal finish AA-anodized aluminum or painted option from page 5 excluding silver</p> <p>Aluminum reveal kits for one side of tiled panel only, and include one vertical and one or more horizontal pieces. Chart below shows number of vertical to horizontal pieces for each kit by height.</p> <table border="1"> <tr> <td>34" h</td> <td>1:1</td> </tr> <tr> <td>42" h</td> <td>1:2</td> </tr> <tr> <td>49" h</td> <td>1:2</td> </tr> <tr> <td>64" h</td> <td>1:3</td> </tr> <tr> <td>79" h</td> <td>1:4</td> </tr> </table> <p>Aluminum reveal kits and hookstrip covers best suited for hard side (laminated, V1, V2 or V3) of panels only. Not recommended for fabric tiled side of panels. Recommend use on outside of stations/clusters only. Where and</p>	34" h	1:1	42" h	1:2	49" h	1:2	64" h	1:3	79" h	1:4	<p>when aluminum vertical hookstrip cover installed, forfeit panel hung capability.</p> <p>When conditions include stacking modules (glass or other), specify vertical and horizontal pieces individually. R2APT kits are for tiled panels without stacking modules. Specify R2AHCR or R2AHCN for overall stacked height, then horizontal pieces for specific condition (between base panel inserts, between base panel and window, etc.)</p> <p>Products on this page are field installed, installation instructions and relocation clip instructions ships with kit.</p> <p>R2APT, R2AHTR and R2AHSR for use only on Reff generation 2 panels.</p> <p>R2APT products for Reff generation 2 panels for panel side with exposed 4" h or 6" h base raceway.</p> <p>Aluminum reveal kits are retrofittable to all generation 2 panels. Note for installation on generation 2 panels manufactured before January 1, 2004 it will be necessary to relocate attachment clips on the back of inserts to capture the horizontal reveal.</p>
<b>R2</b>	Reff Generation 2																							
<b>A</b>	Aluminum																							
<b>PT</b>	Panel trim																							
<b>34</b>	for 34" h																							
<b>18</b>	for 18" w																							
<b>AA</b>	Anodized aluminum																							
34" h	1:1																							
42" h	1:2																							
49" h	1:2																							
64" h	1:3																							
79" h	1:4																							

description	width	height	pattern no.	AA or paint finish	list
Aluminum reveal kit for L post with 4" or 6"h raceway		34"	<b>R2ALPK34 ( )</b>		\$65.
		42"	<b>R2ALPK42 ( )</b>		90.
		49"	<b>R2ALPK49 ( )</b>		99.
		64"	<b>R2ALPK64 ( )</b>		137.
		79"	<b>R2ALPK79 ( )</b>		173.
Alum vertical reveal for end trim with 4" or 6"h raceway		34"	<b>R2AETK34 ( )</b>		64.
		42"	<b>R2AETK42 ( )</b>		78.
		49"	<b>R2AETK49 ( )</b>		91.
		64"	<b>R2AETK64 ( )</b>		121.
		79"	<b>R2AETK79 ( )</b>		153.

for use with generation 2 or 3 installations

Order Code	Specification Information	Application Notes										
Example: <b>R2APT3418 AA</b>	<i>To order specify pattern number including height and width as applicable.</i>	when aluminum vertical hookstrip cover installed, forfeit panel hung capability.										
<b>R2</b> Reff Generation 2	1. Specify reveal finish AA-anodized aluminum or painted option from page 5 excluding silver	When conditions include stacking modules (glass or other), specify vertical and horizontal pieces individually. R2APT kits are for tiled panels without stacking modules. Specify R2AHCR or R2AHCN for overall stacked height, then horizontal pieces for specific condition (between base panel inserts, between base panel and window, etc.)										
<b>A</b> Aluminum	Aluminum reveal kits for one side of tiled panel only, and include one vertical and one or more horizontal pieces. Chart below shows number of vertical to horizontal pieces for each kit by height.	R2APT, R2AHTR and R2AHSR for use only on Reff generation 2 panels.										
<b>PT</b> Panel trim		R2APT products for Reff generation 2 panels for panel side with exposed 4"h or 6"h base raceway.										
<b>34</b> for 34"h		Aluminum reveal kits are retrofittable to all generation 2 panels. Note for installation on generation 2 panels manufactured before January 1, 2004 it will be necessary to relocate attachment clips on the back of inserts to capture the horizontal reveal.										
<b>18</b> for 18"w												
<b>AA</b> Anodized aluminum		Products on this page are field installed, installation instructions and relocation clip instructions ships with kit.										
	<table border="0"> <tr> <td>34"h</td> <td>1:1</td> </tr> <tr> <td>42"h</td> <td>1:2</td> </tr> <tr> <td>49"h</td> <td>1:2</td> </tr> <tr> <td>64"h</td> <td>1:3</td> </tr> <tr> <td>79"h</td> <td>1:4</td> </tr> </table>	34"h	1:1	42"h	1:2	49"h	1:2	64"h	1:3	79"h	1:4	
34"h	1:1											
42"h	1:2											
49"h	1:2											
64"h	1:3											
79"h	1:4											
	Aluminum reveal kits and hookstrip covers best suited for hard side (lamine, V1, V2 or V3) of panels only. Not recommended for fabric tiled side of panels. Recommend use on outside of stations/clusters only. Where and											



description	width	height	pattern no.	AA or paint finish	list
Aluminum hookstrip cover condition including stacking modules with 4" or 6"h base raceway		30"	<b>R2AHCR34 ( )</b>		\$64.
		38"	<b>R2AHCR42 ( )</b>		78.
		45"	<b>R2AHCR49 ( )</b>		91.
		60"	<b>R2AHCR64 ( )</b>		121.
		75"	<b>R2AHCR79 ( )</b>		153.

for use with generation 2 or 3 installations

Alum horizontal reveal/tile divider for between laminate or wood inserts	18"		<b>R2AHTR18 ( )</b>		44.
	20"		<b>R2AHTR20 ( )</b>		44.
	24"		<b>R2AHTR24 ( )</b>		46.
	30"		<b>R2AHTR30 ( )</b>		50.
	36"		<b>R2AHTR36 ( )</b>		54.
	42"		<b>R2AHTR42 ( )</b>		56.
	48"		<b>R2AHTR48 ( )</b>		63.

horizontal reveal only

Order Code	Specification Information	Application Notes										
Example: <b>R2APT3418 AA</b>	<i>To order specify pattern number including height and width as applicable.</i>	when aluminum vertical hookstrip cover installed, forfeit panel hung capability.										
<b>R2</b> Reff Generation 2	1. Specify reveal finish AA-anodized aluminum or painted option from page 5 excluding silver	When conditions include stacking modules (glass or other), specify vertical and horizontal pieces individually. R2APT kits are for tiled panels without stacking modules. Specify R2AHCR or R2AHCN for overall stacked height, then horizontal pieces for specific condition (between base panel inserts, between base panel and window, etc.)										
<b>A</b> Aluminum	Aluminum reveal kits for one side of tiled panel only, and include one vertical and one or more horizontal pieces. Chart below shows number of vertical to horizontal pieces for each kit by height.	R2APT, R2AHTR and R2AHSR for use only on Reff generation 2 panels.										
<b>PT</b> Panel trim		R2APT products for Reff generation 2 panels for panel side with exposed 4"h or 6"h base raceway.										
<b>34</b> for 34"h		Aluminum reveal kits are retrofittable to all generation 2 panels. Note for installation on generation 2 panels manufactured before January 1, 2004 it will be necessary to relocate attachment clips on the back of inserts to capture the horizontal reveal.										
<b>18</b> for 18"w												
<b>AA</b> Anodized aluminum		Products on this page are field installed, installation instructions and relocation clip instructions ships with kit.										
	<table border="0"> <tr><td>34"h</td><td>1:1</td></tr> <tr><td>42"h</td><td>1:2</td></tr> <tr><td>49"h</td><td>1:2</td></tr> <tr><td>64"h</td><td>1:3</td></tr> <tr><td>79"h</td><td>1:4</td></tr> </table>	34"h	1:1	42"h	1:2	49"h	1:2	64"h	1:3	79"h	1:4	
34"h	1:1											
42"h	1:2											
49"h	1:2											
64"h	1:3											
79"h	1:4											
	Aluminum reveal kits and hookstrip covers best suited for hard side (laminate, V1, V2 or V3) of panels only. Not recommended for fabric tiled side of panels. Recommend use on outside of stations/clusters only. Where and											

description	width	height	pattern no.	AA or paint finish	list
Alum horizontal reveal for between base panel and stacking window module or stacking and window modules or between two stacking modules	18"		<b>R2AHWR18 ( )</b>	\$38.	
	20"		<b>R2AHWR20 ( )</b>	38.	
	24"		<b>R2AHWR24 ( )</b>	40.	
	30"		<b>R2AHWR30 ( )</b>	41.	
	36"		<b>R2AHWR36 ( )</b>	45.	
	42"		<b>R2AHWR42 ( )</b>	47.	
	48"		<b>R2AHWR48 ( )</b>	52.	
horizontal reveal only					
Alum horizontal reveal for between two stacking window modules	18"		<b>R2AHBW18 ( )</b>	38.	
	20"		<b>R2AHBW20 ( )</b>	38.	
	24"		<b>R2AHBW24 ( )</b>	40.	
	30"		<b>R2AHBW30 ( )</b>	41.	
	36"		<b>R2AHBW36 ( )</b>	45.	
	42"		<b>R2AHBW42 ( )</b>	47.	
	48"		<b>R2AHBW48 ( )</b>	52.	
horizontal reveal only					

Order Code	Specification Information	Application Notes										
Example: <b>R2APT3418 AA</b>	<i>To order specify pattern number including height and width as applicable.</i>	when aluminum vertical hookstrip cover installed, forfeit panel hung capability.										
<b>R2</b> Reff Generation 2		R2APT, R2AHTR and R2AHSR for use only on Reff generation 2 panels.										
<b>A</b> Aluminum												
<b>PT</b> Panel trim												
<b>34</b> for 34" h	1. Specify reveal finish AA-anodized aluminum or painted option from page 5 excluding silver	R2APT products for Reff generation 2 panels for panel side with exposed 4" h or 6" h base raceway.										
<b>18</b> for 18" w	Aluminum reveal kits for one side of tiled panel only, and include one vertical and one or more horizontal pieces. Chart below shows number of vertical to horizontal pieces for each kit by height.	Aluminum reveal kits are retrofittable to all generation 2 panels. Note for installation on generation 2 panels manufactured before January 1, 2004 it will be necessary to relocate attachment clips on the back of inserts to capture the horizontal reveal.										
<b>AA</b> Anodized aluminum	<table border="0"> <tr><td>34" h</td><td>1:1</td></tr> <tr><td>42" h</td><td>1:2</td></tr> <tr><td>49" h</td><td>1:2</td></tr> <tr><td>64" h</td><td>1:3</td></tr> <tr><td>79" h</td><td>1:4</td></tr> </table> <p>Aluminum reveal kits and hookstrip covers best suited for hard side (laminated, V1, V2 or V3) of panels only. Not recommended for fabric tiled side of panels. Recommend use on outside of stations/clusters only. Where and</p>	34" h	1:1	42" h	1:2	49" h	1:2	64" h	1:3	79" h	1:4	<p>When conditions include stacking modules (glass or other), specify vertical and horizontal pieces individually. R2APT kits are for tiled panels without stacking modules. Specify R2AHCR or R2AHCN for overall stacked height, then horizontal pieces for specific condition (between base panel inserts, between base panel and window, etc.)</p> <p>Products on this page are field installed, installation instructions and relocation clip instructions ships with kit.</p>
34" h	1:1											
42" h	1:2											
49" h	1:2											
64" h	1:3											
79" h	1:4											

description	width	height	pattern no.	AA or paint finish	list
Alum horizontal reveal for between base panel and stacking module (FL/F1/F2)	18"		<b>R2AHSR18 ( )</b>	\$38.	
	20"		<b>R2AHSR20 ( )</b>	38.	
	24"		<b>R2AHSR24 ( )</b>	40.	
	30"		<b>R2AHSR30 ( )</b>	41.	
	36"		<b>R2AHSR36 ( )</b>	45.	
	42"		<b>R2AHSR42 ( )</b>	47.	
	48"		<b>R2AHSR48 ( )</b>	52.	

horizontal reveal only

Order Code	Specification Information	Application Notes
Example: <b>R2APT3418 AA</b>	<i>To order specify pattern number including height and width as applicable.</i>	when aluminum vertical hookstrip cover installed, forfeit panel hung capability.
<b>R2</b> Reff Generation 2		
<b>A</b> Aluminum		
<b>PT</b> Panel trim		
<b>34</b> for 34"h	1. Specify reveal finish AA-anodized aluminum or painted option from page 5 excluding silver	R2APT, R2AHTR and R2AHSR for use only on Reff generation 2 panels.
<b>18</b> for 18"w		R2APT products for Reff generation 2 panels for panel side with exposed 4"h or 6"h base raceway.
<b>AA</b> Anodized aluminum	Aluminum reveal kits for one side of tiled panel only, and include one vertical and one or more horizontal pieces. Chart below shows number of vertical to horizontal pieces for each kit by height. 34"h 1:1 42"h 1:2 49"h 1:2 64"h 1:3 79"h 1:4	Aluminum reveal kits are retrofittable to all generation 2 panels. Note for installation on generation 2 panels manufactured before January 1, 2004 it will be necessary to relocate attachment clips on the back of inserts to capture the horizontal reveal.
	Aluminum reveal kits and hookstrip covers best suited for hard side (laminated, V1, V2 or V3) of panels only. Not recommended for fabric tiled side of panels. Recommend use on outside of stations/clusters only. Where and	When conditions include stacking modules (glass or other), specify vertical and horizontal pieces individually. R2APT kits are for tiled panels without stacking modules. Specify R2AHCR or R2AHCN for overall stacked height, then horizontal pieces for specific condition (between base panel inserts, between base panel and window, etc.)  Products on this page are field installed, installation instructions and relocation clip instructions ships with kit.

# Beltway one side, window panel 49" H tiled panel with glass type "A" at top

description	w	h	pattern no.	grade						
				10	15	20	30	35	40	45
Tiled, fabric both sides, Regular acoustics, Type A window on top, Beltway one side	18"	49"	<b>R3B1TFFA49 18-()</b> ( )	\$1,243.	\$1,271.	\$1,328.	\$1,395.	\$1,451.	\$1,535.	\$1,587.
	20"	49"	<b>R3B1TFFA49 20-()</b> ( )	1,243.	1,271.	1,328.	1,395.	1,451.	1,535.	1,587.
	24"	49"	<b>R3B1TFFA49 24-()</b> ( )	1,286.	1,314.	1,370.	1,438.	1,494.	1,578.	1,630.
	30"	49"	<b>R3B1TFFA49 30-()</b> ( )	1,374.	1,402.	1,459.	1,526.	1,582.	1,666.	1,718.
	36"	49"	<b>R3B1TFFA49 36-()</b> ( )	1,654.	1,682.	1,739.	1,806.	1,862.	1,946.	1,998.
	42"	49"	<b>R3B1TFFA49 42-()</b> ( )	1,802.	1,830.	1,887.	1,954.	2,010.	2,094.	2,146.
	48"	49"	<b>R3B1TFFA49 48-()</b> ( )	1,885.	1,913.	1,970.	2,037.	2,093.	2,177.	2,229.



Order Code	Specification Information	Application Notes
Example: <b>R3B1TFFA4918-A4K</b>	<i>To order please specify pattern number including:</i>	The panels on this page will accept stacking modules to increase their height on 18" to 48"W panels only.
<b>R3</b> Reff Generation 3	1. Top trim profile	6" Raceway option increases panel height by 2 3/4".
<b>B1</b> Beltway 1 side	2. Base height	
<b>T</b> Tiled panel	3. Knockout option (K = with knockouts, N = without knockouts)	Product on this page can be attached to posts 49", 64", and 79"H as well as panels 42", 49", 64" and 79"H. Panels on this page will not attach to panels made before April 1997 without an attachment kit from page 117.
<b>FF</b> Fabric on both sides	4. Panel side 1 finish (specify selection per insert)	
<b>A</b> Type A window	5. Panel side 2 finish (specify selection per insert)	Remember to specify Beltway paint finish and windowframe finish from the paint selection at the front of the price list.
<b>49</b> 49" high	6. Top trim finish	
<b>18</b> 18" wide	i) Top trim profile A,B or C options: V1, V2, V3, P1, P2, P3 finishes	79"H hookstrip reveal strips are ordered separately from page 117 at no charge.
<b>A</b> Flat style top trim profile	ii) Top trim profile E options: AA-anodized aluminum or P1, P2, P3 finish listed on page 5 excluding silver	
<b>4</b> 4" base height	7. Base finish	Note: Extruded aluminum reveal/tile dividers are not optional for between fabric inserts.
<b>K</b> Include knockouts in base	8. Beltway finish	
<b>W281</b> Fabric selection - side 1A	9. Glass window frame finish	Applicable finishes are listed on page 5 and 6.
<b>W281</b> Fabric selection - side 1B	10. Glass type Temp = Clear temp <i>Architectural options:</i> GL13 = Powder glass GL6 = Block matrix glass GL8 = Wafer glass	
<b>W281</b> Fabric selection - side 2A		
<b>W281</b> Fabric selection - side 2B		
<b>V316</b> Maple (top trim finish)		
<b>111</b> Jet Black (base finish)		
<b>111</b> Jet Black (beltway finish)		
<b>111</b> Jet Black (window frame finish)		
<b>TEMP</b> Glass option		

# Beltway one side, window panel 49" H tiled panel with glass type "B" at top

description	w	h	pattern no.	grade						
				10	15	20	30	35	40	45
Tiled, fabric both sides, Regular acoustics, Type B window on top, Beltway one side	30"	49"	<b>R3B1TFFB49 30-()</b> ( )	\$1,482.	\$1,510.	\$1,567.	\$1,634.	\$1,690.	\$1,774.	\$1,826.
	36"	49"	<b>R3B1TFFB49 36-()</b> ( )	1,771.	1,799.	1,856.	1,923.	1,979.	2,063.	2,115.
	42"	49"	<b>R3B1TFFB49 42-()</b> ( )	1,918.	1,946.	2,003.	2,070.	2,126.	2,210.	2,262.
	48"	49"	<b>R3B1TFFB49 48-()</b> ( )	2,010.	2,038.	2,095.	2,162.	2,218.	2,302.	2,354.

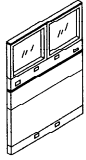

Order Code	Specification Information	Application Notes
Example: <b>R3B1TFFB4930-A4K</b>	<i>To order please specify pattern number including:</i>	<i>1. Top trim profile:</i>
<b>R3</b> Reff Generation 3		A = Flat
<b>B1</b> Beltway one side		B = Square
<b>T</b> Tiled panel		C = Bullnose
<b>FF</b> Fabric both sides		E = Extruded Aluminum
<b>B</b> Type B window		2. Base height:
<b>49</b> 49" high		4 = 4" base height
<b>30</b> 30" wide		6 = 6" base height (add \$47 per panel for this option)
<b>A</b> Flat style top trim profile		The panels on this page will accept stacking modules to increase their height on 18" to 48"W panels only.
<b>4</b> 4" base height		6" Raceway option increases panel height by 2 3/4".
<b>K</b> Include knockouts in base		Product on this page can be attached to posts 49", 64", and 79"H as well as panels 42", 49", 64" and 79"H. Panels on this page will not attach to panels made before April 1997 without an attachment kit from page 117.
<b>B</b> Tile divider, black reveal		Remember to specify Beltway paint finish, glass type and windowframe finish from the paint selection at the front of the price list.
<b>W281</b> Fabric selection - side 1A		79"H hookstrip reveal strips are ordered separately from page 117 at no charge.
<b>W281</b> Fabric selection - side 1B		Applicable finishes are listed on page 5 and 6.
<b>W281</b> Fabric selection - side 2A		
<b>W281</b> Fabric selection - side 2B		
<b>Y328</b> Mahogany - side 2 tiled		
<b>V316</b> Maple (top trim finish)		
<b>111</b> Jet Black (base finish)		
<b>111</b> Jet Black (beltway finish)		
<b>111</b> Jet Black (window frame finish)		
<b>TEMP</b> Glass option		

# Beltway one side, window panel 49" H monolithic with glass at top

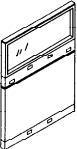
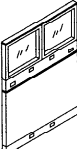
description	w	h	pattern no.	grade						
				10	15	20	30	35	40	45
Monolithic, fabric both sides, Type A window on top, Beltway one side 	18"	49"	<b>R3B1PFFA49 18-()</b> ( )	\$1,122.	\$1,140.	\$1,180.	\$1,263.	\$1,315.	\$1,391.	\$1,467.
	20"	49"	<b>R3B1PFFA49 20-()</b> ( )	1,122.	1,140.	1,180.	1,263.	1,315.	1,391.	1,467.
	24"	49"	<b>R3B1PFFA49 24-()</b> ( )	1,162.	1,180.	1,220.	1,303.	1,355.	1,431.	1,507.
	30"	49"	<b>R3B1PFFA49 30-()</b> ( )	1,238.	1,256.	1,296.	1,379.	1,431.	1,507.	1,583.
	36"	49"	<b>R3B1PFFA49 36-()</b> ( )	1,474.	1,492.	1,532.	1,615.	1,667.	1,743.	1,819.
	42"	49"	<b>R3B1PFFA49 42-()</b> ( )	1,600.	1,618.	1,658.	1,741.	1,793.	1,869.	1,945.
	48"	49"	<b>R3B1PFFA49 48-()</b> ( )	1,676.	1,694.	1,734.	1,817.	1,869.	1,945.	2,021.
Monolithic, fabric both sides, Type B window on top, Beltway one side 	30"	49"	<b>R3B1PFFB49 30-()</b> ( )	1,346.	1,364.	1,404.	1,487.	1,539.	1,615.	1,691.
	36"	49"	<b>R3B1PFFB49 36-()</b> ( )	1,591.	1,609.	1,649.	1,732.	1,784.	1,860.	1,936.
	42"	49"	<b>R3B1PFFB49 42-()</b> ( )	1,716.	1,734.	1,774.	1,857.	1,909.	1,985.	2,061.
	48"	49"	<b>R3B1PFFB49 48-()</b> ( )	1,801.	1,819.	1,859.	1,942.	1,994.	2,070.	2,146.

Order Code	Specification Information	Application Notes
Example: <b>R3B1PFFA4918-A4K</b>	<i>To order please specify pattern number including:</i>	The panels on this page will accept stacking modules to increase their height on 18" to 48"W panels only.
<b>R3</b> Reff Generation 3	1. Top trim profile	6" Raceway option increases panel height by 2 <sup>3</sup> / <sub>4</sub> ".
<b>B1</b> Beltway 1 side	2. Base height	
<b>P</b> Monolithic panel	3. Knockout option (K = with knockouts, N = without knockouts)	Product on this page can be attached to posts 49", 64", and 79"H as well as panels 42", 49", 64" and 79"H. Panels on this page will not attach to panels made before April 1997 without an attachment kit from page 117.
<b>FF</b> Fabric on both sides	4. Panel side 1 finish (specify selection per insert)	
<b>A</b> Type A window	5. Panel side 2 finish (specify selection per insert)	Remember to specify Beltway paint finish and windowframe finish from the paint selection at the front of the price list.
<b>49</b> 49" high	6. Top trim finish	
<b>18</b> 18" wide	i) Top trim profile A,B or C options: V1, V2, V3, P1, P2, P3 finishes	79"H hookstrip reveal strips are ordered separately from page 117 at no charge.
<b>A</b> Flat style top trim profile	ii) Top trim profile E options: AA-anodized aluminum or P1, P2, P3 finish listed on page 5 excluding silver	
<b>4</b> 4" base height	7. Base finish	Note: Extruded aluminum reveal/tile dividers are not optional for between fabric inserts.
<b>K</b> Include knockouts in base	8. Beltway finish	
<b>W281</b> Fabric selection - side 1	9. Glass window frame finish	Applicable finishes are listed on page 5 and 6.
<b>W281</b> Fabric selection - side 2	10. Glass type Temp = Clear temp <i>Architectural options:</i> GL13 = Powder glass GL6 = Block matrix glass GL8 = Wafer glass	
<b>V316</b> Maple (top trim finish)		
<b>111</b> Jet Black (base finish)		
<b>111</b> Jet Black (beltway finish)		
<b>111</b> Jet Black (window frame finish)		
<b>TEMP</b> Glass option		
	1. <i>Top trim profile:</i> A = Flat B = Square C = Bullnose E = Extruded Aluminum  2. <i>Base height:</i> 4 = 4" base height 6 = 6" base height (add \$47 per panel for this option)	
		Add upcharge for architectural glass: (as applicable by width) Width Add 18" \$86 20" \$86 24" \$101 30" \$121 36" \$145 42" \$173 48" \$198  Add to all products on this page: upcharge of \$35 per panel for P2 paint class options or \$63 per panel for P3 paint class options.

Beltway one side, window panel 49" H  
 tiled with glass type "A" at top,  
 fabric one side, laminate other side

description	w	h	pattern no.	grade						
				10	15	20	30	35	40	45
Tiled, fabric one side, Regular acoustics, Type A window on top, Beltway one side (fabric side)	18"	49"	<b>R3B1TFLA49 18-()</b> ( )	\$1,376.	\$1,390.	\$1,422.	\$1,454.	\$1,482.	\$1,524.	\$1,563.
	20"	49"	<b>R3B1TFLA49 20-()</b> ( )	1,376.	1,390.	1,422.	1,454.	1,482.	1,524.	1,563.
	24"	49"	<b>R3B1TFLA49 24-()</b> ( )	1,420.	1,434.	1,466.	1,498.	1,526.	1,568.	1,607.
	30"	49"	<b>R3B1TFLA49 30-()</b> ( )	1,510.	1,524.	1,556.	1,588.	1,616.	1,658.	1,697.
	36"	49"	<b>R3B1TFLA49 36-()</b> ( )	1,794.	1,808.	1,840.	1,872.	1,900.	1,942.	1,981.
	42"	49"	<b>R3B1TFLA49 42-()</b> ( )	1,942.	1,956.	1,988.	2,020.	2,048.	2,090.	2,129.
	48"	49"	<b>R3B1TFLA49 48-()</b> ( )	2,031.	2,045.	2,077.	2,109.	2,137.	2,179.	2,218.

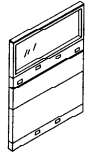

Order Code	Specification Information	Application Notes
Example: <b>R3B1TFLA4918-A4K</b>	<i>To order please specify pattern number including:</i>	<i>1. Top trim profile:</i>
<b>R3</b> Reff Generation 3		A = Flat
<b>B1</b> Beltway one side	1. Top trim profile	B = Square
<b>T</b> Tiled panel	2. Base height	C = Bullnose
<b>FL</b> Fabric BW side, laminate other	3. Knockout option (K = with knockouts, N = without knockouts)	E = Extruded Aluminum
<b>A</b> Type A window	4. Tile divider (where optional) B = black steel divider or specify AA-anodized aluminum or painted option excluding silver from page 5 for extruded aluminum divider (upcharge applicable, optional "tiled" style products only)	2. Base height: 4 = 4" base height 6 = 6" base height (add \$47 per panel for this option)
<b>49</b> 49" high	5. Fabric side, finish (specify selection per insert; bottom up.)	The panels on this page will accept stacking modules to increase their height on 18" to 48"W panels only.
<b>18</b> 18" wide	6. Laminate side finish (specify selection per insert; bottom up.)	6" Raceway option increases panel height by 2 3/4".
<b>A</b> Flat style top trim profile	7. Top trim finish i) Top trim profile A,B or C options: V1, V2, V3, P1, P2, P3 finishes ii) Top trim profile E options: AA-anodized aluminum or P1, P2, P3 finish listed on page 5 excluding silver	Product on this page can be attached to posts 49", 64", and 79"H as well as panels 42", 49", 64" and 79"H. Panels on this page will not attach to panels made before April 1997 without an attachment kit from page 117.
<b>4</b> 4" base height	8. Base finish	Remember to specify Beltway paint finish, glass type and window frame finish from the paint selection at the front of the price list.
<b>K</b> Include knockouts in base	9. Beltway finish	79"H hookstrip reveal strips are ordered separately from page 117 at no charge.
<b>B</b> Tile divider, black reveal	10. Window frame finish	Applicable finishes are listed on page 5 and 6.
<b>W281</b> Fabric selection - side 1A	11. Glass option Temp = Clear temp <i>Architectural options:</i> GL13 = Powder glass GL6 = Block matrix glass GL8 = Wafer glass	Add upcharge for architectural glass: (as applicable by width)
<b>W281</b> Fabric selection - side 1B		Width Add 18" \$86 20" \$86 24" \$101 30" \$121 36" \$145 42" \$173 48" \$198
<b>114</b> Folkstone grey - side 2A		Frame finish: Add to all products on this page: upcharge of \$35 per panel for P2 paint class options or \$63 per panel for P3 paint class options.
<b>114</b> Folkstone grey - side 2B		Add upcharge for extruded aluminum reveal/tile divider: (as applicable by width) Optional non fabric tiled side only, fabric side always black
<b>V316</b> Maple (top trim finish)		Width Add 18" \$14 20" \$14 24" \$15 30" \$15 36" \$16 42" \$16 48" \$21
<b>111</b> Jet Black (base finish)		Product on this page will accept wood grain laminate where laminate is currently an option. Panel product is subject to a 10% upcharge on the base panel price. Refer to panel product upcharge table.
<b>111</b> Jet Black (beltway finish)		
<b>111</b> Jet Black (window frame finish)		
<b>TEMP</b> Glass option		

Beltway one side, window panel 49" H  
 tiled with glass type "B" at top,  
 fabric one side, laminate other side

description	w	h	pattern no.	grade						
				10	15	20	30	35	40	45
Tiled, fabric one side, Regular acoustics, Type B window on top, Beltway one side (fabric side)	30"	49"	<b>R3B1TFLB49 30-()</b> ( )	\$1,622.	\$1,636.	\$1,668.	\$1,700.	\$1,728.	\$1,770.	\$1,809.
	36"	49"	<b>R3B1TFLB49 36-()</b> ( )	1,911.	1,925.	1,957.	1,989.	2,017.	2,059.	2,098.
	42"	49"	<b>R3B1TFLB49 42-()</b> ( )	2,059.	2,073.	2,105.	2,137.	2,165.	2,207.	2,246.
	48"	49"	<b>R3B1TFLB49 48-()</b> ( )	2,158.	2,172.	2,204.	2,236.	2,264.	2,306.	2,345.

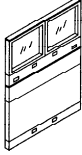

Order Code	Specification Information	Application Notes
Example: <b>R3B1TFLB4918-A4K</b>	<i>To order please specify pattern number including:</i>	<i>1. Top trim profile:</i>
<b>R3</b> Reff Generation 3		A = Flat
<b>B1</b> Beltway one side	1. Top trim profile	B = Square
<b>T</b> Tiled panel	2. Base height	C = Bullnose
<b>FL</b> Fabric BW side, laminate other	3. Knockout option (K = with knockouts, N = without knockouts)	E = Extruded Aluminum
<b>B</b> Type B window	4. Tile divider (where optional) B = black steel divider or specify AA-anodized aluminum or painted option excluding silver from page 5 for extruded aluminum divider (upcharge applicable, optional "tiled" style products only)	2. Base height: 4 = 4" base height 6 = 6" base height (add \$47 per panel for this option)
<b>49</b> 49" high		The panels on this page will accept stacking modules to increase their height on 18" to 48"W panels only.
<b>18</b> 18" wide		6" Raceway option increases panel height by 2 3/4".
<b>A</b> Flat style top trim profile	5. Fabric side, finish (specify selection per insert; bottom up.)	Product on this page can be attached to posts 49", 64", and 79"H as well as panels 42", 49", 64" and 79"H. Panels on this page will not attach to panels made before April 1997 without an attachment kit from page 117.
<b>4</b> 4" base height	6. Laminate side finish (specify selection per insert; bottom up.)	Remember to specify Beltway paint finish, glass type and window frame finish from the paint selection at the front of the price list.
<b>K</b> Include knockouts in base	7. Top trim finish i) Top trim profile A,B or C options: V1, V2, V3, P1, P2, P3 finishes ii) Top trim profile E options: AA-anodized aluminum or P1, P2, P3 finish listed on page 5 excluding silver	79"H hookstrip reveal strips are ordered separately from page 117 at no charge.
<b>B</b> Tile divider, black reveal	8. Base finish	Applicable finishes are listed on page 5 and 6.
<b>W281</b> Fabric selection - side 1A	9. Beltway finish	
<b>W281</b> Fabric selection - side 1B	10. Window frame finish	
<b>114</b> Folkstone grey - side 2A	11. Glass option Temp = Clear temp <i>Architectural options:</i> GL13 = Powder glass GL6 = Block matrix glass GL8 = Wafer glass	
<b>114</b> Folkstone grey - side 2B		
<b>V316</b> Maple (top trim finish)		
<b>111</b> Jet Black (base finish)		
<b>111</b> Jet Black (beltway finish)		
<b>111</b> Jet Black (window frame finish)		
<b>TEMP</b> Glass option		



Beltway one side, window panel 49" H  
 monolithic with glass at top,  
 fabric one side, laminate other side

description	w	h	pattern no.	grade						
				10	15	20	30	35	40	45
Monolithic, fabric one side, Type A window on top, Beltway one side (fabric side)	18"	49"	<b>R3B1PFLA49 18-()</b> ( )	\$1,137.	\$1,146.	\$1,167.	\$1,209.	\$1,235.	\$1,274.	\$1,300.
	20"	49"	<b>R3B1PFLA49 20-()</b> ( )	1,137.	1,146.	1,167.	1,209.	1,235.	1,274.	1,300.
	24"	49"	<b>R3B1PFLA49 24-()</b> ( )	1,196.	1,205.	1,226.	1,268.	1,294.	1,333.	1,359.
	30"	49"	<b>R3B1PFLA49 30-()</b> ( )	1,303.	1,312.	1,333.	1,375.	1,401.	1,440.	1,466.
	36"	49"	<b>R3B1PFLA49 36-()</b> ( )	1,573.	1,582.	1,603.	1,645.	1,671.	1,710.	1,736.
	42"	49"	<b>R3B1PFLA49 42-()</b> ( )	1,729.	1,738.	1,759.	1,801.	1,827.	1,866.	1,892.
	48"	49"	<b>R3B1PFLA49 48-()</b> ( )	1,839.	1,848.	1,869.	1,911.	1,937.	1,976.	2,002.

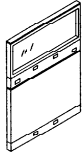

Monolithic, fabric one side, Type B window on top, Beltway one side (fabric side)	30"	49"	<b>R3B1PFLB49 30-()</b> ( )	1,415.	1,424.	1,445.	1,487.	1,513.	1,552.	1,578.
	36"	49"	<b>R3B1PFLB49 36-()</b> ( )	1,690.	1,699.	1,720.	1,762.	1,788.	1,827.	1,853.
	42"	49"	<b>R3B1PFLB49 42-()</b> ( )	1,846.	1,855.	1,876.	1,918.	1,944.	1,983.	2,009.
	48"	49"	<b>R3B1PFLB49 48-()</b> ( )	1,966.	1,975.	1,996.	2,038.	2,064.	2,103.	2,129.

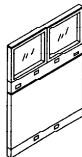

Order Code	Specification Information	Application Notes
Example: <b>R3B1PFLA4918-A4K</b>	<i>To order please specify pattern number including:</i>	<i>1. Top trim profile:</i>
<b>R3</b> Reff Generation 3	1. Top trim profile	A = Flat
<b>B1</b> Beltway one side	2. Base height	B = Square
<b>P</b> Monolithic panel	3. Knockout option (K = with knockouts, N = without knockouts)	C = Bullnose
<b>FL</b> Fabric BW side, laminate other	4. Tile divider (where optional) B = black steel divider or specify AA-anodized aluminum or painted option excluding silver from page 5 for extruded aluminum divider (upcharge applicable, optional "tiled" style products only)	E = Extruded Aluminum
<b>A</b> Type A window	5. Fabric side, finish (specify selection per insert; bottom up.)	2. Base height:
<b>49</b> 49" high	6. Laminate side finish (specify selection per insert; bottom up.)	4 = 4" base height
<b>18</b> 18" wide	7. Top trim finish	6 = 6" base height (add \$47 per panel for this option)
<b>A</b> Flat style top trim profile	i) Top trim profile A,B or C options: V1, V2, V3, P1, P2, P3 finishes	The panels on this page will accept stacking modules to increase their height on 18" to 48"W panels only.
<b>4</b> 4" base height	ii) Top trim profile E options: AA-anodized aluminum or P1, P2, P3 finish listed on page 5 excluding silver	6" Raceway option increases panel height by 2 3/4".
<b>K</b> Include knockouts in base	8. Base finish	Product on this page can be attached to posts 49", 64", and 79"H as well as panels 42", 49", 64" and 79"H. Panels on this page will not attach to panels made before April 1997 without an attachment kit from page 117.
<b>B</b> Tile divider, black reveal	9. Beltway finish	Remember to specify Beltway paint finish, glass type and windowframe finish from the paint selection at the front of the price list.
<b>W281</b> Fabric selection - side 1	10. Window frame finish	79"H hookstrip reveal strips are ordered separately from page 117 at no charge.
<b>114</b> Folkstone grey - side 2	11. Glass option	Applicable finishes are listed on page 5 and 6.
<b>V316</b> Maple (top trim finish)	Temp = Clear temp	
<b>111</b> Jet Black (base finish)	<i>Architectural options:</i>	
<b>111</b> Jet Black (beltway finish)	GL13 = Powder glass	
<b>111</b> Jet Black (window frame finish)	GL6 = Block matrix glass	
<b>TEMP</b> Glass option	GL8 = Wafer glass	

Add upcharge for architectural glass: (as applicable by width)

Width	Add
18"	\$86
20"	\$86
24"	\$101
30"	\$121
36"	\$145
42"	\$173
48"	\$198

Frame finish:  
 Add to all products on this page: upcharge of \$35 per panel for P2 paint class options or \$63 per panel for P3 paint class options.

Add upcharge for extruded aluminum reveal/tile divider: (as applicable by width)  
 Optional non fabric tiled side only, fabric side always black

Width	Add
18"	\$14
20"	\$14
24"	\$15
30"	\$15
36"	\$16
42"	\$16
48"	\$21

Product on this page will accept wood grain laminate where laminate is currently an option.  
 Panel product is subject to a 10% upcharge on the base panel price. Refer to panel product upcharge table.

Beltway one side, window panel 49" H  
 tiled with type "A" glass at top,  
 fabric one side, techwood other side

description	w	h	pattern no.	grade						
				10	15	20	30	35	40	45
Tiled, fabric one side, Regular acoustics, Type A window on top, Beltway one side (fabric side)	18"	49"	<b>R3B1TF1A49 18-()</b> ( )	\$1,399.	\$1,413.	\$1,445.	\$1,477.	\$1,505.	\$1,547.	\$1,586.
	20"	49"	<b>R3B1TF1A49 20-()</b> ( )	1,399.	1,413.	1,445.	1,477.	1,505.	1,547.	1,586.
	24"	49"	<b>R3B1TF1A49 24-()</b> ( )	1,447.	1,461.	1,493.	1,525.	1,553.	1,595.	1,634.
	30"	49"	<b>R3B1TF1A49 30-()</b> ( )	1,537.	1,551.	1,583.	1,615.	1,643.	1,685.	1,724.
	36"	49"	<b>R3B1TF1A49 36-()</b> ( )	1,827.	1,841.	1,873.	1,905.	1,933.	1,975.	2,014.
	42"	49"	<b>R3B1TF1A49 42-()</b> ( )	1,979.	1,993.	2,025.	2,057.	2,085.	2,127.	2,166.
	48"	49"	<b>R3B1TF1A49 48-()</b> ( )	2,066.	2,080.	2,112.	2,144.	2,172.	2,214.	2,253.

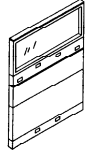

Order Code	Specification Information	Application Notes
Example: <b>R3B1TF1A4918-A4K</b>	<i>To order please specify pattern number including:</i>	<i>1. Top trim profile:</i>
<b>R3</b> Reff Generation 3		A = Flat
<b>B1</b> Beltway one side	1. Top trim profile	B = Square
<b>T</b> Tiled panel	2. Base height	C = Bullnose
<b>F1</b> Fabric one side, V1 other	3. Knockout option (K = with knockouts, N = without knockouts)	E = Extruded Aluminum
<b>A</b> Type A window	4. Tile divider (where optional) B = black steel divider or specify AA-anodized aluminum or painted option excluding silver from page 5 for extruded aluminum divider (upcharge applicable, optional "tiled" style products only)	2. Base height: 4 = 4" base height 6 = 6" base height (add \$47 per panel for this option)
<b>49</b> 49" high		The panels on this page will accept stacking modules to increase their height on 18" to 48"W panels only.
<b>18</b> 18" wide		6" Raceway option increases panel height by 2 3/4".
<b>A</b> Flat style top trim profile		Product on this page can be attached to posts 49", 64", and 79"H as well as panels 42", 49", 64" and 79"H. Panels on this page will not attach to panels made before April 1997 without an attachment kit from page 117.
<b>4</b> 4" base height		Remember to specify Beltway paint finish, glass type and window frame finish from the paint selection at the front of the price list.
<b>K</b> Include knockouts in base	5. Fabric side, finish (specify selection per insert; bottom up.)	79"H hookstrip reveal strips are ordered separately from page 117 at no charge.
<b>B</b> Tile divider, black reveal	6. Techwood side, finish (specify one V1 finish for side)	Applicable finishes are listed on page 5 and 6.
<b>W281</b> Fabric selection - side 1A	7. Top trim finish i) Top trim profile A,B or C options: V1, V2, V3, P1, P2, P3 finishes ii) Top trim profile E options: AA-anodized aluminum or P1, P2, P3 finish listed on page 5 excluding silver	
<b>W281</b> Fabric selection - side 1B	8. Base finish	
<b>Y328</b> Mahogany - side 2 tiled	9. Beltway finish	
<b>V316</b> Maple (top trim finish)	10. Window frame finish	
<b>111</b> Jet Black (base finish)	11. Glass option Temp = Clear temp	
<b>111</b> Jet Black (beltway finish)	<i>Architectural options:</i> GL13 = Powder glass GL6 = Block matrix glass GL8 = Wafer glass	
<b>111</b> Jet Black (window frame finish)		
<b>TEMP</b> Glass option		

Beltway one side, window panel 49" H  
 tiled with type "B" glass at top,  
 fabric one side, techwood other side

Panels

description	w	h	pattern no.	grade						
				10	15	20	30	35	40	45
Tiled, fabric one side, Regular acoustics, Type B window on top, Beltway one side (fabric side)	30"	49"	<b>R3B1TF1B49 30-()</b> ( )	\$1,649.	\$1,663.	\$1,695.	\$1,727.	\$1,755.	\$1,797.	\$1,836.
	36"	49"	<b>R3B1TF1B49 36-()</b> ( )	1,944.	1,958.	1,990.	2,022.	2,050.	2,092.	2,131.
	42"	49"	<b>R3B1TF1B49 42-()</b> ( )	2,096.	2,110.	2,142.	2,174.	2,202.	2,244.	2,283.
	48"	49"	<b>R3B1TF1B49 48-()</b> ( )	2,193.	2,207.	2,239.	2,271.	2,299.	2,341.	2,380.

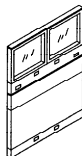

Order Code	Specification Information	Application Notes
Example: <b>R3B1TF1B4930-A4K</b>	<i>To order please specify pattern number including:</i>	<i>1. Top trim profile:</i>
<b>R3</b> Reff Generation 3		A = Flat
<b>B1</b> Beltway one side	1. Top trim profile	B = Square
<b>T</b> Tiled panel	2. Base height	C = Bullnose
<b>F1</b> Fabric one side, V1 other	3. Knockout option (K = with knockouts, N = without knockouts)	E = Extruded Aluminum
<b>B</b> Type B window	4. Tile divider (where optional) B = black steel divider or specify AA-anodized aluminum or painted option excluding silver from page 5 for extruded aluminum divider (upcharge applicable, optional "tiled" style products only)	2. Base height: 4 = 4" base height 6 = 6" base height (add \$47 per panel for this option)
<b>49</b> 49" high		The panels on this page will accept stacking modules to increase their height on 18" to 48"W panels only.
<b>30</b> 30" wide		6" Raceway option increases panel height by 2 3/4".
<b>A</b> Flat style top trim profile		Product on this page can be attached to posts 49", 64", and 79"H as well as panels 42", 49", 64" and 79"H. Panels on this page will not attach to panels made before April 1997 without an attachment kit from page 117.
<b>4</b> 4" base height		Remember to specify Beltway paint finish, glass type and windowframe finish from the paint selection at the front of the price list.
<b>K</b> Include knockouts in base	5. Fabric side, finish (specify selection per insert; bottom up.)	
<b>B</b> Tile divider, black reveal	6. Techwood side, finish (specify one V1 finish for side)	Frame finish: Add to all products on this page: upcharge of \$35 per panel for P2 paint class options or \$63 per panel for P3 paint class options.
<b>W281</b> Fabric selection - side 1A	7. Top trim finish i) Top trim profile A,B or C options: V1, V2, V3, P1, P2, P3 finishes ii) Top trim profile E options: AA-anodized aluminum or P1, P2, P3 finish listed on page 5 excluding silver	Add upcharge for extruded aluminum reveal/tile divider: (as applicable by width) Optional non fabric tiled side only, fabric side always black
<b>W281</b> Fabric selection - side 1B		
<b>Y328</b> Mahogany - side 2 tiled	8. Base finish	Width Add 18" \$86 20" \$86 24" \$101 30" \$121 36" \$145 42" \$173 48" \$198
<b>V316</b> Maple (top trim finish)	9. Beltway finish	
<b>111</b> Jet Black (base finish)	10. Window frame finish	
<b>111</b> Jet Black (beltway finish)	11. Glass option Temp = Clear temp Architectural options: GL13 = Powder glass GL6 = Block matrix glass GL8 = Wafer glass	79"H hookstrip reveal strips are ordered separately from page 117 at no charge. Applicable finishes are listed on page 5 and 6.
<b>111</b> Jet Black (window frame finish)		
<b>TEMP</b> Glass option		

Beltway one side, window panel 49" H  
*monolithic with glass at top,*  
*fabric one side, techwood other side*

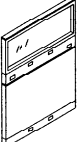
description	w	h	pattern no.	grade						
				10	15	20	30	35	40	45
Monolithic, fabric one side, Type A window on top, Beltway one side (fabric side) 	18"	49"	<b>R3B1PF1A49 18-()</b> ( )	\$1,159.	\$1,168.	\$1,189.	\$1,231.	\$1,257.	\$1,296.	\$1,322.
	20"	49"	<b>R3B1PF1A49 20-()</b> ( )	1,159.	1,168.	1,189.	1,231.	1,257.	1,296.	1,322.
	24"	49"	<b>R3B1PF1A49 24-()</b> ( )	1,216.	1,225.	1,246.	1,288.	1,314.	1,353.	1,379.
	30"	49"	<b>R3B1PF1A49 30-()</b> ( )	1,324.	1,333.	1,354.	1,396.	1,422.	1,461.	1,487.
	36"	49"	<b>R3B1PF1A49 36-()</b> ( )	1,598.	1,607.	1,628.	1,670.	1,696.	1,735.	1,761.
	42"	49"	<b>R3B1PF1A49 42-()</b> ( )	1,762.	1,771.	1,792.	1,834.	1,860.	1,899.	1,925.
	48"	49"	<b>R3B1PF1A49 48-()</b> ( )	1,869.	1,878.	1,899.	1,941.	1,967.	2,006.	2,032.

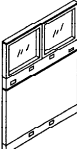
Monolithic, fabric one side, Type B window on top, Beltway one side (fabric side) 	30"	49"	<b>R3B1PF1B49 30-()</b> ( )	1,436.	1,445.	1,466.	1,508.	1,534.	1,573.	1,599.
	36"	49"	<b>R3B1PF1B49 36-()</b> ( )	1,715.	1,724.	1,744.	1,787.	1,813.	1,852.	1,878.
	42"	49"	<b>R3B1PF1B49 42-()</b> ( )	1,879.	1,888.	1,909.	1,951.	1,977.	2,016.	2,042.
	48"	49"	<b>R3B1PF1B49 48-()</b> ( )	1,996.	2,005.	2,026.	2,068.	2,094.	2,133.	2,158.

Order Code	Specification Information	Application Notes
Example: <b>R3B1PF1B4930-A4K</b>	<i>To order please specify pattern number including:</i>	<i>1. Top trim profile:</i>
<b>R3</b> Reff Generation 3		A = Flat
<b>B1</b> Beltway one side	1. Top trim profile	B = Square
<b>P</b> Monolithic panel	2. Base height	C = Bullnose
<b>F1</b> Fabric one side, V1 other	3. Knockout option (K = with knockouts, N = without knockouts)	E = Extruded Aluminum
<b>B</b> Type B window	4. Tile divider (where optional) B = black steel divider or specify AA-anodized aluminum or painted option excluding silver from page 5 for extruded aluminum divider (upcharge applicable, optional "tiled" style products only)	2. Base height: 4 = 4" base height 6 = 6" base height (add \$47 per panel for this option)
<b>49</b> 49" high		The panels on this page will accept stacking modules to increase their height on 18" to 48"W panels only.
<b>30</b> 30" wide		6" Raceway option increases panel height by 2 3/4".
<b>A</b> Flat style top trim profile		
<b>4</b> 4" base height		
<b>K</b> Include knockouts in base	5. Fabric side, finish (specify selection per insert; bottom up.)	Product on this page can be attached to posts 49", 64", and 79"H as well as panels 42", 49", 64" and 79"H. Panels on this page will not attach to panels made before April 1997 without an attachment kit from page 117.
<b>B</b> Tile divider, black reveal	6. Techwood side, finish (specify one V1 finish for side)	Remember to specify Beltway paint finish, glass type and window frame finish from the paint selection at the front of the price list.
<b>W281</b> Fabric selection - side 1	7. Top trim finish	
<b>Y328</b> Mahogany - side 2	i) Top trim profile A,B or C options: V1, V2, V3, P1, P2, P3 finishes	
<b>V316</b> Maple (top trim finish)	ii) Top trim profile E options: AA-anodized aluminum or P1, P2, P3 finish listed on page 5 excluding silver	
<b>111</b> Jet Black (base finish)	8. Base finish	
<b>111</b> Jet Black (beltway finish)	9. Beltway finish	
<b>111</b> Jet Black (window frame finish)	10. Window frame finish	79"H hookstrip reveal strips are ordered separately from page 117 at no charge.
<b>TEMP</b> Glass option	11. Glass option Temp = Clear temp <i>Architectural options:</i> GL13 = Powder glass GL6 = Block matrix glass GL8 = Wafer glass	Applicable finishes are listed on page 5 and 6.

Add upcharge for architectural glass: (as applicable by width)

Width	Add
18"	\$86
20"	\$86
24"	\$101
30"	\$121
36"	\$145
42"	\$173
48"	\$198

Frame finish:  
 Add to all products on this page: upcharge of \$35 per panel for P2 paint class options or \$63 per panel for P3 paint class options.

Add upcharge for extruded aluminum reveal/tile divider: (as applicable by width)  
*Optional non fabric tiled side only, fabric side always black*

Width	Add
18"	\$14
20"	\$14
24"	\$15
30"	\$15
36"	\$16
42"	\$16
48"	\$21

Beltway one side, window panel 49" H  
 tiled with type "A" glass at top,  
 fabric one side, conventional veneer other side

Panels

description	w	h	pattern no.	grade						
				10	15	20	30	35	40	45
Tiled, fabric one side, Regular acoustics, Type A window on top, Beltway one side (fabric side)	18"	49"	<b>R3B1TF2A49 18-()</b> ( )	\$1,425.	\$1,439.	\$1,471.	\$1,503.	\$1,531.	\$1,573.	\$1,612.
	20"	49"	<b>R3B1TF2A49 20-()</b> ( )	1,425.	1,439.	1,471.	1,503.	1,531.	1,573.	1,612.
	24"	49"	<b>R3B1TF2A49 24-()</b> ( )	1,471.	1,485.	1,517.	1,549.	1,577.	1,619.	1,658.
	30"	49"	<b>R3B1TF2A49 30-()</b> ( )	1,562.	1,576.	1,608.	1,640.	1,668.	1,710.	1,749.
	36"	49"	<b>R3B1TF2A49 36-()</b> ( )	1,855.	1,869.	1,901.	1,933.	1,961.	2,003.	2,042.
	42"	49"	<b>R3B1TF2A49 42-()</b> ( )	2,010.	2,024.	2,056.	2,088.	2,116.	2,158.	2,197.
	48"	49"	<b>R3B1TF2A49 48-()</b> ( )	2,101.	2,115.	2,147.	2,179.	2,207.	2,249.	2,288.

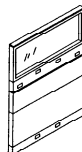

Order Code	Specification Information	Application Notes
Example: <b>R3B1TF2A4918-A4K</b>	<i>To order please specify pattern number including:</i>	<i>1. Top trim profile:</i>
<b>R3</b> Reff Generation 3		A = Flat
<b>B1</b> Beltway one side		B = Square
<b>T</b> Tiled panel		C = Bullnose
<b>F2</b> Fabric one side, V2 other	1. Top trim profile	E = Extruded Aluminum
<b>A</b> Type A window	2. Base height	2. Base height:
<b>49</b> 49" high	3. Knockout option	4 = 4" base height
<b>18</b> 18" wide	(K = with knockouts, N = without knockouts)	6 = 6" base height (add \$47 per panel for this option)
<b>A</b> Flat style top trim profile	4. Tile divider (where optional)	The panels on this page will accept stacking modules to increase their height on 18" to 48"W panels only.
<b>4</b> 4" base height	B = black steel divider or specify AA-anodized aluminum or painted option excluding silver from page 5 for extruded aluminum divider (upcharge applicable, optional "tiled" style products only)	6" Raceway option increases panel height by 2 3/4".
<b>K</b> Include knockouts in base	5. Fabric side, finish (specify selection per insert; bottom up.)	Product on this page can be attached to posts 49", 64", and 79"H as well as panels 42", 49", 64" and 79"H. Panels on this page will not attach to panels made before April 1997 without an attachment kit from page 117.
<b>B</b> Tile divider, black reveal	6. Conventional veneer side, finish (specify one V2 finish for side)	Remember to specify Beltway paint finish, glass type and windowframe finish from the paint selection at the front of the price list.
<b>W281</b> Fabric selection - side 1A	7. Top trim finish	79"H hookstrip reveal strips are ordered separately from page 117 at no charge.
<b>W281</b> Fabric selection - side 1B	i) Top trim profile A,B or C options:	Applicable finishes are listed on page 5 and 6.
<b>V316</b> Maple surface - side 2 tiled	V1, V2, V3, P1, P2, P3 finishes	
<b>V316</b> Maple (top trim finish)	ii) Top trim profile E options:	
<b>111</b> Jet Black (base finish)	AA-anodized aluminum or P1, P2, P3 finish listed on page 5 excluding silver	
<b>111</b> Jet Black (beltway finish)	8. Base finish	
<b>111</b> Jet Black (window frame finish)	9. Beltway finish	
<b>TEMP</b> Glass option	10. Window frame finish	
	11. Glass option	
	Temp = Clear temp	
	<i>Architectural options:</i>	
	GL13 = Powder glass	
	GL6 = Block matrix glass	
	GL8 = Wafer glass	

Add upcharge for architectural glass: (as applicable by widths)

Width	Add
18"	\$86
20"	\$86
24"	\$101
30"	\$121
36"	\$145
42"	\$173
48"	\$198

Frame finish:  
 Add to all products on this page: upcharge of \$35 per panel for P2 paint class options or \$63 per panel for P3 paint class options.

Add upcharge for extruded aluminum reveal/tile divider: (as applicable by width)  
 Optional non fabric tiled side only, fabric side always black

Width	Add
18"	\$14
20"	\$14
24"	\$15
30"	\$15
36"	\$16
42"	\$16
48"	\$21

Beltway one side, window panel 49" H  
 tiled with type "B" glass at top,  
 fabric one side, conventional veneer other side

description	w	h	pattern no.	grade						
				10	15	20	30	35	40	45
Tiled, fabric one side, Regular acoustics, Type B window on top, Beltway one side (fabric side)	30"	49"	R3B1TF2B49 30-()()	\$1,674.	\$1,688.	\$1,720.	\$1,752.	\$1,780.	\$1,822.	\$1,861.
	36"	49"	R3B1TF2B49 36-()()	1,972.	1,986.	2,018.	2,050.	2,078.	2,120.	2,159.
	42"	49"	R3B1TF2B49 42-()()	2,127.	2,141.	2,173.	2,205.	2,233.	2,275.	2,314.
	48"	49"	R3B1TF2B49 48-()()	2,228.	2,242.	2,274.	2,306.	2,334.	2,376.	2,415.

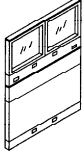

Order Code	Specification Information	Application Notes
Example: <b>R3B1TF2B4930-A4K</b>	<i>To order please specify pattern number including:</i>	<i>1. Top trim profile:</i>
<b>R3</b> Reff Generation 3		A = Flat
<b>B1</b> Beltway one side	1. Top trim profile	B = Square
<b>T</b> Tiled panel	2. Base height	C = Bullnose
<b>F2</b> Fabric one side, V2 other	3. Knockout option (K = with knockouts, N = without knockouts)	E = Extruded Aluminum
<b>B</b> Type B window	4. Tile divider (where optional) B = black steel divider or specify AA-anodized aluminum or painted option excluding silver from page 5 for extruded aluminum divider (upcharge applicable, optional "tiled" style products only)	2. Base height: 4 = 4" base height 6 = 6" base height (add \$47 per panel for this option)
<b>49</b> 49" high		The panels on this page will accept stacking modules to increase their height on 18" to 48"W panels only.
<b>30</b> 30" wide		6" Raceway option increases panel height by 2 3/4".
<b>A</b> Flat style top trim profile		Product on this page can be attached to posts 49", 64", and 79"H as well as panels 42", 49", 64" and 79"H. Panels on this page will not attach to panels made before April 1997 without an attachment kit from page 117.
<b>4</b> 4" base height		Remember to specify Beltway paint finish, glass type and windowframe finish from the paint selection at the front of the price list.
<b>K</b> Include knockouts in base	5. Fabric side, finish (specify selection per insert; bottom up.)	79"H hookstrip reveal strips are ordered separately from page 117 at no charge.
<b>B</b> Tile divider, black reveal	6. Conventional veneer side, finish (specify one V2 finish for side)	Applicable finishes are listed on page 5 and 6.
<b>W281</b> Fabric selection - side 1A	7. Top trim finish i) Top trim profile A,B or C options: V1, V2, V3, P1, P2, P3 finishes ii) Top trim profile E options: AA-anodized aluminum or P1, P2, P3 finish listed on page 5 excluding silver	
<b>W281</b> Fabric selection - side 1B		
<b>V316</b> Maple surface - side 2 tiled	8. Base finish	
<b>V316</b> Maple (top trim finish)	9. Beltway finish	
<b>111</b> Jet Black (base finish)	10. Window frame finish	
<b>111</b> Jet Black (beltway finish)	11. Glass option Temp = Clear temp <i>Architectural options:</i> GL13 = Powder glass GL6 = Block matrix glass GL8 = Wafer glass	
<b>111</b> Jet Black (window frame finish)		
<b>TEMP</b> Glass option		

Beltway one side, window panel 49" H  
*monolithic with glass at top,  
 fabric one side, conventional veneer other side*

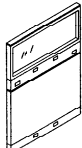
description	w	h	pattern no.	grade						
				10	15	20	30	35	40	45
Monolithic, fabric one side, Type A window on top, Beltway one side (fabric side) 	18"	49"	<b>R3B1PF2A49 18-()</b> ( )	\$1,178.	\$1,187.	\$1,208.	\$1,250.	\$1,276.	\$1,315.	\$1,341.
	20"	49"	<b>R3B1PF2A49 20-()</b> ( )	1,178.	1,187.	1,208.	1,250.	1,276.	1,315.	1,341.
	24"	49"	<b>R3B1PF2A49 24-()</b> ( )	1,236.	1,245.	1,266.	1,308.	1,334.	1,373.	1,399.
	30"	49"	<b>R3B1PF2A49 30-()</b> ( )	1,350.	1,359.	1,380.	1,422.	1,448.	1,487.	1,513.
	36"	49"	<b>R3B1PF2A49 36-()</b> ( )	1,628.	1,637.	1,658.	1,700.	1,726.	1,765.	1,791.
	42"	49"	<b>R3B1PF2A49 42-()</b> ( )	1,789.	1,798.	1,819.	1,861.	1,887.	1,926.	1,952.
	48"	49"	<b>R3B1PF2A49 48-()</b> ( )	1,897.	1,906.	1,927.	1,969.	1,995.	2,034.	2,060.

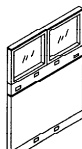
Monolithic, fabric one side, Type B window on top, Beltway one side (fabric side) 	30"	49"	<b>R3B1PF2B49 30-()</b> ( )	1,462.	1,471.	1,492.	1,534.	1,560.	1,599.	1,625.
	36"	49"	<b>R3B1PF2B49 36-()</b> ( )	1,745.	1,754.	1,775.	1,817.	1,844.	1,882.	1,908.
	42"	49"	<b>R3B1PF2B49 42-()</b> ( )	1,906.	1,915.	1,936.	1,978.	2,004.	2,043.	2,069.
	48"	49"	<b>R3B1PF2B49 48-()</b> ( )	2,024.	2,033.	2,054.	2,096.	2,122.	2,161.	2,187.

Order Code	Specification Information	Application Notes
Example: <b>R3B1TF2A4918-A4K</b>	<i>To order please specify pattern number including:</i>	<i>1. Top trim profile:</i>
<b>R3</b> Reff Generation 3		A = Flat
<b>B1</b> Beltway one side	1. Top trim profile	B = Square
<b>T</b> Tiled panel	2. Base height	C = Bullnose
<b>F2</b> Fabric one side, V2 other	3. Knockout option (K = with knockouts, N = without knockouts)	E = Extruded Aluminum
<b>A</b> Type A window	4. Tile divider (where optional) B = black steel divider or specify AA-anodized aluminum or painted option excluding silver from page 5 for extruded aluminum divider (upcharge applicable, optional "tiled" style products only)	2. Base height: 4 = 4" base height 6 = 6" base height (add \$47 per panel for this option)
<b>49</b> 49" high		The panels on this page will accept stacking modules to increase their height on 18" to 48"W panels only.
<b>18</b> 18" wide		6" Raceway option increases panel height by 2 3/4".
<b>A</b> Flat style top trim profile		
<b>4</b> 4" base height		
<b>K</b> Include knockouts in base	5. Fabric side, finish (specify selection per insert; bottom up.)	Product on this page can be attached to posts 49", 64", and 79"H as well as panels 42", 49", 64" and 79"H. Panels on this page will not attach to panels made before April 1997 without an attachment kit from page 117.
<b>B</b> Tile divider, black reveal	6. Conventional veneer side, finish (specify one V2 finish for side)	Remember to specify Beltway paint finish, glass type and window frame finish from the paint selection at the front of the price list.
<b>W281</b> Fabric selection - side 1	7. Top trim finish	
<b>V316</b> Maple surface - side 2	i) Top trim profile A,B or C options: V1, V2, V3, P1, P2, P3 finishes	
<b>V316</b> Maple (top trim finish)	ii) Top trim profile E options: AA-anodized aluminum or P1, P2, P3 finish listed on page 5 excluding silver	
<b>111</b> Jet Black (base finish)	8. Base finish	
<b>111</b> Jet Black (beltway finish)	9. Beltway finish	79"H hookstrip reveal strips are ordered separately from page 117 at no charge.
<b>111</b> Jet Black (window frame finish)	10. Window frame finish	Applicable finishes are listed on page 5 and 6.
<b>TEMP</b> Glass option	11. Glass option Temp = Clear temp Architectural options: GL13 = Powder glass GL6 = Block matrix glass GL8 = Wafer glass	

Add upcharge for architectural glass: (as applicable by widths)

Width	Add
18"	\$86
20"	\$86
24"	\$101
30"	\$121
36"	\$145
42"	\$173
48"	\$198

Frame finish:  
 Add to all products on this page: upcharge of \$35 per panel for P2 paint class options or \$63 per panel for P3 paint class options.

Add upcharge for extruded aluminum reveal/tile divider: (as applicable by width)  
 Optional non fabric tiled side only, fabric side always black

Width	Add
18"	\$14
20"	\$14
24"	\$15
30"	\$15
36"	\$16
42"	\$16
48"	\$21

# Beltway one side, window panel 49" H tiled with glass at top, fabric one side, exotic veneer other side

description	w	h	pattern no.	grade						
				10	15	20	30	35	40	45
Tiled, fabric one side, Beltway fabric side Type A window on top, Regular acoustics 	18"	49"	<b>R3B1TF3A49 18-( )</b>	\$1,882.	\$1,896.	\$1,928.	\$1,960.	\$1,988.	\$2,030.	\$2,069.
	20"	49"	<b>R3B1TF3A49 20-( )</b>	1,882.	1,896.	1,928.	1,960.	1,988.	2,030.	2,069.
	24"	49"	<b>R3B1TF3A49 24-( )</b>	1,939.	1,953.	1,985.	2,017.	2,045.	2,087.	2,126.
	30"	49"	<b>R3B1TF3A49 30-( )</b>	2,052.	2,066.	2,098.	2,130.	2,158.	2,200.	2,239.
	36"	49"	<b>R3B1TF3A49 36-( )</b>	2,439.	2,453.	2,485.	2,517.	2,545.	2,587.	2,626.
	42"	49"	<b>R3B1TF3A49 42-( )</b>	2,639.	2,653.	2,685.	2,717.	2,745.	2,787.	2,826.
	48"	49"	<b>R3B1TF3A49 48-( )</b>	2,754.	2,768.	2,800.	2,832.	2,860.	2,902.	2,941.

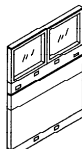
Tiled, fabric one side, Beltway fabric side Type B window on top, Regular acoustics 	30"	49"	<b>R3B1TF3B49 30-( )</b>	2,164.	2,178.	2,210.	2,242.	2,270.	2,312.	2,351.
	36"	49"	<b>R3B1TF3B49 36-( )</b>	2,556.	2,570.	2,602.	2,634.	2,662.	2,704.	2,743.
	42"	49"	<b>R3B1TF3B49 42-( )</b>	2,756.	2,770.	2,802.	2,834.	2,862.	2,904.	2,943.
	48"	49"	<b>R3B1TF3B49 48-( )</b>	2,881.	2,895.	2,927.	2,959.	2,987.	3,029.	3,068.

Order Code	Specification Information	Application Notes
Example: <b>R3B1TF3A4918-A4K</b>	<i>To order please specify pattern number including:</i>	<i>1. Top trim profile:</i>
<b>R3</b> Reff Generation 3		A = Flat
<b>B1</b> Beltway one side	1. Top trim profile	B = Square
<b>T</b> Tiled panel	2. Base height	C = Bullnose
<b>F3</b> Fabric one side, V3 other	3. Knockout option (K = with knockouts, N = without knockouts)	E = Extruded Aluminum
<b>A</b> Type A window	4. Tile divider (where optional) B = black steel divider or specify AA-anodized aluminum or painted option excluding silver from page 5 for extruded aluminum divider (upcharge applicable, optional "tiled" style products only)	2. Base height: 4 = 4" base height 6 = 6" base height (add \$47 per panel for this option)
<b>49</b> 49" high	5. Fabric side, finish (specify selection per insert; bottom up.)	The panels on this page will accept stacking modules to increase their height on 18" to 48"W panels only.
<b>18</b> 18" wide	6. Exotic veneer side, finish (specify one V3 finish for side)	6" Raceway option increases panel height by 2 3/4".
<b>A</b> Flat style top trim profile	7. Top trim finish i) Top trim profile A,B or C options: V1, V2, V3, P1, P2, P3 finishes ii) Top trim profile E options: AA-anodized aluminum or P1, P2, P3 finish listed on page 5 excluding silver	Product on this page can be attached to posts 49", 64", and 79"H as well as panels 42", 49", 64" and 79"H. Panels on this page will not attach to panels made before April 1997 without an attachment kit from page 117.
<b>4</b> 4" base height	8. Base finish	Remember to specify Beltway paint finish, glass type and windowframe finish from the paint selection at the front of the price list.
<b>K</b> Include knockouts in base	9. Beltway finish	79"H hookstrip reveal strips are ordered separately from page 117 at no charge.
<b>B</b> Tile divider, black reveal	10. Window frame finish	Applicable finishes are listed on page 5 and 6.
<b>W281</b> Fabric selection - side 1A	11. Glass option Temp = Clear temp <i>Architectural options:</i> GL13 = Powder glass GL6 = Block matrix glass GL8 = Wafer glass	
<b>W281</b> Fabric selection - side 1B		
<b>V512</b> Figured Anigre surface - side 2 tiled		
<b>V512</b> Figured Anigre (top trim finish)		
<b>111</b> Jet Black (base finish)		
<b>111</b> Jet Black (beltway finish)		
<b>111</b> Jet Black (window frame finish)		
<b>TEMP</b> Glass option		



# Beltway one side, window panel 49" H

*monolithic with glass at top, fabric one side, exotic veneer other side*

description	w	h	pattern no.	grade						
				10	15	20	30	35	40	45
Monolithic, fabric one side, Beltway fabric side Type A window on top, Regular acoustics	18"	49"	<b>R3B1PF3A49 18-( )</b> ( )	\$1,546.	\$1,555.	\$1,576.	\$1,618.	\$1,644.	\$1,683.	\$1,709.
	20"	49"	<b>R3B1PF3A49 20-( )</b> ( )	1,546.	1,555.	1,576.	1,618.	1,644.	1,683.	1,709.
	24"	49"	<b>R3B1PF3A49 24-( )</b> ( )	1,621.	1,630.	1,651.	1,693.	1,719.	1,758.	1,784.
	30"	49"	<b>R3B1PF3A49 30-( )</b> ( )	1,764.	1,773.	1,793.	1,836.	1,862.	1,901.	1,927.
	36"	49"	<b>R3B1PF3A49 36-( )</b> ( )	2,131.	2,140.	2,161.	2,203.	2,229.	2,268.	2,294.
	42"	49"	<b>R3B1PF3A49 42-( )</b> ( )	2,338.	2,347.	2,368.	2,410.	2,436.	2,475.	2,501.
	48"	49"	<b>R3B1PF3A49 48-( )</b> ( )	2,477.	2,486.	2,507.	2,549.	2,575.	2,614.	2,640.

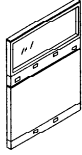

Monolithic, fabric one side, Beltway fabric side Type B window on top, Regular acoustics	30"	49"	<b>R3B1PF3B49 30-( )</b> ( )	1,876.	1,885.	1,906.	1,948.	1,974.	2,013.	2,039.
	36"	49"	<b>R3B1PF3B49 36-( )</b> ( )	2,248.	2,257.	2,278.	2,320.	2,346.	2,385.	2,411.
	42"	49"	<b>R3B1PF3B49 42-( )</b> ( )	2,455.	2,464.	2,485.	2,527.	2,553.	2,592.	2,618.
	48"	49"	<b>R3B1PF3B49 48-( )</b> ( )	2,604.	2,613.	2,634.	2,676.	2,702.	2,741.	2,767.

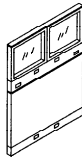

Order Code	Specification Information	Application Notes
Example: <b>R3B1PF3A4918-A4K</b>	<i>To order please specify pattern number including:</i>	<i>1. Top trim profile:</i>
<b>R3</b> Reff Generation 3		A = Flat
<b>B1</b> Beltway one side	1. Top trim profile	B = Square
<b>P</b> Monolithic panel	2. Base height	C = Bullnose
<b>F3</b> Fabric one side, V3 other	3. Knockout option (K = with knockouts, N = without knockouts)	E = Extruded Aluminum
<b>A</b> Type A window	4. Tile divider (where optional) B = black steel divider or specify AA-anodized aluminum or painted option excluding silver from page 5 for extruded aluminum divider (upcharge applicable, optional "tiled" style products only)	2. Base height: 4 = 4" base height 6 = 6" base height (add \$47 per panel for this option)
<b>49</b> 49" high	5. Fabric side, finish (specify selection per insert; bottom up.)	The panels on this page will accept stacking modules to increase their height on 18" to 48"W panels only.
<b>18</b> 18" wide	6. Exotic veneer side, finish (specify one V3 finish for side)	6" Raceway option increases panel height by 2 3/4".
<b>A</b> Flat style top trim profile	7. Top trim finish i) Top trim profile A,B or C options: V1, V2, V3, P1, P2, P3 finishes ii) Top trim profile E options: AA-anodized aluminum or P1, P2, P3 finish listed on page 5 excluding silver	Product on this page can be attached to posts 49", 64", and 79"H as well as panels 42", 49", 64" and 79"H. Panels on this page will not attach to panels made before April 1997 without an attachment kit from page 117.
<b>4</b> 4" base height	8. Base finish	Remember to specify Beltway paint finish, glass type and windowframe finish from the paint selection at the front of the price list.
<b>K</b> Include knockouts in base	9. Beltway finish	79"H hookstrip reveal strips are ordered separately from page 117 at no charge.
<b>B</b> Tile divider, black reveal	10. Window frame finish	Applicable finishes are listed on page 5 and 6.
<b>W281</b> Fabric selection - side 1	11. Glass option Temp = Clear temp <i>Architectural options:</i> GL13 = Powder glass GL6 = Block matrix glass GL8 = Wafer glass	
<b>V512</b> Figured Anigre surface - side 2		
<b>V512</b> Figured Anigre (top trim finish)		
<b>111</b> Jet Black (base finish)		
<b>111</b> Jet Black (beltway finish)		
<b>111</b> Jet Black (window frame finish)		
<b>TEMP</b> Glass option		

# Beltway two sides, window panel 49" H tiled with glass at top

description	w	h	pattern no.	grade						
				10	15	20	30	35	40	45
Tiled, fabric both sides, Regular acoustics, Type A window on top, Beltway two sides	18"	49"	<b>R3B2TFFA49 18-</b> ( ) ( )	\$1,261.	\$1,289.	\$1,343.	\$1,413.	\$1,469.	\$1,553.	\$1,605.
	20"	49"	<b>R3B2TFFA49 20-</b> ( ) ( )	1,261.	1,289.	1,343.	1,413.	1,469.	1,553.	1,605.
	24"	49"	<b>R3B2TFFA49 24-</b> ( ) ( )	1,307.	1,335.	1,389.	1,459.	1,515.	1,599.	1,651.
	30"	49"	<b>R3B2TFFA49 30-</b> ( ) ( )	1,398.	1,426.	1,480.	1,550.	1,606.	1,690.	1,742.
	36"	49"	<b>R3B2TFFA49 36-</b> ( ) ( )	1,681.	1,701.	1,763.	1,833.	1,889.	1,973.	2,025.
	42"	49"	<b>R3B2TFFA49 42-</b> ( ) ( )	1,830.	1,858.	1,912.	1,982.	2,038.	2,122.	2,174.
	48"	49"	<b>R3B2TFFA49 48-</b> ( ) ( )	1,919.	1,947.	2,001.	2,071.	2,127.	2,211.	2,263.

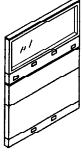

Tiled, fabric both sides, Regular acoustics, Type B window on top, Beltway two sides	30"	49"	<b>R3B2TFFB49 30-</b> ( ) ( )	1,506.	1,534.	1,588.	1,658.	1,714.	1,798.	1,850.
	36"	49"	<b>R3B2TFFB49 36-</b> ( ) ( )	1,798.	1,826.	1,880.	1,950.	2,006.	2,090.	2,142.
	42"	49"	<b>R3B2TFFB49 42-</b> ( ) ( )	1,946.	1,974.	2,028.	2,098.	2,154.	2,238.	2,290.
	48"	49"	<b>R3B2TFFB49 48-</b> ( ) ( )	2,044.	2,072.	2,126.	2,196.	2,252.	2,336.	2,388.

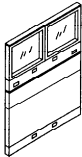

Order Code	Specification Information	Application Notes
Example: <b>R3B2TFFA4918-A4K</b>	<i>To order please specify pattern number including:</i>	<i>1. Top trim profile:</i>
<b>R3</b> Reff Generation 3	1. Top trim profile	A = Flat
<b>B2</b> Beltway two sides	2. Base height	B = Square
<b>T</b> Tiled panel	3. Knockout option	C = Bullnose
<b>FF</b> Fabric on both sides	(K = with knockouts, N = without knockouts)	E = Extruded Aluminum
<b>A</b> Type A window	4. Panel side 1 finish (specify selection per insert)	<i>2. Base height:</i>
<b>49</b> 49" high	5. Panel side 2 finish (specify selection per insert)	4 = 4" base height
<b>18</b> 18" wide	6. Top trim finish	6 = 6" base height (add \$47 per panel for this option)
<b>A</b> Flat style top trim profile	i) Top trim profile A,B or C options:	The panels on this page will accept stacking modules to increase their height on 18" to 48"W panels only.
<b>4</b> 4" base height	V1, V2, V3, P1, P2, P3 finishes	6" Raceway option increases panel height by 2 <sup>3</sup> / <sub>4</sub> ".
<b>K</b> Include knockouts in base	ii) Top trim profile E options:	Product on this page can be attached to posts 49", 64", and 79"H as well as panels 42", 49", 64" and 79"H. Panels on this page will not attach to panels made before April 1997 without an attachment kit from page 117.
<b>W281</b> Fabric selection - side 1A	AA-anodized aluminum or P1, P2, P3 finish listed on page 5 excluding silver	Remember to specify Beltway paint finish, glass type and windowframe finish from the paint selection at the front of the price list.
<b>W281</b> Fabric selection - side 1B	7. Base finish	79"H hookstrip reveal strips are ordered separately from page 117 at no charge.
<b>W281</b> Fabric selection - side 2A	8. Beltway finish	
<b>W281</b> Fabric selection - side 2B	9. Window frame finish	
<b>V316</b> Maple (top trim finish)	10. Glass option	
<b>111</b> Jet Black (base finish)	Temp = clear temp	
<b>111</b> Jet Black (beltway finish)	<i>Architectural options:</i>	
<b>111</b> Jet Black (window frame finish)	GL13 = Powder glass	
<b>TEMP</b> Glass option	GL6 = Block matrix glass	
	GL8 = Wafer glass	

Note: Extruded aluminum reveal/tile dividers are not optional for between fabric inserts.

Applicable finishes are listed on page 5 and 6.

Add upcharge for architectural glass: (as applicable by width)

Width	Add
18"	\$86
20"	\$86
24"	\$101
30"	\$121
36"	\$145
42"	\$173
48"	\$198

Frame finish:  
Add to all products on this page: upcharge of \$35 per panel for P2 paint class options or \$63 per panel for P3 paint class options.

# Beltway two sides, window panel 49" H monolithic with glass at top

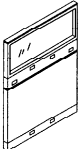
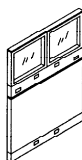
description	w	h	pattern no.	grade						
				10	15	20	30	35	40	45
Monolithic, fabric both sides, Type A window on top, Beltway two sides 	18"	49"	<b>R3B2PFFA49 18-()</b> ( )	\$1,138.	\$1,158.	\$1,198.	\$1,280.	\$1,334.	\$1,410.	\$1,458.
	20"	49"	<b>R3B2PFFA49 20-()</b> ( )	1,138.	1,158.	1,198.	1,280.	1,334.	1,410.	1,458.
	24"	49"	<b>R3B2PFFA49 24-()</b> ( )	1,180.	1,200.	1,240.	1,322.	1,376.	1,452.	1,500.
	30"	49"	<b>R3B2PFFA49 30-()</b> ( )	1,259.	1,279.	1,319.	1,401.	1,455.	1,531.	1,579.
	36"	49"	<b>R3B2PFFA49 36-()</b> ( )	1,497.	1,517.	1,557.	1,639.	1,693.	1,769.	1,817.
	42"	49"	<b>R3B2PFFA49 42-()</b> ( )	1,628.	1,648.	1,688.	1,770.	1,824.	1,900.	1,948.
	48"	49"	<b>R3B2PFFA49 48-()</b> ( )	1,705.	1,725.	1,765.	1,847.	1,901.	1,977.	2,025.
Monolithic, fabric both sides, Type B window on top, Beltway two sides 	30"	49"	<b>R3B2PFFB49 30-()</b> ( )	1,367.	1,387.	1,427.	1,509.	1,563.	1,639.	1,687.
	36"	49"	<b>R3B2PFFB49 36-()</b> ( )	1,614.	1,634.	1,674.	1,756.	1,810.	1,886.	1,934.
	42"	49"	<b>R3B2PFFB49 42-()</b> ( )	1,744.	1,764.	1,804.	1,886.	1,940.	2,016.	2,064.
	48"	49"	<b>R3B2PFFB49 48-()</b> ( )	1,830.	1,850.	1,890.	1,972.	2,026.	2,102.	2,150.

Order Code	Specification Information	Application Notes
Example: <b>R3B2PFFB4930-A4K</b>	<i>To order please specify pattern number including:</i>	<i>1. Top trim profile:</i>
<b>R3</b> Reff Generation 3	1. Top trim profile	A = Flat
<b>B2</b> Beltway two sides	2. Base height	B = Square
<b>P</b> Monolithic panel	3. Knockout option	C = Bullnose
<b>FF</b> Fabric on both sides	(K = with knockouts, N = without knockouts)	E = Extruded Aluminum
<b>B</b> Type B window	4. Panel side 1 finish (specify selection per insert)	<i>2. Base height:</i>
<b>49</b> 49" high	5. Panel side 2 finish (specify selection per insert)	4 = 4" base height
<b>30</b> 30" wide	6. Top trim finish	6 = 6" base height (add \$47 per panel for this option)
<b>A</b> Flat style top trim profile	i) Top trim profile A,B or C options:	The panels on this page will accept stacking modules to increase their height on 18" to 48"W panels only.
<b>4</b> 4" base height	V1, V2, V3, P1, P2, P3 finishes	6" Raceway option increases panel height by 2 3/4".
<b>K</b> Include knockouts in base	ii) Top trim profile E options: AA-anodized aluminum or P1, P2, P3 finish listed on page 5 excluding silver	Product on this page can be attached to posts 49", 64", and 79"H as well as panels 42", 49", 64" and 79"H. Panels on this page will not attach to panels made before April 1997 without an attachment kit from page 117.
<b>W281</b> Fabric selection - side 1	7. Base finish	Remember to specify Beltway paint finish, glass type and window frame finish from the paint selection at the front of the price list.
<b>W281</b> Fabric selection - side 2	8. Beltway finish	
<b>V316</b> Maple (top trim finish)	9. Window frame finish	
<b>111</b> Jet Black (base finish)	10. Glass option	
<b>111</b> Jet Black (beltway finish)	Temp = clear temp	
<b>111</b> Jet Black (window frame finish)	<i>Architectural options:</i>	
<b>TEMP</b> Glass option	GL13 = Powder glass	
	GL6 = Block matrix glass	
	GL8 = Wafer glass	

Note: Extruded aluminum reveal/tile dividers are not optional for between fabric inserts.

Applicable finishes are listed on page 5 and 6.

Add upcharge for architectural glass: (as applicable by width)

Width	Add
18"	\$86
20"	\$86
24"	\$101
30"	\$121
36"	\$145
42"	\$173
48"	\$198

Frame finish:  
Add to all products on this page: upcharge of \$35 per panel for P2 paint class options or \$63 per panel for P3 paint class options.

# Stacking modules *fabric*

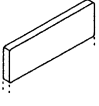
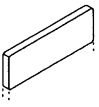
description	w	h	pattern no.	grade	15	20	30	35	40	45
				10						
Stacking modules *,** Fabric both sides	18"	8"	<b>R3SFF08 18</b>	\$204.	\$210.	\$228.	\$260.	\$272.	\$292.	\$306.
	20"	8"	<b>R3SFF08 20</b>	204.	210.	228.	260.	272.	292.	306.
	24"	8"	<b>R3SFF08 24</b>	214.	220.	238.	270.	282.	302.	316.
	30"	8"	<b>R3SFF08 30</b>	238.	244.	262.	294.	306.	326.	340.
	36"	8"	<b>R3SFF08 36</b>	260.	266.	284.	316.	328.	348.	362.
	42"	8"	<b>R3SFF08 42</b>	283.	289.	307.	339.	351.	371.	385.
	48"	8"	<b>R3SFF08 48</b>	304.	310.	328.	360.	372.	392.	406.
Stacking modules* Fabric both sides	18"	15"	<b>R3SFF15 18</b>	276.	290.	320.	352.	380.	422.	446.
	20"	15"	<b>R3SFF15 20</b>	276.	290.	320.	352.	380.	422.	446.
	24"	15"	<b>R3SFF15 24</b>	291.	305.	335.	367.	395.	437.	461.
	30"	15"	<b>R3SFF15 30</b>	320.	334.	364.	396.	424.	466.	490.
	36"	15"	<b>R3SFF15 36</b>	353.	367.	397.	429.	457.	499.	523.
	42"	15"	<b>R3SFF15 42</b>	381.	395.	425.	457.	485.	527.	551.
	48"	15"	<b>R3SFF15 48</b>	412.	426.	456.	488.	516.	558.	582.

## Order Code

Example: <b>R3SFF0818</b>	
<b>R3</b>	Reff Generation 3
<b>S</b>	Stacking module
<b>FF</b>	Fabric/fabric
<b>08</b>	8" high
<b>18</b>	18" wide
<b>W281</b>	Fabric selection - side 1
<b>W281</b>	Fabric selection - side 2

## Specification Information

To order please specify:

1. Pattern number including height and width
2. Panel side 1 finish fabric only
3. Panel side 2 finish fabric only

## Application Notes

\* Not for use on 79"H panels.

\* \* Suitable only for top of any panel. Cannot be stacked upon.

8"h module will not accept additional modules on top.

Use of 8" module on panel heights other than 34"h will require custom end trims and Hi-Lo parts.

Stacking modules on this page are high acoustic with a hard board septum and fiberglass.

# Stacking modules *window*

description	w	h	pattern no.	clear glass	arch glass	add for P2 finish	add for P3 finish	AA frame upcharge
Stacking window module* Single glass, type "A"	18"	15"	<b>RSWA15 18</b>	\$449.	\$539.	\$15.	\$28.	\$46.
	20"	15"	<b>RSWA15 20</b>	449.	539.	15.	28.	46.
	24"	15"	<b>RSWA15 24</b>	473.	575.	15.	28.	49.
	30"	15"	<b>RSWA15 30</b>	548.	641.	15.	28.	54.
	36"	15"	<b>RSWA15 36</b>	568.	722.	15.	28.	55.
	42"	15"	<b>RSWA15 42</b>	598.	774.	15.	28.	58.
	48"	15"	<b>RSWA15 48</b>	619.	824.	15.	28.	61.

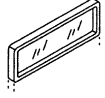

Stacking window module* Center mullion, type "B"	30"	15"	<b>RSWB15 30</b>	655.	784.	15.	28.	65.
	36"	15"	<b>RSWB15 36</b>	686.	837.	15.	28.	68.
	42"	15"	<b>RSWB15 42</b>	715.	892.	15.	28.	71.
	48"	15"	<b>RSWB15 48</b>	743.	946.	15.	28.	73.

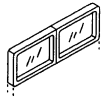

Stacking window module*	18"	30"	<b>RSWC30 18</b>	541.	627.	23.	36.	54.
	20"	30"	<b>RSWC30 20</b>	541.	627.	23.	36.	54.
	24"	30"	<b>RSWC30 24</b>	577.	683.	23.	36.	58.
	30"	30"	<b>RSWC30 30</b>	751.	879.	23.	36.	75.
	36"	30"	<b>RSWC30 36</b>	855.	1,011.	23.	36.	83.
	42"	30"	<b>RSWC30 42</b>	917.	1,096.	23.	36.	90.
	48"	30"	<b>RSWC30 48</b>	971.	1,179.	23.	36.	94.



18" - 24"

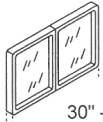

30" - 48"

Order Code	Specification Information	Application Notes
Example: <b>RSWA1518 111 TEMP</b>	<i>To order please specify:</i>	* Not for use on 79"H panels.
<b>R</b> Reff	1. Pattern number	Panel glass is mounted flush to one side of window module.
<b>SW</b> Stacking window module	2. Frame finish (Painted or Anodized aluminum finishes) <i>If P2 or P3 paint finish upcharge applicable</i> <i>If AA finish (anodized) upcharge applicable as noted in AA price column</i>	All window modules incorporate tempered glass (3/16" thick).
<b>A</b> Type A	3. Glass type	30"H window panels that are 30" or wider incorporate a center mullion.
<b>15</b> 15" high	Temp = Clear tempered glass	For window panels specify the finish for frames from paint selection on page 5.
<b>18</b> 18" wide	<i>Architectural options:</i> GL13 = Powder glass GL6 = Block matrix glass GL8 = Wafer glass	
<b>111</b> Jet Black, window frame finish		
<b>TEMP</b> Clear tempered glass option		

# Stacking modules

## Double Window

description	h	w	pattern no.	G1 clear glass	G2 architectural glass	L	V1	V2	V3	AA
Stacking window module* Single glass, type "A"	15"	60"	<b>RSWAD1560</b> ( ) ( )	\$702.	\$803.					
		72"	<b>RSWAD1572</b> ( ) ( )	782.	937.					
		84"	<b>RSWAD1584</b> ( ) ( )	791.	977.					
		96"	<b>RSWAD1596</b> ( ) ( )	805.	1,019.					
	22"	60"	<b>RSWAD2260</b> ( ) ( )	876.	1,071.					
		72"	<b>RSWAD2272</b> ( ) ( )	985.	1,219.					
		84"	<b>RSWAD2284</b> ( ) ( )	1,004.	1,277.					
		96"	<b>RSWAD2296</b> ( ) ( )	1,024.	1,337.					
Top trim for double wide stacking window modules	60"	<b>R3CRTT60</b> ( ) ( )				76.	155.	172.	222.	127.
	72"	<b>R3CRTT72</b> ( )				81.	166.	182.	234.	172.
	84"	<b>R3CRTT84</b> ( )				98.	187.	204.	259.	188.
	96"	<b>R3CRTT96</b> ( )				103.	197.	215.	273.	193.

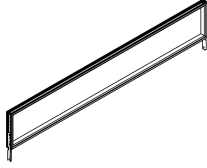

Order Code	Specification Information	Application Notes
<i>Example:</i> <b>RSWAD1560</b>	<i>To order please specify:</i>	Panel glass is mounted flush to one side of the window module.
<b>R</b> Reff	1. Pattern number	All window modules incorporate tempered glass 4mm thick.
<b>SW</b> Stacking window	2. Frame finish (Painted or Anodized aluminum finishes)	Stabilizing kit is included with the window and is required with all double wide window installation.
<b>A</b> Type A	<i>If P2 or P3 paint finish upcharge add \$25</i>	
<b>D</b> Double wide	<i>If AA finish (anodized) upcharge applicable as noted in AA price add \$45</i>	Full length top trim is optional and can be ordered separately.
<b>15</b> 15" high	3. Glass type	Not for use on 79" h panels.
<b>60</b> 60" wide	Temp = Clear tempered glass	Applicable finishes are listed on page 5
<b>111</b> Jet Black, windowframe finish	<i>Architectural options:</i>	
<b>TEMP</b> Clear tempered glass option	GL13 = Powder glass	
	GL6 = Block matrix glass	
	GL8 = Wafer glass	

# Stacking modules

*fabric one side/laminate, techwood, conventional or exotic veneer  
other side and laminate both sides*

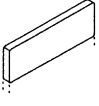
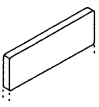
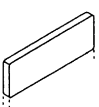
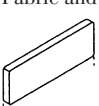
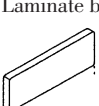
description	w	h	pattern no.	grade						Lam.
				10	15	20	30	35	40	
Stacking modules **, ** Fabric and laminate 	18"	8"	<b>R3SFL0818</b>	\$232.	\$237.	\$255.	\$287.	\$301.	\$321.	\$339.
	20"	8"	<b>R3SFL0820</b>	232.	237.	255.	287.	301.	321.	339.
	24"	8"	<b>R3SFL0824</b>	251.	256.	274.	306.	320.	340.	358.
	30"	8"	<b>R3SFL0830</b>	282.	287.	305.	337.	351.	371.	389.
	36"	8"	<b>R3SFL0836</b>	309.	314.	332.	364.	378.	398.	416.
	42"	8"	<b>R3SFL0842</b>	335.	340.	358.	390.	404.	424.	442.
	48"	8"	<b>R3SFL0848</b>	364.	369.	387.	419.	433.	453.	471.
Stacking modules **, ** Fabric and techwood 	18"	8"	<b>R3SF10818</b>	238.	243.	261.	293.	307.	327.	345.
	20"	8"	<b>R3SF10820</b>	238.	243.	261.	293.	307.	327.	345.
	24"	8"	<b>R3SF10824</b>	255.	260.	278.	310.	324.	344.	362.
	30"	8"	<b>R3SF10830</b>	286.	291.	308.	341.	355.	375.	393.
	36"	8"	<b>R3SF10836</b>	313.	318.	336.	368.	382.	402.	420.
	42"	8"	<b>R3SF10842</b>	343.	348.	366.	398.	412.	432.	450.
	48"	8"	<b>R3SF10848</b>	369.	374.	392.	424.	438.	458.	476.
Stacking modules **, ** Fabric and conventional veneer 	18"	8"	<b>R3SF20818</b>	241.	246.	264.	296.	310.	330.	348.
	20"	8"	<b>R3SF20820</b>	241.	246.	264.	296.	310.	330.	348.
	24"	8"	<b>R3SF20824</b>	261.	266.	284.	316.	330.	350.	368.
	30"	8"	<b>R3SF20830</b>	291.	296.	314.	346.	360.	380.	398.
	36"	8"	<b>R3SF20836</b>	320.	325.	343.	375.	389.	409.	427.
	42"	8"	<b>R3SF20842</b>	349.	354.	372.	404.	418.	438.	456.
	48"	8"	<b>R3SF20848</b>	374.	379.	397.	429.	443.	463.	481.
Stacking modules **, ** Fabric and exotic veneer 	18"	8"	<b>R3SF30818</b>	317.	322.	340.	372.	386.	406.	424.
	20"	8"	<b>R3SF30820</b>	317.	322.	340.	372.	386.	406.	424.
	24"	8"	<b>R3SF30824</b>	346.	351.	369.	401.	415.	435.	453.
	30"	8"	<b>R3SF30830</b>	384.	389.	407.	439.	453.	473.	491.
	36"	8"	<b>R3SF30836</b>	425.	430.	448.	480.	494.	514.	532.
	42"	8"	<b>R3SF30842</b>	464.	469.	487.	519.	533.	553.	571.
	48"	8"	<b>R3SF30848</b>	499.	504.	522.	554.	568.	588.	606.
Stacking modules **, ** Laminate both sides 	18"	8"	<b>R3SLL0818</b>							224.
	20"	8"	<b>R3SLL0820</b>							224.
	24"	8"	<b>R3SLL0824</b>							244.
	30"	8"	<b>R3SLL0830</b>							273.
	36"	8"	<b>R3SLL0836</b>							295.
	42"	8"	<b>R3SLL0842</b>							304.
	48"	8"	<b>R3SLL0848</b>							314.

**Order Code**

Example:	<b>R3SFL0818</b>
<b>R3</b>	Reff Generation 3
<b>S</b>	Stacking module
<b>FL</b>	Fabric/Laminate
<b>08</b>	8" high
<b>18</b>	18" wide
<b>W281</b>	Fabric selection - side 1
<b>114</b>	Folkstone Grey - side 2

**Specification Information**

*To order please specify:*

1. Pattern number
2. Panel side 1 finish(s)
3. Panel side 2 finish(s)

Product on this page will accept wood grain laminate where laminate is currently an option. Panel product is subject to a 10% upcharge on the base panel price. Refer to panel product upcharge table.

**Application Notes**

\* Not for use on 79"H panels.

\* \* Suitable only for top of any panel. Cannot be stacked upon and may require custom end trims and Hi-Lo parts.

Provide elevation drawings for conventional veneer panel stacking applications and/or floor to ceiling. Elevation drawings are not required for techwood.

8" module will not accept additional modules.

Stacking modules on this page are high acoustic with a hard board septum and fiberglass.

Applicable finishes are listed on page 5 and 6.

Frameless glass add-ups cannot be installed on these modules.

# Stacking modules

*fabric one side/laminate, techwood, conventional or exotic veneer  
other side and laminate both sides*

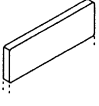
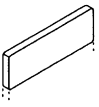
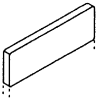
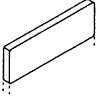
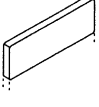
description	w	h	pattern no.	grade						Lam.
				10	15	20	30	35	40	
Stacking modules* Fabric and laminate 	18"	15"	<b>R3SFL1518</b>	\$332.	\$347.	\$376.	\$410.	\$441.	\$484.	\$508.
	20"	15"	<b>R3SFL1520</b>	332.	347.	376.	410.	441.	484.	508.
	24"	15"	<b>R3SFL1524</b>	346.	361.	390.	424.	455.	498.	522.
	30"	15"	<b>R3SFL1530</b>	379.	394.	423.	457.	488.	531.	555.
	36"	15"	<b>R3SFL1536</b>	411.	426.	455.	489.	520.	563.	587.
	42"	15"	<b>R3SFL1542</b>	443.	458.	487.	521.	552.	595.	619.
	48"	15"	<b>R3SFL1548</b>	474.	489.	518.	552.	583.	626.	650.
Stacking modules* Fabric and techwood 	18"	15"	<b>R3SF11518</b>	340.	355.	384.	418.	449.	492.	516.
	20"	15"	<b>R3SF11520</b>	340.	355.	384.	418.	449.	492.	516.
	24"	15"	<b>R3SF11524</b>	354.	369.	398.	432.	463.	506.	530.
	30"	15"	<b>R3SF11530</b>	384.	399.	428.	462.	493.	536.	560.
	36"	15"	<b>R3SF11536</b>	418.	433.	462.	496.	526.	570.	594.
	42"	15"	<b>R3SF11542</b>	450.	465.	494.	528.	559.	602.	626.
	48"	15"	<b>R3SF11548</b>	481.	496.	525.	559.	590.	633.	657.
Stacking modules* Fabric and conventional veneer 	18"	15"	<b>R3SF21518</b>	344.	359.	388.	422.	453.	496.	520.
	20"	15"	<b>R3SF21520</b>	344.	359.	388.	422.	453.	496.	520.
	24"	15"	<b>R3SF21524</b>	360.	375.	404.	438.	469.	512.	536.
	30"	15"	<b>R3SF21530</b>	394.	409.	438.	472.	503.	546.	570.
	36"	15"	<b>R3SF21536</b>	427.	442.	471.	505.	536.	579.	603.
	42"	15"	<b>R3SF21542</b>	460.	475.	504.	538.	569.	612.	636.
	48"	15"	<b>R3SF21548</b>	488.	503.	532.	566.	597.	640.	664.
Stacking modules* Fabric and exotic veneer 	18"	15"	<b>R3SF315 18</b>	453.	468.	497.	531.	562.	605.	629.
	20"	15"	<b>R3SF315 20</b>	453.	468.	497.	531.	562.	605.	629.
	24"	15"	<b>R3SF315 24</b>	475.	490.	519.	553.	584.	627.	651.
	30"	15"	<b>R3SF315 30</b>	520.	535.	564.	598.	629.	672.	696.
	36"	15"	<b>R3SF315 36</b>	566.	581.	610.	644.	675.	718.	742.
	42"	15"	<b>R3SF315 42</b>	609.	624.	653.	687.	718.	761.	785.
	48"	15"	<b>R3SF315 48</b>	650.	665.	694.	728.	759.	802.	826.
Stacking modules* Laminate both sides 	18"	15	<b>R3SLL1518</b>							317.
	20"	15	<b>R3SLL1520</b>							317.
	24"	15	<b>R3SLL1524</b>							345.
	30"	15	<b>R3SLL1530</b>							387.
	36"	15	<b>R3SLL1536</b>							418.
	42"	15	<b>R3SLL1542</b>							430.
	48"	15	<b>R3SLL1548</b>							432.

Order Code	Specification Information	Application Notes
Example: <b>R3SFL0818</b>	<i>To order please specify:</i>	* Not for use on 79"H panels.
<b>R3</b> Reff Generation 3	1. Pattern number	* * Suitable only for top of any panel. Cannot be stacked upon and may require custom end trims and Hi-Lo parts.
<b>S</b> Stacking module	2. Panel side 1 finish(s)	Provide elevation drawings for conventional veneer panel stacking applications and/or floor to ceiling. Elevation drawings are not required for techwood.
<b>FL</b> Fabric/Laminate	3. Panel side 2 finish(s)	8" module will not accept additional modules.
<b>08</b> 8" high	Product on this page will accept wood grain laminate where laminate is currently an option.	Stacking modules on this page are high acoustic with a hard board septum and fiberglass.
<b>18</b> 18" wide	Panel product is subject to a 10% upcharge on the base panel price. Refer to panel product upcharge table.	Applicable finishes are listed on page 5 and 6.
<b>W281</b> Fabric selection - side 1		Frameless glass add-ups cannot be installed on these modules.
<b>114</b> Folkstone Grey - side 2		



# Panel connection posts

## Generation 3

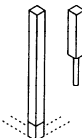
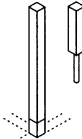
description	h		pattern no.	Reg. post list (A/B/C profile)	Beltway post list (B)
 L-Post	8"	stacking module post	<b>R3L08TT</b>	\$63.	n/a
	15"	stacking module post	<b>R3L15TT</b>	123.	n/a
	34"		<b>R3L34(F/T)(F/T)-( ) ( ) ( )</b>	157.	n/a
	42"		<b>R3L42(B)(F/T)(F/T)-( ) ( ) ( )</b>	237.	273.
	49"		<b>R3L49(B)(F/T)(F/T)-( ) ( ) ( )</b>	263.	302.
	64"		<b>R3L64(B)(F/T)(F/T)-( ) ( ) ( )</b>	291.	333.
	79"		<b>R3L79(B)(F/T)(F/T)-( ) ( ) ( )</b>	325.	373.
 T-Post	8"	stacking module post	<b>R3T08T</b>	79.	n/a
	15"	stacking module post	<b>R3T15T</b>	146.	n/a
	34"		<b>R3T34(F/T)-( ) ( ) ( )</b>	191.	n/a
	42"		<b>R3T42(B)(F/T)-( ) ( ) ( )</b>	209.	239.
	49"		<b>R3T49(B)(F/T)-( ) ( ) ( )</b>	237.	273.
	64"		<b>R3T64(B)(F/T)-( ) ( ) ( )</b>	263.	302.
	79"		<b>R3T79(B)(F/T)-( ) ( ) ( )</b>	292.	336.

### Order Code

Example:	<b>R3L64(B)TT-A16NB</b>
<b>R3</b>	Reff Generation 3
<b>L64</b>	90° post; 64" h connector
<b>(B)</b>	with Beltway channel
<b>(T)(T)</b>	Tiled appearance 2 sides
<b>(A)</b>	Flat top profile
<b>(1)</b>	Regular L top cap
<b>(6)</b>	6" base height
<b>(N)</b>	No base infeed raceway knock-out
<b>(B)</b>	Tile divider, black reveal
<b>W808</b>	Face side 1, fabric selection
<b>W808</b>	Face side 2, fabric selection
<b>V316</b>	Top cap finish, Maple
<b>111</b>	Base finish, Jet black

\*R3R2SLV is required when adding a Reff Generation 2 stacking module post to a Generation 3 base post and required when adding a Generation 3 stacking module post to a Generation 2 base post. Installation instructions will ship with the sleeve.

**Note: New top caps are required in these two applications. Refer to page 419.**

### Specification Information

To order please specify pattern number including:

1. Post face option
2. Top cap profile
3. Top cap configuration
4. If L post, cover configuration
  - 1 = one piece (same finish both sides)
  - 2 = two piece (same or different finish per side)
5. Base height option
6. Base infeed knock-out (optional)
7. Tile divider option/finish, if face type T
8. Finish, face covers (fabric, V1, V2, V3 or painted to match laminate)
9. Top cap finish
  - i) Top trim profile A,B or C options: V1, V2, V3, P1, P2, P3 finishes
  - ii) Top trim profile E options: AA-anodized aluminum or P1, P2, P3 finish listed on page 5 excluding silver
10. Base finish

1. Face type:  
(F) = Full height (monolithic look)  
(T) = Tiled

2. Top profile:  
A = Flat  
B = Square  
C = Bullnose  
E = Extruded Aluminum  
(Add \$25 list for this option)

3. Top cap configuration:  
1 = Regular L or cap finish 2 adjacent sides (applicable for L, T or X posts only)  
2 = Regular T or cap finish 1 side (applicable for T or X posts only)  
3 = Regular X cap unfinished all 4 sides (applicable for X posts only)  
4 = Cap finished 3 sides/high-low (applicable for L, T, X or straight posts)  
5 = Cap finished 2 opposite sides/high-low (applicable for X or straight posts only)

5. Base height:  
4 = 4" base height  
6 = 6" base height (add \$47 list for this option)

6. Electrical infeed post:  
L = Base infeed left face  
M = Base infeed middle face  
R = Base infeed right face  
N = None

7. Tile divider, optional if face type "tiled" and face finish "non-fabric"  
B = Black steel reveal or Specify AA for anodized aluminum look or painted option from page 5 excluding silver.

Specify AA-anodized aluminum or painted options excluding silver from page 5.

Posts will accept Beltway, Monolithic, Tiled and stacking modules. The connection of 34"H panels to Beltway posts requires the use of the attachment kit on page 117. All posts on this page will accept the 15" stacking modular Post but only to achieve a finished height of 49", 64", or 79". The 8"H Post module is primarily for transitioning a 34"H post into a 42"H post and to meet transaction height 8"H post or panel module cannot have a module mounted

above itself), however, the 8"H post module can be used on the very top of any post to achieve non-standard heights. Custom Hi-Lo parts will then be required. The use of a 34"H post will not allow for the passing of beltway electrical.

Specify the mouse hole location for end power electric. Reference Planning Guide for details. Top cap orientation must be specified to achieve the right top cap for the panel heights involved. If any panel in the post connection is lower than post height, than one must determine which cap is appropriate (consult Planning Guide, pages 58-60).

Beltway posts are only required when electrical runs through the post in a 90° or straight. Always specify the post height to match the tallest panel.

Applicable finishes are listed on page 5 and 6.

# Panel connection posts

## Generation 3

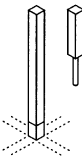
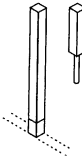
description	h		pattern no.	Reg. post list (A/B/C profile)	Beltway post list (B)
 X-Post	8"	stacking module post	<b>R3X08</b>	\$70.	n/a
	15"	stacking module post	<b>R3X15</b>	134.	n/a
	34"		<b>R3X34-( ) ( )</b>	178.	n/a
	42"		<b>R3X42(B)-( ) ( )</b>	193.	223.
	49"		<b>R3X49(B)-( ) ( )</b>	209.	239.
	64"		<b>R3X64(B)-( ) ( )</b>	237.	273.
	79"		<b>R3X79(B)-( ) ( )</b>	270.	307.
 Straight post	8"	stacking module post	<b>R3S08TT</b>	63.	n/a
	15"	stacking module post	<b>R3S15TT</b>	123.	n/a
	34"		<b>R3S34(F/T)(F/T)-( ) ( ) ( )</b>	157.	n/a
	42"		<b>R3S42(B)(F/T)(F/T)-( ) ( ) ( )</b>	237.	273.
	49"		<b>R3S49(B)(F/T)(F/T)-( ) ( ) ( )</b>	263.	302.
	64"		<b>R3S64(B)(F/T)(F/T)-( ) ( ) ( )</b>	291.	333.
	79"		<b>R3S79(B)(F/T)(F/T)-( ) ( ) ( )</b>	325.	373.

### Order Code

Example:	<b>R3L64(B)TT-A16NB</b>
<b>R3</b>	Reff Generation 3
<b>L64</b>	90° post; 64" h connector
<b>(B)</b>	with Beltway channel
<b>(T)(T)</b>	Tiled appearance 2 sides
<b>(A)</b>	Flat top profile
<b>(1)</b>	Regular L top cap
<b>(6)</b>	6" base height
<b>(N)</b>	No base infeed raceway knock-out
<b>(B)</b>	Tile divider, black reveal
<b>W808</b>	Face side 1, fabric selection
<b>W808</b>	Face side 2, fabric selection
<b>V316</b>	Top cap finish, Maple
<b>111</b>	Base finish, Jet black

\*R3R2SLV is required when adding a Reff Generation 2 stacking module post to a Generation 3 base post and required when adding a Generation 3 stacking module post to a Generation 2 base post. Installation instructions will ship with the sleeve.

**Note: New top caps are required in these two applications. Refer to page 419.**

### Specification Information

To order please specify pattern number including:

1. Post face option
2. Top cap profile
3. Top cap configuration
4. If L post, cover configuration
  - 1 = one piece (same finish both sides)
  - 2 = two piece (same or different finish per side)
5. Base height option
6. Base infeed knock-out (optional)
7. Tile divider option/finish, if face type T
8. Finish, face covers (fabric, V1, V2, V3 or painted to match laminate)
9. Top cap finish
  - i) Top trim profile A,B or C options: V1, V2, V3, P1, P2, P3 finishes
  - ii) Top trim profile E options: AA-anodized aluminum or P1, P2, P3 finish listed on page 5 excluding silver
10. Base finish

1. Face type:  
(F) = Full height (monolithic look)  
(T) = Tiled

2. Top profile:  
A = Flat  
B = Square  
C = Bullnose  
E = Extruded Aluminum  
(Add \$25 list for this option)

3. Top cap configuration:

- 1 = Regular L or cap finish 2 adjacent sides (applicable for L, T or X posts only)
- 2 = Regular T or cap finish 1 side (applicable for T or X posts only)
- 3 = Regular X cap unfinished all 4 sides (applicable for X posts only)
- 4 = Cap finished 3 sides/high-low (applicable for L, T, X or straight posts)
- 5 = Cap finished 2 opposite sides/high-low (applicable for X or straight posts only)

5. Base height:

- 4 = 4" base height
- 6 = 6" base height (add \$47 list for this option)

6. Electrical infeed post:

- L = Base infeed left face
- M = Base infeed middle face
- R = Base infeed right face
- N = None

7. Tile divider, optional if face type

- "tiled" and face finish "non-fabric"
- B = Black steel reveal or Specify AA for anodized aluminum look or painted option from page 5 excluding silver.

Specify AA-anodized aluminum or painted options excluding silver from page 5.

Posts will accept Beltway, Monolithic, Tiled and stacking modules. The connection of 34"H panels to Beltway posts requires the use of the attachment kit on page 117. All posts on this page will accept the 15" stacking modular Post but only to achieve a finished height of 49", 64", or 79". The 8"H Post module is primarily for transitioning a 34"H post into a 42"H post and to meet transaction height 8"H post or panel module cannot have a module mounted

above itself), however, the 8"H post module can be used on the very top of any post to achieve non-standard heights. Custom Hi-Lo parts will then be required. The use of a 34"H post will not allow for the passing of beltway electrical.

Specify the mouse hole location for end power electric. Reference Planning Guide for details. Top cap orientation must be specified to achieve the right top cap for the panel heights involved. If any panel in the post connection is lower than post height, than one must determine which cap is appropriate (consult Planning Guide, pages 58-60).

Beltway posts are only required when electrical runs through the post in a 90° or straight. Always specify the post height to match the tallest panel.

Applicable finishes are listed on page 5 and 6.

# Panel connection posts

## Generation 3

description	h	pattern no.	Reg. post list (A/B/C profile)	Beltway post list (B)
*R3/R2 stacking post sleeve		adapter kit for stacking posts only	<b>R3R2SLV</b>	n/c



### Order Code

Example:	<b>R3L64(B)TT-A16NB</b>
<b>R3</b>	Reff Generation 3
<b>L64</b>	90° post; 64" h connector
<b>(B)</b>	with Beltway channel
<b>(T)(T)</b>	Tiled appearance 2 sides
<b>(A)</b>	Flat top profile
<b>(1)</b>	Regular L top cap
<b>(6)</b>	6" base height
<b>(N)</b>	No base infeed raceway knock-out
<b>(B)</b>	Tile divider, black reveal
<b>W808</b>	Face side 1, fabric selection
<b>W808</b>	Face side 2, fabric selection
<b>V316</b>	Top cap finish, Maple
<b>111</b>	Base finish, Jet black

\*R3R2SLV is required when adding a Reff Generation 2 stacking module post to a Generation 3 base post and required when adding a Generation 3 stacking module post to a Generation 2 base post. Installation instructions will ship with the sleeve.

**Note: New top caps are required in these two applications. Refer to page 419.**

### Specification Information

To order please specify pattern number including:

1. Post face option
2. Top cap profile
3. Top cap configuration
4. If L post, cover configuration
  - 1 = one piece (same finish both sides)
  - 2 = two piece (same or different finish per side)
5. Base height option
6. Base infeed knock-out (optional)
7. Tile divider option/finish, if face type T
8. Finish, face covers (fabric, V1, V2, V3 or painted to match laminate)
9. Top cap finish
  - i) Top trim profile A,B or C options: V1, V2, V3, P1, P2, P3 finishes
  - ii) Top trim profile E options: AA-anodized aluminum or P1, P2, P3 finish listed on page 5 excluding silver
10. Base finish

1. Face type:  
(F) = Full height (monolithic look)  
(T) = Tiled

2. Top profile:  
A = Flat  
B = Square  
C = Bullnose  
E = Extruded Aluminum  
(Add \$25 list for this option)

3. Top cap configuration:  
1 = Regular L or cap finish 2 adjacent sides (applicable for L, T or X posts only)  
2 = Regular T or cap finish 1 side (applicable for T or X posts only)  
3 = Regular X cap unfinished all 4 sides (applicable for X posts only)  
4 = Cap finished 3 sides/high-low (applicable for L, T, X or straight posts)  
5 = Cap finished 2 opposite sides/high-low (applicable for X or straight posts only)

5. Base height:  
4 = 4" base height  
6 = 6" base height (add \$47 list for this option)

6. Electrical infeed post:  
L = Base infeed left face  
M = Base infeed middle face  
R = Base infeed right face  
N = None

7. Tile divider, optional if face type "tiled" and face finish "non-fabric"  
B = Black steel reveal or Specify AA for anodized aluminum look or painted option from page 5 excluding silver.

Specify AA-anodized aluminum or painted options excluding silver from page 5.

Posts will accept Beltway, Monolithic, Tiled and stacking modules. The connection of 34"H panels to Beltway posts requires the use of the attachment kit on page 117. All posts on this page will accept the 15" stacking modular Post but only to achieve a finished height of 49", 64", or 79". The 8"H Post module is primarily for transitioning a 34"H post into a 42"H post and to meet transaction height 8"H post or panel module cannot have a module mounted

above itself), however, the 8"H post module can be used on the very top of any post to achieve non-standard heights. Custom Hi-Lo parts will then be required. The use of a 34"H post will not allow for the passing of beltway electrical.

Specify the mouse hole location for end power electric. Reference Planning Guide for details. Top cap orientation must be specified to achieve the right top cap for the panel heights involved. If any panel in the post connection is lower than post height, than one must determine which cap is appropriate (consult Planning Guide, pages 58-60).



Beltway posts are only required when electrical runs through the post in a 90° or straight. Always specify the post height to match the tallest panel.

Applicable finishes are listed on page 5 and 6.

# Panel connection posts

## Generation 3 135°

Reff Profiles

description	h	pattern no.	Reg. post list (A/B/C profile)
 135° Tiled Post	34"	<b>R3135V34T</b> ( ) ( ) ( ) ( ) ( ) ( )	\$528.
	42"	<b>R3135V42T</b> ( ) ( ) ( ) ( ) ( ) ( )	661.
	49"	<b>R3135V49T</b> ( ) ( ) ( ) ( ) ( ) ( )	669.
	64"	<b>R3135V64T</b> ( ) ( ) ( ) ( ) ( ) ( )	819.
	79"	<b>R3135V79T</b> ( ) ( ) ( ) ( ) ( ) ( )	966.
 135° Mono Post	34"	<b>R3135V34F</b> ( ) ( ) ( ) ( ) ( ) ( )	528.
	42"	<b>R3135V42F</b> ( ) ( ) ( ) ( ) ( ) ( )	661.
	49"	<b>R3135V49F</b> ( ) ( ) ( ) ( ) ( ) ( )	669.
	64"	<b>R3135V64F</b> ( ) ( ) ( ) ( ) ( ) ( )	819.
	79"	<b>R3135V79F</b> ( ) ( ) ( ) ( ) ( ) ( )	966.

### Order Code

Example:	<b>R3135V34T</b>
<b>R3</b>	Reff Generation 3
<b>135V</b>	135° post
<b>34</b>	Height
<b>T</b>	Tiled
<b>(A)</b>	Flat top profile
<b>(1)</b>	Regular L top cap
<b>(6)</b>	6" base height
<b>(N)</b>	No base infeed raceway knock-out
<b>(B)</b>	Tile divider, black reveal
<b>W808</b>	Face side 1, fabric selection
<b>W808</b>	Face side 2, fabric selection
<b>V316</b>	Top cap finish, Maple
<b>111</b>	Base finish, Jet black

\*R3R2SLV is required when adding a Reff Generation 2 stacking module post to a Generation 3 base post and required when adding a Generation 3 stacking module post to a Generation 2 base post. Installation instructions will ship with the sleeve.

**Note: New top caps are required in these two applications. Refer to page 419.**

### Specification Information

To order please specify pattern number including:

1. Top cap profile
2. Top cap configuration
3. If L post, cover configuration  
1 = one piece
4. Base height option
5. Base infeed knock-out (optional)
6. Tile divider option/finish, if face type T
7. Finish, face covers  
(*fabric, V1, V2, V3 or painted to match laminate*)
8. Top cap finish  
i) Top trim profile A,B or C options:  
V1, V2, V3, P1, P2, P3 finishes  
ii) Top trim profile E options:  
AA-anodized aluminum or P1, P2, P3 finish listed on page 5 excluding silver
9. Base finish

#### 1. Face type:

(F) = Full height (monolithic look)  
(T) = Tiled

#### 2. Top profile:

A = Flat  
B = Square  
C = Bullnose  
E = Extruded Aluminum  
(Add \$25 list for this option)  
3. Top cap configuration:  
1 = Regular L or cap finish 2 adjacent sides (*applicable for L, T or X posts only*)  
2 = Regular T or cap finish 1 side (*applicable for T or X posts only*)  
3 = Regular X cap unfinished all 4 sides (*applicable for X posts only*)

4 = Cap finished 3 sides/high-low (*applicable for L, T, X or straight posts*)

5 = Cap finished 2 opposite sides/high-low (*applicable for X or straight posts only*)

#### 5. Base height:

4 = 4" base height  
6 = 6" base height (add \$47 list for this option)

6. Tile divider, optional if face type "tiled" and face finish "non-fabric"  
B = Black steel reveal or  
Specify AA for anodized aluminum look or painted option from page 5 excluding silver.

Specify AA-anodized aluminum or painted options excluding silver from page 5.

Specify the mouse hole location for end power electric. Reference Planning Guide for details. Top cap orientation must be specified to achieve the right top cap for the panel heights involved. If any panel in the post connection is lower than post height, than one must determine which cap is appropriate (consult Planning Guide, pages 58-60).

Applicable finishes are listed on page 5 and 6.

# Panel connection posts

## Generation 3 120°

description	h	pattern number	Re. post list (A/B/C profile)
120° Post	34"	<b>R3120Y34</b> ( ) ( ) ( )	\$368.
	42"	<b>R3120Y42</b> ( ) ( ) ( )	387.
	49"	<b>R3120Y49</b> ( ) ( ) ( )	399.
	64"	<b>R3120Y64</b> ( ) ( ) ( )	438.
	79"	<b>R3120Y79</b> ( ) ( ) ( )	478.

### Order Code

Example: <b>R3120Y34</b>	
<b>R3</b>	Reff Generation 3
<b>120V</b>	120° post
<b>34</b>	Height
<b>T</b>	Tiled
<b>(A)</b>	Top profile
<b>(4)</b>	Base height
<b>V316</b>	Top cap finish, Maple
<b>111</b>	Base finish, Jet black

### Specification Information

*To order please specify pattern number including:*

1. Top cap profile
2. Base height option
3. Top cap finish
  - i) Top trim profile A,B or C options:  
V1, V2, V3, P1, P2, P3 finishes
  - ii) Top trim profile E options:  
AA-anodized aluminum or P1, P2, P3 finish listed on page 5excluding silver
4. Base finish

*1. Top profile:*

- A = Flat
- B = Square
- C = Bullnose
- E = Extruded Aluminum  
(Add \$25 list for this option)

*2. Base height:*

- 4 = 4" base height
- 6 = 6" base height (add \$47 list for this option)

Specify AA for anodized aluminum look or painted option from page 5excluding silver.

# Panel trims and post covers for all applications

Reff Profiles

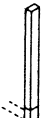
description	h	h	w	pattern no.	Profile (A/B/C)	Profile (E)
End trim with hookstrip 	–	34"		<b>R2ES34(A/B/C/E)(4/6)(E/N)</b>	\$216.	\$130.
	–	42"		<b>R2ES42(A/B/C/E)(4/6)(E/N)</b>	241.	152.
	–	49"		<b>R2ES49(A/B/C/E)(4/6)(E/N)</b>	267.	174.
	–	64"		<b>R2ES64(A/B/C/E)(4/6)(E/N)</b>	283.	196.
	–	79"		<b>R2ES79(A/B/C/E)(4/6)(E/N)</b>	347.	222.

End trim for Hi-Lo condition with hookstrip. Must order top trim below 	34"	42"		<b>R2HL3442ES(A/B/C/E)</b>	113.	115.
	34"	49"		<b>R2HL3449ES(A/B/C/E)</b>	157.	117.
	34"	64"		<b>R2HL3464ES(A/B/C/E)</b>	201.	120.
	34"	79"		<b>R2HL3479ES(A/B/C/E)</b>	216.	132.
	42"	49"		<b>R2HL4249ES(A/B/C/E)</b>	113.	115.
	42"	64"		<b>R2HL4264ES(A/B/C/E)</b>	272.	117.
	42"	79"		<b>R2HL4279ES(A/B/C/E)</b>	312.	132.
	49"	64"		<b>R2HL4964ES(A/B/C/E)</b>	157.	120.
	49"	79"		<b>R2HL4979ES(A/B/C/E)</b>	201.	132.
	64"	79"		<b>R2HL6479ES(A/B/C/E)</b>	157.	117.

\*\*Application: for height changes that DO NOT involve a post\*\*

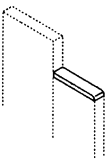
Top trim for Hi-Lo conditions (Notched one side) 	–		18"	<b>RSNTT18(A/B/C/E)</b>	80.	22.
	–	–	20"	<b>RSNTT20(A/B/C/E)</b>	80.	24.
	–	–	24"	<b>RSNTT24(A/B/C/E)</b>	89.	27.
	–	–	30"	<b>RSNTT30(A/B/C/E)</b>	99.	32.
	–	–	33"	<b>RSNTT33(A/B/C/E) (66" wide panels one only)</b>	103.	43.
	–	–	36"	<b>RSNTT36(A/B/C/E)</b>	110.	43.
	–	–	42"	<b>RSNTT42(A/B/C/E)</b>	125.	44.
	–	–	48"	<b>RSNTT48(A/B/C/E)</b>	135.	61.

## Order Code

Example: <b>R2ES34A6N</b>
<b>R2</b> Reff Generation 2
<b>ES</b> End trim
<b>34</b> 34" high
<b>A</b> Flat profile
<b>6</b> 6" base height
<b>N</b> Non electrical base
<b>V311</b> Beech
<b>111</b> Jet Black (base finish)

## Specification Information

To order please specify pattern number including:

End trim:

- Trim profile  
A = flat  
B = square  
C = bullnose  
E = extruded aluminum
- Base height option  
4 = 4"  
6 = 6"
- Base type  
E = electrical entry  
N = standard base
- Finish, end trim  
If profile A, B or C specify V1, V2, V3 or painted to match laminate  
If profile E specify AA-anodized aluminum or painted finish from page 5 excluding silver
- Finish, end trim base  
painted or plated finish

Applicable finishes are listed on page 5 and 6.

Post cover trim:

- Specify full or tiled face type  
F = full (monolithic)  
T = tiled
- Finish, post cover  
fabric, V1, V2, V3 or painted to match laminate
- If tiled cover set, specify reveal finish  
B = black reveal  
or select P1, P2, P3 painted finish from pg. 5

Select paint or plated finish from page 5.

**Add \$24 list for each end trim with 6"H base option.** Does not apply to hi-lo end trims as they have no base.

Top trims for Hi-Lo conditions need only be ordered for the connecting low panel of a Hi-Lo connection. Notched top trims required.

Post cover trim must be ordered for Hi-Lo conditions pertaining to posts. No notched top trim required.

Monolithic post covers are one piece. Tiled post covers will come in 8" and 15" pieces.

\*Notched transaction top must be ordered through Custom Product.

E profile end trim does not have base detail, but base height 4 or 6 required to determine overall height.

# Panel trims and post covers for all applications

description	h	h	w	pattern no.	Profile (A/B/C)	Profile (E)
End trim Hi-Lo with hookstrip* for transaction top (1 1/4" shorter than above trim)	42"	49"		<b>R2HL4249ETS(A/B/C/E)</b>	\$113.	\$115.
	42"	64"		<b>R2HL4264ETS(A/B/C/E)</b>	272.	117.
	42"	79"		<b>R2HL4279ETS(A/B/C/E)</b>	312.	132.



Post cover trim for tiled and monolithic posts Hi-Lo applications	34"	42"		<b>R2HL3442(F)CS ( )</b>	32.	
	34"	49"		<b>R2HL3449(F)CS ( )</b>	47.	
	34"	64"		<b>R2HL3464(F/T)CS ( )( )</b>	93.	
	34"	79"		<b>R2HL3479(F/T)CS ( )( )</b>	138.	
	42"	49"		<b>R2HL4249(F)CS ( )</b>	32.	
	42"	64"		<b>R2HL4264(F/T)CS ( )( )</b>	77.	
	42"	79"		<b>R2HL4279(F/T)CS ( )( )</b>	125.	
	49"	64"		<b>R2HL4964(F)CS ( )</b>	47.	
	49"	79"		<b>R2HL4979(F/T)CS ( )( )</b>	93.	
	64"	79"		<b>R2HL6479(F)CS ( )</b>	47.	



\*\*Application: for height changes involving a post\*\*

Order Code	Specification Information
Example: <b>R2ES34A6N</b>	<i>To order please specify pattern number including:</i>
<b>R2</b> Ref Generation 2	End trim:
<b>ES</b> End trim	1. Trim profile
<b>34</b> 34" high	<i>A = flat</i>
<b>A</b> Flat profile	<i>B = square</i>
<b>6</b> 6" base height	<i>C = bullnose</i>
<b>N</b> Non electrical base	<i>E = extruded aluminum</i>
<b>V311</b> Beech	2. Base height option
<b>111</b> Jet Black (base finish)	<i>4 = 4"</i>
	<i>6 = 6"</i>
	3. Base type
	<i>E = electrical entry</i>
	<i>N = standard base</i>
	4. Finish, end trim
	<i>If profile A, B or C specify V1, V2, V3 or painted to match laminate</i>
	<i>If profile E specify AA-anodized aluminum or painted finish from page 5 excluding silver</i>
	5. Finish, end trim base
	<i>painted or plated finish</i>
	Applicable finishes are listed on page 5 and 6.
	Post cover trim:
	1. Specify full or tiled face type
	<i>F = full (monolithic)</i>
	<i>T = tiled</i>
	2. Finish, post cover
	<i>fabric, V1, V2, V3 or painted to match laminate</i>
	3. If tiled cover set, specify reveal finish
	<i>B = black reveal</i>
	<i>or select P1, P2, P3 painted finish from pg. 5</i>
	Select paint or plated finish from page 5.
	<b>Add \$24 list for each end trim with 6"H base option.</b> Does not apply to hi-lo end trims as they have no base.
	Top trims for Hi-Lo conditions need only be ordered for the connecting low panel of a Hi-Lo connection. Notched top trims required.
	Post cover trim must be ordered for Hi-Lo conditions pertaining to posts. No notched top trim required.
	Monolithic post covers are one piece. Tiled post covers will come in 8" and 15" pieces.
	*Notched transaction top must be ordered through Custom Product.
	E profile end trim does not have base detail, but base height 4 or 6 required to determine overall height.

description	type	h	pattern no.	list price
 Ceiling entry L-post.		42"	<b>R2L42C(F/T)(F/T)-(4/6)</b>	\$237.
		49"	<b>R2L49C(F/T)(F/T)-(4/6)</b>	253.
		64"	<b>R2L64C(F/T)(F/T)-(4/6)</b>	269.
		79"	<b>R2L79C(F/T)(F/T)-(4/6)</b>	319.

*Cable not included*

 Ceiling entry T-post.		42"	<b>R2T42C(F/T)-(4/6)</b>	209.
		49"	<b>R2T49C(F/T)-(4/6)</b>	237.
		64"	<b>R2T64C(F/T)-(4/6)</b>	253.
		79"	<b>R2T79C(F/T)-(4/6)</b>	295.

*Cable not included*

 Ceiling entry X-post.		42"	<b>R2X42C</b>	193.
		49"	<b>R2X49C</b>	209.
		64"	<b>R2X64C</b>	237.
		79"	<b>R2X79C</b>	280.

*Cable not included*

 Ceiling entry straight line post.		42"	<b>R2S42C(F/T)(F/T)-(4/6)</b>	237.
		49"	<b>R2S49C(F/T)(F/T)-(4/6)</b>	253.
		64"	<b>R2S64C(F/T)(F/T)-(4/6)</b>	269.
		79"	<b>R2S79C(F/T)(F/T)-(4/6)</b>	319.

*Cable not included*

Order Code	Specification Information	Application Notes
Example: <b>R2L42CTT4</b> <b>R2</b> Reff Generation 2 <b>L</b> L-post <b>42</b> 42" high <b>C</b> Ceiling power entry <b>T</b> Tiled style face <b>T</b> Tiled style face <b>4</b> Base height <b>W230</b> Fabric selection <b>111</b> Jet Black (base finish)	<p><i>To order please specify pattern number including:</i></p> <ol style="list-style-type: none"> <li>1. Post face option</li> <li>2. Base height option</li> <li>3. Finish type, where applicable</li> <li>4. Finish, where applicable</li> <li>5. Base finish</li> <li>6. Canopy finish (ceiling entry pole only)</li> </ol> <p><i>1. Face type:</i>            F = Full height            T = Tiled</p> <p><i>2. Base height:</i>            4 = 4" base height            6 = 6" base height</p> <p><i>3. Finish type:</i>            F = Fabric            L = Laminate            1 = V1            2 = V2            3 = V3</p>	<p>Data cable application requires the post and the pole only.</p> <p>*Must order post, pole and cable for electrical application.</p> <p>The ceiling entry pole canopy is a trim piece used to finish off the ceiling where it was cut to accept the ceiling entry power pole.</p> <p>To determine pole height required, deduct panel height from ceiling height and add approximately 6". Ceiling entry pole to be used with posts shown.</p> <p>6"H base raceway option increase entire post height by 2 3/4". (Please add \$47 list per post for this option). Price does not apply to X-post.</p> <p>The Power pole must be specified with an indication towards a surface finish (fabric, laminate, techwood or veneer).</p> <p>Power pole and post combination do not allow the passage of power entry to beltway channel. All power from ceiling entry must travel to the base raceway and terminate at a power rail before traveling back up to the beltway inside the panel.</p> <p>Hi-lo ceiling post covers must be ordered in hi-lo applications from 114.</p>

Applicable finishes are listed on page 5 and 6.



description	type	h	pattern no.	list price
Ceiling entry pole. Includes junction box and ceiling grommet		41"	<b>RCP41-(F/L/1/2/3)*</b>	\$473.
		56"	<b>RCP56-(F/L/1/2/3)*</b>	491.
		71"	<b>RCP71-(F/L/1/2/3)*</b>	551.
		78"	<b>RCP78-(F/L/1/2/3)*</b>	569.



*Cable not included*

Power infeeds	Ceiling power cable infeed. Eight-wire	<b>RR3-EPVR</b>	276.
	Ceiling power cable infeed. Ten-wire	<b>RR3-TPVR</b>	334.
One size fits all post sizes (13' of cable) For use with Ceiling entry Pole and Pole combinations			



Order Code	Specification Information	Application Notes
Example: <b>R2L42CTT4</b>	<i>To order please specify pattern number including:</i>	Data cable application requires the post and the pole only.
<b>R2</b> Reff Generation 2	1. Post face option	*Must order post, pole and cable for electrical application.
<b>L</b> L-post	2. Base height option	
<b>42</b> 42" high	3. Finish type, where applicable	The ceiling entry pole canopy is a trim piece used to finish off the ceiling where it was cut to accept the ceiling entry power pole.
<b>C</b> Ceiling power entry	4. Finish, where applicable	To determine pole height required, deduct panel height from ceiling height and add approximately 6". Ceiling entry pole to be used with posts shown.
<b>T</b> Tiled style face	5. Base finish	6"H base raceway option increase entire post height by 2 3/4". (Please add \$47 list per post for this option). Price does not apply to X-post.
<b>T</b> Tiled style face	6. Canopy finish (ceiling entry pole only)	
<b>4</b> Base height	1. <i>Face type:</i>	
<b>W230</b> Fabric selection	F = Full height	
<b>111</b> Jet Black (base finish)	T = Tiled	
	2. <i>Base height:</i>	
	4 = 4" base height	
	6 = 6" base height	
	3. <i>Finish type:</i>	
	F = Fabric	
	L = Laminate	
	1 = V1	
	2 = V2	
	3 = V3	

Applicable finishes are listed on page 5 and 6.

The Power pole must be specified with an indication towards a surface finish (fabric, laminate, techwood or veneer).



Power pole and post combination do not allow the passage of power entry to beltway channel. All power from ceiling entry must travel to the base raceway and terminate at a power rail before traveling back up to the beltway inside the panel.

Hi-lo ceiling post covers must be ordered in hi-lo applications from 114.

# Ceiling cable entry post covers

## Alignment kits and wall starters

Reff Profiles

description	panel h	post h	w	h	pattern no.	list price
Ceiling entry post cover for Hi-Lo for monolithic or tiled applications 	34"	42"			<b>RPHL3442(F/T)</b>	\$32.
	34"	49"			<b>RPHL3449(F/T)</b>	47.
	34"	64"			<b>RPHL3464(F/T)</b>	93.
	34"	79"			<b>RPHL3479(F/T)</b>	138.
	42"	49"			<b>RPHL4249(F/T)</b>	64.
	42"	64"			<b>RPHL4264(F/T)</b>	89.
	42"	79"			<b>RPHL4279(F/T)</b>	97.
	49"	64"			<b>RPHL4964(F/T)</b>	89.
	49"	79"			<b>RPHL4979(F/T)</b>	97.
	64"	79"			<b>RPHL6479(F/T)</b>	70.
Ceiling entry post cover for Hi-Lo for stackable applications 	42"	49"			<b>RPHL4249S</b>	32.
	42"	64"			<b>RPHL4264S</b>	77.
	42"	79"			<b>RPHL4279S</b>	125.
	49"	64"			<b>RPHL4964S</b>	47.
	49"	79"			<b>RPHL4979S</b>	93.
	64"	79"			<b>RPHL6479S</b>	47.
Wall starter			7/8"	15"	<b>R2SWS0015 ( ) ( )</b>	59.
			7/8"	34"	<b>R2SWS0034 ( ) ( ) ( )</b>	117.
			7/8"	42"	<b>R2SWS0042 ( ) ( ) ( )</b>	143.
			7/8"	49"	<b>R2SWS0049 ( ) ( ) ( )</b>	167.
			7/8"	64"	<b>R2SWS0064 ( ) ( ) ( )</b>	219.
			7/8"	79"	<b>R2SWS0079 ( ) ( ) ( )</b>	270.
			7/8"	8"	<b>R2SWS0008 ( ) ( )</b>	45.

\*Wall starters come with extended top trim from adjoining panel.

Order Code	Specification Information	Application Notes
Example: <b>RPHL4249T</b>	<i>To order please specify pattern number including:</i>	These cover trims are for ceiling entry posts only.
<b>R</b> Reff	Ceiling entry post cover:	Wall starter is designed to attach panel run to interior walls and is available as a modular unit.
<b>P</b> Power post	1. Face type	Alignment kits help to improve the stability of panel runs. Extended top trim included. Extended top trim to be installed on adjacent panel to wall starter at install and will cap wall starter.
<b>HL</b> Hi lo cover	2. Select finish fabric, laminate or veneer	
<b>42</b> 42" low panel	<i>1. Face type options:</i>	
<b>49</b> 49" high panel	F = Full	
<b>T</b> Tiled face type	T = Tiled	
	Wall starter:	
	1. Pattern number including height	Ceiling Entry Post Covers are required to cover the exposed area of a post in a hi/low application.
	2. Adjoining panel width	Wall starters come with extended top trim from adjoining panel.
	3. Adjoining panel top trim profile (A, B, C or E)	
	4. Base height (4=4" or 6=6")	
	5. Top trim finish	
	Applicable finishes are listed on page 5 and 6.	
		Alignment kits are required for stacking modules and long panel runs. They are recommended when panels are supporting overhead storage. Please refer to planning guide for which alignment bracket to use for what condition.
		RSPA-BPD, BPP, BPW, BWD and BWW for use with generation 2 or 3 panels.
		RSPA-BPT, BTD, BTT and BTW for use with generation 2 only.
		R3SPA-BPT, BTD, BTT and BTW for use with generation 3 only.

# Ceiling cable entry post covers

## Alignment kits and wall starters

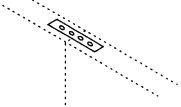
description	panel h	post h	w	h	pattern no.	list price
					<b>R3SPABPT</b>	\$7.
					<b>R3SPABTD</b>	7.
					<b>R3SPABTT</b>	7.
					<b>R3SPABTW</b>	7.
					<b>RSPABPD</b>	7.
					<b>RSPABPP</b>	7.
					<b>RSPABPT</b>	7.
					<b>RSPABPW</b>	7.
					<b>RSPABTD</b>	7.
					<b>RSPABTT</b>	7.
					<b>RSPABTW</b>	7.
					<b>RSPABWD</b>	7.
				<b>RSPABWW</b>	7.	

Suffix: BPT = for stacking module to panel, BTD = stacking module to door, BTT = stacking module to stacking module, BTW = stacking window to stacking module, BPD = panel to door, BPP = panel to panel

Order Code	Specification Information	Application Notes
Example: <b>RPHL4249T</b>	<i>To order please specify pattern number including:</i>	These cover trims are for ceiling entry posts only.
<b>R</b> Reff	Ceiling entry post cover:	Wall starter is designed to attach panel run to interior walls and is available as a modular unit.
<b>P</b> Power post	1. Face type	Alignment kits help to improve the stability of panel runs. Extended top trim included. Extended top trim to be installed on adjacent panel to wall starter at install and will cap wall starter.
<b>HL</b> Hi lo cover	2. Select finish fabric, laminate or veneer	Alignment kits are required for stacking modules and long panel runs. They are recommended when panels are supporting overhead storage. Please refer to planning guide for which alignment bracket to use for what condition.
<b>42</b> 42" low panel	<i>1. Face type options:</i>	RSPA-BPD, BPP, BPW, BWD and BWW for use with generation 2 or 3 panels.
<b>49</b> 49" high panel	F = Full	RSPA-BPT, BTD, BTT and BTW for use with generation 2 only.
<b>T</b> Tiled face type	T = Tiled	R3SPA-BPT, BTD, BTT and BTW for use with generation 3 only.
	Wall starter:	Ceiling Entry Post Covers are required to cover the exposed area of a post in a hi/low application.
	1. Pattern number including height	Wall starters come with extended top trim from adjoining panel.
	2. Adjoining panel width	
	3. Adjoining panel top trim profile (A, B, C or E)	
	4. Base height (4=4" or 6=6")	
	5. Top trim finish	
	Applicable finishes are listed on page 5 and 6.	

description	depth	w	h	pattern no.	list price	polycarbonate	clear glass	architectural
Rolling door	36"	64"		<b>RRDPPL(L/R)6436( )</b>	\$2,881.	\$2,983.	\$3,988.	
	36"	79"		<b>RRD3PPL(L/R)7936( )( )</b>	3,142.	3,254.	4,393.	
	42"	64"		<b>RRDPPL(L/R)6442( )</b>	2,936.	3,037.	4,038.	
	42"	79"		<b>RRD3PPL(L/R)7942( )( )</b>	3,190.	3,302.	4,441.	
Floor to ceiling rolling door	36"	79"		<b>RRD3FTCPPL(L/R)7936( )</b>	3,142.	3,254.	4,393.	
	42"	79"		<b>RRD3FTCPPL(L/R)7942( )</b>	3,190.	3,302.	4,441.	
Partial width threshold (full width threshold)	3"	50"		<b>RRDTH( )</b>	333.			
	3"	96"		<b>RRDTH(L/R)( )</b>	428.			
*Panel door right	(30" opening)	1 1/2"	36"	79"	<b>R2DRS7936( )( )</b>	3,752.		
	(36" opening)	1 1/2"	42"	79"	<b>R2DRS7942( )( )</b>	4,361.		
*Panel door left	(30" opening)	1 1/2"	36"	79"	<b>R2DLS7936( )( )</b>	3,752.		
	(36" opening)	1 1/2"	42"	79"	<b>R2DLS7942( )( )</b>	4,361.		



\*Woodgrain Laminate not available on Panel Door\*

### Order Code

Example:	<b>RRDPPL(L)6436(A)(4)</b>
<b>RRD</b>	Reff rolling door
<b>PPL</b>	Monolithic frame
<b>L</b>	Left hand
<b>64</b>	64" high
<b>36</b>	36" wide
<b>A</b>	Flat style top trim
<b>4"</b>	4" base height

### Specification Information

#### Hinged Door

To order hinged doors please specify:

1. Top trim profile
2. Base height
3. Lock option
4. Door finish
5. Top trim finish
6. Base finish

1. Top trim profile:

- A = Flat
- B = Square
- C = Bullnose

#### 2. Base height:

- 4 = 4" base
- 6 = 6" base (add \$47 for this option)

#### 3. Lock option:

- N = Not drilled
- D = Drilled \*
- L = Drilled lock set included
- D = \*Customer supplies own handle.

Reff doors are 1 1/2" thick, which must be considered when custom handle and lock sets are used.

#### Rolling Door

To order please specify the pattern number including:

1. Door hand left or right
2. Top trim profile
3. Base height
4. Trim finish
5. Base finish
6. Handle finish
7. Frame/Capture finish
8. Insert finish
9. Threshold (optional) and finish

#### Frame Insert Finish

Temp = Cleared tempered glass

#### Architectural options:

- GL13 = Powdered glass
- GL6 = Block matrix
- GL8 = Wafer glass
- P5 = Polycarbonate

### Application Notes

Applicable finishes are listed on page 5 and 6.

#### Hinged Door

- Hinged door frame matches door finish.
- Panel alignment kits required for door applications (see page 114).
- 6" base increases door height 2 3/4".
- Hinged door lock set is an ADA lever style handle in polished chrome.

#### Rolling Door

To meet ADA pull rating of 5 lbs., a partial or full width threshold must be specified.

The 42" wide door meets ADA width requirements. This door can be installed on all Reff Generation 2 panels. Rolling door base is not available in plated finishes. The frame, door handle, threshold, and base are all the same finish.

When specifying 79" h rolling doors, must specify panel top trim profiles A, B or C. Do not use with applications with panel top trim profile E, extruded aluminum.

For 64" h rolling door, one of the following support conditions must be existent:

1. Full height cabinet attached to the supporting post and panel
2. Worksurface and end panel OR worksurface and pedestal attached to the supporting post and panel

When installing the rolling door to Generation 1 panels, two R3AK kits must be specified.

No lock, no plated finishes available. Doors are handed. All attachment hardware comes shipped with the door including the capture and the stabilizer.

Threshold optional. Order separately. Threshold is available partial and full length. 29" opening on 36" wide door. 36" opening on 42" wide door.

R3/R2 stacking post sleeve required when adding a G2 stacking post to a G3 base post or a G3 stacking post to a G2 base post. Refer to Planning Guide for details.

Master key requests must be processed as a special request through Custom Product Development.

description	w	h	pattern no.	list price	
34"H panels to Generation 2 Beltway posts			<b>R234PKIT</b>	\$108.	
Generation 1 34"H panels to Generation 3 Beltway posts			<b>R334PKIT</b>	108.	
Generation 1 panel 42", 49", 64", 79" high to Generation 2 panels			<b>R2AK</b>	n/c	
Generation 1 panels to Generation 3 posts			<b>R3AK</b>	n/c	
R3/R2 stacking post sleeve			<b>R3R2SLV</b>	n/c	
Hookstrip cover reveal strip. (order separately for all panels)	10 Rolls	3/8"	79"	<b>RHSCN70</b>	n/c
	2 Rolls	3/8"	79"	<b>RHSCN15</b>	n/c
	30 Rolls	3/8"	79"	<b>RHSCN250</b>	n/c
	Carpet gripper(Pack of 10)			<b>R2CG</b>	19.

**Order Code**

Example:	<b>R234PKIT</b>
<b>R2</b>	Reff, generation 2
<b>34</b>	34" h panel to
<b>P</b>	Beltway post
<b>KIT</b>	Attachment kit

**Application Notes**

When installing the rolling door to Generation 1 panels, two R3AK kits must be specified.

R3/R2 stacking post sleeve required when adding a G2 stacking post to a G3 base post or a G3 stacking post to a G2 base post.

Refer to Planning Guide for details.

# Floor to ceiling modules

21" high, for 104" ceiling height and 79" high panels  
fabric and glass

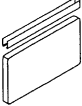
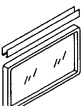
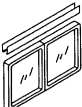
description	w	h	pattern no.	clear glass	arch. glass	grade						
						10	15	20	30	35	40	45
Stack-on floor to ceiling module Fabric both sides 	18"	21"	<b>R3FTCFF2118</b>			\$343.	\$349.	\$363.	\$425.	\$447.	\$509.	\$571.
	20"	21"	<b>R3FTCFF2120</b>			343.	349.	363.	425.	447.	509.	571.
	24"	21"	<b>R3FTCFF2124</b>			361.	367.	381.	443.	465.	527.	589.
	30"	21"	<b>R3FTCFF2130</b>			399.	405.	419.	481.	503.	565.	627.
	36"	21"	<b>R3FTCFF2136</b>			428.	434.	448.	510.	532.	594.	656.
	42"	21"	<b>R3FTCFF2142</b>			467.	473.	487.	549.	571.	633.	695.
	48"	21"	<b>R3FTCFF2148</b>			501.	507.	521.	583.	605.	667.	729.
Stack-on floor to ceiling window module. Single glass type "A" 	18"	21"	<b>RFTCWA2118</b>	481.	567.							
	20"	21"	<b>RFTCWA2120</b>	481.	567.							
	24"	21"	<b>RFTCWA2124</b>	505.	611.							
	30"	21"	<b>RFTCWA2130</b>	588.	716.							
	36"	21"	<b>RFTCWA2136</b>	615.	764.							
	42"	21"	<b>RFTCWA2142</b>	647.	827.							
	48"	21"	<b>RFTCWA2148</b>	678.	877.							
Stack-on floor to ceiling window module. Center mullion, type "B" 	30"	21"	<b>RFTCWB2130</b>	686.	812.							
	36"	21"	<b>RFTCWB2136</b>	744.	895.							
	42"	21"	<b>RFTCWB2142</b>	786.	960.							
	48"	21"	<b>RFTCWB2148</b>	822.	1,026.							

Order Code	Specification Information	Application Notes
Example: <b>R3FTCFF2118</b>	<i>To order please specify pattern number including:</i>	Panel glass is mounted flush to one side of window panel. All window panels incorporate tempered glass (4mm thick).  Specify the finish for frames from paint selection on page 5.  Add to all ceiling window modules on this page an upcharge of \$34 per module for P2 paint class options or \$64 per module per P3 paint class options.  Provide elevation drawing for mixed fabrics or veneers.  Alternative sizes from 21" to 37" in 1/2" increments are available through Custom Product Development.
<b>R3</b> Reff Generation 3	1. Pattern number	
<b>FTC</b> Floor to ceiling	2. Panel side 1 finish	
<b>FF</b> Fabric/fabric	3. Panel side 2 finish	
<b>21</b> 21" high	4. Soffit finish (paint)	<b>Knoll recommends that all office spaces requiring use of FTC components be laser leveled at both the floor and ceiling points to determine variance. This is critical to selecting the correct size components.</b>  <b>Use of Reff FTC modules must be approved by local building authorities.</b>  Refer to Reff Planning Guide, section 3 for floor-to-ceiling details prior to specifying.  No additional acoustic rating occurs on FTC installations.
<b>18</b> 18" wide	<i>For window panel:</i>	
<b>W281</b> Fabric selection - side 1	1. Pattern number	
<b>W281</b> Fabric selection - side 2	2. Frame finish	
<b>111</b> Jet Black soffit	3. Glass type	

# Floor to ceiling modules

25" high, for 108" ceiling height and 79" high panels  
fabric and glass

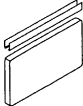
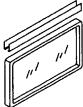
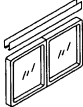
description	w	h	pattern no.	clear glass	arch. glass	grade						
						10	15	20	30	35	40	45
Stack-on floor to ceiling module Fabric both sides 	18"	25"	<b>R3FTCFF2518</b>			\$383.	\$389.	\$399.	\$483.	\$501.	\$583.	\$653.
	20"	25"	<b>R3FTCFF2520</b>			383.	389.	399.	483.	501.	583.	653.
	24"	25"	<b>R3FTCFF2524</b>			405.	411.	421.	505.	523.	605.	675.
	30"	25"	<b>R3FTCFF2530</b>			440.	446.	456.	540.	558.	640.	710.
	36"	25"	<b>R3FTCFF2536</b>			480.	487.	497.	581.	599.	681.	751.
	42"	25"	<b>R3FTCFF2542</b>			519.	525.	535.	619.	637.	719.	789.
	48"	25"	<b>R3FTCFF2548</b>			557.	563.	573.	657.	675.	757.	827.
Stack-on floor to ceiling window module. Single glass type "A" 	18"	25"	<b>RFTCWA2518</b>	502.	589.							
	20"	25"	<b>RFTCWA2520</b>	502.	589.							
	24"	25"	<b>RFTCWA2524</b>	537.	639.							
	30"	25"	<b>RFTCWA2530</b>	620.	748.							
	36"	25"	<b>RFTCWA2536</b>	650.	800.							
	42"	25"	<b>RFTCWA2542</b>	692.	866.							
	48"	25"	<b>RFTCWA2548</b>	721.	921.							
Stack-on floor to ceiling window module. Center mullion, type "B" 	30"	25"	<b>RFTCWB2530</b>	713.	837.							
	36"	25"	<b>RFTCWB2536</b>	789.	941.							
	42"	25"	<b>RFTCWB2542</b>	838.	1,014.							
	48"	25"	<b>RFTCWB2548</b>	885.	1,087.							

Order Code	Specification Information	Application Notes
Example: <b>R3FTCFF2518</b>	<i>To order please specify pattern number including:</i>	Panel glass is mounted flush to one side of window panel. All window panels incorporate tempered clear glass (4mm thick).  Specify the finish for frames from paint selection on page 5.  Add to all ceiling window modules on this page an upcharge of \$34 per module for P2 paint class options or \$64 per module per P3 paint class options.  Provide elevation drawing for mixed fabrics or veneers.  Alternative sizes from 21" to 37" in 1/2" increments are available through Custom Product Development.  Ceiling height includes 4" allowance for trim.
<b>R3</b> Reff Generation 3	1. Pattern number	
<b>FTC</b> Floor to ceiling	2. Panel side 1 finish	
<b>FF</b> Fabric/fabric	3. Panel side 2 finish	
<b>25</b> 25" high	4. Soffit finish (paint)	Metal top side plates allow for 2" adjustment downwards to allow for uneven floors.  <b>Knoll recommends that all office spaces requiring use of FTC components be laser leveled at both the floor and ceiling points to determine variance. This is critical to selecting the correct size components.</b>  <b>Use of Reff FTC modules must be approved by local building authorities.</b>  Refer to Reff Planning Guide, section 3 for floor-to-ceiling details prior to specifying.  No additional acoustic rating occurs on FTC installations.
<b>18</b> 18" wide	<i>For window panel:</i>	
<b>W281</b> Fabric selection - side 1	1. Pattern number	
<b>W281</b> Fabric selection - side 2	2. Frame finish	
<b>111</b> Jet Black soffit	3. Glass type	

# Floor to ceiling modules

37" high, for 120" ceiling height and 79" high panels  
fabric and glass

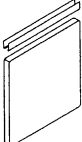
description	w	h	pattern no.	clear glass	arch. glass	grade						
						10	15	20	30	35	40	45
Stack-on floor to ceiling module Fabric both sides 	18"	37"	<b>R3FTCFF3718</b>			\$502.	\$506.	\$516.	\$640.	\$662.	\$784.	\$898.
	20"	37"	<b>R3FTCFF3720</b>			502.	506.	516.	640.	662.	784.	898.
	24"	37"	<b>R3FTCFF3724</b>			531.	535.	545.	669.	691.	813.	927.
	30"	37"	<b>R3FTCFF3730</b>			576.	580.	590.	714.	736.	858.	972.
	36"	37"	<b>R3FTCFF3736</b>			626.	630.	640.	764.	786.	908.	1,022.
	42"	37"	<b>R3FTCFF3742</b>			674.	678.	688.	812.	834.	956.	1,070.
	48"	37"	<b>R3FTCFF3748</b>			719.	723.	733.	857.	879.	1,001.	1,115.

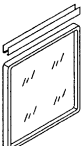
Stack-on floor to ceiling window module. Single glass type "A" 	18"	37"	<b>RFTCWA3718</b>	575.	660.
	20"	37"	<b>RFTCWA3720</b>	575.	660.
	24"	37"	<b>RFTCWA3724</b>	619.	720.
	30"	37"	<b>RFTCWA3730</b>	730.	842.
	36"	37"	<b>RFTCWA3736</b>	760.	909.
	42"	37"	<b>RFTCWA3742</b>	810.	984.
	48"	37"	<b>RFTCWA3748</b>	852.	1,058.

Stack-on floor to ceiling window module. Center mullion, type "B" 	30"	37"	<b>RFTCWB3730</b>	787.	915.
	36"	37"	<b>RFTCWB3736</b>	928.	1,078.
	42"	37"	<b>RFTCWB3742</b>	1,000.	1,175.
	48"	37"	<b>RFTCWB3748</b>	1,064.	1,268.

Order Code	Specification Information	Application Notes
Example: <b>R3FTCFF3718</b>	<i>To order please specify pattern number including:</i>	Panel glass is mounted flush to one side of window panel. All window panels incorporate tempered glass (4mm thick).
<b>R3</b> Reff Generation 3	1. Pattern number	Specify the finish for frames from paint selection on page 5.
<b>FTC</b> Floor to ceiling	2. Panel side 1 finish	Add to all ceiling window modules on this page an upcharge of \$34 per module for P2 paint class options or \$64 per module per P3 paint class options.
<b>FF</b> Fabric/fabric	3. Panel side 2 finish	Provide elevation drawing for mixed fabrics or veneers.
<b>37</b> 37" high	4. Soffit finish (paint)	Alternative sizes from 21" to 37" in 1/2" increments are available through Custom Product Development.
<b>18</b> 18" wide		Ceiling height includes 4" allowance for trim.
<b>W281</b> Fabric selection - side 1	<i>For window panel:</i>	Metal top side plates allow for 2" adjustment downwards to allow for uneven floors.
<b>W281</b> Fabric selection - side 2	1. Pattern number	<b>Knoll recommends that all office spaces requiring use of FTC components be laser leveled at both the floor and ceiling points to determine variance. This is critical to selecting the correct size components.</b>
<b>111</b> Jet Black soffit	2. Frame finish	<b>Use of Reff FTC modules must be approved by local building authorities.</b>
	3. Glass type	Refer to Reff Planning Guide, section 3 for floor-to-ceiling details prior to specifying.



# Floor to ceiling modules

21" and 25" high modules, fabric one side,  
laminate, techwood, conventional or exotic veneer other side

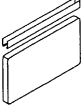
description	w	h	pattern no.	grade						
				10	15	20	30	35	40	45
Stack-on floor to ceiling module Fabric one side, laminate other side, 21" 	18"	21"	<b>R3FTCFL2118</b>	\$391.	\$393.	\$398.	\$432.	\$443.	\$475.	\$509.
	20"	21"	<b>R3FTCFL2120</b>	391.	393.	398.	432.	443.	475.	509.
	24"	21"	<b>R3FTCFL2124</b>	405.	407.	412.	446.	457.	489.	523.
	30"	21"	<b>R3FTCFL2130</b>	455.	457.	462.	496.	507.	539.	573.
	36"	21"	<b>R3FTCFL2136</b>	493.	495.	500.	534.	545.	577.	611.
	42"	21"	<b>R3FTCFL2142</b>	537.	539.	544.	578.	589.	621.	655.
	48"	21"	<b>R3FTCFL2148</b>	578.	580.	585.	619.	630.	662.	696.

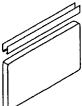
Stack-on floor to ceiling module Fabric one side, techwood other side, 21" 	18"	21"	<b>R3FTCF12118</b>	398.	400.	405.	439.	450.	482.	516.
	20"	21"	<b>R3FTCF12120</b>	398.	400.	405.	439.	450.	482.	516.
	24"	21"	<b>R3FTCF12124</b>	414.	416.	421.	455.	466.	498.	532.
	30"	21"	<b>R3FTCF12130</b>	461.	463.	468.	502.	513.	545.	579.
	36"	21"	<b>R3FTCF12136</b>	501.	503.	508.	542.	553.	585.	619.
	42"	21"	<b>R3FTCF12142</b>	542.	544.	549.	583.	594.	626.	660.
	48"	21"	<b>R3FTCF12148</b>	590.	592.	597.	631.	642.	674.	708.

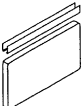
Stack-on floor to ceiling module Fabric one side, conventional veneer other side, 21" 	18"	21"	<b>R3FTCF22118</b>	406.	408.	413.	447.	458.	490.	524.
	20"	21"	<b>R3FTCF22120</b>	406.	408.	413.	447.	458.	490.	524.
	24"	21"	<b>R3FTCF22124</b>	419.	421.	426.	460.	471.	503.	537.
	30"	21"	<b>R3FTCF22130</b>	471.	473.	478.	512.	523.	555.	589.
	36"	21"	<b>R3FTCF22136</b>	509.	511.	516.	550.	561.	593.	627.
	42"	21"	<b>R3FTCF22142</b>	554.	556.	561.	595.	606.	638.	672.
	48"	21"	<b>R3FTCF22148</b>	598.	600.	605.	639.	650.	682.	716.

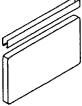
Stack-on floor to ceiling module Fabric one side, exotic veneer other side 21" 	18"	21"	<b>R3FTCF321 18</b>	535.	537.	542.	576.	587.	619.	653.
	20"	21"	<b>R3FTCF321 20</b>	535.	537.	542.	576.	587.	619.	653.
	24"	21"	<b>R3FTCF321 24</b>	553.	555.	560.	594.	605.	637.	671.
	30"	21"	<b>R3FTCF321 30</b>	623.	625.	630.	664.	675.	707.	741.
	36"	21"	<b>R3FTCF321 36</b>	674.	676.	681.	715.	726.	758.	792.
	42"	21"	<b>R3FTCF321 42</b>	734.	736.	741.	775.	786.	818.	852.
	48"	21"	<b>R3FTCF321 48</b>	792.	794.	799.	833.	844.	876.	910.

**Order Code**

Example:	<b>R3FTCFL2118</b>
<b>R3</b>	Reff Generation 3
<b>FTC</b>	Floor to ceiling
<b>FL</b>	Fabric/laminate
<b>21</b>	21" high
<b>18</b>	18" wide
<b>W281</b>	Fabric selection - side 1
<b>114</b>	Folkstone grey - side 2
<b>111</b>	Jet Black soffit

**Specification Information**

To order please specify pattern number including:

1. Pattern number
2. Panel side 1 finish
3. Panel side 2 finish
4. Soffit finish (paint)

Applicable finishes are listed on page 5 and 6.

**Application Notes**

Provide elevation drawing for mixed fabrics or veneers.

Alternative sizes from 21" to 37" in 1/2" increments are available through Custom Product Development.

Ceiling height includes 4" allowance for trim.

Metal top side plates allow for 2" (approx.) adjustment downwards to allow for uneven floors.

Modules on this page will not support the hanging of panel mount product.

**Knoll recommends that all office spaces requiring use of FTC components be laser leveled at both the floor and ceiling points to determine variance. This is critical to selecting the correct size components.**

**Use of Reff FTC modules must be approved by local building authorities.**

Refer to Reff Planning Guide, section 3 for floor-to-ceiling details prior to specifying.

# Floor to ceiling modules

21" and 25" high modules, fabric one side,  
laminate, techwood, conventional or exotic veneer other side

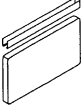
description	w	h	pattern no.	grade						
				10	15	20	30	35	40	45
Stack-on floor to ceiling module Fabric one side, laminate other side, 25" 	18"	25"	<b>R3FTCFL2518</b>	\$420.	\$423.	\$430.	\$474.	\$483.	\$525.	\$562.
	20"	25"	<b>R3FTCFL2520</b>	420.	423.	430.	474.	483.	525.	562.
	24"	25"	<b>R3FTCFL2524</b>	435.	438.	445.	489.	498.	540.	577.
	30"	25"	<b>R3FTCFL2530</b>	494.	497.	504.	548.	557.	599.	636.
	36"	25"	<b>R3FTCFL2536</b>	536.	539.	546.	590.	599.	641.	678.
	42"	25"	<b>R3FTCFL2542</b>	588.	591.	598.	642.	651.	693.	730.
	48"	25"	<b>R3FTCFL2548</b>	635.	638.	645.	689.	698.	740.	777.

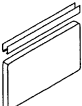
Stack-on floor to ceiling module Fabric one side, techwood other side, 25" 	18"	25"	<b>R3FTCF12518</b>	426.	429.	436.	480.	489.	531.	568.
	20"	25"	<b>R3FTCF12520</b>	426.	429.	436.	480.	489.	531.	568.
	24"	25"	<b>R3FTCF12524</b>	440.	443.	450.	494.	503.	545.	582.
	30"	25"	<b>R3FTCF12530</b>	504.	507.	514.	558.	567.	609.	646.
	36"	25"	<b>R3FTCF12536</b>	543.	546.	553.	597.	606.	648.	685.
	42"	25"	<b>R3FTCF12542</b>	598.	601.	608.	652.	661.	703.	740.
	48"	25"	<b>R3FTCF12548</b>	645.	648.	655.	699.	708.	750.	787.

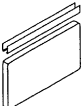
Stack-on floor to ceiling module Fabric one side, conventional veneer other side, 25" 	18"	25"	<b>R3FTCF22518</b>	435.	438.	445.	489.	498.	540.	577.
	20"	25"	<b>R3FTCF22520</b>	435.	438.	445.	489.	498.	540.	577.
	24"	25"	<b>R3FTCF22524</b>	448.	451.	458.	502.	511.	553.	590.
	30"	25"	<b>R3FTCF22530</b>	512.	515.	522.	566.	575.	617.	654.
	36"	25"	<b>R3FTCF22536</b>	555.	558.	565.	609.	618.	660.	697.
	42"	25"	<b>R3FTCF22542</b>	608.	611.	618.	662.	671.	713.	750.
	48"	25"	<b>R3FTCF22548</b>	657.	660.	667.	711.	720.	762.	799.

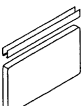
Stack-on floor to ceiling module Fabric one side, exotic veneer other side 25" 	18"	25"	<b>R3FTCF325 18</b>	569.	572.	579.	623.	632.	674.	711.
	20"	25"	<b>R3FTCF325 20</b>	569.	572.	579.	623.	632.	674.	711.
	24"	25"	<b>R3FTCF325 24</b>	591.	594.	601.	645.	654.	696.	733.
	30"	25"	<b>R3FTCF325 30</b>	674.	677.	684.	728.	737.	779.	816.
	36"	25"	<b>R3FTCF325 36</b>	734.	737.	744.	788.	797.	839.	876.
	42"	25"	<b>R3FTCF325 42</b>	805.	808.	815.	859.	868.	910.	947.
	48"	25"	<b>R3FTCF325 48</b>	871.	874.	881.	925.	934.	976.	1,013.

Order Code	Specification Information	Application Notes
Example: <b>R3FTCFL2118</b>	<i>To order please specify pattern number including:</i>	Provide elevation drawing for mixed fabrics or veneers.
<b>R3</b> Reff Generation 3	1. Pattern number	Alternative sizes from 21" to 37" in 1/2" increments are available through Custom Product Development.
<b>FTC</b> Floor to ceiling	2. Panel side 1 finish	
<b>FL</b> Fabric/laminate	3. Panel side 2 finish	
<b>21</b> 21" high	4. Soffit finish (paint)	
<b>18</b> 18" wide	Applicable finishes are listed on page 5 and 6.	Ceiling height includes 4" allowance for trim.
<b>W281</b> Fabric selection - side 1		Metal top side plates allow for 2" (approx.) adjustment downwards to allow for uneven floors.
<b>114</b> Folkstone grey - side 2		Modules on this page will not support the hanging of panel mount product.
<b>111</b> Jet Black soffit		

**Knoll recommends that all office spaces requiring use of FTC components be laser leveled at both the floor and ceiling points to determine variance. This is critical to selecting the correct size components.**

**Use of Reff FTC modules must be approved by local building authorities.**

Refer to Reff Planning Guide, section 3 for floor-to-ceiling details prior to specifying.

# Floor to ceiling modules

37" high modules, fabric one side,  
laminate, techwood, conventional or exotic veneer other side

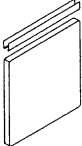
description	w	h	pattern no.	grade						
				10	15	20	30	35	40	45
Stack-on floor to ceiling module Fabric one side, laminate other side 	18"	37"	<b>R3FTCFL3718</b>	\$512.	\$514.	\$520.	\$584.	\$595.	\$659.	\$718.
	20"	37"	<b>R3FTCFL3720</b>	512.	514.	520.	584.	595.	659.	718.
	24"	37"	<b>R3FTCFL3724</b>	521.	523.	529.	593.	604.	668.	727.
	30"	37"	<b>R3FTCFL3730</b>	619.	621.	627.	691.	702.	766.	825.
	36"	37"	<b>R3FTCFL3736</b>	670.	672.	678.	742.	753.	817.	876.
	42"	37"	<b>R3FTCFL3742</b>	748.	750.	756.	820.	831.	895.	954.
	48"	37"	<b>R3FTCFL3748</b>	815.	817.	823.	887.	898.	962.	1,021.

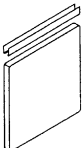
Stack-on floor to ceiling module Fabric one side, techwood other side 	18"	37"	<b>R3FTCF13718</b>	520.	522.	528.	592.	603.	667.	726.
	20"	37"	<b>R3FTCF13720</b>	520.	522.	528.	592.	603.	667.	726.
	24"	37"	<b>R3FTCF13724</b>	529.	531.	537.	601.	612.	676.	735.
	30"	37"	<b>R3FTCF13730</b>	629.	631.	637.	701.	712.	776.	835.
	36"	37"	<b>R3FTCF13736</b>	683.	685.	691.	755.	766.	830.	889.
	42"	37"	<b>R3FTCF13742</b>	764.	766.	772.	836.	847.	911.	970.
	48"	37"	<b>R3FTCF13748</b>	831.	833.	839.	903.	914.	978.	1,037.

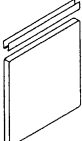
Stack-on floor to ceiling module Fabric one side, conventional veneer other side 	18"	37"	<b>R3FTCF23718</b>	528.	530.	536.	600.	611.	675.	734.
	20"	37"	<b>R3FTCF23720</b>	528.	530.	536.	600.	611.	675.	734.
	24"	37"	<b>R3FTCF23724</b>	540.	542.	548.	612.	623.	687.	746.
	30"	37"	<b>R3FTCF23730</b>	639.	641.	647.	711.	722.	786.	845.
	36"	37"	<b>R3FTCF23736</b>	692.	694.	700.	764.	775.	839.	898.
	42"	37"	<b>R3FTCF23742</b>	775.	777.	783.	847.	858.	922.	981.
	48"	37"	<b>R3FTCF23748</b>	847.	849.	855.	919.	930.	994.	1,053.

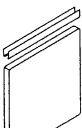
Stack-on floor to ceiling module Fabric one side, exotic veneer other side 37" 	18"	37"	<b>R3FTCF337 18</b>	689.	691.	697.	761.	772.	836.	895.
	20"	37"	<b>R3FTCF337 20</b>	689.	691.	697.	761.	772.	836.	895.
	24"	37"	<b>R3FTCF337 24</b>	707.	709.	715.	779.	790.	854.	913.
	30"	37"	<b>R3FTCF337 30</b>	840.	842.	848.	912.	923.	987.	1,046.
	36"	37"	<b>R3FTCF337 36</b>	912.	914.	920.	984.	995.	1,059.	1,118.
	42"	37"	<b>R3FTCF337 42</b>	1,024.	1,026.	1,032.	1,096.	1,107.	1,171.	1,230.
	48"	37"	<b>R3FTCF337 48</b>	1,120.	1,122.	1,128.	1,192.	1,203.	1,267.	1,326.

Order Code	Specification Information	Application Notes
Example: <b>R3FTCFL3718</b>	<i>To order please specify pattern number including:</i>	Provide elevation drawing for mixed fabrics or veneers.
<b>R3</b> Reff Generation 3	1. Pattern number	Alternative sizes from 21" to 37" in 1/2" increments are available through Custom Product Development.
<b>FTC</b> Floor to ceiling	2. Panel side 1 finish	Ceiling height includes 4" allowance for trim.
<b>FL</b> Fabric/laminate	3. Panel side 2 finish	Metal top side plates allow for 2" (approx.) adjustment downwards to allow for uneven floors.
<b>37</b> 37" high	4. Soffit finish (paint)	Modules on this page will not support the hanging of panel mount product.
<b>18</b> 18" wide	Applicable finishes are listed on page 5 and 6.	
<b>W281</b> Fabric selection - side 1		<b>Knoll recommends that all office spaces requiring use of FTC components be laser leveled at both the floor and ceiling points to determine variance. This is critical to selecting the correct size components.</b>
<b>114</b> Folkstone grey - side 2		<b>Use of Reff FTC modules must be approved by local building authorities.</b>
<b>111</b> Jet Black soffit		Refer to Reff Planning Guide, section 3 for floor-to-ceiling details prior to specifying.

# Floor to ceiling modules

## Panel connection posts

### for floor to ceiling applications

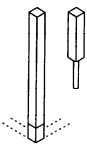
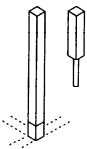
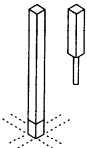
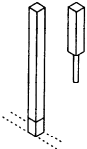
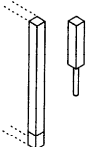
description		h	pattern no.	list price
 L-Post	add on	21"	<b>R3FTCL21</b>	\$180.
	add on	25"	<b>R3FTCL25</b>	200.
	add on	37"	<b>R3FTCL37</b>	258.
	full height	104"	<b>R3FTCL104(F/T)(F/T)-( ) ( )</b>	408.
	full height	108"	<b>R3FTCL108(F/T)(F/T)-( ) ( )</b>	408.
	full height	120"	<b>R3FTCL120(F/T)(F/T)-( ) ( )</b>	408.
 T-Post	add on	21"	<b>R3FTCT21</b>	195.
	add on	25"	<b>R3FTCT25</b>	213.
	add on	37"	<b>R3FTCT37</b>	273.
	full height	104"	<b>R3FTCT104(F/T)-( ) ( )</b>	367.
	full height	108"	<b>R3FTCT108(F/T)-( ) ( )</b>	367.
	full height	120"	<b>R3FTCT120(F/T)-( ) ( )</b>	367.
 X-Post	add on	21"	<b>R3FTCX21</b>	178.
	add on	25"	<b>R3FTCX25</b>	197.
	add on	37"	<b>R3FTCX37</b>	257.
	full height	104"	<b>R3FTCX104</b>	337.
	full height	108"	<b>R3FTCX108</b>	337.
	full height	120"	<b>R3FTCX120</b>	337.
 Straight post	add on	21"	<b>R3FTCS21</b>	180.
	add on	25"	<b>R3FTCS25</b>	200.
	add on	37"	<b>R3FTCS37</b>	258.
	full height	104"	<b>R3FTCS104(F/T)(F/T)-( ) ( )</b>	408.
	full height	108"	<b>R3FTCS108(F/T)(F/T)-( ) ( )</b>	408.
	full height	120"	<b>R3FTCS120(F/T)(F/T)-( ) ( )</b>	408.
 End post	add on	21"	<b>R3FTCE21</b>	195.
	add on	25"	<b>R3FTCE25</b>	213.
	add on	37"	<b>R3FTCE37</b>	273.
	full height	104"	<b>R3FTCE104(F/T)(F/T)(F/T)-( ) ( )</b>	367.
	full height	108"	<b>R3FTCE108(F/T)(F/T)(F/T)-( ) ( )</b>	367.
	full height	120"	<b>R3FTCE120(F/T)(F/T)(F/T)-( ) ( )</b>	367.

Order Code	Specification Information	Application Notes
<b>Example: R3FTCL104TT-6N</b> <b>R3FTC</b> Reff Gen 3 Floor to ceiling <b>L</b> Corner post <b>104</b> 104" high (one piece) <b>TT</b> Tiled appearance <b>6</b> 6" base height <b>N</b> No base infeed raceway knock-out <b>W808</b> Fabric selection <b>111</b> Jet Black (base finish)	<i>To order please specify pattern number including:</i> <ol style="list-style-type: none"> <li>Post face option</li> <li>Base height option</li> <li>Base infeed raceway knock-out, (optional)</li> <li>Fabric selection</li> <li>Base color</li> </ol> <p>1. <i>Face type:</i>            F = Full height (monolithic look)            T = Tiled</p> <p>2. <i>Base height:</i>            4 = 4" base height            6 = 6" base height (add \$47 list for this option)</p> <p>3. <i>Electrical infeed post:</i>            L = Base infeed left face            M = Base infeed middle face            R = Base infeed right face            N = None</p>	<p>The posts on this page do not support the hanging of panel mount product above the 79"H panels.</p> <p>The posts on this page will not carry data or electrical cables from the ceiling. Contact custom product development for custom ceiling electrical requirements.</p> <p>If required, specify the mouse hole location (specification action 4) to create access for electrical infeeds.</p> <p>Left and Right hand locations are determined by facing the post in question from the outside of the station.</p> <p>Hookstrip cover reveal strips are no charge but must be ordered separately from page 117.</p> <p>Refer to Reff Planning Guide, section 3 for floor-to-ceiling details prior to specifying.</p>

# Required components for floor to ceiling applications

description	h	pattern no.	list price
FTC wall starter	21"	<b>RFTCWS21S</b>	\$58.
	25"	<b>RFTCWS25S</b>	74.
	37"	<b>RFTCWS37S</b>	89.
Ceiling channel 108* and stabilizer beam	108"	<b>RFTCC108</b>	213.
Caddy clips (box of 100)		<b>RFTCCLIPS</b>	308.
Caddy clip spacers (box of 100) (Required in addition to Caddy Clips, where ceiling tiles hang below T-Bar level.)		<b>RFTCSpace</b>	97.
Floor to ceiling stabilizer bracket for A or C window only, G2 tiled or mono panels (B window requires two pairs)		<b>RFTCWT (Pair)</b>	7.
Floor to ceiling beam bracket for top of a stacking module		<b>RFTCSM (Pair) for G2 only</b>	7.
		<b>R3FTCSM (Pair) for G3 only</b>	7.
Floor to ceiling beam bracket for top of a G1 panel		<b>RFTCG1 (Pair)</b>	7.
Floor to ceiling beam bracket for top of a door panel		<b>RFTCDR (Pair)</b>	7.

\*These brackets are to be used with hinge doors only.



Order Code	Specification Information	Application Notes
Example: <b>RFTCWS21S</b>	<p>To order please specify pattern number including:</p> <ol style="list-style-type: none"> <li>1. Fabric/laminate/wood options</li> <li>2. Paint option for metal soffit</li> </ol> <p>All floor to ceiling posts mimic the panel system post application.</p>	<p>*Ceiling channel must be field cut to the panel run length, or joined if forming extended runs.</p> <p>Ceiling channel comes with panel stabilizer beam. Ceiling stabilizer beam must be attached to the top of the 79"H portion of your wall before the ceiling modules can be attached.</p> <p><b>Please see the Planning Guide (pages 51-55) for detailed instructions on specifying and installing FTC components.</b></p> <p><b>Use of Reff FTC components must be approved by local building authorities.</b></p> <p>Refer to Reff Planning Guide, section 3 for floor-to-ceiling details prior to specifying.</p>
<b>R</b> Reff		
<b>FTC</b> Floor to ceiling		
<b>WS</b> Wall starter		
<b>21</b> 21" high		

# Power distribution components

## 2+2 Base Raceway

### four circuit, eight-wire raceway for panels

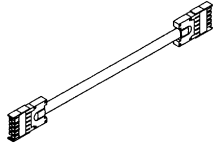
### power rails and connector

description	type	w	d	h	pattern no.	list price	
	24" panel	6"	2"	2"	<b>RR3-E24</b>	\$138.	
	30" panel	12"	2"	2"	<b>RR3-E30NS</b>	152.	
	36" panel	18"	2"	2"	<b>RR3-E36NS</b>	167.	
	42" panel	24"	2"	2"	<b>RR3-E42NS</b>	174.	
	48" panel	30"	2"	2"	<b>RR3-E48NS</b>	182.	
	60" panel	42"	2"	2"	<b>RR3-E60-4</b>	276.	
	66" panel	48"	2"	2"	<b>RR3-E66-4</b>	291.	
	72" panel	54"	2"	2"	<b>RR3-E72-4</b>	312.	
	Straight	16 1/2"	2"	2"	<b>RR3-EPC24</b>	80.	
		18 1/2"	2"	2"	<b>RR3-EPCS</b>	80.	
		20 1/4"	2"	2"	<b>RR3-EPC</b>	80.	
	Use <b>RR3-EPC24</b> for straight 24" to 24" wide panel. Use <b>RR3-EPCS</b> for straight 24" to any other width panel and for 30" to 30" wide panels. Use <b>RR3-EPC</b> for all other straight power connection configurations.						
	Through post	19"	2"	2"	<b>RR3-EPCP24</b>	80.	
		21"	2"	2"	<b>RR3-EPCPS</b>	80.	
		22 3/4"	2"	2"	<b>RR3-EPCP</b>	80.	
Use <b>RR3-EPCP24</b> for through post 24" to 24" wide panels. Use <b>RR3-EPCPS</b> for through post 24" to any other width panel and for 30" to 30" wide panels. Use <b>RR3-EPCP</b> for all other through post power connection configurations.							
	Circuit A				<b>RR3-DA</b>	38.	
	Circuit B				<b>RR3-DB</b>	38.	
	Circuit X				<b>RR3-DX</b>	38.	
	Circuit Y				<b>RR3-DY</b>	38.	
	Circuit X				<b>RR3-DXO</b>	43.	
	Circuit Y				<b>RR3-DYO</b>	43.	
Data Shield	1 pair				<b>RR3-DATSHD</b>	26.	

Order Code	Specification Information	Application Notes
Example: <b>RR3-E-24</b> <b>RR3</b> Reff raceway <b>E</b> Eight wire 2+2 <b>24</b> for 24" panel	Reff 2+2 Raceway is a four-circuit, eight-wire modular power distribution system for use in Reff panels. 2+2 Raceway components distribute two 20-amp convenience circuits (A and B) with neutral and ground, and two protected 20-amp circuits (X and Y) with separate neutral and ground. In Canada circuits carry 15 amp load resting.  Specify the suffix "RF" after the power rail pattern number for panels manufactured before June 1996.	Power rails are the primary power distribution component of the Reff 2+2 Raceway. Each rail provides outlet mounting positions on both sides and receptacles for two branching power connectors at each end. Center supports permit lay-in cabling from either side of the raceway.  Rail for 24" wide panel accepts one duplex outlet or power infeed centered on each side. Rails for 30" to 48" panels accept two outlets (or one outlet and one infeed) on each side. 60", 66" and 72"W panels accept four duplex outlets per side. Duplex outlets are preconfigured to access one of the four circuits, A, B, X, Y, and snap into any standard outlet location. Duplexes on circuits X and Y may be specified in orange to signify protected circuits for electronic equipment.
		Power connectors transmit power between adjacent powered panels. Specify straight power connector for straight connections and through-post power connector when passing in a 90° or straight through a T, X or L post connection.  Power connectors are enclosed in steel flexible conduit.  *Power connectors must be specified according to the panel widths in the specified orientation.  If separation of cabling and electrical wires is required, a data shield can be attached below the power rail. Data Shields are field installed.

# Power distribution components

## 2+2 Base Raceway

### four circuit, eight-wire raceway for panels

### jumpers and infeed

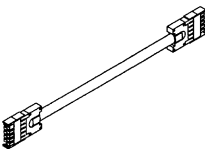
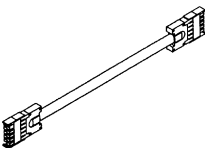
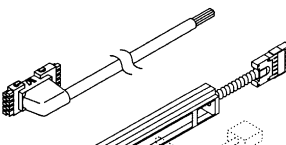
description	type	w	d	h	pattern no.	list price
 Jumper	18" panel	38"	2"	2"	<b>RR3-EJ18</b>	\$100.
	20" panel	40"	2"	2"	<b>RR3-EJ20</b>	100.
	24" panel	44"	2"	2"	<b>RR3-EJ24</b>	108.
	30" panel	50"	2"	2"	<b>RR3-EJ30</b>	116.
	36" panel	56"	2"	2"	<b>RR3-EJ36</b>	125.
	42" panel	62"	2"	2"	<b>RR3-EJ42</b>	131.
	48" panel	68"	2"	2"	<b>RR3-EJ48</b>	138.
	54" panel run	76 1/2"	2"	2"	<b>RR3-EJ54P</b>	145.
	60" panel run	82 1/2"	2"	2"	<b>RR3-EJ60P</b>	152.
	66" panel run	88 1/2"	2"	2"	<b>RR3-EJ66P</b>	160.
	72" panel run	94 1/2"	2"	2"	<b>RR3-EJ72P</b>	167.
	78" panel run	100 1/2"	2"	2"	<b>RR3-EJ78P</b>	174.
	84" panel run	106 1/2"	2"	2"	<b>RR3-EJ84P</b>	182.
	90" panel run	112 1/2"	2"	2"	<b>RR3-EJ90P</b>	190.
96" panel run	118 1/2"	2"	2"	<b>RR3-EJ96P</b>	197.	
 Extended jumper (through one post)	18" + post	40 1/2"	2"	2"	<b>RR3-EJ18P</b>	100.
	20" + post	42 1/2"	2"	2"	<b>RR3-EJ20P</b>	100.
	24" + post	46 1/2"	2"	2"	<b>RR3-EJ24P</b>	108.
	30" + post	52 1/2"	2"	2"	<b>RR3-EJ30P</b>	116.
	36" + post	58 1/2"	2"	2"	<b>RR3-EJ36P</b>	125.
	42" + post	64 1/2"	2"	2"	<b>RR3-EJ42P</b>	131.
	48" + post	70 1/2"	2"	2"	<b>RR3-EJ48P</b>	138.
 Power infeeds	Ceiling power cable infeed. Eight-wire				<b>RR3-EPVR</b>	276.
	Hardwire infeed (NYC) one direction				<b>RR3-EPNY1</b>	202.
	Hardwire infeed (NYC) two directions				<b>RR3-EPNY2</b>	303.
	Panel base end feed				<b>RR3-REPI</b>	240.
	Panel base side infeed				<b>RR3-EPI</b>	240.
	Surge suppressors				<b>RR3-SP-(A,B,X,Y)</b>	174.

## Order Code

Example:	<b>RR3-EPVR</b>
<b>RR3</b>	Reff raceway
<b>E</b>	Eight wire 2+2
<b>P</b>	power infeed
<b>VR</b>	for vertical raceway

## Specification Information

Reff 2+2 Raceway is a four-circuit, eight-wire modular power distribution system for use in Reff panels. 2+2 Raceway components distribute two 20-amp convenience circuits (A and B) with neutral and ground, and two 20-amp circuits (X and Y) with separate neutral and ground.

For use in Canada, all circuits are CGA rated 15 amp capacity.

*Note:*

For NYC hardwire infeeds specify bracket height: 4", 5", or 6"H.

Beltway panels can use jumpers at the panel base in a straight run or around a corner.

## Application Notes

Jumpers pass power through the raceway of panels that do not require power access to the next available power rail. Jumpers only connect to power rails. Jumpers 18" to 48" are available standard or extended. Extended jumpers should be specified when passing through a panel and a post. Jumpers 54" to 96" wide can be used with or without a post application. Extended jumpers and jumpers 54" to 96" wide can only pass through panels and one post.



Power infeeds connect building power supply to a cluster of interconnected power rails. Panel base infeed snaps into any outlet position in rail, and includes 6 foot liquid-tight conduit and pigtail for connection to floor or wall electrical box. Ceiling infeeds include up to 13' pigtail for connection

into panel base through power pole adjacent to panel with power rail. Power pole and post must be ordered separately.

Hardwire infeed, used in all New York City installations, includes junction box that mounts within non-powered panel base (any width 30" or greater). Electrical contractor supplies watertight conduit from building power supply to panel and trims power connectors to length. **RR3-EPNY2** includes two power connectors to power panels on both sides of infeed panel; **RR3-EPNY1** includes only one power connector.

Cable sizes are nominal. Use the "type" column to specify the required cable for your panel.

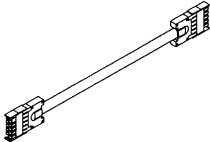
Power distribution components  
**3+3 Base Raceway**  
*six circuit, ten-wire raceway for panels*  
*power rails and connectors*

description	type	w	d	h	pattern no.	list price	
	24" panel	6"	2"	2"	<b>RR3-T24</b>	\$160.	
	30" panel	12"	2"	2"	<b>RR3-T30NS</b>	174.	
	36" panel	18"	2"	2"	<b>RR3-T36NS</b>	190.	
	42" panel	24"	2"	2"	<b>RR3-T42NS</b>	202.	
	48" panel	30"	2"	2"	<b>RR3-T48NS</b>	210.	
	60" panel	42"	2"	2"	<b>RR3-T60-4</b>	327.	
	66" panel	48"	2"	2"	<b>RR3-T66-4</b>	341.	
	72" panel	54"	2"	2"	<b>RR3-T72-4</b>	364.	
	Straight	16 1/2"	2"	2"	<b>RR3-TPC24</b>	100.	
		18 1/2"	2"	2"	<b>RR3-TPCS</b>	100.	
		20 1/4"	2"	2"	<b>RR3-TPC</b>	100.	
	Use <b>RR3-TPC24</b> for through post 24" to 24" wide panels. Use <b>RR3-TPCS</b> for through post 24" to any other width panel and for 30" to 30" wide panels. Use <b>RR3-TPC</b> for all other through post power connection configurations.						
	Through post	19"	2"	2"	<b>RR3-TPCP24</b>	100.	
		21"	2"	2"	<b>RR3-TPCPS</b>	100.	
		22 3/4"	2"	2"	<b>RR3-TPCP</b>	100.	
	Use <b>RR3-TPCP24</b> for through post 24" to 24" wide panels. Use <b>RR3-TPCPS</b> for through post 24" to any other width panel and for 30" to 30" wide panels. Use <b>RR3-TPCP</b> for all other through post power connection configurations.						
		Circuit A				<b>RR3-DA</b>	38.
		Circuit B				<b>RR3-DB</b>	38.
Circuit C					<b>RR3-DC</b>	38.	
Circuit X					<b>RR3-DX</b>	38.	
Circuit Y					<b>RR3-DY</b>	38.	
Circuit Z					<b>RR3-DZ</b>	38.	
	Circuit X				<b>RR3-DXO</b>	43.	
	Circuit Y				<b>RR3-DYO</b>	43.	
	Circuit Z				<b>RR3-DZO</b>	43.	
Data Shield	1 pair				<b>RR3-DATSHD</b>	26.	

Order Code	Specification Information	Application Notes
Example: <b>RR3-T-24</b> <b>RR3</b> Reff raceway <b>T</b> Ten wire 3+3 <b>24</b> for 24" panel	Reff 3+3 Raceway is a six-circuit, ten-wire modular power distribution system for use in Reff panels. 3+3 Raceway components distribute three 20-amp convenience circuits (A,B and C) with neutral and ground, and three 20-amp circuits (X, Y and Z) with separate neutral and ground.  A, B, X, Y outlets are identical to eight wire, 2+2 components.  Duplex outlet circuits are designated by white letters on black background.  In Canada, circuits carry a 15 amp load rating.  <i>Note:</i> Specify the suffix "RF" after the power rail pattern number for panels manufactured before June 1996.	Power rails are the primary power distribution component of the Reff 3+3 Raceway. Each rail provides outlet mounting positions on both sides and receptacles for branching power connectors at each end. Center supports permit lay-in cabling from either side of the raceway.  Rail for 24"W panel accepts one duplex outlet or power infeed one either side. Rails for 30" to 48" panels accept two outlets each side, 60", 66" and 72" rails accept four duplex outlets per side.  *Power connectors must be specified according to the panel widths in the specified orientation.
		Power connectors transmit power between adjacent powered panels. Specify straight power connector for straight connections and through-post power connector when passing in a 90° or straight through a T or X or L post connection.  Duplex outlets are preconfigured to access one of the four circuits, A, B, X, Y, and snap into any standard outlet location. Duplexes on circuits X and Y may be specified in orange to signify protected circuits for electronic equipment; all duplexes are black.  If separation of cabling and electrical wires is required, a data shield can be attached below the power rail. Data Shields are field installed.



# Power distribution components

## 3+3 Base Raceway

### six circuit, ten-wire raceway for panels

### jumpers and infeed

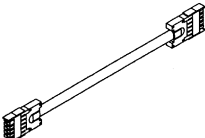
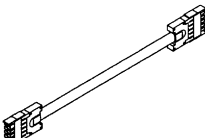
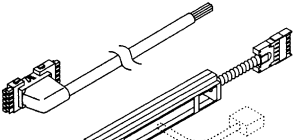
description	type	w	d	h	pattern no.	list price
	18" panel	38"	2"	2"	<b>RR3-TJ18</b>	\$116.
	20" panel	40"	2"	2"	<b>RR3-TJ20</b>	116.
	24" panel	44"	2"	2"	<b>RR3-TJ24</b>	125.
	30" panel	50"	2"	2"	<b>RR3-TJ30</b>	131.
	36" panel	56"	2"	2"	<b>RR3-TJ36</b>	138.
	42" panel	62"	2"	2"	<b>RR3-TJ42</b>	152.
	48" panel	68"	2"	2"	<b>RR3-TJ48</b>	167.
	54" panel run	76 1/2"	2"	2"	<b>RR3-TJ54P</b>	174.
	60" panel	82 1/2"	2"	2"	<b>RR3-TJ60P</b>	182.
	66" panel run	86 1/2"	2"	2"	<b>RR3-TJ66P</b>	190.
	72" panel run	94 1/2"	2"	2"	<b>RR3-TJ72P</b>	197.
	78" panel run	100 1/2"	2"	2"	<b>RR3-TJ78P</b>	202.
	84" panel run	106 1/2"	2"	2"	<b>RR3-TJ84P</b>	220.
90" panel run	112 1/2"	2"	2"	<b>RR3-TJ90P</b>	225.	
96" panel run	118 1/2"	2"	2"	<b>RR3-TJ96P</b>	231.	
	18" + post	40 1/2"	2"	2"	<b>RR3-TJ18P</b>	116.
	20" + post	46 1/2"	2"	2"	<b>RR3-TJ20P</b>	116.
	24" + post	46 1/2"	2"	2"	<b>RR3-TJ24P</b>	125.
	30" + post	52 1/2"	2"	2"	<b>RR3-TJ30P</b>	131.
	36" + post	58 1/2"	2"	2"	<b>RR3-TJ36P</b>	138.
	42" + post	64 1/2"	2"	2"	<b>RR3-TJ42P</b>	152.
	48" + post	70 1/2"	2"	2"	<b>RR3-TJ48P</b>	167.
	Ceiling power cable infeed. Ten-wire				<b>RR3-TPVR</b>	334.
	Hardwire infeed (NYC) one direction **				<b>RR3-TPNY1</b>	231.
	Hardwire infeed (NYC) two directions **				<b>RR3-TPNY2</b>	334.
	Panel base end feed				<b>RR3-RTPI</b>	276.
	Panel base side infeed				<b>RR3-TPI</b>	276.
	Surge suppressors *				<b>RR3-SP-(A, B, C, X, Y, Z)</b>	174.

\* Select which circuit needs protecting and order the specified surge processor.

\*\* For RR3-TPNY1 and RR3-TPNY2 specify base height of panel for NYC.

Order Code	Specification Information	Application Notes
Example: <b>RR3-TPVR</b> <b>RR3</b> Reff raceway <b>T</b> Ten wire 3+3 <b>P</b> power infeed <b>VR</b> for vertical raceway	<p>Reff 3+3 Raceway is a six-circuit, ten-wire modular power distribution system for use in Reff panels. 3+3 Raceway components distribute three 20-amp convenience circuits (A, B and C) with neutral and ground, and three 20-amp circuits (X, Y and Z) with separate neutral and ground.</p> <p>In Canada, circuits carry a 15 amp load rating.</p> <p>Power infeeds connect building power supply to a cluster of interconnected power rails. Panel base infeed snaps into any outlet position in rail, and includes 6 foot liquid-tight conduit and pigtail for connection to floor or wall electrical box. Ceiling infeeds include up to 13' pigtail for connection into panel base through standard power pole. Power pole and post must be ordered separately.</p>	<p>Jumpers pass power through the raceway of panels that do not require power access to the next available power rail. Jumpers only connect to power rails. Jumpers 18" to 48" are available standard or extended. Extended jumpers should be specified when passing through a panel and a post. Jumpers 54" to 96" wide can be used with or without a post application. Extended jumpers and jumpers 54" to 96" wide can only pass through panels and one post.</p> <p>Cable sizes are nominal. Use the "type" column to specify the required cable for your panel.</p> <p>Beltway panels can use jumpers at the panel base in a straight run or around a corner.</p>

# Power distribution components

## Hardwire box

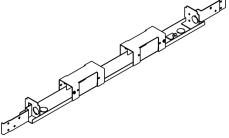
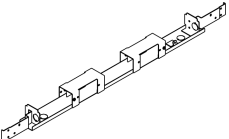
description	type	pattern no.	list
Chicago Hardwire Box 1 Sided 	24" panel	<b>RR3CHI241</b>	\$216.
	30" panel	<b>RR3CHI301</b>	250.
	36" panel	<b>RR3CHI361</b>	270.
	42" panel	<b>RR3CHI421</b>	273.
	48" panel	<b>RR3CHI481</b>	292.
Chicago Hardwire Box 2 Sided 	24" panel	<b>RR3CHI242</b>	223.
	30" panel	<b>RR3CHI302</b>	267.
	36" panel	<b>RR3CHI362</b>	274.
	42" panel	<b>RR3CHI422</b>	278.
	48" panel	<b>RR3CHI482</b>	311.

### Order Code

Example: <b>RR3CHI24</b>	
<b>RR3</b>	Reff/AutoStrada raceway G3
<b>CHI</b>	Chicago Hardwire Box
<b>24</b>	For 24" wide panel
<b>1</b>	One sided raceway

### Specification Information

Hardwire box is dedicated for panels with raceway either one or two sided, be sure to match to panel specification.

### Application Notes

Certified electrician to install.  
 Reff Hardwire Box  
 Installation instruction sheet available. Part number 6TR45715.

description	type	w	pattern no.	list price
One sided power rail for use with one sided Beltway Panel. Eight wire only. 2 sided beltway panels use standard base power rail.	24" panel		<b>RR3-E24S</b>	\$145.
	30" panel		<b>RR3-E30S</b>	167.
	36" panel		<b>RR3-E36S</b>	182.
	42" panel		<b>RR3-E42S</b>	197.
	48" panel		<b>RR3-E48S</b>	202.

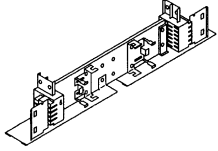

One sided power rail for use with one sided Beltway panel. Ten wire only	24" panel		<b>RR3-T24S</b>	174.
	30" panel		<b>RR3-T30S</b>	190.
	36" panel		<b>RR3-T36S</b>	202.
	42" panel		<b>RR3-T42S</b>	220.
	48" panel		<b>RR3-T48S</b>	225.

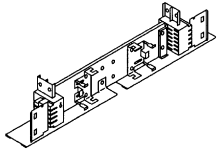

Beltway ribbon connector For eight or ten wire*	Beltway post	16 1/2"	<b>RR3-LTPC24</b>	100.
	Beltway post	19 1/2"	<b>RR3-LTPC</b>	100.
	Beltway post	21 1/2"	<b>RR3-LTPCP</b>	100.



Only necessary for post applications where cable will turn 90°ree.  
A standard power connector will go through a post in a straight run.

Vertical Jumper for linking base raceway and Beltway power rails in the same panel	For 30" wide Beltway panels (10 Wire)		<b>RR3-TBBCS</b>	145.
	For 30" wide Beltway panels (8 Wire)		<b>RR3-EBBCS</b>	137.
	For 36" to 48" wide Beltway panels (10 Wire)		<b>RR3-TBBCL</b>	153.
	For 36" to 48" wide Beltway panels (8 Wire)		<b>RR3-EBBCL</b>	145.

Order Code	Specification Information	Application Notes
Example: <b>RR3-T42S</b>		
<b>RR3</b> Reff raceway	Beltway ribbon connector used only to transition power around 90° turns. To go straight through a post condition at beltway use standard power connector.	Beltway power distribution is provided through the use of regular power rails in two sided Beltway panels and by single sided power rails in one sided Beltway panels. In order to turn 90° through this passage a ribbon connector must be specified. Straight Beltway panel to panel connections can use the standard group of jumpers and connectors from the preceding pages.
<b>T</b> Ten wire 3+3	Two side beltway panels use power rail for base.	<b>Vertical Adjacent Jumper</b> * *Power jumpers can be used to bring power to the beltway raceway from an adjacent panel's base raceway. This eliminates the need for a power rail in the base of the beltway panel. These are standard panel jumpers.
<b>42</b> For 42" panel	Single side beltway panel use one sided power rail for base.	<b>Vertical Jumper</b> When beltway panel base raceway contains a powerrail, the vertical jumper can be positioned in the base of the beltway panel and brought to the desk height location within the same panel.
<b>S</b> Single sided power	<i>Note:</i> When specifying 10 wire electrical you must order the appropriate 10 wire jumper to bring power to beltway from the adjacent panel.	Power cannot be transferred from base raceway to beltway raceway in 18", 20", and 24"W Reff beltway panels.
*Power connectors must be specified according to the panel widths in the specified orientation.		

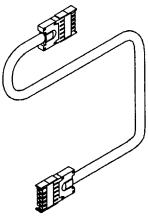
description	type	w	pattern no.	list price
Vertical Adjacent Jumper** For linking power to beltway from an adjacent panel 	24" wide Eight Wire		<b>RR3EJ48</b>	\$138.
	24" wide Ten Wire		<b>RR3TJ48</b>	167.
	30" wide Eight Wire		<b>RR3EJ60P</b>	152.
	30" wide Ten Wire		<b>RR3TJ60P</b>	182.
	36" wide Eight Wire		<b>RR3EJ60P</b>	152.
	36" wide Ten Wire		<b>RR3TJ60P</b>	182.
	42" wide Eight Wire		<b>RR3EJ66P</b>	160.
	42" wide Ten Wire		<b>RR3TJ66P</b>	190.
	48" wide Eight Wire		<b>RR3EJ72P</b>	167.
48" wide Ten Wire		<b>RR3TJ72P</b>	197.	

Order Code	Specification Information	Application Notes
Example: <b>RR3-T42S</b> <b>RR3</b> Reff raceway <b>T</b> Ten wire 3+3 <b>42</b> For 42" panel <b>S</b> Single sided power	Beltway ribbon connector used only to transition power around 90° turns. To go straight through a post condition at beltway use standard power connector.  Two side beltway panels use power rail for base.  Single side beltway panel use one sided power rail for base.  <i>Note:</i> When specifying 10 wire electrical you must order the appropriate 10 wire jumper to bring power to beltway from the adjacent panel.	Beltway power distribution is provided through the use of regular power rails in two sided Beltway panels and by single sided power rails in one sided Beltway panels. In order to turn 90° through this passage a ribbon connector must be specified. Straight Beltway panel to panel connections can use the standard group of jumpers and connectors from the preceding pages.  Power cannot be transferred from base raceway to beltway raceway in 18", 20", and 24"W Reff beltway panels.
		<b>Vertical Adjacent Jumper</b> **Power jumpers can be used to bring power to the beltway raceway from an adjacent panel's base raceway. This eliminates the need for a power rail in the base of the beltway panel. These are standard panel jumpers.  <b>Vertical Jumper</b> When beltway panel base raceway contains a powerrail, the vertical jumper can be positioned in the base of the beltway panel and brought to the desk height location within the same panel.

description	type	pattern no.	list price
Face plates	Cover, data jack (set of 10)	<b>RR3-FB</b>	\$14.
	Faceplate extender, black	<b>RR3-FE</b>	33.
	Three port faceplate, black	<b>RR3-3PF</b>	10.
	Two port faceplate, black	<b>RR3-2PF</b>	10.
Snap in module (must be used with faceplate)	BNC coupler, black	<b>RR3-BNC</b>	20.
	Cat 3 RJ11/14/25, black	<b>RR3-C3C</b>	13.
	CAT 5 RJ45 universal	<b>RR3-C5C</b>	20.
	CAT 6 universal	<b>RR3-C6C</b>	34.
	F series video coupler, black	<b>RR3-FV</b>	20.
	ST style coupler, black	<b>RR3-ST</b>	34.
Icons (sets of 10)	Data icons, 16 piece black	<b>RR3-DICON</b>	14.
	Mixed icons, 16 piece black	<b>RR3-MICON</b>	14.
	Phone icons, 16 piece black	<b>RR3PICON</b>	14.
Plate and module kits	4 Cat 5 RJ45-T568A extended face, black	<b>RR3-C5C4A</b>	135.
	4 Cat 5 RJ45-T568B extended face, black	<b>RR3-C5C4B</b>	135.
Fiber optics	Sc style dual fiber optic side mount	<b>RR3-FOSC</b>	171.
	ST style dual fiber optic side mount	<b>RR3-FOST</b>	97.
Desktop duplex monument	2-RJ11 (telephone)	<b>RGMD6</b>	103.
	2-RJ45's (phone and intercom)	<b>RGMD8</b>	115.
	Duplex outlet (electrical)	<b>RGMDE</b>	124.

Order Code	Specification Information	Application Notes
Example: <b>RR3-2PF</b>	All face plates and snap in modules are black.	Faceplate Extender is a 1/2" spacer which provides more depth for the faceplate to reside in, thereby increasing the space inside the Raceway.
<b>RR3</b> Reff raceway		
<b>2PF</b> Two port face	Icons can be ordered to distinguish intended use.	
Example: <b>RR3-C5CA</b>	*The RR3-C5C universal CAT 5 RJ45 module will accept EIA-T568A and EIA-T568B wiring methods.	Faceplates are ordered separately from snap in modules and can be configured on sight.
<b>RR3</b> Reff raceway		
<b>C5CA</b> Cat5 RJ45s	Face plates and plate kits snap into raceway openings on Reff Base Raceway and Reff Beltway.	See Planning Guide for drawings depicting the detail of the data modules.

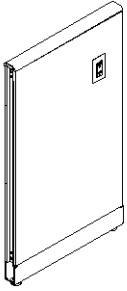

### Ported Panel Components

Reff ported panel components offer a cost effective alternative to using beltway panels which will provide users convenient access to data or power outlets at any user defined height on a Reff panel. Ports are one sided and may be installed below a worksurface, at desk height or even within a panel hung overhead storage unit.

Select option "Milled for ported components" when specifying panels. Ports may be added as technology needs change. Ports are field installed on the left or right hand side of a panel's vertical frame in either wood or fabric inserts. Installation instructions will be shipped with each kit, including a template for port placement along the vertical frame.

Panel jumpers are used to connect standard base electrical to the ported panel kit. Jumpers can be specified to connect a port within the same panel or to adjacent panels. Panel jumpers always pass through base raceway. If one port is installed, an additional port may be added within the same panel with an internal power jumper between the two ports. Ports can also be daisy-chained together in adjacent panels. Ported panel components are not available for stackable modules.

The kit includes a bracket set and cover plate and is ordered separately from the modular power components. Specify electrical components as you would for base raceway power then add the ported panel bracket kit, applicable duplexes and power jumpers.

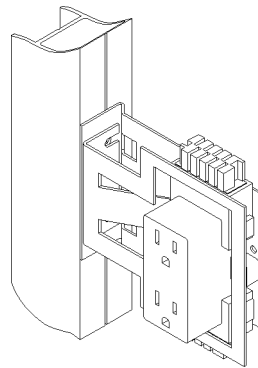
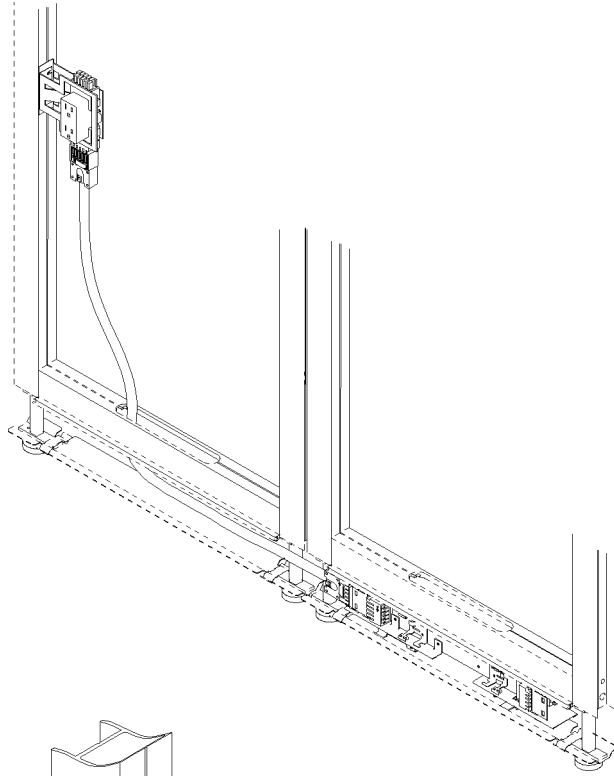

**Vertical power port bracket kit and duplex.**

# Reff Ported Panel Components

## port, vertical duplex and panel jumpers

description	type	pattern no.	list price
Port	Floating data port	<b>RR3FDP</b>	\$54.
	Vertical Power Port Bracket Kit (includes bracket, cover plate & installation instructions)	<b>RR3VPBK</b>	84.

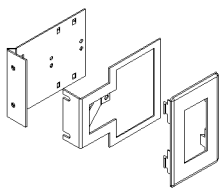

Vertical Duplex	Vertical Duplex A (8/10 wire applications)	<b>RR3VDA</b>	28.
	Vertical Duplex B (8/10 wire applications)	<b>RR3VDB</b>	28.
	Vertical Duplex C (10 wire applications)	<b>RR3VDC</b>	28.
	Vertical Duplex X (8/10 wire applications)	<b>RR3VDX</b>	28.
	Vertical Duplex X Iso (8/10 wire applications)	<b>RR3VDXO</b>	28.
	Vertical Duplex Y (8/10 wire applications)	<b>RR3VDY</b>	28.
	Vertical Duplex Y Iso (8/10 wire applications)	<b>RR3VDYO</b>	28.
	Vertical Duplex Z (10 wire applications)	<b>RR3VDZ</b>	28.
	Vertical Duplex Z Iso (10 wire applications)	<b>RR3VDZO</b>	28.

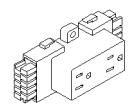

Same Panel Jumper, 8w	30" same Panel Jumper 50" 8w	<b>RR3EBVC50</b>	145.
	30" same Panel Jumper 64" 8w	<b>RR3EBVC64</b>	157.
	30" same Panel Jumper 78" 8w	<b>RR3EBVC78</b>	171.
	36" + same Panel Jumper 62" 8w	<b>RR3EBVC62</b>	156.
	36" + same Panel Jumper 76" 8w	<b>RR3EBVC76</b>	170.
	36" + same Panel Jumper 90" 8w	<b>RR3EBVC90</b>	185.

Same Panel Jumper, 10w	30" same Panel Jumper 50" 10w	<b>RR3TBVC50</b>	166.
	30" same Panel Jumper 64" 10w	<b>RR3TBVC64</b>	182.
	30" same Panel Jumper 78" 10w	<b>RR3TBVC78</b>	199.
	36" + same Panel Jumper 62" 10w	<b>RR3TBVC62</b>	178.
	36" + same Panel Jumper 76" 10w	<b>RR3TBVC76</b>	195.
	36" + same Panel Jumper 90" 10w	<b>RR3TBVC90</b>	210.

Order Code	Specification Information	Application Note
Example: <b>RR3VPBK</b>	For data and communications specify product listed on page 133.	30" same panel jumper only used if there is a harness in base of 30" panel . Length of panel jumper required driven by intended location of port. 50" will support port location in extreme top corner of 49"h 64" will support port location in extreme top corner of 64"h 78" will support port location in extreme top corner of 79"h
<b>RR3</b> Reff		
<b>VP</b> Vertical port		
<b>BK</b> Bracket kit		
	36"+ same panel jumper only used if there is a harness in the base of 36", 42" or 48" panels. Length of panel jumper required driven by intended location of port. 62" will support port location in extreme top corner of 49"h 76" will support port location in extreme top corner of 64"h 90" will support port location in extreme top corner of 79"h	If harness is in base of 24" panel you can not jump vertically, must remove harness.  A harness for Reff 30" wide panel with raceway on one side will only accept one same panel jumper. A duplex will not fit with the same panel jumper installed in the harness.  Internal panel jumper to be used within a panel, between two ports approximate span 48". Both duplex units must be the same circuit for this application.  Adjacent Panel Jumpers: 82" is max for 49" high panel 96" is max if panel is 64" high 110" is max if panel is 79" high  All covers plates and snap in modules are black.

# Reff Ported Panel Components

## *port, vertical duplex and panel jumpers*

Reff Profiles

description	type	pattern no.	list price
Adjacent Panel Jumper, 10w	Adjacent Panel Jumper 110" 10w	<b>RR3TVJ110</b>	\$227.
	Adjacent Panel Jumper 82" 10w	<b>RR3TVJ82</b>	196.
	Adjacent Panel Jumper 96" 10w	<b>RR3TVJ96</b>	213.

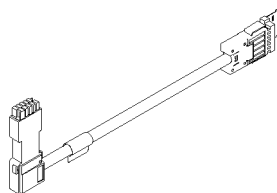

Adjacent Panel Jumper, 8w	Adjacent Panel Jumper 110" 8w	<b>RR3EVJ110</b>	200.
	Adjacent Panel Jumper 82" 8w	<b>RR3EVJ82</b>	174.
	Adjacent Panel Jumper 96" 8w	<b>RR3EVJ96</b>	189.

Internal Panel Jumper	Internal Panel Jumper 10 w	<b>RR3TVJ</b>	146.
	Internal Panel Jumper 8 w	<b>RR3EVJ</b>	135.

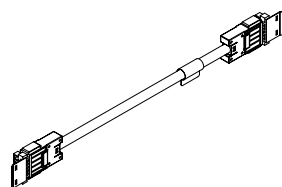

Order Code	Specification Information	Application Note
Example: <b>RR3VPBK</b>	For data and communications specify product listed on page 133.	<p>30" same panel jumper only used if there is a harness in base of 30" panel . Length of panel jumper required driven by intended location of port.</p> <p>50" will support port location in extreme top corner of 49"h 64" will support port location in extreme top corner of 64"h 78" will support port location in extreme top corner of 79"h</p> <p>36"+ same panel jumper only used if there is a harness in the base of 36", 42" or 48" panels. Length of panel jumper required driven by intended location of port.</p> <p>62" will support port location in extreme top corner of 49"h 76" will support port location in extreme top corner of 64"h 90" will support port location in extreme top corner of 79"h</p>
<b>RR3</b> Reff		
<b>VP</b> Vertical port		
<b>BK</b> Bracket kit		
		<p>If harness is in base of 24" panel you can not jump vertically, must remove harness.</p> <p>A harness for Reff 30" wide panel with raceway on one side will only accept one same panel jumper. A duplex will not fit with the same panel jumper installed in the harness.</p> <p>Internal panel jumper to be used within a panel, between two ports approximate span 48". Both duplex units must be the same circuit for this application.</p> <p>Adjacent Panel Jumpers: 82" is max for 49" high panel 96" is max if panel is 64" high 110" is max if panel is 79" high</p> <p>All covers plates and snap in modules are black.</p>

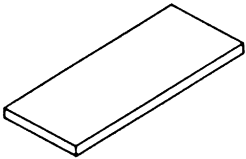

Worksurface 1 1/4"  
rectilinear  
20" and 24" deep

description	d	w	pattern no.	L	M/V1	V2	V3
Straight rectangular work tops 	20"	24"	<b>RSA241-()</b> ( )	\$309.	\$338.	\$389.	\$523.
		30"	<b>RSA301-()</b> ( )	339.	371.	425.	574.
		36"	<b>RSA361-()</b> ( )	358.	391.	449.	607.
		42"	<b>RSA421-()</b> ( )	372.	410.	470.	635.
		48"	<b>RSA481-()</b> ( )	391.	424.	488.	658.
		54"	<b>RSA541-()</b> ( )	406.	441.	510.	690.
		60"	<b>RSA601-()</b> ( )	439.	477.	549.	743.
		66"	<b>RSA661-()</b> ( )	449.	492.	567.	765.
		72"	<b>RSA721-()</b> ( )	475.	518.	594.	802.
		78"	<b>RSA781-()</b> ( )	481.	523.	603.	815.
		84"	<b>RSA841-()</b> ( )	510.	560.	642.	866.
		90"	<b>RSA901-()</b> ( )	534.	581.	667.	902.
	96"	<b>RSA961-()</b> ( )	553.	603.	693.	935.	
	24"	24"	<b>RSA242-()</b> ( )	325.	354.	410.	552.
		30"	<b>RSA302-()</b> ( )	368.	400.	463.	623.
		36"	<b>RSA362-()</b> ( )	380.	419.	479.	647.
		42"	<b>RSA422-()</b> ( )	396.	430.	495.	667.
		48"	<b>RSA482-()</b> ( )	420.	463.	531.	716.
		54"	<b>RSA542-()</b> ( )	449.	492.	567.	765.
		60"	<b>RSA602-()</b> ( )	485.	529.	606.	819.
		66"	<b>RSA662-()</b> ( )	497.	545.	628.	847.
		72"	<b>RSA722-()</b> ( )	522.	569.	656.	887.
78"		<b>RSA782-()</b> ( )	545.	596.	689.	928.	
84"	<b>RSA842-()</b> ( )	568.	621.	714.	964.		
90"	<b>RSA902-()</b> ( )	596.	648.	745.	1,004.		
96"	<b>RSA962-()</b> ( )	617.	673.	775.	1,046.		

Worksurfaces

Order Code	Specification Information	Application Notes
Example: <b>RSA241RL</b>	<i>To order please specify pattern number including:</i>	
<b>R</b> Reff	1. Top thickness	1 3/4" thick laminate option is double post formed front and back, all others are edgebanded.
<b>S</b> Straight top	2. Grommet option	Products on this page are shipped without hardware which must be ordered separately from the support components section.
<b>A</b> 1 1/4" thick	3. Top finish type	These worksurfaces are predrilled with metal inserts and use machine screws.
<b>24</b> 24" wide	4. Top finish	Mixed finish 1 3/4" tops are not post-formed.
<b>1</b> 20" deep	5. Grommet finish	Worksurface stiffeners recommended to provide additional support for open spans greater than 48" w.
<b>R</b> Recessed grommet option	1. <i>Thickness options:</i> A = 1 1/4"	
<b>L</b> Laminate finish	2. <i>Grommet options:</i> N = No grommets F = Flush front grommet location R = Recessed front (not recommended for 20"D and 24"D tops)	
<b>114</b> Folkstone grey	3. <i>Finish type:</i> L = Laminate M = Wood/laminate mixed 1 = V1 2 = V2 3 = V3	
<b>111</b> Jet Black (grommet)	4. <i>Top finish</i> 5. <i>Grommet finish:</i> Painted or Plated  Applicable finishes are listed on page 5 and 6.  Product on this page will accept woodgrain laminate where laminate is currently an option. List price for woodgrain laminate options will be current published laminate list price plus 10%.  <b>Knoll accepts no responsibility for special grommet locations which interfere with support or other hardware. All requests for special grommet locations must be approved through custom product development.</b>  <b>Actual widths of worksurfaces are 1/16" less than nominal dimension. Actual depth is 1/8" less.</b>	

Worksurface 1 1/4"  
 rectilinear  
 30" and 36" deep

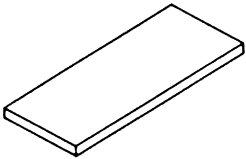
description	d	w	pattern no.	L	M/V1	V2	V3
Straight rectangular work tops 	30"	24"	<b>RSA243-()</b> ( )	\$355.	\$386.	\$442.	\$597.
		30"	<b>RSA303-()</b> ( )	399.	435.	500.	676.
		36"	<b>RSA363-()</b> ( )	428.	469.	538.	725.
		42"	<b>RSA423-()</b> ( )	446.	487.	561.	758.
		48"	<b>RSA483-()</b> ( )	477.	520.	597.	807.
		54"	<b>RSA543-()</b> ( )	516.	563.	645.	870.
		60"	<b>RSA603-()</b> ( )	535.	582.	669.	904.
		66"	<b>RSA663-()</b> ( )	544.	595.	688.	927.
		72"	<b>RSA723-()</b> ( )	560.	610.	701.	946.
		78"	<b>RSA783-()</b> ( )	585.	639.	735.	991.
		84"	<b>RSA843-()</b> ( )	607.	664.	764.	1,032.
		90"	<b>RSA903-()</b> ( )	637.	694.	800.	1,081.
		96"	<b>RSA963-()</b> ( )	659.	720.	828.	1,118.
		36"	60"	<b>RSA604-()</b> ( )	616.	672.	771.
66"	<b>RSA664-()</b> ( )		637.	695.	801.	1,082.	
72"	<b>RSA724-()</b> ( )		658.	719.	827.	1,117.	

**Order Code**

Example: <b>RSA243RL</b>
<b>R</b> Reff
<b>S</b> Straight top
<b>A</b> 1 1/4" thick
<b>24</b> 24" wide
<b>3</b> 30" deep
<b>R</b> Recessed grommet option
<b>L</b> Laminate finish
<b>114</b> Folkstone grey
<b>111</b> Jet Black (grommet)

**Specification Information**

To order please specify pattern number including:

1. Top thickness
2. Grommet option
3. Top finish type
4. Top finish
5. Grommet finish

1. *Thickness options:*  
 A = 1 1/4"

2. *Grommet options:*  
 N = No grommets  
 F = Flush front grommet location  
 R = Recessed front (not recommended for 20"D and 24"D tops)  
 A = Alternate location (for 36"D tops only)

3. *Finish type:*  
 L = Laminate  
 M = Wood/laminate mixed  
 1 = V1  
 2 = V2  
 3 = V3

4. *Top finish*

5. *Grommet finish:*  
 Painted or Plated

Applicable finishes are listed on page 5 and 6.

Product on this page will accept woodgrain laminate where laminate is currently an option. List price for woodgrain laminate options will be current published laminate list price plus 10%.

**Knoll accepts no responsibility for special grommet locations which interfere with support or other hardware. All requests for special grommet locations must be approved through custom product development.**

**Actual widths of worksurfaces are 1/16" less than nominal dimension. Actual depth is 1/8" less.**

**Application Notes**

1 3/4" thick laminate option is double post formed front and back, all others are edgebanded.

Products on this page are shipped without hardware which must be ordered separately from the support components section.

These worksurfaces are predrilled with metal inserts and use machine screws.

Mixed finish 1 3/4" tops are not post-formed.

Worksurface stiffeners recommended to provide additional support for open spans greater than 48"w.

# Worksurface 1 1/4" rectilinear corner tops

Reff Profiles

Worksurfaces

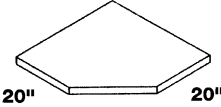
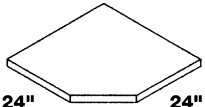
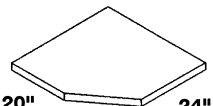
description	Return d	d	Back w	w	pattern no.	L	M/V1	V2	V3
20" Corner worktops, straight front corners 	20"	20"	36"	36"	<b>RKA 363611-</b> (-)(-)	\$636.	\$715.	\$822.	\$1,111.
	20"	20"	36"	42"	<b>RKA 364211-</b> (-)(-)	672.	759.	869.	1,173.
	20"	20"	36"	48"	<b>RKA 364811-</b> (-)(-)	714.	803.	925.	1,249.
	20"	20"	42"	36"	<b>RKA 423611-</b> (-)(-)	672.	759.	869.	1,173.
	20"	20"	42"	42"	<b>RKA 424211-</b> (-)(-)	714.	803.	925.	1,249.
	20"	20"	42"	48"	<b>RKA 424811-</b> (-)(-)	778.	877.	1,010.	1,362.
	20"	20"	48"	36"	<b>RKA 483611-</b> (-)(-)	714.	803.	925.	1,249.
	20"	20"	48"	42"	<b>RKA 484211-</b> (-)(-)	778.	877.	1,010.	1,362.
	20"	20"	48"	48"	<b>RKA 484811-</b> (-)(-)	820.	925.	1,062.	1,434.
24" Corner worktops, straight front corners 	24"	24"	36"	36"	<b>RKA 363622-</b> (-)(-)	722.	810.	932.	1,258.
	24"	24"	36"	42"	<b>RKA 364222-</b> (-)(-)	759.	854.	982.	1,325.
	24"	24"	36"	48"	<b>RKA 364822-</b> (-)(-)	799.	900.	1,033.	1,394.
	24"	24"	42"	36"	<b>RKA 423622-</b> (-)(-)	759.	854.	982.	1,325.
	24"	24"	42"	42"	<b>RKA 424222-</b> (-)(-)	799.	900.	1,033.	1,394.
	24"	24"	42"	48"	<b>RKA 424822-</b> (-)(-)	863.	974.	1,121.	1,512.
	24"	24"	48"	36"	<b>RKA 483622-</b> (-)(-)	799.	900.	1,033.	1,394.
	24"	24"	48"	42"	<b>RKA 484222-</b> (-)(-)	863.	974.	1,121.	1,512.
	24"	24"	48"	48"	<b>RKA 484822-</b> (-)(-)	907.	1,021.	1,172.	1,581.
20"/24" Corner worktops, straight front corners 	20"	24"	36"	36"	<b>RKA 363612-</b> (-)(-)	662.	745.	859.	1,158.
	20"	24"	36"	42"	<b>RKA 364212-</b> (-)(-)	700.	789.	905.	1,222.
	20"	24"	36"	48"	<b>RKA 364812-</b> (-)(-)	743.	835.	961.	1,296.
	20"	24"	42"	36"	<b>RKA 423612-</b> (-)(-)	700.	789.	905.	1,222.
	20"	24"	42"	42"	<b>RKA 424212-</b> (-)(-)	743.	835.	961.	1,296.
	20"	24"	42"	48"	<b>RKA 424812-</b> (-)(-)	810.	908.	1,047.	1,415.
	20"	24"	48"	36"	<b>RKA 483612-</b> (-)(-)	743.	835.	961.	1,296.
	20"	24"	48"	42"	<b>RKA 484212-</b> (-)(-)	810.	908.	1,047.	1,415.
	20"	24"	48"	48"	<b>RKA 484812-</b> (-)(-)	849.	957.	1,099.	1,484.

Order Code	
Example: <b>RKA363611N1</b>	
<b>R</b>	Reff
<b>K</b>	Straight front corner
<b>A</b>	1 1/4" top thickness
<b>36</b>	36" wide on left back
<b>36</b>	36" wide on right back
<b>1</b>	20" deep on left side
<b>1</b>	20" deep on right side
<b>N</b>	No grommet
<b>1</b>	V1 finish
<b>Y324</b>	Ash

Specification Information
<i>To order please specify pattern number including:</i>
1. Top thickness
2. Left hand width
3. Right hand width
4. Return left hand depth
5. Return right hand depth
6. Grommet option
7. Finish type
8. Top finish
9. Grommet finish
<i>1. Top thickness:</i> A = 1 1/4"
<i>2. Grommet options:</i> N = No grommets F = Standard corner location or Flush
<i>3. Finish type:</i> L = Laminate M = Wood/laminate mixed 1 = V1 2 = V2 3 = V3
<i>4. Top finish</i>
<i>5. Grommet finish:</i> Painted or Plated

Application Notes
Please call Custom Product Development for special grommet locations.
<b>Knoll accepts no responsibility for special grommet locations which interfere with support hardware.</b>
Products on this page are shipped without hardware which must be ordered separately from the support components section.
Product on this page will accept woodgrain laminate where laminate is currently an option. List price for woodgrain laminate options will be current published laminate list price plus 10%.
Mixed finish 1 3/4" tops are not post-formed.
These worksurfaces are predrilled with metal inserts and use machine screws.
Actual widths are 1/16" less all around on corner worksurfaces.
Applicable finishes are listed on page 5 and 6.

# Worksurface 1 1/4" rectilinear corner tops

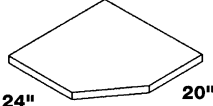
description	Return d	d	Back w	w	pattern no.	L	M/V1	V2	V3
24"/20" Corner worktops, straight front corners 	24"	20"	36"	36"	<b>RKA 363621-()()</b>	\$662.	\$745.	\$859.	\$1,158.
	24"	20"	36"	42"	<b>RKA 364221-()()</b>	700.	789.	905.	1,222.
	24"	20"	36"	48"	<b>RKA 364821-()()</b>	743.	835.	961.	1,296.
	24"	20"	42"	36"	<b>RKA 423621-()()</b>	700.	789.	905.	1,222.
	24"	20"	42"	42"	<b>RKA 424221-()()</b>	743.	835.	961.	1,296.
	24"	20"	42"	48"	<b>RKA 424821-()()</b>	810.	908.	1,047.	1,415.
	24"	20"	48"	36"	<b>RKA 483621-()()</b>	743.	835.	961.	1,296.
	24"	20"	48"	42"	<b>RKA 484221-()()</b>	810.	908.	1,047.	1,415.
	24"	20"	48"	48"	<b>RKA 484821-()()</b>	849.	957.	1,099.	1,484.

Order Code	Specification Information	Application Notes
Example: <b>RKA363611N1</b>	<i>To order please specify pattern number including:</i>	Please call Custom Product Development for special grommet locations.
<b>R</b> Reff	1. Top thickness	<b>Knoll accepts no responsibility for special grommet locations which interfere with support hardware.</b>
<b>K</b> Straight front corner	2. Left hand width	
<b>A</b> 1 1/4" top thickness	3. Right hand width	Products on this page are shipped without hardware which must be ordered separately from the support components section.
<b>36</b> 36" wide on left back	4. Return left hand depth	
<b>36</b> 36" wide on right back	5. Return right hand depth	Product on this page will accept woodgrain laminate where laminate is currently an option. List price for woodgrain laminate options will be current published laminate list price plus 10%.
<b>1</b> 20" deep on left side	6. Grommet option	
<b>1</b> 20" deep on right side	7. Finish type	Mixed finish 1 3/4" tops are not post-formed.
<b>N</b> No grommet	8. Top finish	
<b>1</b> V1 finish	9. Grommet finish	These worksurfaces are predrilled with metal inserts and use machine screws.
<b>Y324</b> Ash		
	1. <i>Top thickness:</i> A = 1 1/4"	
	2. <i>Grommet options:</i> N = No grommets F = Standard corner location or Flush	
	3. <i>Finish type:</i> L = Laminate M = Wood/laminate mixed 1 = V1 2 = V2 3 = V3	
	4. <i>Top finish</i>	
	5. <i>Grommet finish:</i> Painted or Plated	

# Worksurface 1 1/4" transition wave tops

Reff Profiles

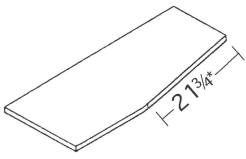
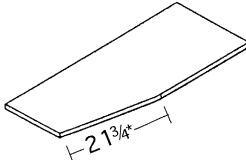
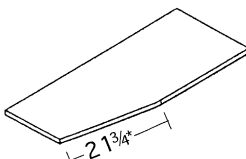
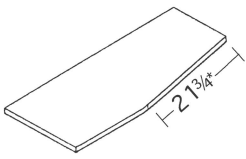
description	d	w	d	pattern no.	L	M/V1	V2	V3
Wave top transition (right 20") 	24"	42"	20"	<b>RWA4221-()</b> ( )	\$381.	\$432.	\$497.	\$672.
	24"	48"	20"	<b>RWA4821-()</b> ( )	403.	453.	521.	703.
	24"	54"	20"	<b>RWA5421-()</b> ( )	433.	485.	560.	756.
	24"	60"	20"	<b>RWA6021-()</b> ( )	461.	519.	596.	805.
	24"	66"	20"	<b>RWA6621-()</b> ( )	476.	536.	615.	829.
	24"	72"	20"	<b>RWA7221-()</b> ( )	496.	561.	643.	868.
Wave top transition (left 24") 	24"	36"	30"	<b>RWA3623-()</b> ( )	397.	448.	516.	695.
	24"	42"	30"	<b>RWA4223-()</b> ( )	414.	467.	536.	721.
	24"	48"	30"	<b>RWA4823-()</b> ( )	432.	483.	556.	751.
	24"	54"	30"	<b>RWA5423-()</b> ( )	463.	521.	600.	810.
	24"	60"	30"	<b>RWA6023-()</b> ( )	495.	560.	642.	866.
	24"	66"	30"	<b>RWA6623-()</b> ( )	514.	578.	665.	900.
	24"	72"	30"	<b>RWA7223-()</b> ( )	540.	607.	698.	941.
Wave top transition (left 20") 	20"	42"	24"	<b>RWA4212-()</b> ( )	381.	432.	497.	672.
	20"	48"	24"	<b>RWA4812-()</b> ( )	403.	453.	521.	703.
	20"	54"	24"	<b>RWA5412-()</b> ( )	433.	485.	560.	756.
	20"	60"	24"	<b>RWA6012-()</b> ( )	461.	519.	596.	805.
	20"	66"	24"	<b>RWA6612-()</b> ( )	476.	536.	615.	829.
	20"	72"	24"	<b>RWA7212-()</b> ( )	496.	561.	643.	868.
Wave top transition (right 24") 	30"	36"	24"	<b>RWA3632-()</b> ( )	397.	448.	516.	695.
	30"	42"	24"	<b>RWA4232-()</b> ( )	414.	467.	536.	721.
	30"	48"	24"	<b>RWA4832-()</b> ( )	432.	483.	556.	751.
	30"	54"	24"	<b>RWA5432-()</b> ( )	463.	521.	600.	810.
	30"	60"	24"	<b>RWA6032-()</b> ( )	495.	560.	642.	866.
	30"	66"	24"	<b>RWA6632-()</b> ( )	514.	578.	665.	900.
	30"	72"	24"	<b>RWA7232-()</b> ( )	540.	607.	698.	941.

Order Code	Specification Information	Application Notes
Example: <b>RWA4221FL</b>	<i>To order please specify pattern number including:</i>	32"D wave end top requires 20"D end panel for freestanding support.
<b>R</b> Reff	1. Left hand depth	36"D wave end top requires 24"D end panel for support.
<b>W</b> Wave top transition	2. Right hand depth	Products on this page are shipped without hardware which must be ordered separately from the support components section.
<b>A</b> 1 1/4" thick	3. Grommet option	These worksurfaces are predrilled with metal inserts and use machine screws.
<b>42</b> 42" wide	4. Top finish type	Curvilinear worksurfaces only available in 1 1/4" thick.
<b>2</b> 24" deep on left side	5. Top finish	See Planning Guide for grommet locations.
<b>1</b> 20" deep on right side	6. Grommet finish	Actual widths of worksurface are 1/16" less than nominal dimension. Actual depth is 1/8" less than nominal dimension.
<b>F</b> Flush grommet option	3. <i>Grommet options:</i>	
<b>L</b> Laminate finish	N = No grommet	
<b>114</b> Folkstone grey	F = Flush front grommet location	
<b>111</b> Jet Black (grommet)	4. <i>Finish type:</i>	
	L = Laminate	
	M = Wood/laminate mixed	
	1 = V1	
	2 = V2	
	3 = V3	
	5. <i>Top finish</i>	
	6. <i>Grommet finish:</i>	
	Painted or Plated	
		Please call Custom Product Development for special grommet locations.
		<b>Knoll accepts no responsibility for special grommet locations which interfere with support or other hardware.</b>
		Slope section of top remains 2 1/4" on all tops. The straight section grows with length of top.
		Worksurface stiffeners recommended to provide additional support for open spans greater than 48"w.
		Applicable finishes are listed on page 5 and 6.
		Product on this page will accept woodgrain laminate where laminate is currently an option. List price for woodgrain laminate options will be current published laminate list price plus 10%.

# Worksurface 1 1/4" transition wave top ends

Reff Profiles

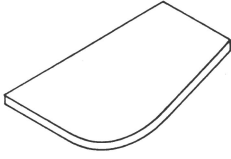
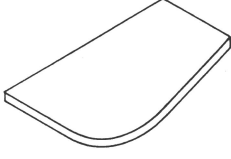
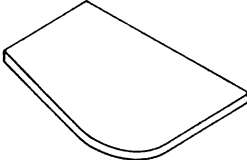
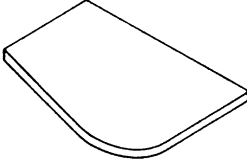
description	depth	w	d	pattern no.	L	M/V1	V2	V3
Wave top end, (right 20") 	20"	36"	32"	<b>RWEA3631-()()</b>	\$508.	\$572.	\$659.	\$889.
	20"	42"	32"	<b>RWEA4231-()()</b>	529.	595.	688.	927.
	20"	48"	32"	<b>RWEA4831-()()</b>	557.	629.	721.	974.
Wave top end, (right 24") 	24"	36"	36"	<b>RWEA3662-()()</b>	526.	593.	681.	919.
	24"	42"	36"	<b>RWEA4262-()()</b>	543.	611.	703.	949.
	24"	48"	36"	<b>RWEA4862-()()</b>	577.	647.	744.	1,003.
Wave top end, (left 20") 	32"	36"	20"	<b>RWEA3613-()()</b>	508.	572.	659.	889.
	32"	42"	20"	<b>RWEA4213-()()</b>	529.	595.	688.	927.
	32"	48"	20"	<b>RWEA4813-()()</b>	557.	629.	721.	974.
Wave top end, (left 24") 	36"	36"	24"	<b>RWEA3626-()()</b>	526.	593.	681.	919.
	36"	42"	24"	<b>RWEA4226-()()</b>	543.	611.	703.	949.
	36"	48"	24"	<b>RWEA4826-()()</b>	577.	647.	744.	1,003.

## Order Code

Example:	<b>RWEA3631FL</b>
<b>R</b>	Reff
<b>E</b>	Wave top ends
<b>A</b>	1 1/4" thick
<b>36</b>	36" wide
<b>3</b>	32" deep on left side
<b>1</b>	20" deep on right side
<b>F</b>	Flush grommet option
<b>L</b>	Laminate finish
<b>114</b>	Folkstone grey
<b>111</b>	Jet Black (grommet)

## Specification Information

To order please specify pattern number including:

1. Left hand depth
2. Right hand depth
3. Grommet option
4. Top finish type
5. Top finish
6. Grommet finish

3. Grommet options:  
N = No grommet  
F = Flush front grommet location

4. Finish type:  
L = Laminate  
M = Wood/laminate mixed  
1 = V1  
2 = V2  
3 = V3

5. Top finish

6. Grommet finish:  
Painted or Plated

Applicable finishes are listed on page 5 and 6.

Product on this page will accept woodgrain laminate where laminate is currently an option. List price for woodgrain laminate options will be current published laminate list price plus 10%.

## Application Notes

32"D wave end top requires 20"D end panel for freestanding support.

36"D wave end top requires 24"D end panel for support.

Products on this page are shipped without hardware which must be ordered separately from the support components section.

These worksurfaces are predrilled with metal inserts and use machine screws.

Curvilinear worksurfaces only available in 1 1/4" thick.

See Planning Guide for grommet locations.

Actual widths of worksurface are 1/16" less than nominal dimension. Actual depth is 1/8" less than nominal dimension.

Please call Custom Product Development for special grommet locations.

**Knoll accepts no responsibility for special grommet locations which interfere with support or other hardware.**

Slope section of top remains 21 3/4" on all tops. The straight section grows with length of top.

Worksurface stiffeners recommended to provide additional support for open spans greater than 48" w.

# Worksurface 1 1/4"

## curvilinear corner tops - 20" Deep

Reff Profiles

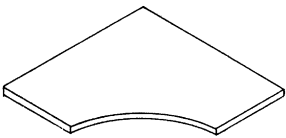
description	Return d	d	Back w	w	pattern no.	L	M/V1	V2	V3
Corner worktops, Curved front corner (Left return 20", Right return 20") 	20"	20"	36"	36"	<b>RCA363611</b> -()()	\$636.	\$715.	\$822.	\$1,111.
	20"	20"	36"	42"	<b>RCA364211</b> -()()	672.	759.	869.	1,173.
	20"	20"	36"	48"	<b>RCA364811</b> -()()	714.	803.	925.	1,249.
	20"	20"	42"	36"	<b>RCA423611</b> -()()	672.	759.	869.	1,173.
	20"	20"	42"	42"	<b>RCA424211</b> -()()	714.	803.	925.	1,249.
	20"	20"	42"	48"	<b>RCA424811</b> -()()	778.	877.	1,010.	1,362.
	20"	20"	48"	36"	<b>RCA483611</b> -()()	714.	803.	925.	1,249.
	20"	20"	48"	42"	<b>RCA484211</b> -()()	778.	877.	1,010.	1,362.
	20"	20"	48"	48"	<b>RCA484811</b> -()()	820.	925.	1,062.	1,434.
Corner worktops, Curved front corner (Left return 24", Right return 20")	24"	20"	36"	36"	<b>RCA363621</b> -()()	662.	745.	859.	1,158.
	24"	20"	36"	42"	<b>RCA364221</b> -()()	700.	789.	905.	1,222.
	24"	20"	36"	48"	<b>RCA364821</b> -()()	743.	835.	961.	1,296.
	24"	20"	42"	36"	<b>RCA423621</b> -()()	700.	789.	905.	1,222.
	24"	20"	42"	42"	<b>RCA424221</b> -()()	743.	835.	961.	1,296.
	24"	20"	42"	48"	<b>RCA424821</b> -()()	810.	908.	1,047.	1,415.
	24"	20"	48"	36"	<b>RCA483621</b> -()()	743.	835.	961.	1,296.
	24"	20"	48"	42"	<b>RCA484221</b> -()()	810.	908.	1,047.	1,415.
	24"	20"	48"	48"	<b>RCA484821</b> -()()	849.	957.	1,099.	1,484.

Worksurfaces

### Order Code

Example:	<b>RCA363611N1</b>
<b>R</b>	Reff
<b>C</b>	Curved front corner
<b>A</b>	1 1/4" thick
<b>36</b>	36" wide on left back
<b>36</b>	36" wide on right back
<b>1</b>	20" deep on left side
<b>1</b>	20" deep on right side
<b>N</b>	No grommet
<b>1</b>	V1 finish
<b>Y324</b>	Ash

### Specification Information

*To order please specify pattern number including:*

- Left hand width
- Right hand width
- Return left hand depth
- Return right hand depth
- Grommet option
- Top finish type
- Top finish
- Grommet finish

*5. Grommet options:*  
 N = No grommets  
 F = Standard corner location

*6. Finish type:*  
 L = Laminate  
 M = Wood/laminate mixed  
 1 = V1  
 2 = V2  
 3 = V3

*7. Top finish*

*8. Grommet finish:*  
 Painted or Plated

### Application Notes

Radius of curved front changes with overall top size. See Planning Guide.

Products on this page are shipped without hardware which must be ordered separately from the support components section.

Product on this page will accept woodgrain laminate where laminate is currently an option. List price for woodgrain laminate options will be current published laminate list price plus 10%.

These worksurfaces are predrilled with metal inserts and use machine screws.

Curvilinear worksurfaces only available in 1 1/4" thick.

See Planning Guide for grommet locations.

Actual widths of worksurface are 1/16" less than nominal dimension. Actual depth is 1/8" less than nominal dimension.

**Knoll accepts no responsibility for special grommet locations which interfere with support or other hardware.**

Please call Custom Product Development for special grommet locations.

Applicable finishes are listed on page 5 and 6.

# Worksurface 1 1/4" curvilinear corner tops - 24" Deep

Reff Profiles

description	Return d	d	Back w	w	pattern no.	L	M/V1	V2	V3
Corner worktops, Curved front corner (Left return 20", Right return 24")	20"	24"	36"	36"	<b>RCA363612-( )()</b>	\$662.	\$745.	\$859.	\$1,158.
	20"	24"	36"	42"	<b>RCA364212-( )()</b>	700.	789.	905.	1,222.
	20"	24"	36"	48"	<b>RCA364812-( )()</b>	743.	835.	961.	1,296.
	20"	24"	42"	36"	<b>RCA423612-( )()</b>	700.	789.	905.	1,222.
	20"	24"	42"	42"	<b>RCA424212-( )()</b>	743.	835.	961.	1,296.
	20"	24"	42"	48"	<b>RCA424812-( )()</b>	810.	908.	1,047.	1,415.
	20"	24"	48"	36"	<b>RCA483612-( )()</b>	743.	835.	961.	1,296.
	20"	24"	48"	42"	<b>RCA484212-( )()</b>	810.	908.	1,047.	1,415.
	20"	24"	48"	48"	<b>RCA484812-( )()</b>	849.	957.	1,099.	1,484.
Corner worktops, Curved front corner (Left return 24", Right return 24")	24"	24"	36"	36"	<b>RCA363622-( )()</b>	722.	810.	932.	1,258.
	24"	24"	36"	42"	<b>RCA364222-( )()</b>	759.	854.	982.	1,325.
	24"	24"	36"	48"	<b>RCA364822-( )()</b>	799.	900.	1,033.	1,394.
	24"	24"	42"	36"	<b>RCA423622-( )()</b>	759.	854.	982.	1,325.
	24"	24"	42"	42"	<b>RCA424222-( )()</b>	799.	900.	1,033.	1,394.
	24"	24"	42"	48"	<b>RCA424822-( )()</b>	863.	974.	1,121.	1,512.
	24"	24"	48"	36"	<b>RCA483622-( )()</b>	799.	900.	1,033.	1,394.
	24"	24"	48"	42"	<b>RCA484222-( )()</b>	863.	974.	1,121.	1,512.
	24"	24"	48"	48"	<b>RCA484822-( )()</b>	907.	1,021.	1,172.	1,581.

Order Code	Specification Information	Application Notes
Example: <b>RCA363612</b>	<i>To order please specify pattern number including:</i>	Radius of curved front changes with overall top size. See Planning Guide.
<b>R</b> Reff	1. Left hand width	Actual widths of worksurface are 1/16" less than nominal dimension. Actual depth is 1/8" less than nominal dimension.
<b>C</b> Curved front corner	2. Right hand width	<b>Knoll accepts no responsibility for special grommet locations which interfere with support or other hardware.</b>
<b>A</b> 1 1/4" thick	3. Return left hand depth	
<b>36</b> 36" wide on left back	4. Return right hand depth	Please call Custom Product Development for special grommet locations.
<b>36</b> 36" wide on right back	5. Grommet option	Applicable finishes are listed on page 5 and 6.
<b>1</b> 20" deep on left side	6. Top finish type	
<b>2</b> 24" deep on right side	7. Top finish	
<b>N</b> No grommet	8. Grommet finish	
<b>1</b> V1 finish	5. <i>Grommet options:</i>	
<b>Y324</b> Ash	N = No grommets	
	F = Standard corner location	
	6. <i>Finish type:</i>	These worksurfaces are predrilled with metal inserts and use machine screws.
	L = Laminate	Curvilinear worksurfaces only available in 1 1/4" thick.
	M = Wood/laminate mixed	
	1 = V1	
	2 = V2	
	3 = V3	
	7. <i>Top finish</i>	See Planning Guide for grommet locations.
	8. <i>Grommet finish:</i>	
	Painted or Plated	



# Worksurface 1 1/4" extended curvilinear corner tops

Reff Profiles

description	w	d	pattern no.	L	M/V1	V2	V3
Extended corner worktop, LH curved front corner (return 24")	36"	72"	<b>RCCDLA23672</b> ( ) ( ) ( )	\$1,756.	\$2,330.	\$3,289.	\$4,438.
	36"	78"	<b>RCCDLA23678</b> ( ) ( ) ( )	1,826.	2,423.	3,418.	4,615.
	36"	84"	<b>RCCDLA23684</b> ( ) ( ) ( )	1,899.	2,521.	3,555.	4,799.
	36"	96"	<b>RCCDLA23696</b> ( ) ( ) ( )	1,976.	2,621.	3,698.	4,993.

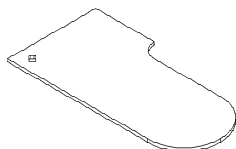

Extended corner worktop, LH curved front corner (return 30")	36"	72"	<b>RCCDLA33672</b> ( ) ( ) ( )	1,758.	2,336.	3,297.	4,451.
	36"	78"	<b>RCCDLA33678</b> ( ) ( ) ( )	1,828.	2,430.	3,431.	4,632.
	36"	84"	<b>RCCDLA33684</b> ( ) ( ) ( )	1,902.	2,528.	3,567.	4,815.
	36"	96"	<b>RCCDLA33696</b> ( ) ( ) ( )	1,978.	2,628.	3,711.	5,008.

Extended corner worktop, RH curved front corner (return 24")	36"	72"	<b>RCCDRA23672</b> ( ) ( ) ( )	1,756.	2,330.	3,289.	4,438.
	36"	78"	<b>RCCDRA23678</b> ( ) ( ) ( )	1,826.	2,423.	3,418.	4,615.
	36"	84"	<b>RCCDRA23684</b> ( ) ( ) ( )	1,899.	2,521.	3,555.	4,799.
	36"	96"	<b>RCCDRA23696</b> ( ) ( ) ( )	1,976.	2,621.	3,698.	4,993.

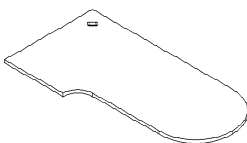

Extended corner worktop, RH curved front corner (return 30")	36"	72"	<b>RCCDRA33672</b> ( ) ( ) ( )	1,758.	2,336.	3,297.	4,451.
	36"	78"	<b>RCCDRA33678</b> ( ) ( ) ( )	1,828.	2,430.	3,431.	4,632.
	36"	84"	<b>RCCDRA33684</b> ( ) ( ) ( )	1,902.	2,528.	3,567.	4,815.
	36"	96"	<b>RCCDRA33696</b> ( ) ( ) ( )	1,978.	2,628.	3,711.	5,008.

Worksurfaces

## Order Code

## Specification Information

Example:	<b>RCCDLA23672N2</b>
<b>R</b>	Reff
<b>CC</b>	Curved corner
<b>D</b>	D top
<b>L</b>	Left Hand
<b>A</b>	1 1/4" thick
<b>2</b>	24" return
<b>36</b>	36" d at straight edge of corner, 30" across "D"
<b>72</b>	72" wide
<b>N</b>	No grommet
<b>2</b>	V2 finish
<b>V319</b>	Medium Cherry

*To order please specify pattern number including:*

1. Depth
2. Grommet option
3. Finish type
4. Finish
5. Grommet finish

*2. Grommet options:*  
 N = No grommets  
 F = Flush front grommet location

*3. Finish type:*  
 L = Laminate  
 M = Mixed (laminated surface with wood edge)  
 1 = V1  
 2 = V2  
 3 = V3

Applicable finishes are listed on page 5 and 6.

Product on this page will accept woodgrain laminate where laminate is currently an option.

List price for woodgrain laminate options will be current published laminate list price plus 10%.

These worksurfaces are predrilled with metal inserts and use machine screws.

Worksurface stiffeners are recommended to provide additional support for open spans greater than 48" w.

# Worksurface 1 1/4" extended straight corner tops

Reff Profiles

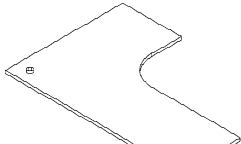
description	d	w	d, return	pattern no.	L	M/V1	V2	V3
Extended straight corner top, LH curved front corner (returns 24") 	36"	60"	24"	<b>RCEAL223660</b> ( ) ( ) ( )	\$650.	\$960.	\$1,299.	\$1,757.
	36"	72"	24"	<b>RCEAL223672</b> ( ) ( ) ( )	779.	1,164.	1,572.	2,123.
	42"	60"	24"	<b>RCEAL224260</b> ( ) ( ) ( )	715.	1,060.	1,436.	1,938.
	42"	72"	24"	<b>RCEAL224272</b> ( ) ( ) ( )	845.	1,266.	1,711.	2,309.
	48"	72"	24"	<b>RCEAL224872</b> ( ) ( ) ( )	911.	1,368.	1,846.	2,492.
	48"	84"	24"	<b>RCEAL224884</b> ( ) ( ) ( )	1,040.	1,572.	2,119.	2,861.
48"	96"	24"	<b>RCEAL224896</b> ( ) ( ) ( )	1,195.	1,812.	2,438.	3,292.	

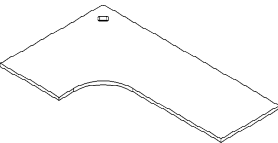
Extended straight corner top, RH curved front corner (returns 24") 	36"	60"	24"	<b>RCEAR223660</b> ( ) ( ) ( )	650.	960.	1,299.	1,757.
	36"	72"	24"	<b>RCEAR223672</b> ( ) ( ) ( )	779.	1,164.	1,572.	2,123.
	42"	60"	24"	<b>RCEAR224260</b> ( ) ( ) ( )	715.	1,060.	1,436.	1,938.
	42"	72"	24"	<b>RCEAR224272</b> ( ) ( ) ( )	845.	1,266.	1,711.	2,309.
	48"	72"	24"	<b>RCEAR224872</b> ( ) ( ) ( )	911.	1,368.	1,846.	2,492.
	48"	84"	24"	<b>RCEAR224884</b> ( ) ( ) ( )	1,040.	1,572.	2,119.	2,861.
	48"	96"	24"	<b>RCEAR224896</b> ( ) ( ) ( )	1,195.	1,812.	2,438.	3,292.

## Order Code

Example:	<b>RCEAL223660N2</b>
<b>R</b>	Reff
<b>C</b>	Corner
<b>E</b>	Extended
<b>A</b>	1 1/4" thick
<b>L</b>	Left Hand
<b>22</b>	24" returns
<b>36</b>	36" d at corner straight edge
<b>60</b>	60" wide
<b>N</b>	No grommet
<b>2</b>	V2 finish
<b>V319</b>	Medium Cherry

## Specification Information

To order please specify pattern number including:

1. Return left hand depth
2. Return right hand depth
3. Width
4. Depth
5. Grommet option
6. Finish type
7. Finish
8. Grommet finish

5. Grommet options:

- N = No grommets
- F = Flush front grommet location

6. Finish type:

- L = Laminate
- M = Mixed (laminated surface with wood edge)
- 1 = V1
- 2 = V2
- 3 = V3

Applicable finishes are listed on page 5 and 6.

Product on this page will accept woodgrain laminate where laminate is currently an option.

List price for woodgrain laminate options will be current published laminate list price plus 10%.

These worksurfaces are predrilled with metal inserts and use machine screws.

Worksurface stiffeners are recommended to provide additional support for open spans greater than 48" w.

# Worksurface 1 1/4"

## Meeting tops 'D'

Reff Profiles

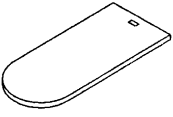
description	type	w	d	pattern no.	L	M/V1	V2	V3
 <p>Grommet choices are centered (as shown) or none</p>	36" deep	42"	36"	<b>RMDA4236-</b> ( ) ( )	\$617.	\$671.	\$770.	\$1,040.
		48"	36"	<b>RMDA4836-</b> ( ) ( )	676.	734.	843.	1,137.
		54"	36"	<b>RMDA5436-</b> ( ) ( )	770.	839.	966.	1,303.
		60"	36"	<b>RMDA6036-</b> ( ) ( )	865.	939.	1,082.	1,461.
		66"	36"	<b>RMDA6636-</b> ( ) ( )	883.	958.	1,101.	1,488.
		72"	36"	<b>RMDA7236-</b> ( ) ( )	894.	974.	1,121.	1,512.
		78"	36"	<b>RMDA7836-</b> ( ) ( )	1,009.	1,096.	1,261.	1,703.
		84"	36"	<b>RMDA8436-</b> ( ) ( )	1,121.	1,220.	1,403.	1,892.
		90"	36"	<b>RMDA9036-</b> ( ) ( )	1,182.	1,284.	1,478.	1,995.
		96"	36"	<b>RMDA9636-</b> ( ) ( )	1,296.	1,407.	1,618.	2,185.
	30" deep	42"	30"	<b>RMDA4230-</b> ( ) ( )	562.	609.	700.	945.
		48"	30"	<b>RMDA4830-</b> ( ) ( )	604.	658.	758.	1,023.
		54"	30"	<b>RMDA5430-</b> ( ) ( )	647.	705.	810.	1,094.
		60"	30"	<b>RMDA6030-</b> ( ) ( )	693.	755.	864.	1,168.
		66"	30"	<b>RMDA6630-</b> ( ) ( )	738.	802.	924.	1,248.
		72"	30"	<b>RMDA7230-</b> ( ) ( )	785.	853.	981.	1,324.
		78"	30"	<b>RMDA7830-</b> ( ) ( )	837.	963.	1,109.	1,495.
		84"	30"	<b>RMDA8430-</b> ( ) ( )	988.	1,074.	1,237.	1,669.
		90"	30"	<b>RMDA9030-</b> ( ) ( )	1,103.	1,200.	1,381.	1,862.
96"		30"	<b>RMDA9630-</b> ( ) ( )	1,218.	1,325.	1,523.	2,056.	
Wrap around panel top	(20" panels)	42 1/2"	21 1/4"	<b>RMDA4221-</b> ( ) ( )	722.	785.	901.	1,216.
	(24" panels)	50 1/2"	25 1/4"	<b>RMDA5025-</b> ( ) ( )	789.	859.	987.	1,334.



No Grommets

Please specify mating trim profile

Order Code	Specification Information	Application Notes
<p>Example: <b>RMDA4230N1</b></p> <p><b>R</b> Reff</p> <p><b>MD</b> Meeting D-top</p> <p><b>A</b> 1 1/4" thick</p> <p><b>42</b> 42" wide</p> <p><b>30</b> 30" deep</p> <p><b>N</b> No grommet</p> <p><b>1</b> V1</p> <p><b>Y311</b> Beech</p>	<p>To order please specify pattern number including:</p> <ol style="list-style-type: none"> <li>Top thickness</li> <li>Width</li> <li>Depth</li> <li>Grommet option</li> <li>Top finish type</li> <li>Top finish</li> <li>Grommet finish</li> <li>Trim profile</li> </ol> <p>1. Thickness options: A = 1 1/4"</p> <p>4. Grommet options: N = No grommet F = Flush front grommet location R = Recessed grommet location C = Centered (only on D-tops)</p> <p>5. Finish type: L = Laminate M = Wood/laminate mixed 1 = V1 2 = V2 3 = V3</p>	<p>Actual widths of worksurface are 1/16" less than nominal dimension. Actual depth is 1/8" less than nominal dimension.</p> <p><b>Additional spec option required for wrap around panel tops; specify mating trim profile.</b></p> <p>8. Trim profile <b>A = Flat</b> <b>B = Square</b> <b>C = Bullnose</b> <b>E = Extruded Aluminum</b></p> <p>Applicable finishes are listed on page 5 and 6.</p> <p>Product on this page will accept woodgrain laminate where laminate is currently an option. List price for woodgrain laminate options will be current published laminate list price plus 10%.</p> <p>See Planning Guide for standard grommet locations. D-top grommet location is always centered at flat end.</p> <p><b>Knoll assumes no responsibility for special grommet locations which interfere with support or other hardware.</b></p> <p>Refer to Planning Guide for modesty panel size requirements and all other support options.</p> <p>1 3/4" laminate tops on this page are edge banded to match post-formed contours.</p> <p>Products on this page are shipped without hardware which must be ordered separately from the support components section.</p> <p>These worksurfaces are predrilled with metal inserts and use machine screws.</p> <p>*Grommet option on elliptical tops is (R) for recessed or (N) for none. Refer to Planning Guide for specific grommet dimensions.</p> <p>Worksurface stiffeners are recommended to provide additional support for open spans greater than 48"w.</p>

Worksurfaces

# Worksurface 1 1/4" Meeting tops P and 9

Reff Profiles

description	type	w	d	pattern no.	L	M/V1	V2	V3
Meeting 9-top		42"	30"	<b>RM9A4230-</b> ( ) ( )	\$769.	\$837.	\$962.	\$1,297.
Adjoining top must use 12" end panel and modesty panel to support		48"	36"	<b>RM9A4836-</b> ( ) ( )	855.	929.	1,070.	1,446.



No Grommets 42" diameter

Meeting P-top		42"	30"	<b>RMPA4230-</b> ( ) ( )	769.	837.	962.	1,297.
Adjoining top must use 12" end panel and modesty panel to support		48"	36"	<b>RMPA4836-</b> ( ) ( )	855.	929.	1,070.	1,446.

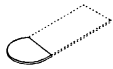

No Grommets 42" diameter

Worksurface 9-top		84"	30"	<b>RM9A8430-</b> ( ) ( )	1,566.	1,702.	1,958.	2,645.
		96"	30"	<b>RM9A9630-</b> ( ) ( )	1,631.	1,776.	2,039.	2,753.



42" diameter

Order Code	Specification Information	Application Notes
Example: <b>RM9A4230N1</b>	<i>To order please specify pattern number including:</i>	Actual widths of worksurface are 1/16" less than nominal dimension. Actual depth is 1/8" less than nominal dimension.
<b>R</b> Reff	1. Top thickness	1 3/4" laminate tops on this page are edge banded to match post-formed contours.
<b>M9</b> Meeting 9-top	2. Width	Products on this page are shipped without hardware which must be ordered separately from the support components section.
<b>A</b> 1 1/4" thick	3. Depth	These worksurfaces are predrilled with metal inserts and use machine screws.
<b>42</b> 42" wide	4. Grommet option	*Grommet option on elliptical tops is (R) for recessed or (N) for none. Refer to Planning Guide for specific grommet dimensions.
<b>30</b> 30" deep	5. Top finish type	Worksurface stiffeners are recommended to provide additional support for open spans greater than 48" w.
<b>N</b> No grommet	6. Top finish	
<b>1</b> V1	7. Grommet finish	
<b>Y311</b> Beech	1. <i>Thickness options:</i> A = 1 1/4"	Refer to Planning Guide for modesty panel size requirements and all other support options.
	4. <i>Grommet options:</i> N = No grommet F = Flush front grommet location R = Recessed grommet location C = Centered (only on D-tops)	
	5. <i>Finish type:</i> L = Laminate M = Wood/laminate mixed 1 = V1 2 = V2 3 = V3	
	7. <i>Grommet finish:</i> Painted or Plated	

# Worksurface 1 1/4"

## Meeting tops

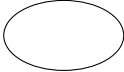
description	type	w	d	pattern no.	L	M/V1	V2	V3
 Worksurface P-top 42" diameter		84"	30"	<b>RMPA8430-</b> ( ) ( )	\$1,566.	\$1,702.	\$1,958.	\$2,645.
		96"	30"	<b>RMPA9630-</b> ( ) ( )	1,631.	1,776.	2,039.	2,753.
84" top uses a 42" modesty, 96 top uses a 54" modesty								
 Elliptical tops		60"	30"	<b>REBA6030-</b> ( ) *	1,077.	1,193.	1,369.	1,850.
		72"	42"	<b>REBA7242-</b> ( ) *	1,534.	1,696.	1,952.	2,634.
		78"	48"	<b>REBA7848-</b> ( ) *	1,680.	1,861.	2,140.	2,889.

Order Code	Specification Information	Application Notes
Example: <b>RMDA4230N1</b> <b>R</b> Reff <b>MD</b> Meeting D-top <b>A</b> 1 1/4" thick <b>42</b> 42" wide <b>30</b> 30" deep <b>N</b> No grommet <b>1</b> V1 <b>Y311</b> Beech	<p><i>To order please specify pattern number including:</i></p> <ol style="list-style-type: none"> <li>Top thickness</li> <li>Width</li> <li>Depth</li> <li>Grommet option</li> <li>Top finish type</li> <li>Top finish</li> <li>Grommet finish</li> <li>Trim profile</li> </ol> <p><i>1. Thickness options:</i> A = 1 1/4"</p> <p><i>4. Grommet options:</i> N = No grommet F = Flush front grommet location R = Recessed grommet location C = Centered (only on D-tops)</p> <p><i>5. Finish type:</i> L = Laminate M = Wood/laminate mixed 1 = V1 2 = V2 3 = V3</p> <p><i>7. Grommet finish:</i> Painted or Plated</p>	<p>Actual widths of worksurface are 1/16" less than nominal dimension. Actual depth is 1/8" less than nominal dimension.</p> <p>Applicable finishes are listed on page 5 and 6.</p> <p>Product on this page will accept woodgrain laminate where laminate is currently an option.</p> <p>List price for woodgrain laminate will be current published laminate list price plus 10%.</p> <p>See Planning Guide for standard grommet locations. D-top grommet location is always centered at flat end.</p> <p><b>Knoll assumes no responsibility for special grommet locations which interfere with support or other hardware.</b></p> <p>Refer to Planning Guide for modesty panel size requirements and all other support options.</p> <p>1 3/4" laminate tops on this page are edge banded to match post-formed contours.</p> <p>Products on this page are shipped without hardware which must be ordered separately from the support components section.</p> <p>These worksurfaces are predrilled with metal inserts and use machine screws.</p> <p>*Grommet option on elliptical tops is (R) for recessed or (N) for none. Refer to Planning Guide for specific grommet dimensions.</p> <p>Worksurface stiffeners are recommended to provide additional support for open spans greater than 48"w.</p>

# Worksurface 1 1/4"

## Bow front and support

Reff Profiles

description	w	d	h	pattern no.	L	M/V1	V2	V3
Bow shaped top	72"	30"		<b>RMB(A)7230-( ) ( )</b>	\$899.	\$1,015.	\$1,168.	\$1,576.
	84"	30"		<b>RMB(A)8430-( ) ( )</b>	990.	1,120.	1,286.	1,736.
	96"	30"		<b>RMB(A)9630-( ) ( )</b>	1,100.	1,241.	1,424.	1,925.

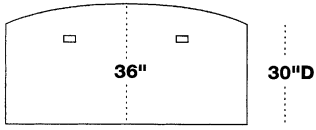

Use 29" deep pedestals or end panels.  
**Do not** use 23" deep pedestals if using recessed modesty.

Bow shaped top - 36"D	72"	36"		<b>RMB(A)7236-( ) ( )</b>	956.	1,077.	1,240.	1,673.
	84"	36"		<b>RMB(A)8436-( ) ( )</b>	1,048.	1,183.	1,360.	1,835.
	96"	36"		<b>RMB(A)9636-( ) ( )</b>	1,161.	1,311.	1,505.	2,032.

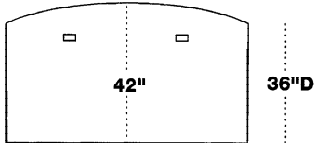





Use with 29" deep end panels or 29" deep pedestals (this will provide a cantilevered appearance).  
 Can also be used with 36" deep end panel and recessed modesty.

Order Code	Specification Information	Application Notes
Example: <b>RMBA7230R2</b>	<i>To order please specify pattern number including:</i>	<i>5. Finish type:</i>
<b>R</b> Reff	1. Top thickness	L = Laminate
<b>MB</b> Bowed front	2. Width	M = Wood/laminate mixed
<b>A</b> 1 1/4" thick	3. Depth	1 = V1
<b>72</b> 72" wide	4. Grommet option	2 = V2
<b>30</b> 30" wide	5. Top finish type	3 = V3
<b>R</b> Recessed grommet option	6. Top finish	Applicable finishes are listed on page 5 and 6.
<b>2</b> V2 finish	7. Grommet finish	Product on this page will accept woodgrain laminate where laminate is currently an option.
<b>V319</b> Medium cherry	<i>1. Thickness options:</i>	List price for woodgrain laminate options will be current published laminate list price plus 10%.
<b>111</b> Jet Black (grommet)	A = 1 1/4"	These worksurfaces are predrilled with metal inserts and use machine screws.
	<i>4. Grommet options:</i>	See Planning Guide for grommet locations.
	N = No grommet	Worksurface stiffeners are recommended to provide additional support for open spans greater than 48" w.
	F = Flush front grommet	
	R = Recessed grommet	
	A = Alternate location (only for 36" deep bow front tops)	
		*Bulkhead takes the place of a pedestal in applications using the short modesty panel, but not requiring a double pedestal application.
		<b>Knoll assumes no responsibility for special grommet locations which interfere with support or other hardware.</b>
		Actual widths of worksurface are 1/16" less than nominal dimension. Actual depth is 1/8" less than nominal dimension.
		Shipped with hardware. Refer to page 119 of Planning Guide for application details.

# Conference 1 1/4" Square and rectangular

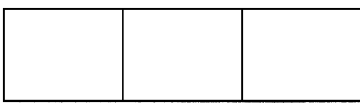
Reff Profiles

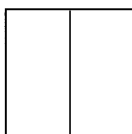
description	w	d	pattern no.	L	M/V1	V2	V3
Rectangular top 1 piece 	72"	30"	<b>RAA7230(-)</b>	\$580.	\$631.	\$725.	\$979.
	72"	36"	<b>RAA7236(-)</b>	630.	686.	788.	1,064.
	84"	30"	<b>RAA8430(-)</b>	642.	696.	802.	1,083.
	84"	36"	<b>RAA8436(-)</b>	690.	749.	860.	1,162.
	84"	42"	<b>RAA8442(-)</b>	1,019.	1,109.	1,272.	1,717.
	96"	30"	<b>RAA9630(-)</b>	720.	784.	900.	1,215.
	96"	36"	<b>RAA9636(-)</b>	794.	863.	994.	1,342.
	96"	42"	<b>RAA9642(-)</b>	1,170.	1,270.	1,461.	1,973.
Rectangular top 2 piece 	120"	36"	<b>RAA12036(-)</b>	1,275.	1,385.	1,594.	2,152.
	120"	42"	<b>RAA12042(-)</b>	1,758.	1,912.	2,199.	2,969.
	120"	48"	<b>RAA12048(-)</b>	1,911.	2,079.	2,389.	3,226.
	144"	42"	<b>RAA14442(-)</b>	1,976.	2,148.	2,470.	3,334.
	144"	48"	<b>RAA14448(-)</b>	2,116.	2,303.	2,648.	3,574.
Rectangular top 3 piece 	168"	42"	<b>RAA16842(-)</b>	2,589.	2,815.	3,240.	4,374.
	168"	48"	<b>RAA16848(-)</b>	2,814.	3,059.	3,518.	4,748.
	192"	42"	<b>RAA19242(-)</b>	2,808.	3,052.	3,508.	4,736.
	192"	48"	<b>RAA19248(-)</b>	3,023.	3,284.	3,775.	5,095.
Square tops  	*	60"	<b>RAA6060(-)</b>	1,188.	1,290.	1,487.	2,006.
	*	72"	<b>RAA7272(-)</b>	1,400.	1,523.	1,751.	2,365.
	-	36"	<b>RAA3636(-)</b>	447.	487.	561.	758.
	-	42"	<b>RAA4242(-)</b>	580.	631.	725.	979.
	-	48"	<b>RAA4848(-)</b>	763.	827.	952.	1,284.

Worksurfaces

Order Code	
Example: <b>RRAG72302</b>	
<b>R</b>	Reff
<b>R</b>	Rectangular
<b>A</b>	1 1/4" thick
<b>72</b>	72" wide
<b>30</b>	30" deep
<b>2</b>	V2 finish
<b>V319</b>	Medium cherry

**Specification Information**

To order please specify pattern number including:

1. Top thickness
2. Width
3. Depth
4. Finish type
5. Finish

1. Thickness options:  
A = 1 1/4"

4. Finish type:  
L = Laminate  
M = Wood/laminate mixed  
1 = V1  
2 = V2  
3 = V3

\*Square tops in two pieces.

**Application Notes**

Product on this page will accept woodgrain laminate where laminate is currently an option. List price for woodgrain laminate options will be current published laminate list price plus 10%.

All tops on this page are without grommets or drillings. The intended use of these products is to provide conference room table options.

Top to top brackets included.

Tops have no radius on edges that adjoin.

See table base matrix in Planning Guide, pages 140 and 141.

1 3/4" tops require support at mid point to reduce spans to 66" or less.

Mixed finish 1 3/4" tops are not post-formed.





Actual widths of worksurface are 1/16" less than nominal dimension. Actual depth is 1/8" less than nominal dimension.

Applicable finishes are listed on page 5 and 6.

Worksurface stiffeners are recommended to provide additional support for open spans greater than 48" w.

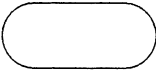
Conference 1 1/4"  
Round and racetrack

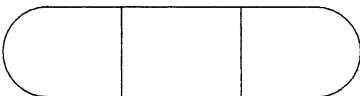
Reff Profiles

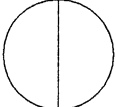
description	w	d	pattern no.	L, Option A	M/V!	V2	V3
Racetrack top 1 piece 	72"	30"	<b>RTA7230-()</b>	\$1,098.	\$1,193.	\$1,369.	\$1,850.
	84"	30"	<b>RTA8430-()</b>	1,221.	1,328.	1,527.	2,060.
	96"	30"	<b>RTA9630-()</b>	1,357.	1,478.	1,700.	2,294.
	72"	36"	<b>RTA7236-()</b>	1,252.	1,360.	1,563.	2,110.
	84"	36"	<b>RTA8436-()</b>	1,406.	1,530.	1,758.	2,372.
	96"	36"	<b>RTA9636-()</b>	1,560.	1,696.	1,952.	2,634.
	84"	42"	<b>RTA8442-()</b>	1,710.	1,861.	2,140.	2,889.
	96"	42"	<b>RTA9642-()</b>	1,917.	2,084.	2,395.	3,234.
	96"	48"	<b>RTA9648-()</b>	2,103.	2,283.	2,626.	3,544.
Racetrack top 2 piece 	120"	36"	<b>RTA12036-()</b>	2,014.	2,191.	2,521.	3,402.
	120"	42"	<b>RTA12042-()</b>	2,175.	2,361.	2,718.	3,669.
	144"	42"	<b>RTA14442-()</b>	2,398.	2,605.	2,996.	4,043.
	120"	48"	<b>RTA12048-()</b>	2,311.	2,512.	2,889.	3,900.
	144"	48"	<b>RTA14448-()</b>	2,457.	2,673.	3,071.	4,145.
Racetrack top 3 piece 	168"	42"	<b>RTA16842-()</b>	3,006.	3,266.	3,757.	5,072.
	192"	42"	<b>RTA19242-()</b>	3,228.	3,509.	4,038.	5,451.
	168"	48"	<b>RTA16848-()</b>	3,217.	3,494.	4,017.	5,425.
	192"	48"	<b>RTA19248-()</b>	3,361.	3,655.	4,201.	5,672.
Round tops  	-	36"	<b>RTA3636-()</b>	617.	671.	770.	1,040.
	-	42"	<b>RTA4242-()</b>	717.	776.	893.	1,205.
	-	48"	<b>RTA4848-()</b>	1,180.	1,281.	1,472.	1,987.
	*	60"	<b>RTA6060-()</b>	1,847.	2,008.	2,309.	3,117.
	*	72"	<b>RTA7272-()</b>	2,284.	2,483.	2,859.	3,860.

**Order Code**

Example: <b>RTA72302</b>	
<b>R</b>	Reff
<b>R</b>	Round
<b>A</b>	1 1/4" thick
<b>72</b>	72" wide
<b>30</b>	30" deep
<b>2</b>	V2 finish
<b>V319</b>	Medium cherry

**Specification Information**

To order please specify pattern number including:

1. Top thickness
2. Width
3. Depth
4. Finish type
5. Finish

1. Thickness options:

A = 1 1/4"

4. Finish type:

- L = Laminate
- M = Wood/laminate mixed
- 1 = V1
- 2 = V2
- 3 = V3

\*Round tops in two pieces.

**Application Notes**

Product on this page will accept woodgrain laminate where laminate is currently an option.

List price for woodgrain laminate options will be current published laminate list price plus 10%.

Top to top brackets included.

See table base matrix in Planning Guide pages 140 and 141.

Tops have no radius on edges that adjoin.

All tops on this page are without grommets or drillings. The intended use of these products is to provide conference room table options.

Actual widths of worksurface are 1/16" less than nominal dimension. Actual depth is 1/8" less than nominal dimension.

Applicable finishes are listed on page 5 and 6.

Worksurface stiffeners are recommended to provide additional support for open spans greater than 48"w.



Reff Profiles System incorporates optional worksurface edge details. Wood edges are crafted from select hardwoods and are finished with Knoll's industry leading polyurethane Reff Profiles Finish. Optional for worksurface tops listed on pages 0 through 0.

It is not necessary to plan separately for edges that "mate"; this feature is engineered into appropriate products when used as intended.

Edge detail to be specified by one of the following codes:

- A - Alpha
- B - Beta
- C - Chi
- D - Delta
- E - Epsilon
- F - Phi
- G - Gamma

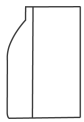

Alpha



Beta

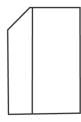

Chi



Delta



Epsilon



Phi

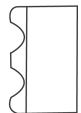

Gamma

Optional edge 1 1/4"  
front only, 20" and 24" deep

description	d	w	pattern no.	V1	V2	V3	
Straight rectangular work tops Profile edge front only 	20"	24"	RSA(A/B/C/D/E/F/G)F241-( )(1/2/3)	\$389.	\$444.	\$600.	
		30"	RSA(A/B/C/D/E/F/G)F301-( )(1/2/3)	426.	490.	661.	
		36"	RSA(A/B/C/D/E/F/G)F361-( )(1/2/3)	449.	517.	698.	
		42"	RSA(A/B/C/D/E/F/G)F421-( )(1/2/3)	470.	540.	729.	
		48"	RSA(A/B/C/D/E/F/G)F481-( )(1/2/3)	489.	561.	758.	
		54"	RSA(A/B/C/D/E/F/G)F541-( )(1/2/3)	507.	588.	793.	
		60"	RSA(A/B/C/D/E/F/G)F601-( )(1/2/3)	549.	632.	853.	
		66"	RSA(A/B/C/D/E/F/G)F661-( )(1/2/3)	565.	651.	878.	
		72"	RSA(A/B/C/D/E/F/G)F721-( )(1/2/3)	595.	685.	923.	
		78"	RSA(A/B/C/D/E/F/G)F781-( )(1/2/3)	603.	693.	935.	
		84"	RSA(A/B/C/D/E/F/G)F841-( )(1/2/3)	642.	737.	995.	
		90"	RSA(A/B/C/D/E/F/G)F901-( )(1/2/3)	667.	768.	1,037.	
		96"	RSA(A/B/C/D/E/F/G)F961-( )(1/2/3)	693.	798.	1,077.	
		24"	24"	RSA(A/B/C/D/E/F/G)F242-( )(1/2/3)	410.	470.	635.
			30"	RSA(A/B/C/D/E/F/G)F302-( )(1/2/3)	463.	532.	717.
			36"	RSA(A/B/C/D/E/F/G)F362-( )(1/2/3)	480.	552.	747.
			42"	RSA(A/B/C/D/E/F/G)F422-( )(1/2/3)	495.	568.	766.
			48"	RSA(A/B/C/D/E/F/G)F482-( )(1/2/3)	532.	609.	821.
			54"	RSA(A/B/C/D/E/F/G)F542-( )(1/2/3)	565.	651.	878.
60"	RSA(A/B/C/D/E/F/G)F602-( )(1/2/3)		606.	696.	940.		
66"	RSA(A/B/C/D/E/F/G)F662-( )(1/2/3)		629.	720.	973.		
72"	RSA(A/B/C/D/E/F/G)F722-( )(1/2/3)		655.	756.	1,019.		
78"	RSA(A/B/C/D/E/F/G)F782-( )(1/2/3)		688.	791.	1,068.		
84"	RSA(A/B/C/D/E/F/G)F842-( )(1/2/3)		714.	820.	1,109.		
90"	RSA(A/B/C/D/E/F/G)F902-( )(1/2/3)	745.	859.	1,158.			
96"	RSA(A/B/C/D/E/F/G)F962-( )(1/2/3)	774.	893.	1,205.			

Order Code	Specification Information	Application Notes
Example: <b>RSAGF241F2</b>	<i>To order please specify pattern number including:</i>	<b>Knoll assumes no responsibility for special grommet locations which interfere with support or other hardware. All requests for special grommet locations must be approved through custom product development.</b>
<b>R</b> Reff	5. Grommet options: N = No grommet F = Flush front grommet location R = Recessed front (not recommended on 20"D and 24"D tops)	
<b>S</b> Straight top	1. Edge profile	Products on this page are shipped without hardware which must be ordered separately from the support components section.
<b>A</b> 1 1/4" thick	2. F = Front edge with profile only	
<b>G</b> Gamma	3. Width	Product on this page will accept woodgrain laminate where laminate is currently an option. List price for woodgrain laminate options will be current published laminate list price plus 10%.
<b>F</b> Edge front only	4. Depth	
<b>24</b> 24" wide	5. Grommet option	Worksurface stiffeners are recommended to provide additional support for open spans greater than 48"w.
<b>1</b> 20" deep	6. Top finish type	
<b>F</b> Flush grommet	7. Top finish	
<b>2</b> V2 finish	8. Grommet finish	
<b>V319</b> Medium cherry	<i>1. Edge profile options:</i> A = Alpha B = Beta C = Chi D = Delta E = Epsilon F = Phi G = Gamma	
<b>111</b> Jet black (grommet)		
	Applicable finishes are listed on page 5 and 6.	
	Products on this page do not accept the following finishes: Y341 Wenge Y342 Medium Teak Y343 Dark Grey Oak	

Optional edge 1 1/4"  
front only, 30" and 36" deep

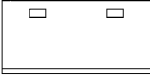
description	d	width	pattern no.	M/V1	V2	V3	
Straight rectangular work tops Profile edge front only 	30"	24"	RSA(A/B/C/D/E/F/G)F243-( )(1/2/3)	\$442.	\$510.	\$690.	
		30"	RSA(A/B/C/D/E/F/G)F303-( )(1/2/3)	500.	574.	774.	
		36"	RSA(A/B/C/D/E/F/G)F363-( )(1/2/3)	539.	617.	833.	
		42"	RSA(A/B/C/D/E/F/G)F423-( )(1/2/3)	560.	643.	868.	
		48"	RSA(A/B/C/D/E/F/G)F483-( )(1/2/3)	597.	690.	931.	
		54"	RSA(A/B/C/D/E/F/G)F543-( )(1/2/3)	647.	743.	1,001.	
		60"	RSA(A/B/C/D/E/F/G)F603-( )(1/2/3)	669.	769.	1,038.	
		66"	RSA(A/B/C/D/E/F/G)F663-( )(1/2/3)	686.	789.	1,065.	
		72"	RSA(A/B/C/D/E/F/G)F723-( )(1/2/3)	702.	805.	1,088.	
		78"	RSA(A/B/C/D/E/F/G)F783-( )(1/2/3)	735.	848.	1,144.	
		84"	RSA(A/B/C/D/E/F/G)F843-( )(1/2/3)	764.	880.	1,189.	
		90"	RSA(A/B/C/D/E/F/G)F903-( )(1/2/3)	799.	921.	1,244.	
		96"	RSA(A/B/C/D/E/F/G)F963-( )(1/2/3)	828.	954.	1,287.	
		36"	60"	RSA(A/B/C/D/E/F/G)F604-( )(1/2/3)	773.	889.	1,199.
			66"	RSA(A/B/C/D/E/F/G)F664-( )(1/2/3)	800.	923.	1,247.
			72"	RSA(A/B/C/D/E/F/G)F724-( )(1/2/3)	827.	953.	1,285.

Order Code	Specification Information	Application Notes
Example: <b>RSAGF243F2</b>	<i>To order please specify pattern number including:</i>	<p><b>Knoll assumes no responsibility for special grommet locations which interfere with support or other hardware. All requests for special grommet locations must be approved through custom product development.</b></p> <p>Products on this page are shipped without hardware which must be ordered separately from the support components section.</p> <p>Product on this page will accept woodgrain laminate where laminate is currently an option. List price for woodgrain laminate options will be current published laminate list price plus 10%.</p> <p>Worksurface stiffeners are recommended to provide additional support for open spans greater than 48"w.</p>
<b>R</b> Reff	1. Edge profile	
<b>S</b> Straight top	2. F = Front edge with profile only	
<b>A</b> 1 1/4" thick	3. Width	
<b>G</b> Gamma	4. Depth	
<b>F</b> Edge front only	5. Grommet option	
<b>24</b> 24" wide	6. Top finish type	
<b>3</b> 30" deep	7. Top finish	
<b>F</b> Flush grommet	8. Grommet finish	
<b>2</b> V2 finish	<i>1. Edge profile options:</i>	
<b>V319</b> Medium cherry	A = Alpha	
<b>111</b> Jet Black (grommet)	B = Beta	
	C = Chi	
	D = Delta	
	E = Epsilon	
	F = Phi	
	G = Gamma	
	5. Grommet options:	
	N = No grommet	
	F = Flush front grommet location	
	R = Recessed front	
	(not recommended on 20"D and 24"D tops)	
	6. Finish type:	
	M = Mixed (laminate surface / wood edge)	
	1 = V1	
	2 = V2	
	3 = V3	
	Applicable finishes are listed on page 5 and 6.	
	Products on this page do not accept the following finishes:	
	Y341 Wenge	
	Y342 Medium Teak	
	Y343 Dark Grey Oak	

Optional edge 1 1/4"  
front and back edge, 20" and 24" deep

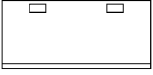
description	d	w	pattern no.	M/V1	V2	V3
Straight rectangular work tops Profile edge front and back only 	20"	24"	RSA(A/B/C/D/E/F/G)A241-( )(1/2/3)	\$389.	\$444.	\$600.
		30"	RSA(A/B/C/D/E/F/G)A301-( )(1/2/3)	426.	490.	661.
		36"	RSA(A/B/C/D/E/F/G)A361-( )(1/2/3)	449.	517.	698.
		42"	RSA(A/B/C/D/E/F/G)A421-( )(1/2/3)	470.	540.	729.
		48"	RSA(A/B/C/D/E/F/G)A481-( )(1/2/3)	489.	561.	758.
		54"	RSA(A/B/C/D/E/F/G)A541-( )(1/2/3)	507.	588.	793.
		60"	RSA(A/B/C/D/E/F/G)A601-( )(1/2/3)	549.	632.	853.
		66"	RSA(A/B/C/D/E/F/G)A661-( )(1/2/3)	565.	651.	878.
		72"	RSA(A/B/C/D/E/F/G)A721-( )(1/2/3)	595.	685.	923.
		78"	RSA(A/B/C/D/E/F/G)A781-( )(1/2/3)	603.	693.	935.
		84"	RSA(A/B/C/D/E/F/G)A841-( )(1/2/3)	642.	737.	995.
	90"	RSA(A/B/C/D/E/F/G)A901-( )(1/2/3)	667.	768.	1,037.	
	96"	RSA(A/B/C/D/E/F/G)A961-( )(1/2/3)	693.	798.	1,077.	
	24"	24"	RSA(A/B/C/D/E/F/G)A242-( )(1/2/3)	410.	470.	635.
		30"	RSA(A/B/C/D/E/F/G)A302-( )(1/2/3)	463.	532.	717.
		36"	RSA(A/B/C/D/E/F/G)A362-( )(1/2/3)	480.	552.	747.
		42"	RSA(A/B/C/D/E/F/G)A422-( )(1/2/3)	495.	568.	766.
		48"	RSA(A/B/C/D/E/F/G)A482-( )(1/2/3)	532.	609.	821.
		54"	RSA(A/B/C/D/E/F/G)A542-( )(1/2/3)	565.	651.	878.
		60"	RSA(A/B/C/D/E/F/G)A602-( )(1/2/3)	606.	696.	940.
		66"	RSA(A/B/C/D/E/F/G)A662-( )(1/2/3)	629.	720.	973.
72"		RSA(A/B/C/D/E/F/G)A722-( )(1/2/3)	655.	756.	1,019.	
78"		RSA(A/B/C/D/E/F/G)A782-( )(1/2/3)	688.	791.	1,068.	
84"	RSA(A/B/C/D/E/F/G)A842-( )(1/2/3)	714.	820.	1,109.		
90"	RSA(A/B/C/D/E/F/G)A902-( )(1/2/3)	745.	859.	1,158.		
96"	RSA(A/B/C/D/E/F/G)A962-( )(1/2/3)	774.	893.	1,205.		

Order Code	Specification Information	Application Notes
Example: <b>RSAGA241F2</b>	<i>To order please specify pattern number including:</i>	<b>Knoll assumes no responsibility for special grommet locations which interfere with support or other hardware. All requests for special grommet locations must be approved through custom product development.</b>
<b>R</b> Reff	1. Edge profile	Products on this page are shipped without hardware which must be ordered separately from the support components section.
<b>S</b> Straight top	2. 5th position A = Edge front and back	Product on this page will accept woodgrain laminate where laminate is currently an option.
<b>A</b> 1 1/4" thick	3. Width	List price for woodgrain laminate options will be current published laminate list price plus 10%.
<b>G</b> Gamma	4. Depth	Worksurface stiffeners are recommended to provide additional support for open spans greater than 48"w.
<b>A</b> Edge front and back	5. Grommet option	
<b>24</b> 24" wide	6. Top finish type	
<b>1</b> 20" deep	7. Top finish	
<b>F</b> Flush grommet	8. Grommet finish	
<b>2</b> V2 finish	<i>1. Edge profile options:</i>	
<b>V319</b> Medium cherry	A = Alpha	
<b>111</b> Jet Black (grommet)	B = Beta	
	C = Chi	
	D = Delta	
	E = Epsilon	
	F = Phi	
	G = Gamma	
	5. Grommet options:	
	N = No grommet	
	F = Flush front grommet location	
	R = Recessed front	
	(not recommended on 20"D and 24"D tops)	
	6. Finish type:	
	M = Mixed (laminate surface / wood edge)	
	1 = V1	
	2 = V2	
	3 = V3	
	Applicable finishes are listed on page 5 and 6.	
	Products on this page do not accept the following finishes:	
	Y341 Wenge	
	Y342 Medium Teak	
	Y343 Dark Grey Oak	

Optional edge 1 1/4"  
front and back edge, 30" and 36" deep

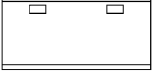
description	d	w	pattern no.	V1	V2	V3
Straight rectangular work tops Profile edge front and back only 	30"	24"	RSA(A/B/C/D/E/F/G)A243-( )(1/2/3)	\$442.	\$510.	\$690.
		30"	RSA(A/B/C/D/E/F/G)A303-( )(1/2/3)	500.	574.	774.
		36"	RSA(A/B/C/D/E/F/G)A363-( )(1/2/3)	539.	617.	833.
		42"	RSA(A/B/C/D/E/F/G)A423-( )(1/2/3)	560.	643.	868.
		48"	RSA(A/B/C/D/E/F/G)A483-( )(1/2/3)	597.	690.	931.
		54"	RSA(A/B/C/D/E/F/G)A543-( )(1/2/3)	647.	743.	1,001.
		60"	RSA(A/B/C/D/E/F/G)A603-( )(1/2/3)	669.	769.	1,038.
		66"	RSA(A/B/C/D/E/F/G)A663-( )(1/2/3)	686.	789.	1,065.
		72"	RSA(A/B/C/D/E/F/G)A723-( )(1/2/3)	702.	805.	1,088.
		78"	RSA(A/B/C/D/E/F/G)A783-( )(1/2/3)	735.	848.	1,144.
		84"	RSA(A/B/C/D/E/F/G)A843-( )(1/2/3)	764.	880.	1,189.
		90"	RSA(A/B/C/D/E/F/G)A903-( )(1/2/3)	799.	921.	1,244.
		96"	RSA(A/B/C/D/E/F/G)A963-( )(1/2/3)	828.	954.	1,287.
36"	60"	RSA(A/B/C/D/E/F/G)A604-( )(1/2/3)	773.	889.	1,199.	
	66"	RSA(A/B/C/D/E/F/G)A664-( )(1/2/3)	800.	923.	1,247.	
	72"	RSA(A/B/C/D/E/F/G)A724-( )(1/2/3)	827.	953.	1,285.	

Worksurfaces

Order Code	Specification Information	Application Notes
Example: <b>RSAGA243F2</b>	<i>}&gt;To order please specify pattern number including:</i>	<p><b>Knoll assumes no responsibility for special grommet locations which interfere with support or other hardware. All requests for special grommet locations must be approved through custom product development.</b></p> <p>Products on this page are shipped without hardware which must be ordered separately from the support components section.</p> <p>Product on this page will accept woodgrain laminate where laminate is currently an option. List price for woodgrain laminate options will be current published laminate list price plus 10%.</p> <p>Worksurface stiffeners are recommended to provide additional support for open spans greater than 48" w.</p>
<b>R</b> Reff	1. Edge profile	
<b>S</b> Straight top	2. 5th position A = Edge front and back	
<b>A</b> 1 1/4" thick	3. Width	
<b>G</b> Gamma	4. Depth	
<b>A</b> Edge front and back	5. Grommet option	
<b>24</b> 24" wide	6. Top finish type	
<b>3</b> 30" deep	7. Top finish	
<b>F</b> Flush grommet	8. Grommet finish	
<b>2</b> V2 finish	<i>1. Edge profile options:</i>	
<b>V319</b> Medium cherry	A = Alpha	
<b>111</b> Jet Black (grommet)	B = Beta	
	C = Chi	
	D = Delta	
	E = Epsilon	
	F = Phi	
	G = Gamma	
	5. Grommet options: N = No grommet F = Flush front grommet location R = Recessed front (not recommended on 20"D and 24"D tops)	
	6. Finish type: M = Mixed (laminate surface / wood edge) 1 = V1 2 = V2 3 = V3	
	Applicable finishes are listed on page 5 and 6.	
	Products on this page do not accept the following finishes: Y341 Wenge Y342 Medium Teak Y343 Dark Grey Oak	

# Optional edge 1 1/4" front and attaching edge profiled

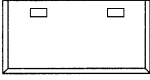
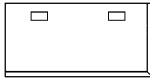
description	d	w	pattern no.	V1	V2	V3
Bridge work tops, Profile edge front only, Accepts Same Edge on attaching sides 	20"	24"	RSA(A/B/C/D/E/F/G)B241-( )(1/2/3)	\$389.	\$444.	\$600.
		30"	RSA(A/B/C/D/E/F/G)B301-( )(1/2/3)	426.	490.	661.
		36"	RSA(A/B/C/D/E/F/G)B361-( )(1/2/3)	449.	517.	698.
		42"	RSA(A/B/C/D/E/F/G)B421-( )(1/2/3)	470.	540.	729.
		48"	RSA(A/B/C/D/E/F/G)B481-( )(1/2/3)	489.	561.	758.
	24"	24"	RSA(A/B/C/D/E/F/G)B242-( )(1/2/3)	410.	470.	635.
		30"	RSA(A/B/C/D/E/F/G)B302-( )(1/2/3)	463.	532.	717.
		36"	RSA(A/B/C/D/E/F/G)B362-( )(1/2/3)	480.	552.	747.
		42"	RSA(A/B/C/D/E/F/G)B422-( )(1/2/3)	495.	568.	766.
		48"	RSA(A/B/C/D/E/F/G)B482-( )(1/2/3)	532.	609.	821.
Left-hand return work tops, Profile edge front only, Accepts Same Edge on attaching side 	20"	24"	RSA(A/B/C/D/E/F/G)L241-( )(1/2/3)	389.	444.	600.
		30"	RSA(A/B/C/D/E/F/G)L301-( )(1/2/3)	426.	490.	661.
		36"	RSA(A/B/C/D/E/F/G)L361-( )(1/2/3)	449.	517.	698.
		42"	RSA(A/B/C/D/E/F/G)L421-( )(1/2/3)	470.	540.	729.
		48"	RSA(A/B/C/D/E/F/G)L481-( )(1/2/3)	489.	561.	758.
	24"	24"	RSA(A/B/C/D/E/F/G)L242-( )(1/2/3)	410.	470.	635.
		30"	RSA(A/B/C/D/E/F/G)L302-( )(1/2/3)	463.	532.	717.
		36"	RSA(A/B/C/D/E/F/G)L362-( )(1/2/3)	480.	552.	747.
		42"	RSA(A/B/C/D/E/F/G)L422-( )(1/2/3)	495.	568.	766.
		48"	RSA(A/B/C/D/E/F/G)L482-( )(1/2/3)	532.	609.	821.

Order Code	Specification Information	Application Notes
Example: <b>RSAGB241F2</b>	<i>To order please specify pattern number including:</i>	<p><b>Knoll assumes no responsibility for special grommet locations which interfere with support or other hardware. All requests for special grommet locations must be approved through custom product development.</b></p> <p>Products on this page are shipped without hardware which must be ordered separately from the support components section.</p> <p>Product on this page will accept woodgrain laminate where laminate is currently an option. List price for woodgrain laminate options will be current published laminate list price plus 10%.</p> <p>Worksurface stiffeners are recommended to provide additional support for open spans greater than 48" w.</p> <p>Applicable finishes are listed on page 5 and 6.</p> <p>Products on this page do not accept the following finishes: Y341 Wenge Y342 Medium Teak Y343 Dark Grey Oak</p> <p>Return/mating edges indicated above and are the reverse profile of the primary edge profile selected. Double line reflected in images above along depth of top indicates where mating profile is applied, double line along width/front edge indicates primary edge of profile selected.</p>
<b>R</b> Reff	1. Edge profile	
<b>S</b> Straight top	2. 5th position indicates how and which edges profiled	
<b>A</b> 1 1/4" thick	3. Width	
<b>G</b> Gamma	4. Depth	
<b>B</b> Both ends accept edge	5. Grommet option	
<b>24</b> 24" wide	6. Top finish type	
<b>1</b> 20" deep	7. Top finish	
<b>F</b> Flush grommet	8. Grommet finish	
<b>2</b> V2 finish	<i>1. Edge profile options:</i>	
<b>V319</b> Medium cherry	A = Alpha	
<b>111</b> Jet Black (grommet)	B = Beta	
	C = Chi	
	D = Delta	
	E = Epsilon	
	F = Phi	
	G = Gamma	
	<i>2. 5th position options:</i>	
	B = Front edge primary profile and both sides reverse profile for mating (bridge)	
	L = Left hand return, front edge primary profile, right edge reverse profile for mating	
	R = Right hand return, front edge primary profile, left edge reverse profile for mating	
	<i>5. Grommet options:</i>	
	N = No grommet	
	F = Flush front grommet location	
	R = Recessed front (not recommended on 20"D and 24"D tops)	
	<i>6. Finish type:</i>	
	M = Mixed (laminated surface / wood edge)	
	1 = V1	
	2 = V2	
	3 = V3	

# Optional edge 1 1/4" front and attaching edge profiled

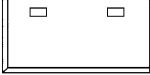
description	d	w	pattern no.	V1	V2	V3
Right-hand return work tops, Profile edge front only, Accepts Same Edge on attaching side 	20"	24"	<b>RSA(A/B/C/D/E/F/G)R241-( )(1/2/3)</b>	\$389.	\$444.	\$600.
		30"	<b>RSA(A/B/C/D/E/F/G)R301-( )(1/2/3)</b>	426.	490.	661.
		36"	<b>RSA(A/B/C/D/E/F/G)R361-( )(1/2/3)</b>	449.	517.	698.
		42"	<b>RSA(A/B/C/D/E/F/G)R421-( )(1/2/3)</b>	470.	540.	729.
		48"	<b>RSA(A/B/C/D/E/F/G)R481-( )(1/2/3)</b>	489.	561.	758.
	24"	24"	<b>RSA(A/B/C/D/E/F/G)R242-( )(1/2/3)</b>	410.	470.	635.
		30"	<b>RSA(A/B/C/D/E/F/G)R302-( )(1/2/3)</b>	463.	532.	717.
		36"	<b>RSA(A/B/C/D/E/F/G)R362-( )(1/2/3)</b>	480.	552.	747.
		42"	<b>RSA(A/B/C/D/E/F/G)R422-( )(1/2/3)</b>	495.	568.	766.
		48"	<b>RSA(A/B/C/D/E/F/G)R482-( )(1/2/3)</b>	532.	609.	821.

Order Code	Specification Information	Application Notes
Example: <b>RSAGB241F2</b>	<i>To order please specify pattern number including:</i>	<b>Knoll assumes no responsibility for special grommet locations which interfere with support or other hardware. All requests for special grommet locations must be approved through custom product development.</b>
<b>R</b> Reff	2. 5th position options: B = Front edge primary profile and both sides reverse profile for mating (bridge) L = Left hand return, front edge primary profile, right edge reverse profile for mating R = Right hand return, front edge primary profile, left edge reverse profile for mating	
<b>S</b> Straight top	1. Edge profile	Products on this page are shipped without hardware which must be ordered separately from the support components section.
<b>A</b> 1 1/4" thick	2. 5th position indicates how and which edges profiled	
<b>G</b> Gamma	3. Width	Product on this page will accept woodgrain laminate where laminate is currently an option. List price for woodgrain laminate options will be current published laminate list price plus 10%.
<b>B</b> Both ends accept edge	4. Depth	
<b>24</b> 24" wide	5. Grommet option	Worksurface stiffeners are recommended to provide additional support for open spans greater than 48" w.
<b>1</b> 20" deep	6. Top finish type	
<b>F</b> Flush grommet	7. Top finish	Applicable finishes are listed on page 5 and 6.
<b>2</b> V2 finish	8. Grommet finish	
<b>V319</b> Medium cherry	<i>1. Edge profile options:</i> A = Alpha B = Beta C = Chi D = Delta E = Epsilon F = Phi G = Gamma	Products on this page do not accept the following finishes: Y341 Wenge Y342 Medium Teak Y343 Dark Grey Oak
<b>111</b> Jet Black (grommet)	<i>2. 5th position options:</i> N = No grommet F = Flush front grommet location R = Recessed front (not recommended on 20"D and 24"D tops)	
	<i>3. Width</i>	Return/mating edges indicated above and are the reverse profile of the primary edge profile selected. Double line reflected in images above along depth of top indicates where mating profile is applied, double line along width/front edge indicates primary edge of profile selected.
	<i>4. Depth</i>	
	<i>5. Grommet options:</i> N = No grommet F = Flush front grommet location R = Recessed front (not recommended on 20"D and 24"D tops)	
	<i>6. Finish type:</i> M = Mixed (laminated surface / wood edge) 1 = V1 2 = V2 3 = V3	

# Optional edge 1 1/4" curvilinear corner front edge only

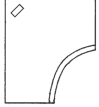
description	width1	w right	pattern no.	M/V1	V2	V3
Curved corner work tops with Profile edge on front only, return depth left and right 20" 	36"	36"	RCA(A/B/C/D/E/F/G)F363611-( )(1/2/3)	\$822.	\$945.	\$1,276.
	36"	42"	RCA(A/B/C/D/E/F/G)F423611-( )(1/2/3)	869.	1,000.	1,350.
	36"	48"	RCA(A/B/C/D/E/F/G)F483611-( )(1/2/3)	925.	1,062.	1,434.
	42"	36"	RCA(A/B/C/D/E/F/G)F364211-( )(1/2/3)	869.	1,000.	1,350.
	42"	42"	RCA(A/B/C/D/E/F/G)F424211-( )(1/2/3)	925.	1,062.	1,434.
	42"	48"	RCA(A/B/C/D/E/F/G)F484211-( )(1/2/3)	1,010.	1,160.	1,566.
	48"	36"	RCA(A/B/C/D/E/F/G)F364811-( )(1/2/3)	925.	1,062.	1,434.
	48"	42"	RCA(A/B/C/D/E/F/G)F424811-( )(1/2/3)	1,010.	1,160.	1,566.
	48"	48"	RCA(A/B/C/D/E/F/G)F484811-( )(1/2/3)	1,062.	1,222.	1,649.
Curved corner work tops with Profile edge on front only, left return depth 20", right return depth 24"	36"	36"	RCA(A/B/C/D/E/F/G)F363612-( )(1/2/3)	859.	987.	1,334.
	36"	42"	RCA(A/B/C/D/E/F/G)F423612-( )(1/2/3)	905.	1,041.	1,406.
	36"	48"	RCA(A/B/C/D/E/F/G)F483612-( )(1/2/3)	962.	1,103.	1,491.
	42"	36"	RCA(A/B/C/D/E/F/G)F364212-( )(1/2/3)	905.	1,041.	1,406.
	42"	42"	RCA(A/B/C/D/E/F/G)F424212-( )(1/2/3)	962.	1,103.	1,491.
	42"	48"	RCA(A/B/C/D/E/F/G)F484212-( )(1/2/3)	1,047.	1,202.	1,624.
	48"	36"	RCA(A/B/C/D/E/F/G)F364812-( )(1/2/3)	962.	1,103.	1,491.
	48"	42"	RCA(A/B/C/D/E/F/G)F424812-( )(1/2/3)	1,047.	1,202.	1,624.
	48"	48"	RCA(A/B/C/D/E/F/G)F484812-( )(1/2/3)	1,099.	1,265.	1,708.
Curved corner work tops with Profile edge on front only, left return 24", right return 20"	36"	36"	RCA(A/B/C/D/E/F/G)F363621-( )(1/2/3)	859.	987.	1,334.
	36"	42"	RCA(A/B/C/D/E/F/G)F423621-( )(1/2/3)	905.	1,041.	1,406.
	36"	48"	RCA(A/B/C/D/E/F/G)F483621-( )(1/2/3)	962.	1,103.	1,491.
	42"	36"	RCA(A/B/C/D/E/F/G)F364221-( )(1/2/3)	905.	1,041.	1,406.
	42"	42"	RCA(A/B/C/D/E/F/G)F424221-( )(1/2/3)	962.	1,103.	1,491.
	42"	48"	RCA(A/B/C/D/E/F/G)F484221-( )(1/2/3)	1,047.	1,202.	1,624.
	48"	36"	RCA(A/B/C/D/E/F/G)F364821-( )(1/2/3)	962.	1,103.	1,491.
	48"	42"	RCA(A/B/C/D/E/F/G)F424821-( )(1/2/3)	1,047.	1,202.	1,624.
	48"	48"	RCA(A/B/C/D/E/F/G)F484821-( )(1/2/3)	1,099.	1,265.	1,708.
Curved corner work tops with Profile edge on front only, return depth left and right 24"	36"	36"	RCA(A/B/C/D/E/F/G)F363622-( )(1/2/3)	932.	1,072.	1,448.
	36"	42"	RCA(A/B/C/D/E/F/G)F423622-( )(1/2/3)	982.	1,126.	1,520.
	36"	48"	RCA(A/B/C/D/E/F/G)F483622-( )(1/2/3)	1,034.	1,188.	1,605.
	42"	36"	RCA(A/B/C/D/E/F/G)F364222-( )(1/2/3)	982.	1,126.	1,520.
	42"	42"	RCA(A/B/C/D/E/F/G)F424222-( )(1/2/3)	1,034.	1,188.	1,605.

Order Code	Specification Information	Application Notes
Example: <b>RCAGF363611</b>	<i>To order please specify pattern number including:</i>	<b>Knoll assumes no responsibility for special grommet locations which interfere with support or other hardware. All requests for special grommet locations must be approved through custom product development.</b>  Products on this page are shipped without hardware which must be ordered separately from the support components section.  Product on this page will accept woodgrain laminate where laminate is currently an option. List price for woodgrain laminate options will be current published laminate list price plus 10%.  Worksurface stiffeners recommended to provide additional support for open spans greater than 48"w.
<b>R</b> Reff	1. Edge profile	
<b>C</b> Corner top	2. Left hand width	
<b>A</b> 1 1/4" thick	3. Right hand width	
<b>G</b> Gamma	4. Return left hand depth	
<b>F</b> Edge Front only	5. Return right hand depth	
<b>36</b> 36" wide	6. Grommet option	
<b>36</b> 36" wide	7. Top finish type	
<b>1</b> 20" deep	8. Top finish	
<b>1</b> 20" deep	9. Grommet finish	
<b>F</b> Flush grommet	<i>1. Edge profile options:</i>	
<b>2</b> V2 finish	A = Alpha	
<b>V319</b> Medium cherry	B = Beta	
<b>111</b> Jet Black (grommet)	C = Chi	
	D = Delta	
	E = Epsilon	
	F = Phi	
	G = Gamma	
	6. Grommet options: N = No grommet F = Flush front grommet location	
	7. Finish type: M = Mixed (laminated surface / wood edge) 1 = V1 2 = V2 3 = V3	
	Applicable finishes are listed on page 5 and 6.	
	Products on this page do not accept the following finishes: Y341 Wenge Y342 Medium Teak Y343 Dark Grey Oak	







# Optional edge 1 1/4" curvilinear corner front edge only

description	widthl	w right	pattern no.	M/V1	V2	V3
Curved corner work tops with Profile edge on front only, return depth left and right 24"	42"	48"	RCA(A/B/C/D/E/F/G)F484222-( )(1/2/3)	\$1,121.	\$1,289.	\$1,740.
	48"	36"	RCA(A/B/C/D/E/F/G)F364822-( )(1/2/3)	1,034.	1,188.	1,605.
	48"	42"	RCA(A/B/C/D/E/F/G)F424822-( )(1/2/3)	1,121.	1,289.	1,740.
	48"	48"	RCA(A/B/C/D/E/F/G)F484822-( )(1/2/3)	1,174.	1,348.	1,820.

Order Code	Specification Information	Application Notes
Example: <b>RCAGF363611</b>	<i>To order please specify pattern number including:</i>	
<b>R</b> Reff	1. Edge profile	<b>Knoll assumes no responsibility for special grommet locations which interfere with support or other hardware. All requests for special grommet locations must be approved through custom product development.</b>
<b>C</b> Corner top	2. Left hand width	Products on this page are shipped without hardware which must be ordered separately from the support components section.
<b>A</b> 1 1/4" thick	3. Right hand width	Product on this page will accept woodgrain laminate where laminate is currently an option.
<b>G</b> Gamma	4. Return left hand depth	List price for woodgrain laminate options will be current published laminate list price plus 10%.
<b>F</b> Edge Front only	5. Return right hand depth	Worksurface stiffeners recommended to provide additional support for open spans greater than 48"w.
<b>36</b> 36" wide	6. Grommet option	
<b>36</b> 36" wide	7. Top finish type	
<b>1</b> 20" deep	8. Top finish	
<b>1</b> 20" deep	9. Grommet finish	
<b>F</b> Flush grommet	<i>1. Edge profile options:</i>	
<b>2</b> V2 finish	A = Alpha	
<b>V319</b> Medium cherry	B = Beta	
<b>111</b> Jet Black (grommet)	C = Chi	
	D = Delta	
	E = Epsilon	
	F = Phi	
	G = Gamma	
	<i>6. Grommet options:</i>	
	N = No grommet	
	F = Flush front grommet location	
	<i>7. Finish type:</i>	
	M = Mixed (laminata surface / wood edge)	
	1 = V1	
	2 = V2	
	3 = V3	
	Applicable finishes are listed on page 5 and 6.	
	Products on this page do not accept the following finishes:	
	Y341 Wenge	
	Y342 Medium Teak	
	Y343 Dark Grey Oak	

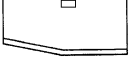
Optional edge 1 1/4"  
wave end tops  
front edge only

description	depth1	d right	w	pattern no.	M/V1	V2	V3
Wave transition top with profile edge front only (left 24", right 20") 	20"	24"	42"	<b>RWA(A/B/C/D/E/F/G)F4221-( ) (1/2/3)</b>	\$496.	\$571.	\$770.
	20"	24"	48"	<b>RWA(A/B/C/D/E/F/G)F4821-( ) (1/2/3)</b>	521.	600.	810.
	20"	24"	54"	<b>RWA(A/B/C/D/E/F/G)F5421-( ) (1/2/3)</b>	557.	642.	866.
	20"	24"	60"	<b>RWA(A/B/C/D/E/F/G)F6021-( ) (1/2/3)</b>	596.	688.	927.
	20"	24"	66"	<b>RWA(A/B/C/D/E/F/G)F6621-( ) (1/2/3)</b>	615.	706.	956.
	20"	24"	72"	<b>RWA(A/B/C/D/E/F/G)F7221-( ) (1/2/3)</b>	643.	741.	999.
Wave transition top with profile edge front only (left 30", right 24") 	24"	30"	42"	<b>RWA(A/B/C/D/E/F/G)F4232-( ) (1/2/3)</b>	537.	615.	829.
	24"	30"	48"	<b>RWA(A/B/C/D/E/F/G)F4832-( ) (1/2/3)</b>	556.	639.	862.
	24"	30"	54"	<b>RWA(A/B/C/D/E/F/G)F5432-( ) (1/2/3)</b>	600.	691.	932.
	24"	30"	60"	<b>RWA(A/B/C/D/E/F/G)F6032-( ) (1/2/3)</b>	642.	737.	995.
	24"	30"	66"	<b>RWA(A/B/C/D/E/F/G)F6632-( ) (1/2/3)</b>	664.	765.	1,033.
	24"	30"	72"	<b>RWA(A/B/C/D/E/F/G)F7232-( ) (1/2/3)</b>	700.	803.	1,085.
Wave transition top with profile edge front only (left 20", right 24") 	24"	20"	42"	<b>RWA(A/B/C/D/E/F/G)F4212-( ) (1/2/3)</b>	496.	571.	770.
	24"	20"	48"	<b>RWA(A/B/C/D/E/F/G)F4812-( ) (1/2/3)</b>	521.	600.	810.
	24"	20"	54"	<b>RWA(A/B/C/D/E/F/G)F5412-( ) (1/2/3)</b>	557.	642.	866.
	24"	20"	60"	<b>RWA(A/B/C/D/E/F/G)F6012-( ) (1/2/3)</b>	596.	688.	927.
	24"	20"	66"	<b>RWA(A/B/C/D/E/F/G)F6612-( ) (1/2/3)</b>	615.	706.	956.
	24"	20"	72"	<b>RWA(A/B/C/D/E/F/G)F7212-( ) (1/2/3)</b>	643.	741.	999.
Wave transition top with profile edge front only (left 24", right 30") 	30"	24"	42"	<b>RWA(A/B/C/D/E/F/G)F4223-( ) (1/2/3)</b>	537.	615.	829.
	30"	24"	48"	<b>RWA(A/B/C/D/E/F/G)F4823-( ) (1/2/3)</b>	556.	639.	862.
	30"	24"	54"	<b>RWA(A/B/C/D/E/F/G)F5423-( ) (1/2/3)</b>	600.	691.	932.
	30"	24"	60"	<b>RWA(A/B/C/D/E/F/G)F6023-( ) (1/2/3)</b>	642.	737.	995.
	30"	24"	66"	<b>RWA(A/B/C/D/E/F/G)F6623-( ) (1/2/3)</b>	664.	765.	1,033.
	30"	24"	72"	<b>RWA(A/B/C/D/E/F/G)F7223-( ) (1/2/3)</b>	700.	803.	1,085.
Wave end top with profile edge front only (20" right) 	20"	32"	36"	<b>RWEA(A/B/C/D/E/F/G)F3631-( ) (1/2/3)</b>	659.	759.	1,024.
	20"	32"	42"	<b>RWEA(A/B/C/D/E/F/G)F4231-( ) (1/2/3)</b>	686.	789.	1,065.
	20"	32"	48"	<b>RWEA(A/B/C/D/E/F/G)F4831-( ) (1/2/3)</b>	721.	829.	1,121.

Order Code	Specification Information	Application Notes
Example: <b>RWAGF422-1F2</b>	<i>To order please specify pattern number including:</i>	<p><b>Knoll assumes no responsibility for special grommet locations which interfere with support or other hardware. All requests for special grommet locations must be approved through custom product development.</b></p> <p>Products on this page are shipped without hardware which must be ordered separately from the support components section.</p> <p>Product on this page will accept woodgrain laminate where laminate is currently an option.</p> <p>List price for woodgrain laminate options will be current published laminate list price plus 10%.</p> <p>Worksurface stiffeners are recommended to provide additional support for open spans greater than 48" w.</p>
<b>R</b> Reff	1. Edge profile	
<b>W</b> Wave transition top	2. 5th position F = front edge with profile only	
<b>A</b> 1 1/4" thick	3. Width	
<b>G</b> Gamma	4. Left hand depth	
<b>F</b> Edge front only	5. Right hand depth	
<b>42</b> 42" wide	6. Grommet option	
<b>2</b> 20" deep	7. Top finish type	
<b>1</b> 20" deep	8. Top finish	
<b>F</b> Flush grommet	9. Grommet finish	
<b>2</b> V2 finish	<i>1. Edge profile options:</i>	
<b>V319</b> Medium cherry	A = Alpha	
<b>111</b> Jet Black (grommet)	B = Beta	
	C = Chi	
	D = Delta	
	E = Epsilon	
	F = Phi	
	G = Gamma	
	<i>6. Grommet options:</i>	
	N = No grommet	
	F = Flush front grommet location	
	<i>7. Finish type:</i>	
	M = Mixed (laminate surface / wood edge)	
	1 = V1	
	2 = V2	
	3 = V3	
	Applicable finishes are listed on page 5 and 6.	
	Products on this page do not accept the following finishes:	
	Y341 Wenge	
	Y342 Medium Teak	
	Y343 Dark Grey Oak	

Optional edge 1 1/4"  
wave end tops  
front edge only

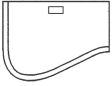
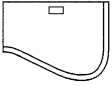
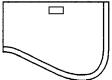
description	depthl	d right	w	pattern no.	M/V1	V2	V3
Wave end top with profile edge front only (24" right) 	24"	36"	36"	RWEA(A/B/C/D/E/F/G)F3662-( )(1/2/3)	\$683.	\$785.	\$1,059.
	24"	36"	42"	RWEA(A/B/C/D/E/F/G)F4262-( )(1/2/3)	703.	808.	1,091.
	24"	36"	48"	RWEA(A/B/C/D/E/F/G)F4862-( )(1/2/3)	744.	858.	1,157.
Wave end top with profile edge front only (20" left) 	32"	20"	36"	RWEA(A/B/C/D/E/F/G)F3613-( )(1/2/3)	659.	759.	1,024.
	32"	20"	42"	RWEA(A/B/C/D/E/F/G)F4213-( )(1/2/3)	686.	789.	1,065.
	32"	20"	48"	RWEA(A/B/C/D/E/F/G)F4813-( )(1/2/3)	721.	829.	1,121.
Wave end top with profile edge front only (24" left) 	36"	24"	36"	RWEA(A/B/C/D/E/F/G)F3626-( )(1/2/3)	683.	785.	1,059.
	36"	24"	42"	RWEA(A/B/C/D/E/F/G)F4226-( )(1/2/3)	703.	808.	1,091.
	36"	24"	48"	RWEA(A/B/C/D/E/F/G)F4826-( )(1/2/3)	744.	858.	1,157.

Order Code	Specification Information	Application Notes
Example: <b>RWAGF422-1F2</b>	<i>To order please specify pattern number including:</i>	<b>Knoll assumes no responsibility for special grommet locations which interfere with support or other hardware. All requests for special grommet locations must be approved through custom product development.</b>
<b>R</b> Reff	6. Grommet options: N = No grommet F = Flush front grommet location	
<b>W</b> Wave transition top	1. Edge profile	Products on this page are shipped without hardware which must be ordered separately from the support components section.
<b>A</b> 1 1/4" thick	2. 5th position F = front edge with profile only	
<b>G</b> Gamma	3. Width	Product on this page will accept woodgrain laminate where laminate is currently an option.
<b>F</b> Edge front only	4. Left hand depth	
<b>42</b> 42" wide	5. Right hand depth	List price for woodgrain laminate options will be current published laminate list price plus 10%.
<b>2</b> 20" deep	6. Grommet option	
<b>1</b> 20" deep	7. Top finish type	Worksurface stiffeners are recommended to provide additional support for open spans greater than 48"w.
<b>F</b> Flush grommet	8. Top finish	
<b>2</b> V2 finish	9. Grommet finish	
<b>V319</b> Medium cherry	<i>1. Edge profile options:</i> A = Alpha B = Beta C = Chi D = Delta E = Epsilon F = Phi G = Gamma	
<b>111</b> Jet Black (grommet)		

# Optional edge 1 1/4" meeting tops



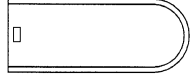

description	d	w	pattern no.	V1	V2	V3
Peninsula D-shaped tops Profile edge on all except flat side. <b>Grommet choices are centered (as shown) or none</b>	30"	42"	<b>RMDA(A/B/C/D/E/F/G)F4230-( )(1/2/3)</b>	\$701.	\$804.	\$1,086.
	30"	48"	<b>RMDA(A/B/C/D/E/F/G)F4830-( )(1/2/3)</b>	758.	868.	1,172.
	30"	54"	<b>RMDA(A/B/C/D/E/F/G)F5430-( )(1/2/3)</b>	810.	932.	1,258.
	30"	60"	<b>RMDA(A/B/C/D/E/F/G)F6030-( )(1/2/3)</b>	866.	995.	1,343.
	30"	66"	<b>RMDA(A/B/C/D/E/F/G)F6630-( )(1/2/3)</b>	924.	1,061.	1,433.
	30"	72"	<b>RMDA(A/B/C/D/E/F/G)F7230-( )(1/2/3)</b>	981.	1,125.	1,519.
	30"	78"	<b>RMDA(A/B/C/D/E/F/G)F7830-( )(1/2/3)</b>	1,108.	1,273.	1,719.
	30"	84"	<b>RMDA(A/B/C/D/E/F/G)F8430-( )(1/2/3)</b>	1,237.	1,421.	1,919.
	30"	90"	<b>RMDA(A/B/C/D/E/F/G)F9030-( )(1/2/3)</b>	1,382.	1,588.	2,143.
	30"	96"	<b>RMDA(A/B/C/D/E/F/G)F9630-( )(1/2/3)</b>	1,523.	1,751.	2,365.
	36"	42"	<b>RMDA(A/B/C/D/E/F/G)F4236-( )(1/2/3)</b>	771.	887.	1,197.
	36"	48"	<b>RMDA(A/B/C/D/E/F/G)F4836-( )(1/2/3)</b>	843.	970.	1,310.
	36"	54"	<b>RMDA(A/B/C/D/E/F/G)F5436-( )(1/2/3)</b>	964.	1,111.	1,498.
	36"	60"	<b>RMDA(A/B/C/D/E/F/G)F6036-( )(1/2/3)</b>	1,082.	1,245.	1,681.
	36"	66"	<b>RMDA(A/B/C/D/E/F/G)F6636-( )(1/2/3)</b>	1,101.	1,268.	1,712.
	36"	72"	<b>RMDA(A/B/C/D/E/F/G)F7236-( )(1/2/3)</b>	1,121.	1,289.	1,740.
	36"	78"	<b>RMDA(A/B/C/D/E/F/G)F7836-( )(1/2/3)</b>	1,261.	1,449.	1,956.
	36"	84"	<b>RMDA(A/B/C/D/E/F/G)F8436-( )(1/2/3)</b>	1,403.	1,615.	2,180.
	36"	90"	<b>RMDA(A/B/C/D/E/F/G)F9036-( )(1/2/3)</b>	1,478.	1,700.	2,294.
	36"	96"	<b>RMDA(A/B/C/D/E/F/G)F9636-( )(1/2/3)</b>	1,619.	1,859.	2,511.
Wrap-around panel top	21 1/4"	42 1/2"	<b>RMDA(A/B/C/D/E/F/G)F4221-( )(1/2/3)( )</b>	901.	1,036.	1,397.
*No Grommet option	25 1/4"	50 1/2"	<b>RMDA(A/B/C/D/E/F/G)F5025-( )(1/2/3)( )</b>	987.	1,136.	1,533.



Please specify mating end trim profile option.

Order Code	Specification Information	Application Notes
Example: <b>RMDAGF4230F2</b>	<i>To order please specify pattern number including:</i>	<p><b>Knoll assumes no responsibility for special grommet locations which interfere with support or other hardware. All requests for special grommet locations must be approved through custom product development.</b></p> <p>Products on this page are shipped without hardware which must be ordered separately from the support components section.</p> <p>Product on this page will accept woodgrain laminate where laminate is currently an option. List price for woodgrain laminate options will be current published laminate list price plus 10%.</p> <p>Worksurface stiffeners are recommended to provide additional support for open spans greater than 48"w.</p>
<b>R</b> Reff	<ol style="list-style-type: none"> <li>Edge profile</li> <li>Width</li> <li>Depth</li> <li>Grommet option</li> <li>Top finish type</li> <li>Top finish</li> <li>Grommet finish</li> <li>Applicable "wrap around panel tops" only specify mating panel end trim profile</li> </ol>	
<b>MD</b> Peninsula D-shaped top	<ol style="list-style-type: none"> <li>Edge profile options:</li> </ol>	<p>Applicable finishes are listed on page 5 and 6.</p> <p>Products on this page do not accept the following finishes: Y341 Wenge Y342 Medium Teak Y343 Dark Grey Oak</p>
<b>A</b> 1 1/4" thick	<ol style="list-style-type: none"> <li>A = Alpha</li> <li>B = Beta</li> <li>C = Chi</li> <li>D = Delta</li> <li>E = Epsilon</li> <li>F = Phi</li> <li>G = Gamma</li> </ol>	
<b>G</b> Gamma	<ol style="list-style-type: none"> <li>4. Grommet options:</li> </ol>	<p>1 = No grommet C = Centered grommet (applicable RMDA product only) F = Flush front grommet location (for worksurfaces 9 or P tops) R = Recessed front (for worksurfaces 9 or p tops. Not recommended on 20"D and 24"D tops)</p>
<b>F</b> Edge front only	<ol style="list-style-type: none"> <li>5. Finish type:</li> </ol>	
<b>42</b> 42" wide		<ol style="list-style-type: none"> <li>M = Mixed (laminate surface / wood edge)</li> <li>1 = V1</li> <li>2 = V2</li> <li>3 = V3</li> </ol>
<b>30</b> 30" deep		<ol style="list-style-type: none"> <li>8. Additional specification option required for wrap around panel tops only, specify mating trim profile</li> </ol>
<b>C</b> Centered grommet		
<b>2</b> V2 finish		
<b>V319</b> Medium cherry		
<b>111</b> Jet Black (grommet)		

# Optional edge 1 1/4" meeting tops P and 9

description	d	w	pattern no.	V1	V2	V3
Worksurface P-top 	30"	84"	<b>RMPA(A/B/C/D/E/F/G)F8430-( )(1/2/3)</b>	\$1,957.	\$2,254.	\$3,042.
	30"	96"	<b>RMPA(A/B/C/D/E/F/G)F9630-( )(1/2/3)</b>	2,041.	2,347.	3,168.
Worksurface 9-top 	30"	84"	<b>RM9A(A/B/C/D/E/F/G)F8430-( )(1/2/3)</b>	1,957.	2,254.	3,042.
	30"	96"	<b>RM9A(A/B/C/D/E/F/G)F9630-( )(1/2/3)</b>	2,041.	2,347.	3,168.
Meeting P-top (adjoining top must use 12 end panel and modesty panel to support) <b>*No Grommet option</b> 	30"	42"	<b>RM9A(A/B/C/D/E/F/G)F4230-( )(1/2/3)</b>	963.	1,107.	1,492.
	36"	48"	<b>RM9A(A/B/C/D/E/F/G)F4836-( )(1/2/3)</b>	1,070.	1,230.	1,662.
Meeting 9-top (adjoining top must use 12 end panel and modesty panel to support) <b>*No Grommet option</b> 	30"	42"	<b>RMPA(A/B/C/D/E/F/G)F4230-( )(1/2/3)</b>	963.	1,107.	1,492.
	36"	48"	<b>RMPA(A/B/C/D/E/F/G)F4836-( )(1/2/3)</b>	1,070.	1,230.	1,662.

Worksurfaces

Order Code	Specification Information	Application Notes
Example: <b>RMPAGF4230F2</b>	<i>To order please specify pattern number including:</i>	<b>Knoll assumes no responsibility for special grommet locations which interfere with support or other hardware. All requests for special grommet locations must be approved through custom product development.</b>
<b>R</b> Reff	4. Grommet options: N = No grommet C = Centered grommet (applicable RMDA product only) F = Flush front grommet location (for worksurfaces 9 or P tops) R = Recessed front (for worksurfaces 9 or p tops. Not recommended on 20"D and 24"D tops)	
<b>MP</b> Peninsula P-shaped top	1. Edge profile	Products on this page are shipped without hardware which must be ordered separately from the support components section.
<b>A</b> 1 1/4" thick	2. Width	
<b>G</b> Gamma	3. Depth	Product on this page will accept woodgrain laminate where laminate is currently an option. List price for woodgrain laminate options will be current published laminate list price plus 10%.
<b>F</b> Edge front only	4. Grommet option	
<b>42</b> 42" wide	5. Top finish type	Worksurface stiffeners recommended to provide additional support for open spans greater than 48" w.
<b>30</b> 30" deep	6. Top finish	
<b>C</b> Centered grommet	7. Grommet finish	
<b>2</b> V2 finish	8. Applicable "wrap around panel tops" only specify mating panel end trim profile	
<b>V319</b> Medium cherry	<i>1. Edge profile options:</i> A = Alpha B = Beta C = Chi D = Delta E = Epsilon F = Phi G = Gamma	
<b>111</b> Jet Black (grommet)		
	<i>5. Finish type:</i> M = Mixed (laminate surface / wood edge) 1 = V1 2 = V2 3 = V3	
	Applicable finishes are listed on page 5 and 6.	
	Products on this page do not accept the following finishes: Y341 Wenge Y342 Medium Teak Y343 Dark Grey Oak	

# Optional edge 1 1/4"

## Bow front tops

description	w	d	pattern no.	V1	V2	V3
 Profile edge on front and back (30"d)	72"	30"	<b>RMBA(A/B/C/D/E/F/G)A7230-( )(1/2/3)</b>	\$1,168.	\$1,341.	\$1,812.
	84"	30"	<b>RMBA(A/B/C/D/E/F/G)A8430( )(1/2/3)</b>	1,286.	1,480.	1,998.
	96"	30"	<b>RMBA(A/B/C/D/E/F/G)A9630( )(1/2/3)</b>	1,425.	1,637.	2,211.

 Profile edge on front and back (36"d)	72"	36"	<b>RMBA(A/B/C/D/E/F/G)A7236( )(1/2/3)</b>	1,240.	1,424.	1,925.
	84"	36"	<b>RMBA(A/B/C/D/E/F/G)A8436( )(1/2/3)</b>	1,359.	1,564.	2,112.
	96"	36"	<b>RMBA(A/B/C/D/E/F/G)A9636-( )(1/2/3)</b>	1,506.	1,733.	2,338.

 Profile elliptical tops	60"	30"	<b>REBA(A/B/C/D/E/F/G)A6030</b>	1,370.	1,576.	2,127.
	72"	42"	<b>REBA(A/B/C/D/E/F/G)A7242</b>	1,953.	2,243.	3,028.
	78"	48"	<b>REBA(A/B/C/D/E/F/G)A7848</b>	2,140.	2,461.	3,322.

grommet options for elliptical tops, N or R

Order Code	Specification Information	Application Notes
Example: <b>RMBAGA7230F2</b>	<i>To order please specify pattern number including:</i>	<p><b>Knoll assumes no responsibility for special grommet locations which interfere with support or other hardware. All requests for special grommet locations must be approved through custom product development.</b></p> <p>Products on this page are shipped without hardware which must be ordered separately from the support components section.</p> <p>Worksurface stiffeners are recommended to provide additional support for open spans greater than 48" w.</p>
<b>R</b> Reff	1. Edge profile	
<b>MB</b> Bow front top	2. Width	
<b>A</b> 1 1/4" thick	3. Depth	
<b>G</b> Gamma	4. Grommet option	
<b>A</b> Edge front and back	5. Top finish type	
<b>72</b> 72" wide	6. Top finish	
<b>30</b> 30" deep	7. Grommet finish	
<b>F</b> Flush grommet	<i>1. Edge profile options:</i>	
<b>2</b> V2 finish	A = Alpha	
<b>V319</b> Medium cherry	B = Beta	
<b>111</b> Jet Black (grommet)	C = Chi	
	D = Delta	
	E = Epsilon	
	F = Phi	
	G = Gamma	
	4. Grommet options:	
	N = No grommet	
	F = Flush front grommet location	
	R = Recessed front	
	A = Alternate location (only for 36" deep bow front tops)	
	5. Finish type:	
	M = Mixed (laminated surface / wood edge)	
	1 = V1	
	2 = V2	
	3 = V3	
	Applicable finishes are listed on page 5 and 6.	
	Products on this page do not accept the following finishes:	
	Y341 Wenge	
	Y342 Medium Teak	
	Y343 Dark Grey Oak	

# Optional edge 1 1/4" round and racetrack conference tops

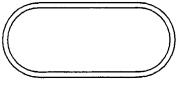
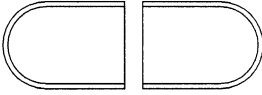
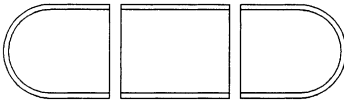
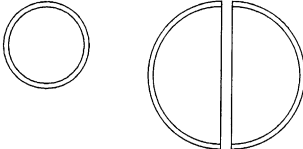
description	w	d	pattern no.	V1	V2	V3
Racetrack top - 1 piece 	72"	30"	<b>RTA(A/B/C/D/E/F/G)7230-(1/2/3)</b>	\$1,370.	\$1,576.	\$2,127.
	72"	36"	<b>RTA(A/B/C/D/E/F/G)7236-(1/2/3)</b>	1,564.	1,795.	2,424.
	84"	30"	<b>RTA(A/B/C/D/E/F/G)8430-(1/2/3)</b>	1,525.	1,757.	2,371.
	84"	36"	<b>RTA(A/B/C/D/E/F/G)8436-(1/2/3)</b>	1,760.	2,018.	2,727.
	84"	42"	<b>RTA(A/B/C/D/E/F/G)8442-(1/2/3)</b>	2,140.	2,461.	3,322.
	96"	30"	<b>RTA(A/B/C/D/E/F/G)9630-(1/2/3)</b>	1,700.	1,955.	2,638.
	96"	36"	<b>RTA(A/B/C/D/E/F/G)9636-(1/2/3)</b>	1,953.	2,243.	3,028.
	96"	42"	<b>RTA(A/B/C/D/E/F/G)9642-(1/2/3)</b>	2,395.	2,754.	3,718.
Racetrack top - 2 piece Profile edge on all sides except on parting lines 	120"	36"	<b>RTA(A/B/C/D/E/F/G)12036-(1/2/3)</b>	2,521.	2,898.	3,912.
	120"	42"	<b>RTA(A/B/C/D/E/F/G)12042-(1/2/3)</b>	2,718.	3,124.	4,218.
	120"	48"	<b>RTA(A/B/C/D/E/F/G)12048-(1/2/3)</b>	2,889.	3,321.	4,483.
	144"	42"	<b>RTA(A/B/C/D/E/F/G)14442-(1/2/3)</b>	2,995.	3,446.	4,650.
	144"	48"	<b>RTA(A/B/C/D/E/F/G)14448-(1/2/3)</b>	3,072.	3,530.	4,767.
Racetrack top - 3 piece Profile edge on all sides except on parting lines 	168"	42"	<b>RTA(A/B/C/D/E/F/G)16842-(1/2/3)</b>	3,756.	4,320.	5,832.
	168"	48"	<b>RTA(A/B/C/D/E/F/G)16848-(1/2/3)</b>	4,017.	4,620.	6,236.
	192"	42"	<b>RTA(A/B/C/D/E/F/G)19242-(1/2/3)</b>	4,038.	4,642.	6,267.
	192"	48"	<b>RTA(A/B/C/D/E/F/G)19248-(1/2/3)</b>	4,201.	4,832.	6,521.
Round tops Profile edge on all sides except on parting lines. 	*	60"	<b>RTA(A/B/C/D/E/F/G)6060-(1/2/3)</b>	2,309.	2,655.	3,583.
	*	72"	<b>RTA(A/B/C/D/E/F/G)7272-(1/2/3)</b>	2,857.	3,286.	4,437.
	-	36"	<b>RTA(A/B/C/D/E/F/G)3636-(1/2/3)</b>	771.	887.	1,197.
	-	42"	<b>RTA(A/B/C/D/E/F/G)4242-(1/2/3)</b>	894.	1,027.	1,388.
	-	48"	<b>RTA(A/B/C/D/E/F/G)4848-(1/2/3)</b>	1,472.	1,692.	2,284.

Worksurfaces

Order Code	Specification Information
Example: <b>RTAG72302</b>	
<b>R</b> Reff	
<b>T</b> Racetrack top	
<b>A</b> 1 1/4" thick	
<b>G</b> Gamma	
<b>72</b> 22" wide	
<b>30</b> 30" deep	
<b>2</b> V2 finish	
<b>V319</b> Medium cherry	

**Specification Information**

To order please specify pattern number including:

- Edge profile
- Width
- Depth
- Finish type
- Finish

1. Edge profile options:  
 A = Alpha  
 B = Beta  
 C = Chi  
 D = Delta  
 E = Epsilon  
 F = Phi  
 G = Gamma

4. Finish type:  
 M = Mixed (laminated surface / wood edge)  
 1 = V1  
 2 = V2  
 3 = V3

\*Round tops in two pieces.

Applicable finishes are listed on page 5 and 6.

Products on this page do not accept the following finishes:  
 Y341 Wenge  
 Y342 Medium Teak  
 Y343 Dark Grey Oak

**Application Notes**

**Knoll assumes no responsibility for special grommet locations which interfere with support or other hardware. All requests for special grommet locations must be approved through custom product development.**

Products on this page are shipped without hardware which must be ordered separately from the support components section.

Worksurface stiffeners are recommended to provide additional support for open spans greater than 48" w.

# Optional edge 1 1/4" square and rectangular conference tops

Reff Profiles

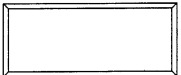
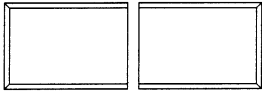
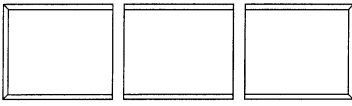
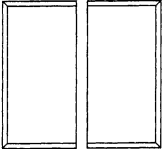
description	w	d	pattern no.	V1	V2	V3
Rectangular top - 1 piece 	72"	30"	<b>RRA(A/B/C/D/E/F/G)7230-(1/2/3)</b>	\$725.	\$833.	\$1,125.
	72"	36"	<b>RRA(A/B/C/D/E/F/G)7236-(1/2/3)</b>	788.	904.	1,221.
	84"	30"	<b>RRA(A/B/C/D/E/F/G)8430-(1/2/3)</b>	801.	924.	1,248.
	84"	36"	<b>RRA(A/B/C/D/E/F/G)8436-(1/2/3)</b>	860.	988.	1,335.
	84"	42"	<b>RRA(A/B/C/D/E/F/G)8442-(1/2/3)</b>	1,273.	1,463.	1,975.
	96"	30"	<b>RRA(A/B/C/D/E/F/G)9630-(1/2/3)</b>	900.	1,034.	1,396.
	96"	36"	<b>RRA(A/B/C/D/E/F/G)9636-(1/2/3)</b>	994.	1,143.	1,545.
	96"	42"	<b>RRA(A/B/C/D/E/F/G)9642-(1/2/3)</b>	1,461.	1,679.	2,266.
Rectangular top - 2 piece Profile edge on all sides except on parting lines 	120"	36"	<b>RRA(A/B/C/D/E/F/G)12036-(1/2/3)</b>	1,594.	1,833.	2,475.
	120"	42"	<b>RRA(A/B/C/D/E/F/G)12042-(1/2/3)</b>	2,199.	2,528.	3,410.
	120"	48"	<b>RRA(A/B/C/D/E/F/G)12048-(1/2/3)</b>	2,389.	2,748.	3,711.
	144"	42"	<b>RRA(A/B/C/D/E/F/G)14442-(1/2/3)</b>	2,468.	2,843.	3,838.
	144"	48"	<b>RRA(A/B/C/D/E/F/G)14448-(1/2/3)</b>	2,648.	3,043.	4,109.
Rectangular top - 3 piece Profile edge on all sides except on parting lines 	168"	42"	<b>RRA(A/B/C/D/E/F/G)16842-(1/2/3)</b>	3,239.	3,725.	5,028.
	168"	48"	<b>RRA(A/B/C/D/E/F/G)16848-(1/2/3)</b>	3,517.	4,048.	5,465.
	192"	42"	<b>RRA(A/B/C/D/E/F/G)19242-(1/2/3)</b>	3,508.	4,037.	5,449.
	192"	48"	<b>RRA(A/B/C/D/E/F/G)19248-(1/2/3)</b>	3,777.	4,344.	5,862.
Square top Profile edge on all sides except on parting lines 	*	60"	<b>RRA(A/B/C/D/E/F/G)6060-(1/2/3)</b>	1,485.	1,708.	2,307.
	*	72"	<b>RRA(A/B/C/D/E/F/G)7272-(1/2/3)</b>	1,751.	2,014.	2,719.
	-	36"	<b>RRA(A/B/C/D/E/F/G)3636-(1/2/3)</b>	560.	643.	868.
	-	42"	<b>RRA(A/B/C/D/E/F/G)4242-(1/2/3)</b>	725.	833.	1,125.
	-	48"	<b>RRA(A/B/C/D/E/F/G)4848-(1/2/3)</b>	953.	1,094.	1,477.

## Order Code

Example: <b>RRAG72302</b>	
<b>R</b>	Reff
<b>R</b>	Conference Room top
<b>A</b>	1 1/4" thick
<b>G</b>	Gamma
<b>72</b>	72" wide
<b>30</b>	30" deep
<b>2</b>	V2 finish
<b>V319</b>	Medium cherry

## Specification Information

To order please specify pattern number including:

1. Edge option
2. Width
3. Depth
4. Finish type
5. Finish

1. Edge profile options:

- A = Alpha
- B = Beta
- C = Chi
- D = Delta
- E = Epsilon
- F = Phi
- G = Gamma

4. Finish type:

- M = Mixed ( laminate surface / wood edge)
- 1 = V1
- 2 = V2
- 3 = V3

\* Square tops in two pieces.

Applicable finishes are listed on page 5 and 6.

Products on this page do not accept the following finishes:  
 Y341 Wenge  
 Y342 Medium Teak  
 Y343 Dark Grey Oak

## Application Notes

**Knoll assumes no responsibility for special grommet locations which interfere with support or other hardware. All requests for special grommet locations must be approved through custom product development.**

Products on this page are shipped without hardware which must be ordered separately from the support components section.

Worksurface stiffeners are recommended to provide additional support for open spans greater than 48"w.



# Waterfall Edge 1 1/4" with 2" Waterfall edge front only 20" and 24" deep

description	d	w	pattern no.	V1	V2	V3	
Straight rectangular work tops Waterfall edge front only 	20"	24"	<b>RSAWF241-( )(1/2/3)</b>	\$736.	\$848.	\$1,144.	
		30"	<b>RSAWF301-( )(1/2/3)</b>	810.	933.	1,261.	
		36"	<b>RSAWF361-( )(1/2/3)</b>	857.	933.	1,326.	
		42"	<b>RSAWF421-( )(1/2/3)</b>	894.	1,025.	1,384.	
		48"	<b>RSAWF481-( )(1/2/3)</b>	929.	1,069.	1,443.	
		54"	<b>RSAWF541-( )(1/2/3)</b>	970.	1,117.	1,508.	
		60"	<b>RSAWF601-( )(1/2/3)</b>	1,045.	1,200.	1,621.	
		66"	<b>RSAWF661-( )(1/2/3)</b>	1,077.	1,240.	1,673.	
		72"	<b>RSAWF721-( )(1/2/3)</b>	1,130.	1,299.	1,757.	
		78"	<b>RSAWF781-( )(1/2/3)</b>	1,149.	1,319.	1,780.	
		84"	<b>RSAWF841-( )(1/2/3)</b>	1,222.	1,405.	1,896.	
		90"	<b>RSAWF901-( )(1/2/3)</b>	1,270.	1,461.	1,973.	
		96"	<b>RSAWF961-( )(1/2/3)</b>	1,319.	1,514.	2,044.	
		24"	24"	<b>RSAWF242-( )(1/2/3)</b>	775.	894.	1,207.
			30"	<b>RSAWF302-( )(1/2/3)</b>	877.	1,010.	1,362.
			36"	<b>RSAWF362-( )(1/2/3)</b>	913.	1,047.	1,415.
42"	<b>RSAWF422-( )(1/2/3)</b>		940.	1,080.	1,458.		
48"	<b>RSAWF482-( )(1/2/3)</b>		1,010.	1,160.	1,566.		
54"	<b>RSAWF542-( )(1/2/3)</b>		1,077.	1,240.	1,673.		
60"	<b>RSAWF602-( )(1/2/3)</b>		1,153.	1,325.	1,788.		
66"	<b>RSAWF662-( )(1/2/3)</b>		1,193.	1,369.	1,850.		
72"	<b>RSAWF722-( )(1/2/3)</b>		1,247.	1,434.	1,934.		
78"	<b>RSAWF782-( )(1/2/3)</b>		1,307.	1,502.	2,028.		
84"	<b>RSAWF842-( )(1/2/3)</b>		1,357.	1,560.	2,106.		
90"	<b>RSAWF902-( )(1/2/3)</b>		1,421.	1,634.	2,207.		
96"	<b>RSAWF962-( )(1/2/3)</b>	1,477.	1,697.	2,293.			

Worksurfaces

Order Code	Specification Information	Application Notes
Example: <b>RSAWF241F2</b>	<i>To order please specify pattern number including:</i>	<b>Knoll assumes no responsibility for special grommet locations which interfere with support or other hardware. All requests for special grommet locations must be approved through custom product development.</b>
<b>R</b> Reff	1. Grommet option	
<b>S</b> Straight top	2. Top finish type	Actual widths of worksurface are 1/16" less than nominal dimension. Actual depth is 1/8" less than nominal dimension.
<b>A</b> 1 1/4" thick	3. Top finish	
<b>WF</b> Waterfall front	4. Grommet finish	Waterfall worksurfaces should be specified in a configuration only with other waterfall worksurfaces.
<b>24</b> 24" wide	<i>1. Grommet options:</i>	
<b>1</b> 20" deep	N = No grommet	Applicable finishes are listed on page 5 and 6.
<b>F</b> Flush grommet	F = Flush front grommet location	
<b>2</b> V2 finish	R = Recessed front	Products on this page do not accept the following finishes: Y341 Wenge Y342 Medium Teak Y343 Dark Grey Oak
<b>V319</b> Medium cherry	(not recommended on 20"D and 24"D tops)	
<b>111</b> Jet Black (grommet)	<i>2. Finish type:</i>	Products on this page are shipped without hardware which must be ordered separately from the support components section.
	1 = V1	
	2 = V2	
	3 = V3	Worksurface stiffeners are recommended to provide additional support for open spans greater than 48"w.

Waterfall Edge 1 1/4"  
with 2" Waterfall edge front only  
30" and 36" deep

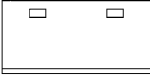
description	d	w	pattern no.	V1	V2	V3	
Straight rectangular work tops Waterfall edge front only 	30"	24"	<b>RSAWF243-</b> ( )(1/2/3)	\$844.	\$973.	\$1,314.	
		30"	<b>RSAWF303-</b> ( )(1/2/3)	948.	1,092.	1,474.	
		36"	<b>RSAWF363-</b> ( )(1/2/3)	1,023.	1,175.	1,587.	
		42"	<b>RSAWF423-</b> ( )(1/2/3)	1,066.	1,224.	1,653.	
		48"	<b>RSAWF483-</b> ( )(1/2/3)	1,137.	1,310.	1,768.	
		54"	<b>RSAWF543-</b> ( )(1/2/3)	1,229.	1,416.	1,911.	
		60"	<b>RSAWF603-</b> ( )(1/2/3)	1,276.	1,466.	1,980.	
		66"	<b>RSAWF663-</b> ( )(1/2/3)	1,304.	1,498.	2,025.	
		72"	<b>RSAWF723-</b> ( )(1/2/3)	1,336.	1,535.	2,071.	
		78"	<b>RSAWF783-</b> ( )(1/2/3)	1,398.	1,607.	2,168.	
		84"	<b>RSAWF843-</b> ( )(1/2/3)	1,453.	1,673.	2,258.	
		90"	<b>RSAWF903-</b> ( )(1/2/3)	1,522.	1,746.	2,357.	
		96"	<b>RSAWF963-</b> ( )(1/2/3)	1,577.	1,813.	2,447.	
		36"	60"	<b>RSAWF604-</b> ( )(1/2/3)	1,473.	1,690.	2,281.
			66"	<b>RSAWF664-</b> ( )(1/2/3)	1,524.	1,751.	2,365.
			72"	<b>RSAWF724-</b> ( )(1/2/3)	1,574.	1,809.	2,441.

Order Code	Specification Information	Application Notes
Example: <b>RSAWF243F2</b>	<i>To order please specify pattern number including:</i>	<b>Knoll assumes no responsibility for special grommet locations which interfere with support or other hardware. All requests for special grommet locations must be approved through custom product development.</b>
<b>R</b> Reff	1. Grommet option	
<b>S</b> Straight top	2. Top finish type	Actual widths of worksurface are 1/16" less than nominal dimension. Actual depth is 1/8" less than nominal dimension.
<b>A</b> 1 1/4" thick	3. Top finish	
<b>WF</b> Waterfall front	4. Grommet finish	Waterfall worksurfaces should be specified in a configuration only with other waterfall worksurfaces.
<b>24</b> 24" wide	<i>1. Grommet options:</i>	Applicable finishes are listed on page 5 and 6.
<b>3</b> 30" deep	N = No grommet	
<b>F</b> Flush grommet	F = Flush front grommet location	Products on this page do not accept the following finishes: Y341 Wenge Y342 Medium Teak Y343 Dark Grey Oak
<b>2</b> V2 finish	R = Recessed front (not recommended on 20"D and 24"D tops)	
<b>V319</b> Medium cherry	2. <i>Finish type:</i>	Products on this page are shipped without hardware which must be ordered separately from the support components section.
<b>111</b> Jet black (grommet)	1 = V1	
	2 = V2	
	3 = V3	Worksurface stiffeners are recommended to provide additional support for open spans greater than 48"w.

# Waterfall Edge 1 1/4" with 2" Waterfall edge front and back 20" and 24" deep

Reff Profiles

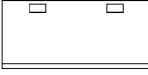
description	d	w	pattern no.	V1	V2	V3	
Straight rectangular work tops Waterfall edge front and back only 	20"	24"	<b>RSAWA241-</b> ( )(1/2/3)	\$920.	\$1,062.	\$1,434.	
		30"	<b>RSAWA301-</b> ( )(1/2/3)	1,015.	1,166.	1,572.	
		36"	<b>RSAWA361-</b> ( )(1/2/3)	1,070.	1,227.	1,659.	
		42"	<b>RSAWA421-</b> ( )(1/2/3)	1,118.	1,284.	1,734.	
		48"	<b>RSAWA481-</b> ( )(1/2/3)	1,160.	1,336.	1,803.	
		54"	<b>RSAWA541-</b> ( )(1/2/3)	1,212.	1,395.	1,884.	
		60"	<b>RSAWA601-</b> ( )(1/2/3)	1,308.	1,500.	2,026.	
		66"	<b>RSAWA661-</b> ( )(1/2/3)	1,347.	1,549.	2,092.	
		72"	<b>RSAWA721-</b> ( )(1/2/3)	1,416.	1,629.	2,199.	
		78"	<b>RSAWA781-</b> ( )(1/2/3)	1,437.	1,647.	2,225.	
		84"	<b>RSAWA841-</b> ( )(1/2/3)	1,527.	1,756.	2,370.	
		90"	<b>RSAWA901-</b> ( )(1/2/3)	1,590.	1,828.	2,466.	
		96"	<b>RSAWA961-</b> ( )(1/2/3)	1,647.	1,896.	2,559.	
		24"	24"	<b>RSAWA242-</b> ( )(1/2/3)	970.	1,118.	1,509.
			30"	<b>RSAWA302-</b> ( )(1/2/3)	1,096.	1,262.	1,704.
			36"	<b>RSAWA362-</b> ( )(1/2/3)	1,141.	1,313.	1,772.
			42"	<b>RSAWA422-</b> ( )(1/2/3)	1,175.	1,350.	1,825.
48"	<b>RSAWA482-</b> ( )(1/2/3)		1,262.	1,452.	1,959.		
54"	<b>RSAWA542-</b> ( )(1/2/3)		1,347.	1,549.	2,092.		
60"	<b>RSAWA602-</b> ( )(1/2/3)		1,443.	1,660.	2,240.		
66"	<b>RSAWA662-</b> ( )(1/2/3)		1,492.	1,713.	2,312.		
72"	<b>RSAWA722-</b> ( )(1/2/3)		1,557.	1,791.	2,420.		
78"	<b>RSAWA782-</b> ( )(1/2/3)		1,634.	1,881.	2,537.		
84"	<b>RSAWA842-</b> ( )(1/2/3)		1,697.	1,954.	2,636.		
90"	<b>RSAWA902-</b> ( )(1/2/3)	1,778.	2,043.	2,758.			
96"	<b>RSAWA962-</b> ( )(1/2/3)	1,845.	2,120.	2,862.			

Worksurfaces

Order Code	Specification Information	Application Notes
Example: <b>RSAWA241F2</b>	<i>To order please specify pattern number including:</i>	<b>Knoll assumes no responsibility for special grommet locations which interfere with support or other hardware. All requests for special grommet locations must be approved through custom product development.</b>
<b>R</b> Reff	1. Grommet option	
<b>S</b> Straight top	2. Top finish type	Waterfall worksurfaces should be specified in a configuration only with other waterfall worksurfaces.
<b>A</b> 1 1/4" thick	3. Top finish	
<b>WA</b> Waterfall front/back	4. Grommet finish	Actual widths of worksurface are 1/16" less than nominal dimension. Actual depth is 1/8" less than nominal dimension.
<b>24</b> 24" wide	<i>1. Grommet options:</i>	Applicable finishes are listed on page 5 and 6.
<b>1</b> 20" deep	N = No grommet	
<b>F</b> Flush grommet	F = Flush front grommet location	Products on this page do not accept the following finishes: Y341 Wenge Y342 Medium Teak Y343 Dark Grey Oak
<b>2</b> V2 finish	R = Recessed front (not recommended on 20"D and 24"D tops)	
<b>V319</b> Medium cherry	2. <i>Finish type:</i>	Products on this page are shipped without hardware which must be ordered separately from the support components section.
<b>111</b> Jet Black (grommet)	1 = V1	
	2 = V2	
	3 = V3	Worksurface stiffeners are recommended to provide additional support for open spans greater than 48"w.

Waterfall Edge 1 1/4"  
with 2" Waterfall edge front and back  
30" and 36" deep

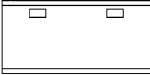
description	d	w	pattern no.	V1	V2	V3	
Straight rectangular work tops Waterfall edge front and back only 	30"	24"	<b>RSAWA243-( ) (1/2/3)</b>	\$1,058.	\$1,216.	\$1,641.	
		30"	<b>RSAWA303-( ) (1/2/3)</b>	1,187.	1,367.	1,846.	
		36"	<b>RSAWA363-( ) (1/2/3)</b>	1,280.	1,472.	1,987.	
		42"	<b>RSAWA423-( ) (1/2/3)</b>	1,334.	1,532.	2,067.	
		48"	<b>RSAWA483-( ) (1/2/3)</b>	1,422.	1,636.	2,209.	
		54"	<b>RSAWA543-( ) (1/2/3)</b>	1,538.	1,769.	2,388.	
		60"	<b>RSAWA603-( ) (1/2/3)</b>	1,594.	1,834.	2,477.	
		66"	<b>RSAWA663-( ) (1/2/3)</b>	1,631.	1,876.	2,532.	
		72"	<b>RSAWA723-( ) (1/2/3)</b>	1,670.	1,919.	2,591.	
		78"	<b>RSAWA783-( ) (1/2/3)</b>	1,746.	2,011.	2,713.	
		84"	<b>RSAWA843-( ) (1/2/3)</b>	1,817.	2,092.	2,824.	
		90"	<b>RSAWA903-( ) (1/2/3)</b>	1,900.	2,185.	2,951.	
		96"	<b>RSAWA963-( ) (1/2/3)</b>	1,969.	2,265.	3,058.	
		36"	60"	<b>RSAWA604-( ) (1/2/3)</b>	1,841.	2,113.	2,853.
			66"	<b>RSAWA664-( ) (1/2/3)</b>	1,904.	2,191.	2,957.
			72"	<b>RSAWA724-( ) (1/2/3)</b>	1,966.	2,261.	3,052.

Order Code	Specification Information	Application Notes
Example: <b>RSAWA243F2</b>	<i>To order please specify pattern number including:</i>	<b>Knoll assumes no responsibility for special grommet locations which interfere with support or other hardware. All requests for special grommet locations must be approved through custom product development.</b>
<b>R</b> Reff	1. Grommet option	
<b>S</b> Straight top	2. Top finish type	Waterfall worksurfaces should be specified in a configuration only with other waterfall worksurfaces.
<b>A</b> 1 1/4" thick	3. Top finish	
<b>WA</b> Waterfall front/back	4. Grommet finish	Actual widths of worksurface are 1/16" less than nominal dimension. Actual depth is 1/8" less than nominal dimension.
<b>24</b> 24" wide	<i>1. Grommet options:</i>	Applicable finishes are listed on page 5 and 6.
<b>3</b> 30" deep	N = No grommet	
<b>F</b> Flush grommet	F = Flush front grommet location	Products on this page do not accept the following finishes: Y341 Wenge Y342 Medium Teak Y343 Dark Grey Oak
<b>2</b> V2 finish	R = Recessed front (not recommended on 20"D and 24"D tops)	
<b>V319</b> Medium cherry	<i>2. Finish type:</i>	Products on this page are shipped without hardware which must be ordered separately from the support components section.
<b>111</b> Jet Black (grommet)	1 = V1	
	2 = V2	
	3 = V3	Worksurface stiffeners are recommended to provide additional support for open spans greater than 48"w.

# Waterfall Edge 1 1/4" with 2" Waterfall edge front and two sides 20" and 24" deep

Reff Profiles

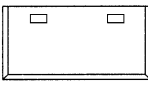
description	d	w	pattern no.	V1	V2	V3	
Straight rectangular work tops Waterfall edge front and two sides 	20"	24"	RSAWB241-( )(1/2/3)	\$1,109.	\$1,272.	\$1,717.	
		30"	RSAWB301-( )(1/2/3)	1,216.	1,396.	1,885.	
		36"	RSAWB361-( )(1/2/3)	1,282.	1,474.	1,990.	
		42"	RSAWB421-( )(1/2/3)	1,340.	1,539.	2,078.	
		48"	RSAWB481-( )(1/2/3)	1,392.	1,603.	2,163.	
		54"	RSAWB541-( )(1/2/3)	1,454.	1,674.	2,261.	
		60"	RSAWB601-( )(1/2/3)	1,571.	1,804.	2,435.	
		66"	RSAWB661-( )(1/2/3)	1,617.	1,858.	2,510.	
		72"	RSAWB721-( )(1/2/3)	1,697.	1,953.	2,635.	
		78"	RSAWB781-( )(1/2/3)	1,718.	1,977.	2,669.	
		84"	RSAWB841-( )(1/2/3)	1,831.	2,108.	2,845.	
		90"	RSAWB901-( )(1/2/3)	1,908.	2,193.	2,960.	
		96"	RSAWB961-( )(1/2/3)	1,977.	2,275.	3,071.	
		24"	24"	RSAWB242-( )(1/2/3)	1,165.	1,340.	1,809.
			30"	RSAWB302-( )(1/2/3)	1,317.	1,510.	2,040.
			36"	RSAWB362-( )(1/2/3)	1,368.	1,574.	2,126.
			42"	RSAWB422-( )(1/2/3)	1,411.	1,623.	2,193.
			48"	RSAWB482-( )(1/2/3)	1,510.	1,741.	2,351.
			54"	RSAWB542-( )(1/2/3)	1,617.	1,858.	2,510.
			60"	RSAWB602-( )(1/2/3)	1,733.	1,989.	2,686.
66"	RSAWB662-( )(1/2/3)		1,788.	2,056.	2,775.		
72"	RSAWB722-( )(1/2/3)		1,869.	2,152.	2,903.		
78"	RSAWB782-( )(1/2/3)		1,959.	2,256.	3,045.		
84"	RSAWB842-( )(1/2/3)		2,037.	2,340.	3,161.		
90"	RSAWB902-( )(1/2/3)		2,131.	2,451.	3,308.		
96"	RSAWB962-( )(1/2/3)	2,211.	2,547.	3,439.			

Worksurfaces

Order Code	Specification Information	Application Notes
Example: <b>RSAWB241F2</b>	<i>To order please specify pattern number including:</i>	<p><b>Knoll assumes no responsibility for special grommet locations which interfere with support or other hardware. All requests for special grommet locations must be approved through custom product development.</b></p> <p><b>Waterfall tops cannot be specified with semi-open pore finish.</b></p> <p>Products on this page are shipped without hardware which must be ordered separately from the support components section.</p> <p>Worksurface stiffeners are recommended to provide additional support for open spans greater than 48" w.</p>
<b>R</b> Reff	1. Grommet option	
<b>S</b> Straight top	2. Top finish type	<p>Waterfall worksurfaces should be specified in a configuration only with other waterfall worksurfaces.</p> <p>Actual widths of worksurface are 1/16" less than nominal dimension. Actual depth is 1/8" less than nominal dimension.</p> <p>Applicable finishes are listed on page 5 and 6.</p> <p>Products on this page do not accept the following finishes: Y341 Wenge Y342 Medium Teak Y343 Dark Grey Oak</p>
<b>A</b> 1 1/4" thick	3. Top finish	
<b>WB</b> Waterfall front and 2 sides	4. Grommet finish	
<b>24</b> 24" wide	<i>1. Grommet options:</i>	
<b>1</b> 20" deep	N = No grommet	
<b>F</b> Flush grommet	F = Flush front grommet location	
<b>2</b> V2 finish	R = Recessed front (not recommended on 20"D and 24"D tops)	
<b>V319</b> Medium cherry	<i>2. Finish type:</i>	
<b>111</b> Jet Black (grommet)	1 = V1	
	2 = V2	
	3 = V3	

Waterfall Edge 1 1/4"  
with 2" Waterfall edge front and two sides  
30" and 36" deep

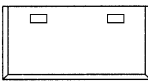
description	d	w	pattern no.	V1	V2	V3	
Straight rectangular work tops Waterfall edge front and two sides 	30"	24"	RSAWB243-( )(1/2/3)	\$1,268.	\$1,459.	\$1,969.	
		30"	RSAWB303-( )(1/2/3)	1,425.	1,640.	2,213.	
		36"	RSAWB363-( )(1/2/3)	1,535.	1,765.	2,383.	
		42"	RSAWB423-( )(1/2/3)	1,599.	1,836.	2,479.	
		48"	RSAWB483-( )(1/2/3)	1,708.	1,962.	2,650.	
		54"	RSAWB543-( )(1/2/3)	1,846.	2,120.	2,862.	
		60"	RSAWB603-( )(1/2/3)	1,912.	2,199.	2,969.	
		66"	RSAWB663-( )(1/2/3)	1,956.	2,250.	3,036.	
		72"	RSAWB723-( )(1/2/3)	2,002.	2,303.	3,108.	
		78"	RSAWB783-( )(1/2/3)	2,099.	2,415.	3,259.	
		84"	RSAWB843-( )(1/2/3)	2,178.	2,507.	3,384.	
		90"	RSAWB903-( )(1/2/3)	2,279.	2,623.	3,542.	
		96"	RSAWB963-( )(1/2/3)	2,366.	2,718.	3,669.	
		36"	60"	RSAWB604-( )(1/2/3)	2,207.	2,537.	3,426.
			66"	RSAWB664-( )(1/2/3)	2,282.	2,627.	3,546.
			72"	RSAWB724-( )(1/2/3)	2,363.	2,713.	3,664.

Order Code	Specification Information	Application Notes
Example: <b>RSAWB243F2</b>	<i>To order please specify pattern number including:</i>	<b>Knoll assumes no responsibility for special grommet locations which interfere with support or other hardware. All requests for special grommet locations must be approved through custom product development.</b>
<b>R</b> Reff	1. Grommet option	Waterfall worksurfaces should be specified in a configuration only with other waterfall worksurfaces.
<b>S</b> Straight top	2. Top finish type	Actual widths of worksurface are 1/16" less than nominal dimension. Actual depth is 1/8" less than nominal dimension.
<b>A</b> 1 1/4" thick	3. Top finish	Applicable finishes are listed on page 5 and 6.
<b>WB</b> Waterfall front and 2 sides	4. Grommet finish	Products on this page do not accept the following finishes: Y341 Wenge Y342 Medium Teak Y343 Dark Grey Oak
<b>24</b> 24" wide	<i>1. Grommet options:</i>	
<b>3</b> 30" deep	N = No grommet	
<b>F</b> Flush grommet	F = Flush front grommet location	
<b>2</b> V2 finish	R = Recessed front (not recommended on 20"D and 24"D tops)	Products on this page are shipped without hardware which must be ordered separately from the support components section.
<b>V319</b> Medium cherry	<i>2. Finish type:</i>	Worksurface stiffeners are recommended to provide additional support for open spans greater than 48"w.
<b>111</b> Jet Black (grommet)	1 = V1	
	2 = V2	
	3 = V3	

Waterfall Edge 1 1/4"  
with 2" Waterfall edge front and left side  
20" and 24" deep

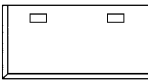
description	d	w	pattern no.	V1	V2	V3
Straight rectangular work tops Waterfall edge front and left side 	20"	24"	RSAWL241-( )(1/2/3)	\$1,015.	\$1,167.	\$1,573.
		30"	RSAWL301-( )(1/2/3)	1,116.	1,281.	1,730.
		36"	RSAWL361-( )(1/2/3)	1,175.	1,350.	1,825.
		42"	RSAWL421-( )(1/2/3)	1,227.	1,411.	1,905.
		48"	RSAWL481-( )(1/2/3)	1,277.	1,468.	1,983.
		54"	RSAWL541-( )(1/2/3)	1,335.	1,534.	2,070.
		60"	RSAWL601-( )(1/2/3)	1,439.	1,653.	2,232.
		66"	RSAWL661-( )(1/2/3)	1,481.	1,706.	2,304.
		72"	RSAWL721-( )(1/2/3)	1,555.	1,788.	2,415.
		78"	RSAWL781-( )(1/2/3)	1,579.	1,814.	2,448.
		84"	RSAWL841-( )(1/2/3)	1,680.	1,931.	2,607.
		90"	RSAWL901-( )(1/2/3)	1,746.	2,011.	2,713.
		96"	RSAWL961-( )(1/2/3)	1,814.	2,086.	2,815.
	24"	24"	RSAWL242-( )(1/2/3)	1,067.	1,227.	1,659.
		30"	RSAWL302-( )(1/2/3)	1,207.	1,388.	1,872.
		36"	RSAWL362-( )(1/2/3)	1,255.	1,443.	1,947.
		42"	RSAWL422-( )(1/2/3)	1,293.	1,487.	2,006.
		48"	RSAWL482-( )(1/2/3)	1,388.	1,595.	2,154.
		54"	RSAWL542-( )(1/2/3)	1,481.	1,706.	2,304.
		60"	RSAWL602-( )(1/2/3)	1,587.	1,821.	2,460.
		66"	RSAWL662-( )(1/2/3)	1,638.	1,885.	2,545.
		72"	RSAWL722-( )(1/2/3)	1,713.	1,969.	2,658.
		78"	RSAWL782-( )(1/2/3)	1,793.	2,066.	2,790.
		84"	RSAWL842-( )(1/2/3)	1,863.	2,148.	2,899.
		90"	RSAWL902-( )(1/2/3)	1,955.	2,248.	3,032.
		96"	RSAWL962-( )(1/2/3)	2,028.	2,334.	3,151.

Worksurfaces

Order Code	Specification Information	Application Notes
Example: <b>RSAWL241F2</b>	<i>To order please specify pattern number including:</i>	<b>Knoll assumes no responsibility for special grommet locations which interfere with support or other hardware. All requests for special grommet locations must be approved through custom product development.</b>
<b>R</b> Reff	1. Grommet option	
<b>S</b> Straight top	2. Top finish type	Waterfall worksurfaces should be specified in a configuration only with other waterfall worksurfaces.
<b>A</b> 1 1/4" thick	3. Top finish	
<b>WL</b> Waterfall front and left	4. Grommet finish	Actual widths of worksurface are 1/16" less than nominal dimension. Actual depth is 1/8" less than nominal dimension.
<b>24</b> 24" wide	<i>1. Grommet options:</i>	Applicable finishes are listed on page 5 and 6.
<b>1</b> 20" deep	N = No grommet	
<b>F</b> Flush grommet	F = Flush front grommet location	Products on this page do not accept the following finishes: Y341 Wenge Y342 Medium Teak Y343 Dark Grey Oak
<b>2</b> V2 finish	R = Recessed front (not recommended on 20"D and 24"D tops)	
<b>V319</b> Medium cherry	<i>2. Finish type:</i>	Products on this page are shipped without hardware which must be ordered separately from the support components section.
<b>111</b> Jet Black (grommet)	1 = V1	
	2 = V2	
	3 = V3	Worksurface stiffeners are recommended to provide additional support for open spans greater than 48"w.

Waterfall Edge 1 1/4"  
with 2" Waterfall edge front and left side  
30" and 36" deep

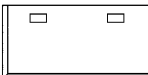
description	d	w	pattern no.	V1	V2	V3	
Straight rectangular work tops Waterfall edge front and left side 	30"	24"	RSAWL243-( )(1/2/3)	\$1,165.	\$1,338.	\$1,806.	
		30"	RSAWL303-( )(1/2/3)	1,307.	1,502.	2,028.	
		36"	RSAWL363-( )(1/2/3)	1,407.	1,618.	2,185.	
		42"	RSAWL423-( )(1/2/3)	1,464.	1,684.	2,272.	
		48"	RSAWL483-( )(1/2/3)	1,565.	1,803.	2,434.	
		54"	RSAWL543-( )(1/2/3)	1,690.	1,947.	2,629.	
		60"	RSAWL603-( )(1/2/3)	1,754.	2,015.	2,721.	
		66"	RSAWL663-( )(1/2/3)	1,790.	2,063.	2,786.	
		72"	RSAWL723-( )(1/2/3)	1,836.	2,110.	2,848.	
		78"	RSAWL783-( )(1/2/3)	1,922.	2,211.	2,985.	
		84"	RSAWL843-( )(1/2/3)	1,998.	2,300.	3,105.	
		90"	RSAWL903-( )(1/2/3)	2,092.	2,406.	3,248.	
		96"	RSAWL963-( )(1/2/3)	2,167.	2,490.	3,363.	
		36"	60"	RSAWL604-( )(1/2/3)	2,024.	2,326.	3,141.
			66"	RSAWL664-( )(1/2/3)	2,095.	2,408.	3,250.
			72"	RSAWL724-( )(1/2/3)	2,164.	2,487.	3,358.

Order Code	Specification Information	Application Notes
Example: <b>RSAWL243F2</b>	<i>To order please specify pattern number including:</i>	<b>Knoll assumes no responsibility for special grommet locations which interfere with support or other hardware. All requests for special grommet locations must be approved through custom product development.</b>
<b>R</b> Reff	1. Grommet option	
<b>S</b> Straight top	2. Top finish type	Waterfall worksurfaces should be specified in a configuration only with other waterfall worksurfaces.
<b>A</b> 1 1/4" thick	3. Top finish	
<b>WL</b> Waterfall front and left	4. Grommet finish	Actual widths of worksurface are 1/16" less than nominal dimension. Actual depth is 1/8" less than nominal dimension.
<b>24</b> 24" wide	<i>1. Grommet options:</i>	Applicable finishes are listed on page 5 and 6.
<b>3</b> 30" deep	N = No grommet	
<b>F</b> Flush grommet	F = Flush front grommet location	Products on this page do not accept the following finishes: Y341 Wenge Y342 Medium Teak Y343 Dark Grey Oak
<b>2</b> V2 finish	R = Recessed front (not recommended on 20"D and 24"D tops)	
<b>V319</b> Medium cherry	<i>2. Finish type:</i>	Products on this page are shipped without hardware which must be ordered separately from the support components section.
<b>111</b> Jet Black (grommet)	1 = V1	
	2 = V2	
	3 = V3	Worksurface stiffeners are recommended to provide additional support for open spans greater than 48"w.



# Waterfall Edge 1 1/4" with 2" Waterfall edge front and right side 20" and 24" deep

Reff Profiles

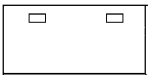
description	d	w	pattern no.	V1	V2	V3
Straight rectangular work tops Waterfall edge front and right side 	20"	24"	RSAWR241-( )(1/2/3)	\$1,015.	\$1,167.	\$1,573.
		30"	RSAWR301-( )(1/2/3)	1,116.	1,281.	1,730.
		36"	RSAWR361-( )(1/2/3)	1,175.	1,350.	1,825.
		42"	RSAWR421-( )(1/2/3)	1,227.	1,411.	1,905.
		48"	RSAWR481-( )(1/2/3)	1,277.	1,468.	1,983.
		54"	RSAWR541-( )(1/2/3)	1,335.	1,534.	2,070.
		60"	RSAWR601-( )(1/2/3)	1,439.	1,653.	2,232.
		66"	RSAWR661-( )(1/2/3)	1,481.	1,706.	2,304.
		72"	RSAWR721-( )(1/2/3)	1,555.	1,788.	2,415.
		78"	RSAWR781-( )(1/2/3)	1,579.	1,814.	2,448.
		84"	RSAWR841-( )(1/2/3)	1,680.	1,931.	2,607.
		90"	RSAWR901-( )(1/2/3)	1,746.	2,011.	2,713.
		96"	RSAWR961-( )(1/2/3)	1,814.	2,086.	2,815.
	24"	24"	RSAWR242-( )(1/2/3)	1,067.	1,227.	1,659.
		30"	RSAWR302-( )(1/2/3)	1,207.	1,388.	1,872.
		36"	RSAWR362-( )(1/2/3)	1,255.	1,443.	1,947.
		42"	RSAWR422-( )(1/2/3)	1,293.	1,487.	2,006.
		48"	RSAWR482-( )(1/2/3)	1,388.	1,595.	2,154.
		54"	RSAWR542-( )(1/2/3)	1,481.	1,706.	2,304.
		60"	RSAWR602-( )(1/2/3)	1,587.	1,821.	2,460.
		66"	RSAWR662-( )(1/2/3)	1,638.	1,885.	2,545.
		72"	RSAWR722-( )(1/2/3)	1,713.	1,969.	2,658.
		78"	RSAWR782-( )(1/2/3)	1,793.	2,066.	2,790.
		84"	RSAWR842-( )(1/2/3)	1,863.	2,148.	2,899.
		90"	RSAWR902-( )(1/2/3)	1,955.	2,248.	3,032.
		96"	RSAWR962-( )(1/2/3)	2,028.	2,334.	3,151.

Worksurfaces

Order Code	Specification Information	Application Notes
Example: <b>RSAWR241F2</b>	<i>To order please specify pattern number including:</i>	<b>Knoll assumes no responsibility for special grommet locations which interfere with support or other hardware. All requests for special grommet locations must be approved through custom product development.</b>
<b>R</b> Reff	1. Grommet option	
<b>S</b> Straight top	2. Top finish type	Waterfall worksurfaces should be specified in a configuration only with other waterfall worksurfaces.
<b>A</b> 1 1/4" thick	3. Top finish	
<b>WR</b> Waterfall front and right	4. Grommet finish	Actual widths of worksurface are 1/16" less than nominal dimension. Actual depth is 1/8" less than nominal dimension.
<b>24</b> 24" wide	<i>1. Grommet options:</i>	Applicable finishes are listed on page 5 and 6.
<b>1</b> 20" deep	N = No grommet	
<b>F</b> Flush grommet	F = Flush front grommet location	Products on this page do not accept the following finishes: Y341 Wenge Y342 Medium Teak Y343 Dark Grey Oak
<b>2</b> V2 finish	R = Recessed front (not recommended on 20"D and 24"D tops)	
<b>V319</b> Medium cherry	<i>2. Finish type:</i>	
<b>111</b> Jet Black (grommet)	1 = V1	
	2 = V2	
	3 = V3	
		Products on this page are shipped without hardware which must be ordered separately from the support components section.
		Worksurface stiffeners are recommended to provide additional support for open spans greater than 48" w.

Waterfall Edge 1 1/4"  
with 2" Waterfall edge front and right side  
30" and 36" deep

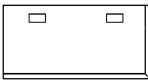
description	d	w	pattern no.	V1	V2	V3	
Straight rectangular work tops Waterfall edge front and right side 	30"	24"	RSAWR243-( )(1/2/3)	\$1,165.	\$1,338.	\$1,806.	
		30"	RSAWR303-( )(1/2/3)	1,307.	1,502.	2,028.	
		36"	RSAWR363-( )(1/2/3)	1,407.	1,618.	2,185.	
		42"	RSAWR423-( )(1/2/3)	1,464.	1,684.	2,272.	
		48"	RSAWR483-( )(1/2/3)	1,565.	1,803.	2,434.	
		54"	RSAWR543-( )(1/2/3)	1,690.	1,947.	2,629.	
		60"	RSAWR603-( )(1/2/3)	1,754.	2,015.	2,721.	
		66"	RSAWR663-( )(1/2/3)	1,790.	2,063.	2,786.	
		72"	RSAWR723-( )(1/2/3)	1,836.	2,110.	2,848.	
		78"	RSAWR783-( )(1/2/3)	1,922.	2,211.	2,985.	
		84"	RSAWR843-( )(1/2/3)	1,998.	2,300.	3,105.	
		90"	RSAWR903-( )(1/2/3)	2,092.	2,406.	3,248.	
		96"	RSAWR963-( )(1/2/3)	2,167.	2,490.	3,363.	
		36"	60"	RSAWR604-( )(1/2/3)	2,024.	2,326.	3,141.
			66"	RSAWR664-( )(1/2/3)	2,095.	2,408.	3,250.
	72"	RSAWR724-( )(1/2/3)	2,164.	2,487.	3,358.		

Order Code	Specification Information	Application Notes
Example: <b>RSAWR243F2</b>	<i>To order please specify pattern number including:</i>	<b>Knoll assumes no responsibility for special grommet locations which interfere with support or other hardware. All requests for special grommet locations must be approved through custom product development.</b>
<b>R</b> Reff	1. Grommet option	
<b>S</b> Straight top	2. Top finish type	Waterfall worksurfaces should be specified in a configuration only with other waterfall worksurfaces.
<b>A</b> 1 1/4" thick	3. Top finish	
<b>WR</b> Waterfall front and right	4. Grommet finish	Actual widths of worksurface are 1/16" less than nominal dimension. Actual depth is 1/8" less than nominal dimension.
<b>24</b> 24" wide	<i>1. Grommet options:</i>	Applicable finishes are listed on page 5 and 6.
<b>3</b> 30" deep	N = No grommet	
<b>F</b> Flush grommet	F = Flush front grommet location	Products on this page do not accept the following finishes: Y341 Wenge Y342 Medium Teak Y343 Dark Grey Oak
<b>2</b> V2 finish	R = Recessed front (not recommended on 20"D and 24"D tops)	
<b>V319</b> Medium cherry	2. <i>Finish type:</i>	Products on this page are shipped without hardware which must be ordered separately from the support components section.
<b>111</b> Jet Black (grommet)	1 = V1	
	2 = V2	
	3 = V3	Worksurface stiffeners are recommended to provide additional support for open spans greater than 48"w.

# Waterfall Edge 1 1/4"

Reff Profiles

## 2" Waterfall edge front only curvilinear transition and end tops

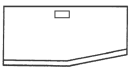
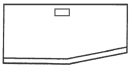
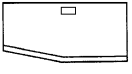
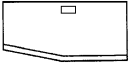
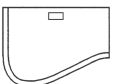
description	d left	w	d right	pattern no.	V1	V2	V3
Wave transition top with waterfall edge front only (left 24", right 30") 	24"	42"	30"	<b>RWAWF4223-</b> ( )(1/2/3)	\$1,069.	\$1,227.	\$1,659.
	24"	48"	30"	<b>RWAWF4823-</b> ( )(1/2/3)	1,113.	1,279.	1,726.
	24"	54"	30"	<b>RWAWF5423-</b> ( )(1/2/3)	1,198.	1,382.	1,864.
	24"	60"	30"	<b>RWAWF6023-</b> ( )(1/2/3)	1,282.	1,478.	1,995.
	24"	66"	30"	<b>RWAWF6623-</b> ( )(1/2/3)	1,330.	1,529.	2,063.
	24"	72"	30"	<b>RWAWF7223-</b> ( )(1/2/3)	1,395.	1,606.	2,167.
Wave transition top with waterfall edge front only (left 30", right 24") 	30"	42"	24"	<b>RWAWF4232-</b> ( )(1/2/3)	1,069.	1,227.	1,659.
	30"	48"	24"	<b>RWAWF4832-</b> ( )(1/2/3)	1,113.	1,279.	1,726.
	30"	54"	24"	<b>RWAWF5432-</b> ( )(1/2/3)	1,198.	1,382.	1,864.
	30"	60"	24"	<b>RWAWF6032-</b> ( )(1/2/3)	1,282.	1,478.	1,995.
	30"	66"	24"	<b>RWAWF6632-</b> ( )(1/2/3)	1,330.	1,529.	2,063.
	30"	72"	24"	<b>RWAWF7232-</b> ( )(1/2/3)	1,395.	1,606.	2,167.
Wave transition top with waterfall edge front only (left 20", right 24") 	20"	42"	24"	<b>RWAWF4212-</b> ( )(1/2/3)	990.	1,141.	1,541.
	20"	48"	24"	<b>RWAWF4812-</b> ( )(1/2/3)	1,042.	1,198.	1,618.
	20"	54"	24"	<b>RWAWF5412-</b> ( )(1/2/3)	1,116.	1,282.	1,731.
	20"	60"	24"	<b>RWAWF6012-</b> ( )(1/2/3)	1,192.	1,370.	1,852.
	20"	66"	24"	<b>RWAWF6612-</b> ( )(1/2/3)	1,227.	1,411.	1,905.
	20"	72"	24"	<b>RWAWF7212-</b> ( )(1/2/3)	1,286.	1,480.	1,998.
Wave transition top with waterfall edge front only (left 24", right 20") 	24"	42"	20"	<b>RWAWF4221-</b> ( )(1/2/3)	990.	1,141.	1,541.
	24"	48"	20"	<b>RWAWF4821-</b> ( )(1/2/3)	1,042.	1,198.	1,618.
	24"	54"	20"	<b>RWAWF5421-</b> ( )(1/2/3)	1,116.	1,282.	1,731.
	24"	60"	20"	<b>RWAWF6021-</b> ( )(1/2/3)	1,192.	1,370.	1,852.
	24"	66"	20"	<b>RWAWF6621-</b> ( )(1/2/3)	1,227.	1,411.	1,905.
	24"	72"	20"	<b>RWAWF7221-</b> ( )(1/2/3)	1,286.	1,480.	1,998.
Wave end top with waterfall edge front (right 20") 	32"	36"	20"	<b>RWEAWF3631-</b> ( )(1/2/3)	1,317.	1,510.	2,040.
	32"	42"	20"	<b>RWEAWF4231-</b> ( )(1/2/3)	1,368.	1,576.	2,127.
	32"	48"	20"	<b>RWEAWF4831-</b> ( )(1/2/3)	1,443.	1,661.	2,241.

Worksurfaces

Order Code	Specification Information	Application Notes
Example: <b>RWAWF4221F2</b>	<i>To order please specify pattern number including:</i>	32"D wave end top requires 20"D end panel for freestanding support.
<b>R</b> Reff	1. Grommet option	36"D wave end top requires 24"D end panel for support.
<b>W</b> Wave top transition	2. Top finish type	Products on this page are shipped without hardware which must be ordered separately from the support components section.
<b>A</b> 1 1/4" thick	3. Top finish	Curvilinear worksurfaces only available in 1 1/4" thick.
<b>WF</b> Waterfall front	4. Grommet finish	See Planning Guide for grommet locations.
<b>42</b> 42" wide	<i>1. Grommet options:</i>	Waterfall tops cannot be specified with semi-open pore finish.
<b>2</b> 24" deep on left side	N = No grommet	
<b>1</b> 20" deep on left side	F = Flush front grommet location	
<b>F</b> Flush grommet location	<i>2. Finish type:</i>	
<b>2</b> V2 finish	1 = V1	
<b>V319</b> Medium cherry	2 = V2	
<b>111</b> Jet Black (grommet)	3 = V3	
	Applicable finishes are listed on page 5 and 6.	
	Products on this page do not accept the following finishes: Y341 Wenge Y342 Medium Teak Y343 Dark Grey Oak	

**Knoll assumes no responsibility for special grommet locations which interfere with support or other hardware.**

Worksurface stiffeners are recommended to provide additional support for open spans greater than 48" w.

Waterfall worksurfaces should be specified in a configuration only with other waterfall worksurfaces.

Actual widths of worksurface are 1/16" less than nominal dimension. Actual depth is 1/8" less than nominal dimension.

# Waterfall Edge 1 1/4"

## 2" Waterfall edge front only curvilinear transition and end tops

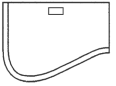
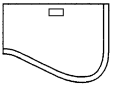
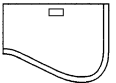
description	d left	w	d right	pattern no.	V1	V2	V3
Wave end top with waterfall edge front (right 24") 	36"	36"	24"	<b>RWEAWF3662-( )(1/2/3)</b>	\$1,360.	\$1,564.	\$2,112.
	36"	42"	24"	<b>RWEAWF4262-( )(1/2/3)</b>	1,404.	1,616.	2,181.
	36"	48"	24"	<b>RWEAWF4862-( )(1/2/3)</b>	1,491.	1,713.	2,312.
Wave end top with waterfall edge front (left 20") 	20"	36"	32"	<b>RWEAWF3613-( )(1/2/3)</b>	1,317.	1,510.	2,040.
	20"	42"	32"	<b>RWEAWF4213-( )(1/2/3)</b>	1,368.	1,576.	2,127.
	20"	48"	32"	<b>RWEAWF4813-( )(1/2/3)</b>	1,443.	1,661.	2,241.
Wave end top with waterfall edge front (left 24") 	24"	36"	36"	<b>RWEAWF3626-( )(1/2/3)</b>	1,360.	1,564.	2,112.
	24"	42"	36"	<b>RWEAWF4226-( )(1/2/3)</b>	1,404.	1,616.	2,181.
	24"	48"	36"	<b>RWEAWF4826-( )(1/2/3)</b>	1,491.	1,713.	2,312.

Order Code	Specification Information	Application Notes
Example: <b>RWAWF4221F2</b>	<i>To order please specify pattern number including:</i>	32"D wave end top requires 20"D end panel for freestanding support.
<b>R</b> Reff		
<b>W</b> Wave top transition	1. Grommet option	36"D wave end top requires 24"D end panel for support.
<b>A</b> 1 1/4" thick	2. Top finish type	
<b>WF</b> Waterfall front	3. Top finish	
<b>42</b> 42" wide	4. Grommet finish	Products on this page are shipped without hardware which must be ordered separately from the support components section.
<b>2</b> 24" deep on left side	<i>1. Grommet options:</i>	Curvilinear worksurfaces only available in 1 1/4" thick.
<b>1</b> 20" deep on left side	N = No grommet	See Planning Guide for grommet locations.
<b>F</b> Flush grommet location	F = Flush front grommet location	Waterfall tops cannot be specified with semi-open pore finish.
<b>2</b> V2 finish		
<b>V319</b> Medium cherry	2. <i>Finish type:</i>	
<b>111</b> Jet Black (grommet)	1 = V1	
	2 = V2	
	3 = V3	
	Applicable finishes are listed on page 5 and 6.	
	Products on this page do not accept the following finishes: Y341 Wenge Y342 Medium Teak Y343 Dark Grey Oak	

**Knoll assumes no responsibility for special grommet locations which interfere with support or other hardware.**

Worksurface stiffeners are recommended to provide additional support for open spans greater than 48" w.

Waterfall worksurfaces should be specified in a configuration only with other waterfall worksurfaces.

Actual widths of worksurface are 1/16" less than nominal dimension. Actual depth is 1/8" less than nominal dimension.

# Waterfall Edge 1 1/4"

## 2" Waterfall edge front only curvilinear corner tops

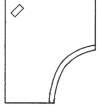
description	Back w	w	pattern no.	V1	V2	V3
Curved corner work top, with waterfall edge front only (both returns 20") 	36"	36"	<b>RCAWF363611-( ) (1/2/3)</b>	\$1,564.	\$1,801.	\$2,430.
	36"	42"	<b>RCAWF364211-( ) (1/2/3)</b>	1,656.	1,904.	2,572.
	36"	48"	<b>RCAWF364811-( ) (1/2/3)</b>	1,757.	2,021.	2,730.
	42"	36"	<b>RCAWF423611-( ) (1/2/3)</b>	1,656.	1,904.	2,572.
	42"	42"	<b>RCAWF424211-( ) (1/2/3)</b>	1,757.	2,021.	2,730.
	42"	48"	<b>RCAWF424811-( ) (1/2/3)</b>	1,919.	2,208.	2,981.
	48"	36"	<b>RCAWF483611-( ) (1/2/3)</b>	1,757.	2,021.	2,730.
	48"	42"	<b>RCAWF484211-( ) (1/2/3)</b>	1,919.	2,208.	2,981.
<i>Radii of front edge varies with top dimensions</i>						
Curved corner work top, with waterfall edge front only (both returns 24")	36"	36"	<b>RCAWF363622-( ) (1/2/3)</b>	1,772.	2,042.	2,757.
	36"	42"	<b>RCAWF364222-( ) (1/2/3)</b>	1,863.	2,148.	2,899.
	36"	48"	<b>RCAWF364822-( ) (1/2/3)</b>	1,966.	2,263.	3,055.
	42"	36"	<b>RCAWF423622-( ) (1/2/3)</b>	1,863.	2,148.	2,899.
	42"	42"	<b>RCAWF424222-( ) (1/2/3)</b>	1,966.	2,263.	3,055.
	42"	48"	<b>RCAWF424822-( ) (1/2/3)</b>	2,129.	2,451.	3,308.
	48"	36"	<b>RCAWF483622-( ) (1/2/3)</b>	1,966.	2,263.	3,055.
	48"	42"	<b>RCAWF484222-( ) (1/2/3)</b>	2,129.	2,451.	3,308.
Curved corner work top, with waterfall edge front only (left return 20", right return 24")	36"	36"	<b>RCAWF363612-( ) (1/2/3)</b>	1,634.	1,879.	2,536.
	36"	42"	<b>RCAWF364212-( ) (1/2/3)</b>	1,729.	1,985.	2,680.
	36"	48"	<b>RCAWF364812-( ) (1/2/3)</b>	1,828.	2,102.	2,838.
	42"	36"	<b>RCAWF423612-( ) (1/2/3)</b>	1,729.	1,985.	2,680.
	42"	42"	<b>RCAWF424212-( ) (1/2/3)</b>	1,828.	2,102.	2,838.
	42"	48"	<b>RCAWF424812-( ) (1/2/3)</b>	1,990.	2,287.	3,087.
	48"	36"	<b>RCAWF483612-( ) (1/2/3)</b>	1,828.	2,102.	2,838.
	48"	42"	<b>RCAWF484212-( ) (1/2/3)</b>	1,990.	2,287.	3,087.
Curved corner work top, with waterfall edge front only (left return 24", right return 20")	36"	36"	<b>RCAWF363621-( ) (1/2/3)</b>	1,634.	1,879.	2,536.
	36"	42"	<b>RCAWF364221-( ) (1/2/3)</b>	1,729.	1,985.	2,680.
	36"	48"	<b>RCAWF364821-( ) (1/2/3)</b>	1,828.	2,102.	2,838.
	42"	36"	<b>RCAWF423621-( ) (1/2/3)</b>	1,729.	1,985.	2,680.
	42"	42"	<b>RCAWF424221-( ) (1/2/3)</b>	1,828.	2,102.	2,838.
	42"	48"	<b>RCAWF424821-( ) (1/2/3)</b>	1,990.	2,287.	3,087.
	48"	36"	<b>RCAWF483621-( ) (1/2/3)</b>	1,828.	2,102.	2,838.
	48"	42"	<b>RCAWF484221-( ) (1/2/3)</b>	1,990.	2,287.	3,087.

Order Code	Specification Information	Application Notes
Example: <b>RCAWF363611F2</b> <b>R</b> Reff <b>C</b> Curved front corner <b>A</b> 1 1/4" thick <b>WF</b> Waterfall front <b>36</b> 36" wide on left back <b>36</b> 36" wide on right back <b>1</b> 20" deep on left side <b>1</b> 20" deep on right side <b>F</b> Standard grommet <b>2</b> V2 finish <b>V319</b> Medium cherry <b>111</b> Jet Black (grommet)	To order please specify pattern number including: 1. Grommet option 2. Top finish type 3. Top finish 4. Grommet finish  1. Grommet options: N = No grommet F = Standard corner location or Flush  2. Finish type: 1 = V1 2 = V2 3 = V3	Radius of curved front changes with overall top size. See Planning Guide.  Products on this page are shipped without hardware which must be ordered separately from the support components section.  Curvilinear worksurfaces only available in 1 1/4" thick.  See Planning Guide for grommet locations.

Waterfall tops cannot be specified with semi-open pore finish.

**Knoll assumes no responsibility for special grommet locations which interfere with support or other hardware.**

Waterfall worksurfaces should be specified in a configuration only with other waterfall worksurfaces.

Actual widths of worksurface are 1/16" less than nominal dimension. Actual depth is 1/8" less than nominal dimension.



Applicable finishes are listed on page 5 and 6.

Products on this page do not accept the following finishes:  
 Y341 Wenge  
 Y342 Medium Teak  
 Y343 Dark Grey Oak

# Waterfall Edge 1 1/4"

## 2" Waterfall edge meeting tops

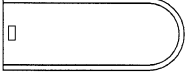
Reff Profiles



description	d	w	pattern no.	V1	V2	V3
Peninsula D-shaped tops Waterfall edge on all except flat side 	30"	42"	<b>RMDAWF4230-( )(1/2/3)</b>	\$1,998.	\$2,299.	\$3,102.
		48"	<b>RMDAWF4830-( )(1/2/3)</b>	2,155.	2,478.	3,345.
		54"	<b>RMDAWF5430-( )(1/2/3)</b>	2,313.	2,660.	3,592.
		60"	<b>RMDAWF6030-( )(1/2/3)</b>	2,472.	2,842.	3,835.
		66"	<b>RMDAWF6630-( )(1/2/3)</b>	2,632.	3,028.	4,088.
		72"	<b>RMDAWF7230-( )(1/2/3)</b>	2,794.	3,215.	4,339.
		78"	<b>RMDAWF7830-( )(1/2/3)</b>	3,164.	3,633.	4,907.
		84"	<b>RMDAWF8430-( )(1/2/3)</b>	3,530.	4,058.	5,479.
		90"	<b>RMDAWF9030-( )(1/2/3)</b>	3,940.	4,531.	6,117.
	96"	<b>RMDAWF9630-( )(1/2/3)</b>	4,350.	5,001.	6,751.	
	36"	42"	<b>RMDAWF4236-( )(1/2/3)</b>	2,204.	2,532.	3,417.
		48"	<b>RMDAWF4836-( )(1/2/3)</b>	2,408.	2,769.	3,739.
		54"	<b>RMDAWF5436-( )(1/2/3)</b>	2,751.	3,168.	4,276.
		60"	<b>RMDAWF6036-( )(1/2/3)</b>	3,088.	3,551.	4,795.
		66"	<b>RMDAWF6636-( )(1/2/3)</b>	3,142.	3,615.	4,880.
		72"	<b>RMDAWF7236-( )(1/2/3)</b>	3,194.	3,674.	4,960.
		78"	<b>RMDAWF7836-( )(1/2/3)</b>	3,595.	4,135.	5,579.
		84"	<b>RMDAWF8436-( )(1/2/3)</b>	4,001.	4,600.	6,210.
		90"	<b>RMDAWF9036-( )(1/2/3)</b>	4,215.	4,852.	6,548.
Wrap around panel top 	21 1/2"	42 1/2"	<b>RMDAWF4221-( )(1/2/3)( )</b>	2,572.	2,955.	3,989.
	25 1/2"	50 1/2"	<b>RMDAWF5025-( )(1/2/3)( )</b>	2,818.	3,241.	4,375.

\*specify mating end trim profile

Order Code	Specification Information	Application Notes
Example: <b>RMDAWF4230N2</b>	<i>To order please specify pattern number including:</i>	See Planning Guide for standard grommet locations. D-top grommet location is always centered at flat end.
<b>R</b> Reff	1. Top thickness	<b>Knoll assumes no responsibility for special grommet locations which interfere with support or other hardware.</b>
<b>MD</b> Meeting D-shaped top	2. Grommet option	
<b>A</b> 1 1/4" thick	3. Top finish type	Refer to Planning Guide for modesty panel size requirements and all other support options.
<b>WF</b> Waterfall all except flat side	4. Top finish	
<b>42</b> 42" wide	5. Grommet finish	Waterfall tops cannot be specified with semi-open pore finish.
<b>30</b> 30" deep	1. <i>Thickness option:</i> A = 1 1/4"	
<b>N</b> No grommet	2. <i>Grommet options:</i> N = No grommet	Peninsula D-shaped top has grommet choice centered (as shown) or none. No grommet option on P or 9 tops.
<b>2</b> V2 finish	F = Flush front grommet location R = Recessed front C = Centered (only on D-tops)	
<b>V319</b> Medium cherry	3. <i>Finish type:</i> 1 = V1 2 = V2 3 = V3	Actual widths of worksurface are 1/16" less than nominal dimension. Actual depth is 1/8" less than nominal dimension.
	Note wrap around panel tops only, require specification of mating trim profile.	
	A = Flat B = Square C = Bullnose E = Extruded Aluminum	Applicable finishes are listed on page 5 and 6.
		Products on this page do not accept the following finishes: Y341 Wenge Y342 Medium Teak Y343 Dark Grey Oak

# Waterfall Edge 1 1/4"

## 2" Waterfall edge meeting tops P and 9

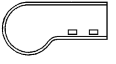
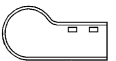
description	d	w	pattern no.	V1	V2	V3
Meeting P-top (adjoining top must use 12" end panel and modesty panel to support)	30"	42"	<b>RMPAWF4230-( )(1/2/3)</b>	\$2,747.	\$3,157.	\$4,262.
						
Meeting 9-top (adjoining top must use 12" end panel and modesty panel to support)	30"	42"	<b>RM9AWF4230-( )(1/2/3)</b>	2,747.	3,157.	4,262.
						
Worksurface 9-top	30"	84"	<b>RM9AWF8430-( )(1/2/3)</b>	5,588.	6,427.	8,676.
	30"	96"	<b>RM9AWF9630-( )(1/2/3)</b>	5,823.	6,692.	9,035.
Worksurface P-top	30"	84"	<b>RMPAWF8430-( )(1/2/3)</b>	5,588.	6,427.	8,676.
	30"	96"	<b>RMPAWF9630-( )(1/2/3)</b>	5,823.	6,692.	9,035.

Worksurfaces

Order Code	Specification Information	Application Notes
Example: <b>RM9AWF8430N2</b>	<i>To order please specify pattern number including:</i>	See Planning Guide for standard grommet locations. D-top grommet location is always centered at flat end.
<b>R</b> Reff	1. Top thickness	Products on this page are shipped without hardware which must be ordered separately from the support components section.
<b>M9</b> Meeting 9-shaped top	2. Grommet option	Worksurface stiffeners are recommended to provide additional support for open spans greater than 48"w.
<b>A</b> 1 1/4" thick	3. Top finish type	Waterfall worksurfaces should be specified in a configuration only with other waterfall worksurfaces.
<b>WF</b> Waterfall all except flat side	4. Top finish	Actual widths of worksurface are 1/16" less than nominal dimension. Actual depth is 1/8" less than nominal dimension.
<b>84</b> 84" wide	5. Grommet finish	Applicable finishes are listed on page 5 and 6.
<b>30</b> 30" deep	<i>1. Thickness option:</i> A = 1 1/4"	Products on this page do not accept the following finishes: Y341 Wenge Y342 Medium Teak Y343 Dark Grey Oak
<b>N</b> No grommet	<i>2. Grommet options:</i> N = No grommet F = Flush front grommet location R = Recessed front C = Centered (only on D-tops)	
<b>2</b> V2 finish	<i>3. Finish type:</i> 1 = V1 2 = V2 3 = V3	
<b>V319</b> Medium cherry	Note wrap around panel tops only, require specification of mating trim profile.	

# Waterfall Edge 1 1/4"

## 2" Waterfall edge bow front tops

description	w	d	h	pattern no.	L	V1	V2	V3
 30"D	72"	30"		<b>RMBAWA7230-( )(1/2/3)</b>		\$2,771.	\$3,191.	\$4,308.
	84"	30"		<b>RMBAWA8430-( )(1/2/3)</b>		3,059.	3,519.	4,749.
	96"	30"		<b>RMBAWA9630-( )(1/2/3)</b>		3,394.	3,902.	5,269.

Use 29" deep pedestals or end panels.  
**Do not** use 23" deep pedestals if using recessed modesty.

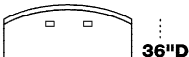
 36"D	72"	36"		<b>RMBAWA7236-( )(1/2/3)</b>		2,948.	3,390.	4,575.
	84"	36"		<b>RMBAWA8436-( )(1/2/3)</b>		3,235.	3,720.	5,021.
	96"	36"		<b>RMBAWA9636-( )(1/2/3)</b>		3,588.	4,121.	5,564.

Use 29" deep end panels or 29" deep pedestals (this will provide a cantilevered appearance).  
 Can also be used with 36" deep end panel and recessed modesty.

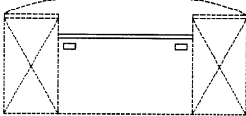
Short modesty panel	w	d	h	pattern no.	L	V1	V2	V3
	40"	1"	26 1/2"	<b>RB40MR-( )</b>	322.	415.	475.	642.
	52"	1"	26 1/2"	<b>RB52MR-( )</b>	379.	488.	561.	758.
	64"	1"	26 1/2"	<b>RB64MR-( )</b>	410.	525.	607.	820.

**Use of short modesty panel**

Pedestals must be ordered separately with individual back panels.  
 Short modesty comes with attachment brackets to secure modesty panel to sides of pedestals.  
 Order:  
 40" modesty for 72" bow top  
 52" modesty for 84" bow top  
 64" modesty for 96" bow top  
 When ordering bow top 30"D for use with short modesty, specify recessed grommet location.  
 When ordering bow top 36"D for use with short modesty, specify alternate grommet location.

Order Code	Specification Information	Application Notes
Example: <b>RMBAWA7230(F)2</b>	<i>To order please specify pattern number including:</i>	See Planning Guide for grommet locations.
<b>R</b> Reff	1. Grommet option	Shipped with hardware. Refer to page 0 of planning guide for application details.
<b>MB</b> Bow front with Waterfall edge	2. Top finish type	*Grommet options for elliptical tops are Recessed (R) or None (N).
<b>A</b> 1 1/4" thick	3. Top finish	Worksurface stiffeners are recommended to provide additional support for open spans greater than 48" w.
<b>WA</b> Waterfall front/back	4. Grommet finish	<b>Knoll assumes no responsibility for special grommet locations which interfere with support or other hardware.</b>
<b>72</b> 72" wide	<i>1. Grommet options:</i>	Shipped with hardware. Refer to page 0 of planning guide for application details.
<b>30</b> 30" deep	N = No grommet	Waterfall tops cannot be specified with semi-open pore finish.
<b>F</b> Flush front grommet position	F = Flush front grommet location	Alternate grommet location is to position grommets behind short modesty panel, when it is used with 36"D bowed top.
<b>2</b> V2 finish	R = Recessed front	Waterfall worksurfaces should be specified in a configuration only with other waterfall worksurfaces.
<b>V319</b> Medium cherry	A = Alternate location (for 36"D tops only)	Actual widths of worksurface are 1/16" less than nominal dimension. Actual depth is 1/8" less than nominal dimension.
<b>111</b> Jet Black (grommet)	2. <i>Finish type:</i>	
	1 = V1	
	2 = V2	
	3 = V3	

Applicable finishes are listed on page 5 and 6.

Products on this page do not accept the following finishes:  
 Y341 Wenge  
 Y342 Medium Teak  
 Y343 Dark Grey Oak



# Waterfall Edge 1 1/4"

## *Waterfall elliptical tops and bulkhead*

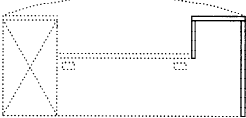
description	w	d	h	pattern no.	L	V1	V2	V3
Waterfall elliptical tops 	60"	30"		<b>REBAWA6030( )</b>		\$3,916.	\$4,501.	\$6,078.
	72"	42"		<b>REBAWA7242( )</b>		5,566.	6,405.	8,647.
	78"	48"		<b>REBAWA7848( )</b>		6,108.	7,026.	9,486.
Bulkhead (false pedestal)* 	16"	24"	26 1/2"	<b>REBH24</b>	454.	686.	795.	1,073.
	16"	30"	26 1/2"	<b>REBH30</b>	470.	699.	815.	1,099.

Worksurfaces

Order Code	Specification Information	Application Notes
Example: <b>REBAWA6030</b>	<i>To order please specify pattern number including:</i>	See Planning Guide for grommet locations.
<b>R</b> Reff		
<b>EB</b> Elliptical Waterfall	1. Grommet option	*Grommet options for elliptical tops are Recessed (R) or None (N).
<b>A</b> 1 1/4" thick	2. Top finish type	
<b>WA</b> Waterfall front/back	3. Top finish	Worksurface stiffeners are recommended to provide additional support for open spans greater than 48" w.
<b>60</b> 60" wide	4. Grommet finish	
<b>30</b> 30" deep	<i>1. Grommet options:</i>	<b>Knoll assumes no responsibility for special grommet locations which interfere with support or other hardware.</b>
<b>F</b> Flush front grommet position	N = No grommet	
<b>2</b> V2 finish	F = Flush front grommet location	
<b>V319</b> Medium cherry	R = Recessed front	
<b>111</b> Jet Black (grommet)	A = Alternate location (for 36"D tops only)	
	<i>2. Finish type:</i>	
	1 = V1	*Bulkhead takes the place of a pedestal in applications using short modesty panel, but not requiring a double pedestal application.
	2 = V2	
	3 = V3	

Applicable finishes are listed on page 5 and 6.

Products on this page do not accept the following finishes:  
 Y341 Wenge  
 Y342 Medium Teak  
 Y343 Dark Grey Oak

# Waterfall Edge 1 1/4"

## 2" Waterfall edge conference room tops round and racetrack



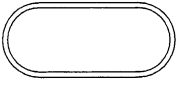
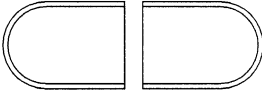
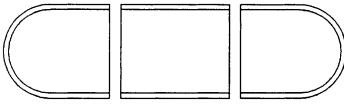
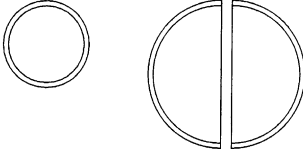

Reff Profiles

description	w	d	pattern no.	V1	V2	V3
Racetrack top - one piece 	72"	30"	<b>RTAW7230-(1/2/3)</b>	\$3,916.	\$4,501.	\$6,078.
	72"	36"	<b>RTAW7236-(1/2/3)</b>	4,463.	5,130.	6,925.
	84"	30"	<b>RTAW8430-(1/2/3)</b>	4,358.	5,012.	6,767.
	84"	36"	<b>RTAW8436-(1/2/3)</b>	5,017.	5,770.	7,787.
	84"	42"	<b>RTAW8442-(1/2/3)</b>	6,108.	7,026.	9,486.
	96"	30"	<b>RTAW9630-(1/2/3)</b>	4,852.	5,578.	7,532.
	96"	36"	<b>RTAW9636-(1/2/3)</b>	5,566.	6,405.	8,647.
Racetrack top - two piece, Waterfall edge on all sides except on parting lines 	120"	36"	<b>RTAW12036-(1/2/3)</b>	7,191.	8,267.	11,162.
	120"	42"	<b>RTAW12042-(1/2/3)</b>	7,754.	8,915.	12,037.
	144"	42"	<b>RTAW14442-(1/2/3)</b>	8,550.	9,832.	13,274.
Racetrack top - three piece, Waterfall edge on all sides except on parting lines 	168"	42"	<b>RTAW16842-(1/2/3)</b>	10,721.	12,331.	16,647.
	192"	42"	<b>RTAW19242-(1/2/3)</b>	11,518.	13,248.	17,886.
			RTAW16842-(1/2) comes with 2-60" pieces/1-48" center RTAW19242-(1/2) comes with 2-72" pieces/1-48" center			
Round tops, Waterfall edge on all sides except on parting lines 	*	60"	<b>RTAW6060-(1/2/3)</b>	6,590.	7,574.	10,226.
	*	72"	<b>RTAW7272-(1/2/3)</b>	8,156.	9,378.	12,660.
	-	36"	<b>RTAW3636-(1/2/3)</b>	2,204.	2,954.	3,988.
	-	42"	<b>RTAW4242-(1/2/3)</b>	2,551.	3,423.	4,622.

Order Code	Specification Information	Application Notes
Example: <b>RTAW72302</b>	<i>To order please specify pattern number including:</i>	Top to top brackets included.
<b>R</b> Reff	1. Top thickness	Actual widths of worksurface are 1/16" less than nominal dimension. Actual depth is 1/8" less than nominal dimension.
<b>T</b> Rounded top	2. Finish type	See table base matrix in Planning Guide for base supports recommended.
<b>A</b> 1 1/4" thick	3. Finish	Worksurface stiffeners are recommended to provide additional support for open spans greater than 48" w.
<b>W</b> Waterfall all sides	1. <i>Thickness option:</i> A = 1 1/4"	Applicable finishes are listed on page 5 and 6.
<b>72</b> 72" wide	2. <i>Finish type:</i> 1 = V1	Products on this page do not accept the following finishes: Y341 Wenge
<b>30</b> 30" deep	2 = V2	Y342 Medium Teak
<b>2</b> V2 finish	3 = V3	Y343 Dark Grey Oak
<b>V319</b> Medium cherry	*Round tops in two pieces.	Tops have no radius on edges that adjoin.  All tops on this page are without grommets or drillings. The intended use of these products is to provide conference room table options.  Waterfall tops cannot be specified with semi-open pore finish.

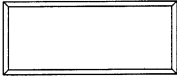
# Waterfall Edge 1 1/4"

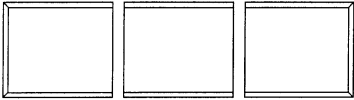
## 2" Waterfall edge conference room tops square and rectangular

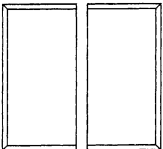
description	w	d	pattern no.	V1	V2	V3
Rectangular top - one piece 	72"	30"	<b>RRAW7230-(1/2/3)</b>	\$2,067.	\$2,380.	\$3,214.
	72"	36"	<b>RRAW7236-(1/2/3)</b>	2,247.	2,584.	3,488.
	84"	30"	<b>RRAW8430-(1/2/3)</b>	2,287.	2,632.	3,553.
	84"	36"	<b>RRAW8436-(1/2/3)</b>	2,458.	2,823.	3,812.
	84"	42"	<b>RRAW8442-(1/2/3)</b>	3,633.	4,176.	5,639.
	96"	30"	<b>RRAW9630-(1/2/3)</b>	2,566.	2,952.	3,985.
	96"	42"	<b>RRAW9642-(1/2/3)</b>	4,166.	4,791.	6,468.
Rectangular top - two piece, Waterfall edge on all sides except on parting lines 	120"	36"	<b>RRAW12036-(1/2/3)</b>	4,545.	5,232.	7,063.
	120"	42"	<b>RRAW12042-(1/2/3)</b>	6,274.	7,216.	9,742.
	144"	42"	<b>RRAW14442-(1/2/3)</b>	7,048.	8,106.	10,942.
Rectangular top - three piece, Waterfall edge on all sides except on parting lines 	168"	42"	<b>RRAW16842-(1/2/3)</b>	9,241.	10,630.	14,353.
	192"	42"	<b>RRAW19242-(1/2/3)</b>	10,014.	11,514.	15,545.
RRAW16842-(1/2) comes with 2-60" pieces/1-48" center RRAW19242-(1/2) comes with 2-72" pieces/1-48" center						
Square top - one piece 	-	36"	<b>RRAW3636-(1/2/3)</b>	1,599.	2,142.	2,894.
	-	42"	<b>RRAW4242-(1/2/3)</b>	2,067.	2,774.	3,745.
Square top - two piece, Waterfall edge not on parting lines 	-	60"	<b>RRAW6060-(1/2/3)</b>	4,235.	4,868.	6,572.
	-	72"	<b>RRAW7272-(1/2/3)</b>	5,001.	5,752.	7,764.

Order Code	Specification Information	Application Notes
Example: <b>RRAW72302</b> <b>R</b> Reff <b>R</b> Rectangular <b>A</b> 1 1/4" thick <b>W</b> Waterfall all sides <b>72</b> 72" wide <b>30</b> 30" deep <b>2</b> V2 finish <b>V319</b> Medium cherry	To order please specify pattern number including: 1. Top thickness 2. Finish type 3. Finish  1. Thickness option: A = 1 1/4"  2. Finish type: 1 = V1 2 = V2 3 = V3  Applicable finishes are listed on page 5 and 6.  Products on this page do not accept the following finishes: Y341 Wenge Y342 Medium Teak Y343 Dark Grey Oak	All tops on this page are without grommets or drillings. The intended use of these products is to provide conference room table options.  Top to top brackets included.  Tops have no radius on edges that adjoin.  See table base matrix in Planning Guide for base supports recommended.  Worksurface stiffeners are recommended to provide additional support for open spans greater than 48" w.  Waterfall tops cannot be specified with semi-open pore finish.

# Cascade Edge 1 1/4" Rectilinear 24" and 30" deep

Reff Profiles

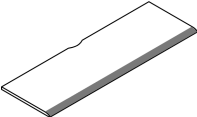
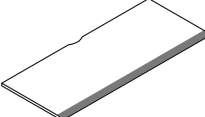
description	d	w	pattern no.	Woodgrain	Solid
24"D Rectangular  <i>shown with grommet</i>	24"	24"	<b>RCE1R2424N</b>	\$240.	\$209.
	24"	30"	<b>RCE1R3024N</b>	276.	240.
	24"	36"	<b>RCE1R3624N</b>	306.	265.
	24"	42"	<b>RCE1R4224N</b>	352.	306.
	24"	48"	<b>RCE1R4824N</b>	395.	343.
	24"	54"	<b>RCE1R5424N</b>	424.	369.
	24"	60"	<b>RCE1R6024N</b>	460.	400.
	24"	66"	<b>RCE1R6624N</b>	496.	432.
	24"	72"	<b>RCE1R7224N</b>	520.	452.
	24"	78"	<b>RCE1R7824N</b>	557.	485.
	24"	84"	<b>RCE1R8424N</b>	589.	513.
	24"	90"	<b>RCE1R9024N</b>	664.	578.
24"	96"	<b>RCE1R9624N</b>	725.	631.	
30"D Rectangular  <i>shown with grommet</i>	30"	24"	<b>RCE1R2430N</b>	307.	266.
	30"	30"	<b>RCE1R3030N</b>	343.	299.
	30"	36"	<b>RCE1R3630N</b>	382.	332.
	30"	42"	<b>RCE1R4230N</b>	414.	361.
	30"	48"	<b>RCE1R4830N</b>	460.	400.
	30"	54"	<b>RCE1R5430N</b>	521.	453.
	30"	60"	<b>RCE1R6030N</b>	572.	498.
	30"	66"	<b>RCE1R6630N</b>	638.	555.
	30"	72"	<b>RCE1R7230N</b>	664.	578.
	30"	78"	<b>RCE1R7830N</b>	709.	617.
	30"	84"	<b>RCE1R8430N</b>	754.	656.
	30"	90"	<b>RCE1R9030N</b>	811.	705.
30"	96"	<b>RCE1R9630N</b>	867.	754.	

Order Code	Specification Information	Application Notes
Example: <b>RCE1R3024N 118</b>	<i>To order please specify pattern number including finish:</i>	Center-located edge grommet.
<b>R</b> Reff	<i>Available finishes:</i>	To specify grommet, replace the "N" suffix in pattern number with "G". Add \$20.
<b>CE1</b> Cascade edge	<i>Solid:</i>	All support hardware ordered separately.
<b>R</b> Rectangular	114 Folkstone Grey	Worksurface stiffeners are recommended to provide additional support for open spans greater than 48" w.
<b>30</b> Width	117 Soft Grey	Specify cantilever bracket (ASBC18(L/R) or ASBC24(L/R)) from page 0-109 as required to support Cascade edge worksurfaces for Reff panel hung applications.
<b>24</b> Depth	118 Bright White	Cascade edge worksurfaces are not recommended for free-standing applications.
<b>N</b> No grommet	119 Pumice	Actual width 1/16" less nominal. Actual depth 3/8" less nominal for cord drop.
<b>118</b> Finish	<i>Woodgrain:</i>	Please Note: Cascade Edge worksurfaces are wrapped with a PVC-free, 3D laminate sheet that is heated and pressed around an FSC certified substrate. 3D laminate is more susceptible to denting, impact, tearing and marring than conventional high pressure laminate and should be handled with care. Do not drag worksurfaces across any flooring surface. Treat Cascade Edge worksurfaces like veneer worksurfaces for optimum performance under normal conditions. Cascade Edge worksurfaces come with a 10 year warranty that covers defects in workmanship and materials. This warranty does not cover damage occurring during or after installation.
	124 Medium Cherry	
	125 Natural Maple	
	126 Natural Cherry	
	127 Walnut	

# Cascade Edge 1 1/4" Blended "D"

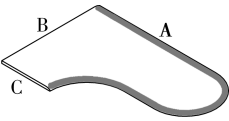
description	A	B	C	pattern no.	Woodgrain	Solid
 <p>right hand shown</p>	48"	24"	66"	<b>RCE1BD6648S(L/R)</b>	\$973.	\$846.
	48"	24"	72"	<b>RCE1BD7248S(L/R)</b>	996.	865.
	48"	24"	78"	<b>RCE1BD7848S(L/R)</b>	1,149.	999.
	48"	24"	84"	<b>RCE1BD8448S(L/R)</b>	1,180.	1,026.
	48"	30"	66"	<b>RCE1BD6648D(L/R)</b>	1,024.	889.
	48"	30"	72"	<b>RCE1BD7248D(L/R)</b>	1,061.	922.
	48"	30"	78"	<b>RCE1BD7848D(L/R)</b>	1,187.	1,033.
	48"	30"	84"	<b>RCE1BD8448D(L/R)</b>	1,254.	1,091.

Order Code	Specification Information	Application Notes
Example: <b>RCE1BD6648SR 118</b>	<i>To order please specify pattern number including:</i>	All support hardware ordered separately.
<b>R</b> Reff		
<b>CE1</b> Cascade edge	1. Return depth (dimension C on line art, hard coded in pattern number )	Worksurface stiffeners are recommended to provide additional support for open spans greater than 48" w.
<b>BD</b> Blended "D"	S = 24" return	
<b>66</b> Width	D = 30" return	Specify cantilever bracket (ASBC18(L/R) or ASBC24(L/R)) from page 0-109 as required to support Cascade edge worksurfaces for Reff panel hung applications.
<b>48</b> Depth		Cascade edge worksurfaces are not recommended for free-standing applications.
<b>S</b> 24" return		Actual width 1/16" less nominal. Actual depth 3/8" less nominal for cord drop.
<b>R</b> right hand	2. Hand ( left or right )	
<b>118</b> Finish	3. Finish	
	<i>Solid:</i>	
	114 Folkstone Grey	
	117 Soft Grey	
	118 Bright White	
	119 Pumice	
	Woodgrain:	
	124 Medium Cherry	
	125 Natural Maple	
	126 Natural Cherry	
	127 Walnut	
		Please Note: Cascade Edge worksurfaces are wrapped with a PVC-free, 3D laminate sheet that is heated and pressed around an FSC certified substrate. 3D laminate is more susceptible to denting, impact, tearing and marring than conventional high pressure laminate and should be handled with care. Do not drag worksurfaces across any flooring surface. Treat Cascade Edge worksurfaces like veneer worksurfaces for optimum performance under normal conditions. Cascade Edge worksurfaces come with a 10 year warranty that covers defects in workmanship and materials. This warranty does not cover damage occurring during or after installation.

# Cascade Edge 1 1/4"

## Curvilinear corner

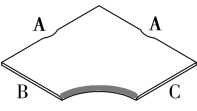
description	A	B	C	pattern no.	Woodgrain	Solid
Curvilinear corner	24"	24"	36"	<b>RCE1L3636SSN</b>	\$602.	\$523.
 <p>shown with grommets</p>	24"	24"	42"	<b>RCE1L4242SSN</b>	725.	631.
	24"	24"	48"	<b>RCE1L4848SSN</b>	816.	709.
	24"	30"	42"	<b>RCE1L4242DSN</b>	861.	750.
	24"	30"	48"	<b>RCE1L4848DSN</b>	976.	849.
	30"	24"	42"	<b>RCE1L4242SDN</b>	861.	750.
	30"	24"	48"	<b>RCE1L4848SDN</b>	976.	849.
	30"	30"	48"	<b>RCE1L4848DDN</b>	876.	762.

### Order Code

Example: <b>RCE1L3636SSN 114</b>
<b>RCE1</b> Reff Cascade Edge worksurface
<b>L</b> Curvilinear Corner top
<b>36</b> Width
<b>36</b> Depth
<b>S</b> 24" d, left side
<b>S</b> 24" d, right side
<b>N</b> No grommet
<b>114</b> Folkstone Grey finish
Grain Direction

Note: When wood grain or brushed finishes are specified on Cascade corner worksurfaces with two "A" sides of equal length that do not exceed 42" you must select one of three grain direction options. Insert the desired grain direction "L"= Left hand, "R"= Right hand or "D"= Diagonal after the worksurface finish code to indicate the appropriate grain direction. When the "D" option is selected please add \$25.00 to the worksurface list price. 48" Cascade corners are not available with a diagonal grain option.

### Specification Information

To order please specify pattern number including:

- Return depths (hard coded in pattern number)
  - SS = 24" d left and right
  - SD = 24" d left, 30" d right
  - DS = 30" d left, 24" d right
  - DD = 30" d left and right
- Grommets ( hard coded in pattern number )
  - N= no grommets
  - G= grommets

To specify grommets, replace the "N" suffix in pattern number with "G". Add \$40.
- Finish
 

**Solid:**

  - 114 Folkstone Grey
  - 117 Soft Grey
  - 118 Bright White
  - 119 Pumice

Woodgrain:

  - 124 Medium Cherry
  - 125 Natural Maple
  - 126 Natural Cherry
  - 127 Walnut

Graing Direction:

  - D = Diagonal
  - L = Left hand
  - N = Not required
  - R = Right hand

### Application Notes

Center-located edge grommets, located on center of sides marked A.

All support hardware ordered separately.

Worksurface stiffeners are recommended to provide additional support for open spans greater than 48" w.

Specify cantilever bracket (ASBC18 (L/R) or ASBC24 (L/R)) from page 0-109 as required to support Cascade edge worksurfaces for Reff panel hung applications.

Cascade edge worksurfaces are not recommended for free-standing applications.

Actual width 1/16" less nominal.  
Actual depth 3/8" less nominal for cord drop.

Please Note: Cascade Edge worksurfaces are wrapped with a PVC-free, 3D laminate sheet that is heated and pressed around an FSC certified substrate. 3D laminate is more susceptible to denting, impact, tearing and marring than conventional high pressure laminate and should be handled with care. Do not drag worksurfaces across any flooring surface. Treat Cascade Edge worksurfaces like veneer worksurfaces for optimum performance under normal conditions. Cascade Edge worksurfaces come with a 10 year warranty that covers defects in workmanship and materials. This warranty does not cover damage occurring during or after installation.

# Cascade Edge 1 1/4" Blended "L"

Reff Profiles

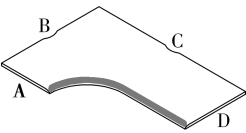



description	B	C	A	D	pattern no.	Woodgrain	Solid
 <p>shown with grommets</p>	42"	60"	24"	24"	<b>RCE1L4260SSN</b>	\$997.	\$867.
	42"	66"	24"	24"	<b>RCE1L4266SSN</b>	1,024.	889.
	42"	72"	24"	24"	<b>RCE1L4272SSN</b>	1,063.	923.
	42"	78"	24"	24"	<b>RCE1L4278SSN</b>	1,073.	934.
	48"	60"	24"	24"	<b>RCE1L4860SSN</b>	1,009.	878.
	48"	60"	24"	30"	<b>RCE1L4860SDN</b>	992.	861.
	48"	60"	30"	24"	<b>RCE1L4860DSN</b>	992.	861.
	48"	66"	24"	24"	<b>RCE1L4866SSN</b>	1,045.	910.
	48"	66"	24"	30"	<b>RCE1L4866SDN</b>	1,042.	906.
	48"	66"	30"	24"	<b>RCE1L4866DSN</b>	1,042.	906.
	48"	72"	24"	24"	<b>RCE1L4872SSN</b>	1,084.	943.
	48"	72"	24"	30"	<b>RCE1L4872SDN</b>	1,091.	948.
	48"	72"	30"	24"	<b>RCE1L4872DSN</b>	1,091.	948.
	48"	78"	24"	24"	<b>RCE1L4878SSN</b>	1,195.	1,039.
	48"	84"	24"	24"	<b>RCE1L4884SSN</b>	1,344.	1,168.
	60"	42"	24"	24"	<b>RCE1L6042SSN</b>	997.	867.
	60"	48"	24"	24"	<b>RCE1L6048SSN</b>	1,009.	878.
	60"	48"	24"	30"	<b>RCE1L6048SDN</b>	992.	861.
	60"	48"	30"	24"	<b>RCE1L6048DSN</b>	992.	861.
	66"	42"	24"	24"	<b>RCE1L6642SSN</b>	1,024.	889.
	66"	48"	24"	24"	<b>RCE1L6648SSN</b>	1,045.	910.
	66"	48"	24"	30"	<b>RCE1L6648SDN</b>	1,042.	906.
	66"	48"	30"	24"	<b>RCE1L6648DSN</b>	1,042.	906.
	72"	42"	24"	24"	<b>RCE1L7242SSN</b>	1,063.	923.
	72"	48"	24"	24"	<b>RCE1L7248SSN</b>	1,084.	943.
	72"	48"	24"	30"	<b>RCE1L7248SDN</b>	1,091.	948.
	72"	48"	30"	24"	<b>RCE1L7248DSN</b>	1,091.	948.
	78"	42"	24"	24"	<b>RCE1L7842SSN</b>	1,073.	934.
	78"	48"	24"	24"	<b>RCE1L7848SSN</b>	1,195.	1,039.
	84"	48"	24"	24"	<b>RCE1L8448SSN</b>	1,344.	1,168.

Worksurfaces

Order Code	Specification Information	Application Notes
<p>Example: <b>RCE1L4260SSG 114</b></p> <p><b>RCE1</b> Cascade edge worksurface</p> <p><b>L</b> Blended "L" top</p> <p><b>42</b> Width</p> <p><b>60</b> Depth</p> <p><b>S</b> 24"d, left side</p> <p><b>S</b> 24"d, right side</p> <p><b>G</b> Grommets</p> <p><b>114</b> Top finish</p>	<p>To order please specify pattern number including:</p> <p>1. Return depths (hard coded in pattern number):            SS = 24"d left and right            SD = 24"d left, 30"d right            DS = 30"d left, 24"d right</p> <p>2. Grommets ( hard coded in pattern number):            N= no grommets            G= grommets</p> <p>3. Finishes:  <b>Solid:</b>            114 Folkstone Grey            117 Soft Grey            118 Bright White            119 Pumice</p> <p>Woodgrain:            124 Medium Cherry            125 Natural Maple            126 Natural Cherry            127 Walnut</p>	<p>Center-located edge grommets, located on center of sides marked B and C.</p> <p>All support hardware ordered separately.</p> <p>Worksurface stiffeners are recommended to provide additional support for open spans greater than 48" w.</p> <p>Specify cantilever bracket (ASBC18(L/R) or ASBC24 (L/R)) from page 0-109 as required to support Cascade edge worksurfaces for Reff panel hung applications.</p> <p>Cascade edge worksurfaces are not recommended for free-standing applications.</p> <p>Actual width 1/16" less nominal.            Actual depth 3/8" less nominal for cord drop.</p>
<p>To specify grommets, replace the "N" suffix in pattern number with "G". Add \$40.</p>		<p>Please Note: Cascade Edge worksurfaces are wrapped with a PVC-free, 3D laminate sheet that is heated and pressed around an FSC certified substrate. 3D laminate is more susceptible to denting, impact, tearing and marring than conventional high pressure laminate and should be handled with care. Do not drag worksurfaces across any flooring surface. Treat Cascade Edge worksurfaces like veneer worksurfaces for optimum performance under normal conditions. Cascade Edge worksurfaces come with a 10 year warranty that covers defects in workmanship and materials. This warranty does not cover damage occurring during or after installation.</p>

# Cascade Edge 1 1/4"

## Half round and corner round

description	w	d	pattern no.	Woodgrain	Solid
 Half Round	48"	18"	<b>RCE1H4818</b>	\$520.	\$452.
	50 1/2"	18"	<b>RCE1H4818P</b>	520.	452.
	60"	24"	<b>RCE1H6024</b>	717.	622.
	62 1/2"	24"	<b>RCE1H6024P</b>	717.	622.
 LH Corner Round	24"	24"	<b>RCE1CR24L</b>	276.	240.
 RH Corner Round	24"	24"	<b>RCE1CR24R</b>	276.	240.
 Notched Corner Round	24"	24"	<b>RCE1CR24N</b>	276.	240.

### Order Code

Example:	<b>RCE1H4818P 118</b>
<b>R</b>	Reff
<b>CE1</b>	Cascade edge
<b>H</b>	Half round
<b>48</b>	Width
<b>18</b>	Depth
<b>P</b>	Notch for panel trim
<b>118</b>	Finish

### Specification Information

To order please specify pattern number including finish:  
Available finishes:

#### Solid:

114	Folkstone Grey
117	Soft Grey
118	Bright White
119	Pumice

#### Woodgrain:

124	Medium Cherry
125	Natural Maple
126	Natural Cherry
127	Walnut

### Application Notes

All support hardware ordered separately.

Worksurface stiffeners are recommended to provide additional support for open spans greater than 48"w.

Specify cantilever bracket from page 0-109 as required to support Cascade edge worksurfaces for Reff panel hung applications.

Half round tops with suffix P, notched for panel end trim profile B square only.

Cascade edge worksurfaces are not recommended for free-standing applications.

Actual width 1/16" less nominal.  
Actual depth 3/8" less nominal.

Please Note: Cascade Edge worksurfaces are wrapped with a PVC-free, 3D laminate sheet that is heated and pressed around an FSC certified substrate. 3D laminate is more susceptible to denting, impact, tearing and marring than conventional high pressure laminate and should be handled with care. Do not drag worksurfaces across any flooring surface. Treat Cascade Edge worksurfaces like veneer worksurfaces for optimum performance under normal conditions. Cascade Edge worksurfaces come with a 10 year warranty that covers defects in workmanship and materials. This warranty does not cover damage occurring during or after installation.

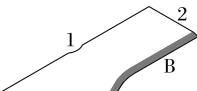

# Cascade Edge 1 1/4" Wave end

description	1	2	3	A	B	pattern no.	Woodgrain	Solid
Wave End, LH 	36"	24"	30"	3"	15"	<b>RCE1W363024N</b>	\$646.	\$562.
	42"	24"	30"	9"	15"	<b>RCE1W423024N</b>	679.	590.
	48"	24"	30"	15"	15"	<b>RCE1W483024N</b>	727.	632.
	72"	24"	30"	30 1/2"	23 1/2"	<b>RCE1W723024N</b>	924.	805.

shown with grommet

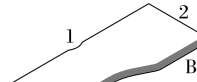
description	1	2	3	A	B	pattern no.	Woodgrain	Solid
Wave End, RH 	36"	30"	24"	15"	3"	<b>RCE1W362430N</b>	646.	562.
	42"	30"	24"	15"	9"	<b>RCE1W422430N</b>	679.	590.
	48"	30"	24"	15"	15"	<b>RCE1W482430N</b>	727.	632.
	72"	30"	24"	23 1/2"	30 1/2"	<b>RCE1W722430N</b>	924.	805.

shown with grommet

Worksurfaces

Order Code	Specification Information
Example: <b>RCE1W483024N 118</b>	<i>To order please specify pattern number including finish:</i>
<b>RCE1</b> Cascade edge worksurface	Available finishes:
<b>W</b> Wave end	<i>Solid:</i>
<b>48</b> Width	114 Folkstone Grey
<b>30</b> Depth, left side	117 Soft Grey
<b>24</b> Depth, right side	118 Bright White
<b>N</b> No grommet	119 Pumice
<b>118</b> Top finish	<i>Woodgrain:</i>
	124 Medium Cherry
	125 Natural Maple
	126 Natural Cherry
	127 Walnut

**Specification Information**

*To order please specify pattern number including finish:*  
Available finishes:

*Solid:*  
114 Folkstone Grey  
117 Soft Grey  
118 Bright White  
119 Pumice

*Woodgrain:*  
124 Medium Cherry  
125 Natural Maple  
126 Natural Cherry  
127 Walnut

**Application Notes**

Center-located edge grommet.

To specify grommet, replace the "N" suffix in pattern number with "G". Add \$20.

All support hardware ordered separately.

Worksurface stiffeners are recommended to provide additional support for open spans greater than 48" w.

Specify cantilever bracket ( ASBC18( L/R ) or ASBC24 (L/R)) from page 0-109 as required to support Cascade edge worksurfaces for Reff panel hung applications.

Cascade edge worksurfaces are not recommended for free-standing applications.

Actual width 1/16" less nominal.  
Actual depth 3/8" less nominal for cord drop.

Please Note: Cascade Edge worksurfaces are wrapped with a PVC-free, 3D laminate sheet that is heated and pressed around an FSC certified substrate. 3D laminate is more susceptible to denting, impact, tearing and marring than conventional high pressure laminate and should be handled with care. Do not drag worksurfaces across any flooring surface. Treat Cascade Edge worksurfaces like veneer worksurfaces for optimum performance under normal conditions. Cascade Edge worksurfaces come with a 10 year warranty that covers defects in workmanship and materials. This warranty does not cover damage occurring during or after installation.

Worksurface 1 1/2"  
 rectilinear  
 20" and 24" deep

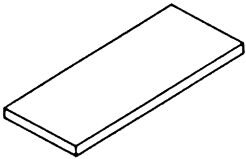
description	d	w	pattern no.	L	M/V1	V2	V3
Straight rectangular work tops 	20"	24"	RSD241-()()()	\$336.	\$366.	\$421.	\$567.
		30"	RSD301-()()()	367.	402.	461.	623.
		36"	RSD361-()()()	389.	424.	487.	659.
		42"	RSD421-()()()	403.	444.	510.	688.
		48"	RSD481-()()()	424.	460.	529.	713.
		54"	RSD541-()()()	441.	478.	553.	748.
		60"	RSD601-()()()	472.	518.	596.	806.
		66"	RSD661-()()()	487.	533.	615.	829.
		72"	RSD721-()()()	515.	562.	644.	870.
		78"	RSD781-()()()	522.	567.	654.	884.
		84"	RSD841-()()()	553.	607.	696.	939.
		90"	RSD961-()()()	579.	631.	723.	979.
		96"	RSD901-()()()	600.	654.	751.	1,014.
	102"	RSD1021-()()()	660.	720.	827.	1,115.	
	108"	RSD1081-()()()	726.	792.	909.	1,226.	
	24"	24"	RSD242-()()()	353.	384.	444.	599.
		30"	RSD302-()()()	399.	434.	502.	676.
		36"	RSD362-()()()	412.	454.	520.	702.
		42"	RSD422-()()()	429.	467.	537.	723.
		48"	RSD482-()()()	455.	502.	576.	776.
		54"	RSD542-()()()	487.	533.	615.	829.
		60"	RSD602-()()()	525.	574.	658.	888.
		66"	RSD662-()()()	539.	601.	681.	919.
72"		RSD722-()()()	566.	617.	712.	962.	
78"		RSD782-()()()	591.	646.	747.	1,007.	
84"		RSD842-()()()	616.	673.	774.	1,045.	
90"		RSD902-()()()	646.	703.	808.	1,089.	
96"		RSD962-()()()	669.	730.	841.	1,135.	
102"		RSD1022-()()()	736.	803.	925.	1,248.	
108"		RSD1082-()()()	809.	883.	1,017.	1,373.	

Order Code	Specification Information	Application Notes
Example: <b>RSD241RL</b>	<i>To order please specify pattern number including:</i>	Applicable finishes are listed on page 5 and 6.
<b>R</b> Reff	1. Grommet option: F=Flush front grommet location N=No grommet R=Recessed front (not recommended for 20"D and 24"D tops)	Products on this page are shipped without hardware which must be ordered separately from the support components section.
<b>S</b> Straight top	2. Grommet finish: Painted, Plated	These worksurfaces are predrilled with metal inserts and use machine screws.
<b>D</b> 1 1/2" thick	3. Top finish: L, V1, V2, V3	Worksurfaces stiffeners recommended to provide additional support for open spans greater than 54"w.
<b>24</b> 24" wide		
<b>1</b> 20" deep		
<b>R</b> Recessed grommet location		
<b>111</b> Jet Black (grommet)		
<b>V316</b> Top finish		

**Knoll accepts no responsibility for special grommet locations which interfere with support or other hardware. All requests for special grommet locations must be approved through custom product development.**

**Actual widths of worksurfaces are 1/16" less than nominal dimension. Actual depth is 1/8" less.**

Worksurface 1 1/2"  
 rectilinear  
 30" and 36" deep

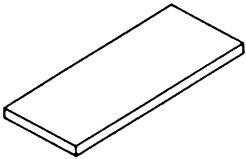
description	d	w	pattern no.	L	M/V1	V2	V3
Straight rectangular work tops 	30"	24"	RSD243-()()()	\$385.	\$418.	\$479.	\$647.
		30"	RSD303-()()()	433.	471.	542.	733.
		36"	RSD363-()()()	464.	509.	583.	786.
		42"	RSD423-()()()	484.	528.	608.	822.
		48"	RSD483-()()()	518.	564.	647.	875.
		54"	RSD543-()()()	559.	610.	699.	944.
		60"	RSD603-()()()	580.	632.	725.	981.
		66"	RSD663-()()()	590.	645.	746.	1,006.
		72"	RSD723-()()()	607.	661.	760.	1,026.
		78"	RSD783-()()()	634.	693.	797.	1,075.
		84"	RSD843-()()()	659.	720.	828.	1,119.
		90"	RSD903-()()()	690.	753.	868.	1,172.
		96"	RSD963-()()()	714.	781.	898.	1,212.
		102"	RSD1023-()()()	786.	859.	988.	1,334.
	108"	RSD1083-()()()	864.	945.	1,087.	1,467.	
	36"	60"	RSD604-()()()	668.	729.	836.	1,119.
		66"	RSD664-()()()	690.	754.	869.	1,173.
		72"	RSD724-()()()	713.	780.	897.	1,211.

Worksurfaces

Order Code	Specification Information	Application Notes
Example: <b>RSD243RL</b>	<i>To order please specify pattern number including:</i>	Applicable finishes are listed on page 5 and 6.
<b>R</b> Reff	1. Grommet options: N = No grommets F = Flush front grommet location R = Recessed front (not recommended for 20"D and 24"D tops) A = Alternate location (for 36"D tops only)	Products on this page are shipped without hardware which must be ordered separately from the support components section.
<b>S</b> Straight top	2. Grommet finish: Painted, Plated	These worksurfaces are predrilled with metal inserts and use machine screws.
<b>D</b> 1 1/2" thick	3. Finish: L, V1, V2, V3	Worksurfaces stiffeners recommended to provide additional support for open spans greater than 54"w.
<b>36</b> 36" wide		<b>Knoll accepts no responsibility for special grommet locations which interfere with support or other hardware. All requests for special grommet locations must be approved through custom product development.</b>
<b>3</b> 30" deep		<b>Actual widths of worksurfaces are 1/16" less than nominal dimension. Actual depth is 1/8" less.</b>
<b>R</b> Recessed grommet location		
<b>111</b> Jet Black (grommet)		
<b>V316</b> Top finish		

# Worksurface 1 1/2" Bridge rectilinear

Reff Profiles

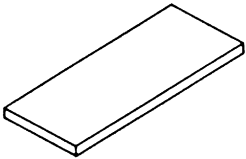
description	d	w	pattern no.	L	V1	V2	V3
Worksurface, bridge rectilinear 	20"	36"	<b>RBD361V</b> ( ) ( ) ( )	\$389.	\$424.	\$487.	\$659.
		36"	<b>RBD361H</b> ( ) ( ) ( )	389.	424.	487.	659.
		42"	<b>RBD421H</b> ( ) ( ) ( )	403.	444.	510.	688.
		42"	<b>RBD421V</b> ( ) ( ) ( )	403.	444.	510.	688.
		48"	<b>RBD481H</b> ( ) ( ) ( )	424.	460.	529.	713.
		48"	<b>RBD481V</b> ( ) ( ) ( )	424.	460.	529.	713.
		54"	<b>RBD541V</b> ( ) ( ) ( )	441.	478.	553.	748.
		54"	<b>RBD541H</b> ( ) ( ) ( )	441.	478.	553.	748.
	24"	36"	<b>RBD362V</b> ( ) ( ) ( )	412.	454.	520.	702.
		36"	<b>RBD362H</b> ( ) ( ) ( )	412.	454.	520.	702.
		42"	<b>RBD422H</b> ( ) ( ) ( )	429.	467.	537.	723.
		42"	<b>RBD422V</b> ( ) ( ) ( )	429.	467.	537.	723.
		48"	<b>RBD482H</b> ( ) ( ) ( )	455.	502.	576.	776.
		48"	<b>RBD482V</b> ( ) ( ) ( )	455.	502.	576.	776.
54"		<b>RBD542H</b> ( ) ( ) ( )	487.	533.	615.	829.	
54"		<b>RBD542V</b> ( ) ( ) ( )	487.	533.	615.	829.	

## Order Code

Example: <b>RBD361H</b>	
<b>R</b>	Reff
<b>B</b>	Bridge
<b>D</b>	1 1/2"
<b>36</b>	36" wide
<b>H/V</b>	
<b>F</b>	Grommet type
<b>115</b>	Grommet finish
<b>114</b>	Laminate

## Specification Information

- To order please specify pattern number including:*
- Options for grain direction  
H=Horizontal grain direction  
V=Vertical grain direction
  - Grommet type:  
N=No grommet  
F=Flush front grommet locaton
  - Grommet finish:  
Painted, Plated
  - Finish  
L, V1, V2, V3

## Application Notes

- Modesty sold separately
- J-Bracket sold separately.
- Stiffener sold separately
- Above dimensions are all nominal.
- Assembly required.
- Worksurface stiffeners recommended to provide additional support for open spans greater than 54" w.
- Hardware not included.

# Worksurface Credenza

## 1" No grommet

Reff Profiles

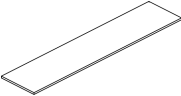
description	d	w	pattern no.	L	M/V1	V2	V3
Credenza tops 	20"	60"	<b>RCE601()</b>	\$458.	\$458.	\$527.	\$713.
		66"	<b>RCE661()</b>	472.	472.	544.	734.
		72"	<b>RCE721()</b>	497.	497.	570.	770.
		78"	<b>RCE781()</b>	502.	502.	579.	782.
		84"	<b>RCE841()</b>	537.	537.	616.	831.
		90"	<b>RCE901()</b>	558.	558.	640.	866.
		96"	<b>RCE961()</b>	579.	579.	665.	897.
		102"	<b>RCE1021()</b>	637.	637.	732.	987.
	108"	<b>RCE1081()</b>	701.	701.	805.	1,085.	
	24"	60"	<b>RCE602()</b>	508.	508.	582.	786.
		66"	<b>RCE662()</b>	523.	523.	603.	813.
		72"	<b>RCE722()</b>	546.	546.	630.	851.
		78"	<b>RCE782()</b>	572.	572.	661.	891.
		84"	<b>RCE842()</b>	596.	596.	685.	925.
		90"	<b>RCE902()</b>	622.	622.	715.	964.
		96"	<b>RCE962()</b>	646.	646.	744.	1,004.
102"		<b>RCE1022()</b>	711.	711.	818.	1,104.	
108"	<b>RCE1082()</b>	782.	782.	900.	1,215.		

Worksurfaces

Order Code	Specification Information	Application Notes
Example: <b>RCE601</b>	<i>To order please specify pattern number including:</i> 1. Finish L,V1,V2,V3	No grommet options  Credenza tops are drilled to accept pedestals and end panels.  1" Credenza tops are recommended to work with the Task Panel application.  Credenza tops are intended to be supported by full lower storage.
<b>R</b> Reff		
<b>C</b> Credenza Top		
<b>E</b> 1"		
<b>60</b> width		
<b>1</b> 20"		
<b>V316</b> Finish		

# Worksurface Credenza

## 1" with edge grommet

Reff Profiles

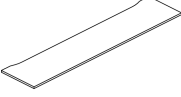
description	d	w	pattern no.	L	M/V1	V2	V3
Credenza tops with grommet 	20"	60"	<b>RCEEG601()</b>	\$641.	\$641.	\$738.	\$998.
		66"	<b>RCEEG661()</b>	661.	661.	762.	1,028.
		72"	<b>RCEEG721()</b>	696.	696.	798.	1,078.
		78"	<b>RCEEG781()</b>	703.	703.	811.	1,095.
		84"	<b>RCEEG841()</b>	752.	752.	862.	1,163.
		90"	<b>RCEEG901()</b>	781.	781.	896.	1,212.
		96"	<b>RCEEG961()</b>	811.	811.	931.	1,256.
		102"	<b>RCEEG1021()</b>	892.	892.	1,024.	1,381.
		108"	<b>RCEEG1081()</b>	981.	981.	1,127.	1,520.
	24"	60"	<b>RCEEG602()</b>	711.	711.	815.	1,100.
		66"	<b>RCEEG662()</b>	732.	732.	844.	1,138.
		72"	<b>RCEEG722()</b>	764.	764.	882.	1,191.
		78"	<b>RCEEG782()</b>	801.	801.	925.	1,247.
		84"	<b>RCEEG842()</b>	834.	834.	959.	1,295.
		90"	<b>RCEEG902()</b>	871.	871.	1,001.	1,350.
96"		<b>RCEEG962()</b>	904.	904.	1,042.	1,406.	
102"		<b>RCEEG1022()</b>	995.	995.	1,146.	1,546.	
108"		<b>RCEEG1082()</b>	1,094.	1,094.	1,260.	1,701.	

### Order Code

Example: <b>RCEEG601</b>	
<b>R</b>	Reff
<b>C</b>	Credenza Top
<b>E</b>	1"
<b>EG</b>	Edge Grommet
<b>60</b>	Width
<b>1</b>	20"
<b>V316</b>	Finish

### Specification Information

To order please specify pattern number including:

1. Top finish  
L,V1,V2,V3

### Application Notes

These tops will always come with a cut out (notch) at the back of top.

No grommet option.

Credenza tops are drilled to accept pedestals.

1" Credenza tops are recommended to work with the Task Panel application.

Credenza tops are intended to be supported by full lower storage.

# Worksurface Credenza

## 1 1/2" with edge grommet

Reff Profiles

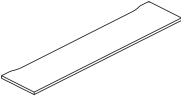
description	d	w	pattern no.	L	M/V1	V2	V3
Credenza tops 	20"	60"	<b>RCD601()</b>	\$705.	\$705.	\$812.	\$1,098.
		66"	<b>RCD661()</b>	727.	727.	838.	1,130.
		72"	<b>RCD721()</b>	765.	562.	878.	1,186.
		78"	<b>RCD781()</b>	773.	773.	892.	1,204.
		84"	<b>RCD841()</b>	827.	827.	949.	1,280.
		90"	<b>RCD901()</b>	859.	859.	986.	1,334.
		96"	<b>RCD961()</b>	892.	892.	1,024.	1,381.
		102"	<b>RCD1021()</b>	981.	981.	1,127.	1,520.
		108"	<b>RCD1081()</b>	1,079.	1,079.	1,239.	1,671.
	24"	60"	<b>RCD602()</b>	782.	782.	896.	1,210.
		66"	<b>RCD662()</b>	805.	805.	929.	1,252.
		72"	<b>RCD722()</b>	841.	841.	970.	1,311.
		78"	<b>RCD782()</b>	881.	881.	1,018.	1,372.
		84"	<b>RCD842()</b>	918.	918.	1,055.	1,425.
		90"	<b>RCD902()</b>	958.	958.	1,101.	1,485.
		96"	<b>RCD962()</b>	995.	995.	1,146.	1,546.
		102"	<b>RCD1022()</b>	1,094.	1,094.	1,260.	1,701.
108"		<b>RCD1082()</b>	1,204.	1,204.	1,386.	1,871.	

Worksurfaces

### Order Code

Example: <b>RCEEG601</b>
<b>R</b> Reff
<b>C</b> Credenza
<b>D</b> 1 1/2" top
<b>60</b> Width
<b>1</b> 20"
<b>V316</b> Finish

### Specification Information

To order please specify pattern number including:

1. Finish  
L, V1, V2, V3

### Application Notes

These tops will always come with a cut out (notch) at the back of top.

No grommet option.

Credenza tops are drilled to accept pedestals.

1" Credenza tops are recommended to work with the Task Panel application.

Credenza tops are intended to be supported by full lower storage.

# Peninsula 1 1/2"

## Planning Guidelines and Specifications

### Peninsulas

Peninsulas for Reff Profiles are a central element in private office planning. Peninsulas are available in two styles; flush mounted and over-sailing. The flush mounted style is intended to connect tops which use full height pedestals for support, creating a flush transition

between the peninsula and the adjoining top. The over-sailing style of peninsula is designed to overlap low storage made up of 3/4 height cabinets with 1" credenza tops or Progressive low credenzas by using a stand-off to support the peninsula top and create a space between the top and the low storage element.

See diagrams below and page following for descriptions. Peninsulas are offered as complete assemblies including worksurface, leg(s), credenza support, and grommet options.

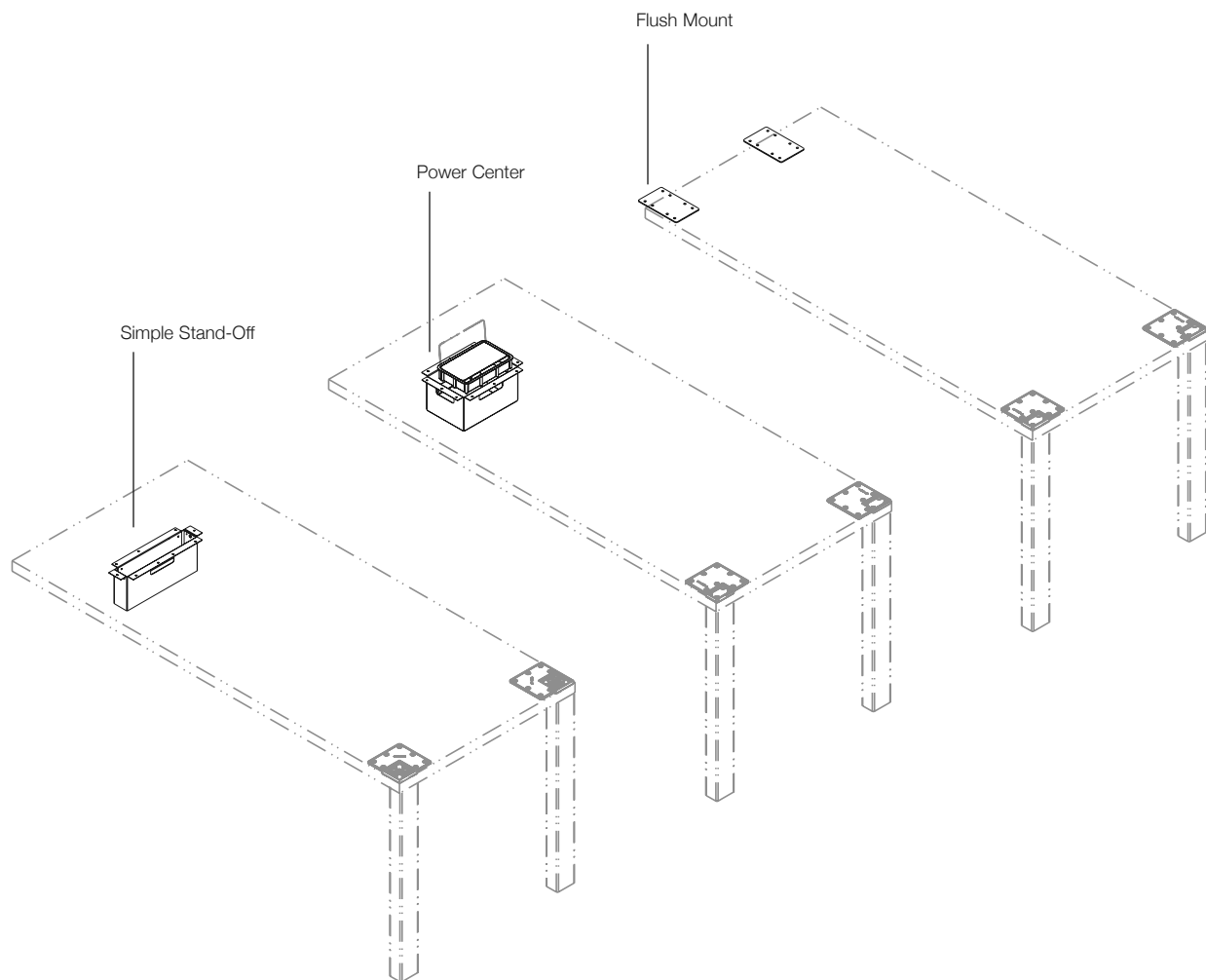



# Peninsula 1 1/2"

## Planning Guidelines and Specifications

### Specification Options

Peninsulas are available with a variety of worksurface shapes including rectilinear, asymmetrical and symmetrical bullet, P, 9 and D shapes.

Peninsula tops are available in any Reff Profiles core laminate or veneer finish; see Reff Profiles finish options pages for further information.

Laminate tops are offered with color-matched edges or wood veneer edges as a mixed finish option. Edge material for veneer tops is wood.

Flush mounted peninsulas, previous page below right, come with Flush Mounting kit including two flush plates and connection hardware.

Over-sailing peninsulas are offered with two stand-off options; Power Center, previous page middle, and Simple stand-off, previous page left.

The Power Center kit is supplied with power center grommet, stand-off, round cable grommet and connection hardware. When specified with a Power Center, the peninsula

top is pre-drilled to accept the Power Center grommet. The Power Center stand-off is field installed to the peninsula top and lower storage. Refer to PN #6TP00081 for Power Center Stand-Off installation instructions.

In the recommended mounting location, the peninsula top will be 2 1/2" from the wall or the back edge of the 1" credenza top (over 3/4 height pedestals). Refer to elevation diagrams below for details.

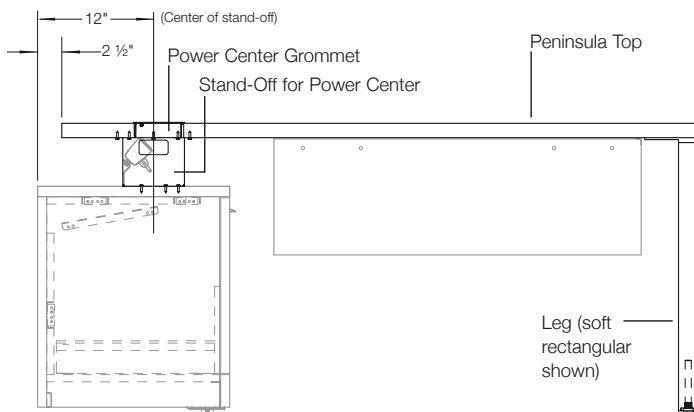

**Over-Sailing Style**  
Peninsula with Power Center

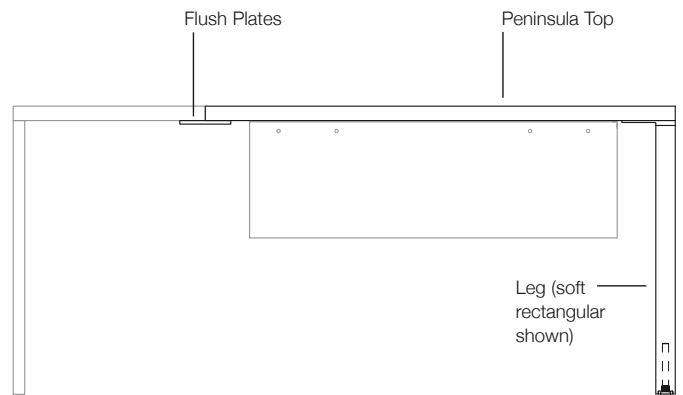

**Flush Mounted Style**  
Peninsula with Flush Mount

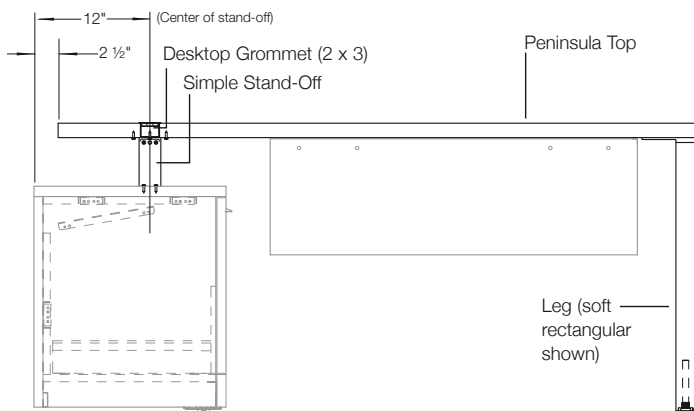

**Over-Sailing Style**  
Peninsula with Simple Stand-Off

# Peninsula 1 1/2"

## Planning Guidelines and Specifications

The Simple Stand-Off kit is supplied with a simple stand-off, stand-off mount, round cable grommet and connection hardware. When specified, the peninsula top is pre-drilled to accept the 2 x 3 grommet. The Simple Stand-Off is field installed to the peninsula top and lower storage. Refer to PN #6TP00081 for Power Center Stand-Off installation instructions.

Power center and 2 x 3 grommets are offered in three plated finishes; Black Nickel (PN), Polished Chrome (PD) and Satin Nickel (PU) and all core paint finishes.

Stand-Off's are offered in all Reff Profiles core paint finishes.

### Rectilinear Tops Right Hand Shown

Simple Stand-Off	Power Center	Flush Mount

# Peninsula 1 1/2"

## Planning Guidelines and Specifications

Leg options for Peninsulas include L-leg, reverse L-leg, soft rectangular leg, open frame leg and cylindrical column leg. L, reverse L, soft rectangular and open frame legs are offered with anodized finishes: Black (AN), Polished (AP) and Satin (AU).

Cylindrical column leg is offered with plated finishes: Black Nickel (PN), Polished Chrome (PD) and Satin Nickel (PU).

All legs are available in all Reff Profiles core paint finishes.

Rectilinear peninsula tops are offered with L, reverse L, soft rectangular, and open frame leg options. All other peninsula tops are offered with cylindrical column leg.

Refer to figures on previous page and following for grommet locations and order codes.

### Asymmetric Bullet Tops Right Hand Shown

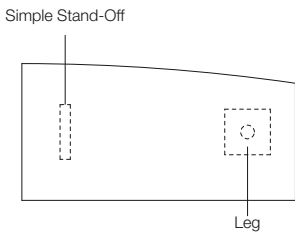
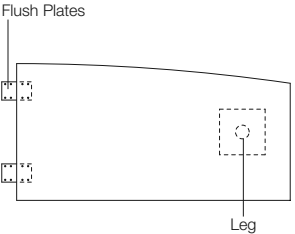
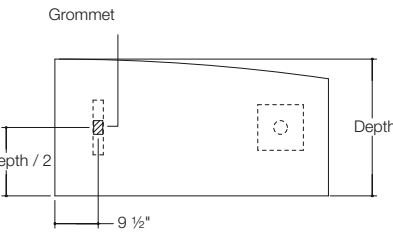
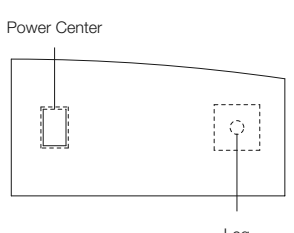
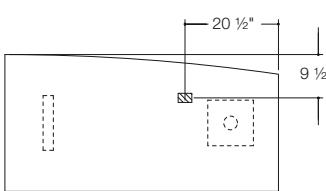
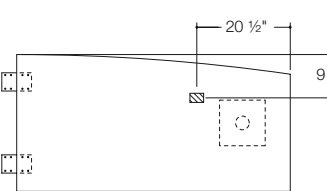
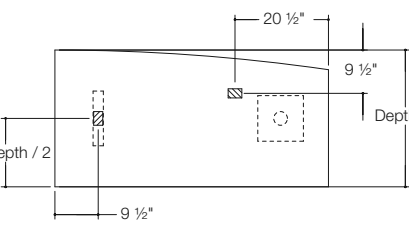
Simple Stand-Off	Power Center	Flush Mount
 <p>Simple Stand-Off</p> <p>N</p> <p>Leg</p>		 <p>Flush Plates</p> <p>N</p> <p>Leg</p>
 <p>Grommet</p> <p>Depth / 2</p> <p>9 1/2"</p> <p>S</p> <p>Depth</p>	 <p>Power Center</p> <p>P</p> <p>Leg</p>	
 <p>20 1/2"</p> <p>9 1/2"</p> <p>E</p>		 <p>20 1/2"</p> <p>9 1/2"</p> <p>E</p>
 <p>Depth / 2</p> <p>9 1/2"</p> <p>SE</p> <p>Depth</p>		

# Peninsula 1 1/2"

## Planning Guidelines and Specifications

### Construction

Reff Profiles peninsula tops are nominal 1 1/2" thick, consisting of 1 7/16" thick substrate with a laminate or veneer surface finish.

Laminate tops have a laminate top surface with an FSC-certified particle board core and a paper backer sheet for balanced construction. Edges can match the top or are available in a selection

of veneers. Matching edges are in 2.0mm ABS with 2.0mm radius top and bottom edges. End edges overlap the front and back edges with the outside corners minimally radiused.

Edges on veneer tops are 2.4mm thick wood with 2.4mm radius top and bottom edges. Ends overlap front and back edges

with 2.4mm radius on outside corners.

All tops are supplied with pilot holes for hardware inserts for attachment of specified leg options.

Legs are shipped separately, fully assembled with connection hardware included.

### Symmetric Bullet Tops Right Hand Shown

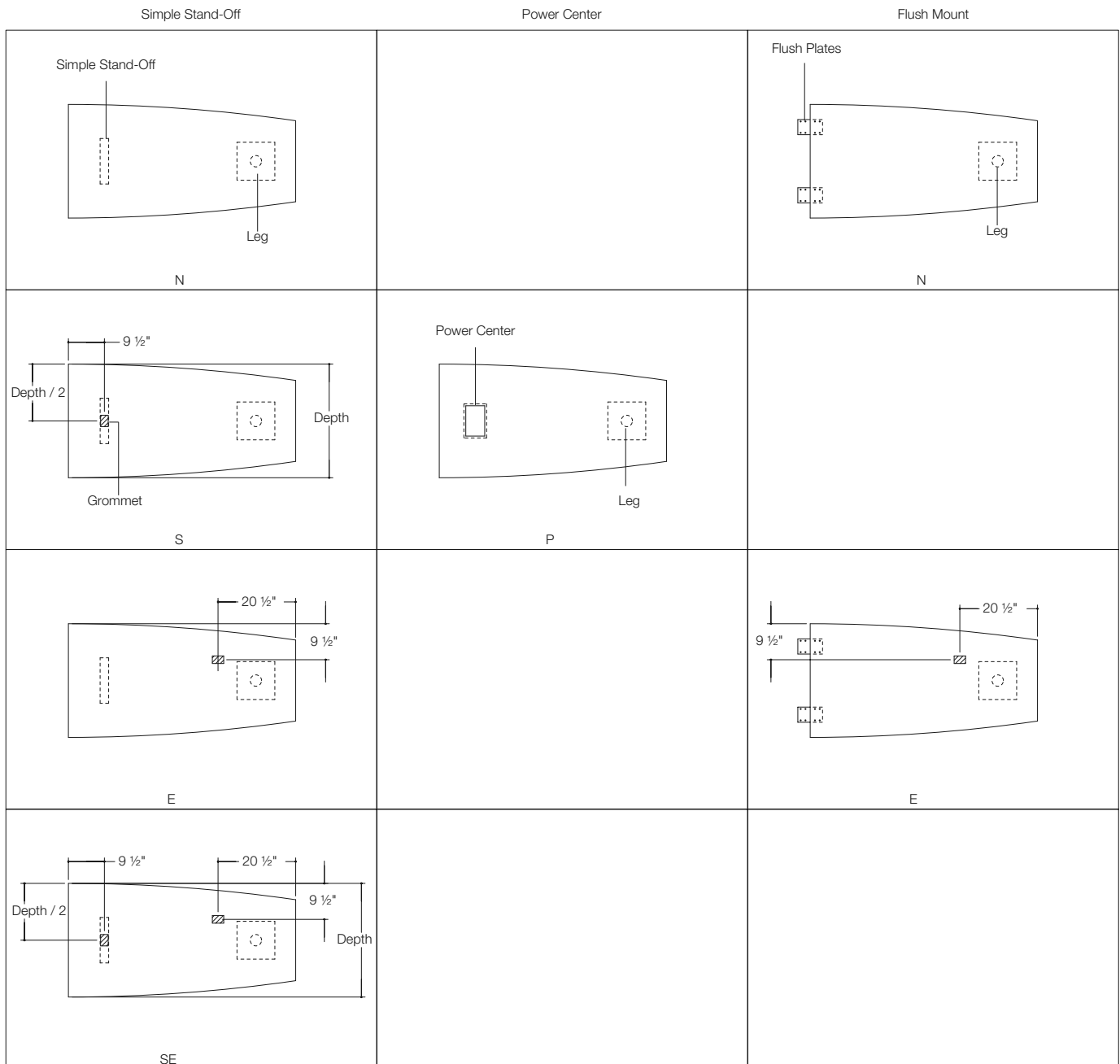

# Peninsula 1 1/2"

## Planning Guidelines and Specifications

### Planning Notes

1. Partial height modesty is available, sold separately and field installed.
2. J-wire manager is available, sold separately and field installed.
3. Peninsula tops require additional stiffening for spans greater than 54".
4. Peninsula top is right handed when the leg is on the right hand side (from the users perspective) and vice versa.
5. Power center electrical components are not included with the Peninsula and are ordered separately.

### P and 9 Tops

Flush Mount Options:

P-Shaped







9-Shaped

<p>No Grommet</p>		
<p>Single Grommet</p>		
<p>Double Grommet</p>		

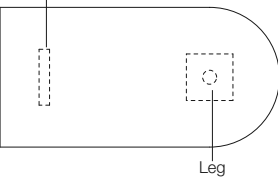
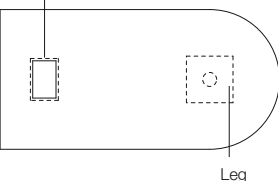
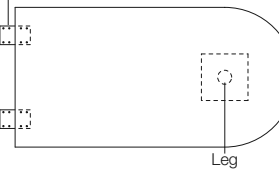
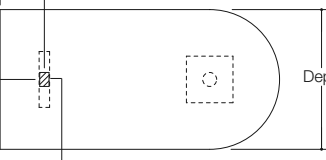
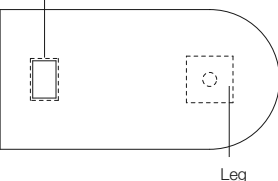
# Peninsula 1 1/2"

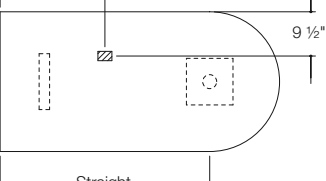
## Planning Guidelines and Specifications

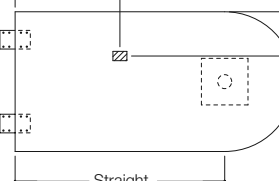
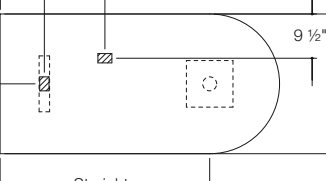
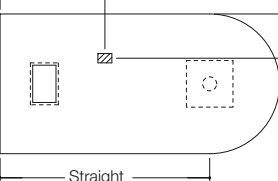
### D Tops Right Hand Shown

Simple Stand-Off	Power Center	Flush Mount
<p>Simple Stand-Off</p>  <p>N</p>	<p>Power Center</p>  <p>N</p>	<p>Flush Plates</p>  <p>N</p>
<p>9 1/2"</p> <p>Depth / 2</p>  <p>Grommet</p> <p>S</p>	<p>Power Center</p>  <p>Leg</p> <p>P</p>	<p>Flush Plates</p>  <p>Leg</p> <p>M</p>
<p>Straight / 2</p>  <p>M</p>	<p>Power Center</p>  <p>Leg</p> <p>P</p>	<p>Flush Plates</p>  <p>Leg</p> <p>M</p>
<p>9 1/2"</p> <p>Depth / 2</p>  <p>Straight</p> <p>SM</p>	<p>Power Center</p>  <p>Leg</p> <p>PM</p>	<p>Flush Plates</p>  <p>Leg</p> <p>M</p>

Peninsula 1 1/2"  
 Worksurface with L-leg  
 Stand-Off with Power Center, Rectilinear top

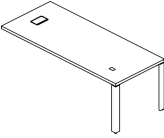
description	d	w	th	pattern no.	L	M/V1	V2	V3
 Peninsula Rectilinear Top  Left hand shown	20"	60"	1 1/2"	RPTDLPC(L/R)6020( ) ( ) ( ) ( )	\$1,421.	\$1,463.	\$1,541.	\$1,751.
		66"	1 1/2"	RPTDLPC(L/R)6620( ) ( ) ( ) ( )	1,432.	1,478.	1,560.	1,774.
		72"	1 1/2"	RPTDLPC(L/R)7220( ) ( ) ( ) ( )	1,460.	1,507.	1,589.	1,815.
		78"	1 1/2"	RPTDLPC(L/R)7820( ) ( ) ( ) ( )	1,467.	1,512.	1,599.	1,829.
		84"	1 1/2"	RPTDLPC(L/R)8420( ) ( ) ( ) ( )	1,498.	1,552.	1,641.	1,884.
	24"	60"	1 1/2"	RPTDLPC(L/R)6024( ) ( ) ( ) ( )	1,470.	1,519.	1,603.	1,833.
		66"	1 1/2"	RPTDLPC(L/R)6624( ) ( ) ( ) ( )	1,484.	1,536.	1,626.	1,864.
		72"	1 1/2"	RPTDLPC(L/R)7224( ) ( ) ( ) ( )	1,511.	1,562.	1,657.	1,907.
		78"	1 1/2"	RPTDLPC(L/R)7824( ) ( ) ( ) ( )	1,536.	1,591.	1,692.	1,952.
		84"	1 1/2"	RPTDLPC(L/R)8424( ) ( ) ( ) ( )	1,561.	1,618.	1,719.	1,990.
	30"	60"	1 1/2"	RPTDLPC(L/R)6030( ) ( ) ( ) ( )	1,525.	1,577.	1,670.	1,926.
		66"	1 1/2"	RPTDLPC(L/R)6630( ) ( ) ( ) ( )	1,535.	1,590.	1,691.	1,951.
		72"	1 1/2"	RPTDLPC(L/R)7230( ) ( ) ( ) ( )	1,552.	1,606.	1,705.	1,971.
		78"	1 1/2"	RPTDLPC(L/R)7830( ) ( ) ( ) ( )	1,579.	1,638.	1,742.	2,020.
		84"	1 1/2"	RPTDLPC(L/R)8430( ) ( ) ( ) ( )	1,604.	1,665.	1,773.	2,064.
	36"	60"	1 1/2"	RPTDLPC(L/R)6036( ) ( ) ( ) ( )	1,613.	1,674.	1,781.	2,064.
		66"	1 1/2"	RPTDLPC(L/R)6636( ) ( ) ( ) ( )	1,635.	1,699.	1,814.	2,118.
		72"	1 1/2"	RPTDLPC(L/R)7236( ) ( ) ( ) ( )	1,658.	1,725.	1,842.	2,156.
		78"	1 1/2"	RPTDLPC(L/R)7836( ) ( ) ( ) ( )	1,681.	1,747.	1,870.	2,196.
		84"	1 1/2"	RPTDLPC(L/R)8436( ) ( ) ( ) ( )	1,703.	1,770.	1,899.	2,235.

Worksurfaces

Order Code	Specification Information	Application Notes
Example: <b>RPTDLPC(L/R)6030( ) ( ) ( ) ( )</b>	<i>To order please specify pattern number including:</i>	Modesty sold separately and can be field installed.
<b>R</b> Reff	1. Left or Right hand	Wire chase sold separately.
<b>PT</b> Peninsula	2. Grommet option P=Power Center, PE= Power center grommet	Worksurface stiffeners, recommended to provide additional support for open spans greater than 48"w.
<b>D</b> 1 1/2"	3. Grommet option Painted or plated	Refer to grommet page for location option.
<b>L</b> L-leg	4. Worksurface finish L, V1, V2, V3	From users perspective, if the leg is on the right side, the peninsula is classified a "Right Hand" peninsula.
<b>PC</b> Power Center	5. Leg finish Painted or Anodized	
<b>L</b> Left hand/ Right hand	6. Stand-off finish Painted	
<b>60</b> Width		
<b>30</b> Depth		
<b>P</b> Grommet option		
<b>115</b> Grommet Finish		
<b>114</b> Worksurface Finish		
<b>115</b> Leg Finish		
<b>115</b> Stand-Off Finish		

Peninsula 1 1/2"  
 Worksurface with L-leg  
 Simple Stand-Off, Rectilinear top

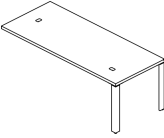
description	d	w	th	pattern no.	L	M/V1	V2	V3
 Peninsula Rectilinear Top  <i>Left hand shown</i>	20"	60"	1 1/2"	RPTDLST(L/R)6020( ) ( ) ( ) ( )	\$1,351.	\$1,393.	\$1,471.	\$1,681.
		66"	1 1/2"	RPTDLST(L/R)6620( ) ( ) ( ) ( )	1,362.	1,408.	1,490.	1,704.
		72"	1 1/2"	RPTDLST(L/R)7220( ) ( ) ( ) ( )	1,390.	1,437.	1,519.	1,745.
		78"	1 1/2"	RPTDLST(L/R)7820( ) ( ) ( ) ( )	1,397.	1,442.	1,529.	1,759.
		84"	1 1/2"	RPTDLST(L/R)8420( ) ( ) ( ) ( )	1,428.	1,482.	1,571.	1,814.
	24"	60"	1 1/2"	RPTDLST(L/R)6024( ) ( ) ( ) ( )	1,400.	1,449.	1,533.	1,763.
		66"	1 1/2"	RPTDLST(L/R)6624( ) ( ) ( ) ( )	1,414.	1,466.	1,556.	1,794.
		72"	1 1/2"	RPTDLST(L/R)7224( ) ( ) ( ) ( )	1,441.	1,492.	1,587.	1,837.
		78"	1 1/2"	RPTDLST(L/R)7824( ) ( ) ( ) ( )	1,466.	1,521.	1,622.	1,882.
		84"	1 1/2"	RPTDLST(L/R)8424( ) ( ) ( ) ( )	1,491.	1,548.	1,649.	1,920.
	30"	60"	1 1/2"	RPTDLST(L/R)6030( ) ( ) ( ) ( )	1,455.	1,507.	1,600.	1,856.
		66"	1 1/2"	RPTDLST(L/R)6630( ) ( ) ( ) ( )	1,465.	1,520.	1,621.	1,881.
		72"	1 1/2"	RPTDLST(L/R)7230( ) ( ) ( ) ( )	1,482.	1,536.	1,635.	1,901.
		78"	1 1/2"	RPTDLST(L/R)7830( ) ( ) ( ) ( )	1,509.	1,568.	1,672.	1,950.
		84"	1 1/2"	RPTDLST(L/R)8430( ) ( ) ( ) ( )	1,534.	1,595.	1,703.	1,994.
	36"	60"	1 1/2"	RPTDLST(L/R)6036( ) ( ) ( ) ( )	1,543.	1,604.	1,711.	1,994.
		66"	1 1/2"	RPTDLST(L/R)6636( ) ( ) ( ) ( )	1,565.	1,629.	1,744.	2,048.
		72"	1 1/2"	RPTDLST(L/R)7236( ) ( ) ( ) ( )	1,588.	1,655.	1,772.	2,086.
		78"	1 1/2"	RPTDLST(L/R)7836( ) ( ) ( ) ( )	1,611.	1,677.	1,800.	2,126.
		84"	1 1/2"	RPTDLST(L/R)8436( ) ( ) ( ) ( )	1,633.	1,700.	1,829.	2,165.

Order Code	Specification Information	Application Notes
Example: <b>RPTDLST(L/R)6030( ) ( ) ( ) ( )</b>	<i>To order please specify pattern number including:</i>	Modesty sold separately and can be field installed.
<b>R</b> Reff	1. Left or Right hand	Wire chase sold separately.
<b>PT</b> Peninsula	2. Grommet option S=Stand-off, N=No grommet, E=End grommet, SE=Stand-off grommet with end grommet.	Worksurface stiffeners, recommended to provide additional support for open spans greater than 48"w.
<b>D</b> 1 1/2"	3. Grommet option Painted or plated	Refer to grommet page for location option.
<b>L</b> L-Leg	4. Worksurface finish L, V1, V2, V3	From users perspective, if the leg is on the right side, the peninsula is classified a "Right Hand" peninsula.
<b>ST</b> Stand-Off	5. Leg finish Painted or Anodized	
<b>L</b> Left hand/ Right hand	6. Stand-off finish Painted	
<b>60</b> Width		
<b>30</b> Depth		
<b>E</b> Grommet Type		
<b>115</b> Grommet Finish		
<b>114</b> Worksurface Finish		
<b>115</b> Leg Finish		
<b>115</b> Stand-Off Finish		

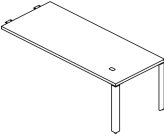

Peninsula 1 1/2"  
 Worksurface with L-leg  
 Flush Mount Attachment, Rectilinear top

description	d	w	th	pattern no.	L	M/V1	V2	V3
 Peninsula Rectilinear Top	20"	48"	1 1/2"	RPTDLFM(L/R)4820( ) ( ) ( ) ( )	\$1,139.	\$1,175.	\$1,244.	\$1,428.
		54"	1 1/2"	RPTDLFM(L/R)5420( ) ( ) ( ) ( )	1,156.	1,193.	1,268.	1,463.
		60"	1 1/2"	RPTDLFM(L/R)6020( ) ( ) ( ) ( )	1,191.	1,233.	1,311.	1,521.
		66"	1 1/2"	RPTDLFM(L/R)6620( ) ( ) ( ) ( )	1,202.	1,248.	1,330.	1,544.
		72"	1 1/2"	RPTDLFM(L/R)7220( ) ( ) ( ) ( )	1,230.	1,277.	1,359.	1,585.
		78"	1 1/2"	RPTDLFM(L/R)7820( ) ( ) ( ) ( )	1,237.	1,282.	1,369.	1,599.
		84"	1 1/2"	RPTDLFM(L/R)8420( ) ( ) ( ) ( )	1,268.	1,322.	1,411.	1,654.
		24"	48"	1 1/2"	RPTDLFM(L/R)4824( ) ( ) ( ) ( )	1,170.	1,217.	1,291.
54"	1 1/2"	RPTDLFM(L/R)5424( ) ( ) ( ) ( )	1,202.	1,248.	1,330.	1,544.		
60"	1 1/2"	RPTDLFM(L/R)6024( ) ( ) ( ) ( )	1,240.	1,289.	1,373.	1,603.		
66"	1 1/2"	RPTDLFM(L/R)6624( ) ( ) ( ) ( )	1,254.	1,306.	1,396.	1,634.		
72"	1 1/2"	RPTDLFM(L/R)7224( ) ( ) ( ) ( )	1,281.	1,332.	1,427.	1,677.		
78"	1 1/2"	RPTDLFM(L/R)7824( ) ( ) ( ) ( )	1,306.	1,361.	1,462.	1,722.		
84"	1 1/2"	RPTDLFM(L/R)8424( ) ( ) ( ) ( )	1,331.	1,388.	1,489.	1,760.		
36"	48"	1 1/2"	RPTDLFM(L/R)4836( ) ( ) ( ) ( )	1,338.	1,399.	1,495.	1,755.	
54"	1 1/2"	RPTDLFM(L/R)5436( ) ( ) ( ) ( )	1,360.	1,421.	1,523.	1,794.		
60"	1 1/2"	RPTDLFM(L/R)6036( ) ( ) ( ) ( )	1,383.	1,444.	1,551.	1,834.		
66"	1 1/2"	RPTDLFM(L/R)6636( ) ( ) ( ) ( )	1,405.	1,469.	1,584.	1,888.		
72"	1 1/2"	RPTDLFM(L/R)7236( ) ( ) ( ) ( )	1,428.	1,495.	1,612.	1,926.		
78"	1 1/2"	RPTDLFM(L/R)7836( ) ( ) ( ) ( )	1,451.	1,517.	1,640.	1,966.		
84"	1 1/2"	RPTDLFM(L/R)8436( ) ( ) ( ) ( )	1,473.	1,540.	1,669.	2,005.		
30"	48"	1 1/2"	RPTDLFM(L/R)4830( ) ( ) ( ) ( )	1,249.	1,301.	1,384.	1,617.	
54"	1 1/2"	RPTDLFM(L/R)5430( ) ( ) ( ) ( )	1,272.	1,324.	1,412.	1,656.		
60"	1 1/2"	RPTDLFM(L/R)6030( ) ( ) ( ) ( )	1,295.	1,347.	1,440.	1,696.		
66"	1 1/2"	RPTDLFM(L/R)6630( ) ( ) ( ) ( )	1,305.	1,360.	1,461.	1,721.		
72"	1 1/2"	RPTDLFM(L/R)7230( ) ( ) ( ) ( )	1,322.	1,376.	1,475.	1,741.		
78"	1 1/2"	RPTDLFM(L/R)7830( ) ( ) ( ) ( )	1,349.	1,408.	1,512.	1,790.		
84"	1 1/2"	RPTDLFM(L/R)8430( ) ( ) ( ) ( )	1,374.	1,435.	1,543.	1,834.		

Left hand shown

Worksurfaces

Order Code	Specification Information	Application Notes
Example: <b>RPTDLFM(L/R)4830( ) ( ) ( )</b>	To order please specify pattern number including:	Modesty sold separately and can be field installed.
<b>R</b> Reff	1. Left or Right hand	Wire chase sold separately.
<b>PT</b> Peninsula	2. Grommet option E=End, N=No grommet, M=Middle grommet	Worksurface stiffeners, recommended to provide additional support for open spans greater than 48" w.
<b>D</b> 1 1/2"	3. Grommet finish Painted or plated	Refer to grommet page for location option.
<b>IL</b> L-leg	4. Worksurface finish L, V1, V2, V3	From users perspective, if the leg is on the right side, the peninsula is classified a "Right Hand" peninsula.
<b>FM</b> Flush Mount Attachment Plate	5. Leg finish Painted or Anodized	
<b>L</b> Left hand/ Right hand		
<b>48</b> Width		
<b>30</b> Depth		
<b>M</b> Grommet Option		
<b>115</b> Grommet Finish		
<b>114</b> Worksurface Finish		
<b>115</b> Leg Finish		

Peninsula 1 1/2"  
 Worksurface with Reverse L-leg  
 Stand Off with Power Center, Rectilinear top

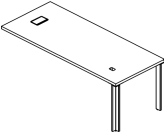
description	d	w	th	pattern no.	L	M/V1	V2	V3
 <p>Left hand shown</p>	20"	60"	1 1/2"	RPTDRPC(L/R)6020( ) ( ) ( ) ( )	\$1,421.	\$1,463.	\$1,541.	\$1,751.
		66"	1 1/2"	RPTDRPC(L/R)6620( ) ( ) ( ) ( )	1,432.	1,478.	1,560.	1,774.
		72"	1 1/2"	RPTDRPC(L/R)7220( ) ( ) ( ) ( )	1,460.	1,507.	1,589.	1,815.
		78"	1 1/2"	RPTDRPC(L/R)7820( ) ( ) ( ) ( )	1,467.	1,512.	1,599.	1,829.
		84"	1 1/2"	RPTDRPC(L/R)8420( ) ( ) ( ) ( )	1,498.	1,552.	1,641.	1,884.
	24"	60"	1 1/2"	RPTDRPC(L/R)6024( ) ( ) ( ) ( )	1,470.	1,519.	1,603.	1,833.
		66"	1 1/2"	RPTDRPC(L/R)6624( ) ( ) ( ) ( )	1,484.	1,536.	1,626.	1,864.
		72"	1 1/2"	RPTDRPC(L/R)7224( ) ( ) ( ) ( )	1,511.	1,562.	1,657.	1,907.
		78"	1 1/2"	RPTDRPC(L/R)7824( ) ( ) ( ) ( )	1,536.	1,591.	1,692.	1,952.
		84"	1 1/2"	RPTDRPC(L/R)8424( ) ( ) ( ) ( )	1,561.	1,618.	1,719.	1,990.
	30"	60"	1 1/2"	RPTDRPC(L/R)6030( ) ( ) ( ) ( )	1,525.	1,577.	1,670.	1,926.
		66"	1 1/2"	RPTDRPC(L/R)6630( ) ( ) ( ) ( )	1,535.	1,590.	1,691.	1,951.
		72"	1 1/2"	RPTDRPC(L/R)7230( ) ( ) ( ) ( )	1,552.	1,606.	1,705.	1,971.
		78"	1 1/2"	RPTDRPC(L/R)7830( ) ( ) ( ) ( )	1,579.	1,638.	1,742.	2,020.
		84"	1 1/2"	RPTDRPC(L/R)8430( ) ( ) ( ) ( )	1,604.	1,665.	1,773.	2,064.
	36"	60"	1 1/2"	RPTDRPC(L/R)6036( ) ( ) ( ) ( )	1,613.	1,674.	1,781.	2,064.
		66"	1 1/2"	RPTDRPC(L/R)6636( ) ( ) ( ) ( )	1,635.	1,699.	1,814.	2,118.
		72"	1 1/2"	RPTDRPC(L/R)7236( ) ( ) ( ) ( )	1,658.	1,725.	1,842.	2,156.
		78"	1 1/2"	RPTDRPC(L/R)7836( ) ( ) ( ) ( )	1,681.	1,747.	1,870.	2,196.
		84"	1 1/2"	RPTDRPC(L/R)8436( ) ( ) ( ) ( )	1,703.	1,770.	1,899.	2,235.

Order Code	Specification Information	Application Notes
Example: <b>RPTDRPC(L/R)6030( ) ( ) ( ) ( )</b>	<i>To order please specify pattern number including:</i>	Modesty sold separately and can be field installed.
<b>R</b> Reff	1. Left or Right hand	Wire chase sold separately.
<b>PT</b> Peninsula	2. Grommet option P=Power Center, PE=Power center plus end grommet	Worksurface stiffeners, recommended to provide additional support for open spans greater than 48" w.
<b>D</b> 1 1/2"	3. Grommet finish Painted or plated	Refer to grommet page for location option.
<b>R</b> Reverse L-leg	4. Worksurface finish L, V1, V2, V3	From users perspective, if the leg is on the right side, the peninsula is classified a "Right Hand" peninsula.
<b>PC</b> Power Center	5. Leg finish Painted or Anodized	
<b>L</b> Left hand/ Right hand	6. Stand-off finish Painted	
<b>30</b> Depth		
<b>40</b> Width		
<b>P</b> Grommet Option		
<b>115</b> Grommet Finish		
<b>114</b> Worksurface Finish		
<b>115</b> Leg Finish		
<b>115</b> Stand-off finish		

Peninsula 1 1/2"  
 Worksurface with Reverse L-leg  
 Simple Stand Off, Rectilinear top

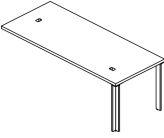
description	d	w	th	pattern no.	L	M/V1	V2	V3
 Peninsula Rectilinear Top  <i>Left hand shown</i>	20"	60"	1 1/2"	RPTDRST(L/R)6020( )( )( )	\$1,351.	\$1,393.	\$1,471.	\$1,681.
		66"	1 1/2"	RPTDRST(L/R)6620( )( )( )	1,362.	1,408.	1,490.	1,704.
		72"	1 1/2"	RPTDRST(L/R)7220( )( )( )	1,390.	1,437.	1,519.	1,745.
		78"	1 1/2"	RPTDRST(L/R)7820( )( )( )	1,397.	1,442.	1,529.	1,759.
		84"	1 1/2"	RPTDRST(L/R)8420( )( )( )	1,428.	1,482.	1,571.	1,814.
	24"	60"	1 1/2"	RPTDRST(L/R)6024( )( )( )	1,400.	1,449.	1,533.	1,763.
		66"	1 1/2"	RPTDRST(L/R)6624( )( )( )	1,414.	1,466.	1,556.	1,794.
		72"	1 1/2"	RPTDRST(L/R)7224( )( )( )	1,441.	1,492.	1,587.	1,837.
		78"	1 1/2"	RPTDRST(L/R)7824( )( )( )	1,466.	1,521.	1,622.	1,882.
		84"	1 1/2"	RPTDRST(L/R)8424( )( )( )	1,491.	1,548.	1,649.	1,920.
	30"	60"	1 1/2"	RPTDRST(L/R)6030( )( )( )	1,455.	1,507.	1,600.	1,856.
		66"	1 1/2"	RPTDRST(L/R)6630( )( )( )	1,465.	1,520.	1,621.	1,881.
		72"	1 1/2"	RPTDRST(L/R)7230( )( )( )	1,482.	1,536.	1,635.	1,901.
		78"	1 1/2"	RPTDRST(L/R)7830( )( )( )	1,509.	1,568.	1,672.	1,950.
		84"	1 1/2"	RPTDRST(L/R)8430( )( )( )	1,534.	1,595.	1,073.	1,994.
	36"	60"	1 1/2"	RPTDRST(L/R)6036( )( )( )	1,543.	1,604.	1,711.	1,994.
		66"	1 1/2"	RPTDRST(L/R)6636( )( )( )	1,565.	1,629.	1,744.	2,048.
		72"	1 1/2"	RPTDRST(L/R)7236( )( )( )	1,588.	1,655.	1,772.	2,086.
		78"	1 1/2"	RPTDRST(L/R)7836( )( )( )	1,611.	1,677.	1,800.	2,126.
		84"	1 1/2"	RPTDRST(L/R)8436( )( )( )	1,633.	1,700.	1,829.	2,165.

Worksurfaces

Order Code	Specification Information	Application Notes
Example: <b>RPTDRST(L/R)6030( )( )( )</b>	<i>To order please specify pattern number including:</i>	Modesty sold separately and can be field installed.
<b>R</b> Reff	1. Left or Right hand	Wire chase sold separately.
<b>PT</b> Peninsula	2. Grommet option S=Stand-off, N=No grommet, E=End grommet, SE=Stand-off and end grommet	Worksurface stiffeners, recommended to provide additional support for open spans greater than 48"w.
<b>D</b> 1 1/2"	3. Grommet finish Painted or plated	Refer to grommet page for location option.
<b>R</b> Reverse L-leg	4. Worksurface finish L, V1, V2, V3	From users perspective, if the leg is on the right side, the peninsula is classified a "Right Hand" peninsula.
<b>ST</b> Stand off	5. Leg finish Painted or Anodized	
<b>L</b> Left hand/ Right hand	6. Stand-off finish Painted	
<b>60</b> Width		
<b>30</b> Depth		
<b>SE</b> Grommet Option		
<b>115</b> Grommet Finish		
<b>114</b> Worksurface Finish		
<b>115</b> Leg Finish		
<b>115</b> Stand-Off Finish		

# Peninsula 1 1/2"

## Worksurface with Reverse L-leg Flush Mount Attachment, Rectilinear top

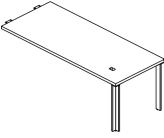
description	d	w	th	pattern no.	L	M/V1	V2	V3
 <p>Left hand shown</p>	20"	48"	1 1/2"	RPTDRFM(L/R)4820( ) ( ) ( ) ( )	\$1,139.	\$1,175.	\$1,244.	\$1,428.
		54"	1 1/2"	RPTDRFM(L/R)5420( ) ( ) ( ) ( )	1,156.	1,193.	1,268.	1,463.
		60"	1 1/2"	RPTDRFM(L/R)6020( ) ( ) ( ) ( )	1,191.	1,233.	1,311.	1,521.
		66"	1 1/2"	RPTDRFM(L/R)6620( ) ( ) ( ) ( )	1,202.	1,248.	1,330.	1,544.
		72"	1 1/2"	RPTDRFM(L/R)7220( ) ( ) ( ) ( )	1,230.	1,277.	1,359.	1,585.
		78"	1 1/2"	RPTDRFM(L/R)7820( ) ( ) ( ) ( )	1,237.	1,282.	1,369.	1,599.
		84"	1 1/2"	RPTDRFM(L/R)8420( ) ( ) ( ) ( )	1,268.	1,322.	1,411.	1,654.
		24"	48"	1 1/2"	RPTDRFM(L/R)4824( ) ( ) ( ) ( )	1,170.	1,217.	1,291.
54"	1 1/2"		RPTDRFM(L/R)5424( ) ( ) ( ) ( )	1,202.	1,248.	1,330.	1,544.	
60"	1 1/2"		RPTDRFM(L/R)6024( ) ( ) ( ) ( )	1,240.	1,289.	1,373.	1,603.	
66"	1 1/2"		RPTDRFM(L/R)6624( ) ( ) ( ) ( )	1,254.	1,306.	1,396.	1,634.	
72"	1 1/2"		RPTDRFM(L/R)7224( ) ( ) ( ) ( )	1,281.	1,332.	1,427.	1,677.	
78"	1 1/2"		RPTDRFM(L/R)7824( ) ( ) ( ) ( )	1,306.	1,361.	1,462.	1,722.	
84"	1 1/2"		RPTDRFM(L/R)8424( ) ( ) ( ) ( )	1,331.	1,388.	1,489.	1,760.	
30"	48"		1 1/2"	RPTDRFM(L/R)4830( ) ( ) ( ) ( )	1,249.	1,301.	1,384.	1,617.
	54"	1 1/2"	RPTDRFM(L/R)5430( ) ( ) ( ) ( )	1,272.	1,324.	1,412.	1,656.	
	60"	1 1/2"	RPTDRFM(L/R)6030( ) ( ) ( ) ( )	1,295.	1,347.	1,440.	1,696.	
	66"	1 1/2"	RPTDRFM(L/R)6630( ) ( ) ( ) ( )	1,305.	1,360.	1,461.	1,721.	
	72"	1 1/2"	RPTDRFM(L/R)7230( ) ( ) ( ) ( )	1,322.	1,376.	1,475.	1,741.	
	78"	1 1/2"	RPTDRFM(L/R)7830( ) ( ) ( ) ( )	1,349.	1,408.	1,512.	1,790.	
	84"	1 1/2"	RPTDRFM(L/R)8430( ) ( ) ( ) ( )	1,374.	1,435.	1,543.	1,834.	
	36"	48"	1 1/2"	RPTDRFM(L/R)4836( ) ( ) ( ) ( )	1,338.	1,399.	1,495.	1,755.
54"		1 1/2"	RPTDRFM(L/R)5436( ) ( ) ( ) ( )	1,360.	1,421.	1,523.	1,794.	
60"		1 1/2"	RPTDRFM(L/R)6036( ) ( ) ( ) ( )	1,383.	1,444.	1,551.	1,834.	
66"		1 1/2"	RPTDRFM(L/R)6636( ) ( ) ( ) ( )	1,405.	1,469.	1,584.	1,888.	
72"		1 1/2"	RPTDRFM(L/R)7236( ) ( ) ( ) ( )	1,428.	1,495.	1,612.	1,926.	
78"		1 1/2"	RPTDRFM(L/R)7836( ) ( ) ( ) ( )	1,451.	1,517.	1,640.	1,966.	
84"		1 1/2"	RPTDRFM(L/R)8436( ) ( ) ( ) ( )	1,473.	1,540.	1,669.	2,005.	

Order Code	Specification Information	Application Notes
Example: <b>RPTDRFM(L/R)4830( ) ( ) ( )</b>	<i>To order please specify pattern number including:</i>	Modesty sold separately and can be field installed.
<b>R</b> Reff	1. Left or Right hand	Wire chase sold separately.
<b>PT</b> Peninsula	2. Grommet option	Worksurface stiffeners, recommended to provide additional support for open spans greater than 48" w.
<b>D</b> 1 1/2"	E=End, N=No grommet, M=Mid. grommet	Refer to grommet page for location option.
<b>R</b> Reverse L-leg	3. Grommet finish	From users perspective, if the leg is on the right side, the peninsula is classified a "Right Hand" peninsula.
<b>FM</b> Flush Mount Attachment Leg	4. Worksurface finish	
<b>L</b> Left hand/ Right hand	L, V1, V2, V3	
<b>48</b> Width	5. Leg finish	
<b>30</b> Depth	Painted or Anodized	
<b>M</b> Grommet Option		
<b>115</b> Grommet Finish		
<b>114</b> Worksurface Finish		
<b>115</b> Leg Finish		

# Peninsula 1 1/2"

## Worksurface with Soft Rectangular Leg Stand Off with Power Center, Rectilinear top

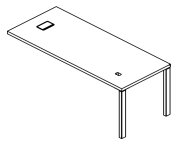
description	d	w	th	pattern number	L	M/V1	V2	V3
 <p>Left hand shown</p>	30"	60"	1 1/2"	RPTDSPC(L/R)6030( ) ( ) ( ) ( )	\$1,570.	\$1,622.	\$1,715.	\$1,971.
		66"	1 1/2"	RPTDSPC(L/R)6630( ) ( ) ( ) ( )	1,580.	1,635.	1,736.	1,996.
		72"	1 1/2"	RPTDSPC(L/R)7230( ) ( ) ( ) ( )	1,597.	1,651.	1,750.	2,016.
		78"	1 1/2"	RPTDSPC(L/R)7830( ) ( ) ( ) ( )	1,624.	1,683.	1,787.	2,065.
		84"	1 1/2"	RPTDSPC(L/R)8430( ) ( ) ( ) ( )	1,649.	1,710.	1,818.	2,109.
	36"	60"	1 1/2"	RPTDSPC(L/R)6036( ) ( ) ( ) ( )	1,658.	1,719.	1,826.	2,109.
		66"	1 1/2"	RPTDSPC(L/R)6636( ) ( ) ( ) ( )	1,680.	1,744.	1,859.	2,163.
		72"	1 1/2"	RPTDSPC(L/R)7236( ) ( ) ( ) ( )	1,703.	1,770.	1,887.	2,201.
		78"	1 1/2"	RPTDSPC(L/R)7836( ) ( ) ( ) ( )	1,726.	1,792.	1,915.	2,241.
		84"	1 1/2"	RPTDSPC(L/R)8436( ) ( ) ( ) ( )	1,748.	1,815.	1,944.	2,280.

Worksurfaces

Order Code	Specification Information	Application Notes
Example: <b>RPTDSPC(L/R)6030( ) ( ) ( ) ( )</b>	<i>To order please specify pattern number including:</i>	Modesty sold separately and can be field installed.
<b>R</b> Reff	1. Left or Right hand	Wire chase sold separately.
<b>PT</b> Peninsula	2. Grommet option P=Power Center PE=Power center and end grommet	Worksurface stiffeners, recommended to provide additional support for open spans greater than 48"w.
<b>D</b> 1 1/2"	3. Grommet finish Painted or plated	Refer to grommet page for location option.
<b>S</b> Soft Rectangular Leg	4. Worksurface finish L, V1, V2, V3	From users perspective, if the leg is on the right side, the peninsula is classified a "Right Hand" peninsula.
<b>PC</b> Power Center	5. Leg finish Painted or Anodized	
<b>L</b> Left hand/ Right hand	6. Stand-off finish Painted	
<b>60</b> Width		
<b>30</b> Depth		
<b>P</b> Grommet Option		
<b>115</b> Grommet Finish		
<b>114</b> Worksurface Finish		
<b>115</b> Leg Finish		
<b>115</b> Stand-Off Finish		

Peninsula 1 1/2"  
 Worksurface with Soft Rectangular Leg  
 Simple Stand Off, Rectilinear top

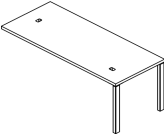
description	d	w	th	pattern no.	L	M/V1	V2	V3
 Peninsula Rectilinear Top  <i>Left hand shown</i>	30"	60"	1 1/2"	RPTDSST(L/R)6030( ) ( ) ( ) ( )	\$1,500.	\$1,552.	\$1,645.	\$1,901.
		66"	1 1/2"	RPTDSST(L/R)6630( ) ( ) ( ) ( )	1,510.	1,565.	1,666.	1,926.
		72"	1 1/2"	RPTDSST(L/R)7230( ) ( ) ( ) ( )	1,527.	1,581.	1,680.	1,946.
		78"	1 1/2"	RPTDSST(L/R)7830( ) ( ) ( ) ( )	1,554.	1,613.	1,717.	1,995.
		84"	1 1/2"	RPTDSST(L/R)8430( ) ( ) ( ) ( )	1,579.	1,640.	1,748.	2,039.
	36"	60"	1 1/2"	RPTDSST(L/R)6036( ) ( ) ( ) ( )	1,588.	1,649.	1,756.	2,039.
		66"	1 1/2"	RPTDSST(L/R)6636( ) ( ) ( ) ( )	1,610.	1,674.	1,789.	2,093.
		72"	1 1/2"	RPTDSST(L/R)7236( ) ( ) ( ) ( )	1,633.	1,700.	1,817.	2,131.
		78"	1 1/2"	RPTDSST(L/R)7836( ) ( ) ( ) ( )	1,656.	1,722.	1,845.	2,171.
		84"	1 1/2"	RPTDSST(L/R)8436( ) ( ) ( ) ( )	1,678.	1,745.	1,874.	2,210.

Order Code	Specification Information	Application Notes
Example: <b>RPTDSST(L/R)6030( ) ( ) ( ) ( )</b>	<i>To order please specify pattern number including:</i>	Modesty sold separately and can be field installed.
<b>R</b> Reff	1. Left or Right hand	Wire chase sold separately.
<b>PT</b> Peninsula	2. Grommet option S=Stand-off N=No grommet E=End grommet SE=Stand-off and end grommet	Worksurface stiffeners, recommended to provide additional support for open spans greater than 48" w.
<b>D</b> 1 1/2"	3. Grommet finish Painted or plated	Refer to grommet page for location option.
<b>S</b> Soft Rectangular Leg	4. Worksurface finish L, V1, V2, V3	From users perspective, if the leg is on the right side, the peninsula is classified a "Right Hand" peninsula.
<b>ST</b> Stand Off	5. Leg finish Painted or Anodized	
<b>L</b> Left hand/ Right hand	6. Stand-off finish Painted	
<b>60</b> Width		
<b>30</b> Depth		
<b>E</b> Grommet Option		
<b>115</b> Grommet Finish		
<b>114</b> Worksurface Finish		
<b>115</b> Leg Finish		
<b>115</b> Stand-Off Finish		

Peninsula 1 1/2"  
 Worksurface with Soft Rectangular Leg  
 Flush Mount Attachment, Rectilinear top

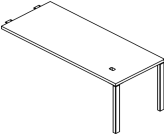
description	d	w	th	pattern no.	L	M/V1	V2	V3
 Left hand shown	30"	48"	1 1/2"	RPTDSFM(L/R)4830( ) ( ) ( ) ( )	\$1,294.	\$1,346.	\$1,429.	\$1,662.
		54"	1 1/2"	RPTDSFM(L/R)5430( ) ( ) ( ) ( )	1,317.	1,369.	1,457.	1,701.
		60"	1 1/2"	RPTDSFM(L/R)6030( ) ( ) ( ) ( )	1,340.	1,392.	1,485.	1,741.
		66"	1 1/2"	RPTDSFM(L/R)6630( ) ( ) ( ) ( )	1,350.	1,405.	1,506.	1,766.
		72"	1 1/2"	RPTDSFM(L/R)7230( ) ( ) ( ) ( )	1,367.	1,421.	1,520.	1,786.
		78"	1 1/2"	RPTDSFM(L/R)7830( ) ( ) ( ) ( )	1,394.	1,453.	1,557.	1,835.
		84"	1 1/2"	RPTDSFM(L/R)8430( ) ( ) ( ) ( )	1,419.	1,480.	1,588.	1,879.
		36"	48"	1 1/2"	RPTDSFM(L/R)4836( ) ( ) ( ) ( )	1,383.	1,444.	1,540.
	54"		1 1/2"	RPTDSFM(L/R)5436( ) ( ) ( ) ( )	1,405.	1,466.	1,568.	1,839.
	60"		1 1/2"	RPTDSFM(L/R)6036( ) ( ) ( ) ( )	1,428.	1,489.	1,596.	1,879.
	66"		1 1/2"	RPTDSFM(L/R)6636( ) ( ) ( ) ( )	1,450.	1,514.	1,629.	1,933.
	72"		1 1/2"	RPTDSFM(L/R)7236( ) ( ) ( ) ( )	1,473.	1,540.	1,657.	1,971.
	78"		1 1/2"	RPTDSFM(L/R)7836( ) ( ) ( ) ( )	1,496.	1,562.	1,685.	2,011.
	84"		1 1/2"	RPTDSFM(L/R)8436( ) ( ) ( ) ( )	1,518.	1,585.	1,714.	2,050.

Worksurfaces

Order Code	Specification Information	Application Notes
Example: <b>RPTDSFM(L/R)4830( ) ( ) ( ) ( )</b>	<i>To order please specify pattern number including:</i>	Modesty sold separately and can be field installed.
<b>R</b> Reff	1. Left or Right hand	Wire chase sold separately.
<b>PT</b> Peninsula	2. Grommet option	Worksurface stiffeners, recommended to provide additional support for open spans greater than 48" w.
<b>D</b> 1 1/2"	E=End N=No grommet M=Mid. grommet	Refer to grommet page for location option.
<b>S</b> Soft Rectangular Leg	3. Grommet finish Painted or plated	From users perspective, if the leg is on the right side, the peninsula is classified a "Right Hand" peninsula.
<b>FM</b> Flush Mount Attachment Platef	4. Worksurface finish L, V1, V2, V3	
<b>L</b> Left hand/ Right hand	5. Leg finish Painted or Anodized	
<b>48</b> Width		
<b>30</b> Depth		
<b>E</b> Grommet Option		
<b>115</b> Grommet Finish		
<b>114</b> Worksurface Finish		
<b>115</b> Leg Finish		

# Peninsula 1 1/2"

Reff Profiles

## Worksurface with Open Frame Leg Stand-Off with Power Center, Rectilinear top

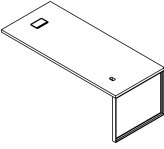
description	d	w	th	pattern no.	L	M/V1	V2	V3
 <p>Left hand shown</p>	20"	60"	1 1/2"	RPTDOPC(L/R)6020( ) ( ) ( ) ( )	\$1,491.	\$1,533.	\$1,611.	\$1,821.
		66"	1 1/2"	RPTDOPC(L/R)6620( ) ( ) ( ) ( )	1,502.	1,548.	1,630.	1,844.
		72"	1 1/2"	RPTDOPC(L/R)7220( ) ( ) ( ) ( )	1,530.	1,577.	1,659.	1,885.
		78"	1 1/2"	RPTDOPC(L/R)7820( ) ( ) ( ) ( )	1,537.	1,582.	1,669.	1,899.
		84"	1 1/2"	RPTDOPC(L/R)8420( ) ( ) ( ) ( )	1,568.	1,622.	1,711.	1,954.
	24"	60"	1 1/2"	RPTDOPC(L/R)6024( ) ( ) ( ) ( )	1,540.	1,589.	1,673.	1,903.
		66"	1 1/2"	RPTDOPC(L/R)6624( ) ( ) ( ) ( )	1,554.	1,606.	1,696.	1,934.
		72"	1 1/2"	RPTDOPC(L/R)7224( ) ( ) ( ) ( )	1,581.	1,632.	1,727.	1,977.
		78"	1 1/2"	RPTDOPC(L/R)7824( ) ( ) ( ) ( )	1,606.	1,661.	1,762.	2,022.
		84"	1 1/2"	RPTDOPC(L/R)8424( ) ( ) ( ) ( )	1,631.	1,688.	1,789.	2,060.
	30"	60"	1 1/2"	RPTDOPC(L/R)6030( ) ( ) ( ) ( )	1,595.	1,647.	1,740.	1,996.
		66"	1 1/2"	RPTDOPC(L/R)6630( ) ( ) ( ) ( )	1,605.	1,660.	1,761.	2,021.
		72"	1 1/2"	RPTDOPC(L/R)7230( ) ( ) ( ) ( )	1,622.	1,676.	1,775.	2,041.
		78"	1 1/2"	RPTDOPC(L/R)7830( ) ( ) ( ) ( )	1,649.	1,708.	1,812.	2,090.
		84"	1 1/2"	RPTDOPC(L/R)8430( ) ( ) ( ) ( )	1,674.	1,735.	1,843.	2,134.
	36"	60"	1 1/2"	RPTDOPC(L/R)6036( ) ( ) ( ) ( )	1,683.	1,744.	1,851.	2,134.
		66"	1 1/2"	RPTDOPC(L/R)6636( ) ( ) ( ) ( )	1,705.	1,769.	1,884.	2,188.
		72"	1 1/2"	RPTDOPC(L/R)7236( ) ( ) ( ) ( )	1,728.	1,795.	1,912.	2,226.
		78"	1 1/2"	RPTDOPC(L/R)7836( ) ( ) ( ) ( )	1,751.	1,817.	1,940.	2,266.
		84"	1 1/2"	RPTDOPC(L/R)8436( ) ( ) ( ) ( )	1,773.	1,840.	1,969.	2,305.

Order Code	Specification Information	Application Notes
Example: <b>RPTDOPC(L/R)6030( ) ( ) ( ) ( )</b>	<i>To order please specify pattern number including:</i>	Modesty sold separately and can be field installed.
<b>R</b> Reff	1. Left or Right hand	Wire chase sold separately.
<b>PT</b> Peninsula	2. Grommet option P=Power Center PE=Power center and end grommet	Worksurface stiffeners, recommended to provide additional support for open spans greater than 48"w.
<b>D</b> 1 1/2"	3. Grommet finish Painted or plated	Refer to grommet page for location option.
<b>O</b> Open Frame Leg	4. Worksurface finish L, V1, V2, V3	From users perspective, if the leg is on the right side, the peninsula is classified a "Right Hand" peninsula.
<b>PC</b> Power Center	5. Leg finish Painted or Anodized	
<b>L</b> Left hand/ Right hand	6. Stand-off finish Painted	
<b>60</b> Width		
<b>30</b> Depth		
<b>P</b> Grommet Option		
<b>115</b> Grommet Finish		
<b>114</b> Worksurface Finish		
<b>115</b> Leg Finish		
<b>115</b> Stand-Off Finish		

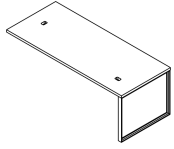

Peninsula 1 1/2"  
 Worksurface with Open Frame Leg  
 Simple Stand-Off, Rectilinear top

description	d	w	th	pattern no.	L	M/V1	V2	V3
Peninsula, Rectilinear Top   Left hand shown	36"	60"	1 1/2"	RPTDOST(L/R)6036( ) ( ) ( ) ( )	\$1,613.	\$1,674.	\$1,781.	\$2,064.
		66"	1 1/2"	RPTDOST(L/R)6636( ) ( ) ( ) ( )	1,635.	1,699.	1,814.	2,118.
		72"	1 1/2"	RPTDOST(L/R)7236( ) ( ) ( ) ( )	1,658.	1,725.	1,842.	2,156.
		78"	1 1/2"	RPTDOST(L/R)7836( ) ( ) ( ) ( )	1,681.	1,747.	1,870.	2,196.
		84"	1 1/2"	RPTDOST(L/R)8436( ) ( ) ( ) ( )	1,703.	1,770.	1,899.	2,235.
	30"	60"	1 1/2"	RPTDOST(L/R)6030( ) ( ) ( ) ( )	1,525.	1,577.	1,670.	1,926.
		66"	1 1/2"	RPTDOST(L/R)6630( ) ( ) ( ) ( )	1,535.	1,590.	1,691.	1,951.
		72"	1 1/2"	RPTDOST(L/R)7230( ) ( ) ( ) ( )	1,552.	1,606.	1,705.	1,971.
		78"	1 1/2"	RPTDOST(L/R)7830( ) ( ) ( ) ( )	1,579.	1,638.	1,742.	2,020.
		84"	1 1/2"	RPTDOST(L/R)8430( ) ( ) ( ) ( )	1,604.	1,665.	1,773.	2,064.

Order Code	Specification Information	Application Notes
Example: <b>RPTDOST(L/R)6030( ) ( ) ( ) ( )</b>	<i>To order please specify pattern number including:</i>	Modesty sold separately and can be field installed.
<b>R</b> Reff	1. Left or Right hand	Wire chase sold separately.
<b>PT</b> Peninsula	2. Grommet option M=Mid. grommet N=No grommet S=Stand-off SE=Stand-off and end location	Worksurface stiffeners, recommended to provide additional support for open spans greater than 48" w.
<b>D</b> 1 1/2"	3. Grommet finish Painted or plated	Refer to grommet page for location option.
<b>O</b> Open Frame Leg	4. Worksurface finish L, V1, V2, V3	From users perspective, if the leg is on the right side, the peninsula is classified a "Right Hand" peninsula.
<b>ST</b> Stand-Off	5. Leg finish Painted or Anodized	
<b>L</b> Left hand/ Right hand	6. Stand-off finish Painted	
<b>60</b> Width		
<b>30</b> Depth		
<b>S</b> Grommet Option		
<b>115</b> Grommet Finish		
<b>114</b> Worksurface Finish		
<b>115</b> Leg Finish		
<b>115</b> Stand-Off Finish		

Peninsula 1 1/2"  
 Worksurface with Open Frame Leg  
 Flush Mount Attachment, Rectilinear top

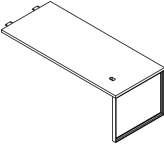
description	d	w	th	pattern no.	L	M/V1	V2	V3
 Peninsula, Rectilinear Top	20"	48"	1 1/2"	RPTDOFM(L/R)4820( ) ( ) ( ) ( )	\$1,209.	\$1,245.	\$1,314.	\$1,498.
		54"	1 1/2"	RPTDOFM(L/R)5420( ) ( ) ( ) ( )	1,226.	1,263.	1,338.	1,533.
		60"	1 1/2"	RPTDOFM(L/R)6020( ) ( ) ( ) ( )	1,261.	1,303.	1,381.	1,591.
		66"	1 1/2"	RPTDOFM(L/R)6620( ) ( ) ( ) ( )	1,272.	1,318.	1,400.	1,614.
		72"	1 1/2"	RPTDOFM(L/R)7220( ) ( ) ( ) ( )	1,300.	1,347.	1,429.	1,655.
		78"	1 1/2"	RPTDOFM(L/R)7820( ) ( ) ( ) ( )	1,307.	1,352.	1,439.	1,669.
		84"	1 1/2"	RPTDOFM(L/R)8420( ) ( ) ( ) ( )	1,338.	1,392.	1,481.	1,724.
		24"	48"	1 1/2"	RPTDOFM(L/R)4824( ) ( ) ( ) ( )	1,240.	1,287.	1,361.
54"	1 1/2"		RPTDOFM(L/R)5424( ) ( ) ( ) ( )	1,272.	1,318.	1,400.	1,614.	
60"	1 1/2"		RPTDOFM(L/R)6024( ) ( ) ( ) ( )	1,310.	1,359.	1,443.	1,673.	
66"	1 1/2"		RPTDOFM(L/R)6624( ) ( ) ( ) ( )	1,324.	1,376.	1,466.	1,704.	
72"	1 1/2"		RPTDOFM(L/R)7224( ) ( ) ( ) ( )	1,351.	1,402.	1,497.	1,747.	
78"	1 1/2"		RPTDOFM(L/R)7824( ) ( ) ( ) ( )	1,376.	1,431.	1,532.	1,792.	
84"	1 1/2"		RPTDOFM(L/R)8424( ) ( ) ( ) ( )	1,401.	1,458.	1,559.	1,830.	
30"	48"		1 1/2"	RPTDOFM(L/R)4830( ) ( ) ( ) ( )	1,319.	1,371.	1,454.	1,687.
	54"	1 1/2"	RPTDOFM(L/R)5430( ) ( ) ( ) ( )	1,342.	1,394.	1,482.	1,726.	
	60"	1 1/2"	RPTDOFM(L/R)6030( ) ( ) ( ) ( )	1,365.	1,417.	1,510.	1,766.	
	66"	1 1/2"	RPTDOFM(L/R)6630( ) ( ) ( ) ( )	1,375.	1,430.	1,531.	1,791.	
	72"	1 1/2"	RPTDOFM(L/R)7230( ) ( ) ( ) ( )	1,392.	1,446.	1,545.	1,811.	
	78"	1 1/2"	RPTDOFM(L/R)7830( ) ( ) ( ) ( )	1,419.	1,478.	1,582.	1,860.	
	84"	1 1/2"	RPTDOFM(L/R)8430( ) ( ) ( ) ( )	1,444.	1,505.	1,613.	1,904.	
	36"	48"	1 1/2"	RPTDOFM(L/R)4836( ) ( ) ( ) ( )	1,408.	1,469.	1,565.	1,825.
54"		1 1/2"	RPTDOFM(L/R)5436( ) ( ) ( ) ( )	1,430.	1,491.	1,593.	1,864.	
60"		1 1/2"	RPTDOFM(L/R)6036( ) ( ) ( ) ( )	1,463.	1,514.	1,621.	1,904.	
66"		1 1/2"	RPTDOFM(L/R)6636( ) ( ) ( ) ( )	1,475.	1,539.	1,654.	1,958.	
72"		1 1/2"	RPTDOFM(L/R)7236( ) ( ) ( ) ( )	1,498.	1,565.	1,682.	1,996.	
78"		1 1/2"	RPTDOFM(L/R)7836( ) ( ) ( ) ( )	1,521.	1,587.	1,710.	2,036.	
84"		1 1/2"	RPTDOFM(L/R)8436( ) ( ) ( ) ( )	1,543.	1,610.	1,739.	2,075.	

Left hand shown

Order Code	Specification Information	Application Notes
Example: <b>RPTDOFM(L/R)4830( ) ( ) ( )</b>	To order please specify pattern number including:	Modesty sold separately and can be field installed.
<b>R</b> Reff	1. Left or Right hand	Wire chase sold separately.
<b>PT</b> Peninsula	2. Grommet option	Worksurface stiffeners, recommended to provide additional support for open spans greater than 48" w.
<b>D</b> 1 1/2"	E=End M=Mid. grommet N=No grommet	Refer to grommet page for location option.
<b>O</b> Open Frame Leg	3. Grommet finish	From users perspective, if the leg is on the right side, the peninsula is classified a "Right Hand" peninsula.
<b>FM</b> Flush Mount Attachment Plate	4. Worksurface finish	
<b>L</b> Left hand/ Right hand	L, V1, V2, V3	
<b>48</b> Width	5. Leg finish	
<b>30</b> Depth	Painted or Anodized	
<b>E</b> Grommet Option		
<b>115</b> Grommet Finish		
<b>114</b> Worksurface Finish		
<b>115</b> Leg Finish		

# Peninsula 1 1/2"

## Worksurface with Column Leg

### Stand-Off with Power Center, Asymmetrical and Symmetrical Bullet top

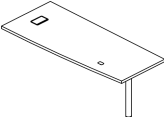
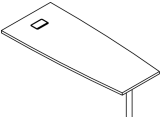
description	d	w	th	pattern no.	L	V1	V2	V3
 Peninsula, Asymmetrical Bullet Top  <i>Left handed peninsula shown</i>	30"	60"	1 1/2"	RATDCPC(L/R)6030( ) ( ) ( ) ( )	\$1,641.	\$1,729.	\$1,809.	\$2,122.
		66"	1 1/2"	RATDCPC(L/R)6630( ) ( ) ( ) ( )	1,661.	1,750.	1,836.	2,175.
		66"	1 1/2"	RATDCPC(L/R)7230( ) ( ) ( ) ( )	1,688.	1,778.	1,871.	2,237.
		78"	1 1/2"	RATDCPC(L/R)7830( ) ( ) ( ) ( )	1,707.	1,799.	1,899.	2,292.
		84"	1 1/2"	RATDCPC(L/R)8430( ) ( ) ( ) ( )	1,733.	1,826.	1,933.	2,353.
Peninsula, Asymmetrical Bullet Top  36"	60"	1 1/2"	RATDCPC(L/R)6036( ) ( ) ( ) ( )	1,686.	1,774.	1,867.	2,225.	
	66"	1 1/2"	RATDCPC(L/R)6636( ) ( ) ( ) ( )	1,709.	1,798.	1,899.	2,289.	
	72"	1 1/2"	RATDCPC(L/R)7236( ) ( ) ( ) ( )	1,739.	1,829.	1,938.	2,358.	
	78"	1 1/2"	RATDCPC(L/R)7836( ) ( ) ( ) ( )	1,761.	1,853.	1,971.	2,422.	
	84"	1 1/2"	RATDCPC(L/R)8436( ) ( ) ( ) ( )	1,784.	1,877.	2,002.	2,483.	
 Peninsula, Symmetrical Bullet Top  <i>Left hand shown</i>	30"	60"	1 1/2"	RSTDCPC(L/R)6030( ) ( ) ( ) ( )	1,851.	1,969.	2,048.	2,361.
		66"	1 1/2"	RSTDCPC(L/R)6630( ) ( ) ( ) ( )	1,876.	1,996.	2,083.	2,422.
		72"	1 1/2"	RSTDCPC(L/R)7230( ) ( ) ( ) ( )	1,896.	2,017.	2,110.	2,477.
		78"	1 1/2"	RSTDCPC(L/R)7830( ) ( ) ( ) ( )	1,916.	2,038.	2,138.	2,531.
		84"	1 1/2"	RSTDCPC(L/R)8430( ) ( ) ( ) ( )	1,942.	2,066.	2,172.	2,592.
Peninsula, Symmetrical Bullet Top  36"	60"	1 1/2"	RSTDCPC(L/R)6036( ) ( ) ( ) ( )	1,892.	2,013.	2,106.	2,464.	
	66"	1 1/2"	RSTDCPC(L/R)6636( ) ( ) ( ) ( )	1,916.	2,038.	2,139.	2,528.	
	72"	1 1/2"	RSTDCPC(L/R)7236( ) ( ) ( ) ( )	1,945.	2,069.	2,178.	2,597.	
	78"	1 1/2"	RSTDCPC(L/R)7836( ) ( ) ( ) ( )	1,967.	2,093.	2,210.	2,661.	
	84"	1 1/2"	RSTDCPC(L/R)8436( ) ( ) ( ) ( )	1,990.	2,117.	2,242.	2,723.	

Worksurfaces

#### Order Code

Example:	<b>RATDCPC(L/R)6030( ) ( ) ( ) ( )</b>
<b>R</b>	Reff
<b>AT</b>	Asymmetrical Top
<b>D</b>	1 1/2"
<b>C</b>	Column Leg
<b>PC</b>	Power Center
<b>L</b>	Left hand/ Right hand
<b>60</b>	Width
<b>30</b>	Depth
<b>115</b>	Grommet Finish
<b>114</b>	Worksurface Finish
<b>115</b>	Leg Finish
<b>115</b>	Stand-off Finish

#### Specification Information

To order please specify pattern number including:

- Grommet finish: Painted or Plated
- Top finish: L, V1, V2, V3
- Leg finish: Painted or Plated
- Stand-off finish: Painted

Grommet type: P only

#### Application Notes

Modesty sold separately and can be field installed.

Wire chase sold separately.

Worksurface stiffeners, recommended to provide additional support for open spans greater than 48" w.

Refer to grommet page for location option.

From users perspective, if the leg is on the right side, the peninsula is classified a "Right Hand" peninsula.

Peninsula worksurfaces with power center do not come with Electrical Components.

For electrical components please refer to page 424.

# Peninsula 1 1/2"

## Worksurface with Column Leg

### Simple Stand-Off, Asymmetrical and Symmetrical Bullet top

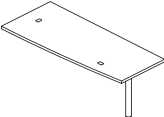
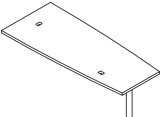
description	d	w	th	pattern no.	L	M/V1	V2	V3
 <p>Left handed peninsula shown</p>	30"	60"	1 1/2"	<b>RATDCST(L/R)6030</b> ( ) ( ) ( ) ( )	\$1,455.	\$1,543.	\$1,623.	\$1,936.
		66"	1 1/2"	<b>RATDCST(L/R)6630</b> ( ) ( ) ( ) ( )	1,475.	1,564.	1,650.	1,989.
		72"	1 1/2"	<b>RATDCST(L/R)7230</b> ( ) ( ) ( ) ( )	1,502.	1,592.	1,685.	2,051.
		78"	1 1/2"	<b>RATDCST(L/R)7830</b> ( ) ( ) ( ) ( )	1,521.	1,613.	1,713.	2,106.
		84"	1 1/2"	<b>RATDCST(L/R)8430</b> ( ) ( ) ( ) ( )	1,547.	1,640.	1,747.	2,167.
	36"	60"	1 1/2"	<b>RATDCST(L/R)6036</b> ( ) ( ) ( ) ( )	1,500.	1,588.	1,681.	2,039.
		66"	1 1/2"	<b>RATDCST(L/R)6636</b> ( ) ( ) ( ) ( )	1,523.	1,612.	1,713.	2,103.
		72"	1 1/2"	<b>RATDCST(L/R)7236</b> ( ) ( ) ( ) ( )	1,553.	1,643.	1,752.	2,172.
		78"	1 1/2"	<b>RATDCST(L/R)7836</b> ( ) ( ) ( ) ( )	1,575.	1,667.	1,785.	2,236.
		84"	1 1/2"	<b>RATDCST(L/R)8436</b> ( ) ( ) ( ) ( )	1,598.	1,691.	1,816.	2,297.
 <p>Left hand shown</p>	30"	60"	1 1/2"	<b>RSTDCST(L/R)6030</b> ( ) ( ) ( ) ( )	1,729.	1,839.	1,919.	2,231.
		66"	1 1/2"	<b>RSTDCST(L/R)6630</b> ( ) ( ) ( ) ( )	1,747.	1,859.	1,946.	2,285.
		72"	1 1/2"	<b>RSTDCST(L/R)7230</b> ( ) ( ) ( ) ( )	1,774.	1,887.	1,981.	2,347.
		78"	1 1/2"	<b>RSTDCST(L/R)7830</b> ( ) ( ) ( ) ( )	1,794.	1,909.	2,009.	2,402.
		84"	1 1/2"	<b>RSTDCST(L/R)8430</b> ( ) ( ) ( ) ( )	1,820.	1,936.	2,043.	2,463.
	36"	60"	1 1/2"	<b>RSTDCST(L/R)6036</b> ( ) ( ) ( ) ( )	1,771.	1,884.	1,976.	2,335.
		66"	1 1/2"	<b>RSTDCST(L/R)6636</b> ( ) ( ) ( ) ( )	1,794.	1,908.	2,009.	2,399.
		72"	1 1/2"	<b>RSTDCST(L/R)7236</b> ( ) ( ) ( ) ( )	1,823.	1,939.	2,048.	2,467.
		78"	1 1/2"	<b>RSTDCST(L/R)7836</b> ( ) ( ) ( ) ( )	1,845.	1,936.	2,080.	2,532.
		84"	1 1/2"	<b>RSTDCST(L/R)8436</b> ( ) ( ) ( ) ( )	1,868.	1,987.	2,112.	2,593.

Order Code	Specification Information	Application Notes
Example: <b>RATDCST (L/R)6030</b>	<i>To order please specify pattern number including:</i>	Modesty sold separately and can be field installed.
<b>R</b> Reff	1. Grommet option: N=No grommet E=End grommet S=Grommet over Stand-Off SE=Grommet over Stand-off plus end grommet	Wire chase sold separately.
<b>AT</b> Asymmetrical Top	2. Grommet finish: Painted or Plated	Worksurface stiffeners, recommended to provide additional support for open spans greater than 48" w.
<b>D</b> 1 1/2"	3. Top finish: L, V1, V2, V3	Refer to grommet page for location option.
<b>C</b> Column Leg	4. Leg finish: Painted or Plated	From users perspective, if the leg is on the right side, the peninsula is classified a "Right Hand" peninsula.
<b>ST</b> Stand-Off	5. Stand-off finish: Painted	Peninsula worksurfaces with power center do not come with Electrical Components.
<b>L/R</b> Left/Right Hand		For electrical components please refer to page 424.
<b>60</b> Width		
<b>30</b> Depth		
<b>N</b> Grommet Option		
<b>115</b> Grommet Finish		
<b>V316</b> Worksurface Finish		
<b>115</b> Leg Finish		
<b>115</b> Stand-Off Finish		

Worksurface with Column Leg

Flush Mount Attachment, Asymmetrical and Symmetrical Bullet top

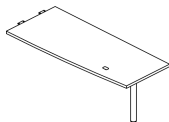
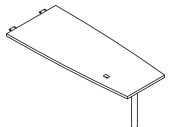
description	d	w	th	pattern no.	L	V1	V2	V3
 <p>Left handed peninsula shown</p>	30"	48"	1 1/2"	RATDCFM(L/R)4830( ) ( ) ( )	\$1,302.	\$1,385.	\$1,451.	\$1,710.
		54"	1 1/2"	RATDCFM(L/R)5430( ) ( ) ( )	1,321.	1,405.	1,478.	1,764.
		60"	1 1/2"	RATDCFM(L/R)6030( ) ( ) ( )	1,371.	1,459.	1,539.	1,852.
		66"	1 1/2"	RATDCFM(L/R)6630( ) ( ) ( )	1,391.	1,480.	1,566.	1,905.
		72"	1 1/2"	RATDCFM(L/R)7230( ) ( ) ( )	1,418.	1,508.	1,601.	1,967.
		78"	1 1/2"	RATDCFM(L/R)7830( ) ( ) ( )	1,437.	1,529.	1,629.	2,022.
		84"	1 1/2"	RATDCFM(L/R)8430( ) ( ) ( )	1,463.	1,556.	1,663.	2,083.
	36"	48"	1 1/2"	RATDCFM(L/R)4836( ) ( ) ( )	1,338.	1,423.	1,499.	1,796.
		54"	1 1/2"	RATDCFM(L/R)5436( ) ( ) ( )	1,360.	1,447.	1,532.	1,860.
		60"	1 1/2"	RATDCFM(L/R)6036( ) ( ) ( )	1,414.	1,504.	1,597.	1,955.
		66"	1 1/2"	RATDCFM(L/R)6636( ) ( ) ( )	1,436.	1,528.	1,629.	2,019.
		72"	1 1/2"	RATDCFM(L/R)7236( ) ( ) ( )	1,465.	1,559.	1,668.	2,088.
		78"	1 1/2"	RATDCFM(L/R)7836( ) ( ) ( )	1,488.	1,583.	1,701.	2,152.
		84"	1 1/2"	RATDCFM(L/R)8436( ) ( ) ( )	1,511.	1,607.	1,732.	2,214.
 <p>Left hand shown</p>	30"	48"	1 1/2"	RSTDCFM(L/R)4830( ) ( ) ( )	1,547.	1,646.	1,712.	1,971.
		54"	1 1/2"	RSTDCFM(L/R)5430( ) ( ) ( )	1,566.	1,666.	1,739.	2,024.
		60"	1 1/2"	RSTDCFM(L/R)6030( ) ( ) ( )	1,617.	1,720.	1,800.	2,112.
		66"	1 1/2"	RSTDCFM(L/R)6630( ) ( ) ( )	1,636.	1,740.	1,826.	2,166.
		72"	1 1/2"	RSTDCFM(L/R)7230( ) ( ) ( )	1,662.	1,768.	1,862.	2,228.
		78"	1 1/2"	RSTDCFM(L/R)7830( ) ( ) ( )	1,682.	1,789.	1,889.	2,282.
		84"	1 1/2"	RSTDCFM(L/R)8430( ) ( ) ( )	1,708.	1,817.	1,924.	2,343.
	36"	48"	1 1/2"	RSTDCFM(L/R)4836( ) ( ) ( )	1,582.	1,683.	1,760.	2,057.
		54"	1 1/2"	RSTDCFM(L/R)5436( ) ( ) ( )	1,606.	1,708.	1,793.	2,121.
		60"	1 1/2"	RSTDCFM(L/R)6036( ) ( ) ( )	1,658.	1,764.	1,857.	2,215.
		66"	1 1/2"	RSTDCFM(L/R)6636( ) ( ) ( )	1,682.	1,789.	1,890.	2,279.
		72"	1 1/2"	RSTDCFM(L/R)7236( ) ( ) ( )	1,711.	1,820.	1,929.	2,348.
		78"	1 1/2"	RSTDCFM(L/R)7836( ) ( ) ( )	1,733.	1,844.	1,961.	2,412.
		84"	1 1/2"	RSTDCFM(L/R)8436( ) ( ) ( )	1,756.	1,868.	1,993.	2,474.

Worksurfaces

Order Code	Specification Information	Application Notes
Example: <b>RATDCFM (L/R)4830</b>	<i>To order please specify pattern number including:</i>	Modesty sold separately and can be field installed.
<b>R</b> Reff	1. Grommet option: E=End grommet N=No grommet	Wire chase sold separately.
<b>AT</b> Asymmetrical Top	2. Grommet finish: Painted or Plated	Worksurface stiffeners, recommended to provide additional support for open spans greater than 48" w.
<b>D</b> 1 1/2"	3. Top finish: L, V1, V2, V3	Refer to grommet page for location option.
<b>C</b> Column Leg	4. Leg finish: Painted or Plated	From users perspective, if the leg is on the right side, the peninsula is classified a "Right Hand" peninsula.
<b>FM</b> Flush Mount Plate		
<b>L/R</b> Left/Right Hand		
<b>48</b> Width		
<b>30</b> Depth		
<b>N</b> Grommet Option		
<b>115</b> Grommet Finish		
<b>V316</b> Worksurface Finish		
<b>115</b> Leg Finish		

Peninsula 1 1/2"  
 Worksurface with Column Leg  
 Flush Mount Attachment, P and 9 tops

description	d	w	th	pattern no.	L	M/V1	V2	V3
Peninsula, P Shaped Top	30"	84"	1 1/2"	<b>RPTDCFM8430</b> ( ) ( ) ( )	\$1,967.	\$2,114.	\$2,392.	\$3,137.
	30"	96"	1 1/2"	<b>RPTDCFM9630</b> ( ) ( ) ( )	2,037.	2,195.	2,480.	3,254.

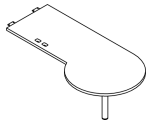

Peninsula, 9 Shaped Top	30"	84"	1 1/2"	<b>R9TDCFM8430</b> ( ) ( ) ( )	1,967.	2,114.	2,392.	3,137.
	30"	96"	1 1/2"	<b>R9TDCFM9630</b> ( ) ( ) ( )	2,037.	2,195.	2,480.	3,254.

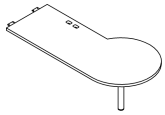

Order Code	Specification Information	Application Notes
Example: <b>RPTDCFM8430</b> ( ) ( ) ( )	<i>To order please specify pattern number including:</i>	Modesty sold separately and can be field installed.
<b>R</b> Reff	1. Grommet option: F=Flush	Wire chase sold separately.
<b>PT</b> P-Shaped top	M=Mid. Grommet	Worksurface stiffeners, recommended to provide additional support for open spans greater than 48"w.
<b>D</b> 1 1/2"	N=No grommet	Refer to grommet page for location option.
<b>C</b> Column Leg	2. Grommet finish: Painted or Plated	From users perspective, if the leg is on the right side, the peninsula is classified a "Right Hand" peninsula.
<b>FM</b> Flush Mount Attachment Plate	3. Top finish: L, V1, V2, V3	
<b>84</b> Width	4. Leg finish: Painted or Plated	
<b>30</b> Depth		
<b>N</b> Grommet Option		
<b>115</b> Grommet Finish		
<b>114</b> Worksurface Finish		
<b>115</b> Leg Finish		

Peninsula 1 1/2"  
 Worksurface with Column Leg  
 Stand-Off with Power Center, D top

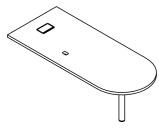
description	d	w	th	pattern no.	L	M/V1	V2	V3
 <p>Left hand shown</p>	30"	66"	1 1/2"	RDTDCPC(L/R)6630( ) ( ) ( ) ( )	\$1,639.	\$1,821.	\$1,901.	\$2,216.
		72"	1 1/2"	RDTDCPC(L/R)7230( ) ( ) ( ) ( )	1,662.	1,847.	1,934.	2,274.
		78"	1 1/2"	RDTDCPC(L/R)7830( ) ( ) ( ) ( )	1,680.	1,867.	1,960.	2,325.
		84"	1 1/2"	RDTDCPC(L/R)8430( ) ( ) ( ) ( )	1,703.	1,892.	1,991.	2,382.
		90"	1 1/2"	RDTDCPC(L/R)9030( ) ( ) ( ) ( )	1,721.	1,912.	2,017.	2,432.
		96"	1 1/2"	RDTDCPC(L/R)9630( ) ( ) ( ) ( )	1,737.	1,930.	2,041.	2,480.
	36"	66"	1 1/2"	RDTDCPC(L/R)6636( ) ( ) ( ) ( )	1,679.	1,866.	1,960.	2,322.
		72"	1 1/2"	RDTDCPC(L/R)7236( ) ( ) ( ) ( )	1,706.	1,895.	1,996.	2,386.
		78"	1 1/2"	RDTDCPC(L/R)7836( ) ( ) ( ) ( )	1,725.	1,917.	2,026.	2,446.
		84"	1 1/2"	RDTDCPC(L/R)8436( ) ( ) ( ) ( )	1,745.	1,939.	2,056.	2,503.
		90"	1 1/2"	RDTDCPC(L/R)9036( ) ( ) ( ) ( )	1,766.	1,962.	2,086.	2,561.
		96"	1 1/2"	RDTDCPC(L/R)9636( ) ( ) ( ) ( )	1,787.	1,985.	2,116.	2,620.

Worksurfaces

Order Code	Specification Information	Application Notes
Example: <b>RDTDCPCL6630</b> ( ) ( ) ( )	<i>To order please specify pattern number including:</i>	Modesty sold separately and can be field installed.
<b>R</b> Reff	1. Grommet option: P=Power center PM=Power center and middle grommet	Wire chase sold separately.
<b>DT</b> P-Shaped top	2. Grommet finish: Painted or Plated	Worksurface stiffeners, recommended to provide additional support for open spans greater than 48" w.
<b>D</b> 1 1/2"	3. Top finish: L, V1, V2, V3	Refer to grommet page for location option.
<b>C</b> Column Leg	4. Leg finish: Painted or Plated	From users perspective, if the leg is on the right side, the peninsula is classified a "Right Hand" peninsula.
<b>PC</b> Power Center	5. Stand-off finish: Painted	
<b>L</b>		
<b>66</b> Width		
<b>30</b> Depth		
<b>P</b> Grommet option		
<b>115</b> Grommet finish		
<b>V316</b> Top finish		
<b>115</b> Leg Finish		
<b>115</b> Stand-Off Finish		

Peninsula 1 1/2"  
 Worksurface with Column Leg  
 Stand-Off, D top

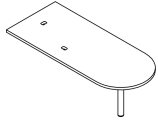
description	d	w	th	pattern no.	L	M/V1	V2	V3
 Peninsula, D-Shaped Top  <i>Left hand shown</i>	30"	66"	1 1/2"	RDTDCST(L/R)6630( ) ( ) ( ) ( )	\$1,499.	\$1,665.	\$1,745.	\$2,060.
		72"	1 1/2"	RDTDCST(L/R)7230( ) ( ) ( ) ( )	1,522.	1,691.	1,778.	2,118.
		78"	1 1/2"	RDTDCST(L/R)7830( ) ( ) ( ) ( )	1,540.	1,711.	1,804.	2,169.
		84"	1 1/2"	RDTDCST(L/R)8430( ) ( ) ( ) ( )	1,562.	1,736.	1,835.	2,226.
		90"	1 1/2"	RDTDCST(L/R)9030( ) ( ) ( ) ( )	1,580.	1,756.	1,861.	2,276.
		96"	1 1/2"	RDTDCST(L/R)9630( ) ( ) ( ) ( )	1,597.	1,774.	1,885.	2,324.
	36"	66"	1 1/2"	RDTDCST(L/R)6636( ) ( ) ( ) ( )	1,539.	1,710.	1,804.	2,166.
		72"	1 1/2"	RDTDCST(L/R)7236( ) ( ) ( ) ( )	1,565.	1,739.	1,840.	2,230.
		78"	1 1/2"	RDTDCST(L/R)7836( ) ( ) ( ) ( )	1,585.	1,761.	1,870.	2,290.
		84"	1 1/2"	RDTDCST(L/R)8436( ) ( ) ( ) ( )	1,605.	1,783.	1,900.	2,347.
		90"	1 1/2"	RDTDCST(L/R)9036( ) ( ) ( ) ( )	1,625.	1,806.	1,930.	2,405.
		96"	1 1/2"	RDTDCST(L/R)9636( ) ( ) ( ) ( )	1,646.	1,829.	1,960.	2,464.

Order Code	Specification Information	Application Notes
Example: <b>RDTDCST6630 ( ) ( ) ( )</b>	<i>To order please specify pattern number including:</i>	Modesty sold separately and can be field installed.
<b>R</b> Reff		Peninsula worksurfaces with power center do not come with Electrical Components.
<b>DT</b> D-Shaped top	1. Grommet option: S=Stand-off SM=Stand-off plus grommet	Wire chase sold separately.
<b>D</b> 1 1/2"	M=Mid. Grommet N=No grommet	Worksurface stiffeners, recommended to provide additional support for open spans greater than 48" w.
<b>C</b> Column Leg	2. Grommet finish: Painted or Plated	Refer to grommet page for location option.
<b>ST</b> Stand-Off	3. Top finish: L, V1, V2, V3	From users perspective, if the leg is on the right side, the peninsula is classified a "Right Hand" peninsula.
<b>66</b> Width	4. Leg finish: Painted or Plated	
<b>30</b> Depth	5. Stand-off finish: Painted	
<b>N</b> Grommet Option		
<b>115</b> Grommet Finish		
<b>V316</b> Worksurface Finish		
<b>115</b> Leg Finish		
<b>115</b> Stand-Off Finish		

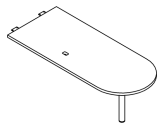

Peninsula 1 1/2"  
 Worksurface with Column Leg  
 Flush Mount Attachment, D top

description	d	w	th	pattern no.	L	M/V1	V2	V3
 <p>Left hand shown</p>	30"	54"	1 1/2"	RDTDCFM(L/R)5430( ) ( ) ( )	\$1,329.	\$1,477.	\$1,545.	\$1,810.
		60"	1 1/2"	RDTDCFM(L/R)6030( ) ( ) ( )	1,382.	1,535.	1,609.	1,900.
		66"	1 1/2"	RDTDCFM(L/R)6630( ) ( ) ( )	1,399.	1,554.	1,634.	1,950.
		72"	1 1/2"	RDTDCFM(L/R)7230( ) ( ) ( )	1,422.	1,580.	1,667.	2,007.
		78"	1 1/2"	RDTDCFM(L/R)7830( ) ( ) ( )	1,440.	1,600.	1,693.	2,058.
		84"	1 1/2"	RDTDCFM(L/R)8430( ) ( ) ( )	1,463.	1,625.	1,725.	2,115.
	36"	54"	1 1/2"	RDTDCFM(L/R)5436( ) ( ) ( )	1,364.	1,516.	1,595.	1,900.
		60"	1 1/2"	RDTDCFM(L/R)6036( ) ( ) ( )	1,419.	1,577.	1,663.	1,996.
		66"	1 1/2"	RDTDCFM(L/R)6636( ) ( ) ( )	1,439.	1,599.	1,693.	2,055.
		72"	1 1/2"	RDTDCFM(L/R)7236( ) ( ) ( )	1,465.	1,628.	1,729.	2,119.
		78"	1 1/2"	RDTDCFM(L/R)7836( ) ( ) ( )	1,486.	1,651.	1,760.	2,179.
		84"	1 1/2"	RDTDCFM(L/R)8436( ) ( ) ( )	1,506.	1,673.	1,789.	2,236.

Worksurfaces

Order Code	Specification Information	Application Notes
Example: <b>RDTDCFM5430</b> ( ) ( ) ( )	<i>To order please specify pattern number including:</i>	Modesty sold separately and can be field installed.
<b>R</b> Reff	1. Grommet option: N=None M=Middle	Wire chase sold separately.
<b>DT</b> P-Shapped top	2. Grommet finish: Painted or Plated	Worksurface stiffeners, recommended to provide additional support for open spans greater than 48"w.
<b>D</b> 1 1/2"	3. Worksurface finish: L, V1, V2, V3	Refer to grommet page for location option.
<b>C</b> Column Leg	4. Leg finish: Painted or Plated	From users perspective, if the leg is on the right side, the peninsula is classified a "Right Hand" peninsula.
<b>FM</b> Flush Mount Attachment Plate		Peninsula worksurfaces with power center do not come with Electrical Components.
<b>54</b> Width		For electrical components please refer to page 424.
<b>30</b> Depth		
<b>M</b> Grommet Option		
<b>115</b> Grommet Finish		
<b>V316</b> Worksurface Finish		
<b>115</b> Leg Finish		

Tables, 1 1/2"  
 Rectangle with L-Leg  
 30" and 36" deep

description	d	w	th	pattern no.	L	M/V1	V2	V3
Table Top Rectangle 30" Deep with 26 1/2" height leg	30"	48"	1 1/2"	<b>RTRDL48301</b> ( ) ( )	\$1,381.	\$1,469.	\$1,535.	\$1,794.
	30"	60"	1 1/2"	<b>RTRDL60301</b> ( ) ( )	1,451.	1,544.	1,623.	1,936.
	30"	72"	1 1/2"	<b>RTRDL72301</b> ( ) ( )	1,496.	1,592.	1,686.	2,051.

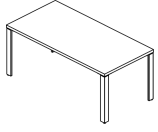

Table Top Rectangle 36" Deep with 26 1/2" height leg	36"	72"	1 1/2"	<b>RTRDL72361</b> ( ) ( )	1,544.	1,643.	1,752.	2,172.
---------------------------------------------------------	-----	-----	--------	---------------------------	--------	--------	--------	--------

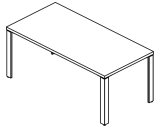

Table Top Rectangle 30" Deep with 28 3/8" height leg	30"	48"	1 1/2"	<b>RTRDL48302</b> ( ) ( )	1,441.	1,529.	1,595.	1,854.
	30"	60"	1 1/2"	<b>RTRDL60302</b> ( ) ( )	1,511.	1,604.	1,683.	1,996.
	30"	72"	1 1/2"	<b>RTRDL72302</b> ( ) ( )	1,556.	1,652.	1,746.	2,111.

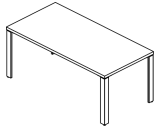
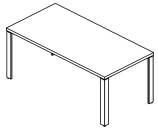

Table Top Rectangle 36" Deep with 28 3/8" height leg	36"	72"	1 1/2"	<b>RTRDL72362</b> ( ) ( )	1,604.	1,703.	1,812.	2,232.
---------------------------------------------------------	-----	-----	--------	---------------------------	--------	--------	--------	--------



Order Code	
Example: <b>RTRDL48301</b> ( ) ( )	
<b>R</b>	Reff
<b>TR</b>	Table Rectangular
<b>D</b>	1 1/2"
<b>L</b>	L-Leg
<b>48</b>	Width
<b>30</b>	Depth
<b>1</b>	26 1/2" height leg
<b>V316</b>	Finish
<b>111</b>	Leg Finish

**Specification Information**

*To order please specify pattern number including:*

1. Worksurface finish  
L, V1, V2, V3
2. Leg finish  
Painted / Anodized

**Application Notes**

Assembly required, ships knock down.

Modesty sold separately.

Worksurface stiffeners, recommended to provide additional support for open spans greater than 48"w.

Grommets are NOT optional for these tables.

Tables, 1 1/2"  
 Rectangle with Reverse L-Leg  
 30" and 36" deep

description	d	w	th	pattern no.	L	M/V1	V2	V3
Table Top Rectangle 30" Deep with 26 1/2" height leg	30"	48"	1 1/2"	<b>RTRDRL48301</b> ( ) ( ) ( )	\$1,381.	\$1,469.	\$1,535.	\$1,794.
	30"	60"	1 1/2"	<b>RTRDRL60301</b> ( ) ( ) ( )	1,451.	1,544.	1,623.	1,936.
	30"	72"	1 1/2"	<b>RTRDRL72301</b> ( ) ( ) ( )	1,496.	1,592.	1,685.	2,051.

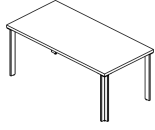

Table Top Rectangle 36" Deep with 26 1/2" height leg	36"	72"	1 1/2"	<b>RTRDRL72361</b> ( ) ( ) ( )	1,544.	1,643.	1,752.	2,172.
---------------------------------------------------------	-----	-----	--------	--------------------------------	--------	--------	--------	--------

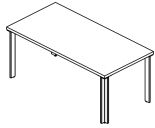

Table Top Rectangle 30" Deep with 28 3/8" height leg	30"	48"	1 1/2"	<b>RTRDRL48302</b> ( ) ( ) ( )	1,441.	1,529.	1,595.	1,854.
	30"	60"	1 1/2"	<b>RTRDRL60302</b> ( ) ( ) ( )	1,511.	1,604.	1,683.	1,996.
	30"	72"	1 1/2"	<b>RTRDRL72302</b> ( ) ( ) ( )	1,556.	1,652.	1,745.	2,111.

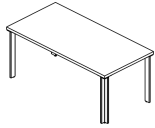
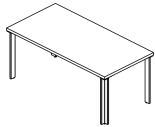

Table Top Rectangle 36" Deep with 28 3/8" height leg	36"	72"	1 1/2"	<b>RTRDRL72362</b> ( ) ( ) ( )	1,604.	1,703.	1,812.	2,232.
---------------------------------------------------------	-----	-----	--------	--------------------------------	--------	--------	--------	--------



Order Code	Specification Information	Application Notes
Example: <b>RTRDRL48301</b> ( ) ( ) ( )	To order please specify pattern number including:	Assembly required, ships knock down.
<b>R</b> Reff		Modesty sold separately.
<b>TR</b> Table Rectangular	1. Worksurface finish	Worksurface stiffeners, recommended to provide additional support for open spans greater than 48"w.
<b>D</b> 1 1/2"	L, V1, V2, V3	Grommets are NOT optional for these tables.
<b>RL</b> Reverse L-Leg	2. Leg finish	
<b>48</b> Width	Painted / Anodized	
<b>30</b> Depth		
<b>1</b> 26 1/2" height leg		
<b>V316</b> Finish		
<b>111</b> Leg Finish		

Tables, 1 1/2"  
 Rectangle with Soft Rectangular Leg  
 30" and 36" deep

description	depth	width	thickness	pattern number	L	M/V1	V2	V3
Table Top Rectangle 30" Deep with 26 1/2" height leg	30"	48"	1 1/2"	<b>RTRDS48301</b> ( ) ( ) ( )	\$1,277.	\$1,359.	\$1,425.	\$1,684.
	30"	60"	1 1/2"	<b>RTRDS60301</b> ( ) ( ) ( )	1,348.	1,434.	1,513.	1,826.
	30"	72"	1 1/2"	<b>RTRDS72301</b> ( ) ( ) ( )	1,393.	1,482.	1,575.	1,942.

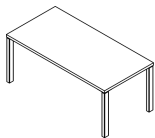

Table Top Rectangle 36" Deep with 26 1/2" height leg	36"	72"	1 1/2"	<b>RTRDS72361</b> ( ) ( ) ( )	1,441.	1,533.	1,642.	2,062.
---------------------------------------------------------	-----	-----	--------	-------------------------------	--------	--------	--------	--------

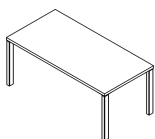

Table Top Rectangle 30" Deep with 28 3/8" height leg	30"	48"	1 1/2"	<b>RTRDS48302</b> ( ) ( ) ( )	1,337.	1,419.	1,485.	1,744.
	30"	60"	1 1/2"	<b>RTRDS60302</b> ( ) ( ) ( )	1,408.	1,494.	1,573.	1,886.
	30"	72"	1 1/2"	<b>RTRDS72302</b> ( ) ( ) ( )	1,453.	1,542.	1,635.	2,002.

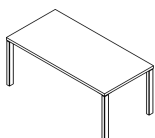
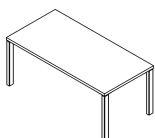

Table Top Rectangle 36" Deep with 28 3/8" height leg	36"	72"	1 1/2"	<b>RTRDS72362</b> ( ) ( ) ( )	1,501.	1,593.	1,702.	2,122.
---------------------------------------------------------	-----	-----	--------	-------------------------------	--------	--------	--------	--------



Order Code	
Example: <b>RTRDS48301</b> ( ) ( ) ( )	
<b>R</b>	Reff
<b>TR</b>	Table Rectangular
<b>D</b>	1 1/2"
<b>S</b>	Soft Rectangular Leg
<b>48</b>	Width
<b>30</b>	Depth
<b>1</b>	26 1/2" height leg
<b>V316</b>	Finish
<b>111</b>	Leg Finish

Specification Information
To order please specify pattern number including:
1. Worksurface finish L, V1, V2, V3
2. Leg finish Painted / Anodized

Application Notes
Assembly required, ships knock down.
Modesty sold separately.
Worksurface stiffeners, recommended to provide additional support for open spans greater than 48"w.
Grommets are NOT optional for these tables.

Tables, 1 1/2"  
 Square with L-Leg  
 42" and 48" deep

description	w	d	th	pattern no.	L	V1	V2	V3
Table Square with 26 1/2" height legs	42"	42"	1 1/2"	RTSDL42421( ) ( ) ( )	\$1,419.	\$1,510.	\$1,588.	\$1,890.
	48"	48"	1 1/2"	RTSDL48481( ) ( ) ( )	1,481.	1,576.	1,675.	2,050.

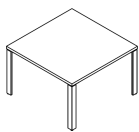
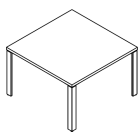

Table Top Square with 28 3/8" height legs	42"	42"	1 1/2"	RTSDL42422( ) ( ) ( )	1,476.	1,570.	1,648.	1,950.
	48"	48"	1 1/2"	RTSDL48482( ) ( ) ( )	1,538.	1,636.	1,735.	2,110.



Worksurfaces

Order Code	
Example: <b>RTSDL42421</b> ( ) ( ) ( )	
<b>R</b>	Reff
<b>TS</b>	Table Square
<b>D</b>	1 1/2"
<b>L</b>	L-Leg
<b>42</b>	Width
<b>42</b>	Depth
<b>1</b>	26 1/2" height leg
<b>V316</b>	Finish
<b>111</b>	Leg Finish

Specification Information
To order please specify pattern number including:
1. Worksurface finish L, V1, V2, V3
2. Leg finish Painted / Anodized

Application Notes
Assembly required, ships knock down.
Modesty sold separately.
Grommets are NOT optional for these tables.

Tables, 1 1/2"  
 Square with Reverse L-Leg  
 42" and 48" deep

description	th	d	w	pattern no.	L	V1	V2	V3
Table Top Square with 26 1/2" height legs	1 1/2"	42"	42"	RTSDRL42421()()()	\$1,419.	\$1,510.	\$1,588.	\$1,890.
	1 1/2"	48"	48"	RTSDRL48481()()()	1,481.	1,576.	1,675.	2,050.

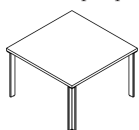
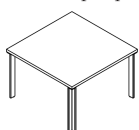

Table Top Square with 28 3/8" height legs	1 1/2"	42"	42"	RTSDRL42422()()()	1,476.	1,570.	1,648.	1,950.
	1 1/2"	48"	48"	RTSDRL48482()()()	1,538.	1,636.	1,735.	2,110.



Order Code	
Example: <b>RTSDRL42421</b> ()()()	
<b>R</b>	Reff
<b>TS</b>	Table Square
<b>D</b>	1 1/2"
<b>RL</b>	Reverse L-Leg
<b>42</b>	Width
<b>42</b>	Depth
<b>1</b>	26 1/2" height leg
<b>V316</b>	Finish
<b>111</b>	Leg Finish

Specification Information
To order please specify pattern number including:
1. Worksurface finish L, V1, V2, V3
2. Leg finish Painted / Anodized

Application Notes
Assembly required, ships knock down.
Modesty sold separately.
Grommets are NOT optional for these tables.

Tables, 1 1/2"  
 Square with Soft Rectangular Leg  
 42" and 48" deep

description	th	d	w	pattern no.	L	V1	V2	V3
Table Square with 26 1/2" height legs	1 1/2"	42"	42"	<b>RTSDS42421</b> ( ) ( ) ( )	\$1,456.	\$1,549.	\$1,627.	\$1,928.
	1 1/2"	48"	48"	<b>RTSDS48481</b> ( ) ( ) ( )	1,518.	1,615.	1,713.	2,089.

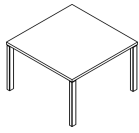

description	th	d	w	pattern no.	L	V1	V2	V3
Table Top Square with 28 3/8" height legs	1 1/2"	42"	42"	<b>RTSDS42422</b> ( ) ( ) ( )	1,512.	1,609.	1,687.	1,988.
	1 1/2"	48"	48"	<b>RTSDS48482</b> ( ) ( ) ( )	1,575.	1,675.	1,773.	2,149.

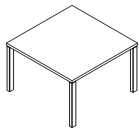



Order Code	
Example:	<b>RTSDS42421</b> ( ) ( ) ( )
<b>R</b>	Reff
<b>TS</b>	Table Square
<b>D</b>	1 1/2"
<b>S</b>	Soft Rectangular-Leg
<b>42</b>	Width
<b>42</b>	Depth
<b>1</b>	26 1/2" height leg
<b>V316</b>	Finish
<b>111</b>	Leg Finish

Specification Information
To order please specify pattern number including:
1. Worksurface finish L, V1, V2, V3
2. Leg finish Painted / Anodized

Application Notes
Assembly required, ships knock down.
Modesty sold separately.
Grommets are NOT optional for these tables.

Tables, 1 1/2"  
 Round with Column Leg  
 36", 42" and 48" diameter

description	th	dia.	pattern no.	L	V1	V2	V3
 Table Top Round with 26 1/2" height legs	1 1/2"	36"	<b>RTNDC361</b> ( ) ( ) ( )	\$2,369.	\$2,520.	\$2,579.	\$2,791.
	1 1/2"	42"	<b>RTNDC421</b> ( ) ( ) ( )	2,429.	2,584.	2,661.	2,934.
	1 1/2"	48"	<b>RTNDC481</b> ( ) ( ) ( )	2,489.	2,648.	2,745.	3,088.

 Table Top Round with 28 3/8" height legs	1 1/2"	36"	<b>RTNDC422</b> ( ) ( ) ( )	2,425.	2,580.	2,639.	2,851.
	1 1/2"	42"	<b>RTNDC362</b> ( ) ( ) ( )	2,485.	2,644.	2,721.	2,994.
	1 1/2"	48"	<b>RTNDC482</b> ( ) ( ) ( )	2,546.	2,708.	2,805.	3,148.

Order Code	
Example:	<b>RTNDC361</b> ( ) ( ) ( )
<b>R</b>	Reff
<b>TN</b>	Table Round
<b>D</b>	1 1/2"
<b>C</b>	Column Leg
<b>36</b>	Diameter
<b>1</b>	26 1/2" height leg
<b>V316</b>	Finish
<b>111</b>	Leg Finish

**Specification Information**

*To order please specify pattern number including:*

1. Worksurface finish  
L, V1, V2, V3
2. Leg finish  
Painted / Plated

**Application Notes**

Assembly required, ships knock down.

Modesty sold separately.







Grommets are NOT optional for these tables.



# Tables, 1" Laminate

Reff Profiles

Worksurfaces

description	d	w	th	pattern no.	L
Round Table with 26 1/2" height legs 	36"		1"	<b>RSTRLE361</b> ( ) ( )	\$2,918.
	42"		1"	<b>RSTRLE421</b> ( ) ( )	2,976.
Round Table with 28 3/8" height legs 	36"		1"	<b>RSTRLE362</b> ( ) ( )	2,974.
	42"		1"	<b>RSTRLE422</b> ( ) ( )	3,032.
Soft Square Table with 26 1/2" height legs 	36"		1"	<b>RSTSLE361</b> ( ) ( )	2,892.
	42"		1"	<b>RSTSLE421</b> ( ) ( )	2,954.
Soft Square Table with 28 3/8" height legs 	36"		1"	<b>RSTSLE362</b> ( ) ( )	2,949.
	42"		1"	<b>RSTSLE422</b> ( ) ( )	3,011.
Soft Rectangle Table with 26 1/2" height legs 	30"	48"	1"	<b>RSTTLE30481</b> ( ) ( )	2,725.
	36"	54"	1"	<b>RSTTLE36541</b> ( ) ( )	2,797.
Soft Rectangle Table with 28 3/8" height legs 	30"	48"	1"	<b>RSTTLE30482</b> ( ) ( )	2,781.
	36"	54"	1"	<b>RSTTLE36542</b> ( ) ( )	2,853.

## Order Code

Example: <b>RSTRLE361</b> ( ) ( )
<b>R</b> Reff
<b>ST</b> Slider Table
<b>R</b> Round
<b>L</b> Laminate surface
<b>E</b> 1" thick
<b>42</b> 42" diameter
<b>1</b> 26 1/2" height leg
<b>114</b> Finish
<b>118T</b> Leg Finish

## Specification Information

To order please specify pattern number including:







1. Worksurface finish:  
Laminate only
2. Leg Textured finish:  
111T, 115T, 118T

## Application Notes

Assembly required.  
Ships knocked down.  
Grommets are not an option for these tables.  
Column and base are color matched  
Column = smooth  
Base = textured

# Tables, 1" Wood

Reff Profiles







description	d	w	th	pattern no.	V1	V2	V3
Round Table with 26 1/2" height legs 	36"		1"	<b>RSTRWE361</b> ( ) ( )	\$3,104.	\$3,152.	\$3,396.
	42"		1"	<b>RSTRWE421</b> ( ) ( )	3,166.	3,230.	3,533.
Round Table with 28 3/8" height legs 	36"		1"	<b>RSTRWE362</b> ( ) ( )	3,164.	3,212.	3,456.
	42"		1"	<b>RSTRWE422</b> ( ) ( )	3,226.	3,290.	3,593.
Soft Square Table with 26 1/2" height legs 	36"		1"	<b>RSTSWE361</b> ( ) ( )	3,077.	3,125.	3,390.
	42"		1"	<b>RSTSWE421</b> ( ) ( )	3,143.	3,206.	3,533.
Soft Square Table with 28 3/8" height legs 	36"		1"	<b>RSTSWE362</b> ( ) ( )	3,137.	3,185.	3,450.
	42"		1"	<b>RSTSWE422</b> ( ) ( )	3,203.	3,266.	3,593.
Soft Rectangle Table with 26 1/2" height legs 	30"	48"	1"	<b>RSTTWE30481</b> ( ) ( )	2,899.	2,951.	3,238.
	36"	54"	1"	<b>RSTTWE36541</b> ( ) ( )	2,975.	3,044.	3,397.
Soft Rectangle Table with 28 3/8" height legs 	30"	48"	1"	<b>RSTTWE30482</b> ( ) ( )	2,959.	3,011.	3,298.
	36"	54"	1"	<b>RSTTWE36542</b> ( ) ( )	3,035.	3,104.	3,457.

Order Code	Specification Information	Application Notes
Example: <b>RSTRWE361</b> ( ) ( )	To order please specify pattern number including:	Column and base are color matched.
<b>R</b> Reff	1. Worksurface finish	Column=smooth
<b>ST</b> Slider Table	V1, V2, V3 wood only	Base=textured
<b>R</b> Round	2. Leg Textured finish:	Assembly required, ships knock down.
<b>W</b> Wood surface	111T, 115T, 118T	Grommets are not an option for these tables.
<b>E</b> 1" thick		
<b>42</b> 42" diameter		
<b>1</b> 26 1/2" height leg		
<b>V316</b> Finish		
<b>111T</b> Leg Finish		

# Tables, 1" Solid

Reff Profiles

Worksurfaces

description	d	w	th	pattern no.	Solid
Round Table with 26 1/2" height legs 	36"		1"	<b>RSTRSE361</b> ( ) ( )	\$7,959.
	42"		1"	<b>RSTRSE421</b> ( ) ( )	9,119.
Round Table with 28 3/8" height legs 	36"		1"	<b>RSTRSE362</b> ( ) ( )	7,959.
	42"		1"	<b>RSTRSE422</b> ( ) ( )	9,119.
Soft Square Table with 26 1/2" height legs 	36"		1"	<b>RSTSSE361</b> ( ) ( )	7,116.
	42"		1"	<b>RSTSSE421</b> ( ) ( )	8,393.
Soft Square Table with 28 3/8" height legs 	36"		1"	<b>RSTSSE362</b> ( ) ( )	7,116.
	36"		1"	<b>RSTSSE362</b> ( ) ( )	7,116.
Soft Rectangle Table with 26 1/2" height legs 	30"	48"	1"	<b>RSTTSE30481</b> ( ) ( )	8,769.
	36"	54"	1"	<b>RSTTSE36541</b> ( ) ( )	9,724.
Soft Rectangle Table with 28 3/8" height legs 	30"	48"	1"	<b>RSTTSE30482</b> ( ) ( )	8,769.
	36"	54"	1"	<b>RSTTSE36542</b> ( ) ( )	9,724.

## Order Code

Example:	<b>RSTRSE361</b> ( ) ( )
<b>R</b>	Reff
<b>ST</b>	Slider Table
<b>R</b>	Round
<b>S</b>	Solid
<b>E</b>	1" thick
<b>42</b>	42" diameter
<b>1</b>	26 1/2" height leg
<b>AW</b>	Worksurface finish
<b>111T</b>	Leg Finish

## Specification Information

To order please specify pattern number including:  
 1. Worksurface finish:  
     AW=Artic White, only  
 2. Leg finish Textured:  
     111T, 115T, 118T

## Application Notes

Assembly required.  
 Ships knocked down.  
 Grommets are not an option for these tables.  
 Artic White finish available for solid tops.  
 Column and base are color matched.  
 Column=smooth  
 Base=textured

# Top support components

## Bracketry

description	d	pattern no.	P1& black only	P2	P3
Cantilever bracket, panel hung	18"	<b>RBC18 (L/R)</b>	\$90.	\$94.	\$98.
	24"	<b>RBC24 (L/R)</b>	98.	104.	110.

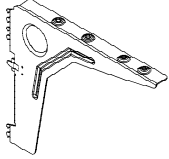

Specify paint finish  
 18" for 20" and 24"d tops  
 24" for 30" and 36"d tops  
 Ships with machine screws for fastening to underside of worksurfaces with metal inserts

Cantilever bracket, panel hung for cascade edge worksurface	18"	<b>ASBC18 (L/R) ( )</b>	90.	95.	99.
	24"	<b>ASBC24 (L/R) ( )</b>	99.	107.	112.

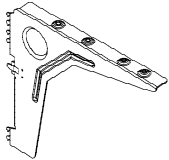

Specify paint finish  
 18" for 24"d tops  
 24" for 30" d tops  
 Ships with wood screws (use with AutoStrada, Dividends Horizon, Morrison and Cascade worksurfaces)

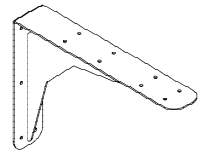

Mid-span cantilever bracket, free standing	17"	<b>RMSCB ( )</b>	72.	77.	81.
--------------------------------------------	-----	------------------	-----	-----	-----



Order Code	Specification Information	Application Notes
Example: <b>RBC18L</b>	<i>To order please specify pattern number including:</i>	For wood tops black bracketry is recommended.
<b>R</b> Reff	1. Left or right-hand, where applicable.	Refer to page 422 for replacement hardware.
<b>B</b> Bracket	2. Top thickness, where applicable.	Utility bracket for use in securing free end of modesty on D and P tops when a return panel is not used or for T-bases in off module application.
<b>C</b> Cantilever	3. Finish type	Cantilever should be specified with top to top brackets.
<b>18</b> 18" deep	4. Finish, where applicable	Cantilevers can be used for corner worksurfaces or to join two adjacent straight worksurfaces together.
<b>L</b> Left hand	2. <i>Top thickness option:</i> A = 1 1/4" thick B = 1 3/4" thick	<b>Knoll takes no responsibility for the installation or security of tops to the wall.</b>
L brackets may be used in off module applications for L bases, T bases and half depth end panels.	When planning with Reff overheads half depth and panel may be required for additional support. Refer to pages 32 and 33 in the Planning Guide.	

# Top support components

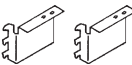

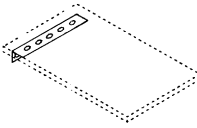
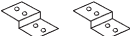
## Bracketry

description	d	pattern no.	P1& black only	P2	P3
Corner top corner bracket 		<b>RBCC</b>	\$18.		
	Black only				
Side hung support bracket 		<b>RBCCP (Pair)</b>	39.	41.	42.
	Specify paint finish pair includes one each left and right hand bracket image depicts two left hand brackets				
Panel to pedestal bracket		<b>RBPP (L/R)</b>	8.		
	Black only				
Top to top bracket 	6" x 1"	<b>RBF (Pair)</b>	5.		
	Black only				
Wall hung support bracket 	20" 24" 30" 36" 42" 48"	<b>RSBWH20</b> <b>RSBWH24</b> <b>RSBWH30</b> <b>RSBWH36</b> <b>RSBWH42</b> <b>RSBWH48</b>	41. 43. 47. 51. 54. 66.	43. 47. 49. 54. 57. 69.	45. 49. 51. 57. 60. 72.
	Specify paint finish				
Z-bracket for bridge applications 		<b>RBZ (A/B) (Pair)</b>	34.		
	Black only				

Order Code	Specification Information	Application Notes
Example: <b>RBC18L</b>	<i>To order please specify pattern number including:</i>	For wood tops black bracketry is recommended.
<b>R</b> Reff	1. Left or right-hand, where applicable.	Refer to page 422 for replacement hardware.
<b>B</b> Bracket	2. Top thickness, where applicable.	Utility bracket for use in securing free end of modesty on D and P tops when a return panel is not used or for T-bases in off module application.
<b>C</b> Cantilever	3. Finish type	Cantilever should be specified with top to top brackets.
<b>18</b> 18" deep	4. Finish, where applicable	Cantilevers can be used for corner worksurfaces or to join two adjacent straight worksurfaces together.
<b>L</b> Left hand	2. <i>Top thickness option:</i> A = 1 1/4" thick B = 1 3/4" thick	<b>Knoll takes no responsibility for the installation or security of tops to the wall.</b>
L brackets may be used in off module applications for L bases, T bases and half depth end panels.	When planning with Reff overheads half depth and panel may be required for additional support. Refer to pages 32 and 33 in the Planning Guide.	

# Top support components

## Bracketry

description	d	pattern no.	P1& black only	P2	P3
Modesty panel offset bracket Required to join modesty panel to end panel of adjacent top assembly - order separately.		<b>RBPR (Pair)</b>	\$7.	\$7.	\$8.
		Specify paint finish			
					
Panel to storage tower bracket Used to attach office tower to panels.		<b>RBPS (L/R)</b>	11.	13.	13.
		Specify paint finish			
Utility bracket		<b>RUTB</b>	11.		
		Black only			
L Bracket for off-module applications		<b>R113B</b>	5.		
		One by one by three bracket			
Worksurface to cabinet bracket for 24" worksurface		<b>RBWC24</b>	52.		
		bracket can be used with 20" and 24" worksurfaces			
Worksurface to cabinet bracket for 30" worksurface		<b>RBWC30</b>	57.		
		bracket can be used with 30" and 36" worksurfaces			

Order Code	Specification Information	Application Notes
Example: <b>RBC18L</b>	<i>To order please specify pattern number including:</i>	For wood tops black bracketry is recommended.
<b>R</b> Reff	1. Left or right-hand, where applicable.	Refer to page 422 for replacement hardware.
<b>B</b> Bracket	2. Top thickness, where applicable.	Utility bracket for use in securing free end of modesty on D and P tops when a return panel is not used or for T-bases in off module application.
<b>C</b> Cantilever	3. Finish type	Cantilever should be specified with top to top brackets.
<b>18</b> 18" deep	4. Finish, where applicable	Cantilevers can be used for corner worksurfaces or to join two adjacent straight worksurfaces together.
<b>L</b> Left hand	2. <i>Top thickness option:</i> A = 1 1/4" thick B = 1 3/4" thick	<b>Knoll takes no responsibility for the installation or security of tops to the wall.</b>
L brackets may be used in off module applications for L bases, T bases and half depth end panels.	When planning with Reff overheads half depth and panel may be required for additional support. Refer to pages 32 and 33 in the Planning Guide.	

Top support components  
26 1/2" high planning  
Modesty panels

description	d	w	h	pattern no.	L	V1	V2	V3
Modesty panels with hardware. <sup>15</sup> / <sub>16</sub> " actual thickness	24"	1"	26 1/2"	<b>RB24(M/H)(F/R)-()</b>	\$150.	\$213.	\$243.	\$329.
	30"	1"	26 1/2"	<b>RB30(M/H)(F/R)-()</b>	271.	380.	438.	591.
	36"	1"	26 1/2"	<b>RB36(M/H)(F/R)-()</b>	299.	417.	480.	647.
	42"	1"	26 1/2"	<b>RB42(M/H)(F/R)-()</b>	322.	453.	520.	703.
	48"	1"	26 1/2"	<b>RB48(M/H)(F/R)-()</b>	362.	510.	586.	791.
	54"	1"	26 1/2"	<b>RB54(M/H)(F/R)-()</b>	379.	535.	614.	829.
	60"	1"	26 1/2"	<b>RB60(M/H)(F/R)-()</b>	394.	551.	634.	854.
	66"	1"	26 1/2"	<b>RB66(M/H)(F/R)-()</b>	410.	575.	664.	898.
	72"	1"	26 1/2"	<b>RB72(M/H)(F/R)-()</b>	450.	634.	728.	984.
	78"	1"	26 1/2"	<b>RB78(M/H)(F/R)-()</b>	481.	674.	778.	1,051.
	84"	1"	26 1/2"	<b>RB84(M/H)(F/R)-()</b>	508.	716.	821.	1,109.
	90"	1"	26 1/2"	<b>RB90(M/H)(F/R)-()</b>	539.	758.	869.	1,174.
	96"	1"	26 1/2"	<b>RB96(M/H)(F/R)-()</b>	552.	776.	891.	1,202.

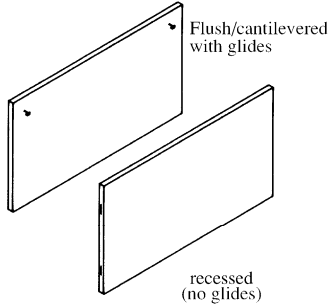

description	d	w	h	pattern no.	L	V1	V2	V3
Support for corner worksurfaces. All hardware included.	36"	36"	26 1/2"	<b>RB3636-()</b>	976.	1,448.	1,666.	2,250.
	36"	42"	26 1/2"	<b>RB3642-()</b>	998.	1,486.	1,710.	2,308.
	36"	48"	26 1/2"	<b>RB3648-()</b>	1,041.	1,543.	1,769.	2,389.
	42"	36"	26 1/2"	<b>RB4236-()</b>	998.	1,486.	1,710.	2,308.
	42"	42"	26 1/2"	<b>RB4242-()</b>	1,024.	1,522.	1,754.	2,368.
	42"	48"	26 1/2"	<b>RB4248-()</b>	1,064.	1,577.	1,815.	2,450.
	48"	36"	26 1/2"	<b>RB4836-()</b>	1,041.	1,543.	1,769.	2,389.
	48"	42"	26 1/2"	<b>RB4842-()</b>	1,064.	1,577.	1,815.	2,450.
	48"	48"	26 1/2"	<b>RB4848-()</b>	1,105.	1,635.	1,892.	2,554.

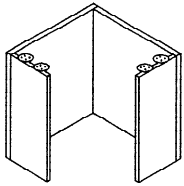

Support components

Order Code

Example:	<b>RB24MFL</b>
<b>R</b>	Reff
<b>B</b>	Back panel
<b>24</b>	48" panel dimension
<b>M</b>	Full height modesty
<b>F</b>	Flush modesty placement
<b>L</b>	Laminate
<b>114</b>	Folkstone grey

Specification Information

To order please specify pattern number including:

1. Modesty type
2. Modesty placement
3. Finish type
4. Finish

1. Modesty type:  
M = Standard height (26 1/2"H)  
H = Half height

2. Modesty placement:  
F = Flush, cantilevered  
R = Recessed

3. Finish type:  
L = Laminate  
1 = V1  
2 = V2  
3 = V3

Application Notes

Applicable finishes are listed on page 5 and 6.

Product on this page will accept woodgrain laminate where laminate is currently an option. List price for woodgrain laminate options will be current published laminate list price plus 10%.

Modesty panels and end panels come with all hardware necessary to attach to tops and each other to build freestanding desks. To join tops to tops or bridge assemblies to desk, hardware must be ordered.

Modesty support for corner worksurface includes end panels 12"D to support in free standing applications.

Modesty panel lengths are nominal - length changes on option selected.

Glides ship with all supports on this page except the recessed modesty panel.

Please see Planning Guide for freestanding planning instruction.

# Top support components

## 26 1/2" high planning

### End panels

description	d	w	h	pattern no.	L	V1	V2	V3
Endpanels for recessed modesty worksurfaces (sold in pairs). All hardware included.	30"	1"	26 1/2"	<b>RE30-( )</b>	\$462.	\$750.	\$864.	\$1,166.
	36"	1"	26 1/2"	<b>RE36-( )</b>	488.	786.	904.	1,220.

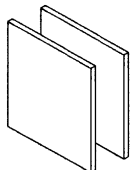

Panel end panels. All hardware included.	13"	1"	26 1/2"	<b>RSE1(L/R)-( )</b>	177.	306.	352.	476.
	16"	1"	26 1/2"	<b>RSE2(L/R)-( )</b>	190.	326.	375.	506.
	20"	1"	26 1/2"	<b>RSE3(L/R)-( )</b>	205.	343.	393.	530.
	24"	1"	26 1/2"	<b>RSE4(L/R)-( )</b>	216.	357.	413.	556.
	30"	1"	26 1/2"	<b>RSE5(L/R)-( )</b>	229.	377.	433.	586.
	36"	1"	26 1/2"	<b>RSE6(L/R)-( )</b>	243.	393.	453.	613.

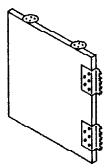

left hand shown

Endpanels, for use in building flush or cantilevered worksurfaces. All hardware included. 1 1/16" actual thickness	12"	1"	26 1/2"	<b>RE12F-( ) Half depth end panel</b>	177.	306.	352.	476.
	15"	1"	26 1/2"	<b>RE15F-( ) Half depth end panel</b>	190.	326.	375.	506.
	19"	1"	26 1/2"	<b>RE19F-( )</b>	205.	343.	393.	530.
	23"	1"	26 1/2"	<b>RE23F-( )</b>	216.	357.	413.	556.
	29"	1"	26 1/2"	<b>RE29F-( )</b>	229.	377.	433.	586.

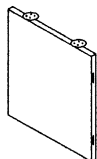

Order Code	Specification Information	Application Notes
Example: <b>RSE1(L)114</b>	<i>To order please specify pattern number including:</i>	Applicable finishes are listed on page 5 and 6.
<b>R</b> Reff		Modesty panel lengths are nominal - length changes on option selected.
<b>SE</b> End panel	<i>1. Finish type:</i>	Product on this page will accept woodgrain laminate where laminate is currently an option.
<b>1</b> 13" deep	L = Laminate	List price for woodgrain laminate options will be current published laminate list price plus 10%.
<b>L</b> Left hand	1 = V1	Modesty panels and end panels come with all hardware necessary to attach to tops and each other to build freestanding desks. To join tops to tops or bridge assemblies to desk, hardware must be ordered.
<b>L</b> Laminate	2 = V2	
<b>114</b> Folkstone grey	3 = V3	Modesty support for corner worksurface includes end panels 12"D to support in free standing applications.
	<i>2. Finish</i>	Please see Planning Guide for freestanding planning instruction.

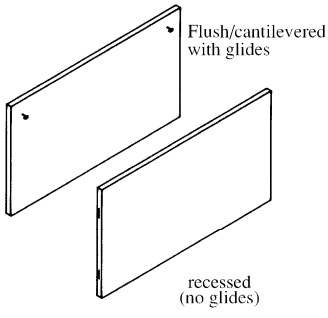

Top support components  
28<sup>3</sup>/<sub>8</sub>" high planning  
Modesty

description	d	w	h	pattern no.	L	V1	V2	V3
Modesty panels with hardware (desk height) 	1"	24"	28 <sup>3</sup> / <sub>8</sub> "	<b>RBDH24M(F/R) ( )( )</b>	\$157.	\$224.	\$255.	\$344.
	1"	30"	28 <sup>3</sup> / <sub>8</sub> "	<b>RBDH30M(F/R) ( )( )</b>	283.	401.	461.	621.
	1"	36"	28 <sup>3</sup> / <sub>8</sub> "	<b>RBDH36M(F/R) ( )( )</b>	315.	438.	502.	678.
	1"	42"	28 <sup>3</sup> / <sub>8</sub> "	<b>RBDH42M(F/R) ( )( )</b>	338.	475.	548.	739.
	1"	48"	28 <sup>3</sup> / <sub>8</sub> "	<b>RBDH48M(F/R) ( )( )</b>	380.	535.	615.	830.
	1"	54"	28 <sup>3</sup> / <sub>8</sub> "	<b>RBDH54M(F/R) ( )( )</b>	398.	561.	643.	868.
	1"	60"	28 <sup>3</sup> / <sub>8</sub> "	<b>RBDH60M(F/R) ( )( )</b>	414.	576.	664.	898.
	1"	66"	28 <sup>3</sup> / <sub>8</sub> "	<b>RBDH66M(F/R) ( )( )</b>	428.	604.	698.	942.
	1"	72"	28 <sup>3</sup> / <sub>8</sub> "	<b>RBDH72M(F/R) ( )( )</b>	473.	664.	764.	1,031.
	1"	78"	28 <sup>3</sup> / <sub>8</sub> "	<b>RBDH78M(F/R) ( )( )</b>	505.	706.	818.	1,105.
	1"	84"	28 <sup>3</sup> / <sub>8</sub> "	<b>RBDH84M(F/R) ( )( )</b>	535.	750.	862.	1,164.
	1"	90"	28 <sup>3</sup> / <sub>8</sub> "	<b>RBDH90M(F/R) ( )( )</b>	566.	794.	914.	1,233.
	1"	96"	28 <sup>3</sup> / <sub>8</sub> "	<b>RBDH96M(F/R) ( )( )</b>	577.	816.	935.	1,263.

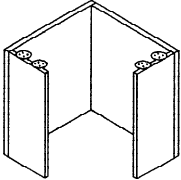
description	d	w	h	pattern no.	L	V1	V2	V3
Desk height corner worksurface support 	36"	36"	28 <sup>3</sup> / <sub>8</sub> "	<b>RBDH3636 ( )( )</b>	1,025.	1,521.	1,752.	2,364.
	36"	42"	28 <sup>3</sup> / <sub>8</sub> "	<b>RBDH3642 ( )( )</b>	1,048.	1,561.	1,795.	2,424.
	36"	48"	28 <sup>3</sup> / <sub>8</sub> "	<b>RBDH3648 ( )( )</b>	1,092.	1,619.	1,859.	2,511.
	42"	36"	28 <sup>3</sup> / <sub>8</sub> "	<b>RBDH4236 ( )( )</b>	1,048.	1,561.	1,795.	2,424.
	42"	42"	28 <sup>3</sup> / <sub>8</sub> "	<b>RBDH4242 ( )( )</b>	1,074.	1,598.	1,839.	2,483.
	42"	48"	28 <sup>3</sup> / <sub>8</sub> "	<b>RBDH4248 ( )( )</b>	1,117.	1,654.	1,908.	2,577.
	48"	36"	28 <sup>3</sup> / <sub>8</sub> "	<b>RBDH4836 ( )( )</b>	1,092.	1,619.	1,859.	2,511.
	48"	42"	28 <sup>3</sup> / <sub>8</sub> "	<b>RBDH4842 ( )( )</b>	1,117.	1,654.	1,908.	2,577.
	48"	48"	28 <sup>3</sup> / <sub>8</sub> "	<b>RBDH4848 ( )( )</b>	1,159.	1,717.	1,988.	2,684.

depth = left return, width = right return

Order Code

Example: <b>RBDH24MFL114</b>
<b>R</b> Reff
<b>B</b> Back panel/modesty
<b>DH</b> Desk height (28 <sup>3</sup> / <sub>8</sub> " )
<b>24</b> 24"
<b>M</b> Full height modesty
<b>F</b> Modesty placement, flush
<b>L</b> Finish type, laminate
<b>114</b> Finish, Folkstone grey

Specification Information

To order please specify pattern number including:

1. *Modesty placement*  
F = Flush, cantilevered  
R = Recessed
2. *Finish type*  
L = laminate  
1 = V1  
2 = V2  
3 = V3
3. *Finish*

Applicable finishes are listed on page 5 and 6.

Product on this page will accept woodgrain laminate where laminate is currently an option.  
List price for woodgrain laminate options will be current published laminate list price plus 10%.

Application Notes

**Products on this page are 28-3/8" high.** 28<sup>3</sup>/<sub>8</sub>"h "desk height" products should not be mixed with 26 1/2"h components. 28<sup>3</sup>/<sub>8</sub>"h components when used with 1 1/4" worksurfaces achieve overall desk height of 29 3/8"h. 28-3/8" "desk height" products may be specified for freestanding or panel based applications.

Modesty panels and end panels ship with all hardware necessary to attach to tops and each other to build freestanding desks. To join tops to tops or bridge assemblies to desk, hardware must be ordered separately.

Modesty support for corner worksurface includes 12" deep end panels to support in freestanding applications.

Modesty panel lengths are nominal, length changes on option selected.

\* Half depth end panels

Glides ship with all supports on this page except the recessed modesty panel.

Please see Reff Planning Guide for freestanding planning instructions.

Top support components  
28<sup>3</sup>/<sub>8</sub>" high planning  
End panels

description	d	w	h	pattern no.	L	V1	V2	V3
Desk height end panels with hardware for recessed modesty worksurfaces (sold in pairs)	1"	30"	28 <sup>3</sup> / <sub>8</sub> "	<b>REDH30</b> ( ) ( )	\$485.	\$789.	\$907.	\$1,224.
	1"	36"	28 <sup>3</sup> / <sub>8</sub> "	<b>REDH36</b> ( ) ( )	512.	826.	948.	1,281.

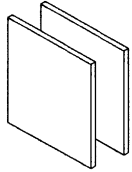

Desk height end panel for panel (hardware included)	1"	13"	28 <sup>3</sup> / <sub>8</sub> "	<b>RSEDH1(L/R)</b> ( ) ( )	184.	325.	370.	500.
	1"	16"	28 <sup>3</sup> / <sub>8</sub> "	<b>RSEDH2(L/R)</b> ( ) ( )	199.	342.	396.	535.
	1"	20"	28 <sup>3</sup> / <sub>8</sub> "	<b>RSEDH3(L/R)</b> ( ) ( )	215.	358.	413.	556.
	1"	24"	28 <sup>3</sup> / <sub>8</sub> "	<b>RSEDH4(L/R)</b> ( ) ( )	227.	375.	433.	586.
	1"	30"	28 <sup>3</sup> / <sub>8</sub> "	<b>RSEDH5(L/R)</b> ( ) ( )	241.	398.	454.	614.
	1"	36"	28 <sup>3</sup> / <sub>8</sub> "	<b>RSEDH6(L/R)</b> ( ) ( )	256.	413.	475.	642.

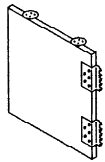

left hand shown

Desk height end panels with hardware for building flush or cantilevered worksurfaces	1"	12"	28 <sup>3</sup> / <sub>8</sub> "	<b>REDH12F</b> ( ) ( ) *	184.	325.	370.	500.
	1"	15"	28 <sup>3</sup> / <sub>8</sub> "	<b>REDH15F</b> ( ) ( ) *	199.	342.	396.	535.
	1"	19"	28 <sup>3</sup> / <sub>8</sub> "	<b>REDH19F</b> ( ) ( )	215.	358.	413.	556.
	1"	23"	28 <sup>3</sup> / <sub>8</sub> "	<b>REDH23F</b> ( ) ( )	227.	375.	433.	586.
	1"	29"	28 <sup>3</sup> / <sub>8</sub> "	<b>REDH29F</b> ( ) ( )	241.	398.	454.	614.

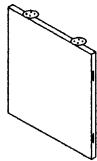

Order Code	Specification Information	Application Notes
Example: <b>REDH30</b>	<i>To order please specify pattern number including:</i>	<b>Products on this page are 28-3/8" high.</b> 28 <sup>3</sup> / <sub>8</sub> "h "desk height" products should not be mixed with 26 1/2"h components. 28 <sup>3</sup> / <sub>8</sub> "h components when used with 1 1/4" worksurfaces achieve overall desk height of 29 <sup>3</sup> / <sub>8</sub> "h. 28-3/8" "desk height" products may be specified for freestanding or panel based applications.
<b>R</b> Reff	1. <i>Finish type</i> L = laminate 1 = V1 2 = V2 3 = V3	Modesty support for corner worksurface includes 12" deep end panels to support in freestanding applications.
<b>E</b> End panel	2. <i>Finish</i>	Modesty panel lengths are nominal, length changes on option selected.
<b>DH</b> Desk height (28 <sup>3</sup> / <sub>8</sub> ")	Applicable finishes are listed on page 5 and 6.	* Half depth end panels
<b>30</b> 30"	Product on this page will accept woodgrain laminate where laminate is currently an option.	Glides ship with all supports on this page except the recessed modesty panel.
<b>L</b> Left hand	List price for woodgrain laminate options will be current published laminate list price plus 10%.	Please see Reff Planning Guide for freestanding planning instructions.
<b>L</b> Finish type, laminate		
<b>114</b> Finish, Folkstone grey		

# Top support components

## 28<sup>3</sup>/<sub>8</sub>" high planning

### Modesty and Bulkhead

description	d	w	h	pattern no.	L	V1	V2	V3
Desk height bow top front, short modesty (pedestals ordered separately)	1"	40"	28 <sup>3</sup> / <sub>8</sub> "	<b>RBDH40MR ( ) ( )</b>	\$338.	\$475.	\$548.	\$739.
	1"	52"	28 <sup>3</sup> / <sub>8</sub> "	<b>RBDH52MR ( ) ( )</b>	398.	561.	643.	868.
	1"	64"	28 <sup>3</sup> / <sub>8</sub> "	<b>RBDH64MR ( ) ( )</b>	428.	604.	698.	942.

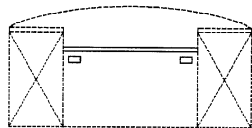

**Use of short modesty panel**

Pedestals and finished back for pedestal must each be ordered separately  
Short modesty comes with attachment brackets to secure modesty panel to sides of pedestals.

Order:

40" modesty for 72" bow top

52" modesty for 84" bow top

64" modesty for 96" bow top

When ordering 30"d bow top for use with short modesty, specify **recessed** grommet location

When ordering 36"d bow top for use with short modesty, specify **alternate** grommet location

description	d	w	h	pattern no.	L	V1	V2	V3
Desk height bulkhead (false pedestal)	24"	16"	28 <sup>3</sup> / <sub>8</sub> "	<b>REDHBH124 ( ) ( )</b>	477.	787.	914.	1,233.
	30"	16"	28 <sup>3</sup> / <sub>8</sub> "	<b>REDHBH130 ( ) ( )</b>	494.	803.	935.	1,263.

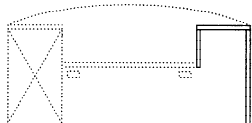

Bulkhead takes the place of a pedestal in applications using the short modesty panel but not requiring a double pedestal application





Support components

Order Code	Specification Information	Application Notes
Example: <b>RBDH24MFL114</b>	<i>To order please specify pattern number including:</i>	<b>Products on this page are 28-3/8" high.</b> 28 <sup>3</sup> / <sub>8</sub> "h "desk height" products should not be mixed with 26 1/2"h components. 28 <sup>3</sup> / <sub>8</sub> "h components when used with 1 1/4" worksurfaces achieve overall desk height of 29 3/8"h. 28-3/8" "desk height" products may be specified for freestanding or panel based applications.
<b>R</b> Reff	1. <i>Modesty placement</i> F = Flush, cantilevered R = Recessed	Modesty support for corner worksurface includes 12" deep end panels to support in freestanding applications.
<b>B</b> Back panel/modesty	2. <i>Finish type</i> L = laminate 1 = V1 2 = V2 3 = V3	Modesty panel lengths are nominal, length changes on option selected.
<b>DH</b> Desk height (28 <sup>3</sup> / <sub>8</sub> ")	3. <i>Finish</i>	* Half depth end panels
<b>24</b> 24"	Applicable finishes are listed on page 5 and 6.	Glides ship with all supports on this page except the recessed modesty panel.
<b>M</b> Full height modesty	Product on this page will accept woodgrain laminate where laminate is currently an option.	Please see Reff Planning Guide for freestanding planning instructions.
<b>F</b> Modesty placement, flush	List price for woodgrain laminate options will be current published laminate list price plus 10%.	
<b>L</b> Finish type, laminate		
<b>114</b> Finish, Folkstone grey		

# Top support components

## *Painted or Plated Legs 26 1/2" high planning*

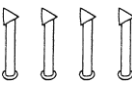
Reff Profiles

description	dia.	w	h	d	pattern no.	P1	P2	P3	metal
Column leg, Interaction style (rectangular plate) 	4"	-	26 1/2"	-	<b>RSC</b>	\$243.	\$256.	\$269.	\$243.
4" Plain Cylinder (26 1/2" high) 	4"	-	26 1/2"	-	<b>RCB</b>	255.	268.	280.	255.
Set of four column legs (4" dia.), Interaction style (triangular plate) 	4"	-	26 1/2"	-	<b>RSC4-()</b>	948.	994.	1,046.	948.
T-leg, Interaction style 	-	-	26 1/2"	24"	<b>RIB24T</b>	348.	365.	384.	348.
T-Leg, plain tube style 	-	-	26 1/2"	20"	<b>RCB20T-()</b>	376.	395.	414.	376.
	-	-	26 1/2"	24"	<b>RCB24T-()</b>	382.	404.	423.	382.
	-	-	26 1/2"	30"	<b>RCB30T-()</b>	423.	443.	467.	423.
	-	-	26 1/2"	40"	<b>RCB40T-()</b>	445.	469.	493.	445.

### Order Code

Example: **RSC**  
**R** Reff  
**S** Support  
**C** Cylinder

### Specification Information

*To order please specify pattern number including:*  
 1. Finish type, where applicable  
 2. Finish  
*Finish type options:*  
 P = Paint  
 M = Metal (plated)

### Application Notes



Cylinder bases, T-legs, X-bases are Knoll Interaction style. Trim ring will be black.  
 Interaction style cylinder base, column legs, T-leg, and X-base are not available in plated finishes.  
 Refer to Planning Guide for top-base matrix, pages 140 and 141.  
 All bases include 1 1/2" leveller.

Only the plain cylinder and tube legs can be ordered in plated finishes.  
 Applicable finishes are listed on page 5 and 6.

# Top support components

## *Painted or Plated Bases 26 1/2" high planning*

Reff Profiles

description	h	dia.	pattern no.	P1	P2	P3	metal
X-base 	26 1/2"	28"	<b>RIB28X-( )</b>	\$574.	\$604.	\$635.	\$574.
	26 1/2"	32"	<b>RIB32X-( )</b>	778.	819.	860.	778.
Spider base, plain tube style 	26 1/2"	24"	<b>RCB24X</b>	588.	618.	648.	588.
	26 1/2"	28"	<b>RCB28X</b>	616.	646.	678.	616.
	26 1/2"	36"	<b>RCB36X</b>	667.	702.	736.	667.
Drum base 	26 1/2"	–	<b>RSD1427-( )</b>	1,110.	1,166.	1,223.	1,110.
	26 1/2"	–	<b>RSD1827-( )</b>	1,206.	1,267.	1,329.	1,206.
	26 1/2"	–	<b>RSD2027-( )</b>	1,244.	1,306.	1,370.	1,244.
	26 1/2"	–	<b>RSD2427-( )</b>	1,489.	1,565.	1,642.	1,489.
	26 1/2"	–	<b>RSD3027-( )</b>	1,665.	1,747.	1,834.	1,665.

Support components

Order Code	Specification Information	Application Notes
Example: <b>RIB28X</b>	<i>To order please specify pattern number including:</i>	Cylinder bases, T-legs, X-bases are Knoll Interaction style. Trim ring will be black.
<b>R</b> Reff	1. Finish type, where applicable	
<b>I</b> Interaction	2. Finish	Interaction style cylinder base, column legs, T-leg, and X-base are not available in plated finishes.
<b>B</b> Base	<i>Finish type options:</i>	
<b>28</b> Diameter	P = Paint	Applicable finishes are listed on page 5 and 6.
<b>X</b> X-base	M = Metal (plated)	
		Refer to Planning Guide for top-base matrix, pages 140 and 141.
		All bases include 1 1/2" leveller.

# Top support components

## Laminate or Wood Bases 26<sup>1</sup>/<sub>2</sub>" high planning

Reff Profiles

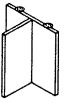
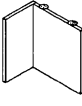
description	dia.	w	h	d	pattern no.	L	V1	V2	V3
 Drum base	14"		26 <sup>1</sup> / <sub>2</sub> "	–	<b>RSD1427-()</b>	n/a	\$1,297.	\$1,493.	\$2,016.
	18"		26 <sup>1</sup> / <sub>2</sub> "	–	<b>RSD1827-()</b>	n/a	1,409.	1,621.	2,190.
	20"		26 <sup>1</sup> / <sub>2</sub> "	–	<b>RSD2027-()</b>	n/a	1,455.	1,673.	2,258.
	24"		26 <sup>1</sup> / <sub>2</sub> "	–	<b>RSD2427-()</b>	n/a	1,744.	2,006.	2,708.
	30"		26 <sup>1</sup> / <sub>2</sub> "	–	<b>RSD3027-()</b>	n/a	1,949.	2,238.	3,021.
 T-base (hardware included)*	20"	26 <sup>1</sup> / <sub>2</sub> "	12"		<b>RST1-()</b>	415.	470.	549.	743.
	24"	26 <sup>1</sup> / <sub>2</sub> "	12"		<b>RST2-()</b>	444.	506.	581.	785.
	30"	26 <sup>1</sup> / <sub>2</sub> "	12"		<b>RST3-()</b>	522.	586.	679.	917.
	36"	26 <sup>1</sup> / <sub>2</sub> "	12"		<b>RST4-()</b>	593.	673.	772.	1,043.
	42"	26 <sup>1</sup> / <sub>2</sub> "	12"		<b>RST5-()</b>	658.	749.	863.	1,167.
	48"	26 <sup>1</sup> / <sub>2</sub> "	12"		<b>RST6-()</b>	734.	826.	954.	1,288.
 L-base (hardware included), non-handed*	12"	26 <sup>1</sup> / <sub>2</sub> "	12"		<b>RSL12-()</b>	415.	470.	549.	743.
	15"	26 <sup>1</sup> / <sub>2</sub> "	12"		<b>RSL15-()</b>	424.	481.	554.	748.
	20"	26 <sup>1</sup> / <sub>2</sub> "	12"		<b>RSL20-()</b>	444.	497.	574.	775.
	24"	26 <sup>1</sup> / <sub>2</sub> "	12"		<b>RSL24-()</b>	451.	506.	581.	785.
	30"	26 <sup>1</sup> / <sub>2</sub> "	12"		<b>RSL30-()</b>	522.	586.	679.	917.
	36"	26 <sup>1</sup> / <sub>2</sub> "	12"		<b>RSL36-()</b>	593.	673.	772.	1,043.
	42"	26 <sup>1</sup> / <sub>2</sub> "	12"		<b>RSL42-()</b>	658.	749.	863.	1,167.
	48"	26 <sup>1</sup> / <sub>2</sub> "	12"		<b>RSL48-()</b>	734.	826.	954.	1,288.

### Order Code

Example: <b>RSD1427</b>	
<b>R</b>	Reff
<b>S</b>	Support
<b>D</b>	Drum base
<b>14</b>	Diameter
<b>27</b>	Height
<b>2</b>	Finish type
<b>R319</b>	V2- Med. Cherry

### Specification Information

To order please specify pattern number including:

1. Finish type
2. Finish

Finish type options:

- L = Laminate  
 1 = V1  
 2 = V2  
 3 = V3

### Application Notes

Refer to Planning Guide for top-base matrix, pages 140 and 141.

All bases include 1<sup>1</sup>/<sub>2</sub>" leveller.

Product on this page will accept woodgrain laminate where laminate is currently an option.

List price for woodgrain laminate options will be current published laminate list price plus 10%.





T and L bases are not recommended for supporting conference tops.

Applicable finishes are listed on page 5 and 6.

# Top support components

## Painted or Plated Legs 28<sup>3</sup>/<sub>8</sub>" high planning

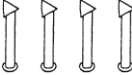
Reff Profiles

description	dia.	w	he	d	pattern no.	P1	P2	P3
Column Leg, Interaction style w/ rectangular plate (desk height)	4" dia	–	28 <sup>3</sup> / <sub>8</sub> "		<b>RSDHC ( ) ( )</b>	\$256.	\$269.	\$281.
								
4" Plain Cylinder (desk height)	4" dia	–	28 <sup>3</sup> / <sub>8</sub> "		<b>RCDHB ( ) ( )</b>	268.	280.	295.
								
Set of 4 Column legs, Interaction style w/triangular plate (desk height)	4" dia	–	28 <sup>3</sup> / <sub>8</sub> "		<b>RSDHC4 ( ) ( )</b>	996.	1,045.	1,098.
								
T-Leg, plain tube style (desk height)		–	28 <sup>3</sup> / <sub>8</sub> "	20"	<b>RCDHB20T ( ) ( )</b>	395.	415.	435.
		–	28 <sup>3</sup> / <sub>8</sub> "	24"	<b>RCDHB24T ( ) ( )</b>	403.	423.	444.
		–	28 <sup>3</sup> / <sub>8</sub> "	30"	<b>RCDHB30T ( ) ( )</b>	444.	467.	490.
		–	28 <sup>3</sup> / <sub>8</sub> "	40"	<b>RCDHB40T ( ) ( )</b>	469.	493.	517.
T-Leg, Interaction style (desk height)		–	28 <sup>3</sup> / <sub>8</sub> "	24"	<b>RIBDH24T ( ) ( )</b>	365.	384.	404.
								

Support components

Order Code	Specification Information	Application Notes
Example: <b>RSDHCP111</b>	<i>To order please specify pattern number including:</i>	Cylinder/column leg bases, T-Legs, X-bases are Knoll Interaction style. Trim ring will be black.
<b>R</b> Reff	1. <i>Finish Type, where applicable</i>	
<b>S</b> Support	P = Paint	
<b>DH</b> Desk Height	M = Metal (plated)	Interaction style cylinder base, column legs, T-leg and X-base are not available in plated finishes. Only the plain cylinder and the tube legs can be ordered in plated finishes.
<b>C</b> Column Leg	2. <i>Finish</i>	
<b>P</b> Finish type, paint	see matrix on page 5	
<b>111</b> Finish, Jet Black	Applicable finishes are listed on page 5 and 6.	All bases include 1 <sup>1</sup> / <sub>2</sub> " leveller.





Refer to Top to Base matrix, pages 140 and 141 in the Reff planning guide.

**Products on this page are 28-3/8" high.** 28<sup>3</sup>/<sub>8</sub>"h "desk height" products should not be mixed with 26<sup>1</sup>/<sub>2</sub>"h components. 28<sup>3</sup>/<sub>8</sub>"h components when used with 1<sup>1</sup>/<sub>4</sub>" worksurfaces achieve overall desk height of 29<sup>3</sup>/<sub>8</sub>"h. 28-3/8" "desk height" products may be specified for freestanding or panel based applications.

# Top support components

## *Painted or Plated Bases 28<sup>3</sup>/<sub>8</sub>" high planning*

Reff Profiles

description	dia.	w	h	d	pattern no.	P1	P2	P3
X-base (desk height) 		–	28 <sup>3</sup> / <sub>8</sub> "	28"	<b>RIBDH28X ( ) ( )</b>	\$604.	\$634.	\$666.
		–	28 <sup>3</sup> / <sub>8</sub> "	32"	<b>RIBDH32X ( ) ( )</b>	819.	859.	901.
Spider base, plain tube style (desk height) 		–	28 <sup>3</sup> / <sub>8</sub> "	24"	<b>RCBDH24X ( ) ( )</b>	618.	648.	680.
		–	28 <sup>3</sup> / <sub>8</sub> "	28"	<b>RCBDH28X ( ) ( )</b>	646.	678.	713.
		–	28 <sup>3</sup> / <sub>8</sub> "	36"	<b>RCBDH36X ( ) ( )</b>	702.	737.	772.
Drum Base (desk height) 	14"	–	28 <sup>3</sup> / <sub>8</sub> "	–	<b>RSDHD1428 ( ) ( )</b>	1,166.	1,223.	1,286.
	18"	–	28 <sup>3</sup> / <sub>8</sub> "	–	<b>RSDHD1828 ( ) ( )</b>	1,267.	1,329.	1,395.
	20"	–	28 <sup>3</sup> / <sub>8</sub> "	–	<b>RSDHD2028 ( ) ( )</b>	1,306.	1,370.	1,438.
	24"	–	28 <sup>3</sup> / <sub>8</sub> "	–	<b>RSDHD2428 ( ) ( )</b>	1,565.	1,642.	1,725.
	30"	–	28 <sup>3</sup> / <sub>8</sub> "	–	<b>RSDHD3028 ( ) ( )</b>	1,747.	1,835.	1,926.
Base Support Column, 3" dia. 			28 <sup>3</sup> / <sub>8</sub> "		<b>RSDHC3 ( ) ( )</b>	310.	310.	434.

Order Code	Specification Information	Application Notes
Example: <b>RCBDH24X</b>	<i>To order please specify pattern number including:</i>	Refer to Top to Base matrix, pages 140 and 141 in the Reff planning guide.
<b>R</b> Reff	1. <i>Finish Type, where applicable</i> P = Paint M = Metal (plated)	
<b>P</b> Finish type, paint	2. <i>Finish</i> see matrix on page 5	<b>Products on this page are 28-3/8" high.</b> 28 <sup>3</sup> / <sub>8</sub> "h "desk height" products should not be mixed with 26 <sup>1</sup> / <sub>2</sub> "h components. 28 <sup>3</sup> / <sub>8</sub> "h components when used with 1 <sup>1</sup> / <sub>4</sub> " worksurfaces achieve overall desk height of 29 <sup>3</sup> / <sub>8</sub> "h. 28-3/8" "desk height" products may be specified for freestanding or panel based applications.
<b>111</b> Finish, Jet Black	Applicable finishes are listed on page 5 and 6.	



# Top support components

## Laminate or Wood Bases 2/8<sup>3/8</sup>" high planning

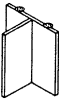
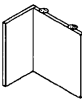

Reff Profiles

description	dia.	w	h	d	pattern no.	L	V1	V2	V3
 Drum Base (desk height)	14"	–	28 <sup>3/8</sup> "	–	<b>RSDHD1428</b> ( )( )	N/A	\$1,363.	\$1,567.	\$2,115.
	18"	–	28 <sup>3/8</sup> "	–	<b>RSDHD1828</b> ( )( )	N/A	1,481.	1,702.	2,299.
	20"	–	28 <sup>3/8</sup> "	–	<b>RSDHD2028</b> ( )( )	N/A	1,527.	1,755.	2,371.
	24"	–	28 <sup>3/8</sup> "	–	<b>RSDHD2428</b> ( )( )	N/A	1,830.	2,107.	2,845.
	30"	–	28 <sup>3/8</sup> "	–	<b>RSDHD3028</b> ( )( )	N/A	2,046.	2,350.	3,173.
 T-base, desk height (hardware included)	20"		28 <sup>3/8</sup> "	12"	<b>RSDHT1</b> ( )( )	436.	495.	575.	778.
	24"		28 <sup>3/8</sup> "	12"	<b>RSDHT2</b> ( )( )	468.	531.	611.	824.
	30"		28 <sup>3/8</sup> "	12"	<b>RSDHT3</b> ( )( )	548.	618.	713.	963.
	36"		28 <sup>3/8</sup> "	12"	<b>RSDHT4</b> ( )( )	623.	708.	812.	1,095.
	42"		28 <sup>3/8</sup> "	12"	<b>RSDHT5</b> ( )( )	691.	786.	907.	1,224.
	48"		28 <sup>3/8</sup> "	12"	<b>RSDHT6</b> ( )( )	770.	869.	1,002.	1,354.
 L-base, desk height (hardware included, non-handed)	12"		28 <sup>3/8</sup> "	12"	<b>RSDHL12</b> ( )( )	436.	495.	575.	778.
	15"		28 <sup>3/8</sup> "	12"	<b>RSDHL15</b> ( )( )	445.	502.	581.	785.
	20"		28 <sup>3/8</sup> "	12"	<b>RSDHL20</b> ( )( )	468.	521.	605.	817.
	24"		28 <sup>3/8</sup> "	12"	<b>RSDHL24</b> ( )( )	474.	531.	611.	824.
	30"		28 <sup>3/8</sup> "	12"	<b>RSDHL30</b> ( )( )	548.	618.	713.	963.
	36"		28 <sup>3/8</sup> "	12"	<b>RSDHL36</b> ( )( )	623.	708.	812.	1,095.
	42"		28 <sup>3/8</sup> "	12"	<b>RSDHL42</b> ( )( )	691.	786.	907.	1,224.
	48"		28 <sup>3/8</sup> "	12"	<b>RSDHL48</b> ( )( )	770.	869.	1,002.	1,354.

Support components

Order Code	Specification Information	Application Notes
Example: <b>RSDHD1428</b>	<i>To order please specify pattern number including:</i>	odT and L bases are not recommended for supporting conference tops.
<b>R</b> Reff	1. <i>Finish Type, where applicable</i>	All bases include 1/2" leveller.
<b>S</b> Support	L = Laminate	
<b>DH</b> Desk Height	1 = V1	Refer to Top to Base matrix, pages 140 and 141 in the Reff planning guide.  <b>Products on this page are 28-3/8" high.</b> 28 <sup>3/8</sup> "h "desk height" products should not be mixed with 26 1/2"h components. 28 <sup>3/8</sup> "h components when used with 1 1/4" worksurfaces achieve overall desk height of 29 <sup>3/8</sup> "h. 28-3/8" "desk height" products may be specified for freestanding or panel based applications.
<b>D</b> Drum base	2 = V2	
<b>14</b> Diameter	3 = V3	
<b>28</b> Height	2. <i>Finish</i>	
<b>2</b> Finish type, V2	see matrix on page 5	
<b>V316</b> Finish, Maple	Applicable finishes are listed on page 5 and 6.	

Modesty  
Removable  
28<sup>3</sup>/<sub>8</sub>" planning

description	application	th	w	h	pattern no.	L	V1	V2	V3
Removable Modesty for End panel and Storage Unit 	72" wide assembly - 16" storage	1"	72"	25"	<b>RDHMR7210</b>	\$351.	\$439.	\$505.	\$656.
	72" wide assembly - 19" storage	1"	72"	25"	<b>RDHMR7220</b>	346.	432.	497.	646.
	72" wide assembly - 30" storage	1"	72"	25"	<b>RDHMR7230</b>	322.	402.	462.	601.
	72" wide assembly - 36" storage	1"	72"	25"	<b>RDHMR7240</b>	311.	389.	447.	582.
	78" wide assembly - 16" storage	1"	78"	25"	<b>RDHMR7810</b>	361.	451.	519.	674.
	78" wide assembly - 19" storage	1"	78"	25"	<b>RDHMR7820</b>	356.	445.	511.	665.
	78" wide assembly - 30" storage	1"	78"	25"	<b>RDHMR7830</b>	332.	415.	477.	620.
	78" wide assembly - 36" storage	1"	78"	25"	<b>RDHMR7840</b>	322.	402.	462.	601.
	84" wide assembly - 16" storage	1"	84"	25"	<b>RDHMR8410</b>	376.	470.	541.	703.
	84" wide assembly - 19" storage	1"	84"	25"	<b>RDHMR8420</b>	366.	458.	526.	684.
	84" wide assembly - 30" storage	1"	84"	25"	<b>RDHMR8430</b>	347.	433.	498.	648.
	84" wide assembly - 36" storage	1"	84"	25"	<b>RDHMR8440</b>	332.	415.	477.	620.
	90" wide assembly - 16" storage	1"	90"	25"	<b>RDHMR9010</b>	386.	483.	555.	722.
	90" wide assembly - 19" storage	1"	90"	25"	<b>RDHMR9020</b>	381.	476.	547.	712.
	90" wide assembly - 30" storage	1"	90"	25"	<b>RDHMR9030</b>	357.	446.	513.	667.
	90" wide assembly - 36" storage	1"	90"	25"	<b>RDHMR9040</b>	347.	433.	498.	648.
	96" wide assembly - 16" storage	1"	96"	25"	<b>RDHMR9610</b>	401.	501.	577.	750.
	96" wide assembly - 19" storage	1"	96"	25"	<b>RDHMR9620</b>	391.	489.	562.	731.
	96" wide assembly - 30" storage	1"	96"	25"	<b>RDHMR9630</b>	367.	459.	528.	686.
	96" wide assembly - 36" storage	1"	96"	25"	<b>RDHMR9640</b>	357.	446.	513.	667.
Removable Modesty for Between Two Storage Elements 	72" wide assembly - 16"/16" storage	1"	72"	25"	<b>RDHMR7211</b>	321.	402.	462.	601.
	72" wide assembly - 16"/19" storage	1"	72"	25"	<b>RDHMR7212</b>	311.	398.	447.	582.
	72" wide assembly - 19"/19" storage	1"	72"	25"	<b>RDHMR7222</b>	316.	395.	454.	591.
	78" wide assembly - 16"/16" storage	1"	78"	25"	<b>RDHMR7811</b>	331.	414.	476.	619.
	78" wide assembly - 16"/19" storage	1"	78"	25"	<b>RDHMR7812</b>	326.	408.	469.	610.
	78" wide assembly - 19"/19" storage	1"	78"	25"	<b>RDHMR7822</b>	321.	402.	462.	601.
	84" wide assembly - 16"/16" storage	1"	84"	25"	<b>RDHMR8411</b>	346.	433.	498.	647.
	84" wide assembly - 16"/19" storage	1"	84"	25"	<b>RDHMR8412</b>	337.	421.	484.	629.
	84" wide assembly - 16"/30" storage	1"	84"	25"	<b>RDHMR8414</b>	318.	397.	457.	594.
	84" wide assembly - 19"/19" storage	1"	84"	25"	<b>RDHMR8422</b>	331.	414.	476.	619.
	84" wide assembly - 19"/30" storage	1"	84"	25"	<b>RDHMR8423</b>	312.	390.	449.	583.
	90" wide assembly - 16"/16" storage	1"	90"	25"	<b>RDHMR9011</b>	357.	446.	513.	667.
	90" wide assembly - 16"/19" storage	1"	90"	25"	<b>RDHMR9012</b>	352.	440.	506.	658.
	90" wide assembly - 16"/30" storage	1"	90"	25"	<b>RDHMR9014</b>	327.	409.	470.	611.

Order Code	Specification Information	Application Notes
Example: <b>RDHMR720</b>	<i>To order please specify pattern number including:</i>	Applicable finishes are listed on page 5 and 6.
<b>R</b> Reff	1. <i>Finish Type</i> L, V1, V2, V3	Product on this page will accept woodgrain laminate where laminate is currently an option.
<b>DH</b> Desk height	2. <i>Finish</i> V316	List price for woodgrain laminate options will be current published laminate list price plus 10%.
<b>M</b> Modesty	Installation instruction sheets available on line.	Modesty panels and end panels come with all hardware necessary to attach to tops and each other to build freestanding desks. To join tops to tops or bridge assemblies to desk, hardware must be ordered.
<b>R</b> Removable	For removable modesty refer to part number 6TP00084.	Modesty panel lengths are nominal - length changes on option selected.
<b>72</b> Width		Please see Planning Guide for freestanding planning instruction.
<b>10</b> 16" storage		Modesty End panel and storage unit.
<b>V2</b> Finish type		10= 16" storage 20= 19" storage 30= 30" storage 40= 36" storage Modesty between two storage units.
<b>V316</b> Light Maple		11= 16"/16" storage 12= 16"/16" storage 13= 16"/36" storage 14= 16"/30" storage 22= 19"/19" storage 23= 19"/30" storage 24= 19"/36" storage 33= 30"/30" storage

Modesty  
Removable  
28<sup>3</sup>/<sub>8</sub>" planning

description	application	th	w	h	pattern no.	L	V1	V2	V3
Removable Modesty for Between Two Storage Elements 	90" wide assembly - 16"/36" storage	1"	90"	25"	<b>RDHMR9013</b>	\$318.	\$397.	\$457.	\$594.
	90" wide assembly - 19"/19" storage	1"	90"	25"	<b>RDHMR9022</b>	346.	433.	498.	647.
	90" wide assembly - 19"/30" storage	1"	90"	25"	<b>RDHMR9023</b>	322.	403.	464.	603.
	90" wide assembly - 19"/36" storage	1"	90"	25"	<b>RDHMR9024</b>	312.	390.	449.	583.
	96" wide assembly - 16"/16" storage	1"	96"	25"	<b>RDHMR9611</b>	367.	459.	528.	686.
	96" wide assembly - 16"/19" storage	1"	96"	25"	<b>RDHMR9612</b>	361.	452.	520.	676.
	96" wide assembly - 16"/30" storage	1"	96"	25"	<b>RDHMR9614</b>	343.	428.	493.	640.
	96" wide assembly - 16"/36" storage	1"	96"	25"	<b>RDHMR9613</b>	327.	409.	470.	611.
	96" wide assembly - 19"/19" storage	1"	96"	25"	<b>RDHMR9622</b>	357.	446.	513.	667.
	96" wide assembly - 19"/30" storage	1"	96"	25"	<b>RDHMR9623</b>	333.	416.	479.	622.
	96" wide assembly - 19"/36" storage	1"	96"	25"	<b>RDHMR9624</b>	322.	403.	464.	603.
	96" wide assembly - 30"/30" storage	1"	96"	25"	<b>RDHMR9633</b>	313.	391.	450.	585.

Order Code	Specification Information	Application Notes
Example: <b>RDHMR720</b>	<i>To order please specify pattern number including:</i>	Applicable finishes are listed on page 5 and 6.
<b>R</b> Reff	1. <i>Finish Type</i> L, V1, V2, V3	Product on this page will accept woodgrain laminate where laminate is currently an option.
<b>DH</b> Desk height	2. <i>Finish</i> V316	List price for woodgrain laminate options will be current published laminate list price plus 10%.
<b>M</b> Modesty	Installation instruction sheets available on line.	Modesty panels and end panels come with all hardware necessary to attach to tops and each other to build freestanding desks. To join tops to tops or bridge assemblies to desk, hardware must be ordered.
<b>R</b> Removable	For removable modesty refer to part number 6TP00034.	Modesty panel lengths are nominal - length changes on option selected.
<b>72</b> Width		Please see Planning Guide for freestanding planning instruction.
<b>10</b> 16" storage		Modesty End panel and storage unit.
<b>V2</b> Finish type		10= 16" storage
<b>V316</b> Light Maple		20= 19" storage
		30= 30" storage
		40= 36" storage
		Modesty between two storage units.
		11= 16"/16" storage
		12= 16"/16" storage
		13= 16"/36" storage
		14= 16"/30" storage
		22= 19"/19" storage
		23= 19"/30" storage
		24= 19"/36" storage
		33= 30"/30" storage

# Modesty

## Hinged

### 28<sup>3</sup>/<sub>8</sub>" planning

description	application	th	w	h	pattern no.	L	V1	V2	V3
Hinged Modesty for Between Two Storage Elements 	72" wide assembly - 16"/16" storage	1"	72"	25"	<b>RDHMH7211</b>	\$611.	\$778.	\$819.	\$983.
	72" wide assembly - 16"/19" storage	1"	72"	25"	<b>RDHMH7222</b>	601.	768.	804.	965.
	72" wide assembly - 19"/19" storage	1"	72"	25"	<b>RDHMH7212</b>	605.	773.	811.	973.
	78" wide assembly - 16"/16" storage	1"	78"	25"	<b>RDHMH7811</b>	622.	793.	834.	1,001.
	78" wide assembly - 16"/19" storage	1"	78"	25"	<b>RDHMH7812</b>	616.	788.	827.	992.
	78" wide assembly - 16"/30" storage	1"	78"	25"	<b>RDHMH7813</b>	596.	764.	793.	952.
	78" wide assembly - 19"/30" storage	1"	78"	25"	<b>RDHMH7822</b>	611.	778.	819.	983.
	78" wide assembly - 19"/30" storage	1"	78"	25"	<b>RDHMH7823</b>	591.	759.	781.	937.
	84" wide assembly - 16"/16" storage	1"	84"	25"	<b>RDHMH8411</b>	761.	932.	978.	1,174.
	84" wide assembly - 16"/19" storage	1"	84"	25"	<b>RDHMH8412</b>	755.	927.	970.	1,164.
	84" wide assembly - 16"/30" storage	1"	84"	25"	<b>RDHMH8414</b>	596.	764.	793.	952.
	84" wide assembly - 16"/36" storage	1"	84"	25"	<b>RDHMH8413</b>	607.	774.	813.	976.
	84" wide assembly - 19"/19" storage	1"	84"	25"	<b>RDHMH8422</b>	622.	793.	834.	1,001.
	84" wide assembly - 19"/30" storage	1"	84"	25"	<b>RDHMH8423</b>	601.	768.	806.	967.
	84" wide assembly - 19"/36" storage	1"	84"	25"	<b>RDHMH8424</b>	591.	759.	781.	937.
	90" wide assembly - 16"/16" storage	1"	90"	25"	<b>RDHMH9011</b>	772.	942.	992.	1,190.
	90" wide assembly - 16"/19" storage	1"	90"	25"	<b>RDHMH9012</b>	766.	937.	985.	1,182.
	90" wide assembly - 16"/30" storage	1"	90"	25"	<b>RDHMH9014</b>	607.	774.	813.	976.
	90" wide assembly - 16"/36" storage	1"	90"	25"	<b>RDHMH9013</b>	617.	789.	828.	994.
	90" wide assembly - 19"/19" storage	1"	90"	25"	<b>RDHMH9022</b>	761.	932.	978.	1,174.
	90" wide assembly - 19"/30" storage	1"	90"	25"	<b>RDHMH9023</b>	612.	779.	820.	984.
	90" wide assembly - 19"/36" storage	1"	90"	25"	<b>RDHMH9024</b>	601.	768.	806.	967.
	90" wide assembly - 30"/30" storage	1"	90"	25"	<b>RDHMH9033</b>	592.	760.	783.	940.
	96" wide assembly - 16"/16" storage	1"	96"	25"	<b>RDHMH9611</b>	786.	951.	1,013.	1,216.
	96" wide assembly - 16"/19" storage	1"	96"	25"	<b>RDHMH9612</b>	781.	947.	1,000.	1,200.
	96" wide assembly - 16"/30" storage	1"	96"	25"	<b>RDHMH9614</b>	617.	789.	828.	994.
	96" wide assembly - 16"/36" storage	1"	96"	25"	<b>RDHMH9613</b>	757.	928.	971.	1,165.
	96" wide assembly - 19"/19" storage	1"	96"	25"	<b>RDHMH9622</b>	772.	942.	992.	1,190.
	96" wide assembly - 19"/30" storage	1"	96"	25"	<b>RDHMH9623</b>	662.	794.	835.	1,002.
	96" wide assembly - 19"/36" storage	1"	96"	25"	<b>RDHMH9624</b>	612.	779.	820.	984.
96" wide assembly - 30"/30" storage	1"	96"	25"	<b>RDHMH9633</b>	603.	770.	807.	968.	

Hinged Modesty for End panel and Storage Unit 	72" wide assembly - 16" storage	1"	72"	25"	<b>RDHMH7210</b>	766.	936.	984.	1,181.
	72" wide assembly - 19" storage	1"	72"	25"	<b>RDHMH7220</b>	760.	932.	977.	1,172.
	72" wide assembly - 30" storage	1"	72"	25"	<b>RDHMH7230</b>	611.	778.	820.	984.
	72" wide assembly - 36" storage	1"	72"	25"	<b>RDHMH7240</b>	601.	768.	804.	965.
	78" wide assembly - 16" storage	1"	78"	25"	<b>RDHMH7810</b>	780.	946.	999.	1,199.
	78" wide assembly - 19" storage	1"	78"	25"	<b>RDHMH7820</b>	770.	941.	991.	1,189.
	78" wide assembly - 30" storage	1"	78"	25"	<b>RDHMH7830</b>	622.	793.	834.	1,001.
	78" wide assembly - 36" storage	1"	78"	25"	<b>RDHMH7840</b>	611.	778.	820.	984.

Order Code	Specification Information	Application Notes	
Example: <b>RDHMH7222</b>	To order please specify pattern number including: 1. <i>Finish Type</i> L, V1, V2, V3 2. <i>Finish</i> V316	Modesty may prohibit the adjacent drawer from opening.  Recommended that when using a modesty the adjacent ped is an open configuration.  Hardware shipped with modesty to attach to worksurface.  J-Extrusion Wire Trough sold separately.	
<b>R</b> Reff			Modesty End panel and storage unit.  10= 16" storage 20= 19" storage 30= 30" storage 40= 36" storage Modesty between two storage units. 11= 16"/16" storage 12= 16"/19" storage 13= 16"/36" storage 14= 16"/30" storage 22= 19"/19" storage 23= 19"/30" storage 24= 19"/36" storage 33= 30"/30" storage
<b>DH</b> Desk height			
<b>M</b> Modesty			
<b>H</b> Hinged			
<b>72</b> Width			
<b>22</b> 19"/19" storage			
<b>V2</b> Finish type			
<b>V316</b> Light Maple			

Modesty  
Hinged  
28<sup>3</sup>/<sub>8</sub>" planning

description	application	th	w	h	pattern no.	L	V1	V2	V3
 Hinged Modesty for End panel and Storage Unit	84" wide assembly - 16" storage	1"	84"	25"	<b>RDHMH8410</b>	\$794.	\$963.	\$1,019.	\$1,223.
	84" wide assembly - 19" storage	1"	84"	25"	<b>RDHMH8420</b>	785.	950.	1,012.	1,214.
	84" wide assembly - 30" storage	1"	84"	25"	<b>RDHMH8430</b>	761.	932.	978.	1,174.
	84" wide assembly - 36" storage	1"	84"	25"	<b>RDHMH8440</b>	622.	793.	834.	1,001.
	90" wide assembly - 16" storage	1"	90"	25"	<b>RDHMH9010</b>	804.	972.	1,034.	1,241.
	90" wide assembly - 19" storage	1"	90"	25"	<b>RDHMH9020</b>	798.	967.	1,027.	1,232.
	90" wide assembly - 30" storage	1"	90"	25"	<b>RDHMH9030</b>	772.	942.	992.	1,190.
	90" wide assembly - 36" storage	1"	90"	25"	<b>RDHMH9040</b>	761.	932.	978.	1,174.
	96" wide assembly - 16" storage	1"	96"	25"	<b>RDHMH9610</b>	815.	982.	1,049.	1,259.
	96" wide assembly - 19" storage	1"	96"	25"	<b>RDHMH9620</b>	809.	977.	1,041.	1,249.
	96" wide assembly - 30" storage	1"	96"	25"	<b>RDHMH9630</b>	786.	952.	1,014.	1,217.
	96" wide assembly - 36" storage	1"	96"	25"	<b>RDHMH9640</b>	772.	942.	992.	1,190.

Order Code	Specification Information	Application Notes	
Example: <b>RDHMH7222</b>	<i>To order please specify pattern number including:</i> 1. <i>Finish Type</i> L, V1, V2, V3 2. <i>Finish</i> V316	Modesty may prohibit the adjacent drawer from opening.  Recommended that when using a modesty the adjacent ped is an open configuration.  Hardware shipped with modesty to attach to worksurface.  J-Extrusion Wire Trough sold separately.	
<b>R</b> Reff			Modesty End panel and storage unit.  10= 16" storage 20= 19" storage 30= 30" storage 40= 36" storage Modesty between two storage units. 11= 16"/16" storage 12= 16"/19" storage 13= 16"/36" storage 14= 16"/30" storage 22= 19"/19" storage 23= 19"/30" storage 24= 19"/36" storage 33= 30"/30" storage
<b>DH</b> Desk height			
<b>M</b> Modesty			
<b>H</b> Hinged			
<b>72</b> Width			
<b>22</b> 19"/19" storage			
<b>V2</b> Finish type			
<b>V316</b> Light Maple			

Modesty  
*Partial*  
*28<sup>3</sup>/<sub>8</sub>" planning*

description	th	w	h	pattern no.	L	V1	V2	V3
Partial / Half Height Modesty	1"	26"	12"	<b>RDHPM26 ( )</b>	\$280.	\$391.	\$450.	\$585.
	1"	32"	12"	<b>RDHPM32 ( )</b>	289.	404.	465.	604.
	1"	38"	12"	<b>RDHPM38 ( )</b>	304.	426.	490.	636.
	1"	44"	12"	<b>RDHPM44 ( )</b>	320.	448.	515.	670.
	1"	50"	12"	<b>RDHPM50 ( )</b>	343.	480.	552.	718.
	1"	56"	12"	<b>RDHPM56 ( )</b>	352.	493.	567.	738.
	1"	62"	12"	<b>RDHPM62 ( )</b>	378.	529.	609.	791.
	1"	68"	12"	<b>RDHPM68 ( )</b>	399.	559.	643.	835.
	1"	74"	12"	<b>RDHPM74 ( )</b>	408.	572.	657.	854.

**Order Code**

Example: <b>RDHPM26( )</b>	
<b>R</b>	Reff
<b>DH</b>	Desk height
<b>PM</b>	Partial Modesty
<b>26</b>	Width
<b>V316</b>	Light Maple

**Specification Information**

*To order please specify pattern number including:*

1. Finish  
L, V1, V2, V3

**Application Notes**

Modesty may prohibit the adjacent drawer from opening.

Recommended that when using a modesty the adjacent ped is an open configuration.

Hardware shipped with modesty to attach to worksurface.

J-Extrusion Wire Trough sold separately.

# Pedestals, 26 1/2" planning

## BBF/FF

### Metal interiors

description	w	d	h	pattern no.	metal interiors L	metal interiors V1	metal interiors V2	metal interiors V3
Pedestal with box box file configuration	16"	19"	26 1/2"	<b>RP211J-( ) ( ) L</b>	\$1,131.	\$1,210.	\$1,388.	\$1,867.
	16"	23"	26 1/2"	<b>RP212J-( ) ( ) L</b>	1,181.	1,265.	1,453.	1,954.
	16"	29"	26 1/2"	<b>RP213J-( ) ( ) L</b>	1,231.	1,317.	1,513.	2,036.

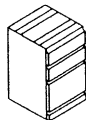

\*Pencil tray not included  
 \*Pedestals may require counterweights when used in unsecured fashion (i.e. freestanding).  
 \*3 Counter weights required per pedestal.

description	w	d	h	pattern no.	metal interiors L	metal interiors V1	metal interiors V2	metal interiors V3
Pedestal with file file configuration	16"	19"	26 1/2"	<b>RP211K-( ) ( ) L</b>	1,036.	1,111.	1,277.	1,725.
	16"	23"	26 1/2"	<b>RP212K-( ) ( ) L</b>	1,111.	1,190.	1,368.	1,847.
	16"	29"	26 1/2"	<b>RP213K-( ) ( ) L</b>	1,182.	1,264.	1,456.	1,964.
	30"	19"	26 1/2"	<b>RP231K-( ) ( ) L</b>	1,184.	1,271.	1,461.	1,973.
	30"	23"	26 1/2"	<b>RP232K-( ) ( ) L</b>	1,248.	1,340.	1,538.	2,076.
	36"	19"	26 1/2"	<b>RP261K-( ) ( ) L</b>	1,263.	1,354.	1,558.	2,103.
	36"	23"	26 1/2"	<b>RP262K-( ) ( ) L</b>	1,324.	1,419.	1,633.	2,205.

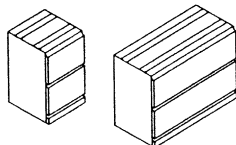

\*Pencil tray not included  
 \*Pedestals may require counterweights when used in unsecured fashion (i.e. freestanding).  
 \*3 Counter weights required per pedestal.

Order Code	Specification Information	Application Notes
Example: <b>RP211JLMDL</b>	<i>To order please specify pattern number including:</i>	<i>3. Pull options:</i>
<b>R</b> Reff	1. Finish type	D = Metal D-pull
<b>P</b> Pedestal	2. Interior option	J = Routed pull
<b>2</b> 26 1/2"H	3. Pull option	C = Nickel C-pull (nickel finish only)
<b>1</b> 16" wide	4. Lock option, Files	S = S-pull (stainless steel finish only)
<b>1</b> 19" deep	5. Cabinet Finish	F = Bar pull
<b>J</b> Box box file config.	6. Pull Finish	H = Outline pull
<b>L</b> Laminate finish	Painted or Plated	T = Tab pull
<b>M</b> Metal interior	<b>*After specifying product code, provide keying instructions.</b>	R = Cylinder pull
<b>D</b> Metal D-pull	<i>1. Finish type:</i>	<i>4. Lock options:</i>
<b>L</b> Lock option files	L = Laminate	L = Drilled to accept lock
<b>114</b> Cabinet Finish, Folkstone Grey	1 = V1	Lock default is Black
<b>612</b> Pull Finish, Folkstone Grey	2 = V2	5. Refer to page 523 for keying instructions.
	3 = V3	Pencil tray to be ordered separately; see page 425.
	<i>2. Interior options:</i>	Pedestals must be ordered with back panel to achieve full depth without a modesty panel.
	M = Metal (If laminate case finish-shelves painted to match; if V1,V2 or V3 case finish-shelves painted black; drawer interiors painted black metal)	

**Pedestals do not come with lock included. Keying instructions must accompany all cabinet orders.**

Mobile pedestals are always equipped with finished backs.

File drawers include file bars for front to back and side to side filing. File drawers do not support bottom loading.

Random locks are factory installed.

Keyalike are field installed using the KnollKey order form.

Each locking pedestal on this page counts for one lock core.

Each pedestal may require 3 counterweights when used in unsecured fashion (ie. Freestanding)

1 counterweight = 10 lbs.

Applicable finishes are listed on page 5 and 6.

Product on this page excluding J-pull option will accept woodgrain laminate where laminate is currently an option.

List price for woodgrain laminate options will be current published laminate list price plus 10%.

# Pedestals, 26 1/2" planning

## BBF/FF

### Metal interiors and wood backs

description	w	d	h	pattern no.	metal interiors L	metal interiors V1	metal interiors V2	metal interiors V3
Pedestal with box box file configuration	16"	20"	26 1/2"	<b>RPB211J</b> ( ) ( ) <b>L</b>	\$1,258.	\$1,346.	\$1,550.	\$2,084.
	16"	24"	26 1/2"	<b>RPB212J</b> ( ) ( ) <b>L</b>	1,308.	1,402.	1,611.	2,167.
	16"	30"	26 1/2"	<b>RPB213J</b> ( ) ( ) <b>L</b>	1,359.	1,456.	1,673.	2,253.

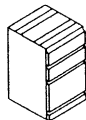

\*Pencil Tray not included

\*Pedestals may require counterweights when used in unsecured fashion (i.e. freestanding).

\*3 counterweights per pedestal.

description	w	d	h	pattern no.	metal interiors L	metal interiors V1	metal interiors V2	metal interiors V3
Pedestal with file file configuration	16"	20"	26 1/2"	<b>RPB211K</b> ( ) ( ) <b>L</b>	1,164.	1,247.	1,437.	1,941.
	16"	24"	26 1/2"	<b>RPB212K</b> ( ) ( ) <b>L</b>	1,238.	1,326.	1,530.	2,064.
	16"	30"	26 1/2"	<b>RPB213K</b> ( ) ( ) <b>L</b>	1,312.	1,404.	1,615.	2,181.
	30"	20"	26 1/2"	<b>RPB231K</b> ( ) ( ) <b>L</b>	1,440.	1,545.	1,773.	2,395.
	30"	24"	26 1/2"	<b>RPB232K</b> ( ) ( ) <b>L</b>	1,504.	1,613.	1,850.	2,497.
	36"	20"	26 1/2"	<b>RPB261K</b> ( ) ( ) <b>L</b>	1,564.	1,681.	1,930.	2,606.
	36"	24"	26 1/2"	<b>RPB262K</b> ( ) ( ) <b>L</b>	1,629.	1,745.	2,006.	2,707.

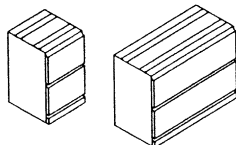

\*Pencil Tray not included

\*Pedestals may require counterweights when used in unsecured fashion (i.e. freestanding).

\*3 counterweights per pedestal.

Order Code	Specification Information
Example: <b>RPB211JLMDL</b>	
<b>R</b>	Reff
<b>PB</b>	Pedestal with back
<b>2</b>	26 1/2"H
<b>1</b>	16" wide
<b>1</b>	20" deep
<b>J</b>	Box box file config.
<b>L</b>	Laminate finish
<b>M</b>	Metal interior
<b>D</b>	Metal D-pull
<b>L</b>	Lock hole drilled
<b>114</b>	Cabint finish
<b>612</b>	Pull finish

Specification Information	Application Notes
<i>To order please specify pattern number including:</i>	
1. Hinge location, where applicable	3. Pull options: D = Metal D-pull J = Routed pull C = Nickel C-pull (nickel finish only) S = S-pull (stainless steel finish only) F = Bar pull H = Outline pull R = Cylinder pull T = Tab pull
2. Finish type	
3. Interior option	
4. Pull option	
5. Lock option, files	
6. Cabinet finish	
7. Pull Finish Painted or Plated	
<b>*After specifying product code, provide keying instructions.</b>	
1. <i>Finish type:</i> L = Laminate 1 = V1 2 = V2 3 = V3	

Application Notes
4. <i>Lock options:</i> Pedestals with drawers always lock drilled. L = Drilled to accept lock Lock default is Black
5. Refer to page 523 for keying instructions.
Each pedestal with wood drawers includes one pencil tray and two tray dividers in top box drawer. Metal drawer pedestals have one pencil tray.
<b>Pedestals do not come with lock included. Keying instructions must accompany all cabinet orders.</b>
Hinge door cabinets have optional lock drilling which can be specified in the cabinet product code.
File drawers include file bars for front to back and side to side filing. File drawers do not support bottom loading.
Random locks are factory installed.
Keyalike are field installed using the KnollKey order form.
Each locking pedestal on this page counts for one lock core.
Pedestals must be ordered with back-panel to achieve full depth, without a modesty panel.
1 counterweight = 10 lbs.

Applicable finishes are listed on page 5 and 6.



# Pedestals, 26 1/2" planning

## BBF/FF

### Metal interiors legal width

description	w	d	h	pattern no.	metal interiors L	metal interiors V1	metal interiors V2	metal interiors V3
Pedestal with box box file configuration	19"	19"	26 1/2"	RP221J( ) ( ) ( )	\$1,186.	\$1,269.	\$1,457.	\$1,960.
	19"	23"	26 1/2"	RP222J( ) ( ) ( )	1,239.	1,328.	1,525.	2,051.
	19"	29"	26 1/2"	RP223J( ) ( ) ( )	1,291.	1,382.	1,588.	2,157.

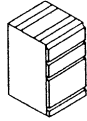

\*Pencil tray not included  
 \*Pedestals may require counterweights when used in unsecured fashion (i.e. freestanding).  
 \*3 counterweights per pedestal

Pedestal with file file configuration	19"	19"	26 1/2"	RP221K( ) ( ) ( )	1,088.	1,166.	1,341.	1,811.
	19"	23"	26 1/2"	RP222K( ) ( ) ( )	1,166.	1,249.	1,437.	1,940.
	19"	29"	26 1/2"	RP223K( ) ( ) ( )	1,241.	1,328.	1,529.	2,062.

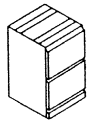

\*Pencil tray not included  
 \*Pedestals may require counterweights when used in unsecured fashion (i.e. freestanding).  
 \*3 counterweights per pedestal

Order Code	Specification Information	Application Notes
Example: <b>RP221JLMDL</b> <b>R</b> Reff <b>P</b> Pedestal <b>2</b> 26 1/2"H <b>2</b> 19" wide <b>1</b> 19" deep <b>J</b> Box box file config. <b>L</b> Laminate finish <b>M</b> Metal interior <b>D</b> Metal D-pull <b>L</b> Lock option <b>114</b> Cabinet Finish, Folkstone grey <b>612</b> Pull Finish, Med. grey	<p><i>To order please specify pattern number including:</i></p> <ol style="list-style-type: none"> <li>1. Finish type</li> <li>2. Interior option</li> <li>3. Pull option</li> <li>4. Lock option, Files</li> <li>5. Cabinet finish</li> <li>6. Pull Finish Painted or Plated</li> </ol> <p><b>*After specifying product code, provide keying instructions.</b></p> <p><i>1. Finish type:</i>                      L = Laminate                      1 = V1                      2 = V2                      3 = V3</p> <p><i>2. Interior options:</i>                      M = Metal (If laminate case finish-shelves painted to match; if V1, V2 or V3 case finish-shelves painted black; drawer interiors painted black metal)</p>	<p><i>3. Pull options:</i>                      D = Metal D-pull                      J = Routed pull                      C = Nickel C-pull (nickel finish only)                      S = S-pull (stainless steel finish only)                      F = Bar pull                      H = Outline pull                      R = Cylinder pull                      T = Tab pull</p> <p><i>4. Lock options:</i>                      L = Drilled to accept lock                      Lock default is Black</p> <p><i>5. Cabinet Finish</i></p> <p><i>6. Pull Finish</i></p> <p><i>7. Refer to page 523 for keying instructions.</i></p> <p>Pencil tray to be ordered separately; see page 425.</p> <p>Pedestals must be ordered with back panel to achieve full depth without a modesty panel.</p>

Applicable finishes are listed on page 5 and 6.

Product on this page excluding J-pull option will accept woodgrain laminate where laminate is currently an option.

List price for woodgrain laminate options will be current published laminate list price plus 10%.

**Pedestals do not come with lock included. Keying instructions must accompany all cabinet orders.**

File drawers include file bars for front to back and side to side filing. File drawers do not support bottom loading.

Random locks are factory installed.

Keyalike are field installed using the KnollKey order form.

Each locking pedestal on this page counts for one lock core.

Each pedestal may require 3 counterweights when used in unsecure fashion. (ie. Freestanding)

1 counterweight = 10 lbs.

# Pedestals, 26 1/2" planning

## BBF/FF

### Wood interior

description	w	d	h	pattern no.	wood interiors L	wood interiors V1	wood interiors V2	wood interiors V3	list
Pedestal with box box file configuration	16"	19"	26 1/2"	RP211J-( ) ( ) L	\$1,199.	\$1,281.	\$1,473.	\$1,980.	
	16"	23"	26 1/2"	RP212J-( ) ( ) L	1,332.	1,427.	1,637.	2,204.	
	16"	29"	26 1/2"	RP213J-( ) ( ) L	1,449.	1,552.	1,782.	2,398.	

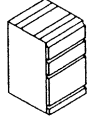

\*Pedestals may require counterweights when used in unsecured fashion (i.e. freestanding).  
3 counterweights per pedestal.

description	w	d	h	pattern no.	wood interiors L	wood interiors V1	wood interiors V2	wood interiors V3	list
Pedestal with file file configuration	16"	19"	26 1/2"	RP211K-( ) ( ) L	1,097.	1,176.	1,350.	1,824.	
	16"	23"	26 1/2"	RP212K-( ) ( ) L	1,294.	1,387.	1,592.	2,149.	
	16"	29"	26 1/2"	RP213K-( ) ( ) L	1,411.	1,514.	1,740.	2,350.	
	30"	19"	26 1/2"	RP231K-( ) ( ) L	1,418.	1,520.	1,748.	2,359.	
	30"	23"	26 1/2"	RP232K-( ) ( ) L	1,668.	1,786.	2,050.	2,768.	
	36"	19"	26 1/2"	RP261K-( ) ( ) L	1,754.	1,879.	2,162.	2,918.	
	36"	23"	26 1/2"	RP262K-( ) ( ) L	2,043.	2,191.	2,520.	3,401.	

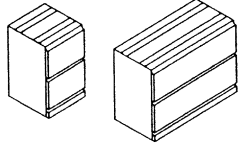

\*Pedestals may require counterweights when used in unsecured fashion (i.e. freestanding).  
3 counterweights per pedestal.

Order Code	Specification Information	Application Notes
Example: <b>RP211JLWDL</b>	<i>To order please specify pattern number including:</i>	<i>3. Pull options:</i>
<b>R</b> Reff	1. Finish type	D = Metal D-pull
<b>P</b> Pedestal	2. Interior option	J = Routed pull
<b>2</b> 26 1/2"H	3. Pull option	C = Nickel C-pull (nickel finish only)
<b>1</b> 16" wide	4. Lock option, file	S = S-pull (stainless steel finish only)
<b>1</b> 19" deep	5. Cabinet finish	H = Outline pull
<b>J</b> Box box file config.	6. Pull finish	T = Tab pull
<b>L</b> Laminate finish	<b>*After specifying product code, provide keying instructions.</b>	R = Cylinder pull
<b>W</b> Wood interior	<i>1. Finish type:</i>	F = Bar pull
<b>D</b> Metal D-pull	L = Laminate	<i>4. Lock options:</i>
<b>L</b> Lock hole drilled	1 = V1	Pedestals with drawers always lock drilled.
<b>114</b> Cabinet finish	2 = V2	Lock default is Black
<b>612</b> Pull finish	3 = V3	L = Drilled to accept lock
	<i>2. Interior options:</i>	<i>5. Refer to page 523 for keying instructions.</i>
	W = Wood (shelves match case finish: L, V1, V2 or V3; drawer interiors cherry veneer)	Each pedestal with wood drawers includes one pencil tray and two tray dividers in top box drawer.

**Pedestals do not come with lock included. Keying instructions must accompany all cabinet orders.**

Hinge door cabinets have optional lock drilling which can be specified in the cabinet product code.

File drawers include file bars for front to back and side to side filing. File drawers do not support bottom loading.

Random locks are factory installed.

Keylike are field installed using the KnollKey order form.

Each locking pedestal on this page counts for one lock core.

Each pedestal may require 3 counterweights when used in unsecured fashion. (ie. Freestanding)

1 counterweight = 10 lbs.

Applicable finishes are listed on page 5 and 6.

Product on this page excluding J-pull option will accept woodgrain laminate where laminate is currently an option.

List price for woodgrain laminate options will be current published laminate list price plus 10%.

# Pedestals, 26 1/2" planning

## BBF/FF

### Wood interiors and wood backs

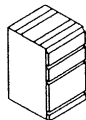
description	w	d	h	pattern no.	wood interiors L	wood interiors V1	wood interiors V2	wood interiors V3
 Pedestal with box box file configuration	16"	20"	26 1/2"	<b>RPB211J</b> ( ) ( ) <b>L</b>	\$1,330.	\$1,420.	\$1,632.	\$2,197.
	16"	24"	26 1/2"	<b>RPB212J</b> ( ) ( ) <b>L</b>	1,459.	1,564.	1,799.	2,422.
	16"	30"	26 1/2"	<b>RPB213J</b> ( ) ( ) <b>L</b>	1,578.	1,688.	1,939.	2,611.

\*Pedestals may require counterweights when used in unsecured fashion (i.e. freestanding).  
\*3 counterweights per pedestal.

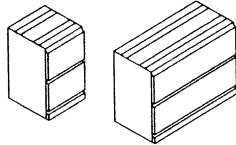
description	w	d	h	pattern no.	wood interiors L	wood interiors V1	wood interiors V2	wood interiors V3
 Pedestal with file file configuration	16"	20"	26 1/2"	<b>RPB211K</b> ( ) ( ) <b>L</b>	1,224.	1,312.	1,510.	2,039.
	16"	24"	26 1/2"	<b>RPB212K</b> ( ) ( ) <b>L</b>	1,421.	1,523.	1,754.	2,368.
	16"	30"	26 1/2"	<b>RPB213K</b> ( ) ( ) <b>L</b>	1,541.	1,651.	1,902.	2,566.
	30"	20"	26 1/2"	<b>RPB231K</b> ( ) ( ) <b>L</b>	1,674.	1,795.	2,063.	2,786.
	30"	24"	26 1/2"	<b>RPB232K</b> ( ) ( ) <b>L</b>	1,865.	2,062.	2,364.	3,192.
	36"	20"	26 1/2"	<b>RPB261K</b> ( ) ( ) <b>L</b>	2,058.	2,205.	2,535.	3,424.
	36"	24"	26 1/2"	<b>RPB262K</b> ( ) ( ) <b>L</b>	2,349.	2,519.	2,895.	3,909.

\*Pedestals may require counterweights when used in unsecured fashion (i.e. freestanding).  
\*3 counterweights per pedestal.

Order Code	Specification Information	Application Notes
Example: <b>RPB211JLWDL</b>	<i>To order please specify pattern number including:</i>	<i>3. Pull options:</i>
<b>R</b> Reff	1. Finish type	D = Metal D-pull
<b>PB</b> Pedestal with back	2. Interior option	J = Routed pull
<b>2</b> 26 1/2"H	3. Pull option	C = Nickel C-pull (nickel finish only)
<b>1</b> 16" wide	4. Lock option, applicable hinged doors only	S = S-pull (stainless steel finish only)
<b>1</b> 20" deep	5. Cabinet finish	F = Bar pull
<b>J</b> Box box file config.	6. Pull finish	H = Outline pull
<b>L</b> Laminate finish	Painted or Plated	R = Cylinder pull
<b>W</b> Wood interior	<b>*After specifying product code, provide keying instructions.</b>	<i>4. Lock options:</i>
<b>D</b> Metal D-pull	<i>1. Finish type:</i>	Pedestals with drawers always lock drilled
<b>L</b> Lock option	L = Laminate	L = Drilled to accept lock
<b>114</b> Cabinet finish	1 = V1	Lock default is Black
<b>612</b> Pull finish	2 = V2	<i>5. Refer to page 523 for keying instructions.</i>
	3 = V3	
	<i>2. Interior options:</i>	Each pedestal with wood drawers includes one pencil tray and two tray dividers in top box drawer. Metal drawer pedestals have one pencil tray.
	W = Wood (shelves match case finish: L, V1, V2 or V3; drawer interiors cherry veneer)	Pedestals must be ordered with back panel to achieve full depth without a modesty panel.
		<b>Pedestals do not come with lock included. Keying instructions must accompany all cabinet orders.</b>
		Hinge door cabinets have optional lock drilling which can be specified in the cabinet product code.
		File drawers include file bars for front to back and side to side filing. File drawers do not support bottom loading.
		Random locks are factory installed.
		Keylike are field installed using the KnollKey order form.
		Each locking pedestal on this page counts for one lock core.
		Each pedestal may require 3 counterweights when used in unsecured fashion. (ie. Freestanding)

Applicable finishes are listed on page 5 and 6.

# Pedestals, 26 1/2" planning

## BBF/FF

### Wood interiors legal width

description	w	d	h	pattern no.	wood	wood	wood	wood
					interiors	interiors	interiors	interiors
					L	V1	V2	V3
Pedestal with box box file configuration	19"	19"	26 1/2"	RP221J( ) ( ) ( )	\$1,258.	\$1,344.	\$1,545.	\$2,078.
	19"	23"	26 1/2"	RP222J( ) ( ) ( )	1,398.	1,498.	1,718.	2,313.
	19"	29"	26 1/2"	RP223J( ) ( ) ( )	1,520.	1,629.	1,871.	2,517.

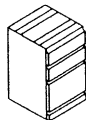

\*Pedestals may require counterweights when used in unsecured fashion (i.e. freestanding).  
\*3 counterweights per pedestal.

description	w	d	h	pattern no.	wood	wood	wood	wood
					interiors	interiors	interiors	interiors
					L	V1	V2	V3
Pedestal with file file configuration	19"	19"	26 1/2"	RP221K( ) ( ) ( )	1,152.	1,235.	1,418.	1,915.
	19"	23"	26 1/2"	RP222K( ) ( ) ( )	1,359.	1,457.	1,671.	2,256.
	19"	29"	26 1/2"	RP223K( ) ( ) ( )	1,482.	1,590.	1,828.	2,467.

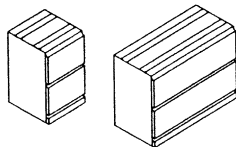

\*Pedestals may require counterweights when used in unsecured fashion (i.e. freestanding).  
\*3 counterweights per pedestal.

Order Code	Specification Information	Application Notes
Example: <b>RP221JLWDL</b>	<i>To order please specify pattern number including:</i>	<i>3. Pull options:</i>
<b>R</b> Reff	1. Finish type	D = Metal D-pull
<b>P</b> Pedestal	2. Interior option	J = Routed pull
<b>2</b> 26 1/2"H	3. Pull option	C = Nickel C-pull (nickel finish only)
<b>2</b> 19" wide	4. Lock option, files	S = S-pull (stainless steel finish only)
<b>1</b> 19" deep	5. Keying instructions	F = Bar pull
<b>J</b> Box box file config.	6. Cabinet finish	H = Outline pull
<b>L</b> Laminate finish	7. Pull finish	R = Cylinder pull
<b>W</b> Wood interior	Painted or Plated	T = Tab pull
<b>D</b> Metal D-pull	<b>*After specifying product code, provide keying instructions.</b>	<i>4. Lock options:</i>
<b>L</b> Lock option	1. <i>Finish type:</i>	Pedestals with drawers always lock drilled.
<b>114</b> Cabinet finish, Folkstone grey	L = Laminate	L = Drilled to accept lock
<b>612</b> Pull finish	1 = V1	Lock default is Black
	2 = V2	<i>5. Cabinet finish</i>
	3 = V3	<i>6. Pull finish</i>
	<i>2. Interior options:</i>	<i>7. Refer to page 523 for keying instructions.</i>
	W = Wood (shelves match case finish: L, V1, V2 or V3; drawer interiors cherry veneer)	Each pedestal with wood drawers includes one pencil tray and two tray dividers in top box drawer.

**Pedestals do not come with lock included. Keying instructions must accompany all cabinet orders.**

File drawers include file bars for front to back and side to side filing. File drawers do not support bottom loading.

Random locks are factory installed.

Keyalike are field installed using the KnollKey order form.

Each locking pedestal on this page counts for one lock core.

Each pedestal may require 3 counterweights when used in unsecured fashion. (ie. Freestanding)

1 counterweight = 10 lbs.

Applicable finishes are listed on page 5 and 6.

Product on this page excluding J-pull option will accept woodgrain laminate where laminate is currently an option.

List price for woodgrain laminate options will be current published laminate list price plus 10%.

# Pedestals, 26 1/2" planning

## Open / Hinge Door

### Metal interiors

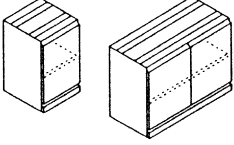
description	w	d	h	pattern no.	metal interiors L	metal interiors V1	metal interiors V2	metal interiors V3
Pedestal with hinge door configuration, includes one shelf 	16"	19"	26 1/2"	<b>RP211L(L/R)-( ) ( ) ( )</b>	\$909.	\$973.	\$1,120.	\$1,511.
	16"	23"	26 1/2"	<b>RP212L(L/R)-( ) ( ) ( )</b>	1,105.	1,182.	1,361.	1,837.
	16"	29"	26 1/2"	<b>RP213L(L/R)-( ) ( ) ( )</b>	1,263.	1,354.	1,558.	2,103.
	30"	19"	26 1/2"	<b>RP231L-( ) ( ) ( )</b>	1,175.	1,258.	1,446.	1,953.
	30"	23"	26 1/2"	<b>RP232L-( ) ( ) ( )</b>	1,372.	1,472.	1,692.	2,284.
	36"	19"	26 1/2"	<b>RP261L-( ) ( ) ( )</b>	1,489.	1,595.	1,836.	2,479.
	36"	23"	26 1/2"	<b>RP262L-( ) ( ) ( )</b>	1,740.	1,865.	2,145.	2,897.

\*Pencil tray not included  
 \*Inside height clearance top shelf 10", bottom shelf 10.5" when shelf located in center position.  
 Metal interior means shelf is metal

description	w	d	h	pattern no.	metal interiors L	metal interiors V1	metal interiors V2	metal interiors V3
Pedestal with open configuration including shelf 	16"	19"	26 1/2"	<b>RP211M-( ) ( ) ( )</b>	692.	743.	852.	1,150.
	16"	23"	26 1/2"	<b>RP212M-( ) ( ) ( )</b>	804.	865.	994.	1,342.
	16"	29"	26 1/2"	<b>RP213M-( ) ( ) ( )</b>	952.	1,020.	1,175.	1,587.
	30"	19"	26 1/2"	<b>RP231M-( ) ( ) ( )</b>	802.	863.	991.	1,338.
	30"	23"	26 1/2"	<b>RP232M-( ) ( ) ( )</b>	977.	1,049.	1,204.	1,626.
	36"	19"	26 1/2"	<b>RP261M-( ) ( ) ( )</b>	1,026.	1,103.	1,268.	1,712.
	36"	23"	26 1/2"	<b>RP262M-( ) ( ) ( )</b>	1,243.	1,333.	1,532.	2,067.

\*Pencil tray not included  
 \*Inside height clearance top shelf 10", bottom shelf 10.5" when shelf located in center position.  
 Metal interior means metal shelf.

Order Code	Specification Information	Application Notes
Example: <b>RP211LLMDL</b> <b>R</b> Reff <b>P</b> Pedestal <b>2</b> 26 1/2"H <b>1</b> 16" wide <b>1</b> 19" deep <b>L</b> Hinge door config. <b>L</b> Laminate finish <b>M</b> Metal interior <b>D</b> Metal D-pull <b>L</b> Lock option <b>114</b> Cabinet Finish <b>612</b> Pull Finish	To order please specify pattern number including: 1. Hinge location, where applicable 2. Finish type 3. Interior option 4. Pull option 5. Lock option, applicable hinged doors only 6. Cabinet finish 7. Pull Finish Painted or Plated  <b>*After specifying product code, provide keying instructions.</b> 1. Hinge location: L = Left hand R = Right hand  2. Finish type: L = Laminate 1 = V1 2 = V2 3 = V3  3. Interior options: M = Metal (If laminate case finish-shelves painted to match; if V1,V2 or V3 case finish-shelves painted black; drawer interiors painted black metal)	4. Pull options: D = Metal D-pull J = Routed pull C = Nickel C-pull (nickel finish only) S = S-pull (stainless steel finish only) F = Bar pull H = Outline pull R = Cylinder pull T = Tab pull  5. Lock options: L = Drilled to accept lock N = No drilling Lock default is Black  6. Refer to page 523 for keying instructions.  Pencil tray to be ordered separately; see page 425.  Pedestals must be ordered with back panel to achieve full depth without a modesty panel.

**Pedestals do not come with lock included. Keying instructions must accompany all cabinet orders.**

Hinge door cabinets have optional lock drilling which can be specified in the cabinet product code.

Random locks are factory installed.

Keyalike are field installed using the KnollKey order form.

Each locking pedestal on this page counts for one lock core.

For Open Pedestals;  
 1. Finish type  
 2. Interior Option  
 3. Cabinet Finish

Applicable finishes are listed on page 5 and 6.

Product on this page excluding J-pull option will accept woodgrain laminate where laminate is currently an option.

List price for woodgrain laminate options will be current published laminate list price plus 10%.

Pedestals, 26 1/2" planning  
 Open / Hinge Door  
 Metal interiors and wood backs

Reff Profiles

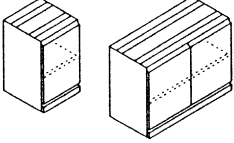
description	w	d	h	pattern no.	metal interiors L	metal interiors V1	metal interiors V2	metal interiors V3
Pedestal with hinge door configuration, includes one shelf 	16"	20"	26 1/2"	<b>RPB211L(L/R)( ) ( ) ( )</b>	\$1,038.	\$1,110.	\$1,281.	\$1,730.
	16"	24"	26 1/2"	<b>RPB212L(L/R)( ) ( ) ( )</b>	1,235.	1,321.	1,520.	2,051.
	16"	30"	26 1/2"	<b>RPB213L(L/R)( ) ( ) ( )</b>	1,392.	1,491.	1,718.	2,321.
	30"	20"	26 1/2"	<b>RPB231L( ) ( ) ( )</b>	1,431.	1,532.	1,760.	2,376.
	30"	24"	26 1/2"	<b>RPB232L( ) ( ) ( )</b>	1,629.	1,745.	2,005.	2,706.
	36"	20"	26 1/2"	<b>RPB261L( ) ( ) ( )</b>	1,790.	1,919.	2,207.	2,980.
	36"	24"	26 1/2"	<b>RPB262L( ) ( ) ( )</b>	2,042.	2,190.	2,519.	3,400.

\*Pencil Tray not included  
 Inside height clearance top shelf 10", bottom shelf 10.5" when shelf located in center position.  
 Metal interior means shelf metal.

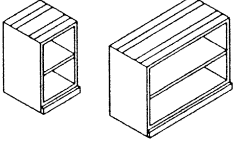
description	w	d	h	pattern no.	metal interiors L	metal interiors V1	metal interiors V2	metal interiors V3
Pedestal with open configuration including shelf 	16"	20"	26 1/2"	<b>RPB211M( ) ( ) ( )</b>	821.	876.	1,012.	1,367.
	16"	24"	26 1/2"	<b>RPB212M( ) ( ) ( )</b>	938.	1,001.	1,155.	1,559.
	16"	30"	26 1/2"	<b>RPB213M( ) ( ) ( )</b>	1,080.	1,158.	1,333.	1,800.
	30"	20"	26 1/2"	<b>RPB231M( ) ( ) ( )</b>	1,060.	1,137.	1,306.	1,763.
	30"	24"	26 1/2"	<b>RPB232M( ) ( ) ( )</b>	1,233.	1,321.	1,515.	2,046.
	36"	20"	26 1/2"	<b>RPB261M( ) ( ) ( )</b>	1,333.	1,426.	1,641.	2,215.
	36"	24"	26 1/2"	<b>RPB262M( ) ( ) ( )</b>	1,546.	1,658.	1,905.	2,571.

\*Pencil Tray not included  
 Inside height clearance top shelf 10", bottom shelf 10.5" when shelf located in center position.  
 Metal interior means shelf metal.

Order Code	Specification Information	Application Notes
Example: <b>RPB211LL</b>	<i>To order please specify pattern number including:</i>	<i>4. Pull options:</i>
<b>R</b> Reff	1. Hinge location, where applicable	D = Metal D-pull
<b>PB</b> Pedestal with back	2. Finish type	J = Routed pull
<b>2</b> 26 1/2"H	3. Interior option	C = Nickel C-pull (nickel finish only)
<b>1</b> 16" wide	4. Pull option	S = S-pull (stainless steel finish only)
<b>1</b> 20" deep	5. Lock option, applicable hinged doors only	F = Bar pull
<b>L</b> Hinge door	6. Cabinet finish	H = Outline pull
<b>L</b> Hinge Left	7. Pull finish	R = Cylinder pull
<b>L</b> Laminate finish	<b>*After specifying product code, provide keying instructions.</b>	T = Tab pull
<b>M</b> Metal interior	<i>1. Hinge location:</i>	<i>5. Lock options:</i>
<b>D</b> Metal D-pull	L = Left hand	Optional hinge door configuration only.
<b>L</b> Lock option	R = Right hand	L = Drilled to accept lock
<b>118</b> Cabinet finish	<i>2. Finish type:</i>	N = No drilling
<b>118</b> Pull finish	L = Laminate	Lock default is Black
	1 = V1	<i>6. Refer to page 523 for keying instructions.</i>
	2 = V2	Pedestals must be ordered with back panel to achieve full depth without a modesty panel.
	3 = V3	
	<i>3. Interior options:</i>	
	M = Metal (If laminate case finish-shelves painted to match; if V1, V2 or V3 case finish-shelves painted black; drawer interiors painted black metal)	

**Pedestals do not come with lock included. Keying instructions must accompany all cabinet orders.**

Hinge door cabinets have optional lock drilling which can be specified in the cabinet product code.

Random locks are factory installed.

Keyalike are field installed using the KnollKey order form.

Each locking pedestal on this page counts for one lock core.

For Open Pedestals;  
 1. Finish type  
 2. Interior Option  
 3. Cabinet Finish

Applicable finishes are listed on page 5 and 6.

# Pedestals, 26 1/2" planning

## Open / Hinge Door

### Wood interior

Reff Profiles

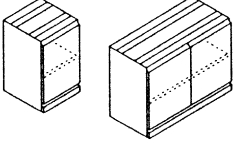
description	w	d	h	pattern no.	wood interiors L	wood interiors V1	wood interiors V2	wood interiors V3
Pedestal with hinge door configuration, includes one shelf 	16"	19"	26 1/2"	RP211L(L/R)-( ) ( ) ( )	\$994.	\$1,064.	\$1,227.	\$1,659.
	16"	23"	26 1/2"	RP212L(L/R)-( ) ( ) ( )	1,194.	1,281.	1,471.	1,986.
	16"	29"	26 1/2"	RP213L(L/R)-( ) ( ) ( )	1,351.	1,448.	1,664.	2,247.
	30"	19"	26 1/2"	RP231L-( ) ( ) ( )	1,260.	1,350.	1,556.	2,100.
	30"	23"	26 1/2"	RP232L-( ) ( ) ( )	1,460.	1,569.	1,804.	2,434.
	36"	19"	26 1/2"	RP261L-( ) ( ) ( )	1,576.	1,688.	1,942.	2,621.
	36"	23"	26 1/2"	RP262L-( ) ( ) ( )	1,828.	1,959.	2,252.	3,040.

Inside height clearance top shelf 10", bottom shelf 10.5" when shelf located in center position  
N=No Lock option

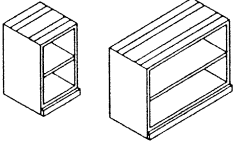
description	w	d	h	pattern no.	wood interiors L	wood interiors V1	wood interiors V2	wood interiors V3
Pedestal with open configuration including shelf 	16"	19"	26 1/2"	RP211M-( ) ( ) ( )	778.	832.	957.	1,290.
	16"	23"	26 1/2"	RP212M-( ) ( ) ( )	896.	961.	1,106.	1,491.
	16"	29"	26 1/2"	RP213M-( ) ( ) ( )	1,041.	1,114.	1,283.	1,733.
	30"	19"	26 1/2"	RP231M-( ) ( ) ( )	894.	956.	1,098.	1,483.
	30"	23"	26 1/2"	RP232M-( ) ( ) ( )	1,063.	1,140.	1,312.	1,769.
	36"	19"	26 1/2"	RP261M-( ) ( ) ( )	1,114.	1,197.	1,378.	1,859.
	36"	23"	26 1/2"	RP262M-( ) ( ) ( )	1,332.	1,423.	1,638.	2,211.

Inside height clearance top shelf 10", bottom shelf 10.5" when shelf located in center position.

Order Code	Specification Information	Application Notes
Example: <b>RP211LLWDL</b>	<i>To order please specify pattern number including:</i>	<b>4. Pull options:</b>
<b>R</b> Reff	1. Hinge location, where applicable	D = Metal D-pull
<b>P</b> Pedestal	2. Finish type	J = Routed pull
<b>2</b> 26 1/2"H	3. Interior option	C = Nickel C-pull (nickel finish only)
<b>1</b> 16" wide	4. Pull option	S = S-pull (stainless steel finish only)
<b>1</b> 19" deep	5. Lock option, applicable hinged doors only	F = Bar pull
<b>L</b> Hinge door	6. Cabinet finish	H = Outline pull
<b>L</b> Laminate finish	7. Pull finish	T = Tab pull
<b>W</b> Wood interior	<b>*After specifying product code, provide keying instructions.</b>	R = Cylinder pull
<b>D</b> Metal D-pull	<b>1. Hinge location:</b>	<b>5. Lock options:</b>
<b>L</b> Lock hole drilled	L = Left hand	Optional hinge door configuration only.
<b>118</b> Cabinet finish	R = Right hand	L = Drilled to accept lock
<b>118</b> Pull finish	<b>2. Finish type:</b>	N = No drilling
	L = Laminate	Lock default is Black
	1 = V1	<b>6. Refer to page 523 for keying instructions.</b>
	2 = V2	
	3 = V3	
	<b>3. Interior options:</b>	Each pedestal with wood drawers includes one pencil tray and two tray dividers in top box drawer.
	W = Wood (shelves match case finish: L, V1, V2 or V3; drawer interiors cherry veneer)	Pedestals must be ordered with back panel to achieve full depth without a modesty panel.

Applicable finishes are listed on page 5 and 6.

Product on this page excluding J-pull option will accept woodgrain laminate where laminate is currently an option. List price for woodgrain laminate options will be current published laminate list price plus 10%.

Pedestals, 26 1/2" planning  
 Open / Hinge Door  
 Wood interiors and wood backs

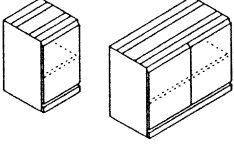
description	w	d	h	pattern no.	wood interiors L	wood interiors V1	wood interiors V2	wood interiors V3
Pedestal with hinge door configuration, includes one shelf 	16"	20"	26 1/2"	<b>RPB211L(L/R)</b> ( ) ( ) ( )	\$1,124.	\$1,204.	\$1,387.	\$1,872.
	16"	24"	26 1/2"	<b>RPB212L(L/R)</b> ( ) ( ) ( )	1,321.	1,415.	1,630.	2,200.
	16"	30"	26 1/2"	<b>RPB213L(L/R)</b> ( ) ( ) ( )	1,480.	1,584.	1,822.	2,460.
	30"	20"	26 1/2"	<b>RPB231L</b> ( ) ( ) ( )	1,515.	1,623.	1,870.	2,525.
	30"	24"	26 1/2"	<b>RPB232L</b> ( ) ( ) ( )	1,715.	1,840.	2,114.	2,854.
	36"	20"	26 1/2"	<b>RPB261L</b> ( ) ( ) ( )	1,879.	2,013.	2,312.	3,122.
	36"	24"	26 1/2"	<b>RPB262L</b> ( ) ( ) ( )	2,132.	2,283.	2,626.	3,545.

Inside height clearance top shelf 10", bottom shelf 10.5" when shelf located in center position.

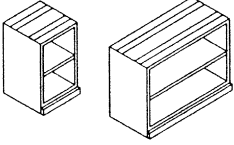
description	w	d	h	pattern no.	wood interiors L	wood interiors V1	wood interiors V2	wood interiors V3
Pedestal with open configuration including shelf 	16"	20"	26 1/2"	<b>RPB211M</b> ( ) ( ) ( )	907.	970.	1,119.	1,510.
	16"	24"	26 1/2"	<b>RPB212M</b> ( ) ( ) ( )	1,023.	1,097.	1,264.	1,706.
	16"	30"	26 1/2"	<b>RPB213M</b> ( ) ( ) ( )	1,169.	1,249.	1,441.	1,946.
	30"	20"	26 1/2"	<b>RPB231M</b> ( ) ( ) ( )	1,147.	1,229.	1,411.	1,906.
	30"	24"	26 1/2"	<b>RPB232M</b> ( ) ( ) ( )	1,320.	1,414.	1,623.	2,190.
	36"	20"	26 1/2"	<b>RPB261M</b> ( ) ( ) ( )	1,418.	1,522.	1,748.	2,359.
	36"	24"	26 1/2"	<b>RPB262M</b> ( ) ( ) ( )	1,633.	1,748.	2,010.	2,712.

Inside height clearance top shelf 10", bottom shelf 10.5" when shelf located in center position.

**Order Code**

Example:	<b>RPB211LLWDL</b>
<b>R</b>	Reff
<b>PB</b>	Pedestal with back
<b>2</b>	26 1/2"H
<b>1</b>	16" wide
<b>1</b>	20" deep
<b>L</b>	Hinged door
<b>L</b>	Laminate finish
<b>W</b>	Wood interior
<b>D</b>	Metal D-pull
<b>L</b>	Lock option
<b>118</b>	Cabinet finish
<b>118</b>	Pull finish

Applicable finishes are listed on page 5 and 6.

**Specification Information**

*To order please specify pattern number including:*

- Hinge location, where applicable
- Finish type
- Interior option
- Pull option
- Lock option, applicable hinged doors only
- Cabinet finish
- Pull finish  
Painted or Plated

**\*After specifying product code, provide keying instructions.**

- Hinge location:*  
L = Left hand  
R = Right hand
- Finish type:*  
L = Laminate  
1 = V1  
2 = V2  
3 = V3
- Interior options:*  
W = Wood (shelves match case finish: L, V1, V2 or V3; drawer interiors cherry veneer)

**Application Notes**

- Pull options:*  
D = Metal D-pull  
J = Routed pull  
C = Nickel C-pull (nickel finish only)  
S = S-pull (stainless steel finish only)  
F = Bar pull  
H = Outline pull  
T = Tab pull  
R = Cylinder pull
- Lock options:*  
Optional hinge door configuration  
L = Drilled to accept lock  
N = No drilling  
Lock default is Black
- Refer to page 523 for keying instructions.  
Pedestals must be ordered with back panels to achieve full depth without a modesty panel.

**Pedestals do not come with lock included. Keying instructions must accompany all cabinet orders.**

Hinge door cabinets have optional lock drilling which can be specified in the cabinet product code.

Random locks are factory installed.

Keyalike are field installed using the KnollKey order form.

Each locking pedestal on this page counts for one lock core.



# Pedestals, 26 1/2" planning

## Mobile Pedestal

### Metal interiors

description	w	d	h	pattern no.	metal interiors L	metal interiors V1	metal interiors V2	metal interiors V3	list
Mobile pedestal with box/file, box/box/file and file/file configuration (5 wheels)	16"	19"	21"	<b>RM111J-()()L</b>	\$1,111.	\$1,190.	\$1,368.	\$1,847.	
	16"	23"	21"	<b>RM112J-()()L</b>	1,161.	1,245.	1,433.	1,934.	
	16"	23"	26 1/2"	<b>RM212J-()()L</b>	1,559.	1,673.	1,921.	2,595.	
	16"	23"	26 1/2"	<b>RM212K-()()L</b>	1,559.	1,673.	1,921.	2,595.	



\*Pencil tray not included  
\*Glue and dowel construction

Pedestal backs	w	d	h	pattern no.	metal interiors L	metal interiors V1	metal interiors V2	metal interiors V3	list
Pedestal backs	16"	1"	26 1/2"	<b>RPAB16-()</b>	119.	123.	143.	193.	
	19"	1"	26 1/2"	<b>RPAB19-()</b>	125.	129.	150.	204.	
	30"	1"	26 1/2"	<b>RPAB30-()</b>	238.	244.	279.	377.	
	36"	1"	26 1/2"	<b>RPAB36-()</b>	280.	290.	333.	450.	

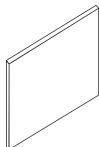

\*Pencil tray not included  
\*Pedestal backs for pedestals with metal or wood interiors.

Counter weight (for file/file configuration pedestals when used in freestanding applications)	-	-	-	<b>RCOUNTWT</b>					97.
-----------------------------------------------------------------------------------------------	---	---	---	-----------------	--	--	--	--	-----

Cabinetry

Order Code	Specification Information	Application Notes
Example: <b>RM111J</b>	<i>To order please specify pattern number including:</i>	<i>3. Pull options:</i>
<b>R</b> Reff	1. Finish type	D = Metal D-pull
<b>M</b> Mobile Pedestal	2. Interior option	J = Routed pull
<b>1</b> 21"H	3. Pull option	C = Nickel C-pull (nickel finish only)
<b>1</b> 16" wide	4. Lock option, files	S = S-pull (stainless steel finish only)
<b>1</b> 19" deep	5. Cabinet Finish	F = Bar pull
<b>J</b> Box box file config.	6. Pull Finish	H = Outline pull
<b>L</b> Laminate finish	Painted or Plated	R = Cylinder pull
<b>M</b> Metal interior	<b>*After specifying product code, provide keying instructions.</b>	T = Tab pull
<b>D</b> Metal D-pull	<i>1. Finish type:</i>	<i>4. Lock options:</i>
<b>L</b> Lock option	L = Laminate	L = Drilled to accept lock
<b>114</b> Cabinet Finish	1 = V1	
<b>612</b> Pull Finish	2 = V2	<i>5. Refer to page 523 for keying instructions.</i>
	3 = V3	Pencil tray to be ordered separately; see page 425.

Applicable finishes are listed on page 5 and 6.

Product on this page excluding J-pull option will accept woodgrain laminate where laminate is currently an option.

List price for woodgrain laminate options will be current published laminate list price plus 10%.

*2. Interior options:*  
M = Metal (If laminate case finish-shelves painted to match; if V1,V2 or V3 case finish-shelves painted black; drawer interiors painted black metal)

Pedestals must be ordered with back panel to achieve full depth without a modesty panel.

**Pedestals do not come with lock included. Keying instructions must accompany all cabinet orders.**

Mobile pedestals are always equipped with finished backs.

File drawers include file bars for front to back and side to side filing. File drawers do not support bottom loading.

Random locks are factory installed.

Keyalike are field installed using the KnollKey order form.

Each locking pedestal on this page counts for one lock core.

Mobile pedestals are glue and dowel construction.

# Pedestals, 26 1/2" planning

## Mobile Pedestal

### Wood interiors

description	w	d	h	pattern no.	wood interiors L	wood interiors V1	wood interiors V2	wood interiors V3	list
Mobile pedestal with box/file, box/box/file and file/file configuration (5 wheels)	16"	19"	21"	<b>RM111J-()()L</b>	\$1,314.	\$1,410.	\$1,622.	\$2,189.	
	16"	23"	21"	<b>RM112J-()()L</b>	1,387.	1,486.	1,709.	2,307.	
	16"	23"	26 1/2"	<b>RM212K-()()L</b>	1,877.	2,011.	2,312.	3,122.	
	16"	23"	26 1/2"	<b>RM212J-()()L</b>	1,877.	2,011.	2,312.	3,122.	



Glue and dowel construction

Pedestal backs	w	d	h	pattern no.	wood interiors L	wood interiors V1	wood interiors V2	wood interiors V3	list
	16"	1"	26 1/2"	<b>RPAB16-()</b>	119.	123.	143.	193.	
	19"	1"	26 1/2"	<b>RPAB19-()</b>	125.	129.	150.	204.	
	30"	1"	26 1/2"	<b>RPAB30-()</b>	238.	244.	279.	377.	
	36"	1"	26 1/2"	<b>RPAB36-()</b>	280.	290.	333.	450.	

pedestal backs for pedestals with metal or wood interiors.

Counter weight (for file/file configuration pedestals when used in freestanding applications)	-	-	-	<b>RCOUNTWT</b>					97.
-----------------------------------------------------------------------------------------------	---	---	---	-----------------	--	--	--	--	-----

Order Code	Specification Information	Application Notes
Example: <b>RM111J</b>	<i>To order please specify pattern number including:</i>	<i>3. Pull options:</i>
<b>R</b> Reff	1. Finish type	D = Metal D-pull
<b>M</b> Mobile Pedestal	2. Interior option	J = Routed pull
<b>1</b> 21"H	3. Pull option	C = Nickel C-pull (nickel finish only)
<b>1</b> 16" wide	4. Lock option, files	S = S-pull (stainless steel finish only)
<b>1</b> 19" deep	5. Cabinet Finish	F = Bar pull
<b>J</b> Box box file config.	6. Pull Finish	H = Outline pull
<b>L</b> Laminate finish	Painted or Plated	R = Cylinder pull
<b>W</b> Wood interior		T = Tab pull
<b>D</b> Metal D-pull		
<b>L</b> Lock option		
<b>114</b> Cabinet Finish		
<b>612</b> Pull Finish		

**After specifying product code, provide keying instructions.**

*1. Finish type:*  
L = Laminate  
1 = V1  
2 = V2  
3 = V3

*2. Interior options:*  
M = Metal (If laminate case finish-shelves painted to match; if V1,V2 or V3 case finish-shelves painted black; drawer interiors painted black metal)

*3. Pull options:*  
D = Metal D-pull  
J = Routed pull  
C = Nickel C-pull (nickel finish only)  
S = S-pull (stainless steel finish only)  
F = Bar pull  
H = Outline pull  
R = Cylinder pull  
T = Tab pull

*4. Lock options:*  
L = Drilled to accept lock

*5. Refer to page 523 for keying instructions.*

Pencil tray to be ordered separately; see page 425.

Pedestals must be ordered with back panel to achieve full depth without a modesty panel.

**Pedestals do not come with lock included. Keying instructions must accompany all cabinet orders.**

Mobile pedestals are always equipped with finished backs.

File drawers include file bars for front to back and side to side filing. File drawers do not support bottom loading.

Random locks are factory installed.

Keyalike are field installed using the KnollKey order form.

Each locking pedestal on this page counts for one lock core.

Mobile pedestals are glue and dowel construction.

Applicable finishes are listed on page 5 and 6.

Product on this page excluding J-pull option will accept woodgrain laminate where laminate is currently an option.

List price for woodgrain laminate options will be current published laminate list price plus 10%.

# Pedestals, 28<sup>3</sup>/<sub>8</sub>" planning

## BBF/FF

### Metal interiors

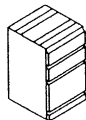
description	w	d	h	pattern no.	metal interiors L	metal interiors V1	metal interiors V2	metal interiors V3
 Pedestal, (desk height) box/box/file configuration	16"	19"	28 <sup>3</sup> / <sub>8</sub> "	RP161J ( ) ( ) L ( )	\$1,184.	\$1,267.	\$1,457.	\$1,961.
	16"	23"	28 <sup>3</sup> / <sub>8</sub> "	RP162J ( ) ( ) L ( )	1,239.	1,328.	1,526.	2,053.
	16"	29"	28 <sup>3</sup> / <sub>8</sub> "	RP163J ( ) ( ) L ( )	1,291.	1,383.	1,590.	2,139.

\*Pencil Tray not included

Pedestals may require counterweights when used in unsecured fashion (ie freestanding)

\*3 counterweights per pedestal

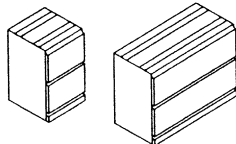
description	w	d	h	pattern no.	metal interiors L	metal interiors V1	metal interiors V2	metal interiors V3
 Pedestal, (desk height) file/file configuration	16"	19"	28 <sup>3</sup> / <sub>8</sub> "	RP161K ( ) ( ) L ( )	1,087.	1,166.	1,341.	1,812.
	16"	23"	28 <sup>3</sup> / <sub>8</sub> "	RP162K ( ) ( ) L ( )	1,164.	1,247.	1,437.	1,941.
	16"	29"	28 <sup>3</sup> / <sub>8</sub> "	RP163K ( ) ( ) L ( )	1,242.	1,328.	1,530.	2,064.
	30"	19"	28 <sup>3</sup> / <sub>8</sub> "	RP301K ( ) ( ) L ( )	1,244.	1,335.	1,533.	2,068.
	30"	23"	28 <sup>3</sup> / <sub>8</sub> "	RP302K ( ) ( ) L ( )	1,312.	1,406.	1,615.	2,181.
	36"	19"	28 <sup>3</sup> / <sub>8</sub> "	RP361K ( ) ( ) L ( )	1,324.	1,423.	1,636.	2,210.
	36"	23"	28 <sup>3</sup> / <sub>8</sub> "	RP362K ( ) ( ) L ( )	1,392.	1,490.	1,715.	2,316.

\*Pencil Tray not included

Pedestals may require counterweights when used in unsecured fashion (ie freestanding)

\*3 counterweights per pedestal

Order Code	Specification Information
Example: <b>RP161J(L)(M)(J)L(118)</b>	
<b>R</b>	Reff
<b>P</b>	Pedestal
<b>16</b>	16" wide (nominal)
<b>1</b>	19" deep (nominal)
<b>J</b>	Box/Box/File config.
<b>L</b>	Finish type, laminate
<b>M</b>	Interior option, metal
<b>J</b>	Pull option, J
<b>L</b>	Lock option
<b>118</b>	Cabinet finish
<b>118</b>	Pull finish

Specification Information
To order please specify pattern number including:
1. <i>Finish type</i> L = laminate 1 = V1 2 = V2 3 = V3
2. <i>Interior option</i> M = metal (If laminate case finish- shelves painted to match; if V1, V2 or V3 case finish-shelves painted black; drawer interiors painted black metal)
3. <i>Pull option</i> D = metal D-pull (finish optional) J = routed J-pull (finish matches case) C = nickel finish C-pull (nickel finish only) S = S-pull (stainless steel finish only) R = Cylinder T = Tab F = Bar H = Out Line

5. *Lock option*  
Lock default is black.  
Pedestals with drawers always lock drilled  
L = drilled to accept lock

6. *Cabinet finish*

7. *Pull finish*  
Painted or Plated

Product on this page excluding J-pull option will accept woodgrain laminate where laminate is currently an option.  
List price for woodgrain laminate options will be current published laminate list price plus 10%.

**Keying instructions must accompany all orders, refer to page 523 . Pedestals do not come with lock included.** Random locks are factory installed. Key-alike are field installed using the KnollKey order form. Each locking pedestal on this page counts for one lock core.

Pencil tray to be ordered separately; see page 425.

Finished back must be ordered separately to achieve full depth without a modesty. (page 272 )

#### Application Notes

**Products on this page are 28-3/8" high.** 28<sup>3</sup>/<sub>8</sub>"h "desk height" products should not be mixed with 26<sup>1</sup>/<sub>2</sub>"h components. 28<sup>3</sup>/<sub>8</sub>"h components when used with 1<sup>1</sup>/<sub>4</sub>" worksurfaces achieve overall desk height of 29<sup>3</sup>/<sub>8</sub>"h. 28-3/8" "desk height" products may be specified for freestanding or panel based applications.

File drawers include file bars for front to back and side to side filing.

File drawers support bottom loading.

Applicable finishes are listed on page 5 and 6.

Each pedestal may require 3 counterweights when used in unsecured fashion. (ie. Freestanding)

1 counterweight = 10 lbs.

# Pedestals, 28<sup>3</sup>/<sub>8</sub>" planning

## BBF/FF

### Metal interior legal width

description	w	d	h	pattern no.	metal interiors L	metal interiors V1	metal interiors V2	metal interiors V3
Pedestal, (desk height)	19"	19"	28 <sup>3</sup> / <sub>8</sub> "	RP191J( ) ( ) ( )	\$1,242.	\$1,330.	\$1,529.	\$2,058.
box/box/file configuration	19"	23"	28 <sup>3</sup> / <sub>8</sub> "	RP192J( ) ( ) ( )	1,301.	1,360.	1,601.	2,155.
	19"	29"	28 <sup>3</sup> / <sub>8</sub> "	RP193J( ) ( ) ( )	1,355.	1,451.	1,668.	2,246.

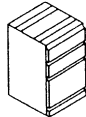

Pencil tray not included

Pedestals may require counterweights when used in unsecured fashion (ie freestanding)

\*3 counterweights per pedestal

Pedestal, (desk height)	19"	19"	28 <sup>3</sup> / <sub>8</sub> "	RP191K( ) ( ) ( )	1,141.	1,224.	1,408.	1,903.
file/file configuration	19"	23"	28 <sup>3</sup> / <sub>8</sub> "	RP192K( ) ( ) ( )	1,222.	1,310.	1,509.	2,038.
	19"	29"	28 <sup>3</sup> / <sub>8</sub> "	RP193K( ) ( ) ( )	1,305.	1,394.	1,606.	2,167.

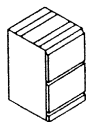

Pencil tray not included

Pedestals may require counterweights when used in unsecured fashion (ie freestanding)

\*3 counterweights per pedestal

Order Code	Specification Information	Application Notes
Example: <b>RP191J(L)(M)(J)L(118)</b>	<i>To order please specify pattern number including:</i>	<p><b>Products on this page are 28-3/8" high.</b> 28<sup>3</sup>/<sub>8</sub>"h "desk height" products should not be mixed with 26<sup>1</sup>/<sub>2</sub>"h components. 28<sup>3</sup>/<sub>8</sub>"h components when used with 1<sup>1</sup>/<sub>4</sub>" worksurfaces achieve overall desk height of 29<sup>3</sup>/<sub>8</sub>"h. 28-3/8" "desk height" products may be specified for freestanding or panel based applications.</p> <p>File drawers include file bars for front to back and side to side filing.</p> <p>File drawers support bottom loading.</p> <p>Applicable finishes are listed on page 5 and 6.</p> <p>Each pedestal may require 3 counterweights when used in unsecured fashion. (ie. Freestanding)</p> <p>1 counterweight = 10 lbs.</p>
<b>R</b> Ref		
<b>P</b> Pedestal		
<b>19</b> 19" wide ( <i>nominal</i> )		
<b>1</b> 19" deep ( <i>nominal</i> )		
<b>J</b> Box/Box/File configuration		
<b>L</b> Finish type, laminate		
<b>M</b> Interior option, metal		
<b>J</b> Pull option, J		
<b>L</b> Lock option		
<b>118</b> Cabinet finish		
<b>118</b> Pull finish		
	<p>1. <i>Finish type</i> L = laminate 1 = V1 2 = V2 3 = V3</p> <p>2. <i>Interior option</i> M = metal (If laminate case finish- shelves painted to match; if V1, V2 or V3 case finish-shelves painted black; drawer interiors painted black metal)</p> <p>3. <i>Pull option</i> D = metal D-pull (finish optional) J = routed J-pull (finish matches case) C = nickel finish C-pull (nickel finish only) S = S-pull (stainless steel finish only) F = Bar pull H = Outline pull R = Cylinder pull T = Tab pull</p> <p>4. <i>Lock option</i> Lock default is Black Pedestals with drawers always lock drilled L = drilled to accept lock</p> <p>5. <i>Cabinet finish</i></p> <p>6. <i>Pull finish</i> Painted or Plated</p> <p>Product on this page excluding J-pull option will accept woodgrain laminate where laminate is currently an option. List price for woodgrain laminate options will be current published laminate list price plus 10%.</p> <p><b>Keying instructions must accompany all orders, refer to page 523 . Pedestals do not come with lock included.</b> Random locks are factory installed. Key-alike are field installed using the KnollKey order form. Each locking pedestal on this page counts for one lock core.</p> <p>Pencil tray to be ordered separately; see page 425.</p> <p>Finished back must be ordered separately to achieve full depth without a modesty. (page279)</p>	

# Pedestals, 28<sup>3</sup>/<sub>8</sub>" planning

## BBF/FF

### Wood interior

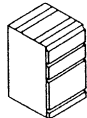
description	w	d	h	pattern no.	wood interiors L	wood interiors V1	wood interiors V2	wood interiors V3
	16"	19"	28 <sup>3</sup> / <sub>8</sub> "	<b>RP161J</b> ( ) ( ) L ( )	\$1,258.	\$1,344.	\$1,543.	\$2,076.
	16"	23"	28 <sup>3</sup> / <sub>8</sub> "	<b>RP162J</b> ( ) ( ) L ( )	1,396.	1,498.	1,720.	2,314.
	16"	29"	28 <sup>3</sup> / <sub>8</sub> "	<b>RP163J</b> ( ) ( ) L ( )	1,519.	1,630.	1,869.	2,515.

Pedestals may require counterweights when used in unsecured fashion (ie freestanding)  
\*3 counterweights per pedestal

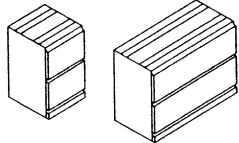
description	w	d	h	pattern no.	wood interiors L	wood interiors V1	wood interiors V2	wood interiors V3
	16"	19"	28 <sup>3</sup> / <sub>8</sub> "	<b>RP161K</b> ( ) ( ) L ( )	1,153.	1,235.	1,419.	1,916.
	16"	23"	28 <sup>3</sup> / <sub>8</sub> "	<b>RP162K</b> ( ) ( ) L ( )	1,358.	1,456.	1,673.	2,258.
	16"	29"	28 <sup>3</sup> / <sub>8</sub> "	<b>RP163K</b> ( ) ( ) L ( )	1,481.	1,590.	1,828.	2,467.
	30"	19"	28 <sup>3</sup> / <sub>8</sub> "	<b>RP301K</b> ( ) ( ) L ( )	1,490.	1,596.	1,837.	2,480.
	30"	23"	28 <sup>3</sup> / <sub>8</sub> "	<b>RP302K</b> ( ) ( ) L ( )	1,750.	1,877.	2,153.	2,906.
	36"	19"	28 <sup>3</sup> / <sub>8</sub> "	<b>RP361K</b> ( ) ( ) L ( )	1,840.	1,971.	2,271.	3,066.
	36"	23"	28 <sup>3</sup> / <sub>8</sub> "	<b>RP362K</b> ( ) ( ) L ( )	2,145.	2,303.	2,647.	3,572.

Pedestals may require counterweights when used in unsecured fashion (ie freestanding)  
\*3 counterweights per pedestal

Cabinetry

Order Code	Specification Information	Application Notes
Example: <b>RP161J(L)(W)(J)L(118)</b> <b>R</b> Reff <b>P</b> Pedestal <b>16</b> 16" wide ( <i>nominal</i> ) <b>1</b> 19" deep ( <i>nominal</i> ) <b>J</b> Box/Box/File configuration <b>L</b> Finish type, laminate <b>W</b> Interior option, wood <b>D</b> Pull option <b>L</b> Lock option <b>118</b> Cabinet finish <b>118</b> Pull finish	To order please specify pattern number including: 1. <i>Finish type</i> L = laminate 1 = V1 2 = V2 3 = V3 2. <i>Interior option</i> W = wood (shelves match case finish: L,V1,V2 or V3; drawer interiors cherry veneer) 3. <i>Pull option</i> D = metal D-pull (finish optional) J = routed J-pull (finish matches case) C = nickel finish C-pull (nickel finish only) S = S-pull (stainless steel finish only) F = Bar pull H = Outline pull T = Tab pull R = Cylinder pull 4. <i>Lock option</i> Pedestals with drawers always lock drilled Lock default is Black L = drilled for lock 5. <i>Cabinet finish</i> 6. <i>Pull finish</i> Painted or Plated Product on this page excluding J-pull option will accept woodgrain laminate where laminate is currently an option. List price for woodgrain laminate options will be current published laminate list price plus 10%. <b>Keying instructions must accompany all orders, refer to page 523 . Pedestals do not come with lock included.</b> Random locks are factory installed. Key-alike are field installed using the KnollKey order form. Each locking pedestal on this page counts for one lock core. Box-box-file configuration pedestals with wood drawers includes pencil tray and two tray dividers in top box drawer. Finished back must be ordered separately to achieve full depth without a modesty.(page279)	<b>Products on this page are 28-3/8" high.</b> 28 <sup>3</sup> / <sub>8</sub> " "desk height" products should not be mixed with 26 <sup>1</sup> / <sub>2</sub> "h components. 28 <sup>3</sup> / <sub>8</sub> "h components when used with 1 <sup>1</sup> / <sub>4</sub> " worksurfaces achieve overall desk height of 29 <sup>7</sup> / <sub>8</sub> "h. 28-3/8" "desk height" products may be specified for freestanding or panel based applications. File drawers include file bars for front to back and side to side filing. File drawers support bottom loading. Applicable finishes are listed on page 5 and 6. Each pedestal may require 3 counterweights when used in unsecured fashion. (ie. Freestanding) 1 counterweight = 10 lbs.

# Pedestals, 28<sup>3</sup>/<sub>8</sub>" planning

## BBF/FF

### Wood interior legal width

description	w	d	h	pattern no.	wood	wood	wood	wood
					interiors	interiors	interiors	interiors
					L	V1	V2	V3
Pedestal, (desk height)	19"	19"	28 <sup>3</sup> / <sub>8</sub> "	RP191J(L)(W)(J)L(118)	\$1,319.	\$1,411.	\$1,619.	\$2,179.
box/box/file configuration	19"	23"	28 <sup>3</sup> / <sub>8</sub> "	RP192J(L)(W)(J)L(118)	1,465.	1,572.	1,805.	2,429.
	19"	29"	28 <sup>3</sup> / <sub>8</sub> "	RP193J(L)(W)(J)L(118)	1,594.	1,710.	1,961.	2,640.

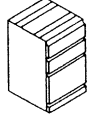

Pedestals may require counterweights when used in unsecured fashion (ie freestanding)  
\*3 counterweights per pedestal

Pedestal, (desk height)	19"	19"	28 <sup>3</sup> / <sub>8</sub> "	RP191K(L)(W)(J)L(118)	1,281.	1,296.	1,490.	2,012.
file/file configuration	19"	23"	28 <sup>3</sup> / <sub>8</sub> "	RP192K(L)(W)(J)L(118)	1,425.	1,529.	1,757.	2,371.
	19"	29"	28 <sup>3</sup> / <sub>8</sub> "	RP193K(L)(W)(J)L(118)	1,555.	1,669.	1,919.	2,590.

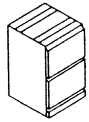

Pedestals may require counterweights when used in unsecured fashion (ie freestanding)  
\*3 counterweights per pedestal

Order Code	Specification Information	Application Notes
Example: <b>RP191J(L)(W)(J)L(118)</b>	<i>To order please specify pattern number including:</i>	
<b>R</b> Reff		
<b>P</b> Pedestal		
<b>19</b> 19" wide ( <i>nominal</i> )		
<b>1</b> 19" deep ( <i>nominal</i> )		
<b>J</b> Box/Box/File configuration		
<b>L</b> Finish type, laminate		
<b>W</b> Interior option, wood		
<b>J</b> Pull option, J		
<b>L</b> Lock option		
<b>118</b> Cabinet finish		
<b>118</b> Pull finish		
	<ol style="list-style-type: none"> <li><i>Finish type</i> L = laminate 1 = V1 2 = V2 3 = V3</li> <li><i>Interior option</i> W = wood (shelves match case finish: L,V1,V2 or V3; drawer interiors cherry veneer)</li> <li><i>Pull option</i> D = metal D-pull (finish optional) J = routed J-pull (finish matches case) C = nickel finish C-pull (nickel finish only) S = S-pull (stainless steel finish only) F = Bar pull H = Outline pull R = Cylinder pull T = Tab pull</li> <li><i>Lock option</i> Pedestals with drawers always lock drilled Lock default is Black L = drilled to accept lock N = no drilling</li> <li><i>Cabinet finish</i></li> <li><i>Pull finish</i> Painted or Plated</li> </ol>	<p>5. <i>Cabinet finish</i></p> <p>6. <i>Pull finish</i> Painted or Plated</p> <p>Product on this page excluding J-pull option will accept woodgrain laminate where laminate is currently an option. List price for woodgrain laminate options will be current published laminate list price plus 10%.</p> <p><b>Keying instructions must accompany all orders, refer to page 523 . Pedestals do not come with lock included.</b> Random locks are factory installed. Key-alike are field installed using the KnollKey order form. Each locking pedestal on this page counts for one lock core.</p> <p>Box-box-file configuration pedestals with wood drawers includes pencil tray and two tray dividers in top box drawer.</p> <p>Finished back must be ordered separately to achieve full depth without a modesty.(page279)</p>
		<p><b>Products on this page are 28-3/8" high.</b> 28<sup>3</sup>/<sub>8</sub>"h "desk height" products should not be mixed with 26<sup>1</sup>/<sub>2</sub>"h components. 28<sup>3</sup>/<sub>8</sub>"h components when used with 1<sup>1</sup>/<sub>4</sub>" worksurfaces achieve overall desk height of 29<sup>3</sup>/<sub>8</sub>"h. 28-3/8" "desk height" products may be specified for freestanding or panel based applications.</p> <p>File drawers include file bars for front to back and side to side filing.</p> <p>File drawers support bottom loading.</p> <p>Applicable finishes are listed on page 5 and 6.</p> <p>Each pedestal may require 3 counterweights when used in unsecured fashion. (ie. Freestanding)</p> <p>1 counterweight = 10 lbs.</p>

# Pedestals, 28<sup>3</sup>/<sub>8</sub>" planning

## Open / Hinge Door

### Metal interiors

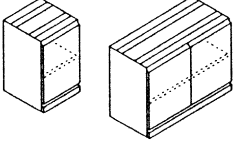
description	w	d	h	pattern no.	metal interiors L	metal interiors V1	metal interiors V2	metal interiors V3
 Pedestal, (desk height) hinge door configuration adjustable shelf	16"	19"	28 <sup>3</sup> / <sub>8</sub> "	<b>RP161L(L/R)</b> ( ) ( ) ( ) ( )	\$954.	\$1,021.	\$1,176.	\$1,588.
	16"	23"	28 <sup>3</sup> / <sub>8</sub> "	<b>RP162L(L/R)</b> ( ) ( ) ( ) ( )	1,159.	1,243.	1,428.	1,928.
	16"	29"	28 <sup>3</sup> / <sub>8</sub> "	<b>RP163L(L/R)</b> ( ) ( ) ( ) ( )	1,324.	1,423.	1,636.	2,210.
	30"	19"	28 <sup>3</sup> / <sub>8</sub> "	<b>RP301L</b> ( ) ( ) ( ) ( )	1,233.	1,321.	1,519.	2,050.
	30"	23"	28 <sup>3</sup> / <sub>8</sub> "	<b>RP302L</b> ( ) ( ) ( ) ( )	1,440.	1,546.	1,775.	2,397.
	36"	19"	28 <sup>3</sup> / <sub>8</sub> "	<b>RP361L</b> ( ) ( ) ( ) ( )	1,562.	1,674.	1,927.	2,602.
	36"	23"	28 <sup>3</sup> / <sub>8</sub> "	<b>RP362L</b> ( ) ( ) ( ) ( )	1,826.	1,959.	2,253.	3,042.

Inside height clearance top shelf 11", bottom shelf 11.5" when shelf located in center position.  
Metal interior means shelf metal.

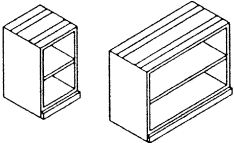
description	w	d	h	pattern no.	metal interiors L	metal interiors V1	metal interiors V2	metal interiors V3
 Pedestal, (desk height) open shelf configuration adjustable shelf	16"	19"	28 <sup>3</sup> / <sub>8</sub> "	<b>RP161M</b> ( ) ( ) ( )	724.	780.	895.	1,208.
	16"	23"	28 <sup>3</sup> / <sub>8</sub> "	<b>RP162M</b> ( ) ( ) ( )	847.	908.	1,044.	1,409.
	16"	29"	28 <sup>3</sup> / <sub>8</sub> "	<b>RP163M</b> ( ) ( ) ( )	998.	1,071.	1,233.	1,665.
	30"	19"	28 <sup>3</sup> / <sub>8</sub> "	<b>RP301M</b> ( ) ( ) ( )	844.	905.	1,041.	1,405.
	30"	23"	28 <sup>3</sup> / <sub>8</sub> "	<b>RP302M</b> ( ) ( ) ( )	1,025.	1,099.	1,264.	1,706.
	36"	19"	28 <sup>3</sup> / <sub>8</sub> "	<b>RP361M</b> ( ) ( ) ( )	1,078.	1,159.	1,330.	1,794.
	36"	23"	28 <sup>3</sup> / <sub>8</sub> "	<b>RP362M</b> ( ) ( ) ( )	1,306.	1,400.	1,610.	2,173.

Inside height clearance top shelf 11", bottom shelf 11.5" when shelf located in center position.  
Metal interior means shelf metal.  
N=No lock option

Order Code	Specification Information
Example: <b>RP161LL(L)(M)(J)L(118)</b>	<i>To order please specify pattern number including:</i>
<b>R</b> Reff	1. <i>Hinge location, were applicable</i>
<b>P</b> Pedestal	L = left hand
<b>16</b> 16" wide (nominal)	R = right hand
<b>1</b> 19" deep (nominal)	2. <i>Finish type</i>
<b>L</b> Hinge door config.	L = laminate
<b>L</b> Left hand hinge location	1 = V1
<b>L</b> Finish type, laminate	2 = V2
<b>M</b> Interior option, metal	3 = V3
<b>J</b> Pull option, J	3. <i>Interior option</i>
<b>L</b> Lock option	M = metal (If laminate case finish- shelves painted to match; if V1, V2 or V3 case finish-shelves painted black; drawer interiors painted black metal)
<b>118</b> Cabinet finish	4. <i>Pull option</i>
<b>118</b> Pull finish	D = metal D-pull (finish optional)

*To order please specify pattern number including:*

- Hinge location, were applicable*  
L = left hand  
R = right hand
- Finish type*  
L = laminate  
1 = V1  
2 = V2  
3 = V3
- Interior option*  
M = metal (If laminate case finish- shelves painted to match; if V1, V2 or V3 case finish-shelves painted black; drawer interiors painted black metal)
- Pull option*  
D = metal D-pull (finish optional)  
J = routed J-pull (finish matches case)  
C = nickel finish C-pull (nickel finish only)  
S = S-pull (stainless steel finish only)  
R = Cylinder  
T = Tab  
F = Bar  
H = Out Line

1. *Lock option*  
Optional hinged door configurations only  
Pedestals with drawers always lock drilled  
L = drilled to accept lock  
N = no drilling

2. *Cabinet finish*

3. *Pull finish*  
Painted or Plated

Product on this page excluding J-pull option will accept woodgrain laminate where laminate is currently an option.  
List price for woodgrain laminate options will be current published laminate list price plus 10%.

**Keying instructions must accompany all orders, refer to page 523 . Pedestals do not come with lock included.** Random locks are factory installed. Key-alike are field installed using the KnollKey order form. Each locking pedestal on this page counts for one lock core.

**Application Notes**

**Products on this page are 28-3/8" high.** 28<sup>3</sup>/<sub>8</sub>"h "desk height" products should not be mixed with 26<sup>1</sup>/<sub>2</sub>"h components. 28<sup>3</sup>/<sub>8</sub>"h components when used with 1<sup>1</sup>/<sub>4</sub>" worksurfaces achieve overall desk height of 29<sup>3</sup>/<sub>8</sub>"h. 28-3/8" "desk height" products may be specified for freestanding or panel based applications.

Applicable finishes are listed on page 5 and 6.

Finished back must be ordered separately to achieve full depth without a modesty. (page 272)

For Open pedestals;  
1. Finish type  
2. Interior option  
3. Cabinet finish

# Pedestals, 28<sup>3</sup>/<sub>8</sub>" planning

## Open / Hinge Door

### Wood interiors

Reff Profiles

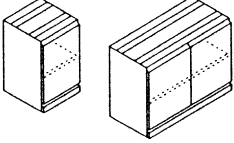
description	w	d	h	pattern no.	wood	wood	wood	wood	list
					interiors	interiors	interiors	interiors	
					L	V1	V2	V3	
Pedestal, (desk height) hinge door configuration adjustable shelf 	16"	19"	28 <sup>3</sup> / <sub>8</sub> "	RP161L(L/R) ( ) ( ) ( ) ( )	\$1,044.	\$1,119.	\$1,287.	\$1,738.	
	16"	23"	28 <sup>3</sup> / <sub>8</sub> "	RP162L(L/R) ( ) ( ) ( ) ( )	1,254.	1,342.	1,545.	2,086.	
	16"	29"	28 <sup>3</sup> / <sub>8</sub> "	RP163L(L/R) ( ) ( ) ( ) ( )	1,419.	1,520.	1,746.	2,357.	
	30"	19"	28 <sup>3</sup> / <sub>8</sub> "	RP301L ( ) ( ) ( ) ( )	1,321.	1,419.	1,633.	2,205.	
	30"	23"	28 <sup>3</sup> / <sub>8</sub> "	RP302L ( ) ( ) ( ) ( )	1,533.	1,646.	1,891.	2,553.	
	36"	19"	28 <sup>3</sup> / <sub>8</sub> "	RP361L ( ) ( ) ( ) ( )	1,656.	1,772.	2,037.	2,750.	
	36"	23"	28 <sup>3</sup> / <sub>8</sub> "	RP362L ( ) ( ) ( ) ( )	1,919.	2,057.	2,363.	3,190.	

Inside height clearance top shelf 11", bottom shelf 11.5" when shelf located in center position.

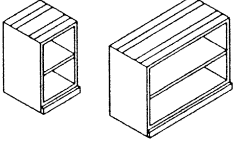
Pedestal, (desk height) open shelf configuration adjustable shelf 	16"	19"	28 <sup>3</sup> / <sub>8</sub> "	RP161M ( ) ( ) ( )	820.	873.	1,007.	1,359.	
	16"	23"	28 <sup>3</sup> / <sub>8</sub> "	RP162M ( ) ( ) ( )	940.	1,010.	1,162.	1,569.	
	16"	29"	28 <sup>3</sup> / <sub>8</sub> "	RP163M ( ) ( ) ( )	1,092.	1,168.	1,348.	1,820.	
	30"	19"	28 <sup>3</sup> / <sub>8</sub> "	RP301M ( ) ( ) ( )	938.	1,004.	1,153.	1,557.	
	30"	23"	28 <sup>3</sup> / <sub>8</sub> "	RP302M ( ) ( ) ( )	1,117.	1,198.	1,380.	1,860.	
	36"	19"	28 <sup>3</sup> / <sub>8</sub> "	RP361M ( ) ( ) ( )	1,169.	1,258.	1,444.	1,952.	
	36"	23"	28 <sup>3</sup> / <sub>8</sub> "	RP362M ( ) ( ) ( )	1,397.	1,493.	1,719.	2,322.	

Inside height clearance top shelf 11", bottom shelf 11.5" when shelf located in center position.

N=No Lock option

Pedestal, (desk height) finished back 	16"	1"	28 <sup>3</sup> / <sub>8</sub> "	RPDHB16 ( ) ( )	126.	128.	149.	201.	
	19"	1"	28 <sup>3</sup> / <sub>8</sub> "	RPDHB19 ( ) ( )	132.	134.	156.	212.	
	30"	1"	28 <sup>3</sup> / <sub>8</sub> "	RPDHB30 ( ) ( )	249.	257.	294.	397.	
	36"	1"	28 <sup>3</sup> / <sub>8</sub> "	RPDHB36 ( ) ( )	296.	305.	350.	473.	

pedestal backs for pedestals with metal or wood interiors

Order Code	Specification Information
Example: <b>RP161LL(L)(W)(J)L(118)</b>	
<b>R</b>	Reff
<b>P</b>	Pedestal
<b>16</b>	16" wide (nominal)
<b>1</b>	19" deep (nominal)
<b>L</b>	Hinge door config.
<b>L</b>	Left hand hinge location
<b>L</b>	Finish type, laminate
<b>W</b>	Interior option, wood
<b>J</b>	Pull option, J
<b>L</b>	Lock option
<b>118</b>	Cabinet finish
<b>118</b>	Pull finish

<b>To order please specify pattern number including:</b>
1. <i>Hinge location, were applicable</i> L = left hand R = right hand
2. <i>Finish type</i> L = laminate 1 = V1 2 = V2 3 = V3
3. <i>Interior option</i> W = wood (shelves match case finish: L,V1,V2 or V3; drawer interiors cherry veneer)
4. <i>Pull option</i> D = metal D-pull (finish optional) J = routed J-pull (finish matches case) C = nickel finish C-pull (nickel finish only) S = S-pull (stainless steel finish only) F = Bar pull H = Outline pull T = Tab pull R = Cylinder pull

- Lock option*  
Optional hinged door configurations only  
Lock default is Black  
L = drilled to accept lock  
N = no drilling
- Cabinet finish*
- Pull finish*  
Painted or Plated

Product on this page excluding J-pull option will accept woodgrain laminate where laminate is currently an option.  
List price for woodgrain laminate options will be current published laminate list price plus 10%.

**Keying instructions must accompany all orders, refer to page 523 . Pedestals do not come with lock included.** Random locks are factory installed. Key-alike are field installed using the KnollKey order form. Each locking pedestal on this page counts for one lock core.

#### Application Notes

**Products on this page are 28-3/8" high.** 28<sup>3</sup>/<sub>8</sub>"h "desk height" products should not be mixed with 26<sup>1</sup>/<sub>2</sub>"h components. 28<sup>3</sup>/<sub>8</sub>"h components when used with 1<sup>1</sup>/<sub>4</sub>" worksurfaces achieve overall desk height of 29<sup>3</sup>/<sub>8</sub>"h. 28-3/8" "desk height" products may be specified for freestanding or panel based applications.

Applicable finishes are listed on page 5 and 6.

For Open pedestals;  
1. Finish type  
2. Interior option  
3. Cabinet finish

Finished back must be ordered separately to achieve full depth without a modesty.(page272)



Pedestals, 28<sup>3</sup>/<sub>8</sub>" planning  
*Open / Hinge Door*  
*Wood interiors*



description	w	d	h	pattern no.	wood interiors L	wood interiors V1	wood interiors V2	wood interiors V3	list
Counter weight (for file/file configuration pedestals when used in freestanding applications)	-	-	-	<b>RCOUNTWT</b>					\$97.

Order Code	Specification Information	Application Notes
Example: <b>RP161LL(L)(W)(J)L(118)</b>	<i>To order please specify pattern number including:</i>	<p><b>Products on this page are 28-3/8" high.</b> 28<sup>3</sup>/<sub>8</sub>"h "desk height" products should not be mixed with 26<sup>1</sup>/<sub>2</sub>"h components. 28<sup>3</sup>/<sub>8</sub>"h components when used with 1<sup>1</sup>/<sub>4</sub>" worksurfaces achieve overall desk height of 29<sup>3</sup>/<sub>8</sub>"h. 28-3/8" "desk height" products may be specified for freestanding or panel based applications.</p> <p>Applicable finishes are listed on page 5 and 6.</p> <p>For Open pedestals;            1. Finish type            2. Interior option            3. Cabinet finish</p> <p>Finished back must be ordered separately to achieve full depth without a modesty.(page272)</p>
<b>R</b> Reff		
<b>P</b> Pedestal		
<b>16</b> 16" wide ( <i>nominal</i> )	1. <i>Hinge location, were applicable</i> L = left hand R = right hand	
<b>1</b> 19" deep ( <i>nominal</i> )	2. <i>Finish type</i> L = laminate 1 = V1 2 = V2 3 = V3	
<b>L</b> Hinge door config.	3. <i>Interior option</i> W = wood (shelves match case finish: L,V1,V2 or V3; drawer interiors cherry veneer)	
<b>L</b> Left hand hinge location	4. <i>Pull option</i> D = metal D-pull (finish optional) J = routed J-pull (finish matches case) C = nickel finish C-pull (nickel finish only) S = S-pull (stainless steel finish only) F = Bar pull H = Outline pull T = Tab pull R = Cylinder pull	
<b>L</b> Finish type, laminate	5. <i>Lock option</i> Optional hinged door configurations only Lock default is Black L = drilled to accept lock N = no drilling	
<b>W</b> Interior option, wood	6. <i>Cabinet finish</i> 7. <i>Pull finish</i> Painted or Plated	
<b>J</b> Pull option, J	Product on this page excluding J-pull option will accept woodgrain laminate where laminate is currently an option. List price for woodgrain laminate options will be current published laminate list price plus 10%.	
<b>L</b> Lock option		
<b>118</b> Cabinet finish		
<b>118</b> Pull finish		

# Pedestals, 28<sup>3</sup>/<sub>8</sub>" planning

## *Metal accessories for pedestals*

Reff Profiles

description	w	d	h	pattern no.	list
Metal box divider, for desk height products 				<b>RDHMBD</b>	\$28.
	for 16" w desk height metal box drawer				
Metal file drawer divider, for desk height products 				<b>RDHMFD</b>	28.
	for 16" w desk height metal file drawer				
Metal lateral drawer divider, for desk height products 				<b>RDHMLD</b>	22.
	for 20" and 24" deep metal lateral drawers				

Order Code	Specification Information	Application Notes
Example: <b>RDHMBD</b>		
<b>R</b>	Reff	
<b>DH</b>	Desk height	
<b>M</b>	Metal	
<b>B</b>	Box	
<b>D</b>	Divider	

Pedestals, 28<sup>3</sup>/<sub>8</sub>" planning  
22<sup>3</sup>/<sub>8</sub>" high  
Metal interiors

description	w	d	h	pattern no.	metal interiors L	metal interiors V1	metal interiors V2	metal interiors V3
 Pedestal, (desk height planning) box/file configuration	16"	19"	22 <sup>3</sup> / <sub>8</sub> "	<b>RP161R</b> ( ) ( ) L ( ) ( ) ( )	\$1,086.	\$1,162.	\$1,333.	\$1,793.
	16"	23"	22 <sup>3</sup> / <sub>8</sub> "	<b>RP162R</b> ( ) ( ) L ( ) ( ) ( )	1,134.	1,215.	1,395.	1,876.
	19"	19"	22 <sup>3</sup> / <sub>8</sub> "	<b>RP191R</b> ( ) ( ) L ( ) ( ) ( )	1,139.	1,219.	1,399.	1,882.
	19"	23"	22 <sup>3</sup> / <sub>8</sub> "	<b>RP192R</b> ( ) ( ) L ( ) ( ) ( )	1,190.	1,275.	1,464.	1,969.
	30"	19"	22 <sup>3</sup> / <sub>8</sub> "	<b>RP301R</b> ( ) ( ) L ( ) ( ) ( )	1,156.	1,240.	1,422.	1,913.
	30"	23"	22 <sup>3</sup> / <sub>8</sub> "	<b>RP302R</b> ( ) ( ) L ( ) ( ) ( )	1,218.	1,306.	1,496.	2,012.
	36"	19"	22 <sup>3</sup> / <sub>8</sub> "	<b>RP361R</b> ( ) ( ) L ( ) ( ) ( )	1,232.	1,319.	1,515.	2,038.
	36"	23"	22 <sup>3</sup> / <sub>8</sub> "	<b>RP362R</b> ( ) ( ) L ( ) ( ) ( )	1,291.	1,382.	1,587.	2,136.

Pedestals may require counterweights when used in unsecured fashion (ie freestanding)

\*3 counterweights per pedestal

 Pedestal, (desk height planning) open bookcase configuration, with adjustable shelf	30"	19"	22 <sup>3</sup> / <sub>8</sub> "	<b>RP301S</b> ( ) ( ) ( )	770.	828.	951.	1,284.
	30"	23"	22 <sup>3</sup> / <sub>8</sub> "	<b>RP302S</b> ( ) ( ) ( )	938.	1,007.	1,155.	1,560.
	36"	19"	22 <sup>3</sup> / <sub>8</sub> "	<b>RP361S</b> ( ) ( ) ( )	985.	1,059.	1,217.	1,643.
	36"	23"	22 <sup>3</sup> / <sub>8</sub> "	<b>RP362S</b> ( ) ( ) ( )	1,193.	1,279.	1,470.	1,984.

 Pedestal, (desk height planning) open file configuration	30"	19"	22 <sup>3</sup> / <sub>8</sub> "	<b>RP301T</b> ( ) ( ) L ( ) ( ) ( )	828.	886.	1,009.	1,342.
	30"	23"	22 <sup>3</sup> / <sub>8</sub> "	<b>RP302T</b> ( ) ( ) L ( ) ( ) ( )	996.	1,065.	1,213.	1,618.
	36"	19"	22 <sup>3</sup> / <sub>8</sub> "	<b>RP361T</b> ( ) ( ) L ( ) ( ) ( )	1,043.	1,117.	1,275.	1,701.
	36"	23"	22 <sup>3</sup> / <sub>8</sub> "	<b>RP362T</b> ( ) ( ) L ( ) ( ) ( )	1,251.	1,337.	1,528.	2,042.

Order Code	Specification Information	Application Notes
Example: <b>RP161R</b> ( ) ( ) L ( ) ( ) ( )	To order please specify pattern number including:	Use 28 <sup>3</sup> / <sub>8</sub> " desk height planning.
<b>R</b> Reff		Applied back ordered separately for finished back.
<b>P</b> Pedestal		File drawer support bottom loading
<b>16</b> 16" wide (nominal)	1. <i>Finish type</i>	File drawers include bars for front to back and side to side filing.
<b>1</b> 19" deep (nominal)	L = Laminate	Pencil trays ordered separately for all metal interiors.
<b>R</b> Box/File configuration	1 = V1	
<b>2</b> Finish type	2 = V2	
<b>M</b> Interior option	3 = V3	
<b>H</b> Finish Pull option	2. Interior option: M = Metal	
<b>L</b> Lock option	3. <i>Pull option</i>	
<b>B</b> Lock finish	B = No pull	
<b>V316</b> Cabinet finish	C = Metal C-pull	
<b>PU</b> Satin Nickel	D = Metal D-pull	
	J = Routed J-pull	
	S = Metal S-pull	
	R = Cylinder	
	T = Tab	
	F = Bar	
	H = Outline	
	4. <i>Lock option</i>	
	Pedestals with drawers always lock drilled	
	L = drilled to accept lock	
	5. <i>Lock finish</i>	
	B = Black	
	S = Matt silver	
	6. <i>Cabinet finish:</i>	
	L, V1, V2, V3	
	7. <i>Pull finish</i>	
	Painted or Plated	
		Open book case:
		1. <i>Finish type</i>
		L = Laminate
		1 = V1
		2 = V2
		3 = V3
		2. Interior option
		3. Cabinet finish

Pedestals, 28<sup>3</sup>/<sub>8</sub>" planning  
22<sup>3</sup>/<sub>8</sub>" high  
Wood interiors

Reff Profiles

description	w	d	h	pattern no.	wood interiors L	wood interiors V1	wood interiors V2	wood interiors V3
 Pedestal, (desk height planning) box/file configuration	16"	19"	22 <sup>3</sup> / <sub>8</sub> "	<b>RP161R</b> ( ) ( ) L ( ) ( ) ( )	\$1,151.	\$1,230.	\$1,414.	\$1,901.
	16"	23"	22 <sup>3</sup> / <sub>8</sub> "	<b>RP162R</b> ( ) ( ) L ( ) ( ) ( )	1,279.	1,370.	1,572.	2,116.
	19"	19"	22 <sup>3</sup> / <sub>8</sub> "	<b>RP191R</b> ( ) ( ) L ( ) ( ) ( )	1,208.	1,291.	1,484.	1,995.
	19"	23"	22 <sup>3</sup> / <sub>8</sub> "	<b>RP192R</b> ( ) ( ) L ( ) ( ) ( )	1,342.	1,438.	1,650.	2,221.
	30"	19"	22 <sup>3</sup> / <sub>8</sub> "	<b>RP301R</b> ( ) ( ) L ( ) ( ) ( )	1,381.	1,479.	1,698.	2,284.
	30"	23"	22 <sup>3</sup> / <sub>8</sub> "	<b>RP302R</b> ( ) ( ) L ( ) ( ) ( )	1,621.	1,734.	1,987.	2,676.
	36"	19"	22 <sup>3</sup> / <sub>8</sub> "	<b>RP361R</b> ( ) ( ) L ( ) ( ) ( )	1,703.	1,823.	2,095.	2,820.
	36"	23"	22 <sup>3</sup> / <sub>8</sub> "	<b>RP362R</b> ( ) ( ) L ( ) ( ) ( )	1,981.	2,123.	2,435.	3,284.

Pedestals may require counterweights when used in unsecured fashion (ie freestanding)

\*3 counterweights per pedestal

 Pedestal, (desk height planning) open bookcase configuration, with adjustable shelf	30"	19"	22 <sup>3</sup> / <sub>8</sub> "	<b>RP301S</b> ( ) ( ) ( )	858.	917.	1,054.	1,423.
	30"	23"	22 <sup>3</sup> / <sub>8</sub> "	<b>RP302S</b> ( ) ( ) ( )	1,020.	1,094.	1,259.	1,698.
	36"	19"	22 <sup>3</sup> / <sub>8</sub> "	<b>RP361S</b> ( ) ( ) ( )	1,069.	1,149.	1,322.	1,784.
	36"	23"	22 <sup>3</sup> / <sub>8</sub> "	<b>RP362S</b> ( ) ( ) ( )	1,278.	1,366.	1,572.	2,122.

 Pedestal, (desk height planning) open file configuration	30"	19"	22 <sup>3</sup> / <sub>8</sub> "	<b>RP301T</b> ( ) ( ) L ( ) ( ) ( )	916.	975.	1,112.	1,481.
	30"	23"	22 <sup>3</sup> / <sub>8</sub> "	<b>RP302T</b> ( ) ( ) L ( ) ( ) ( )	1,078.	1,152.	1,317.	1,756.
	36"	19"	22 <sup>3</sup> / <sub>8</sub> "	<b>RP361T</b> ( ) ( ) L ( ) ( ) ( )	1,127.	1,207.	1,380.	1,842.
	36"	23"	22 <sup>3</sup> / <sub>8</sub> "	<b>RP362T</b> ( ) ( ) L ( ) ( ) ( )	1,336.	1,424.	1,630.	2,180.

Order Code	Specification Information	Application Notes
Example: <b>RP161R</b> ( ) ( ) ( ) ( ) ( ) ( )	<i>To order please specify pattern number including:</i>	<b>Bookcase</b>
<b>R</b> Reff	1. <i>Finish type</i> L = Laminate 1 = V1 2 = V2 3 = V3	Use 28 <sup>3</sup> / <sub>8</sub> " desk height planning.
<b>P</b> Pedestal	2. <i>Interior option:</i> W = wood	Applied back ordered separately for finished back.
<b>16</b> 16" wide	3. <i>Pull option</i> B = No pull C = Metal C-pull D = Metal D-pull J = Routed J-pull S = Metal S-pull	File drawer support bottom loading
<b>1</b> 19" deep (nominal)	R = Cylinder T = Tab F = Bar H = Outline	Always open configuration.
<b>R</b> Box/File configuration	4. <i>Lock option</i> Pedestals with drawers always lock drilled L = drilled to accept lock	Adjustable Shelves.
<b>2</b> Finish type, V2	5. <i>Lock finish</i> B = Black S = Matt silver	Bottom shelf fixed.
<b>W</b> Interior option, wood	6. <i>Cabinet finish</i>	Removable back.
<b>H</b> Pull option	7. <i>Pull finish</i>	File drawers include bars for front to back and side to side filing.
<b>L</b> Lock option files		Pencil trays included in all wood interiors.
<b>111</b> Lock finish		
<b>V316</b> Cabinet finish		
<b>111</b> Pull finish		

Pedestals, 28<sup>3</sup>/<sub>8</sub>" planning  
22<sup>3</sup>/<sub>8</sub>" high  
Wood interiors

description	w	d	h	pattern no.	wood interiors L	wood interiors V1	wood interiors V2	wood interiors V3
Pedestal, (desk height planning)	30"	20"	22 <sup>3</sup> / <sub>8</sub> "	<b>RP301A</b> ( ) ( )	\$901.	\$963.	\$1,107.	\$1,494.
cabinet access bookcase	30"	24"	22 <sup>3</sup> / <sub>8</sub> "	<b>RP302A</b> ( ) ( )	1,071.	1,149.	1,322.	1,783.
* with removable back	36"	20"	22 <sup>3</sup> / <sub>8</sub> "	<b>RP361A</b> ( ) ( )	1,122.	1,206.	1,388.	1,873.
	36"	24"	22 <sup>3</sup> / <sub>8</sub> "	<b>RP362A</b> ( ) ( )	1,342.	1,434.	1,651.	2,228.



\*available in wood interior only.

Order Code	Specification Information	Application Notes
Example: <b>RP161R</b> ( ) ( ) ( ) ( ) ( ) ( )	<i>To order please specify pattern number including:</i>	<b>Bookcase</b>
<b>R</b> Reff	1. <i>Finish type</i> L = Laminate 1 = V1 2 = V2 3 = V3	1. Finish type 2. Interior option 3. Cabinet finish
<b>P</b> Pedestal	2. <i>Interior option:</i> W = wood	Always open configuration.
<b>16</b> 16" wide	3. <i>Pull option</i> B = No pull C = Metal C-pull D = Metal D-pull J = Routed J-pull S = Metal S-pull	Adjustable Shelves.
<b>1</b> 19" deep (nominal)	R = Cylinder T = Tab F = Bar	Bottom shelf fixed.
<b>R</b> Box/File configuration	H = Outline	Removable back.
<b>2</b> Finish type, V2	4. <i>Lock option</i> Pedestals with drawers always lock drilled L = drilled to accept lock	File drawer support bottom loading
<b>W</b> Interior option, wood	5. <i>Lock finish</i> B = Black S = Matt silver	File drawers include bars for front to back and side to side filing.
<b>H</b> Pull option	6. <i>Cabinet finish</i>	Pencil trays included in all wood interiors.
<b>L</b> Lock option files	7. <i>Pull finish</i>	
<b>111</b> Lock finish		
<b>V316</b> Cabinet finish		
<b>111</b> Pull finish		

Pedestals, 28<sup>3</sup>/<sub>8</sub>" planning  
 22<sup>3</sup>/<sub>8</sub>" high  
 Equipment Pedestals

description	w	d	h	pattern no.	wood	wood	wood	wood
					interiors L	interiors V1	interiors V2	interiors V3
Pedestal, (desk height planning)	30"	19"	22 <sup>3</sup> / <sub>8</sub> "	<b>RP301E(L/R)</b> ( ) ( ) ( ) ( ) ( ) ( )	\$1,811.	\$2,383.	\$2,634.	\$3,143.
equipment configuration	30"	23"	22 <sup>3</sup> / <sub>8</sub> "	<b>RP302E(L/R)</b> ( ) ( ) ( ) ( ) ( ) ( )	1,844.	2,426.	2,677.	3,241.
(wood interior only)	36"	19"	22 <sup>3</sup> / <sub>8</sub> "	<b>RP361E(L/R)</b> ( ) ( ) ( ) ( ) ( ) ( )	1,855.	2,432.	2,689.	3,235.
	36"	23"	22 <sup>3</sup> / <sub>8</sub> "	<b>RP362E(L/R)</b> ( ) ( ) ( ) ( ) ( ) ( )	1,886.	2,469.	2,745.	3,333.



Left hand shown



Order Code	Specification Information	Application Notes
Example: <b>RP301E(L/R)</b>	<i>To order please specify pattern number including:</i>	Lock default is black
<b>R</b> Reff		Use 28 <sup>3</sup> / <sub>8</sub> " desk height planning.
<b>P</b> Pedestal	1. <i>Finish type:</i>	Applied back ordered separately for finish back.
<b>30</b> 30" wide	L = laminate	
<b>1</b> 19" deep (nominal)	1 = V1	
<b>E</b> Equipment Ped.	2 = V2	From the viewer's perspective, the drawer location determines the pedestal Right/Left orientation.
<b>L</b> Left hand	3 = V3	
<b>V2</b> Case finish type	2. <i>Interior option: W (wood)</i>	
<b>V2</b> Front finish type	3. <i>Pull option</i>	
<b>W</b> Interior option, wood	B = No pull	
<b>H</b> Pull option	F = Bar pull	
<b>V316</b> Case finish	H = Outline pull	
<b>V316</b> Front finish	R = Cylinder pull	
<b>111</b> Pull finish	T = Tab pull	
<b>B</b> Lock option	4. Case finish	
	5. Pull finish:	
	Painted or Plated	
	6. <i>Lock option</i>	
	L = Lock hole drilled	
	N = No lock drilling	

Equipment Pedestal's Clearance:

**Enclosed Area:**  
 For 30" w X 19" d 22.5" w X 16.5" d X 14.25" h  
 For 30" w X 23" d 22.5" w X 20.5" d X 14.25" h  
 For 36" w X 19" d 26.5" w X 16.5" d X 14.25" h  
 For 36" w X 23" d 26.5" w X 20.5" d X 14.25" h

**Open Area:**  
 For 30" w X 19" d 8" w X 17" d X 17.5" h  
 For 30" w X 23" d 8" w X 21" d X 17.5" h  
 For 36" w X 19" d 8" w X 17" d X 17.5" h  
 For 36" w X 23" d 8" w X 21" d X 17.5" h

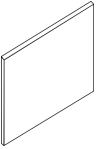
Pedestals, 28<sup>3/8</sup>" planning  
 22<sup>3/8</sup>" high  
 Pedestal back, filler and flush modesty

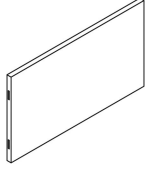
description	w	th	h	pattern no.	L	V1	V2	V3
Pedestal Back 	16"		22 <sup>3/8</sup> "	<b>RPCB16</b> ( ) ( )	\$229.	\$275.	\$316.	\$411.
	19"		22 <sup>3/8</sup> "	<b>RPCB19</b> ( ) ( )	234.	281.	323.	420.
	30"		22 <sup>3/8</sup> "	<b>RPCB30</b> ( ) ( )	257.	308.	354.	461.
	36"		22 <sup>3/8</sup> "	<b>RPCB36</b> ( ) ( )	270.	323.	372.	484.
Pedestal Filler 	6"		22 <sup>3/8</sup> "	<b>RPFC6</b> ( )	160.	192.	210.	250.
	6"		28 <sup>3/8</sup> "	<b>RPDHB6</b> ( ) ( )	193.	226.	245.	287.
Flush Modesty Panel 	42"	1"	22 <sup>3/8</sup> "	<b>RPDHC42MF</b> ( ) ( ) ( )	332.	398.	458.	595.
	48"	1"	22 <sup>3/8</sup> "	<b>RPDHC48MF</b> ( ) ( ) ( )	347.	416.	479.	623.
	54"	1"	22 <sup>3/8</sup> "	<b>RPDHC54MF</b> ( ) ( ) ( )	362.	434.	500.	649.
	60"	1"	22 <sup>3/8</sup> "	<b>RPDHC60MF</b> ( ) ( ) ( )	399.	479.	551.	716.
	66"	1"	22 <sup>3/8</sup> "	<b>RPDHC66MF</b> ( ) ( ) ( )	414.	496.	571.	742.
	72"	1"	22 <sup>3/8</sup> "	<b>RPDHC72MF</b> ( ) ( ) ( )	428.	514.	591.	769.
	78"	1"	22 <sup>3/8</sup> "	<b>RPDHC78MF</b> ( ) ( ) ( )	449.	538.	619.	805.
	84"	1"	22 <sup>3/8</sup> "	<b>RPDHC84MF</b> ( ) ( ) ( )	464.	556.	640.	832.
	90"	1"	22 <sup>3/8</sup> "	<b>RPDHC90MF</b> ( ) ( ) ( )	498.	597.	687.	893.
	96"	1"	22 <sup>3/8</sup> "	<b>RPDHC96MF</b> ( ) ( ) ( )	512.	614.	706.	918.

Order Code	Specification Information	Application Notes
Example: <b>RPCB16</b> ( ) <b>R</b> Reff <b>P</b> Pedestal <b>C</b> For use with 22 <sup>3/8</sup> " pedestal <b>B</b> Back <b>16</b> Width <b>2</b> Finish type <b>V316</b> Finish	1. <i>Finish type</i> L = Laminate 1 = V1 2 = V2 3 = V3 2. <i>Finish</i>	Lock default is black. Use 28 <sup>3/8</sup> " desk height planning. Applied back ordered separately for finished back.  <i>For Modesty panel specify:</i> 1. Modesty position: F = Flush, cantilevered R = Recessed 2. Finish type 3. Finish

description	w	d	h	pattern no.	L/V1	L/V2	L/V3	L	V1	V2	V3
Mobile Pedestal	16"	19"	23"	<b>RMPU</b> ( ) ( ) ( ) ( ) ( ) ( )	\$2,185.	\$2,230.	\$2,285.	\$2,133.	\$2,278.	\$2,607.	\$3,357.



Order Code	Specification Information	Application Notes
Example: <b>RMPU</b> ( ) ( ) ( ) ( ) ( ) ( )	<i>To order please specify pattern number including:</i>	These products are Glue and Dowel Construction
<b>R</b> Reff		
<b>M</b> Mobile	1. Lock option Pedestals with drawers always lock drilled.	Always comes with lock.
<b>P</b> Pedestal	2. Lock finish B = Black S = Matt silver	Always comes with finished back
<b>U</b> Cubby above with drawer/box/file	3. Pull option G = Grommet pull only	Grommet pull only.
<b>L</b> Lock Option	4. Case finish	Actual width = 15.94"
<b>B</b> Lock Finish	5. Front finish	Actual depth = 19.06"
<b>G</b> Pull Finish	6. Pencil tray finish Painted / Anodized	Actual total height = 23.37"
<b>V316</b> Case Finish		
<b>V316</b> Front Drawer Finish		
<b>111</b> Pencil Tray Finish		



# Credenzas, 28<sup>3</sup>/<sub>8</sub>" planning 23<sup>3</sup>/<sub>8</sub>" high, file drawer

Reff Profiles

description	w	d	h	pattern no.	L/L	L/V1	L/V2	L/V3	V1/V1	V2/V2	V3/V3
Low credenza, file drawer left and right and cubby	90"	20"	23 <sup>3</sup> / <sub>8</sub> "	<b>RRLCFDC2090</b>	\$3,336.	\$3,670.	\$3,837.	\$4,004.	\$5,004.	\$5,755.	\$7,482.
	108"	20"	23 <sup>3</sup> / <sub>8</sub> "	<b>RRLCFDC20108</b>	3,487.	3,836.	4,010.	4,185.	5,231.	6,016.	7,820.

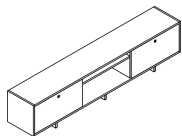

Low credenza, file drawer center with cubby	90"	20"	23 <sup>3</sup> / <sub>8</sub> "	<b>RRLCFDCC2090</b>	2,973.	3,270.	3,419.	3,567.	4,459.	5,128.	6,666.
	108"	20"	23 <sup>3</sup> / <sub>8</sub> "	<b>RRLCFDCC20108</b>	3,134.	3,448.	3,604.	3,761.	4,794.	5,407.	7,029.

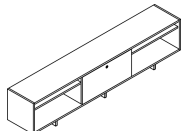

Low credenza, left	60"	20"	23 <sup>3</sup> / <sub>8</sub> "	<b>RRLCFDCL2060</b>	2,305.	2,535.	2,651.	2,766.	3,457.	3,976.	5,169.
	72"	20"	23 <sup>3</sup> / <sub>8</sub> "	<b>RRLCFDCL2072</b>	2,399.	2,639.	2,758.	2,878.	3,598.	4,138.	5,379.

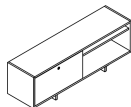

Left hand credenza; File drawer is on left.

*Left hand credenza shown*

Low credenza, right	60"	20"	23 <sup>3</sup> / <sub>8</sub> "	<b>RRLCFDCR2060</b>	2,305.	2,535.	2,651.	2,766.	3,457.	3,976.	5,169.
	72"	20"	23 <sup>3</sup> / <sub>8</sub> "	<b>RRLCFDCR2072</b>	2,399.	2,639.	2,758.	2,878.	3,598.	4,138.	5,379.

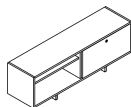

Right hand credenza; File drawer is on right.

*Right hand credenza shown*

Order Code	Specification Information	Application Notes
Example: <b>RRLCFDC2090</b>	<i>To order please specify pattern number including:</i>	These products are Glue and Dowel Construction
<b>RR</b> Reff		Nominal depth 20"
<b>LC</b> Low Credenza		Actual depth 19"
<b>FDC</b> File Drawer with cubby		All credenzas with file drawers may require counter weights when used in an unsecured fashion (ie. free-standing).
<b>20</b> 20" deep		If file drawer on right side, credenza is right handed.
<b>90</b> 90" wide	1. Lock option: Drawers are always lock drilled. L=drilled to accept lock	Grommet Pull option for these products.
<b>L</b> Lock option	2. Lock finish: B=Black S=Matte Silver	Locks on wood and Laminate doors. No locks on glass doors.
<b>S</b> Lock finish	3. Pull option Grommet pull, only	Legs shipped with credenza.
<b>G</b> Pull option	4. Pull finish Painted / Plated	Legs available in painted finish.
<b>115</b> Pull finish	5. Leg finish Painted / Plated	Shelves are fixed.
<b>115</b> Leg finish	6. Case finish: V316	Glass top and cushion sold separately.
<b>V316</b> Case option	7. Front finish: V316	
<b>V316</b> Case finish		

# Credenzas, 28<sup>3</sup>/<sub>8</sub>" planning 23<sup>3</sup>/<sub>8</sub>" high, open

Reff Profiles

description	w	d	h	pattern no.	L	V1	V2	V3
Low credenza, open with cubby 	60"	20"	23 <sup>3</sup> / <sub>8</sub> "	<b>RRLCO2060</b> ( ) ( )	\$2,044.	\$2,902.	\$3,338.	\$4,340.
	72"	20"	23 <sup>3</sup> / <sub>8</sub> "	<b>RRLCO2072</b> ( ) ( )	2,048.	3,031.	3,486.	4,532.
	90"	20"	23 <sup>3</sup> / <sub>8</sub> "	<b>RRLCO2090</b> ( ) ( )	2,499.	3,773.	4,339.	5,640.
	108"	20"	23 <sup>3</sup> / <sub>8</sub> "	<b>RRLCO20108</b> ( ) ( )	2,654.	4,008.	4,609.	5,992.

## Order Code

Example:	<b>RRLCO2060</b> ( ) ( )
<b>RR</b>	Reffresh
<b>LC</b>	Low Credenza
<b>O</b>	Open
<b>20</b>	20" deep
<b>60</b>	60" wide
<b>115</b>	Leg finish
<b>2</b>	Finish type
<b>V316</b>	Case finish

## Specification Information

*To order please specify pattern number including:*

1. Leg finish  
Painted / Plated
2. Case finish type:  
L = Laminate  
1 = V1  
2 = V2  
3 = V3
3. Case finish:  
V316

## Application Notes

These products are Glue and Dowel Construction

Legs shipped with credenza.

Legs available in painted and plated finish.

Shelves are fixed.

Glass top and cushion sold separately.

Nominal depth 20"

Actual depth 19"

All credenzas with file drawers may require counter weights when used in an unsecured fashion (ie. free-standing).

Credenzas, 28<sup>3/8</sup>" planning  
23<sup>3/8</sup>" high sliding door  
Glass door

description	w	d	h	pattern no.	L/GL	V1/GL	V2/GL	V3/GL
Low credenza, sliding glass door	90"	20"	23 <sup>3/8</sup> "	<b>RRLCSGD2090</b> ( ) ( ) ( ) ( ) ( )	\$4,572.	\$5,487.	\$6,310.	\$8,203.
	108"	20"	23 <sup>3/8</sup> "	<b>RRLCSGD20108</b> ( ) ( ) ( ) ( ) ( )	5,091.	6,109.	7,025.	9,133.

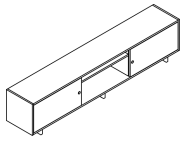

Low credenza, sliding glass door left	60"	20"	23 <sup>3/8</sup> "	<b>RRLCSGDL2060</b> ( ) ( ) ( ) ( ) ( )	3,049.	3,659.	4,208.	5,470.
	72"	20"	23 <sup>3/8</sup> "	<b>RRLCSGDL2072</b> ( ) ( ) ( ) ( ) ( )	3,218.	3,862.	4,441.	5,774.

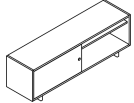

Left hand shown

Low credenza, sliding glass door right	60"	20"	23 <sup>3/8</sup> "	<b>RRLCSGDR2060</b> ( ) ( ) ( ) ( ) ( )	3,049.	3,659.	4,208.	5,470.
	72"	20"	23 <sup>3/8</sup> "	<b>RRLCSGDR2072</b> ( ) ( ) ( ) ( ) ( )	3,218.	3,862.	4,441.	5,774.

Order Code	Specification Information	Application Notes
Example: <b>RRLCSGD2090</b> ( ) ( ) ( ) ( ) ( )	<i>To order please specify pattern number including:</i>	These products are Glue and Dowel Construction
<b>RR</b> Reff	1. Pull option	Nominal depth 20"
<b>LC</b> Low Credenza	Grommet pull	Actual depth 19"
<b>SGD</b> Sliding Glass Door	2. Pull finish	Grommet Pull option for these products.
<b>20</b> 20" deep	Painted / Plated	No locks on glass doors.
<b>90</b> 90" wide	3. Leg finish	Legs shipped with credenza.
<b>G</b> Pull tpye	Painted / Plated	Shelves are fixed.
<b>PN</b> Pull finish	4. Case finish	Glass top and cushion sold separately.
<b>115</b> Leg finish	L, V1, V2, V3	
<b>V316</b> Case finish	5. Glass frame finish:	All sliding doors including wood, laminate and glass are non-locking.
<b>AN</b> Glass frame finish, Anodized black	Anodized or Painted	
<b>GL11</b> Door / front glass finish	6. Glass finish:	
	GL11, GL15, GL18	

Credenzas, 28<sup>3</sup>/<sub>8</sub>" planning  
 23<sup>3</sup>/<sub>8</sub>" high sliding door  
 Wood / Laminate door

Reff Profiles

description	w	d	h	pattern no.	L/L	L/V1	L/V2	L/V3	V1/V1	V2/V2	V3/V3
Low credenza, sliding wood/ laminate door	90"	20"	23 <sup>3</sup> / <sub>8</sub> "	<b>RRLCSWD2090</b> ( ) ( ) ( ) ( )	\$3,553.	\$3,909.	\$4,086.	\$4,264.	\$5,152.	\$5,925.	\$7,703.
	108"	20"	23 <sup>3</sup> / <sub>8</sub> "	<b>RRLCSWD20108</b> ( ) ( ) ( ) ( )	3,926.	4,319.	4,515.	4,711.	5,693.	6,547.	8,511.

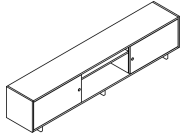

Low credenza, sliding wood/ laminate door left	60"	20"	23 <sup>3</sup> / <sub>8</sub> "	<b>RRLCSWDL2060</b> ( ) ( ) ( ) ( )	2,470.	2,717.	2,841.	2,964.	3,582.	4,119.	5,355.
	72"	20"	23 <sup>3</sup> / <sub>8</sub> "	<b>RRLCSWDL2072</b> ( ) ( ) ( ) ( )	2,584.	2,842.	2,971.	3,100.	3,746.	4,308.	5,601.

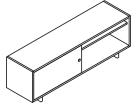

Left hand shown

Low credenza, sliding wood/ laminate door right	60"	20"	23 <sup>3</sup> / <sub>8</sub> "	<b>RRLCSWDR2060</b> ( ) ( ) ( ) ( )	2,470.	2,717.	2,841.	2,964.	3,582.	4,119.	5,355.
	72"	20"	23 <sup>3</sup> / <sub>8</sub> "	<b>RRLCSWDR2072</b> ( ) ( ) ( ) ( )	2,584.	2,842.	2,971.	3,100.	3,746.	4,308.	5,601.

**Order Code**

Example:	<b>RRLCSWD2090</b> ( ) ( ) ( ) ( )
<b>RR</b>	Reff
<b>LC</b>	Low Credenza
<b>SWD</b>	Sliding Wood Door
<b>20</b>	20" deep
<b>90</b>	90" wide
<b>G</b>	Pull option
<b>115</b>	Pull finish
<b>115</b>	Leg finish
<b>V316</b>	Case finish
<b>V316</b>	Door / front glass finish

**Specification Information**

To order please specify pattern number including:

1. Pull option  
Grommet
2. Pull finish  
Painted / Plated
3. Leg finish  
Painted / Plated
4. Case finish  
L, V1, V2, V3
5. Door finish  
L, V1, V2, V3

**Application Notes**

These products are Glue and Dowel Construction

Grommet Pull option for these products.

Legs shipped with credenza.

Legs available in painted finishes.

Shelves are fixed.

Glass top and cushion sold separately.

All sliding doors including wood, laminate and glass are non-locking.

Nominal depth 20"

Actual depth 19"

All credenzas with file drawers may require counter weights when used in an unsecured fashion (ie. free-standing).

# Credenzas, 28<sup>3</sup>/<sub>8</sub>" planning

## *Glass top*

Reff Profiles

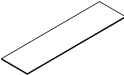
description	d	w	pattern no.	list
Lower Credenza Glass Top 	20"	30"	<b>RLCGT301()</b>	\$385.
	20"	36"	<b>RLCGT361()</b>	460.
	20"	60"	<b>RLCGT601()</b>	740.
	20"	72"	<b>RLCGT721()</b>	875.

Cabinetry

### Order Code

<i>Example:</i>	<b>RLCGT301()</b>
<b>R</b>	Reff
<b>LC</b>	Lower Credenza
<b>GT</b>	Glass Top
<b>30</b>	Width
<b>1</b>	20" deep
<b>GL35</b>	Glass finish

### Specification Information

*To order please specify pattern number including:*

- Glass finish  
GL35 Grey  
GL85 Star Clear

### Application Notes

Grommet not an option.

# Cabinets, 26 1/2" planning 49" high, metal interior

Reff Profiles

description	w	d	h	pattern no.	metal interiors L	metal interiors V1	metal interiors V2	metal interiors V3
Cabinet with hinge doors, two adjustable shelves (Requires one lock core per cabinet)	16"	20"	49"	<b>RC412C(L/R)-()()()</b>	\$1,170.	\$1,533.	\$1,764.	\$2,381.
	16"	24"	49"	<b>RC413C(L/R)-()()()</b>	1,287.	1,684.	1,938.	2,616.
	30"	20"	49"	<b>RC432C-()()()</b>	1,713.	2,247.	2,584.	3,488.
	30"	24"	49"	<b>RC433C-()()()</b>	1,895.	2,484.	2,858.	3,859.
	36"	20"	49"	<b>RC462C-()()()</b>	1,899.	2,490.	2,863.	3,866.
	36"	24"	49"	<b>RC463C-()()()</b>	2,093.	2,752.	3,164.	4,270.

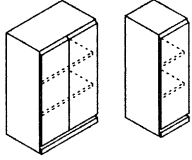

Metal interiors mean shelves metal.

4-drawer lateral file with anti-tip bar device (Requires one lock core per cabinet)	30"	20"	49"	<b>RC432F-()()L</b>	1,996.	2,616.	3,011.	4,066.
	30"	24"	49"	<b>RC433F-()()L</b>	2,203.	2,888.	3,321.	4,484.
	36"	20"	49"	<b>RC462F-()()L</b>	2,532.	3,318.	3,815.	5,150.
	36"	24"	49"	<b>RC463F-()()L</b>	2,795.	3,666.	4,216.	5,691.

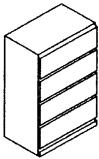

interior height clearance top drawer 10", all others 10 3/4"

Order Code	
Example: <b>RC412C</b>	
<b>R</b>	Reff
<b>C</b>	Cabinets
<b>4</b>	49" high
<b>1</b>	16" wide
<b>2</b>	20" deep
<b>C</b>	Cabinet with hinge doors
<b>L</b>	Left hand hinge location
<b>L</b>	Laminate finish type
<b>M</b>	Metal interior option
<b>T</b>	Tab pull
<b>V316</b>	Cabinet finish
<b>111</b>	Pull finish

Specification Information
<i>To order please specify pattern number including:</i>
1. Finish type
2. Interior option
3. Pull option
4. Lock option, where applicable
5. Cabinet finish: V316
6. Pull finish
<b>*After specifying product code, provide keying instructions.</b>
1. <i>Finish type:</i> L = Laminate 1 = V1 2 = V2 3 = V3

2. *Interior options:*  
M = Metal (If laminate case finish-shelves painted to match; if V1, V2 or V3 case finish-shelves painted black; drawer interiors painted black metal)

3. *Pull options:*  
D = Metal D-pull  
J = Routed pull  
C = Nickel C-pull (nickel finish only)  
S = S-pull (stainless steel finish only)  
V316

4. *Lock options:*  
L = Lock hole drilled  
N = No drilling

5. Cabinet finish: V316

6. Full finish:  
Painted or Plated

8. Refer to page 523 for keying instructions.

Key alike are field installed using the KnollKey order form. Random locks are factory installed.

Please note: Shelf adjustability is limited to approximately 2.5" up or down per shelf from predetermined shelf height.

### Application Notes

Specify finish of metal shelves to match laminate.

**Cabinets do not come with lock included. Keying instructions must accompany all cabinet orders.**

Hinge door cabinets have optional lock drilling which can be specified in the cabinet product code.

\*Wardrobe cabinets do not come equipped with coat rod and boot tray. Please specify separately. See page 420.

File drawers include file bars for front to back and side to side filing.

File drawers do not support bottom loading.

Applicable finishes are listed on page 5 and 6.

# Cabinets, 26 1/2" planning 49" high, metal interior

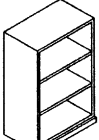
description	w	d	h	pattern no.	metal interiors L	metal interiors V1	metal interiors V2	metal interiors V3
 Open bookcase with two adjustable shelves	30"	15"	49"	<b>RC431B-()()</b>	\$1,162.	\$1,522.	\$1,754.	\$2,368.
	30"	20"	49"	<b>RC432B-()()</b>	1,311.	1,719.	1,976.	2,668.
	30"	24"	49"	<b>RC433B-()()</b>	1,480.	1,937.	2,229.	3,008.
	36"	15"	49"	<b>RC461B-()()</b>	1,289.	1,692.	1,945.	2,626.
	36"	20"	49"	<b>RC462B-()()</b>	1,456.	1,908.	2,194.	2,962.
	36"	24"	49"	<b>RC463B-()()</b>	1,637.	2,150.	2,471.	3,334.

Open cabinets require no keying instructions.  
Metal interiors mean shelves metal.

Order Code	
Example: <b>RC412C</b>	
<b>R</b>	Reff
<b>C</b>	Cabinets
<b>4</b>	49" high
<b>1</b>	16" wide
<b>2</b>	20" deep
<b>C</b>	Cabinet with hinge doors
<b>L</b>	Left hand hinge location
<b>L</b>	Laminate finish type
<b>M</b>	Metal interior option
<b>T</b>	Tab pull
<b>V316</b>	Cabinet finish
<b>111</b>	Pull finish

**Specification Information**

*To order please specify pattern number including:*

1. Finish type
2. Interior option
3. Pull option
4. Lock option, where applicable
5. Cabinet finish:  
V316
6. Pull finish

**\*After specifying product code, provide keying instructions.**

*1. Finish type:*  
L = Laminate  
1 = V1  
2 = V2  
3 = V3

*2. Interior options:*  
M = Metal (If laminate case finish-shelves painted to match; if V1, V2 or V3 case finish-shelves painted black; drawer interiors painted black metal)

*3. Pull options:*  
D = Metal D-pull  
J = Routed pull  
C = Nickel C-pull (nickel finish only)  
S = S-pull (stainless steel finish only)  
V316

*4. Lock options:*  
L = Lock hole drilled  
N = No drilling

5. Cabinet finish: V316

6. Full finish:  
Painted or Plated

8. Refer to page 523 for keying instructions.

Key alike are field installed using the KnollKey order form. Random locks are factory installed.

Please note: Shelf adjustability is limited to approximately 2.5" up or down per shelf from predetermined shelf height.

**Application Notes**

Specify finish of metal shelves to match laminate.

**Cabinets do not come with lock included. Keying instructions must accompany all cabinet orders.**

Hinge door cabinets have optional lock drilling which can be specified in the cabinet product code.

\*Wardrobe cabinets do not come equipped with coat rod and boot tray. Please specify separately. See page 420.

File drawers include file bars for front to back and side to side filing.

File drawers do not support bottom loading.

Applicable finishes are listed on page 5 and 6.

# Cabinets, 26 1/2" planning 49" high, wood interior

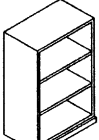
description	w	d	h	pattern no.	wood	wood	wood	wood
					interiors L	interiors V1	interiors V2	interiors V3
 Open bookcase with two adjustable shelves	30"	15"	49"	<b>RC431B-()()</b>	\$1,303.	\$1,706.	\$1,961.	\$2,648.
	30"	20"	49"	<b>RC432B-()()</b>	1,452.	1,904.	2,187.	2,953.
	30"	24"	49"	<b>RC433B-()()</b>	1,617.	2,119.	2,439.	3,293.
	36"	15"	49"	<b>RC461B-()()</b>	1,431.	1,876.	2,157.	2,911.
	36"	20"	49"	<b>RC462B-()()</b>	1,596.	2,094.	2,405.	3,246.
	36"	24"	49"	<b>RC463B-()()</b>	1,780.	2,334.	2,682.	3,620.

Open cabinets require no keying instructions

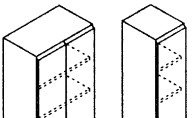
description	w	d	h	pattern no.	wood	wood	wood	wood
					interiors L	interiors V1	interiors V2	interiors V3
 Cabinet with hinge doors, two adjustable shelves (Requires one lock core per cabinet)	16"	20"	49"	<b>RC412C(L/R)-()()()</b>	1,310.	1,717.	1,973.	2,663.
	16"	24"	49"	<b>RC413C(L/R)-()()()</b>	1,429.	1,872.	2,153.	2,906.
	30"	20"	49"	<b>RC432C-()()()</b>	1,852.	2,428.	2,793.	3,770.
	30"	24"	49"	<b>RC433C-()()()</b>	2,035.	2,670.	3,068.	4,141.
	36"	20"	49"	<b>RC462C-()()()</b>	2,040.	2,673.	3,077.	4,153.
	36"	24"	49"	<b>RC463C-()()()</b>	2,238.	2,935.	3,377.	4,559.

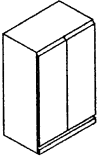
description	w	d	h	pattern no.	wood	wood	wood	wood
					interiors L	interiors V1	interiors V2	interiors V3
 Wardrobe for coat rod and boot tray* (Requires one lock core per cabinet)	30"	20"	49"	<b>RC432D-()W()()</b>	1,691.	2,215.	2,548.	3,441.
	30"	24"	49"	<b>RC433D-()W()()</b>	1,846.	2,422.	2,787.	3,762.
	36"	20"	49"	<b>RC462D-()W()()</b>	1,858.	2,438.	2,803.	3,784.
	36"	24"	49"	<b>RC463D-()W()()</b>	2,032.	2,666.	3,065.	4,138.

Order Code	Specification Information	Application Notes
Example: <b>RC412CLLWDL</b> <b>R</b> Reff <b>C</b> Cabinets <b>4</b> 49" high <b>1</b> 16" wide <b>2</b> 20" deep <b>C</b> Cabinet with hinge doors <b>L</b> Left hand hinge location <b>L</b> Laminate finish type <b>W</b> Wood interior option <b>D</b> Metal D-pull <b>L</b> Lock hole drilled	<b>To order please specify pattern number including:</b> 1. Hinge location, where applicable 2. Finish type 3. Interior option 4. Pull option 5. Lock option, where applicable 6. Finish, cabinet 7. Finish, pull when applicable 8. Keying instructions  <b>*After specifying product code, provide keying instructions.</b>  1. <i>Hinge location:</i> L = Left hand R = Right hand  2. <i>Finish type:</i> L = Laminate 1 = V1 2 = V2 3 = V3  3. <i>Interior options:</i> W = Wood (shelves match case finish: L, V1, V2 or V3; drawer interiors cherry veneer)	4. <i>Pull options:</i> D = Metal D-pull J = Routed pull C = Nickel C-pull (nickel finish only) S = S-pull (stainless steel finish only)  5. <i>Lock options:</i> L = Lock hole drilled N = No drilling  8. Refer to page 523 for keying instructions.  Key alike are field installed using the KnollKey order form. Random locks are factory installed.  Please note: Shelf adjustability is limited to approximately 2.5" up or down per shelf from predetermined shelf height.
		Specify finish of metal shelves to match laminate.  <b>Cabinets do not come with lock included. Keying instructions must accompany all cabinet orders.</b>  Hinge door cabinets have optional lock drilling which can be specified in the cabinet product code.  *Wardrobe cabinets do not come equipped with coat rod and boot tray. Please specify separately. See page 420.  File drawers include file bars for front to back and side to side filing.  File drawers do not support bottom loading.  Applicable finishes are listed on page 5 and 6.



# Cabinets, 26 1/2" planning 49" high, wood interior

description	w	d	h	pattern no.	wood	wood	wood	wood
					interiors L	interiors V1	interiors V2	interiors V3
4-drawer lateral file with anti-tip bar device (Requires one lock core per cabinet)	30"	20"	49"	<b>RC432F-()()L</b>	\$2,136.	\$2,801.	\$3,221.	\$4,348.
	30"	24"	49"	<b>RC433F-()()L</b>	2,346.	3,079.	3,534.	4,771.
	36"	20"	49"	<b>RC462F-()()L</b>	2,672.	3,500.	4,024.	5,434.
	36"	24"	49"	<b>RC463F-()()L</b>	2,935.	3,846.	4,423.	5,972.

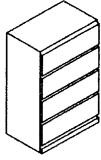

Order Code	Specification Information	Application Notes
Example: <b>RC412CLLWDL</b>	<i>To order please specify pattern number including:</i>	Specify finish of metal shelves to match laminate.
<b>R</b> Reff	1. Hinge location, where applicable	<b>Cabinets do not come with lock included. Keying instructions must accompany all cabinet orders.</b>
<b>C</b> Cabinets	2. Finish type	
<b>4</b> 49" high	3. Interior option	Hinge door cabinets have optional lock drilling which can be specified in the cabinet product code.
<b>1</b> 16" wide	4. Pull option	*Wardrobe cabinets do not come equipped with coat rod and boot tray. Please specify separately. See page 420.
<b>2</b> 20" deep	5. Lock option, where applicable	
<b>C</b> Cabinet with hinge doors	6. Finish, cabinet	File drawers include file bars for front to back and side to side filing.
<b>L</b> Left hand hinge location	7. Finish, pull when applicable	File drawers do not support bottom loading.
<b>L</b> Laminate finish type	8. Keying instructions	Applicable finishes are listed on page 5 and 6.
<b>W</b> Wood interior option	<b>*After specifying product code, provide keying instructions.</b>	
<b>D</b> Metal D-pull	<i>1. Hinge location:</i>	
<b>L</b> Lock hole drilled	L = Left hand	
	R = Right hand	
	<i>2. Finish type:</i>	
	L = Laminate	
	1 = V1	
	2 = V2	
	3 = V3	
	<i>3. Interior options:</i>	
	W = Wood (shelves match case finish: L, V1, V2 or V3; drawer interiors cherry veneer)	
	<i>4. Pull options:</i>	
	D = Metal D-pull	
	J = Routed pull	
	C = Nickel C-pull (nickel finish only)	
	S = S-pull (stainless steel finish only)	
	<i>5. Lock options:</i>	
	L = Lock hole drilled	
	N = No drilling	
	<i>8. Refer to page 523 for keying instructions.</i>	
	Key alike are field installed using the KnollKey order form. Random locks are factory installed.	
	Please note: Shelf adjustability is limited to approximately 2.5" up or down per shelf from predetermined shelf height.	

# Cabinets, 26 1/2" planning 64" high, metal interior

Reff Profiles

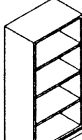
description	w	d	h	pattern no.	metal interiors L	metal interiors V1	metal interiors V2	metal interiors V3
 Cabinet with three adjustable shelves	30"	15"	64"	<b>RC631B-</b> ( ) ( ) (N)	\$1,491.	\$1,957.	\$2,252.	\$3,040.
	30"	20"	64"	<b>RC632B-</b> ( ) ( ) (N)	1,679.	2,201.	2,531.	3,416.
	30"	24"	64"	<b>RC633B-</b> ( ) ( ) (N)	1,866.	2,448.	2,817.	3,801.
	36"	15"	64"	<b>RC661B-</b> ( ) ( ) (N)	1,712.	2,243.	2,581.	3,483.
	36"	20"	64"	<b>RC662B-</b> ( ) ( ) (N)	1,904.	2,492.	2,870.	3,872.
	36"	24"	64"	<b>RC663B-</b> ( ) ( ) (N)	2,097.	2,749.	3,160.	4,267.

Open cabinets require no keying instructions.  
Metal interiors mean shelves metal.

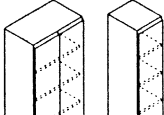
description	w	d	h	pattern no.	metal interiors L	metal interiors V1	metal interiors V2	metal interiors V3
 Cabinet with hinged doors three adjustable shelves	16"	20"	64"	<b>RC612C(L/R)-</b> ( ) ( ) ( )	1,747.	2,285.	2,630.	3,550.
	16"	24"	64"	<b>RC613C(L/R)-</b> ( ) ( ) ( )	1,947.	2,553.	2,935.	3,963.
	30"	20"	64"	<b>RC632C-</b> ( ) ( ) ( )	2,316.	3,036.	3,491.	4,713.
	30"	24"	64"	<b>RC633C-</b> ( ) ( ) ( )	2,558.	3,355.	3,853.	5,202.
	36"	20"	64"	<b>RC662C-</b> ( ) ( ) ( )	2,532.	3,318.	3,815.	5,150.
	36"	24"	64"	<b>RC663C-</b> ( ) ( ) ( )	2,773.	3,638.	4,182.	5,647.

Metal interiors mean shelves metal.

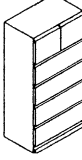
description	w	d	h	pattern no.	metal interiors L	metal interiors V1	metal interiors V2	metal interiors V3
 Cabinet with 4 files and (2) 15" doors at top	30"	20"	64"	<b>RC632F-</b> ( ) ( ) ( )	2,773.	3,638.	4,182.	5,647.
	30"	24"	64"	<b>RC633F-</b> ( ) ( ) ( )	3,065.	4,016.	4,620.	6,235.
	36"	20"	64"	<b>RC662F-</b> ( ) ( ) ( )	3,065.	4,016.	4,620.	6,235.
	36"	24"	64"	<b>RC663F-</b> ( ) ( ) ( )	3,385.	4,436.	5,100.	6,886.

Requires two lock cores per cabinet  
interior height clearance top drawer 10", all others 10 3/4"

## Order Code

Example:	<b>RC612LLMJN</b>
<b>R</b>	Reff
<b>C</b>	Cabinets
<b>6</b>	64" high
<b>1</b>	16" wide
<b>2</b>	20" deep
<b>L</b>	Left hand hinge location
<b>L</b>	Laminate finish type
<b>M</b>	Metal interior
<b>J</b>	Routed pull
<b>N</b>	No lock drilling

## Specification Information

To order please specify pattern number including:

- Hinge location, where applicable
- Finish type
- Interior option
- Pull option
- Lock option, where applicable
- Finish, cabinet
- Finish, pull when applicable
- Keying instructions

**\*After specifying product code, provide keying instructions.**

### 1. Hinge location:

L = Left hand  
R = Right hand

### 2. Finish type:

L = Laminate  
1 = V1  
2 = V2  
3 = V3

### 3. Interior options:

M = Metal (If laminate case finish-shelves painted to match; if V1, V2 or V3 case finish-shelves painted black; drawer interiors painted black metal)

### 4. Pull options:

D = Metal D-pull  
J = Routed pull  
C = Nickel C-pull (nickel finish only)  
S = S-pull (stainless steel finish only)

### 5. Lock options:

L = Lock hole drilled  
N = No lock drilling

8. Refer to page 523 for keying instructions.

Specify shelf paint finish on open cabinets with metal interiors.

Please note: Shelf adjustability is limited to approximately 2.5" up or down per shelf from predetermined shelf height.

## Application Notes

Key alike are field installed using the KnollKey order form. Random locks are factory installed.

**Cabinets do not come with lock included. Keying instructions must accompany all cabinet orders.**

Hinge door cabinets have optional lock drilling which can be specified in the cabinet product code.

### \*Note:

Wardrobe cabinets do not come equipped with coat rod and boot tray. Please specify separately. See page 420.

File drawers include file bars for front to back and side to side filing.

File drawers do not support bottom loading.

Applicable finishes are listed on page 5 and 6.

# Cabinets, 26 1/2" planning 64" high, metal interior

description	w	d	h	pattern no.	metal	metal	metal	metal
					interiors L	interiors V1	interiors V2	interiors V3
Cabinet with full height doors half wardrobe and half shelves	30"	20"	64"	<b>RC632E(L/R)-( ) ( ) ( )</b>	\$2,690.	\$3,525.	\$4,052.	\$5,472.
	30"	24"	64"	<b>RC633E(L/R)-( ) ( ) ( )</b>	2,984.	3,911.	4,498.	6,072.
	36"	20"	64"	<b>RC662E(L/R)-( ) ( ) ( )</b>	2,973.	3,895.	4,484.	6,052.
	36"	24"	64"	<b>RC663E(L/R)-( ) ( ) ( )</b>	3,297.	4,322.	4,969.	6,708.

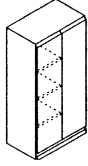

Left hand shown

Requires one lock core per cabinet  
Shelves painted metal

Cabinet with two open adjustable shelves, two hinged 22 1/2" doors	30"	20"	64"	<b>RC632H-( ) ( ) ( )</b>	2,063.	2,707.	3,112.	4,201.
	30"	24"	64"	<b>RC633H-( ) ( ) ( )</b>	2,281.	2,986.	3,437.	4,640.
	36"	20"	64"	<b>RC662H-( ) ( ) ( )</b>	2,281.	2,986.	3,437.	4,640.
	36"	24"	64"	<b>RC663H-( ) ( ) ( )</b>	2,497.	3,273.	3,764.	5,082.

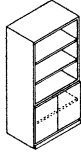

Requires one lock core per cabinet  
Shelves painted metal

Cabinet with hinged 37 1/2"H doors, two adjustable shelves, two file drawers	16"	20"	64"	<b>RC612G(L/R)-( ) ( ) ( )</b>	2,105.	2,755.	3,170.	4,279.
	16"	24"	64"	<b>RC613G(L/R)-( ) ( ) ( )</b>	2,324.	3,046.	3,501.	4,727.
	30"	20"	64"	<b>RC632G-( ) ( ) ( )</b>	2,665.	3,493.	4,016.	5,422.
	30"	24"	64"	<b>RC633G-( ) ( ) ( )</b>	2,966.	3,884.	4,467.	6,031.
	36"	20"	64"	<b>RC662G-( ) ( ) ( )</b>	2,945.	3,857.	4,437.	5,990.
	36"	24"	64"	<b>RC663G-( ) ( ) ( )</b>	3,275.	4,292.	4,935.	6,660.

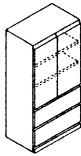

Requires two lock cores per cabinet  
Shelves painted metal, drawer interiors painted black metal

Order Code	Specification Information	Application Notes
Example: <b>RC612LLMJN</b>	<i>To order please specify pattern number including:</i>	Key alike are field installed using the KnollKey order form. Random locks are factory installed.
<b>R</b> Reff	1. Hinge location, where applicable	<b>Cabinets do not come with lock included. Keying instructions must accompany all cabinet orders.</b>
<b>C</b> Cabinets	2. Finish type	Hinge door cabinets have optional lock drilling which can be specified in the cabinet product code.
<b>6</b> 64" high	3. Interior option	<i>*Note:</i> Wardrobe cabinets do not come equipped with coat rod and boot tray. Please specify separately. See page 420.
<b>1</b> 16" wide	4. Pull option	File drawers include file bars for front to back and side to side filing.
<b>2</b> 20" deep	5. Lock option, where applicable	File drawers do not support bottom loading.
<b>L</b> Left hand hinge location	6. Finish, cabinet	Applicable finishes are listed on page 5 and 6.
<b>L</b> Laminate finish type	7. Finish, pull when applicable	
<b>M</b> Metal interior	8. Keying instructions	
<b>J</b> Routed pull	<b>*After specifying product code, provide keying instructions.</b>	
<b>N</b> No lock drilling	1. <i>Hinge location:</i> L = Left hand R = Right hand	
	2. <i>Finish type:</i> L = Laminate 1 = V1 2 = V2 3 = V3	
	3. <i>Interior options:</i> M = Metal (If laminate case finish-shelves painted to match; if V1, V2 or V3 case finish-shelves painted black; drawer interiors painted black metal)	
	4. <i>Pull options:</i> D = Metal D-pull J = Routed pull C = Nickel C-pull (nickel finish only) S = S-pull (stainless steel finish only)	
	5. <i>Lock options:</i> L = Lock hole drilled N = No lock drilling	
	8. Refer to page 523 for keying instructions.	
	Specify shelf paint finish on open cabinets with metal interiors.	
	Please note: Shelf adjustability is limited to approximately 2.5" up or down per shelf from predetermined shelf height.	

# Cabinets, 26 1/2" planning 64" high, metal interior

Reff Profiles

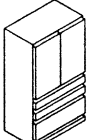
description	w	d	h	pattern no.	metal interiors L	metal interiors V1	metal interiors V2	metal interiors V3
 Cabinet with BBF below and hinged doors above	16"	20"	64"	<b>RC612P(L/R)-()()()</b>	\$2,169.	\$2,842.	\$3,268.	\$4,412.
	16"	24"	64"	<b>RC613P(L/R)-()()()</b>	2,408.	3,158.	3,627.	4,897.
	30"	20"	64"	<b>RC632P-()()()</b>	2,554.	3,347.	3,849.	5,196.
	30"	24"	64"	<b>RC633P-()()()</b>	2,818.	3,695.	4,248.	5,735.
	36"	20"	64"	<b>RC662P-()()()</b>	2,825.	3,702.	4,258.	5,749.
	36"	24"	64"	<b>RC663P-()()()</b>	3,115.	4,080.	4,696.	6,340.

Requires two lock cores per cabinet  
Shelves painted metal, drawer interiors painted black metal

## Order Code

Example:	<b>RC612LLMJN</b>
<b>R</b>	Reff
<b>C</b>	Cabinets
<b>6</b>	64" high
<b>1</b>	16" wide
<b>2</b>	20" deep
<b>L</b>	Left hand hinge location
<b>L</b>	Laminate finish type
<b>M</b>	Metal interior
<b>J</b>	Routed pull
<b>N</b>	No lock drilling

## Specification Information

To order please specify pattern number including:

- Hinge location, where applicable
- Finish type
- Interior option
- Pull option
- Lock option, where applicable
- Finish, cabinet
- Finish, pull when applicable
- Keying instructions

**\*After specifying product code, provide keying instructions.**

### 1. Hinge location:

L = Left hand  
R = Right hand

### 2. Finish type:

L = Laminate  
1 = V1  
2 = V2  
3 = V3

### 3. Interior options:

M = Metal (If laminate case finish-shelves painted to match; if V1, V2 or V3 case finish-shelves painted black; drawer interiors painted black metal)

### 4. Pull options:

D = Metal D-pull  
J = Routed pull  
C = Nickel C-pull (nickel finish only)  
S = S-pull (stainless steel finish only)

### 5. Lock options:

L = Lock hole drilled  
N = No lock drilling

8. Refer to page 523 for keying instructions.

Specify shelf paint finish on open cabinets with metal interiors.

Please note: Shelf adjustability is limited to approximately 2.5" up or down per shelf from predetermined shelf height.

## Application Notes

Key alike are field installed using the KnollKey order form. Random locks are factory installed.

**Cabinets do not come with lock included. Keying instructions must accompany all cabinet orders.**

Hinge door cabinets have optional lock drilling which can be specified in the cabinet product code.

### \*Note:

Wardrobe cabinets do not come equipped with coat rod and boot tray. Please specify separately. See page 420.

File drawers include file bars for front to back and side to side filing.

File drawers do not support bottom loading.

Applicable finishes are listed on page 5 and 6.

# Cabinets, 26 1/2" planning 64" high, wood interior

Reff Profiles

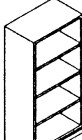
description	w	d	h	pattern no.	wood	wood	wood	wood
					interiors L	interiors V1	interiors V2	interiors V3
 Cabinet with three adjustable shelves	30"	15"	64"	<b>RC631B-</b> ( ) ( ) <b>N</b>	\$1,632.	\$2,138.	\$2,461.	\$3,323.
	30"	20"	64"	<b>RC632B-</b> ( ) ( ) <b>N</b>	1,819.	2,385.	2,744.	3,705.
	30"	24"	64"	<b>RC633B-</b> ( ) ( ) <b>N</b>	2,007.	2,630.	3,025.	4,084.
	36"	15"	64"	<b>RC661B-</b> ( ) ( ) <b>N</b>	1,851.	2,426.	2,792.	3,767.
	36"	20"	64"	<b>RC662B-</b> ( ) ( ) <b>N</b>	2,042.	2,676.	3,080.	4,158.
	36"	24"	64"	<b>RC663B-</b> ( ) ( ) <b>N</b>	2,236.	2,932.	3,370.	4,550.

Open cabinets require no keying instructions

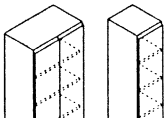
 Cabinet with hinged doors three adjustable shelves	16"	20"	64"	<b>RC612C(L/R)-</b> ( ) ( ) ( )	1,885.	2,471.	2,842.	3,836.
	16"	24"	64"	<b>RC613C(L/R)-</b> ( ) ( ) ( )	2,089.	2,736.	3,145.	4,245.
	30"	20"	64"	<b>RC632C-</b> ( ) ( ) ( )	2,455.	3,218.	3,702.	4,996.
	30"	24"	64"	<b>RC633C-</b> ( ) ( ) ( )	2,698.	3,538.	4,067.	5,490.
	36"	20"	64"	<b>RC662C-</b> ( ) ( ) ( )	2,672.	3,500.	4,024.	5,434.
	36"	24"	64"	<b>RC663C-</b> ( ) ( ) ( )	2,914.	3,820.	4,393.	5,930.

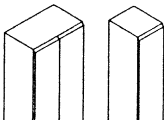
 Cabinet with hinged doors for coat rod and boot tray*	16"	20"	64"	<b>RC612D(L/R)-</b> ( ) ( ) ( )	1,651.	2,162.	2,485.	3,356.
	16"	24"	64"	<b>RC613D(L/R)-</b> ( ) ( ) ( )	1,808.	2,370.	2,726.	3,679.
	30"	20"	64"	<b>RC632D-</b> ( ) ( ) ( )	2,016.	2,641.	3,040.	4,104.
	30"	24"	64"	<b>RC633D-</b> ( ) ( ) ( )	2,077.	2,726.	3,132.	4,228.
	36"	20"	64"	<b>RC662D-</b> ( ) ( ) ( )	2,232.	2,927.	3,367.	4,544.
	36"	24"	64"	<b>RC663D-</b> ( ) ( ) ( )	2,281.	3,010.	3,459.	4,669.

Requires one lock core per cabinet

Cabinetry

Order Code	Specification Information	Application Notes
Example: <b>RC612LLWJN</b> <b>R</b> Reff <b>C</b> Cabinets <b>6</b> 64" high <b>1</b> 16" wide <b>2</b> 20" deep <b>L</b> Left hand hinge location <b>L</b> Laminate finish type <b>W</b> Wood interior <b>J</b> Routed pull <b>N</b> No lock drilling	<p><i>To order please specify pattern number including:</i></p> <ol style="list-style-type: none"> <li>Hinge location, where applicable</li> <li>Finish type</li> <li>Interior option</li> <li>Pull option</li> <li>Lock option, where applicable</li> <li>Finish, cabinet</li> <li>Finish, pull when applicable</li> <li>Keying instructions</li> </ol> <p><b>*After specifying product code, provide keying instructions.</b></p> <ol style="list-style-type: none"> <li><i>Hinge location:</i> L = Left hand R = Right hand</li> <li><i>Finish type:</i> L = Laminate 1 = V1 2 = V2 3 = V3</li> <li><i>Interior options:</i> W = Wood (shelves match case finish: L, V1, V2 or V3; drawer interiors cherry veneer)</li> </ol>	<p><i>4. Pull options:</i> D = Metal D-pull J = Routed pull C = Nickel C-pull (nickel finish only) S = S-pull (stainless steel finish only)</p> <p><i>5. Lock options:</i> L = Lock hole drilled N = No lock drilling</p> <p>8. Refer to page 523 for keying instructions.</p> <p>Specify shelf paint finish on open cabinets with metal interiors.</p> <p>Please note: Shelf adjustability is limited to approximately 2.5" up or down per shelf from predetermined shelf height.</p> <p>Key alike are field installed using the KnollKey order form. Random locks are factory installed.</p> <p><b>Cabinets do not come with lock included. Keying instructions must accompany all cabinet orders.</b></p> <p>Hinge door cabinets have optional lock drilling which can be specified in the cabinet product code.</p> <p><i>*Note:</i> Wardrobe cabinets do not come equipped with coat rod and boot tray. Please specify separately. See page 420.</p> <p>File drawers include file bars for front to back and side to side filing.</p> <p>File drawers do not support bottom loading.</p> <p>Applicable finishes are listed on page 5 and 6.</p>

# Cabinets, 26 1/2" planning 64" high, wood interior

Reff Profiles

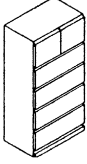
description	w	d	h	pattern no.	wood	wood	wood	wood
					interiors L	interiors V1	interiors V2	interiors V3
Cabinet with 4 files and (2) 15" doors at top 	30"	20"	64"	<b>RC632F-</b> ( ) ( ) ( )	\$2,914.	\$3,820.	\$4,393.	\$5,930.
	30"	24"	64"	<b>RC633F-</b> ( ) ( ) ( )	3,204.	4,198.	4,828.	6,517.
	36"	20"	64"	<b>RC662F-</b> ( ) ( ) ( )	3,204.	4,198.	4,828.	6,517.
	36"	24"	64"	<b>RC663F-</b> ( ) ( ) ( )	3,525.	4,622.	5,313.	7,173.

Requires two lock cores per cabinet  
Interior height clearance top drawer 10", all others 10 3/4"

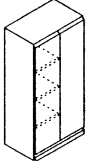
Cabinet with full height doors half wardrobe and half shelves 	30"	20"	64"	<b>RC632E(L/R)-</b> ( ) ( ) ( )	2,831.	3,710.	4,265.	5,758.
	30"	24"	64"	<b>RC633E(L/R)-</b> ( ) ( ) ( )	3,123.	4,095.	4,708.	6,355.
	36"	20"	64"	<b>RC662E(L/R)-</b> ( ) ( ) ( )	3,113.	4,078.	4,695.	6,338.
	36"	24"	64"	<b>RC663E(L/R)-</b> ( ) ( ) ( )	3,435.	4,506.	5,181.	6,995.

Requires one lock core per cabinet

Left hand shown

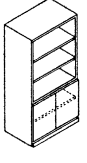
Cabinet with two open adjustable shelves, two hinged 22 1/2" doors 	30"	20"	64"	<b>RC632H-</b> ( ) ( ) ( )	2,204.	2,892.	3,325.	4,489.
	30"	24"	64"	<b>RC633H-</b> ( ) ( ) ( )	2,420.	3,172.	3,649.	4,926.
	36"	20"	64"	<b>RC662H-</b> ( ) ( ) ( )	2,420.	3,172.	3,649.	4,926.
	36"	24"	64"	<b>RC663H-</b> ( ) ( ) ( )	2,635.	3,456.	3,972.	5,362.

Requires one lock core per cabinet

Order Code	Specification Information	Application Notes
Example: <b>RC612LLWJN</b>	<i>To order please specify pattern number including:</i>	Key alike are field installed using the KnollKey order form. Random locks are factory installed.
<b>R</b> Reff	1. Hinge location, where applicable	<b>Cabinets do not come with lock included. Keying instructions must accompany all cabinet orders.</b>
<b>C</b> Cabinets	2. Finish type	
<b>6</b> 64" high	3. Interior option	Hinge door cabinets have optional lock drilling which can be specified in the cabinet product code.
<b>1</b> 16" wide	4. Pull option	<i>*Note:</i> Wardrobe cabinets do not come equipped with coat rod and boot tray. Please specify separately. See page 420.
<b>2</b> 20" deep	5. Lock option, where applicable	File drawers include file bars for front to back and side to side filing.
<b>L</b> Left hand hinge location	6. Finish, cabinet	File drawers do not support bottom loading.
<b>L</b> Laminate finish type	7. Finish, pull when applicable	Applicable finishes are listed on page 5 and 6.
<b>W</b> Wood interior	8. Keying instructions	
<b>J</b> Routed pull	<b>*After specifying product code, provide keying instructions.</b>	
<b>N</b> No lock drilling	1. <i>Hinge location:</i> L = Left hand R = Right hand	
	2. <i>Finish type:</i> L = Laminate 1 = V1 2 = V2 3 = V3	
	3. <i>Interior options:</i> W = Wood (shelves match case finish: L, V1, V2 or V3; drawer interiors cherry veneer)	
	4. <i>Pull options:</i> D = Metal D-pull J = Routed pull C = Nickel C-pull (nickel finish only) S = S-pull (stainless steel finish only)	
	5. <i>Lock options:</i> L = Lock hole drilled N = No lock drilling	
	8. Refer to page 523 for keying instructions.	
	Specify shelf paint finish on open cabinets with metal interiors.	
	Please note: Shelf adjustability is limited to approximately 2.5" up or down per shelf from predetermined shelf height.	

# Cabinets, 26 1/2" planning 64" high, wood interior

Reff Profiles

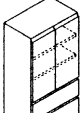
description	w	d	h	pattern no.	wood interiors L	wood interiors V1	wood interiors V2	wood interiors V3
Cabinet with hinged 37 1/2"H doors, two adjustable shelves, two file drawers 	16"	20"	64"	<b>RC612G(L/R)-( ) ( ) ( )</b>	\$2,242.	\$2,939.	\$3,380.	\$4,563.
	16"	24"	64"	<b>RC613G(L/R)-( ) ( ) ( )</b>	2,465.	3,228.	3,715.	5,014.
	30"	20"	64"	<b>RC632G-( ) ( ) ( )</b>	2,805.	3,676.	4,226.	5,705.
	30"	24"	64"	<b>RC633G-( ) ( ) ( )</b>	3,103.	4,067.	4,678.	6,316.
	36"	20"	64"	<b>RC662G-( ) ( ) ( )</b>	3,085.	4,042.	4,649.	6,277.
	36"	24"	64"	<b>RC663G-( ) ( ) ( )</b>	3,414.	4,474.	5,147.	6,950.

Requires two lock cores per cabinet

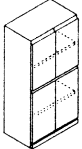
Cabinet with two sets of hinged doors, two pull-out shelves and ventilation Audio visual cabinet 	30"	20"	64"	<b>RC632I-( ) ( ) ( )</b>	3,090.	4,048.	4,656.	6,285.
	30"	24"	64"	<b>RC633I-( ) ( ) ( )</b>	3,400.	4,456.	5,128.	6,921.
	36"	20"	64"	<b>RC662I-( ) ( ) ( )</b>	3,304.	4,333.	4,982.	6,725.
	36"	24"	64"	<b>RC663I-( ) ( ) ( )</b>	3,616.	4,741.	5,449.	7,357.

Requires two lock cores per cabinet

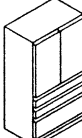
Cabinet with BBF below and hinged doors above 	16"	20"	64"	<b>RC612P(L/R)-( ) ( ) ( )</b>	2,310.	3,025.	3,478.	4,696.
	16"	24"	64"	<b>RC613P(L/R)-( ) ( ) ( )</b>	2,548.	3,339.	3,841.	5,186.
	30"	20"	64"	<b>RC632P-( ) ( ) ( )</b>	2,695.	3,532.	4,063.	5,484.
	30"	24"	64"	<b>RC633P-( ) ( ) ( )</b>	2,960.	3,879.	4,458.	6,018.
	36"	20"	64"	<b>RC662P-( ) ( ) ( )</b>	2,967.	3,885.	4,469.	6,034.
	36"	24"	64"	<b>RC663P-( ) ( ) ( )</b>	3,252.	4,268.	4,906.	6,622.

Requires two lock cores per cabinet

Order Code	Specification Information	Application Notes
Example: <b>RC612LLWJN</b>	<i>To order please specify pattern number including:</i>	Key alike are field installed using the KnollKey order form. Random locks are factory installed.
<b>R</b> Reff	1. Hinge location, where applicable	<b>Cabinets do not come with lock included. Keying instructions must accompany all cabinet orders.</b>
<b>C</b> Cabinets	2. Finish type	
<b>6</b> 64" high	3. Interior option	Hinge door cabinets have optional lock drilling which can be specified in the cabinet product code.
<b>1</b> 16" wide	4. Pull option	<i>*Note:</i> Wardrobe cabinets do not come equipped with coat rod and boot tray. Please specify separately. See page 420.
<b>2</b> 20" deep	5. Lock option, where applicable	File drawers include file bars for front to back and side to side filing.
<b>L</b> Left hand hinge location	6. Finish, cabinet	File drawers do not support bottom loading.
<b>L</b> Laminate finish type	7. Finish, pull when applicable	Applicable finishes are listed on page 5 and 6.
<b>W</b> Wood interior	8. Keying instructions	
<b>J</b> Routed pull	<b>*After specifying product code, provide keying instructions.</b>	
<b>N</b> No lock drilling	1. <i>Hinge location:</i> L = Left hand R = Right hand	
	2. <i>Finish type:</i> L = Laminate 1 = V1 2 = V2 3 = V3	
	3. <i>Interior options:</i> W = Wood (shelves match case finish: L, V1, V2 or V3; drawer interiors cherry veneer)	
	4. <i>Pull options:</i> D = Metal D-pull J = Routed pull C = Nickel C-pull (nickel finish only) S = S-pull (stainless steel finish only)	
	5. <i>Lock options:</i> L = Lock hole drilled N = No lock drilling	
	8. Refer to page 523 for keying instructions.	
	Specify shelf paint finish on open cabinets with metal interiors.	
	Please note: Shelf adjustability is limited to approximately 2.5" up or down per shelf from predetermined shelf height.	

# Cabinets, 26 1/2" planning 72" high, metal interiors

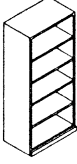
description	width	depth	height	pattern number	metal	metal	metal	metal
					interiors L	interiors V1	interiors V2	interiors V3
 Cabinet with open shelving	30"	20"	72"	<b>RC732B-()()</b>	\$1,865.	\$2,447.	\$2,814.	\$3,800.
	30"	24"	72"	<b>RC733B-()()</b>	2,068.	2,709.	3,118.	4,210.
	36"	20"	72"	<b>RC762B-()()</b>	2,111.	2,767.	3,182.	4,296.
	36"	24"	72"	<b>RC763B-()()</b>	2,314.	3,031.	3,487.	4,709.

Open cabinets require no keying instructions  
Shelves painted metal

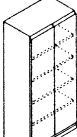
 Cabinet with hinged doors and shelves	16"	20"	72"	<b>RC712C(L/R)-()()()</b>	1,966.	2,576.	2,964.	4,002.
	16"	24"	72"	<b>RC713C(L/R)-()()()</b>	2,183.	2,861.	3,290.	4,440.
	30"	20"	72"	<b>RC732C-()()()</b>	2,566.	3,366.	3,870.	5,226.
	30"	24"	72"	<b>RC733C-()()()</b>	2,848.	3,731.	4,292.	5,794.
	36"	20"	72"	<b>RC762C-()()()</b>	2,837.	3,721.	4,278.	5,775.
	36"	24"	72"	<b>RC763C-()()()</b>	3,149.	4,123.	4,744.	6,405.

Requires one lock core per cabinet  
Shelves painted metal

Order Code	Specification Information	Application Notes
Example: <b>RC732BLMNN</b>	<i>To order please specify pattern number including:</i>	
<b>R</b> Reff	1. Hinge location, where applicable	1. Hinge location: L = Left hand R = Right hand
<b>C</b> Cabinets	2. Finish type	2. Finish type: L = Laminate 1 = V1 2 = V2 3 = V3
<b>7</b> 72" high	3. Interior option	3. Interior options: M = Metal (If laminate case finish-shelves painted to match; if V1, V2 or V3 case finish-shelves painted black; drawer interiors painted black metal)
<b>3</b> 30" wide	4. Pull option	4. Pull options: D = Metal D-pull J = Routed pull C = Nickel C-pull (nickel finish only) S = S-pull (stainless steel finish only)
<b>2</b> 20" deep	5. Lock option, where applicable	5. Lock options: L = Lock hole drilled N = No lock drilling
<b>B</b> Full bookcase	6. Finish, cabinet	10. Refer to page 523 for keying instructions.
<b>L</b> Laminate finish	7. Finish, pull when applicable	
<b>M</b> Metal interior	8. Left hand side of cabinet drilling: N = No drilling Size to drill for each workwall: S0 = 19"H x 15"D S1 = 19"H x 20"D T0 = 23"H x 15"D T1 = 23"H x 20"D	
<b>N</b> No drilling	9. Right hand side of cabinet drilling: same as #8 above.	
<b>N</b> No drilling	10. Keying instructions	

Please note: Shelf adjustability is limited to approximately 2.5" up or down per shelf from predetermined shelf height.

Order Code	Specification Information	Application Notes
Example: <b>RC732BLMNN</b>	<i>To order please specify pattern number including:</i>	
<b>R</b> Reff	1. Hinge location, where applicable	Key alike are field installed using the KnollKey order form. Random locks are factory installed.
<b>C</b> Cabinets	2. Finish type	<b>Cabinets do not come with lock included. Keying instructions must accompany all cabinet orders.</b>
<b>7</b> 72" high	3. Interior option	Hinge door cabinets have optional lock drilling which can be specified in the cabinet product code.
<b>3</b> 30" wide	4. Pull option	Wardrobe cabinets do not come equipped with coat rod and boot tray. Please specify separately. See page 420.
<b>2</b> 20" deep	5. Lock option, where applicable	File drawers include file bars for front to back and side to side filing.
<b>B</b> Full bookcase	6. Finish, cabinet	File drawers do not support bottom loading.
<b>L</b> Laminate finish	7. Finish, pull when applicable	For wall hung overhead compatibility, please refer page 352.
<b>M</b> Metal interior	8. Left hand side of cabinet drilling: N = No drilling Size to drill for each workwall: S0 = 19"H x 15"D S1 = 19"H x 20"D T0 = 23"H x 15"D T1 = 23"H x 20"D	Applicable finishes are listed on page 5 and 6.
<b>N</b> No drilling	9. Right hand side of cabinet drilling: same as #8 above.	
<b>N</b> No drilling	10. Keying instructions	



# Cabinets, 26 1/2" planning 72" high, metal interiors

description	width	depth	height	pattern number	metal	metal	metal	metal
					interiors L	interiors V1	interiors V2	interiors V3
Cabinet with full height doors, half wardrobe, and half shelves	30"	20"	72"	<b>RC732E(L/R)-( ) ( ) ( )</b>	\$3,018.	\$3,953.	\$4,550.	\$6,142.
	30"	24"	72"	<b>RC733E(L/R)-( ) ( ) ( )</b>	3,375.	4,422.	5,088.	6,868.
	36"	20"	72"	<b>RC762E(L/R)-( ) ( ) ( )</b>	3,308.	4,335.	4,985.	6,728.
	36"	24"	72"	<b>RC763E(L/R)-( ) ( ) ( )</b>	3,692.	4,845.	5,567.	7,517.

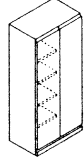

Left hand shown

Requires one lock core per cabinet  
Shelves painted metal

Order Code	Specification Information	Application Notes
Example: <b>RC732BLMNN</b>	<i>To order please specify pattern number including:</i>	
<b>R</b> Reff	1. Hinge location, where applicable	Key alike are field installed using the KnollKey order form. Random locks are factory installed.
<b>C</b> Cabinets	2. Finish type	<b>Cabinets do not come with lock included. Keying instructions must accompany all cabinet orders.</b>
<b>7</b> 72" high	3. Interior option	Hinge door cabinets have optional lock drilling which can be specified in the cabinet product code.
<b>3</b> 30" wide	4. Pull option	Wardrobe cabinets do not come equipped with coat rod and boot tray. Please specify separately. See page 420.
<b>2</b> 20" deep	5. Lock option, where applicable	File drawers include file bars for front to back and side to side filing.
<b>B</b> Full bookcase	6. Finish, cabinet	File drawers do not support bottom loading.
<b>L</b> Laminate finish	7. Finish, pull when applicable	For wall hung overhead compatibility, please refer page 352.
<b>M</b> Metal interior	8. Left hand side of cabinet drilling: N = No drilling Size to drill for each workwall: S0 = 19"H x 15"D S1 = 19"H x 20"D T0 = 23"H x 15"D T1 = 23"H x 20"D	Applicable finishes are listed on page 5 and 6.
<b>N</b> No drilling	9. Right hand side of cabinet drilling: same as #8 above.	
<b>N</b> No drilling	10. Keying instructions  *After specifying product code, provide keying instructions.	
	1. Hinge location: L = Left hand R = Right hand	
	2. Finish type: L = Laminate 1 = V1 2 = V2 3 = V3	
	3. Interior options: M = Metal (If laminate case finish-shelves painted to match; if V1, V2 or V3 case finish-shelves painted black; drawer interiors painted black metal)	
	4. Pull options: D = Metal D-pull J = Routed pull C = Nickel C-pull (nickel finish only) S = S-pull (stainless steel finish only)	
	5. Lock options: L = Lock hole drilled N = No lock drilling	
	10. Refer to page 523 for keying instructions.	

Please note: Shelf adjustability is limited to approximately 2.5" up or down per shelf from predetermined shelf height.

# Cabinets, 26 1/2" planning 72" high, metal interiors

description	width	depth	height	pattern number	metal interiors L	metal interiors V1	metal interiors V2	metal interiors V3
Cabinet with four files and hinged doors above.	30"	20"	72"	<b>RC732F-</b> ( ) ( ) ( )	\$3,065.	\$4,016.	\$4,620.	\$6,235.
	30"	24"	72"	<b>RC733F-</b> ( ) ( ) ( )	3,405.	4,461.	5,131.	6,926.
	36"	20"	72"	<b>RC762F-</b> ( ) ( ) ( )	3,385.	4,436.	5,100.	6,886.
	36"	24"	72"	<b>RC763F-</b> ( ) ( ) ( )	3,757.	4,927.	5,664.	7,646.

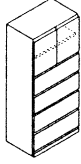

Requires two lock cores per cabinet  
interior height clearance top drawer 10", all others 10 3/4"  
Shelves painted metal

Order Code	Specification Information	Application Notes
Example: <b>RC732BLMNN</b>	<i>To order please specify pattern number including:</i>	
<b>R</b> Reff	1. Hinge location, where applicable	1. Hinge location: L = Left hand R = Right hand
<b>C</b> Cabinets	2. Finish type	2. Finish type: L = Laminate 1 = V1 2 = V2 3 = V3
<b>7</b> 72" high	3. Interior option	3. Interior options: M = Metal (If laminate case finish-shelves painted to match; if V1, V2 or V3 case finish-shelves painted black; drawer interiors painted black metal)
<b>3</b> 30" wide	4. Pull option	4. Pull options: D = Metal D-pull J = Routed pull C = Nickel C-pull (nickel finish only) S = S-pull (stainless steel finish only)
<b>2</b> 20" deep	5. Lock option, where applicable	5. Lock options: L = Lock hole drilled N = No lock drilling
<b>B</b> Full bookcase	6. Finish, cabinet	10. Refer to page 523 for keying instructions.
<b>L</b> Laminate finish	7. Finish, pull when applicable	
<b>M</b> Metal interior	8. Left hand side of cabinet drilling: N = No drilling Size to drill for each workwall: S0 = 19"H x 15"D S1 = 19"H x 20"D T0 = 23"H x 15"D T1 = 23"H x 20"D	
<b>N</b> No drilling	9. Right hand side of cabinet drilling: same as #8 above.	
<b>N</b> No drilling	10. Keying instructions	

Please note: Shelf adjustability is limited to approximately 2.5" up or down per shelf from predetermined shelf height.

# Cabinets, 26 1/2" planning 72" high, metal interiors

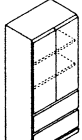
description	width	depth	height	pattern number	metal	metal	metal	metal
					interiors L	interiors V1	interiors V2	interiors V3
 Cabinet with two files and hinged doors above	16"	20"	72"	<b>RC712G(L/R)-( ) ( ) ( )</b>	\$2,227.	\$2,916.	\$3,356.	\$4,530.
	16"	24"	72"	<b>RC713G(L/R)-( ) ( ) ( )</b>	2,440.	3,236.	3,722.	5,023.
	30"	20"	72"	<b>RC732G-( ) ( ) ( )</b>	2,826.	3,706.	4,260.	5,752.
	30"	24"	72"	<b>RC733G-( ) ( ) ( )</b>	3,108.	4,073.	4,682.	6,322.
	36"	20"	72"	<b>RC762G-( ) ( ) ( )</b>	3,070.	4,022.	4,628.	6,247.
	36"	24"	72"	<b>RC763G-( ) ( ) ( )</b>	3,352.	4,394.	5,053.	6,821.

Requires two lock cores per cabinet  
Shelves painted metal

### Order Code

Example:	<b>RC732BLMNN</b>
<b>R</b>	Reff
<b>C</b>	Cabinets
<b>7</b>	72" high
<b>3</b>	30" wide
<b>2</b>	20" deep
<b>B</b>	Full bookcase
<b>L</b>	Laminate finish
<b>M</b>	Metal interior
<b>N</b>	No drilling
<b>N</b>	No drilling

Please note: Shelf adjustability is limited to approximately 2.5" up or down per shelf from predetermined shelf height.

### Specification Information

To order please specify pattern number including:

- Hinge location, where applicable
- Finish type
- Interior option
- Pull option
- Lock option, where applicable
- Finish, cabinet
- Finish, pull when applicable
- Left hand side of cabinet drilling:  
N = No drilling  
Size to drill for each workwall:  
S0 = 19"H x 15"D  
S1 = 19"H x 20"D  
T0 = 23"H x 15"D  
T1 = 23"H x 20"D
- Right hand side of cabinet drilling: same as #8 above.
- Keying instructions

\*After specifying product code, provide keying instructions.

1. Hinge location:  
L = Left hand  
R = Right hand

2. Finish type:  
L = Laminate  
1 = V1  
2 = V2  
3 = V3

3. Interior options:  
M = Metal (If laminate case finish-shelves painted to match; if V1, V2 or V3 case finish-shelves painted black; drawer interiors painted black metal)

4. Pull options:  
D = Metal D-pull  
J = Routed pull  
C = Nickel C-pull (nickel finish only)  
S = S-pull (stainless steel finish only)

5. Lock options:  
L = Lock hole drilled  
N = No lock drilling

10. Refer to page 523 for keying instructions.

### Application Notes

Key alike are field installed using the KnollKey order form. Random locks are factory installed.

**Cabinets do not come with lock included. Keying instructions must accompany all cabinet orders.**

Hinge door cabinets have optional lock drilling which can be specified in the cabinet product code.

Wardrobe cabinets do not come equipped with coat rod and boot tray. Please specify separately. See page 420.

File drawers include file bars for front to back and side to side filing.

File drawers do not support bottom loading.

For wall hung overhead compatibility, please refer page 352.

Applicable finishes are listed on page 5 and 6.

# Cabinets, 26 1/2" planning 72" high, metal interiors

description	width	depth	height	pattern number	metal	metal	metal	metal
					interiors L	interiors V1	interiors V2	interiors V3
Cabinet with hinged doors below and open shelf above.	30"	20"	72"	<b>RC732H-()()()</b>	\$2,465.	\$3,227.	\$3,713.	\$5,012.
	30"	24"	72"	<b>RC733H-()()()</b>	2,725.	3,567.	4,102.	5,539.
	36"	20"	72"	<b>RC762H-()()()</b>	2,708.	3,547.	4,077.	5,505.
	36"	24"	72"	<b>RC763H-()()()</b>	2,970.	3,886.	4,470.	6,035.

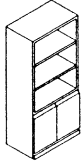

Requires one lock core per cabinet  
Shelves painted metal

Cabinet with BBF below and hinged doors above.	16"	20"	72"	<b>RC712P(L/R)-()()()</b>	2,312.	3,027.	3,482.	4,702.
	16"	24"	72"	<b>RC713P(L/R)-()()()</b>	2,548.	3,339.	3,841.	5,186.
	30"	20"	72"	<b>RC732P-()()()</b>	2,728.	3,574.	4,112.	5,552.
	30"	24"	72"	<b>RC733P-()()()</b>	3,009.	3,945.	4,536.	6,123.
	36"	20"	72"	<b>RC762P-()()()</b>	3,015.	3,950.	4,541.	6,131.
	36"	24"	72"	<b>RC763P-()()()</b>	3,326.	4,355.	5,010.	6,764.

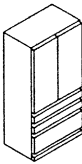

Requires two lock cores per cabinet  
Shelves and drawer interiors metal

Order Code	Specification Information	Application Notes
Example: <b>RC732BLMNN</b>	<i>To order please specify pattern number including:</i>	
<b>R</b> Reff	1. Hinge location, where applicable	1. Hinge location: L = Left hand R = Right hand
<b>C</b> Cabinets	2. Finish type	2. Finish type: L = Laminate 1 = V1 2 = V2 3 = V3
<b>7</b> 72" high	3. Interior option	3. Interior options: M = Metal (If laminate case finish-shelves painted to match; if V1, V2 or V3 case finish-shelves painted black; drawer interiors painted black metal)
<b>3</b> 30" wide	4. Pull option	4. Pull options: D = Metal D-pull J = Routed pull C = Nickel C-pull (nickel finish only) S = S-pull (stainless steel finish only)
<b>2</b> 20" deep	5. Lock option, where applicable	5. Lock options: L = Lock hole drilled N = No lock drilling
<b>B</b> Full bookcase	6. Finish, cabinet	10. Refer to page 523 for keying instructions.
<b>L</b> Laminate finish	7. Finish, pull when applicable	
<b>M</b> Metal interior	8. Left hand side of cabinet drilling: N = No drilling Size to drill for each workwall: S0 = 19"H x 15"D S1 = 19"H x 20"D T0 = 23"H x 15"D T1 = 23"H x 20"D	
<b>N</b> No drilling	9. Right hand side of cabinet drilling: same as #8 above.	
<b>N</b> No drilling	10. Keying instructions	

Please note: Shelf adjustability is limited to approximately 2.5" up or down per shelf from predetermined shelf height.

# Cabinets, 26 1/2" planning 72" high, wood interiors

Reff Profiles

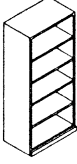
description	w	d	h	pattern no.	wood interiors L	wood interiors V1	wood interiors V2	wood interiors V3
 Cabinet with open shelving	30"	20"	72"	<b>RC732B-</b> ( ) ( )	\$2,005.	\$2,629.	\$3,023.	\$4,080.
	30"	24"	72"	<b>RC733B-</b> ( ) ( )	2,207.	2,895.	3,327.	4,492.
	36"	20"	72"	<b>RC762B-</b> ( ) ( )	2,252.	2,951.	3,393.	4,580.
	36"	24"	72"	<b>RC763B-</b> ( ) ( )	2,453.	3,216.	3,697.	4,992.

Open cabinets require no keying instructions

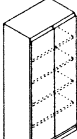
 Cabinet with hinged doors and shelves	16"	20"	72"	<b>RC712C(L/R)-</b> ( ) ( ) ( )	2,108.	2,760.	3,174.	4,285.
	16"	24"	72"	<b>RC713C(L/R)-</b> ( ) ( ) ( )	2,322.	3,045.	3,500.	4,724.
	30"	20"	72"	<b>RC732C-</b> ( ) ( ) ( )	2,707.	3,547.	4,077.	5,505.
	30"	24"	72"	<b>RC733C-</b> ( ) ( ) ( )	2,988.	3,917.	4,505.	6,081.
	36"	20"	72"	<b>RC762C-</b> ( ) ( ) ( )	2,976.	3,902.	4,488.	6,058.
	36"	24"	72"	<b>RC763C-</b> ( ) ( ) ( )	3,289.	4,310.	4,955.	6,690.

Requires one lock core per cabinet

Cabinetry

Order Code	Specification Information	Application Notes	
Example: <b>RC732BLWNN</b> <b>R</b> Reff <b>C</b> Cabinets <b>7</b> 72" high <b>3</b> 30" wide <b>2</b> 20" deep <b>B</b> Full bookcase <b>L</b> Laminate finish <b>W</b> Wood interior <b>N</b> No drilling <b>N</b> No drilling	<i>To order please specify pattern number including:</i> <ol style="list-style-type: none"> <li>Hinge location, where applicable</li> <li>Finish type</li> <li>Interior option</li> <li>Pull option</li> <li>Lock option, where applicable</li> <li>Finish, cabinet</li> <li>Finish, pull when applicable</li> <li>Left hand side of cabinet drilling: N = No drilling Size to drill for each workwall: S0 = 19"H x 15"D S1 = 19"H x 20"D T0 = 23"H x 15"D T1 = 23"H x 20"D</li> <li>Right hand side of cabinet drilling: same as #8 above.</li> <li>Keying instructions</li> </ol> *After specifying product code, provide keying instructions.	<ol style="list-style-type: none"> <li><i>Hinge location:</i> L = Left hand R = Right hand</li> <li><i>Finish type:</i> L = Laminate 1 = V1 2 = V2 3 = V3</li> <li><i>Interior options:</i> W = Wood (shelves match case finish: L,V1,V2 or V3; drawer interiors cherry veneer)</li> <li><i>Pull options:</i> D = Metal D-pull J = Routed pull C = Nickel C-pull (nickel finish only) S = S-pull (stainless steel finish only)</li> <li><i>Lock options:</i> L = Lock hole drilled N = No lock drilling</li> <li>10. Refer to page 523 for keying instructions.</li> </ol>	Key alike are field installed using the KnollKey order form. Random locks are factory installed.  <b>Cabinets do not come with lock included. Keying instructions must accompany all cabinet orders.</b>  Hinge door cabinets have optional lock drilling which can be specified in the cabinet product code.  Wardrobe cabinets do not come equipped with coat rod and boot tray. Please specify separately. See page 420.  File drawers include file bars for front to back and side to side filing.  File drawers do not support bottom loading.  Applicable finishes are listed on page 5 and 6.

Please note: Shelf adjustability is limited to approximately 2.5" up or down per shelf from predetermined shelf height.

# Cabinets, 26 1/2" planning 72" high, wood interiors

description	w	d	h	pattern no.	wood	wood	wood	wood
					interiors L	interiors V1	interiors V2	interiors V3
Cabinet with full height doors, half wardrobe, and half shelves	30"	20"	72"	<b>RC732E(L/R)-( ) ( ) ( )</b>	\$3,156.	\$4,138.	\$4,758.	\$6,423.
	30"	24"	72"	<b>RC733E(L/R)-( ) ( ) ( )</b>	3,514.	4,607.	5,298.	7,151.
	36"	20"	72"	<b>RC762E(L/R)-( ) ( ) ( )</b>	3,448.	4,518.	5,197.	7,017.
	36"	24"	72"	<b>RC763E(L/R)-( ) ( ) ( )</b>	3,835.	5,026.	5,781.	7,804.

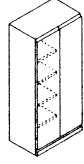

Left hand shown

Requires one lock core per cabinet

## Order Code

Example:	<b>RC732BLWNN</b>
<b>R</b>	Reff
<b>C</b>	Cabinets
<b>7</b>	72" high
<b>3</b>	30" wide
<b>2</b>	20" deep
<b>B</b>	Full bookcase
<b>L</b>	Laminate finish
<b>W</b>	Wood interior
<b>N</b>	No drilling
<b>N</b>	No drilling

Please note: Shelf adjustability is limited to approximately 2.5" up or down per shelf from predetermined shelf height.

## Specification Information

To order please specify pattern number including:

- Hinge location, where applicable
- Finish type
- Interior option
- Pull option
- Lock option, where applicable
- Finish, cabinet
- Finish, pull when applicable
- Left hand side of cabinet drilling:  
N = No drilling  
Size to drill for each workwall:  
S0 = 19"H x 15"D  
S1 = 19"H x 20"D  
T0 = 23"H x 15"D  
T1 = 23"H x 20"D
- Right hand side of cabinet drilling: same as #8 above.
- Keying instructions

\*After specifying product code, provide keying instructions.

### 1. Hinge location:

L = Left hand  
R = Right hand

### 2. Finish type:

L = Laminate  
1 = V1  
2 = V2  
3 = V3

### 3. Interior options:

W = Wood (shelves match case finish: L, V1, V2 or V3; drawer interiors cherry veneer)

### 4. Pull options:

D = Metal D-pull  
J = Routed pull  
C = Nickel C-pull (nickel finish only)  
S = S-pull (stainless steel finish only)

### 5. Lock options:

L = Lock hole drilled  
N = No lock drilling

10. Refer to page 523 for keying instructions.

## Application Notes

Key alike are field installed using the KnollKey order form. Random locks are factory installed.

**Cabinets do not come with lock included. Keying instructions must accompany all cabinet orders.**

Hinge door cabinets have optional lock drilling which can be specified in the cabinet product code.

Wardrobe cabinets do not come equipped with coat rod and boot tray. Please specify separately. See page 420.

File drawers include file bars for front to back and side to side filing.

File drawers do not support bottom loading.

Applicable finishes are listed on page 5 and 6.

# Cabinets, 26 1/2" planning 72" high, wood interiors

description	w	d	h	pattern no.	wood	wood	wood	wood
					interiors L	interiors V1	interiors V2	interiors V3
Cabinet with four files and hinged doors above.	30"	20"	72"	<b>RC732F-</b> ( ) ( ) ( )	\$3,204.	\$4,198.	\$4,828.	\$6,517.
	30"	24"	72"	<b>RC733F-</b> ( ) ( ) ( )	3,545.	4,645.	5,340.	7,209.
	36"	20"	72"	<b>RC762F-</b> ( ) ( ) ( )	3,525.	4,622.	5,327.	7,191.
	36"	24"	72"	<b>RC763F-</b> ( ) ( ) ( )	3,896.	5,108.	5,877.	7,935.

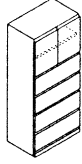

Requires two lock cores per cabinet  
interior height clearance top drawer 10", all others 10 3/4"

Order Code	Specification Information	Application Notes
Example: <b>RC732BLWNN</b>	<i>To order please specify pattern number including:</i>	
<b>R</b> Reff	1. Hinge location, where applicable	Key alike are field installed using the KnollKey order form. Random locks are factory installed.
<b>C</b> Cabinets	2. Finish type	<b>Cabinets do not come with lock included. Keying instructions must accompany all cabinet orders.</b>
<b>7</b> 72" high	3. Interior option	Hinge door cabinets have optional lock drilling which can be specified in the cabinet product code.
<b>3</b> 30" wide	4. Pull option	Wardrobe cabinets do not come equipped with coat rod and boot tray. Please specify separately. See page 420.
<b>2</b> 20" deep	5. Lock option, where applicable	File drawers include file bars for front to back and side to side filing.
<b>B</b> Full bookcase	6. Finish, cabinet	File drawers do not support bottom loading.
<b>L</b> Laminate finish	7. Finish, pull when applicable	Applicable finishes are listed on page 5 and 6.
<b>W</b> Wood interior	8. Left hand side of cabinet drilling: N = No drilling Size to drill for each workwall: S0 = 19"H x 15"D S1 = 19"H x 20"D T0 = 23"H x 15"D T1 = 23"H x 20"D	
<b>N</b> No drilling	9. Right hand side of cabinet drilling: same as #8 above.	
<b>N</b> No drilling	10. Keying instructions  *After specifying product code, provide keying instructions.	
	1. <i>Hinge location:</i> L = Left hand R = Right hand	
	2. <i>Finish type:</i> L = Laminate 1 = V1 2 = V2 3 = V3	
	3. <i>Interior options:</i> W = Wood (shelves match case finish: L,V1,V2 or V3; drawer interiors cherry veneer)	
	4. <i>Pull options:</i> D = Metal D-pull J = Routed pull C = Nickel C-pull (nickel finish only) S = S-pull (stainless steel finish only)	
	5. <i>Lock options:</i> L = Lock hole drilled N = No lock drilling	
	10. Refer to page 523 for keying instructions.	

Please note: Shelf adjustability is limited to approximately 2.5" up or down per shelf from predetermined shelf height.

# Cabinets, 26 1/2" planning 72" high, wood interiors

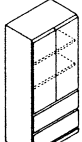
description	w	d	h	pattern no.	wood	wood	wood	wood
					interiors L	interiors V1	interiors V2	interiors V3
 Cabinet with two files and hinged doors above	16"	20"	72"	<b>RC712G(L/R)-( ) ( ) ( )</b>	\$2,367.	\$3,102.	\$3,567.	\$4,814.
	16"	24"	72"	<b>RC713G(L/R)-( ) ( ) ( )</b>	2,609.	3,419.	3,931.	5,307.
	30"	20"	72"	<b>RC732G-( ) ( ) ( )</b>	2,968.	3,886.	4,470.	6,035.
	30"	24"	72"	<b>RC733G-( ) ( ) ( )</b>	3,247.	4,257.	4,893.	6,607.
	36"	20"	72"	<b>RC762G-( ) ( ) ( )</b>	3,210.	4,207.	4,838.	6,531.
	36"	24"	72"	<b>RC763G-( ) ( ) ( )</b>	3,494.	4,579.	5,265.	7,107.

Requires two lock cores per cabinet

Order Code	Specification Information	Application Notes	
Example: <b>RC732BLWNN</b> <b>R</b> Reff <b>C</b> Cabinets <b>7</b> 72" high <b>3</b> 30" wide <b>2</b> 20" deep <b>B</b> Full bookcase <b>L</b> Laminate finish <b>W</b> Wood interior <b>N</b> No drilling <b>N</b> No drilling	<i>To order please specify pattern number including:</i> 1. Hinge location, where applicable 2. Finish type 3. Interior option 4. Pull option 5. Lock option, where applicable 6. Finish, cabinet 7. Finish, pull when applicable 8. Left hand side of cabinet drilling: N = No drilling Size to drill for each workwall: S0 = 19"H x 15"D S1 = 19"H x 20"D T0 = 23"H x 15"D T1 = 23"H x 20"D 9. Right hand side of cabinet drilling: same as #8 above. 10. Keying instructions  *After specifying product code, provide keying instructions.	1. <i>Hinge location:</i> L = Left hand R = Right hand  2. <i>Finish type:</i> L = Laminate 1 = V1 2 = V2 3 = V3  3. <i>Interior options:</i> W = Wood (shelves match case finish: L,V1,V2 or V3; drawer interiors cherry veneer)  4. <i>Pull options:</i> D = Metal D-pull J = Routed pull C = Nickel C-pull (nickel finish only) S = S-pull (stainless steel finish only)  5. <i>Lock options:</i> L = Lock hole drilled N = No lock drilling  10. Refer to page 523 for keying instructions.	Key alike are field installed using the KnollKey order form. Random locks are factory installed.  <b>Cabinets do not come with lock included. Keying instructions must accompany all cabinet orders.</b>  Hinge door cabinets have optional lock drilling which can be specified in the cabinet product code.  Wardrobe cabinets do not come equipped with coat rod and boot tray. Please specify separately. See page 420.  File drawers include file bars for front to back and side to side filing.  File drawers do not support bottom loading.  Applicable finishes are listed on page 5 and 6.

Please note: Shelf adjustability is limited to approximately 2.5" up or down per shelf from predetermined shelf height.



# Cabinets, 26 1/2" planning 72" high, wood interiors

description	w	d	h	pattern no.	wood interiors L	wood interiors V1	wood interiors V2	wood interiors V3
Cabinet with hinged doors below and open shelf above.	30"	20"	72"	<b>RC732H-( ) ( ) ( )</b>	\$2,599.	\$3,408.	\$3,921.	\$5,292.
	30"	24"	72"	<b>RC733H-( ) ( ) ( )</b>	2,858.	3,749.	4,311.	5,820.
	36"	20"	72"	<b>RC762H-( ) ( ) ( )</b>	2,845.	3,726.	4,286.	5,786.
	36"	24"	72"	<b>RC763H-( ) ( ) ( )</b>	3,103.	4,067.	4,678.	6,316.

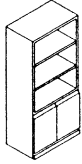

Requires one lock core per cabinet

Wardrobe cabinet	w	d	h	pattern no.	wood interiors L	wood interiors V1	wood interiors V2	wood interiors V3
	16"	20"	72"	<b>RC712D(L/R)-( ) ( ) ( )</b>	1,770.	2,322.	2,670.	3,604.
	16"	24"	72"	<b>RC713D(L/R)-( ) ( ) ( )</b>	1,949.	2,554.	2,936.	3,964.
	30"	20"	72"	<b>RC732D-( ) ( ) ( )</b>	2,230.	2,923.	3,359.	4,535.
	30"	24"	72"	<b>RC733D-( ) ( ) ( )</b>	2,450.	3,211.	3,693.	4,987.
	36"	20"	72"	<b>RC762D-( ) ( ) ( )</b>	2,451.	3,214.	3,696.	4,991.
	36"	24"	72"	<b>RC763D-( ) ( ) ( )</b>	2,695.	3,532.	4,063.	5,484.

Requires one lock core per cabinet.

Order coat rod and boot tray from accessories

Order Code	Specification Information	Application Notes	
<p>Example: <b>RC732BLWNN</b></p> <p><b>R</b> Reff</p> <p><b>C</b> Cabinets</p> <p><b>7</b> 72" high</p> <p><b>3</b> 30" wide</p> <p><b>2</b> 20" deep</p> <p><b>B</b> Full bookcase</p> <p><b>L</b> Laminate finish</p> <p><b>W</b> Wood interior</p> <p><b>N</b> No drilling</p> <p><b>N</b> No drilling</p>	<p><i>To order please specify pattern number including:</i></p> <ol style="list-style-type: none"> <li>Hinge location, where applicable</li> <li>Finish type</li> <li>Interior option</li> <li>Pull option</li> <li>Lock option, where applicable</li> <li>Finish, cabinet</li> <li>Finish, pull when applicable</li> <li>Left hand side of cabinet drilling: N = No drilling Size to drill for each workwall: S0 = 19"H x 15"D S1 = 19"H x 20"D T0 = 23"H x 15"D T1 = 23"H x 20"D</li> <li>Right hand side of cabinet drilling: same as #8 above.</li> <li>Keying instructions</li> </ol> <p>*After specifying product code, provide keying instructions.</p>	<p>1. <i>Hinge location:</i> L = Left hand R = Right hand</p> <p>2. <i>Finish type:</i> L = Laminate 1 = V1 2 = V2 3 = V3</p> <p>3. <i>Interior options:</i> W = Wood (shelves match case finish: L, V1, V2 or V3; drawer interiors cherry veneer)</p> <p>4. <i>Pull options:</i> D = Metal D-pull J = Routed pull C = Nickel C-pull (nickel finish only) S = S-pull (stainless steel finish only)</p> <p>5. <i>Lock options:</i> L = Lock hole drilled N = No lock drilling</p> <p>10. Refer to page 523 for keying instructions.</p>	<p>Key alike are field installed using the KnollKey order form. Random locks are factory installed.</p> <p><b>Cabinets do not come with lock included. Keying instructions must accompany all cabinet orders.</b></p> <p>Hinge door cabinets have optional lock drilling which can be specified in the cabinet product code.</p> <p>Wardrobe cabinets do not come equipped with coat rod and boot tray. Please specify separately. See page 420.</p> <p>File drawers include file bars for front to back and side to side filing.</p> <p>File drawers do not support bottom loading.</p> <p>Applicable finishes are listed on page 5 and 6.</p>

Please note: Shelf adjustability is limited to approximately 2.5" up or down per shelf from predetermined shelf height.

# Cabinets, 26 1/2" planning 72" high, wood interiors

description	w	d	h	pattern no.	wood interiors L	wood interiors V1	wood interiors V2	wood interiors V3
Audio visual cabinet with two sets of hinged doors, two pull out shelves and ventilation	30"	20"	72"	<b>RC732I-</b> ( ) ( ) ( )	\$3,424.	\$4,486.	\$5,158.	\$6,964.
	30"	24"	72"	<b>RC733I-</b> ( ) ( ) ( )	3,778.	4,953.	5,698.	7,691.
	36"	20"	72"	<b>RC762I-</b> ( ) ( ) ( )	3,714.	4,868.	5,600.	7,560.
	36"	24"	72"	<b>RC763I-</b> ( ) ( ) ( )	4,100.	5,376.	6,183.	8,346.



Requires two lock cores per cabinet  
Hinge opening 110°

description	w	d	h	pattern no.	wood interiors L	wood interiors V1	wood interiors V2	wood interiors V3
Cabinet with BBF below and hinged doors above	16"	20"	72"	<b>RC712P(L/R)-</b> ( ) ( ) ( )	2,450.	3,211.	3,693.	4,987.
	16"	24"	72"	<b>RC713P(L/R)-</b> ( ) ( ) ( )	2,688.	3,524.	4,051.	5,471.
	30"	20"	72"	<b>RC732P-</b> ( ) ( ) ( )	2,870.	3,761.	4,324.	5,838.
	30"	24"	72"	<b>RC733P-</b> ( ) ( ) ( )	3,150.	4,127.	4,745.	6,407.
	36"	20"	72"	<b>RC762P-</b> ( ) ( ) ( )	3,154.	4,133.	4,753.	6,417.
	36"	24"	72"	<b>RC763P-</b> ( ) ( ) ( )	3,465.	4,540.	5,221.	7,050.

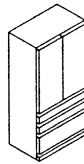

Requires two lock cores per cabinet

Order Code	Specification Information	Application Notes
Example: <b>RC732BLWNN</b>	<i>To order please specify pattern number including:</i>	
<b>R</b> Reff	1. Hinge location, where applicable	Key alike are field installed using the KnollKey order form. Random locks are factory installed.
<b>C</b> Cabinets	2. Finish type	<b>Cabinets do not come with lock included. Keying instructions must accompany all cabinet orders.</b>
<b>7</b> 72" high	3. Interior option	Hinge door cabinets have optional lock drilling which can be specified in the cabinet product code.
<b>3</b> 30" wide	4. Pull option	Wardrobe cabinets do not come equipped with coat rod and boot tray. Please specify separately. See page 420.
<b>2</b> 20" deep	5. Lock option, where applicable	File drawers include file bars for front to back and side to side filing.
<b>B</b> Full bookcase	6. Finish, cabinet	File drawers do not support bottom loading.
<b>L</b> Laminate finish	7. Finish, pull when applicable	Applicable finishes are listed on page 5 and 6.
<b>W</b> Wood interior	8. Left hand side of cabinet drilling: N = No drilling Size to drill for each workwall: S0 = 19"H x 15"D S1 = 19"H x 20"D T0 = 23"H x 15"D T1 = 23"H x 20"D	
<b>N</b> No drilling	9. Right hand side of cabinet drilling: same as #8 above.	
<b>N</b> No drilling	10. Keying instructions  *After specifying product code, provide keying instructions.	
	1. <i>Hinge location:</i> L = Left hand R = Right hand	
	2. <i>Finish type:</i> L = Laminate 1 = V1 2 = V2 3 = V3	
	3. <i>Interior options:</i> W = Wood (shelves match case finish: L,V1,V2 or V3; drawer interiors cherry veneer)	
	4. <i>Pull options:</i> D = Metal D-pull J = Routed pull C = Nickel C-pull (nickel finish only) S = S-pull (stainless steel finish only)	
	5. <i>Lock options:</i> L = Lock hole drilled N = No lock drilling	
	10. Refer to page 523 for keying instructions.	

Please note: Shelf adjustability is limited to approximately 2.5" up or down per shelf from predetermined shelf height.

# Cabinets, 26 1/2" planning

## Freestanding Multifunction Cabinets

### 49", 64" and 72" high metal interiors

description	type	w	d	h	pattern no.	metal	metal	metal	metal
						interiors L	interiors V1	interiors V2	interiors V3
Freestanding multifunctional cabinet, 49"h	Box/Box/File	24"	24"	49"	<b>RC423N</b> (X)(X)(X)	\$2,913.	\$3,978.	\$4,603.	\$5,523.
	File/File	24"	24"	49"	<b>RC423M</b> (X)(X)(X)	2,722.	3,778.	4,377.	5,253.

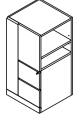

Freestanding multifunctional cabinet, 64"h	Box/Box/File	24"	24"	64"	<b>RC623N</b> (X)(X)(X)	3,125.	4,307.	5,070.	6,084.
	File/File	24"	24"	64"	<b>RC623M</b> (X)(X)(X)	2,932.	4,107.	4,873.	5,848.

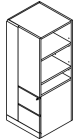

Order Code	Specification Information	Application Notes
Example: <b>RC732BLMNN</b>	<i>To order please specify pattern number including:</i>	
<b>R</b> Reff	1. Hinge location, where applicable	1. Hinge location: L = Left hand R = Right hand
<b>C</b> Cabinets	2. Finish type	2. Finish type: L = Laminate 1 = V1 2 = V2 3 = V3
<b>7</b> 72" high	3. Interior option	3. Interior options: M = Metal (If laminate case finish-shelves painted to match; if V1, V2 or V3 case finish-shelves painted black; drawer interiors painted black metal)
<b>3</b> 30" wide	4. Pull option	4. Pull options: D = Metal D-pull J = Routed pull C = Nickel C-pull (nickel finish only) S = S-pull (stainless steel finish only)
<b>2</b> 20" deep	5. Lock option, where applicable	5. Lock options: L = Lock hole drilled N = No lock drilling
<b>B</b> Full bookcase	6. Finish, cabinet	10. Refer to page 523 for keying instructions.
<b>L</b> Laminate finish	7. Finish, pull when applicable	
<b>M</b> Metal interior	8. Left hand side of cabinet drilling: N = No drilling Size to drill for each workwall: S0 = 19"H x 15"D S1 = 19"H x 20"D T0 = 23"H x 15"D T1 = 23"H x 20"D	
<b>N</b> No drilling	9. Right hand side of cabinet drilling: same as #8 above.	
<b>N</b> No drilling	10. Keying instructions  *After specifying product code, provide keying instructions.	

Please note: Shelf adjustability is limited to approximately 2.5" up or down per shelf from predetermined shelf height.

# Cabinets, 26 1/2" planning

## Freestanding Multifunction Cabinets

### 49", 64" and 72" high metal interiors

description	type	w	d	h	pattern no.	metal	metal	metal	metal
						interiors L	interiors V1	interiors V2	interiors V3
Freestanding multifunctional cabinet, 72"h	Box/Box/File	24"	24"	72"	<b>RC723N</b> ( ) ( ) ( )	\$3,273.	\$4,516.	\$5,358.	\$6,429.
	File/File	24"	24"	72"	<b>RC723M</b> ( ) ( ) ( )	3,081.	4,315.	5,154.	6,184.

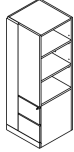

Order Code	Specification Information	Application Notes
Example: <b>RC732BLMNN</b>	<i>To order please specify pattern number including:</i>	
<b>R</b> Reff	1. Hinge location, where applicable	Key alike are field installed using the KnollKey order form. Random locks are factory installed.
<b>C</b> Cabinets	2. Finish type	<b>Cabinets do not come with lock included. Keying instructions must accompany all cabinet orders.</b>
<b>7</b> 72" high	3. Interior option	Hinge door cabinets have optional lock drilling which can be specified in the cabinet product code.
<b>3</b> 30" wide	4. Pull option	Wardrobe cabinets do not come equipped with coat rod and boot tray. Please specify separately. See page 420.
<b>2</b> 20" deep	5. Lock option, where applicable	File drawers include file bars for front to back and side to side filing.
<b>B</b> Full bookcase	6. Finish, cabinet	File drawers do not support bottom loading.
<b>L</b> Laminate finish	7. Finish, pull when applicable	Applicable finishes are listed on page 5 and 6.
<b>M</b> Metal interior	8. Left hand side of cabinet drilling: N = No drilling Size to drill for each workwall: S0 = 19"H x 15"D S1 = 19"H x 20"D T0 = 23"H x 15"D T1 = 23"H x 20"D	
<b>N</b> No drilling	9. Right hand side of cabinet drilling: same as #8 above.	
<b>N</b> No drilling	10. Keying instructions  *After specifying product code, provide keying instructions.	
	1. Hinge location: L = Left hand R = Right hand	
	2. Finish type: L = Laminate 1 = V1 2 = V2 3 = V3	
	3. Interior options: M = Metal (If laminate case finish-shelves painted to match; if V1, V2 or V3 case finish-shelves painted black; drawer interiors painted black metal)	
	4. Pull options: D = Metal D-pull J = Routed pull C = Nickel C-pull (nickel finish only) S = S-pull (stainless steel finish only)	
	5. Lock options: L = Lock hole drilled N = No lock drilling	
	10. Refer to page 523 for keying instructions.	

Please note: Shelf adjustability is limited to approximately 2.5" up or down per shelf from predetermined shelf height.

# Cabinets, 26 1/2" planning

## Freestanding Multifunction Cabinets

### 49", 64" and 72" high wood interiors

Reff Profiles

description	type	w	d	h	pattern no.	wood	wood	wood	wood
						interiors L	interiors V1	interiors V2	interiors V3
Freestanding multifunctional cabinet, 49"h	Box/Box/File	24"	24"	49"	<b>RC423N</b> ( ) ( ) ( )	\$3,513.	\$4,578.	\$5,202.	\$6,242.
	File/File	24"	24"	49"	<b>RC423M</b> ( ) ( ) ( )	3,132.	4,190.	4,789.	5,747.

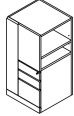

description	type	w	d	h	pattern no.	wood	wood	wood	wood
						interiors L	interiors V1	interiors V2	interiors V3
Freestanding multifunctional cabinet, 64"h	Box/Box/File	24"	24"	64"	<b>RC623N</b> ( ) ( ) ( )	3,723.	4,906.	5,670.	6,803.
	File/File	24"	24"	64"	<b>RC623M</b> ( ) ( ) ( )	3,344.	4,518.	5,285.	6,342.

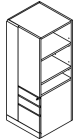

Order Code	Specification Information	Application Notes
Example: <b>RC732BLWNN</b>	<i>To order please specify pattern number including:</i>	
<b>R</b> Reff	1. Hinge location, where applicable	1. <i>Hinge location:</i> L = Left hand R = Right hand
<b>C</b> Cabinets	2. Finish type	2. <i>Finish type:</i> L = Laminate 1 = V1 2 = V2 3 = V3
<b>7</b> 72" high	3. Interior option	3. <i>Interior options:</i> W = Wood (shelves match case finish: L,V1,V2 or V3; drawer interiors cherry veneer)
<b>3</b> 30" wide	4. Pull option	4. <i>Pull options:</i> D = Metal D-pull J = Routed pull C = Nickel C-pull (nickel finish only) S = S-pull (stainless steel finish only)
<b>2</b> 20" deep	5. Lock option, where applicable	5. <i>Lock options:</i> L = Lock hole drilled N = No lock drilling
<b>B</b> Full bookcase	6. Finish, cabinet	10. Refer to page 523 for keying instructions.
<b>L</b> Laminate finish	7. Finish, pull when applicable	
<b>W</b> Wood interior	8. Left hand side of cabinet drilling: N = No drilling Size to drill for each workwall: S0 = 19"H x 15"D S1 = 19"H x 20"D T0 = 23"H x 15"D T1 = 23"H x 20"D	Key alike are field installed using the KnollKey order form. Random locks are factory installed.
<b>N</b> No drilling	9. Right hand side of cabinet drilling: same as #8 above.	<b>Cabinets do not come with lock included. Keying instructions must accompany all cabinet orders.</b>
<b>N</b> No drilling	10. Keying instructions	Hinge door cabinets have optional lock drilling which can be specified in the cabinet product code.
	*After specifying product code, provide keying instructions.	Wardrobe cabinets do not come equipped with coat rod and boot tray. Please specify separately. See page 420.
		File drawers include file bars for front to back and side to side filing.
		File drawers do not support bottom loading.
		Applicable finishes are listed on page 5 and 6.

Please note: Shelf adjustability is limited to approximately 2.5" up or down per shelf from predetermined shelf height.

# Cabinets, 26 1/2" planning

## Freestanding Multifunction Cabinets

### 49", 64" and 72" high wood interiors

description	type	w	d	h	pattern no.	wood	wood	wood	wood
						interiors	interiors	interiors	interiors
						L	V1	V2	V3
Freestanding multifunctional cabinet, 72"h	Box/Box/File	24"	24"	72"	<b>RC723N</b> ( ) ( ) ( )	\$3,872.	\$5,115.	\$5,957.	\$7,148.
	File/File	24"	24"	72"	<b>RC723M</b> ( ) ( ) ( )	3,492.	4,727.	5,564.	6,677.

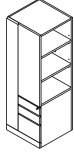

Order Code	Specification Information	Application Notes
Example: <b>RC732BLWNN</b>	<i>To order please specify pattern number including:</i>	
<b>R</b> Reff	1. Hinge location, where applicable	1. <i>Hinge location:</i> L = Left hand R = Right hand
<b>C</b> Cabinets	2. Finish type	2. <i>Finish type:</i> L = Laminate 1 = V1 2 = V2 3 = V3
<b>7</b> 72" high	3. Interior option	3. <i>Interior options:</i> W = Wood (shelves match case finish: L,V1,V2 or V3; drawer interiors cherry veneer)
<b>3</b> 30" wide	4. Pull option	4. <i>Pull options:</i> D = Metal D-pull J = Routed pull C = Nickel C-pull (nickel finish only) S = S-pull (stainless steel finish only)
<b>2</b> 20" deep	5. Lock option, where applicable	5. <i>Lock options:</i> L = Lock hole drilled N = No lock drilling
<b>B</b> Full bookcase	6. Finish, cabinet	10. Refer to page 523 for keying instructions.
<b>L</b> Laminate finish	7. Finish, pull when applicable	
<b>W</b> Wood interior	8. Left hand side of cabinet drilling: N = No drilling Size to drill for each workwall: S0 = 19"H x 15"D S1 = 19"H x 20"D T0 = 23"H x 15"D T1 = 23"H x 20"D	Key alike are field installed using the KnollKey order form. Random locks are factory installed.
<b>N</b> No drilling	9. Right hand side of cabinet drilling: same as #8 above.	<b>Cabinets do not come with lock included. Keying instructions must accompany all cabinet orders.</b>
<b>N</b> No drilling	10. Keying instructions	Hinge door cabinets have optional lock drilling which can be specified in the cabinet product code.
	*After specifying product code, provide keying instructions.	Wardrobe cabinets do not come equipped with coat rod and boot tray. Please specify separately. See page 420.
		File drawers include file bars for front to back and side to side filing.
		File drawers do not support bottom loading.
		Applicable finishes are listed on page 5 and 6.

Please note: Shelf adjustability is limited to approximately 2.5" up or down per shelf from predetermined shelf height.

# Cabinets, 28<sup>3</sup>/<sub>8</sub>" planning 53" high, metal interiors

description	w	d	h	pattern no.	L	V1	V2	V3
Open bookcase w/2 adjustable shelves (for desk height planning)	30"	15"	53"	<b>RC531DHB</b> ( ) ( ) ( )	\$1,220.	\$1,598.	\$1,840.	\$2,484.
	30"	20"	53"	<b>RC532DHB</b> ( ) ( ) ( )	1,376.	1,806.	2,076.	2,803.
	30"	24"	53"	<b>RC533DHB</b> ( ) ( ) ( )	1,553.	2,033.	2,338.	3,157.
	36"	15"	53"	<b>RC561DHB</b> ( ) ( ) ( )	1,355.	1,775.	2,043.	2,758.
	36"	20"	53"	<b>RC562DHB</b> ( ) ( ) ( )	1,528.	2,003.	2,305.	3,111.
	36"	24"	53"	<b>RC563DHB</b> ( ) ( ) ( )	1,719.	2,257.	2,595.	3,502.

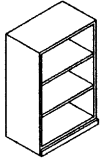

Interior shelves painted metal

description	w	d	h	pattern no.	L	V1	V2	V3
4 drawer lateral file (for desk height planning)	30"	20"	53"	<b>RC532DHF</b> ( ) ( ) ( ) L ( )	2,098.	2,750.	3,161.	4,268.
	30"	24"	53"	<b>RC533DHF</b> ( ) ( ) ( ) L ( )	2,314.	3,031.	3,487.	4,709.
	36"	20"	53"	<b>RC562DHF</b> ( ) ( ) ( ) L ( )	2,659.	3,483.	4,008.	5,410.
	36"	24"	53"	<b>RC563DHF</b> ( ) ( ) ( ) L ( )	2,935.	3,849.	4,426.	5,977.

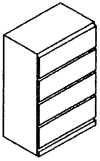

Drawer interiors painted metal

Order Code	Specification Information	Application Notes
Example: <b>RC531DHB(2)(M)(V316)</b>	<i>To order please specify pattern number including:</i>	
<b>R</b> Reff	1. <i>Finish type</i> L = laminate 1 = V1 2 = V2 3 = V3	Cabinets on this page are engineered to align with front sets of 28 <sup>3</sup> / <sub>8</sub> "h pedestals and are intended for "desk height" planning applications. <b>Do not mix products from 26<sup>1</sup>/<sub>2</sub>"h (standard height) planning model with 28<sup>3</sup>/<sub>8</sub>"h (desk height) planning model in any one configuration.</b>  <b>53" nominal height - actual height 52.625"</b>  Shelf adjustability is 2.5" up or down per shelf from equal drilled spacing.  File drawers include file bars for front to back and side to side filing.  File drawers support bottom loading.
<b>C</b> Cabinet	2. <i>Interior Option</i> M = metal (metal shelves or metal drawers) (If laminate case finish- shelves painted to match; if V1,V2 or V3 case finish-shelves painted black; drawer interiors painted black metal)	
<b>5</b> 53" h (nominal)	3. <i>Pull Option (where applicable)</i> D = metal D-pull (finish optional) J = routed J-pull (finish matches case) C = nickel finish C-pull (nickel finish only) S = S-pull (stainless steel finish only)	
<b>3</b> 30" w (nominal)	4. <i>Lock option (where applicable)</i> Drawers always lock drilled L = drilled to accept lock	
<b>1</b> 15" d (nominal)	5. <i>Cabinet finish</i>	
<b>DH</b> Desk height	6. <i>Optional pull finish (where applicable)</i>  Cabinets do not come with lock included. Keying instructions must accompany all cabinet orders, refer to page 523. Random locks are factory installed. Key-alike are field installed using the KnollKey order form.  Applicable finishes are listed on page 5 and 6.	
<b>B</b> Open bookcase		
<b>2</b> Finish type, V2		
<b>M</b> Interior option, metal		
<b>V316</b> Finish, light maple		

# Cabinets, 28<sup>3</sup>/<sub>8</sub>" planning 53" high, wood interiors

Reff Profiles

description	w	d	h	pattern no.	L	V1	V2	V3
Open bookcase w/2 adjustable shelves (for desk height planning)	30"	15"	53"	RC531DHB ( ) ( ) ( )	\$1,368.	\$1,794.	\$2,058.	\$2,777.
	30"	20"	53"	RC532DHB ( ) ( ) ( )	1,522.	1,998.	2,298.	3,101.
	30"	24"	53"	RC533DHB ( ) ( ) ( )	1,698.	2,228.	2,560.	3,456.
	36"	15"	53"	RC561DHB ( ) ( ) ( )	1,503.	1,968.	2,265.	3,057.
	36"	20"	53"	RC562DHB ( ) ( ) ( )	1,676.	2,198.	2,527.	3,410.
	36"	24"	53"	RC563DHB ( ) ( ) ( )	1,867.	2,449.	2,817.	3,801.
4 drawer lateral file (for desk height planning)	30"	20"	53"	RC532DHF ( ) ( ) ( ) L ( )	2,242.	2,941.	3,381.	4,565.
	30"	24"	53"	RC533DHF ( ) ( ) ( ) L ( )	2,463.	3,231.	3,710.	5,008.
	36"	20"	53"	RC562DHF ( ) ( ) ( ) L ( )	2,804.	3,675.	4,226.	5,705.
	36"	24"	53"	RC563DHF ( ) ( ) ( ) L ( )	3,082.	4,038.	4,645.	6,271.

Order Code	Specification Information	Application Notes
Example: <b>RC531DHB(2)(W)(V316)</b>	<i>To order please specify pattern number including:</i>	Cabinets on this page are engineered to align with front sets of 28 <sup>3</sup> / <sub>8</sub> "h pedestals and are intended for "desk height" planning applications. <b>Do not mix products from 26 1/2"h (standard height) planning model with 28 3/8"h (desk height) planning model in any one configuration.</b>
<b>R</b> Reff	4. <i>Lock option (where applicable)</i> Drawers always lock drilled L = drilled to accept lock	
<b>C</b> Cabinet	1. <i>Finish type</i> L = laminate 1 = V1 2 = V2 3 = V3	<b>53" nominal height - actual height 52.625"</b>
<b>5</b> 53" h (nominal)	2. <i>Interior Option</i> W = wood (shelves match case finish and drawer interiors cherry veneer)	
<b>3</b> 30" w (nominal)	3. <i>Pull Option (where applicable)</i> D = metal D-pull (finish optional) J = routed J-pull (finish matches case) C = nickel finish C-pull (nickel finish only) S = S-pull (stainless steel finish only)	Shelf adjustability is 2.5" up or down per shelf from equal drilled spacing.
<b>1</b> 15" d (nominal)		File drawers include file bars for front to back and side to side filing.
<b>DH</b> Desk height		File drawers support bottom loading.
<b>B</b> Open bookcase		
<b>2</b> Finish type, V2		
<b>W</b> Interior option, wood		
<b>V316</b> Finish, light maple		



# Cabinets, 28<sup>3</sup>/<sub>8</sub>" planning 72" high, metal interiors

Reff Profiles

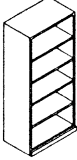
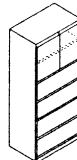
description	w	d	h	pattern no.	metal	metal	metal	metal
					interiors L	interiors V1	interiors V2	interiors V3
 Open bookcase (for desk height planning)	30"	20"	72"	RC7232DHB ( ) ( )	\$1,790.	\$2,348.	\$2,701.	\$3,647.
	30"	24"	72"	RC7233DHB ( ) ( )	1,985.	2,600.	2,992.	4,040.
	36"	20"	72"	RC7262DHB ( ) ( )	2,026.	2,655.	3,054.	4,123.
	36"	24"	72"	RC7263DHB ( ) ( )	2,221.	2,909.	3,346.	4,519.
 Storage w/4 file drwrs& hinged doors above (for desk height planning)	30"	20"	72"	RC7232DHFH ( ) ( ) ( ) ( )	2,941.	3,854.	4,434.	5,984.
	30"	24"	72"	RC7233DHFH ( ) ( ) ( ) ( )	3,268.	4,218.	4,924.	6,647.
	36"	20"	72"	RC7262DHFH ( ) ( ) ( ) ( )	3,249.	4,257.	4,894.	6,608.
	36"	24"	72"	RC7263DHFH ( ) ( ) ( ) ( )	3,606.	4,728.	5,463.	7,338.

Order Code	Specification Information
Example: <b>RC732DHB(2)(M)(V316)</b>	
<b>R</b> Reff	
<b>C</b> Cabinet	
<b>72</b> 72" h (nominal)	
<b>3</b> 30" w (nominal)	
<b>2</b> 20" d (nominal)	
<b>DH</b> Desk height	
<b>B</b> Open bookcase	
<b>2</b> Finish type, V2	
<b>M</b> Interior option, metal	
<b>V316</b> Finish, light maple	

### Specification Information

- To order please specify pattern number including:
- Hinge location (where applicable)**  
L = left hand  
R = right hand
  - Finish type**  
L = laminate  
1 = V1  
2 = V2  
3 = V3
  - Interior Option**  
M = metal (metal shelves or metal drawers)  
(If laminate case finish- shelves painted to match; if V1, V2 or V3 case finish-shelves painted black; drawer interiors painted black metal)
  - Pull Option (where applicable)**  
D = metal D-pull (finish optional)  
J = routed J-pull (finish matches case)  
C = nickel finish C-pull (nickel finish only)  
S = S-pull (stainless steel finish only)  
R = Cylinder  
T = Tab  
F = Bar  
H = Out Line
  - Lock option (where applicable)**  
Optional hinged door configurations only  
Drawers always lock drilled  
L = drilled to accept lock  
N = no drilling

- Cabinet finish**
- Optional pull finish where applicable**

Cabinets do not come with lock included. Keying instructions must accompany all cabinet orders, refer to page 523.  
Random locks are factory installed. Key-alike are field installed using the KnollKey order form.

Product on this page excluding J-pull option will accept woodgrain laminate where laminate is currently an option.  
List price for woodgrain laminate options will be current published laminate list price plus 10%.

### Application Notes

Cabinets on this page are engineered to align with front sets of 28<sup>3</sup>/<sub>8</sub>"h pedestals and are intended for "desk height" planning applications. **Do not mix products from 26 1/2" h (standard height) planning model with 28 3/8" h (desk height) planning model in any one configuration.**

Shelf adjustability is 2.5" up or down per shelf from equal drilled spacing.

File drawers include file bars for front to back and side to side filing.

File drawers support bottom loading.

Coat rods and boots trays for wardrobe cabinets not included. Order separately, see page 420.

Applicable finishes are listed on page 5 and 6.

# Cabinets, 28<sup>3</sup>/<sub>8</sub>" planning 72" high, metal interiors

description	w	d	h	pattern no.	metal	metal	metal	metal
					interiors L	interiors V1	interiors V2	interiors V3
Storage w/upper hinged doors&2 adj shelves, bottom 2 file drawers (for desk height planning)	16"	20"	72"	RC7212DHGH(L/R) ( ) ( ) ( )	\$2,137.	\$2,798.	\$3,221.	\$4,347.
	16"	24"	72"	RC7213DHGH(L/R) ( ) ( ) ( )	2,342.	3,106.	3,572.	4,821.
	30"	20"	72"	RC7232DHGH ( ) ( ) ( )	2,712.	3,557.	4,088.	5,520.
	30"	24"	72"	RC7233DHGH ( ) ( ) ( )	2,983.	3,909.	4,493.	6,067.
	36"	20"	72"	RC7262DHGH ( ) ( ) ( )	2,946.	3,860.	4,441.	5,995.
	36"	24"	72"	RC7263DHGH ( ) ( ) ( )	3,217.	4,217.	4,849.	6,546.

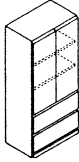

Order Code	Specification Information	Application Notes
Example: <b>RC732DHB(2)(M)(V316)</b>	<i>To order please specify pattern number including:</i>	
<b>R</b> Reff	1. <i>Hinge location (where applicable)</i> L = left hand R = right hand	Cabinets on this page are engineered to align with front sets of 28 <sup>3</sup> / <sub>8</sub> " pedestals and are intended for "desk height" planning applications. <b>Do not mix products from 26 1/2" h (standard height) planning model with 28 3/8" h (desk height) planning model in any one configuration.</b>
<b>C</b> Cabinet	2. <i>Finish type</i> L = laminate 1 = V1 2 = V2 3 = V3	
<b>72</b> 72" h (nominal)	3. <i>Interior Option</i> M = metal (metal shelves or metal drawers) (If laminate case finish- shelves painted to match; if V1, V2 or V3 case finish-shelves painted black; drawer interiors painted black metal)	Shelf adjustability is 2.5" up or down per shelf from equal drilled spacing.
<b>3</b> 30" w (nominal)	4. <i>Pull Option (where applicable)</i> D = metal D-pull (finish optional) J = routed J-pull (finish matches case) C = nickel finish C-pull (nickel finish only) S = S-pull (stainless steel finish only) R = Cylinder T = Tab F = Bar H = Out Line	File drawers include file bars for front to back and side to side filing.
<b>2</b> 20" d (nominal)	5. <i>Lock option (where applicable)</i> Optional hinged door configurations only Drawers always lock drilled L = drilled to accept lock N = no drilling	File drawers support bottom loading.
<b>DH</b> Desk height		Coat rods and boots trays for wardrobe cabinets not included. Order separately, see page 420.
<b>B</b> Open bookcase		
<b>2</b> Finish type, V2		
<b>M</b> Interior option, metal		
<b>V316</b> Finish, light maple		

Applicable finishes are listed on page 5 and 6.

# Cabinets, 28<sup>3</sup>/<sub>8</sub>" planning 72" high, metal interiors

description	w	d	h	pattern no.	metal	metal	metal	metal
					interiors L	interiors V1	interiors V2	interiors V3
Wardrobe/bookcase combo w/full height doors (for desk height planning)	30"	20"	72"	RC7232DHEH(L/R) ( ) ( ) ( )	\$2,896.	\$3,794.	\$4,367.	\$5,894.
	30"	24"	72"	RC7233DHEH(L/R) ( ) ( ) ( )	3,239.	4,244.	4,883.	6,591.
	36"	20"	72"	RC7262DHEH(L/R) ( ) ( ) ( )	3,175.	4,160.	4,784.	6,457.
	36"	24"	72"	RC7263DHEH(L/R) ( ) ( ) ( )	3,543.	4,650.	5,343.	7,214.

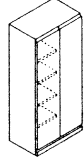

Left hand shown

Requires one lock core per cabinet  
Shelves painted metal

Order Code	Specification Information
Example: <b>RC732DHB(2)(M)(V316)</b>	
<b>R</b> Reff	
<b>C</b> Cabinet	
<b>72</b> 72" h (nominal)	
<b>3</b> 30" w (nominal)	
<b>2</b> 20" d (nominal)	
<b>DH</b> Desk height	
<b>B</b> Open bookcase	
<b>2</b> Finish type, V2	
<b>M</b> Interior option, metal	
<b>V316</b> Finish, light maple	

### Specification Information

- To order please specify pattern number including:
- Hinge location (where applicable)**  
L = left hand  
R = right hand
  - Finish type**  
L = laminate  
1 = V1  
2 = V2  
3 = V3
  - Interior Option**  
M = metal (metal shelves or metal drawers)  
(If laminate case finish- shelves painted to match; if V1, V2 or V3 case finish-shelves painted black; drawer interiors painted black metal)
  - Pull Option (where applicable)**  
D = metal D-pull (finish optional)  
J = routed J-pull (finish matches case)  
C = nickel finish C-pull (nickel finish only)  
S = S-pull (stainless steel finish only)  
R = Cylinder  
T = Tab  
F = Bar  
H = Out Line
  - Lock option (where applicable)**  
Optional hinged door configurations only  
Drawers always lock drilled  
L = drilled to accept lock  
N = no drilling

### Application Notes

- Cabinet finish**
  - Optional pull finish where applicable**  
Cabinets do not come with lock included. Keying instructions must accompany all cabinet orders, refer to page 523.  
Random locks are factory installed. Key-alike are field installed using the KnollKey order form.
  - Product on this page excluding J-pull option will accept woodgrain laminate where laminate is currently an option.  
List price for woodgrain laminate options will be current published laminate list price plus 10%.
- Cabinets on this page are engineered to align with front sets of 28<sup>3</sup>/<sub>8</sub>"h pedestals and are intended for "desk height" planning applications. **Do not mix products from 26 1/2" h (standard height) planning model with 28 3/8" h (desk height) planning model in any one configuration.**
- Shelf adjustability is 2.5" up or down per shelf from equal drilled spacing.
- File drawers include file bars for front to back and side to side filing.
- File drawers support bottom loading.
- Coat rods and boots trays for wardrobe cabinets not included. Order separately, see page 420.

Applicable finishes are listed on page 5 and 6.

# Cabinets, 28<sup>3</sup>/<sub>8</sub>" planning 72" high, wood interiors

Reff Profiles

description	w	d	h	pattern no.	wood	wood	wood	wood
					interiors	interiors	interiors	interiors
					L	V1	V2	V3
Open bookcase (for desk height planning) 	30"	20"	72"	<b>RC7232DHB</b> ( ) ( )	\$1,924.	\$2,523.	\$2,901.	\$3,916.
	30"	24"	72"	<b>RC7233DHB</b> ( ) ( )	2,118.	2,778.	3,193.	4,311.
	36"	20"	72"	<b>RC7262DHB</b> ( ) ( )	2,161.	2,832.	3,256.	4,395.
	36"	24"	72"	<b>RC7263DHB</b> ( ) ( )	2,354.	3,086.	3,548.	4,791.

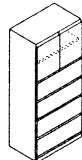
Storage w/4 file drwrs& hinged doors above (for desk height planning) 	30"	20"	72"	<b>RC7232DHFH</b> ( ) ( ) ( ) ( )	3,075.	4,029.	4,633.	6,254.
	30"	24"	72"	<b>RC7233DHFH</b> ( ) ( ) ( ) ( )	3,402.	4,458.	5,125.	6,918.
	36"	20"	72"	<b>RC7262DHFH</b> ( ) ( ) ( ) ( )	3,383.	4,436.	5,112.	6,901.
	36"	24"	72"	<b>RC7263DHFH</b> ( ) ( ) ( ) ( )	3,739.	4,902.	5,640.	7,615.

Storage w/upper hinged doors&2 adj shelves, bottom 2 file drawers (for desk height planning) 	16"	20"	72"	<b>RC7212DHGH(L/R)</b> ( ) ( ) ( )	2,272.	2,977.	3,423.	4,620.
	16"	24"	72"	<b>RC7213DHGH(L/R)</b> ( ) ( ) ( )	2,504.	3,281.	3,773.	5,093.
	30"	20"	72"	<b>RC7232DHGH</b> ( ) ( ) ( )	2,848.	3,729.	4,290.	5,792.
	30"	24"	72"	<b>RC7233DHGH</b> ( ) ( ) ( )	3,116.	4,085.	4,696.	6,341.
	36"	20"	72"	<b>RC7262DHGH</b> ( ) ( ) ( )	3,081.	4,037.	4,643.	6,268.
	36"	24"	72"	<b>RC7263DHGH</b> ( ) ( ) ( )	3,353.	4,394.	5,053.	6,821.

Order Code	Specification Information	Application Notes
Example: <b>RC732DHB(2)(W)(V316)</b>	<i>To order please specify pattern number including:</i>	Cabinets on this page are engineered to align with front sets of 28 <sup>3</sup> / <sub>8</sub> "h pedestals and are intended for "desk height" planning applications. <b>Do not mix products from 26 1/2"h (standard height) planning model with 28 3/8"h (desk height) planning model in any one configuration.</b>
<b>R</b> Reff	6. <i>Cabinet finish</i>	Shelf adjustability is 2.5" up or down per shelf from equal drilled spacing.
<b>C</b> Cabinet	7. <i>Optional pull finish where applicable</i>	File drawers include file bars for front to back and side to side filing.
<b>72</b> 72" h (nominal)	1. <i>Hinge location (where applicable)</i> L = left hand R = right hand	File drawers support bottom loading.
<b>3</b> 30" w (nominal)	2. <i>Finish type</i> L = laminate 1 = V1 2 = V2 3 = V3	Coat rods and boots trays for wardrobe cabinets not included. Order separately, see page 420.
<b>2</b> 20" d (nominal)	3. <i>Interior Option</i> W = wood (shelves match case finish and drawer interiors cherry veneer)	
<b>DH</b> Desk height	4. <i>Pull Option (where applicable)</i> D = metal D-pull (finish optional) J = routed J-pull (finish matches case) C = nickel finish C-pull (nickel finish only) S = S-pull (stainless steel finish only) R = Cylinder T = Tab F = Bar H = Out Line	
<b>B</b> Open bookcase	5. <i>Lock option (where applicable)</i> Optional hinged door configurations only Drawers always lock drilled L = drilled to accept lock N = no drilling	
<b>2</b> Finish type, V2		
<b>W</b> Interior option, wood		
<b>V316</b> Finish, light maple		

Applicable finishes are listed on page 5 and 6.

# Cabinets, 28<sup>3</sup>/<sub>8</sub>" planning 72" high, wood interiors

description	w	d	h	pattern no.	wood interiors L	wood interiors V1	wood interiors V2	wood interiors V3
Wardrobe/bookcase combo w/full height doors (for desk height planning)	30"	24"	72"	RC7233DHEH(L/R) ( ) ( ) ( )	\$3,372.	\$4,421.	\$5,084.	\$6,863.
	36"	20"	72"	RC7262DHEH(L/R) ( ) ( ) ( )	3,309.	4,336.	4,988.	6,734.
	36"	24"	72"	RC7263DHEH(L/R) ( ) ( ) ( )	3,680.	4,823.	5,548.	7,489.

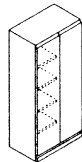

Left hand shown

Requires one lock core per cabinet.  
Shelves painted metal

Wardrobe cabinet (for desk height planning)	16"	20"	72"	RC7212DHDH(L/R) ( ) ( ) ( )	1,699.	2,228.	2,562.	3,459.
	16"	24"	72"	RC7213DHDH(L/R) ( ) ( ) ( )	1,870.	2,451.	2,818.	3,804.
	30"	20"	72"	RC7232DHDH ( ) ( ) ( )	2,140.	2,805.	3,224.	4,352.
	30"	24"	72"	RC7233DHDH ( ) ( ) ( )	2,351.	3,082.	3,544.	4,786.
	36"	20"	72"	RC7262DHDH ( ) ( ) ( )	2,352.	3,084.	3,547.	4,790.
	36"	24"	72"	RC7263DHDH ( ) ( ) ( )	2,586.	3,390.	3,899.	5,263.

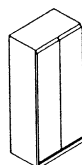

Requires one lock core per cabinet.  
Order coat rod and hood tray from accessories

Order Code	Specification Information	Application Notes
Example: <b>RC732DHB(2)(W)(V316)</b>	<i>To order please specify pattern number including:</i>	<p>6. <i>Cabinet finish</i></p> <p>7. <i>Optional pull finish where applicable</i></p> <p>Cabinets do not come with lock included. Keying instructions must accompany all cabinet orders, refer to page 523. Random locks are factory installed. Key-alike are field installed using the KnollKey order form.</p> <p>Product on this page excluding J-pull option will accept woodgrain laminate where laminate is currently an option. List price for woodgrain laminate options will be current published laminate list price plus 10%.</p> <p>Cabinets on this page are engineered to align with front sets of 28<sup>3</sup>/<sub>8</sub>" h pedestals and are intended for "desk height" planning applications. <b>Do not mix products from 26 1/2" h (standard height) planning model with 28 3/8" h (desk height) planning model in any one configuration.</b></p> <p>Shelf adjustability is 2.5" up or down per shelf from equal drilled spacing.</p> <p>File drawers include file bars for front to back and side to side filing.</p> <p>File drawers support bottom loading.</p> <p>Coat rods and boots trays for wardrobe cabinets not included. Order separately, see page 420.</p>
<b>R</b>	Reff	
<b>C</b>	Cabinet	
<b>72</b>	72" h (nominal)	
<b>3</b>	30" w (nominal)	
<b>2</b>	20" d (nominal)	
<b>DH</b>	Desk height	
<b>B</b>	Open bookcase	
<b>2</b>	Finish type, V2	
<b>W</b>	Interior option, wood	
<b>V316</b>	Finish, light maple	
	1. <i>Hinge location (where applicable)</i> L = left hand R = right hand	
	2. <i>Finish type</i> L = laminate 1 = V1 2 = V2 3 = V3	
	3. <i>Interior Option</i> W = wood (shelves match case finish and drawer interiors cherry veneer)	
	4. <i>Pull Option (where applicable) optional</i> D = metal D-pull (finish matches case) J = routed J-pull (finish matches case) C = nickel finish C-pull (nickel finish only) S = S-pull (stainless steel finish only) R = Cylinder T = Tab F = Bar H = Out Line	
	5. <i>Lock option (where applicable)</i> Optional hinged door configurations only Drawers always lock drilled L = drilled to accept lock N = no drilling	

Applicable finishes are listed on page 5 and 6.

Cabinetry

# Cabinets, 28<sup>3</sup>/<sub>8</sub>" planning 75" high, metal interiors

Reff Profiles

description	w	d	h	pattern no.	metal	metal	metal	metal
					interiors L	interiors V1	interiors V2	interiors V3
Open bookcase (for desk height planning)	30"	20"	75"	RC732DHB ( ) ( ) ( ) ( )	\$1,960.	\$2,567.	\$2,953.	\$3,988.
	30"	24"	75"	RC733DHB ( ) ( ) ( ) ( )	2,172.	2,845.	3,272.	4,418.
	36"	20"	75"	RC762DHB ( ) ( ) ( ) ( )	2,217.	2,905.	3,341.	4,510.
	36"	24"	75"	RC763DHB ( ) ( ) ( ) ( )	2,429.	3,185.	3,662.	4,943.

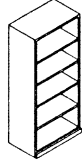

Shelves painted metal

Wardrobe/bookcase combo w/full height doors (for desk height planning)	30"	20"	75"	RC732DHE(L/R) ( ) ( ) ( ) ( ) ( )	3,169.	4,148.	4,777.	6,447.
	30"	24"	75"	RC733DHE(L/R) ( ) ( ) ( ) ( ) ( )	3,542.	4,643.	5,343.	7,213.
	36"	20"	75"	RC762DHE(L/R) ( ) ( ) ( ) ( ) ( )	3,474.	4,554.	5,234.	7,066.
	36"	24"	75"	RC763DHE(L/R) ( ) ( ) ( ) ( ) ( )	3,875.	5,087.	5,845.	7,890.

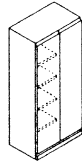

Requires one lock core per cabinet  
Shelves painted metal

Left hand shown

Order Code	Specification Information	Application Notes
Example: <b>RC732DHB(2)(M)(V316)</b>	<i>To order please specify pattern number including:</i>	
<b>R</b> Reff	1. <i>Hinge location (where applicable)</i> L = left hand R = right hand	
<b>C</b> Cabinet	2. <i>Finish type</i> L = laminate 1 = V1 2 = V2 3 = V3	
<b>7</b> 75" h (nominal)	3. <i>Interior Option</i> M = metal (metal shelves or metal drawers) (If laminate case finish- shelves painted to match; if V1, V2 or V3 case finish-shelves painted black; drawer interiors painted black metal)	
<b>3</b> 30" w (nominal)	4. <i>Pull Option (where applicable)</i> D = metal D-pull (finish optional) J = routed J-pull (finish matches case) C = nickel finish C-pull (nickel finish only) S = S-pull (stainless steel finish only) R = Cylinder T = Tab F = Bar H = Out Line	
<b>2</b> 20" d (nominal)	5. <i>Lock option (where applicable)</i> Optional hinged door configurations only Drawers always lock drilled L = drilled to accept lock N = no drilling	
<b>DH</b> Desk height	6. <i>Cabinet finish</i>	
<b>B</b> Open bookcase	7. <i>Optional pull finish where applicable</i>	
<b>2</b> Finish type, V2	8. <i>Optional drilling to support workwall, left side</i> N = no drilling S0 = 19"h x 15"d S1 = 19"h x 20"d T0 = 23"h x 15"d T1 = 23"h x 20"d	
<b>M</b> Interior option, metal	9. <i>Optional drilling to support workwall, right side</i> *drilling options same as #8 above	
<b>V316</b> Finish, light maple		

Applicable finishes are listed on page 5 and 6.

Cabinets do not come with lock included. Keying instructions must accompany all cabinet orders, refer to page 523.

Random locks are factory installed. Key-alike are field installed using the KnollKey order form.

Product on this page excluding J-pull option will accept woodgrain laminate where laminate is currently an option.

List price for woodgrain laminate options will be current published laminate list price plus 10%.

Cabinets on this page are engineered to align with front sets of 28<sup>3</sup>/<sub>8</sub>" pedestals and are intended for "desk height" planning applications. **Do not mix products from 26 1/2" h (standard height) planning model with 28 3/8" h (desk height) planning model in any one configuration.**

**75" nominal height - actual height 75.125"**

Shelf adjustability is 2.5" up or down per shelf from equal drilled spacing.

File drawers include file bars for front to back and side to side filing.

File drawers support bottom loading.

Coat rods and boots trays for wardrobe cabinets not included. Order separately, see page 420.

These 75" cabinets are intended to be used with the overdesk units only.

# Cabinets, 28<sup>3</sup>/<sub>8</sub>" planning 75" high, metal interiors

description	w	d	h	pattern no.	metal	metal	metal	metal
					interiors L	interiors V1	interiors V2	interiors V3
Storage w/upper hinged doors & 2 adj shelves, bottom 2 file drawers (for desk height planning)	16"	20"	75"	RC712DHG(L/R) ( ) ( ) (L) ( ) ( ) ( )	\$2,338.	\$3,063.	\$3,524.	\$4,758.
	16"	24"	75"	RC713DHG(L/R) ( ) ( ) (L) ( ) ( ) ( )	2,562.	3,396.	3,906.	5,275.
	30"	20"	75"	RC732DHG ( ) ( ) (L) ( ) ( ) ( )	2,969.	3,891.	4,472.	6,038.
	30"	24"	75"	RC733DHG ( ) ( ) (L) ( ) ( ) ( )	3,265.	4,276.	4,919.	6,640.
	36"	20"	75"	RC762DHG ( ) ( ) (L) ( ) ( ) ( )	3,222.	4,223.	4,859.	6,560.
	36"	24"	75"	RC763DHG ( ) ( ) (L) ( ) ( ) ( )	3,520.	4,613.	5,306.	7,164.

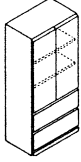

Requires two lock cores per cabinet  
Shelves painted metal, drawer interiors painted black metal

Order Code	Specification Information	Application Notes
Example: <b>RC732DHB(2)(M)(V316)</b>	<i>To order please specify pattern number including:</i>	
<b>R</b> Reff	1. <i>Hinge location (where applicable)</i> L = left hand R = right hand	<p>Cabinets on this page are engineered to align with front sets of 28<sup>3</sup>/<sub>8</sub>"h pedestals and are intended for "desk height" planning applications. <b>Do not mix products from 26 1/2"h (standard height) planning model with 28 3/8"h (desk height) planning model in any one configuration.</b></p> <p><b>75" nominal height - actual height 75.125"</b></p> <p>Shelf adjustability is 2.5" up or down per shelf from equal drilled spacing.</p> <p>File drawers include file bars for front to back and side to side filing.</p> <p>File drawers support bottom loading.</p> <p>Coat rods and boots trays for wardrobe cabinets not included. Order separately, see page 420.</p> <p>These 75" cabinets are intended to be used with the overdesk units only.</p>
<b>C</b> Cabinet	2. <i>Finish type</i> L = laminate 1 = V1 2 = V2 3 = V3	
<b>7</b> 75" h (nominal)	3. <i>Interior Option</i> M = metal (metal shelves or metal drawers) (If laminate case finish- shelves painted to match; if V1, V2 or V3 case finish-shelves painted black; drawer interiors painted black metal)	
<b>3</b> 30" w (nominal)	4. <i>Pull Option (where applicable)</i> D = metal D-pull (finish optional) J = routed J-pull (finish matches case) C = nickel finish C-pull (nickel finish only) S = S-pull (stainless steel finish only) R = Cylinder T = Tab F = Bar H = Out Line	
<b>2</b> 20" d (nominal)	5. <i>Lock option (where applicable)</i> Optional hinged door configurations only Drawers always lock drilled L = drilled to accept lock N = no drilling	
<b>DH</b> Desk height	6. <i>Cabinet finish</i>	
<b>B</b> Open bookcase	7. <i>Optional pull finish where applicable</i>	
<b>2</b> Finish type, V2	8. <i>Optional drilling to support workwall, left side</i> N = no drilling S0 = 19"h x 15"d S1 = 19"h x 20"d T0 = 23"h x 15"d T1 = 23"h x 20"d	
<b>M</b> Interior option, metal	9. <i>Optional drilling to support workwall, right side</i> *drilling options same as #8 above	
<b>V316</b> Finish, light maple	Cabinets do not come with lock included. Keying instructions must accompany all cabinet orders, refer to page 523. Random locks are factory installed. Key-alike are field installed using the KnollKey order form.  Product on this page excluding J-pull option will accept woodgrain laminate where laminate is currently an option. List price for woodgrain laminate options will be current published laminate list price plus 10%.	

Applicable finishes are listed on page 5 and 6.

# Cabinets, 28<sup>3</sup>/<sub>8</sub>" planning 75" high, metal interiors

description	w	d	h	pattern no.	metal	metal	metal	metal
					interiors L	interiors V1	interiors V2	interiors V3
Storage open above w/2 adj shelves, bottom 2 file drawers (for desk height planning)	30"	20"	75"	<b>RC732DHK</b> ( ) ( ) (L) ( ) ( )	\$2,875.	\$3,773.	\$4,355.	\$5,878.
	30"	24"	75"	<b>RC733DHK</b> ( ) ( ) (L) ( ) ( )	3,171.	4,157.	4,799.	6,479.
	36"	20"	75"	<b>RC762DHK</b> ( ) ( ) (L) ( ) ( )	3,128.	4,104.	4,741.	6,400.
	36"	24"	75"	<b>RC763DHK</b> ( ) ( ) (L) ( ) ( )	3,426.	4,495.	5,188.	7,003.

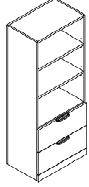

Requires one lock core per cabinet  
Shelves painted metal, drawer interiors painted black metal

Order Code	Specification Information	Application Notes
Example: <b>RC732DHB(2)(M)(V316)</b>	<i>To order please specify pattern number including:</i>	
<b>R</b> Reff	1. <i>Hinge location (where applicable)</i> L = left hand R = right hand	<p>Cabinets on this page are engineered to align with front sets of 28<sup>3</sup>/<sub>8</sub>"h pedestals and are intended for "desk height" planning applications. <b>Do not mix products from 26 1/2" h (standard height) planning model with 28 3/8" h (desk height) planning model in any one configuration.</b></p> <p><b>75" nominal height - actual height 75.125"</b></p> <p>Shelf adjustability is 2.5" up or down per shelf from equal drilled spacing.</p> <p>File drawers include file bars for front to back and side to side filing.</p> <p>File drawers support bottom loading.</p> <p>Coat rods and boots trays for wardrobe cabinets not included. Order separately, see page 420.</p> <p>These 75" cabinets are intended to be used with the overdesk units only.</p>
<b>C</b> Cabinet	2. <i>Finish type</i> L = laminate 1 = V1 2 = V2 3 = V3	
<b>7</b> 75" h (nominal)	3. <i>Interior Option</i> M = metal (metal shelves or metal drawers) (If laminate case finish- shelves painted to match; if V1, V2 or V3 case finish-shelves painted black; drawer interiors painted black metal)	
<b>3</b> 30" w (nominal)	4. <i>Pull Option (where applicable)</i> D = metal D-pull (finish optional) J = routed J-pull (finish matches case) C = nickel finish C-pull (nickel finish only) S = S-pull (stainless steel finish only) R = Cylinder T = Tab F = Bar H = Out Line	
<b>2</b> 20" d (nominal)	5. <i>Lock option (where applicable)</i> Optional hinged door configurations only Drawers always lock drilled L = drilled to accept lock N = no drilling	
<b>DH</b> Desk height	6. <i>Cabinet finish</i>	
<b>B</b> Open bookcase	7. <i>Optional pull finish where applicable</i>	
<b>2</b> Finish type, V2	8. <i>Optional drilling to support workwall, left side</i> N = no drilling S0 = 19"h x 15"d S1 = 19"h x 20"d T0 = 23"h x 15"d T1 = 23"h x 20"d	
<b>M</b> Interior option, metal	9. <i>Optional drilling to support workwall, right side</i> *drilling options same as #8 above	
<b>V316</b> Finish, light maple	Cabinets do not come with lock included. Keying instructions must accompany all cabinet orders, refer to page 523. Random locks are factory installed. Key-alike are field installed using the KnollKey order form.  Product on this page excluding J-pull option will accept woodgrain laminate where laminate is currently an option. List price for woodgrain laminate options will be current published laminate list price plus 10%.	

Applicable finishes are listed on page 5 and 6.



# Cabinets, 28<sup>3</sup>/<sub>8</sub>" planning 75" high, metal interiors

description	w	d	h	pattern no.	metal interiors L	metal interiors V1	metal interiors V2	metal interiors V3
Storage w/4 file drwrs& hinged doors above (for desk height planning)	30"	20"	75"	RC732DHF ( ) ( ) L ( ) ( ) ( )	\$3,218.	\$4,216.	\$4,851.	\$6,548.
	30"	24"	75"	RC733DHF ( ) ( ) L ( ) ( ) ( )	3,574.	4,683.	5,387.	7,273.
	36"	20"	75"	RC762DHF ( ) ( ) L ( ) ( ) ( )	3,554.	4,659.	5,357.	7,233.
	36"	24"	75"	RC763DHF ( ) ( ) L ( ) ( ) ( )	3,947.	5,171.	5,948.	8,030.

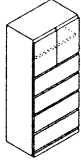

Requires two lock cores per cabinet  
Drawer interiors painted black metal

Order Code	Specification Information	Application Notes
Example: <b>RC732DHB(2)(M)(V316)</b>	<i>To order please specify pattern number including:</i>	
<b>R</b> Reff	1. <i>Hinge location (where applicable)</i> L = left hand R = right hand	Cabinets on this page are engineered to align with front sets of 28 <sup>3</sup> / <sub>8</sub> "h pedestals and are intended for "desk height" planning applications. <b>Do not mix products from 26 1/2" h (standard height) planning model with 28 3/8" h (desk height) planning model in any one configuration.</b>  <b>75" nominal height - actual height 75.125"</b>  Shelf adjustability is 2.5" up or down per shelf from equal drilled spacing.  File drawers include file bars for front to back and side to side filing.  File drawers support bottom loading.  Coat rods and boots trays for wardrobe cabinets not included. Order separately, see page 420.  These 75" cabinets are intended to be used with the overdesk units only.
<b>C</b> Cabinet	2. <i>Finish type</i> L = laminate 1 = V1 2 = V2 3 = V3	
<b>7</b> 75" h (nominal)	3. <i>Interior Option</i> M = metal (metal shelves or metal drawers) (If laminate case finish- shelves painted to match; if V1, V2 or V3 case finish-shelves painted black; drawer interiors painted black metal)	
<b>3</b> 30" w (nominal)	4. <i>Pull Option (where applicable)</i> D = metal D-pull (finish optional) J = routed J-pull (finish matches case) C = nickel finish C-pull (nickel finish only) S = S-pull (stainless steel finish only) R = Cylinder T = Tab F = Bar H = Out Line	
<b>2</b> 20" d (nominal)	5. <i>Lock option (where applicable)</i> Optional hinged door configurations only Drawers always lock drilled L = drilled to accept lock N = no drilling	
<b>DH</b> Desk height	6. <i>Cabinet finish</i>	
<b>B</b> Open bookcase	7. <i>Optional pull finish where applicable</i>	
<b>2</b> Finish type, V2	8. <i>Optional drilling to support workwall, left side</i> N = no drilling S0 = 19"h x 15"d S1 = 19"h x 20"d T0 = 23"h x 15"d T1 = 23"h x 20"d	
<b>M</b> Interior option, metal	9. <i>Optional drilling to support workwall, right side</i> *drilling options same as #8 above	
<b>V316</b> Finish, light maple	Cabinets do not come with lock included. Keying instructions must accompany all cabinet orders, refer to page 523. Random locks are factory installed. Key-alike are field installed using the KnollKey order form.  Product on this page excluding J-pull option will accept woodgrain laminate where laminate is currently an option. List price for woodgrain laminate options will be current published laminate list price plus 10%.	

Applicable finishes are listed on page 5 and 6.

# Cabinets, 28<sup>3</sup>/<sub>8</sub>" planning 75" high, wood interiors

Reff Profiles

description	w	d	h	pattern no.	wood	wood	wood	wood
					interiors L	interiors V1	interiors V2	interiors V3
Open bookcase (for desk height planning)	30"	20"	75"	RC732DHB ( ) ( ) ( ) ( )	\$2,106.	\$2,758.	\$3,173.	\$4,284.
	30"	24"	75"	RC733DHB ( ) ( ) ( ) ( )	2,318.	3,038.	3,494.	4,715.
	36"	20"	75"	RC762DHB ( ) ( ) ( ) ( )	2,365.	3,099.	3,564.	4,810.
	36"	24"	75"	RC763DHB ( ) ( ) ( ) ( )	2,576.	3,378.	3,884.	5,243.
Wardrobe/bookcase combo w/full height doors (for desk height planning)	30"	20"	75"	RC732DHE(L/R) ( ) ( ) ( ) ( ) ( )	3,315.	4,343.	4,995.	6,744.
	30"	24"	75"	RC733DHE(L/R) ( ) ( ) ( ) ( ) ( )	3,690.	4,838.	5,563.	7,511.
	36"	20"	75"	RC762DHE(L/R) ( ) ( ) ( ) ( ) ( )	3,621.	4,744.	5,457.	7,367.
	36"	24"	75"	RC763DHE(L/R) ( ) ( ) ( ) ( ) ( )	4,026.	5,280.	6,070.	8,194.

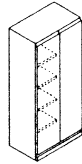
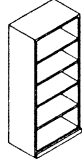

Requires one lock core per cabinet

Left hand shown

Order Code	Specification Information	Application Notes
Example: <b>RC732DHB(2)(W)(V316)</b>	<i>To order please specify pattern number including:</i>	Cabinets on this page are engineered to align with front sets of 28 <sup>3</sup> / <sub>8</sub> "h pedestals and are intended for "desk height" planning applications. <b>Do not mix products from 26 1/2"h (standard height) planning model with 28 3/8"h (desk height) planning model in any one configuration.</b>
<b>R</b> Reff	1. <i>Hinge location (where applicable)</i> L = left hand R = right hand	<b>75" nominal height - actual height 75.125"</b>
<b>C</b> Cabinet	2. <i>Finish type</i> L = laminate 1 = V1 2 = V2 3 = V3	Shelf adjustability is 2.5" up or down per shelf from equal drilled spacing.
<b>7</b> 75" h (nominal)	3. <i>Interior Option</i> W = wood (shelves match case finish and drawer interiors cherry veneer)	File drawers include file bars for front to back and side to side filing.
<b>3</b> 30" w (nominal)	4. <i>Pull Option (where applicable)</i> D = metal D-pull (finish optional) J = routed J-pull (finish matches case) C = nickel finish C-pull (nickel finish only) S = S-pull (stainless steel finish only) R = Cylinder T = Tab F = Bar H = Out Line	File drawers support bottom loading.
<b>2</b> 20" d (nominal)	5. <i>Lock option (where applicable)</i> Optional hinged door configurations only Drawers always lock drilled L = drilled to accept lock N = no drilling	Coat rods and boots trays for wardrobe cabinets not included. Order separately, see page 420.
<b>DH</b> Desk height	6. <i>Cabinet finish</i>	These 75" cabinets are intended to be used with the overdesk units only.
<b>B</b> Open bookcase	7. <i>Optional pull finish where applicable</i>	
<b>2</b> Finish type, V2	8. <i>Optional drilling to support workwall, left side</i> N = no drilling S0 = 19"h x 15"d S1 = 19"h x 20"d T0 = 23"h x 15"d T1 = 23"h x 20"d	
<b>W</b> Interior option, wood	9. <i>Optional drilling to support workwall, right side</i> *drilling options same as #8 above	
<b>V316</b> Finish, light maple	Cabinets do not come with lock included. Keying instructions must accompany all cabinet orders, refer to page 523. Random locks are factory installed. Key-alike are field installed using the KnollKey order form.  Product on this page excluding J-pull option will accept woodgrain laminate where laminate is currently an option. List price for woodgrain laminate options will be current published laminate list price plus 10%.	

Applicable finishes are listed on page 5 and 6.

# Cabinets, 28<sup>3</sup>/<sub>8</sub>" planning 75" high, wood interiors

Reff Profiles

description	w	d	h	pattern no.	wood	wood	wood	wood
					interiors L	interiors V1	interiors V2	interiors V3
Storage w/upper hinged doors & 2 adj shelves, bottom 2 file drawers (for desk height planning)	16"	20"	75"	RC712DHG(L/R) ( ) ( ) ( ) ( ) ( )	\$2,485.	\$3,255.	\$3,744.	\$5,055.
	16"	24"	75"	RC713DHG(L/R) ( ) ( ) ( ) ( ) ( )	2,740.	3,589.	4,128.	5,574.
	30"	20"	75"	RC732DHG ( ) ( ) ( ) ( ) ( ) ( )	3,116.	4,079.	4,694.	6,336.
	30"	24"	75"	RC733DHG ( ) ( ) ( ) ( ) ( ) ( )	3,410.	4,469.	5,139.	6,937.
	36"	20"	75"	RC762DHG ( ) ( ) ( ) ( ) ( ) ( )	3,370.	4,417.	5,079.	6,856.
	36"	24"	75"	RC763DHG ( ) ( ) ( ) ( ) ( ) ( )	3,667.	4,807.	5,528.	7,464.

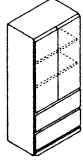

Requires two lock cores per cabinet

Order Code	Specification Information	Application Notes
Example: <b>RC732DHB(2)(W)(V316)</b>	<i>To order please specify pattern number including:</i>	Cabinets on this page are engineered to align with front sets of 28 <sup>3</sup> / <sub>8</sub> "h pedestals and are intended for "desk height" planning applications. <b>Do not mix products from 26 1/2"h (standard height) planning model with 28 3/8"h (desk height) planning model in any one configuration.</b>
<b>R</b> Reff	1. <i>Hinge location (where applicable)</i> L = left hand R = right hand	<b>75" nominal height - actual height 75.125"</b>
<b>C</b> Cabinet	2. <i>Finish type</i> L = laminate 1 = V1 2 = V2 3 = V3	Shelf adjustability is 2.5" up or down per shelf from equal drilled spacing.
<b>7</b> 75" h (nominal)	3. <i>Interior Option</i> W = wood (shelves match case finish and drawer interiors cherry veneer)	File drawers include file bars for front to back and side to side filing.
<b>3</b> 30" w (nominal)	4. <i>Pull Option (where applicable)</i> D = metal D-pull (finish optional) J = routed J-pull (finish matches case) C = nickel finish C-pull (nickel finish only) S = S-pull (stainless steel finish only) R = Cylinder T = Tab F = Bar H = Out Line	File drawers support bottom loading.
<b>2</b> 20" d (nominal)	5. <i>Lock option (where applicable)</i> Optional hinged door configurations only Drawers always lock drilled L = drilled to accept lock N = no drilling	Coat rods and boots trays for wardrobe cabinets not included. Order separately, see page 420.
<b>DH</b> Desk height	6. <i>Cabinet finish</i>	These 75" cabinets are intended to be used with the overdesk units only.
<b>B</b> Open bookcase	7. <i>Optional pull finish where applicable</i>	
<b>2</b> Finish type, V2	8. <i>Optional drilling to support workwall, left side</i> N = no drilling S0 = 19"h x 15"d S1 = 19"h x 20"d T0 = 23"h x 15"d T1 = 23"h x 20"d	
<b>W</b> Interior option, wood	9. <i>Optional drilling to support workwall, right side</i> *drilling options same as #8 above	
<b>V316</b> Finish, light maple	Cabinets do not come with lock included. Keying instructions must accompany all cabinet orders, refer to page 523. Random locks are factory installed. Key-alike are field installed using the KnollKey order form.  Product on this page excluding J-pull option will accept woodgrain laminate where laminate is currently an option. List price for woodgrain laminate options will be current published laminate list price plus 10%.	

Applicable finishes are listed on page 5 and 6.

# Cabinets, 28<sup>3</sup>/<sub>8</sub>" planning 75" high, wood interiors

Reff Profiles

description	w	d	h	pattern no.	wood	wood	wood	wood
					interiors L	interiors V1	interiors V2	interiors V3
Storage open above w/2 adj shelves, bottom 2 file drawers (for desk height planning)	30"	20"	75"	RC732DHK ( ) ( ) L ( ) ( )	\$3,022.	\$3,962.	\$4,574.	\$6,175.
	30"	24"	75"	RC733DHK ( ) ( ) L ( ) ( )	3,317.	4,349.	5,021.	6,778.
	36"	20"	75"	RC762DHK ( ) ( ) L ( ) ( )	3,276.	4,298.	4,962.	6,700.
	36"	24"	75"	RC763DHK ( ) ( ) L ( ) ( )	3,573.	4,688.	5,409.	7,302.

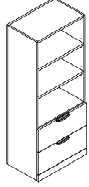

Requires one lock core per cabinet

Order Code	Specification Information	Application Notes
Example: <b>RC732DHB(2)(W)(V316)</b>	<i>To order please specify pattern number including:</i>	
<b>R</b> Reff		
<b>C</b> Cabinet		
<b>7</b> 75" h (nominal)		
<b>3</b> 30" w (nominal)		
<b>2</b> 20" d (nominal)		
<b>DH</b> Desk height		
<b>B</b> Open bookcase		
<b>2</b> Finish type, V2		
<b>W</b> Interior option, wood		
<b>V316</b> Finish, light maple		
	<ol style="list-style-type: none"> <li><i>Hinge location (where applicable)</i> L = left hand R = right hand</li> <li><i>Finish type</i> L = laminate 1 = V1 2 = V2 3 = V3</li> <li><i>Interior Option</i> W = wood (shelves match case finish and drawer interiors cherry veneer)</li> <li><i>Pull Option (where applicable)</i> D = metal D-pull (finish optional) J = routed J-pull (finish matches case) C = nickel finish C-pull (nickel finish only) S = S-pull (stainless steel finish only) R = Cylinder T = Tab F = Bar H = Out Line</li> <li><i>Lock option (where applicable)</i> Optional hinged door configurations only Drawers always lock drilled L = drilled to accept lock N = no drilling</li> <li><i>Cabinet finish</i></li> <li><i>Optional pull finish where applicable</i></li> <li><i>Optional drilling to support workwall, left side</i> N = no drilling S0 = 19"h x 15"d S1 = 19"h x 20"d T0 = 23"h x 15"d T1 = 23"h x 20"d</li> <li><i>Optional drilling to support workwall, right side</i> *drilling options same as #8 above</li> </ol>	<p>Cabinets on this page are engineered to align with front sets of 28<sup>3</sup>/<sub>8</sub>"h pedestals and are intended for "desk height" planning applications. <b>Do not mix products from 26 1/2" h (standard height) planning model with 28 3/8" h (desk height) planning model in any one configuration.</b></p> <p><b>75" nominal height - actual height 75.125"</b></p> <p>Shelf adjustability is 2.5" up or down per shelf from equal drilled spacing.</p> <p>File drawers include file bars for front to back and side to side filing.</p> <p>File drawers support bottom loading.</p> <p>Coat rods and boots trays for wardrobe cabinets not included. Order separately, see page 420.</p> <p>These 75" cabinets are intended to be used with the overdesk units only.</p>
Applicable finishes are listed on page 5 and 6.	<p>Cabinets do not come with lock included. Keying instructions must accompany all cabinet orders, refer to page 523. Random locks are factory installed. Key-alike are field installed using the KnollKey order form.</p> <p>Product on this page excluding J-pull option will accept woodgrain laminate where laminate is currently an option. List price for woodgrain laminate options will be current published laminate list price plus 10%.</p>	

# Cabinets, 28<sup>3</sup>/<sub>8</sub>" planning 75" high, wood interiors

description	w	d	h	pattern no.	wood	wood	wood	wood
					interiors L	interiors V1	interiors V2	interiors V3
Storage w/4 file drwrs& hinged doors above (for desk height planning)	30"	20"	75"	RC732DHF ( ) ( ) L ( ) ( ) ( )	\$3,366.	\$4,408.	\$5,071.	\$6,846.
	30"	24"	75"	RC733DHF ( ) ( ) L ( ) ( ) ( )	3,723.	4,879.	5,609.	7,571.
	36"	20"	75"	RC762DHF ( ) ( ) L ( ) ( ) ( )	3,702.	4,852.	5,596.	7,555.
	36"	24"	75"	RC763DHF ( ) ( ) L ( ) ( ) ( )	4,092.	5,361.	6,172.	8,332.

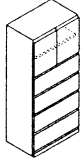

Requires two lock cores per cabinet

Order Code	Specification Information	Application Notes
Example: <b>RC732DHB(2)(W)(V316)</b>	<i>To order please specify pattern number including:</i>	
<b>R</b> Reff		
<b>C</b> Cabinet		
<b>7</b> 75" h (nominal)		
<b>3</b> 30" w (nominal)		
<b>2</b> 20" d (nominal)		
<b>DH</b> Desk height		
<b>B</b> Open bookcase		
<b>2</b> Finish type, V2		
<b>W</b> Interior option, wood		
<b>V316</b> Finish, light maple		
	<ol style="list-style-type: none"> <li><i>Hinge location (where applicable)</i> L = left hand R = right hand</li> <li><i>Finish type</i> L = laminate 1 = V1 2 = V2 3 = V3</li> <li><i>Interior Option</i> W = wood (shelves match case finish and drawer interiors cherry veneer)</li> <li><i>Pull Option (where applicable)</i> D = metal D-pull (finish optional) J = routed J-pull (finish matches case) C = nickel finish C-pull (nickel finish only) S = S-pull (stainless steel finish only) R = Cylinder T = Tab F = Bar H = Out Line</li> <li><i>Lock option (where applicable)</i> Optional hinged door configurations only Drawers always lock drilled L = drilled to accept lock N = no drilling</li> <li><i>Cabinet finish</i></li> <li><i>Optional pull finish where applicable</i></li> <li><i>Optional drilling to support workwall, left side</i> N = no drilling S0 = 19"h x 15"d S1 = 19"h x 20"d T0 = 23"h x 15"d T1 = 23"h x 20"d</li> <li><i>Optional drilling to support workwall, right side</i> *drilling options same as #8 above</li> </ol>	<p>Cabinets on this page are engineered to align with front sets of 28<sup>3</sup>/<sub>8</sub>" pedestals and are intended for "desk height" planning applications. <b>Do not mix products from 26 1/2" h (standard height) planning model with 28 3/8" h (desk height) planning model in any one configuration.</b></p> <p><b>75" nominal height - actual height 75.125"</b></p> <p>Shelf adjustability is 2.5" up or down per shelf from equal drilled spacing.</p> <p>File drawers include file bars for front to back and side to side filing.</p> <p>File drawers support bottom loading.</p> <p>Coat rods and boots trays for wardrobe cabinets not included. Order separately, see page 420.</p> <p>These 75" cabinets are intended to be used with the overdesk units only.</p>
	<p>Cabinets do not come with lock included. Keying instructions must accompany all cabinet orders, refer to page 523. Random locks are factory installed. Key-alike are field installed using the KnollKey order form.</p> <p>Product on this page excluding J-pull option will accept woodgrain laminate where laminate is currently an option. List price for woodgrain laminate options will be current published laminate list price plus 10%.</p>	

Applicable finishes are listed on page 5 and 6.

# Cabinets, 28<sup>3</sup>/<sub>8</sub>" planning 75" high, wood interiors

Reff Profiles

description	w	d	h	pattern no.	wood	wood	wood	wood
					interiors L	interiors V1	interiors V2	interiors V3
Cabinet with hinged doors for coat rod and boot tray	30"	20"	75"	RC732DHD ( ) W ( ) ( ) ( )	\$2,341.	\$3,069.	\$3,527.	\$4,762.
	30"	24"	75"	RC733DHD ( ) W ( ) ( ) ( )	2,573.	3,372.	3,877.	5,236.
	36"	20"	75"	RC762DHD ( ) W ( ) ( ) ( )	2,574.	3,374.	3,880.	5,241.
	36"	24"	75"	RC763DHD ( ) W ( ) ( ) ( )	2,829.	3,710.	4,266.	5,758.

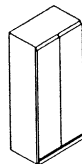

Requires one lock core per cabinet

Order Code	Specification Information	Application Notes
Example: <b>RC732DHB(2)(W)(V316)</b>	<i>To order please specify pattern number including:</i>	
<b>R</b> Reff		
<b>C</b> Cabinet		
<b>7</b> 75" h (nominal)	1. <i>Hinge location (where applicable)</i> L = left hand R = right hand	Cabinets on this page are engineered to align with front sets of 28 <sup>3</sup> / <sub>8</sub> " pedestals and are intended for "desk height" planning applications. <b>Do not mix products from 26 1/2" h (standard height) planning model with 28 3/8" h (desk height) planning model in any one configuration.</b>
<b>3</b> 30" w (nominal)	2. <i>Finish type</i> L = laminate 1 = V1 2 = V2 3 = V3	
<b>2</b> 20" d (nominal)	3. <i>Interior Option</i> W = wood (shelves match case finish and drawer interiors cherry veneer)	
<b>DH</b> Desk height	4. <i>Pull Option (where applicable)</i> D = metal D-pull (finish optional) J = routed J-pull (finish matches case) C = nickel finish C-pull (nickel finish only) S = S-pull (stainless steel finish only) R = Cylinder T = Tab F = Bar H = Out Line	
<b>B</b> Open bookcase	5. <i>Lock option (where applicable)</i> Optional hinged door configurations only Drawers always lock drilled L = drilled to accept lock N = no drilling	
<b>2</b> Finish type, V2	6. <i>Cabinet finish</i>	
<b>W</b> Interior option, wood	7. <i>Optional pull finish where applicable</i>	
<b>V316</b> Finish, light maple	8. <i>Optional drilling to support workwall, left side</i> N = no drilling S0 = 19"h x 15"d S1 = 19"h x 20"d T0 = 23"h x 15"d T1 = 23"h x 20"d	
	9. <i>Optional drilling to support workwall, right side</i> *drilling options same as #8 above	
		Shelf adjustability is 2.5" up or down per shelf from equal drilled spacing.
		File drawers include file bars for front to back and side to side filing.
		File drawers support bottom loading.
		Coat rods and boots trays for wardrobe cabinets not included. Order separately, see page 420.
		These 75" cabinets are intended to be used with the overdesk units only.
		Cabinets do not come with lock included. Keying instructions must accompany all cabinet orders, refer to page 523. Random locks are factory installed. Key-alike are field installed using the KnollKey order form.
		Product on this page excluding J-pull option will accept woodgrain laminate where laminate is currently an option. List price for woodgrain laminate options will be current published laminate list price plus 10%.

Applicable finishes are listed on page 5 and 6.

# Cabinets, 28<sup>3</sup>/<sub>8</sub>" planning 86" high, metal interiors

Reff Profiles

description	w	d	h	pattern no.	metal interiors L	metal interiors V1	metal interiors V2	metal interiors V3
Cabinet, hinged doors/ shelves 4 file drawers	30"	20"	86"	<b>RC832DHF</b> ( ) ( ) ( ) ( ) ( )	\$3,540.	\$4,638.	\$5,336.	\$7,202.
	30"	24"	86"	<b>RC833DHF</b> ( ) ( ) ( ) ( ) ( )	3,931.	5,151.	5,926.	8,000.
	36"	20"	86"	<b>RC862DHF</b> ( ) ( ) ( ) ( ) ( )	3,910.	5,125.	5,893.	7,956.

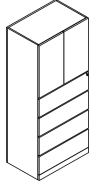

Cabinet, hinged doors/ shelves 2 file drawers	30"	20"	86"	<b>RC832DHG</b> ( ) ( ) ( )	3,266.	4,279.	4,919.	6,643.
	30"	24"	86"	<b>RC833DHG</b> ( ) ( ) ( )	3,591.	4,704.	5,411.	7,303.
	36"	20"	86"	<b>RC862DHG</b> ( ) ( ) ( )	3,544.	4,645.	5,344.	7,217.
	36"	24"	86"	<b>RC863DHG</b> ( ) ( ) ( )	3,872.	5,075.	5,836.	7,881.

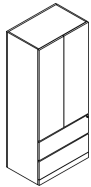

## Order Code

Example:	<b>RC732DHB(2)(M)(V316)</b>
<b>R</b>	Reff
<b>C</b>	Cabinet
<b>8</b>	86" h (nominal)
<b>3</b>	30" w (nominal)
<b>2</b>	20" d (nominal)
<b>DH</b>	Desk height
<b>2</b>	Finish type, V2
<b>M</b>	Interior option, metal
<b>V316</b>	Finish, light maple

Applicable finishes are listed on page 5 and 6.

## Specification Information

- To order please specify pattern number including:*
- Hinge location (where applicable)*  
L = left hand  
R = right hand
  - Finish type*  
L = laminate  
1 = V1  
2 = V2  
3 = V3
  - Interior Option*  
M = metal (metal shelves or metal drawers)  
(If laminate case finish- shelves painted to match; if V1, V2 or V3 case finish-shelves painted black; drawer interiors painted black metal)
  - Pull Option (where applicable)*  
D = metal D-pull (finish optional)  
J = routed J-pull (finish matches case)  
C = nickel finish C-pull (nickel finish only)  
S = S-pull (stainless steel finish only)  
R = Cylinder  
T = Tab  
F = Bar  
H = Out Line
  - Lock option (where applicable)*  
Optional hinged door configurations only  
Drawers always lock drilled  
L = drilled to accept lock  
N = no drilling

- Cabinet finish*
- Optional pull finish where applicable*

Cabinets do not come with lock included. Keying instructions must accompany all cabinet orders, refer to page 523.  
Random locks are factory installed. Key-alike are field installed using the KnollKey order form.

Product on this page excluding J-pull option will accept woodgrain laminate where laminate is currently an option.  
List price for woodgrain laminate options will be current published laminate list price plus 10%.

## Application Notes

Cabinets on this page are engineered to align with front sets of 28<sup>3</sup>/<sub>8</sub>" pedestals and are intended for "desk height" planning applications. **Do not mix products from 26 1/2" h (standard height) planning model with 28 3/8" h (desk height) planning model in any one configuration.**

**86" nominal height - actual height 85.500"**

Shelf adjustability is 2.5" up or down per shelf from equal drilled spacing.

File drawers include file bars for front to back and side to side filing.

File drawers support bottom loading.

Coat rods and boots trays for wardrobe cabinets not included. Order separately, see page 420.

# Cabinets, 28<sup>3</sup>/<sub>8</sub>" planning 86" high, metal interiors

Reff Profiles

description	w	d	h	pattern no.	metal	metal	metal	metal
					interiors L	interiors V1	interiors V2	interiors V3
Cabinet, double high with file/file below, top open with one adjustable shelf	30"	20"	86"	<b>RC832DHK</b> ( ) ( )	\$3,162.	\$4,150.	\$4,790.	\$6,466.
	30"	24"	86"	<b>RC833DHK</b> ( ) ( )	3,488.	4,572.	5,280.	7,127.
	36"	20"	86"	<b>RC862DHK</b> ( ) ( )	3,441.	4,515.	5,215.	7,040.
	36"	24"	86"	<b>RC863DHK</b> ( ) ( )	3,769.	4,944.	5,707.	7,704.

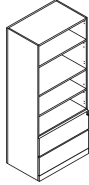

Cabinet, double high with 4 files below, top open with one adjustable shelf	30"	20"	86"	<b>RC832DHO</b> ( ) ( )	3,368.	4,466.	5,164.	7,030.
	30"	24"	86"	<b>RC833DHO</b> ( ) ( )	3,760.	4,979.	5,754.	7,829.
	36"	20"	86"	<b>RC862DHO</b> ( ) ( )	3,738.	4,953.	5,721.	7,784.
	36"	24"	86"	<b>RC863DHO</b> ( ) ( )	4,170.	5,516.	6,371.	8,661.

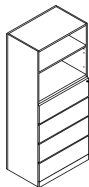

## Order Code

Example:	<b>RC732DHB(2)(M)(V316)</b>
<b>R</b>	Reff
<b>C</b>	Cabinet
<b>8</b>	86" h (nominal)
<b>3</b>	30" w (nominal)
<b>2</b>	20" d (nominal)
<b>DH</b>	Desk height
<b>2</b>	Finish type, V2
<b>M</b>	Interior option, metal
<b>V316</b>	Finish, light maple

## Specification Information

- To order please specify pattern number including:
- Hinge location (where applicable)**  
L = left hand  
R = right hand
  - Finish type**  
L = laminate  
1 = V1  
2 = V2  
3 = V3
  - Interior Option**  
M = metal (metal shelves or metal drawers)  
(If laminate case finish- shelves painted to match; if V1, V2 or V3 case finish-shelves painted black; drawer interiors painted black metal)
  - Pull Option (where applicable)**  
D = metal D-pull (finish optional)  
J = routed J-pull (finish matches case)  
C = nickel finish C-pull (nickel finish only)  
S = S-pull (stainless steel finish only)  
R = Cylinder  
T = Tab  
F = Bar  
H = Out Line
  - Lock option (where applicable)**  
Optional hinged door configurations only  
Drawers always lock drilled  
L = drilled to accept lock  
N = no drilling

## Application Notes

- Cabinet finish**
- Optional pull finish where applicable**

Cabinets do not come with lock included. Keying instructions must accompany all cabinet orders, refer to page 523.  
Random locks are factory installed. Key-alike are field installed using the KnollKey order form.

Product on this page excluding J-pull option will accept woodgrain laminate where laminate is currently an option.  
List price for woodgrain laminate options will be current published laminate list price plus 10%.

Cabinets on this page are engineered to align with front sets of 28<sup>3</sup>/<sub>8</sub>" pedestals and are intended for "desk height" planning applications. **Do not mix products from 26 1/2" h (standard height) planning model with 28 3/8" h (desk height) planning model in any one configuration.**

**86" nominal height - actual height 85.500"**

Shelf adjustability is 2.5" up or down per shelf from equal drilled spacing.

File drawers include file bars for front to back and side to side filing.

File drawers support bottom loading.

Coat rods and boots trays for wardrobe cabinets not included. Order separately, see page 420.

Applicable finishes are listed on page 5 and 6.



# Cabinets, 28<sup>3</sup>/<sub>8</sub>" planning 86" high, metal interiors

description	w	d	h	pattern no.	metal	metal	metal	metal
					interiors L	interiors V1	interiors V2	interiors V3
Cabinet, wardrobe/ bookcase combo full height doors	30"	20"	86"	<b>RC832DHEH(L/R)( ) ( ) ( ) ( )</b>	\$3,295.	\$4,322.	\$4,965.	\$6,704.
	30"	24"	86"	<b>RC833DHEH(L/R)( ) ( ) ( ) ( )</b>	3,652.	4,791.	5,505.	7,433.
	36"	20"	86"	<b>RC862DHEH(L/R)( ) ( ) ( ) ( )</b>	3,587.	4,703.	5,405.	7,298.
	36"	24"	86"	<b>RC863DHEH(L/R)( ) ( ) ( ) ( )</b>	3,973.	5,210.	5,988.	8,085.

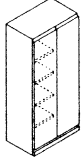

Left hand shown

Order Code	Specification Information	Application Notes
Example: <b>RC732DHB(2)(M)(V316)</b>	<i>To order please specify pattern number including:</i>	
<b>R</b> Reff	6. <i>Cabinet finish</i>	Cabinets on this page are engineered to align with front sets of 28 <sup>3</sup> / <sub>8</sub> "h pedestals and are intended for "desk height" planning applications. <b>Do not mix products from 26 1/2"h (standard height) planning model with 28 3/8"h (desk height) planning model in any one configuration.</b>
<b>C</b> Cabinet	7. <i>Optional pull finish where applicable</i>	
<b>8</b> 86" h (nominal)	1. <i>Hinge location (where applicable)</i> L = left hand R = right hand	<b>86" nominal height - actual height 85.500"</b>
<b>3</b> 30" w (nominal)	2. <i>Finish type</i> L = laminate 1 = V1 2 = V2 3 = V3	
<b>2</b> 20" d (nominal)	3. <i>Interior Option</i> M = metal (metal shelves or metal drawers) (If laminate case finish- shelves painted to match; if V1,V2 or V3 case finish-shelves painted black; drawer interiors painted black metal)	Shelf adjustability is 2.5" up or down per shelf from equal drilled spacing.
<b>DH</b> Desk height	4. <i>Pull Option (where applicable)</i> D = metal D-pull (finish optional) J = routed J-pull (finish matches case) C = nickel finish C-pull (nickel finish only) S = S-pull (stainless steel finish only) R = Cylinder T = Tab F = Bar H = Out Line	
<b>2</b> Finish type, V2	5. <i>Lock option (where applicable)</i> Optional hinged door configurations only Drawers always lock drilled L = drilled to accept lock N = no drilling	File drawers include file bars for front to back and side to side filing.
<b>M</b> Interior option, metal		File drawers support bottom loading.
<b>V316</b> Finish, light maple		Coat rods and boots trays for wardrobe cabinets not included. Order separately, see page 420.

Applicable finishes are listed on page 5 and 6.

# Cabinets, 28<sup>3</sup>/<sub>8</sub>" planning 86" high, wood interiors

Reff Profiles

description	w	d	h	pattern no.	wood interiors L	wood interiors V1	wood interiors V2	wood interiors V3
Cabinet, hinged doors/ shelves 4 file drawers	30"	20"	86"	<b>RC832DHF</b> ( ) ( ) ( ) ( ) ( )	\$3,702.	\$4,848.	\$5,579.	\$7,531.
	30"	24"	86"	<b>RC833DHF</b> ( ) ( ) ( ) ( ) ( )	4,095.	5,366.	6,170.	8,329.
	36"	20"	86"	<b>RC862DHF</b> ( ) ( ) ( ) ( ) ( )	4,072.	5,337.	6,155.	8,310.

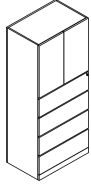

Cabinet, hinged doors/ shelves 2 file drawers	30"	20"	86"	<b>RC832DHG</b> ( ) ( )	3,427.	4,488.	5,164.	6,970.
	30"	24"	86"	<b>RC833DHG</b> ( ) ( )	3,751.	4,916.	5,653.	7,631.
	36"	20"	86"	<b>RC862DHG</b> ( ) ( )	3,706.	4,859.	5,586.	7,542.
	36"	24"	86"	<b>RC863DHG</b> ( ) ( )	4,034.	5,287.	6,081.	8,210.

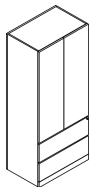

Order Code	Specification Information	Application Notes
<p>Example: <b>RC832DHB(2)(W)(V316)</b></p> <p><b>R</b> Reff</p> <p><b>C</b> Cabinet</p> <p><b>8</b> 86" h (nominal)</p> <p><b>3</b> 30" w (nominal)</p> <p><b>2</b> 20" d (nominal)</p> <p><b>DH</b> Desk height</p> <p><b>2</b> Finish type, V2</p> <p><b>W</b> Interior option, wood</p> <p><b>V316</b> Finish, light maple</p>	<p>To order please specify pattern number including:</p> <ol style="list-style-type: none"> <li><b>Hinge location (where applicable)</b> L = left hand R = right hand</li> <li><b>Finish type</b> L = laminate 1 = V1 2 = V2 3 = V3</li> <li><b>Interior Option</b> W = wood (shelves match case finish and drawer interiors cherry veneer)</li> <li><b>Pull Option (where applicable) optional)</b> D = metal D-pull (finish matches case) J = routed J-pull (finish matches case) C = nickel finish C-pull (nickel finish only) S = S-pull (stainless steel finish only) R = Cylinder T = Tab F = Bar H = Out Line</li> <li><b>Lock option (where applicable)</b> Optional hinged door configurations only Drawers always lock drilled L = drilled to accept lock N = no drilling</li> </ol>	<p>6. <b>Cabinet finish</b></p> <p>7. <b>Optional pull finish where applicable</b></p> <p>Cabinets do not come with lock included. Keying instructions must accompany all cabinet orders, refer to page 523. Random locks are factory installed. Key-alike are field installed using the KnollKey order form.</p> <p>Product on this page excluding J-pull option will accept woodgrain laminate where laminate is currently an option. List price for woodgrain laminate options will be current published laminate list price plus 10%.</p> <p>Cabinets on this page are engineered to align with front sets of 28<sup>3</sup>/<sub>8</sub>" pedestals and are intended for "desk height" planning applications. <b>Do not mix products from 26 1/2" h (standard height) planning model with 28 3/8" h (desk height) planning model in any one configuration.</b></p> <p><b>86" nominal height - actual height 85.500"</b></p> <p>Shelf adjustability is 2.5" up or down per shelf from equal drilled spacing.</p> <p>File drawers include file bars for front to back and side to side filing.</p> <p>File drawers support bottom loading.</p> <p>Coat rods and boots trays for wardrobe cabinets not included. Order separately, see page 420.</p>

Applicable finishes are listed on page 5 and 6.

# Cabinets, 28<sup>3</sup>/<sub>8</sub>" planning 86" high, wood interiors

Reff Profiles

description	w	d	h	pattern no.	wood	wood	wood	wood
					interiors L	interiors V1	interiors V2	interiors V3
Cabinet, double high with file/file below, top open with one adjustable shelf	30"	20"	86"	RC832DHK( ) ( )	\$3,324.	\$4,358.	\$5,032.	\$6,793.
	30"	24"	86"	RC833DHK( ) ( )	3,648.	4,784.	5,524.	7,457.
	36"	20"	86"	RC862DHK( ) ( )	3,603.	4,729.	5,458.	7,370.
	36"	24"	86"	RC863DHK( ) ( )	3,930.	5,157.	5,950.	8,033.

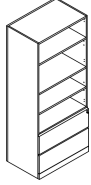

Cabinet, double high with 4 files below, top open with one adjustable shelf	30"	20"	86"	RC832DHO( ) ( )	3,546.	4,692.	5,423.	7,374.
	30"	24"	86"	RC833DHO( ) ( )	3,939.	5,210.	6,013.	8,172.
	36"	20"	86"	RC862DHO( ) ( )	3,916.	5,181.	5,999.	8,154.
	36"	24"	86"	RC863DHO( ) ( )	4,345.	5,741.	6,632.	9,009.

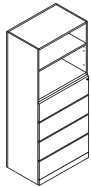

Cabinet, with shelving	30"	20"	86"	RC832DHB( ) ( )	2,304.	3,034.	3,491.	5,140.
	30"	24"	86"	RC833DHB( ) ( )	2,551.	3,343.	3,843.	5,658.
	36"	20"	86"	RC862DHB( ) ( )	2,602.	3,408.	3,920.	5,772.
	36"	24"	86"	RC863DHB( ) ( )	2,833.	3,716.	4,272.	6,292.

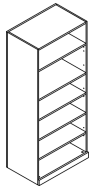

Order Code	Specification Information	Application Notes
<p>Example: <b>RC832DHB(2)(W)(V316)</b></p> <p><b>R</b> Reff</p> <p><b>C</b> Cabinet</p> <p><b>8</b> 86" h (nominal)</p> <p><b>3</b> 30" w (nominal)</p> <p><b>2</b> 20" d (nominal)</p> <p><b>DH</b> Desk height</p> <p><b>2</b> Finish type, V2</p> <p><b>W</b> Interior option, wood</p> <p><b>V316</b> Finish, light maple</p>	<p>To order please specify pattern number including:</p> <ol style="list-style-type: none"> <li>Hinge location (where applicable) <ul style="list-style-type: none"> <li>L = left hand</li> <li>R = right hand</li> </ul> </li> <li>Finish type <ul style="list-style-type: none"> <li>L = laminate</li> <li>1 = V1</li> <li>2 = V2</li> <li>3 = V3</li> </ul> </li> <li>Interior Option <ul style="list-style-type: none"> <li>W = wood (shelves match case finish and drawer interiors cherry veneer)</li> </ul> </li> <li>Pull Option (where applicable) <ul style="list-style-type: none"> <li>D = metal D-pull (finish optional)</li> <li>J = routed J-pull (finish matches case)</li> <li>C = nickel finish C-pull (nickel finish only)</li> <li>S = S-pull (stainless steel finish only)</li> <li>R = Cylinder</li> <li>T = Tab</li> <li>F = Bar</li> <li>H = Out Line</li> </ul> </li> <li>Lock option (where applicable) <ul style="list-style-type: none"> <li>Optional hinged door configurations only</li> <li>Drawers always lock drilled</li> <li>L = drilled to accept lock</li> <li>N = no drilling</li> </ul> </li> </ol>	<p>6. Cabinet finish</p> <p>7. Optional pull finish where applicable</p> <p>Cabinets do not come with lock included. Keying instructions must accompany all cabinet orders, refer to page 523. Random locks are factory installed. Key-alike are field installed using the KnollKey order form.</p> <p>Product on this page excluding J-pull option will accept woodgrain laminate where laminate is currently an option. List price for woodgrain laminate options will be current published laminate list price plus 10%.</p> <p>Cabinets on this page are engineered to align with front sets of 28<sup>3</sup>/<sub>8</sub>"h pedestals and are intended for "desk height" planning applications. <b>Do not mix products from 26<sup>1</sup>/<sub>2</sub>"h (standard height) planning model with 28<sup>3</sup>/<sub>8</sub>"h (desk height) planning model in any one configuration.</b></p> <p><b>86" nominal height - actual height 85.500"</b></p> <p>Shelf adjustability is 2.5" up or down per shelf from equal drilled spacing.</p> <p>File drawers include file bars for front to back and side to side filing.</p> <p>File drawers support bottom loading.</p> <p>Coat rods and boots trays for wardrobe cabinets not included. Order separately, see page 420.</p>

Applicable finishes are listed on page 5 and 6.

# Cabinets, 28<sup>3</sup>/<sub>8</sub>" planning 86" high, wood interiors

Reff Profiles

description	w	d	h	pattern no.	wood	wood	wood	wood
					interiors L	interiors V1	interiors V2	interiors V3
Cabinet, wardrobe/ bookcase combo full height doors	30"	20"	86"	<b>RC832DHEH(L/R)( ) ( ) ( ) ( )</b>	\$3,472.	\$4,551.	\$5,234.	\$7,065.
	30"	24"	86"	<b>RC833DHEH(L/R)( ) ( ) ( ) ( )</b>	3,865.	5,067.	5,827.	7,866.
	36"	20"	86"	<b>RC862DHEH(L/R)( ) ( ) ( ) ( )</b>	3,793.	4,970.	5,717.	7,718.
	36"	24"	86"	<b>RC863DHEH(L/R)( ) ( ) ( ) ( )</b>	4,218.	5,528.	6,359.	8,584.

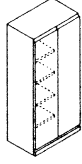

Left hand shown

Requires one lock core per cabinet  
Shelves painted metal

Order Code	Specification Information	Application Notes
Example: <b>RC832DHB(2)(W)(V316)</b>	<i>To order please specify pattern number including:</i>	
<b>R</b> Reff	6. <i>Cabinet finish</i>	Cabinets on this page are engineered to align with front sets of 28 <sup>3</sup> / <sub>8</sub> "h pedestals and are intended for "desk height" planning applications. <b>Do not mix products from 26<sup>1</sup>/<sub>2</sub>"h (standard height) planning model with 28<sup>3</sup>/<sub>8</sub>"h (desk height) planning model in any one configuration.</b>
<b>C</b> Cabinet	7. <i>Optional pull finish where applicable</i>	
<b>8</b> 86" h (nominal)	1. <i>Hinge location (where applicable)</i> L = left hand R = right hand	Cabinets do not come with lock included. Keying instructions must accompany all cabinet orders, refer to page 523. Random locks are factory installed. Key-alike are field installed using the KnollKey order form.
<b>3</b> 30" w (nominal)	2. <i>Finish type</i> L = laminate 1 = V1 2 = V2 3 = V3	Product on this page excluding J-pull option will accept woodgrain laminate where laminate is currently an option. List price for woodgrain laminate options will be current published laminate list price plus 10%.
<b>2</b> 20" d (nominal)	3. <i>Interior Option</i> W = wood (shelves match case finish and drawer interiors cherry veneer)	<b>86" nominal height - actual height 85.500"</b>
<b>DH</b> Desk height	4. <i>Pull Option (where applicable)</i> D = metal D-pull (finish optional) J = routed J-pull (finish matches case) C = nickel finish C-pull (nickel finish only) S = S-pull (stainless steel finish only) R = Cylinder T = Tab F = Bar H = Out Line	Shelf adjustability is 2.5" up or down per shelf from equal drilled spacing.
<b>2</b> Finish type, V2	5. <i>Lock option (where applicable)</i> Optional hinged door configurations only Drawers always lock drilled L = drilled to accept lock N = no drilling	File drawers include file bars for front to back and side to side filing.
<b>W</b> Interior option, wood		File drawers support bottom loading.
<b>V316</b> Finish, light maple		Coat rods and boots trays for wardrobe cabinets not included. Order separately, see page 420.

Applicable finishes are listed on page 5 and 6.

Cabinets Progressive  
49" high, metal interior  
28<sup>3/8</sup>" high planning

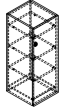
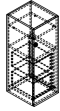
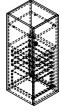
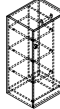
description	d	w	h	pattern no.	L/L	L/V1	L/V2	L/V3	V1/V1	V2/V2	V3/V3
Cabinets, hinge door with shelves 	20"	18"	49"	<b>RCFS4912C(L/R)M</b> ( ) ( ) ( ) ( ) ( )	\$1,738.	\$1,911.	\$1,998.	\$2,085.	\$2,640.	\$3,036.	\$3,946.
	24"	18"	49"	<b>RCFS4913C(L/R)M</b> ( ) ( ) ( ) ( ) ( )	1,790.	1,969.	2,058.	2,148.	2,730.	3,140.	4,082.
Cabinets, hinge door with shelves&File/File 	20"	18"	49"	<b>RCFS4912Y(L/R)M</b> ( ) ( ) ( ) ( ) ( )	2,239.	2,463.	2,574.	2,686.	3,358.	3,862.	5,020.
	24"	18"	49"	<b>RCFS4913Y(L/R)M</b> ( ) ( ) ( ) ( ) ( )	2,310.	2,541.	2,657.	2,772.	3,465.	3,985.	5,181.
Cabinets, hinge door with shelves&Box/File/File 	20"	18"	49"	<b>RCFS4912Z(L/R)M</b> ( ) ( ) ( ) ( ) ( )	2,313.	2,544.	2,660.	2,776.	3,470.	3,990.	5,187.
	24"	18"	49"	<b>RCFS4913Z(L/R)M</b> ( ) ( ) ( ) ( ) ( )	2,388.	2,627.	2,747.	2,866.	3,583.	4,210.	5,356.
Cabinets, hinge door with shelves&wardrobe 	20"	24"	49"	<b>RCFS4932V(L/R)M</b> ( ) ( ) ( ) ( ) ( )	2,079.	2,287.	2,391.	2,495.	3,227.	3,711.	4,825.
	24"	24"	49"	<b>RCFS4933V(L/R)M</b> ( ) ( ) ( ) ( ) ( )	2,144.	2,358.	2,465.	2,573.	3,349.	3,852.	5,000.

Order Code	Specification Information	Application Notes
Example: <b>RCFS4912C(L/R)M</b> ( ) ( ) ( ) ( ) ( )	<i>To order please specify pattern number including:</i>	Configurations;
<b>R</b> Reff	1. Lock	C = all shelves for 18" w cabinets
<b>C</b> Cabinet	L=Drill for lock	Y = hinge door with shelves and FF -18" w
<b>FS</b> Free Standing	N=No lock	Z = hinge door with shelves BB for 18" w
<b>49</b> Height	2. Lock finish	V = all shelves for 24" w cabinets
<b>1</b> 18" Wide	S=Silver	W = hinge door with shelves and FF and wardrobe for 24" w
<b>2</b> 20" d (nominal)	B=Black	X = hinge door with shelves and BB and wardrobe for 24" w
<b>C</b> Hinge door with shelves	3. Pull options	The images on this page are shown as a right hand cabinets.
<b>L/R</b> Left/Right hinge	Grommet	From the users perspective, if the hinges are on the right side, the cabinet is classified as "right hand" cabinet.
<b>M</b> Metal interior	4. Pull finish	
<b>N</b> Lock	Paint / Plated	
<b>S</b> Lock finish	5. Case finish	
<b>G</b> Pull option	L, V1, V2, V3	
<b>115</b> Pull finish option	6. Door finish	
<b>114</b> Case finish	L, V1, V2, V3	
<b>115</b> Door finish		

Applicable finishes are listed on page 5 and 6.

Cabinets Progressive  
 49" high, metal interior  
 28<sup>3</sup>/<sub>8</sub>" high planning

description	d	w	h	pattern no.	L/L	L/V1	L/V2	L/V3	V1/V1	V2/V2	V3/V3
Cabinets, hinge door with shelves, File/File&wardrobe	20"	24"	49"	<b>RCFS4932W(L/R)M</b> ( ) ( ) ( ) ( ) ( )	\$2,403.	\$2,643.	\$2,763.	\$2,883.	\$3,722.	\$4,281.	\$5,565.
	24"	24"	49"	<b>RCFS4933W(L/R)M</b> ( ) ( ) ( ) ( ) ( )	2,473.	2,720.	2,844.	2,968.	3,853.	4,431.	5,760.

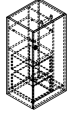

Cabinets, hinge door with shelves, Box/Box/File&wardrobe	20"	24"	49"	<b>RCFS4932X(L/R)M</b> ( ) ( ) ( ) ( ) ( )	2,554.	2,810.	2,937.	3,065.	3,882.	4,464.	5,803.
	24"	24"	49"	<b>RCFS4933X(L/R)M</b> ( ) ( ) ( ) ( ) ( )	2,630.	3,893.	3,024.	3,156.	4,018.	4,620.	6,006.

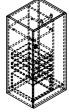

Order Code	Specification Information	Application Notes
Example: <b>RCFS4912C(L/R)M</b> ( ) ( ) ( ) ( ) ( )	<i>To order please specify pattern number including:</i>	Configurations;
<b>R</b> Reff	1. Lock L=Drill for lock N=No lock	C = all shelves for 18" w cabinets
<b>C</b> Cabinet	2. Lock finish S=Silver B=Black	Y = hinge door with shelves and FF -18" w
<b>FS</b> Free Standing	3. Pull options Grommet	Z = hinge door with shelves BB for 18" w
<b>49</b> Height	4. Pull finish Paint / Plated	V = all shelves for 24" w cabinets
<b>1</b> 18" Wide	5. Case finish L, V1, V2, V3	W = hinge door with shelves and FF and wardrobe for 24" w
<b>2</b> 20" d (nominal)	6. Door finish L, V1, V2, V3	X = hinge door with shelves and BB and wardrobe for 24" w
<b>C</b> Hinge door with shelves		The images on this page are shown as a right hand cabinets.
<b>L/R</b> Left/Right hinge		From the users perspective, if the hinges are on the right side, the cabinet is classified as "right hand" cabinet.
<b>M</b> Metal interior		
<b>N</b> Lock		
<b>S</b> Lock finish		
<b>G</b> Pull option		
<b>115</b> Pull finish option		
<b>114</b> Case finish		
<b>115</b> Door finish		

Applicable finishes are listed on page 5 and 6.

Cabinets Progressive  
 64" high, metal interior  
 28<sup>3/8</sup>" high planning

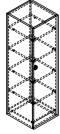
description	d	w	h	pattern no.	L/L	L/V1	L/V2	L/V3	V1/V1	V2/V2	V3/V3
Cabinet, hinge door with shelves 	20"	18"	64"	<b>RCFS6412C(L/R)M</b> ( ) ( ) ( ) ( ) ( )	\$1,887.	\$2,075.	\$2,170.	\$2,264.	\$2,889.	\$3,323.	\$4,319.
	24"	18"	64"	<b>RCFS6413C(L/R)M</b> ( ) ( ) ( ) ( ) ( )	1,952.	2,147.	2,245.	2,342.	3,017.	3,470.	4,511.

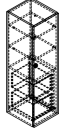
Cabinets, hinge door with shelves&File/File 	20"	18"	64"	<b>RCFS6412Y(L/R)M</b> ( ) ( ) ( ) ( ) ( )	2,411.	2,652.	2,773.	2,893.	3,617.	4,159.	5,407.
	24"	18"	64"	<b>RCFS6413Y(L/R)M</b> ( ) ( ) ( ) ( ) ( )	2,545.	2,800.	2,927.	3,055.	3,818.	4,391.	5,708.

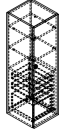
Cabinets, hinge door with shelves&Box/File/File 	20"	18"	64"	<b>RCFS6412Z(L/R)M</b> ( ) ( ) ( ) ( ) ( )	2,486.	2,735.	2,859.	2,983.	3,729.	4,288.	5,575.
	24"	18"	64"	<b>RCFS6413Z(L/R)M</b> ( ) ( ) ( ) ( ) ( )	2,624.	2,886.	3,017.	3,149.	3,936.	4,526.	5,884.

Order Code	Specification Information	Application Notes
Example: <b>RCFS6412C(L/R)M</b> ( ) ( ) ( ) ( ) ( )	<i>To order please specify pattern number including:</i>	Configurations;
<b>R</b> Reff	1. Lock	C = all shelves for 18" w cabinets
<b>C</b> Cabinet	L=Drill for lock	Y = hinge door with shelves and FF -18" w
<b>FS</b> Free Standing	N=No lock	Z = hinge door with shelves BB for 18" w
<b>64</b> Height	2. Lock finish	V = all shelves for 24" w cabinets
<b>1</b> 18" Wide	S=Silver	W = hinge door with shelves and FF and wardrobe for 24" w
<b>2</b> 20" d (nominal)	B=Black	X = hinge door with shelves and BB and wardrobe for 24" w
<b>C</b> Hinge door with shelves	3. Pull options	The images on this page are shown as a right hand cabinets.
<b>L/R</b> Left/Right hinge	Grommet	From the users perspective, if the hinges are on the right side, the cabinet is classified as "right hand" cabinet.
<b>M</b> Metal interior	4. Pull finish	
<b>N</b> Lock	Paint / Plated	
<b>S</b> Lock finish	5. Case finish	
<b>G</b> Pull option	L, V1, V2, V3	
<b>115</b> Pull finish option	6. Door finish	
<b>114</b> Case finish	L, V1, V2, V3	
<b>115</b> Door finish		

Applicable finishes are listed on page 5 and 6.

Cabinets Progressive  
 64" high, metal interior  
 28<sup>3/8</sup>" high planning

description	d	w	h	pattern no.	L/L	L/V1	L/V2	L/V3	V1/V1	V2/V2	V3/V3
Cabinets, hinge door with shelves&wardrobe	20"	24"	64"	<b>RCFS6432V(L/R)M</b> ( ) ( ) ( ) ( ) ( )	\$2,245.	\$2,470.	\$2,582.	\$2,695.	\$3,542.	\$4,074.	\$5,296.
	24"	24"	64"	<b>RCFS6433V(L/R)M</b> ( ) ( ) ( ) ( ) ( )	2,326.	2,559.	2,675.	2,791.	3,715.	4,273.	5,554.

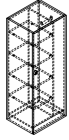

Cabinets, hinge door with shelves, File/File&wardrobe	20"	24"	64"	<b>RCFS6432W(L/R)M</b> ( ) ( ) ( ) ( ) ( )	2,569.	2,826.	2,954.	3,083.	4,037.	4,643.	6,036.
	24"	24"	64"	<b>RCFS6433W(L/R)M</b> ( ) ( ) ( ) ( ) ( )	2,724.	2,996.	3,133.	3,269.	4,283.	4,926.	6,404.

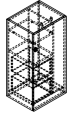

Cabinets, hinge door with shelves, Box/Box/File&wardrobe	20"	24"	64"	<b>RCFS6432X(L/R)M</b> ( ) ( ) ( ) ( ) ( )	2,721.	2,993.	3,129.	3,265.	4,197.	4,826.	6,274.
	24"	24"	64"	<b>RCFS6433X(L/R)M</b> ( ) ( ) ( ) ( ) ( )	2,881.	3,169.	3,313.	3,457.	4,448.	5,115.	6,649.

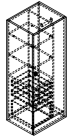

Order Code	Specification Information	Application Notes
Example: <b>RCFS6412C(L/R)M</b> ( ) ( ) ( ) ( ) ( )	<i>To order please specify pattern number including:</i>	Configurations;
<b>R</b> Reff	1. Lock	C = all shelves for 18" w cabinets
<b>C</b> Cabinet	L=Drill for lock	Y = hinge door with shelves and FF -18" w
<b>FS</b> Free Standing	N=No lock	Z = hinge door with shelves BB for 18" w
<b>64</b> Height	2. Lock finish	V = all shelves for 24" w cabinets
<b>1</b> 18" Wide	S=Silver	W = hinge door with shelves and FF and wardrobe for 24" w
<b>2</b> 20" d (nominal)	B=Black	X = hinge door with shelves and BB and wardrobe for 24" w
<b>C</b> Hinge door with shelves	3. Pull options	The images on this page are shown as a right hand cabinets.
<b>L/R</b> Left/Right hinge	Grommet	From the users perspective, if the hinges are on the right side, the cabinet is classified as "right hand" cabinet.
<b>M</b> Metal interior	4. Pull finish	
<b>N</b> Lock	Paint / Plated	
<b>S</b> Lock finish	5. Case finish	
<b>G</b> Pull option	L, V1, V2, V3	
<b>115</b> Pull finish option	6. Door finish	
<b>114</b> Case finish	L, V1, V2, V3	
<b>115</b> Door finish		

Applicable finishes are listed on page 5 and 6.

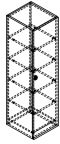

Cabinets Progressive  
68" high, metal interior  
28<sup>3/8</sup>" high planning

description	d	w	h	pattern no.	L/L	L/V1	L/V2	L/V3	V1/V1	V2/V2	V3/V3
Cabinets, hinge door with shelves 	20"	18"	68"	<b>RCFS6812C(L/R)M</b> ( ) ( ) ( ) ( ) ( )	\$1,908.	\$2,099.	\$2,195.	\$2,290.	\$2,957.	\$3,401.	\$4,421.
	24"	18"	68"	<b>RCFS6813C(L/R)M</b> ( ) ( ) ( ) ( ) ( )	1,975.	2,173.	2,272.	2,370.	3,078.	3,540.	4,602.

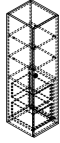
Cabinets, hinge door with shelves&File/File 	20"	18"	68"	<b>RCFS6812Y(L/R)M</b> ( ) ( ) ( ) ( ) ( )	2,462.	2,709.	2,832.	2,955.	3,694.	4,248.	5,522.
	24"	18"	68"	<b>RCFS6813Y(L/R)M</b> ( ) ( ) ( ) ( ) ( )	2,592.	2,852.	2,981.	3,111.	3,888.	4,472.	5,813.

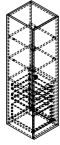
Cabinets, hinge door with shelves&Box/File/File 	20"	18"	68"	<b>RCFS6812Z(L/R)M</b> ( ) ( ) ( ) ( ) ( )	2,537.	2,791.	2,918.	3,045.	3,806.	4,377.	5,690.
	24"	18"	68"	<b>RCFS6813Z(L/R)M</b> ( ) ( ) ( ) ( ) ( )	2,671.	2,938.	3,071.	3,205.	4,006.	4,607.	5,989.

Order Code	Specification Information	Application Notes
Example: <b>RCFS6812C(L/R)M</b> ( ) ( ) ( ) ( ) ( )	<i>To order please specify pattern number including:</i>	Configurations;
<b>R</b> Reff	1. Lock	C = all shelves for 18" w cabinets
<b>C</b> Cabinet	L=Drill for lock	Y = hinge door with shelves and FF -18" w
<b>FS</b> Free Standing	N=No lock	Z = hinge door with shelves BB for 18" w
<b>68</b> Height	2. Lock finish	V = all shelves for 24" w cabinets
<b>1</b> 18" Wide	S=Silver	W = hinge door with shelves and FF and wardrobe for 24" w
<b>2</b> 20" d (nominal)	B=Black	X = hinge door with shelves and BB and wardrobe for 24" w
<b>C</b> Hinge door with shelves	3. Pull options	The images on this page are shown as a right hand cabinets.
<b>L/R</b> Left/Right hinge	Grommet	From the users perspective, if the hinges are on the right side, the cabinet is classified as "right hand" cabinet.
<b>M</b> Metal interior	4. Pull finish	
<b>L</b> Lock	Paint / Plated	
<b>S</b> Lock finish	5. Case finish	
<b>G</b> Pull option	L, V1, V2, V3	
<b>115</b> Pull finish option	6. Door finish	
<b>114</b> Case finish	L, V1, V2, V3	
<b>115</b> Door finish		

Applicable finishes are listed on page 5 and 6.

Cabinets Progressive  
68" high, metal interior  
28<sup>3/8</sup>" high planning

description	d	w	h	pattern no.	L/L	L/V1	L/V2	L/V3	V1/V1	V2/V2	V3/V3
Cabinets, hinge door with shelves&wardrobe	20"	24"	68"	<b>RCFS6832V(L/R)M</b> ( ) ( ) ( ) ( ) ( )	\$2,274.	\$2,501.	\$2,615.	\$2,728.	\$3,630.	\$4,175.	\$5,427.
	24"	24"	68"	<b>RCFS6833V(L/R)M</b> ( ) ( ) ( ) ( ) ( )	2,356.	2,592.	2,710.	2,827.	3,800.	4,370.	5,681.

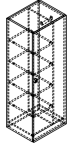

Cabinets, hinge door with shelves, File/File&wardrobe	20"	24"	68"	<b>RCFS6832W(L/R)M</b> ( ) ( ) ( ) ( ) ( )	2,607.	2,868.	2,998.	3,128.	4,150.	4,773.	6,205.
	24"	24"	68"	<b>RCFS6833W(L/R)M</b> ( ) ( ) ( ) ( ) ( )	2,764.	3,040.	3,179.	3,317.	4,377.	5,034.	6,544.

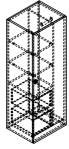

Cabinets, hinge door with shelves, Box/Box/File&wardrobe	20"	24"	68"	<b>RCFS6832X(L/R)M</b> ( ) ( ) ( ) ( ) ( )	2,758.	3,034.	3,172.	3,310.	4,294.	4,938.	6,419.
	24"	24"	68"	<b>RCFS6833X(L/R)M</b> ( ) ( ) ( ) ( ) ( )	2,921.	3,213.	3,359.	3,505.	4,542.	5,223.	6,790.

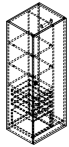

Order Code	Specification Information	Application Notes
Example: <b>RCFS6812C(L/R)M</b> ( ) ( ) ( ) ( ) ( )	<i>To order please specify pattern number including:</i>	Configurations;
<b>R</b> Reff	1. Lock	C = all shelves for 18" w cabinets
<b>C</b> Cabinet	L=Drill for lock	Y = hinge door with shelves and FF -18" w
<b>FS</b> Free Standing	N=No lock	Z = hinge door with shelves BB for 18" w
<b>68</b> Height	2. Lock finish	V = all shelves for 24" w cabinets
<b>1</b> 18" Wide	S=Silver	W = hinge door with shelves and FF and wardrobe for 24" w
<b>2</b> 20" d (nominal)	B=Black	X = hinge door with shelves and BB and wardrobe for 24" w
<b>C</b> Hinge door with shelves	3. Pull options	The images on this page are shown as a right hand cabinets.
<b>L/R</b> Left/Right hinge	Grommet	From the users perspective, if the hinges are on the right side, the cabinet is classified as "right hand" cabinet.
<b>M</b> Metal interior	4. Pull finish	
<b>L</b> Lock	Paint / Plated	
<b>S</b> Lock finish	5. Case finish	
<b>G</b> Pull option	L, V1, V2, V3	
<b>115</b> Pull finish option	6. Door finish	
<b>114</b> Case finish	L, V1, V2, V3	
<b>115</b> Door finish		

Applicable finishes are listed on page 5 and 6.

# Cabinets Progressive

49" high, wood interior  
28<sup>3</sup>/<sub>8</sub>" high planning

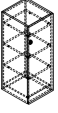
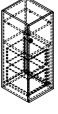
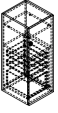
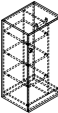
description	d	w	h	pattern no.	L/L	L/V1	L/V2	L/V3	V1/V1	V2/V2	V3/V3
Cabinets, hinge door with shelves 	20"	18"	49"	<b>RCFS4912C(L/R)W</b> ( ) ( ) ( ) ( ) ( )	\$1,871.	\$2,058.	\$2,151.	\$2,245.	\$3,119.	\$3,587.	\$4,664.
	24"	18"	49"	<b>RCFS4913C(L/R)W</b> ( ) ( ) ( ) ( ) ( )	1,914.	2,105.	2,201.	2,296.	3,217.	3,700.	4,810.
Cabinets, hinge door with shelves&File/File 	20"	18"	49"	<b>RCFS4912Y(L/R)W</b> ( ) ( ) ( ) ( ) ( )	2,684.	2,953.	3,087.	3,221.	4,026.	4,630.	6,019.
	24"	18"	49"	<b>RCFS4913Y(L/R)W</b> ( ) ( ) ( ) ( ) ( )	2,724.	2,996.	3,132.	3,268.	4,085.	4,698.	6,108.
Cabinets, hinge door with shelves&Box/File/File 	20"	18"	49"	<b>RCFS4912Z(L/R)W</b> ( ) ( ) ( ) ( ) ( )	3,112.	3,423.	3,579.	3,734.	4,357.	5,010.	6,513.
	24"	18"	49"	<b>RCFS4913Z(L/R)W</b> ( ) ( ) ( ) ( ) ( )	3,182.	3,500.	3,659.	3,818.	4,454.	5,122.	6,659.
Cabinets, hinge door with shelves&wardrobe 	20"	24"	49"	<b>RCFS4932V(L/R)W</b> ( ) ( ) ( ) ( ) ( )	2,206.	2,427.	2,537.	2,647.	3,692.	4,245.	5,519.
	24"	24"	49"	<b>RCFS4933V(L/R)W</b> ( ) ( ) ( ) ( ) ( )	2,263.	2,489.	2,602.	2,715.	3,821.	4,395.	5,668.

Order Code	Specification Information	Application Notes
Example: <b>RCFS4912C(L/R)W</b> ( ) ( ) ( ) ( ) ( )	<i>To order please specify pattern number including:</i>	Configurations;
<b>R</b> Reff	1. Lock	C = all shelves for 18" w cabinets
<b>C</b> Cabinet	L=Drill for lock	Y = hinge door with shelves and FF -18" w
<b>FS</b> Free Standing	N=No lock	Z = hinge door with shelves BB for 18" w
<b>49</b> Height	2. Lock finish	V = all shelves for 24" w cabinets
<b>1</b> 18" Wide	S=Silver	W = hinge door with shelves and FF and wardrobe for 24" w
<b>2</b> 20" d (nominal)	B=Black	X = hinge door with shelves and BB and wardrobe for 24" w
<b>C</b> Hinge door with shelves	3. Pull options	The images on this page are shown as a right hand cabinets.
<b>L/R</b> Left/Right hinge	Grommet	From the users perspective, if the hinges are on the right side, the cabinet is classified as "right hand" cabinet.
<b>W</b> Wood interior	4. Pull finish	
<b>L</b> Lock	Paint / Plated	
<b>S</b> Lock finish	5. Case finish	
<b>G</b> Pull option	L, V1, V2, V3	
<b>115</b> Pull finish option	6. Door finish	
<b>114</b> Case finish	L, V1, V2, V3	
<b>115</b> Door finish		

Applicable finishes are listed on page 5 and 6.

Cabinets Progressive  
 49" high, wood interior  
 28<sup>3</sup>/<sub>8</sub>" high planning

description	d	w	h	pattern no.	L/L	L/V1	L/V2	L/V3	V1/V1	V2/V2	V3/V3
Cabinets, hinge door with shelves, File/File&wardrobe	20"	24"	49"	<b>RCFS4932W(L/R)W</b> ( ) ( ) ( ) ( ) ( )	\$2,989.	\$3,288.	\$3,437.	\$3,587.	\$4,386.	\$5,044.	\$6,557.
	24"	24"	49"	<b>RCFS4933W(L/R)W</b> ( ) ( ) ( ) ( ) ( )	2,996.	3,295.	3,445.	3,595.	4,462.	5,131.	6,671.

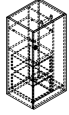

Cabinets, hinge door with shelves, Box/Box/File&wardrobe	20"	24"	49"	<b>RCFS4932X(L/R)W</b> ( ) ( ) ( ) ( ) ( )	3,375.	3,712.	3,881.	4,049.	4,765.	5,479.	7,123.
	24"	24"	49"	<b>RCFS4933X(L/R)W</b> ( ) ( ) ( ) ( ) ( )	3,421.	3,763.	3,934.	4,105.	4,878.	5,610.	7,293.

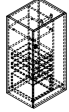

Order Code	Specification Information	Application Notes
Example: <b>RCFS4912C(L/R)W</b> ( ) ( ) ( ) ( ) ( )	<i>To order please specify pattern number including:</i>	Configurations;
<b>R</b> Reff	1. Lock L=Drill for lock N=No lock	C = all shelves for 18" w cabinets
<b>C</b> Cabinet	2. Lock finish S=Silver B=Black	Y = hinge door with shelves and FF -18" w
<b>FS</b> Free Standing	3. Pull options Grommet	Z = hinge door with shelves BB for 18" w
<b>49</b> Height	4. Pull finish Paint / Plated	V = all shelves for 24" w cabinets
<b>1</b> 18" Wide	5. Case finish L, V1, V2, V3	W = hinge door with shelves and FF and wardrobe for 24" w
<b>2</b> 20" d (nominal)	6. Door finish L, V1, V2, V3	X = hinge door with shelves and BB and wardrobe for 24" w
<b>C</b> Hinge door with shelves		The images on this page are shown as a right hand cabinets.
<b>L/R</b> Left/Right hinge		From the users perspective, if the hinges are on the right side, the cabinet is classified as "right hand" cabinet.
<b>W</b> Wood interior		
<b>L</b> Lock		
<b>S</b> Lock finish		
<b>G</b> Pull option		
<b>115</b> Pull finish option		
<b>114</b> Case finish		
<b>115</b> Door finish		

Applicable finishes are listed on page 5 and 6.

Cabinets Progressive  
 64" high, wood interior  
 28<sup>3/8</sup>" high planning

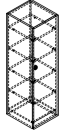
description	d	w	h	pattern no.	L/L	LV1	L/V2	L/V3	V1/V1	V2/V2	V3/V3
Cabinet, hinge door with shelves 	20"	18"	64"	<b>RCFS6412C(L/R)W</b> (X)(X)(X)(X)(X)	\$2,064.	\$2,270.	\$2,374.	\$2,477.	\$3,529.	\$4,058.	\$5,276.
	24"	18"	64"	<b>RCFS6413C(L/R)W</b> (X)(X)(X)(X)(X)	2,117.	2,329.	2,435.	2,541.	3,666.	4,216.	5,481.

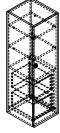
Cabinets, hinge door with shelves&File/File 	20"	18"	64"	<b>RCFS6412Y(L/R)W</b> (X)(X)(X)(X)(X)	2,963.	3,259.	3,407.	3,555.	4,444.	5,111.	6,644.
	24"	18"	64"	<b>RCFS6413Y(L/R)W</b> (X)(X)(X)(X)(X)	3,071.	3,378.	3,532.	3,685.	4,607.	5,298.	6,887.

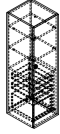
Cabinets, hinge door with shelves&Box/File/File 	20"	18"	64"	<b>RCFS6412Z(L/R)W</b> (X)(X)(X)(X)(X)	3,411.	3,752.	3,923.	4,093.	4,775.	5,492.	7,139.
	24"	18"	64"	<b>RCFS6413Z(L/R)W</b> (X)(X)(X)(X)(X)	3,554.	3,909.	4,087.	4,265.	4,976.	5,722.	7,439.

Order Code	Specification Information	Application Notes
Example: <b>RCFS6412C(L/R)W</b> <b>(X)(X)(X)(X)(X)</b>	<i>To order please specify pattern number including:</i>	Configurations;
<b>R</b> Reff	1. Lock	C = all shelves for 18" w cabinets
<b>C</b> Cabinet	L=Drill for lock	Y = hinge door with shelves and FF -18" w
<b>FS</b> Free Standing	N=No lock	Z = hinge door with shelves BB for 18" w
<b>64</b> Height	2. Lock finish	V = all shelves for 24" w cabinets
<b>1</b> 18" Wide	S=Silver	W = hinge door with shelves and FF and wardrobe for 24" w
<b>2</b> 20" d (nominal)	B=Black	X = hinge door with shelves and BB and wardrobe for 24" w
<b>C</b> Hinge door with shelves	3. Pull options	The images on this page are shown as a right hand cabinets.
<b>L/R</b> Left/Right hinge	Grommet	From the users perspective, if the hinges are on the right side, the cabinet is classified as "right hand" cabinet.
<b>W</b> Wood interior	4. Pull finish	
<b>L</b> Lock	Paint / Plated	
<b>S</b> Lock finish	5. Case finish	
<b>G</b> Pull option	L, V1, V2, V3	
<b>115</b> Pull finish option	6. Door finish	
<b>114</b> Case finish	L, V1, V2, V3	
<b>115</b> Door finish		

Applicable finishes are listed on page 5 and 6.

Cabinets Progressive  
 64" high, wood interior  
 28<sup>3/8</sup>" high planning

description	d	w	h	pattern no.	L/L	LV1	L/V2	L/V3	V1/V1	V2/V2	V3/V3
Cabinets, hinge door with shelves&wardrobe	20"	24"	64"	<b>RCFS6432V(L/R)W</b> ( ) ( ) ( ) ( ) ( )	\$2,415.	\$2,656.	\$2,777.	\$2,898.	\$4,162.	\$4,786.	\$6,222.
	24"	24"	64"	<b>RCFS6433V(L/R)W</b> ( ) ( ) ( ) ( ) ( )	2,484.	2,733.	2,857.	2,981.	4,345.	4,996.	6,495.

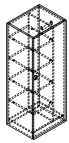

Cabinets, hinge door with shelves, File/File&wardrobe	20"	24"	64"	<b>RCFS6432W(L/R)W</b> ( ) ( ) ( ) ( ) ( )	3,198.	3,517.	3,677.	3,837.	4,856.	5,584.	7,260.
	24"	24"	64"	<b>RCFS6433W(L/R)W</b> ( ) ( ) ( ) ( ) ( )	3,286.	3,615.	3,779.	3,943.	5,050.	5,807.	7,549.

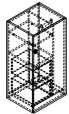

Cabinets, hinge door with shelves, Box/Box/File&wardrobe	20"	24"	64"	<b>RCFS6432X(L/R)W</b> ( ) ( ) ( ) ( ) ( )	3,583.	3,942.	4,121.	4,300.	5,235.	6,020.	7,826.
	24"	24"	64"	<b>RCFS6433X(L/R)W</b> ( ) ( ) ( ) ( ) ( )	3,712.	4,083.	4,268.	4,454.	5,466.	6,286.	8,171.

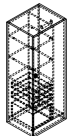

Order Code	Specification Information	Application Notes
Example: <b>RCFS6412C(L/R)W</b> ( ) ( ) ( ) ( ) ( )	<i>To order please specify pattern number including:</i>	Configurations;
<b>R</b> Reff	1. Lock	C = all shelves for 18" w cabinets
<b>C</b> Cabinet	L=Drill for lock	Y = hinge door with shelves and FF -18" w
<b>FS</b> Free Standing	N=No lock	Z = hinge door with shelves BB for 18" w
<b>64</b> Height	2. Lock finish	V = all shelves for 24" w cabinets
<b>1</b> 18" Wide	S=Silver	W = hinge door with shelves and FF and wardrobe for 24" w
<b>2</b> 20" d (nominal)	B=Black	X = hinge door with shelves and BB and wardrobe for 24" w
<b>C</b> Hinge door with shelves	3. Pull options	The images on this page are shown as a right hand cabinets.
<b>L/R</b> Left/Right hinge	Grommet	From the users perspective, if the hinges are on the right side, the cabinet is classified as "right hand" cabinet.
<b>W</b> Wood interior	4. Pull finish	
<b>L</b> Lock	Paint / Plated	
<b>S</b> Lock finish	5. Case finish	
<b>G</b> Pull option	L, V1, V2, V3	
<b>115</b> Pull finish option	6. Door finish	
<b>114</b> Case finish	L, V1, V2, V3	
<b>115</b> Door finish		

Applicable finishes are listed on page 5 and 6.

Cabinets Progressive  
68" high wood interior  
28<sup>3/8</sup>" high planning

description	d	w	h	pattern no.	L/L	L/V1	L/V2	L/V3	V1/V1	V2/V2	V3/V3
Cabinet, hinge door with shelves	20"	18"	68"	<b>RCFS6812C(L/R)W(X)(X)(X)(X)</b>	\$2,086.	\$2,294.	\$2,399.	\$2,503.	\$3,597.	\$4,136.	\$5,377.
	24"	18"	68"	<b>RCFS6813C(L/R)W(X)(X)(X)(X)</b>	2,141.	2,355.	2,462.	2,569.	3,727.	4,286.	5,572.

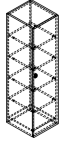

Cabinets, hinge door with shelves&File/File	20"	18"	68"	<b>RCFS6812Y(L/R)W(X)(X)(X)(X)</b>	3,014.	3,315.	3,466.	3,617.	4,521.	5,199.	6,759.
	24"	18"	68"	<b>RCFS6813Y(L/R)W(X)(X)(X)(X)</b>	3,118.	3,430.	3,586.	3,742.	4,677.	5,379.	6,992.

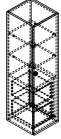

Cabinets, hinge door with shelves&Box/File/File	20"	18"	68"	<b>RCFS6812Z(L/R)W(X)(X)(X)(X)</b>	3,466.	3,813.	3,986.	4,159.	4,852.	5,580.	7,254.
	24"	18"	68"	<b>RCFS6813Z(L/R)W(X)(X)(X)(X)</b>	3,604.	3,965.	4,145.	4,325.	5,046.	5,803.	7,544.

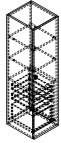

Order Code	Specification Information	Application Notes
Example: <b>RCFS6812C(L/R)W(X)(X)(X)(X)</b>	<i>To order please specify pattern number including:</i>	Configurations;
<b>R</b> Reff	1. Lock	C = all shelves for 18" w cabinets
<b>C</b> Cabinet	L=Drill for lock N=No lock	Y = hinge door with shelves and FF -18" w
<b>FS</b> Free Standing	2. Lock finish	Z = hinge door with shelves BB for 18" w
<b>68</b> Height	S=Silver B=Black	V = all shelves for 24" w cabinets
<b>1</b> 18" Wide	3. Pull options Grommet	W = hinge door with shelves and FF and wardrobe for 24" w
<b>2</b> 20" d (nominal)	4. Pull finish Paint / Plated	X = hinge door with shelves and BB and wardrobe for 24" w
<b>C</b> Hinge door with shelves	5. Case finish L, V1, V2, V3	The images on this page are shown as a right hand cabinets.
<b>L/R</b> Left/Right hinge	6. Door finish L, V1, V2, V3	From the users perspective, if the hinges are on the right side, the cabinet is classified as "right hand" cabinet.
<b>W</b> Wood interior		
<b>L</b> Lock		
<b>S</b> Lock finish		
<b>G</b> Pull option		
<b>115</b> Pull finish option		
<b>114</b> Case finish		
<b>115</b> Door finish		

Applicable finishes are listed on page 5 and 6.

Cabinets Progressive  
 68" high wood interior  
 28<sup>3/8</sup>" high planning

description	d	w	h	pattern no.	L/L	L/V1	L/V2	L/V3	V1/V1	V2/V2	V3/V3
Cabinets, hinge door with shelves&wardrobe	20"	24"	68"	RCFS6832V(L/R)W()()()()()	\$2,443.	\$2,687.	\$2,809.	\$2,931.	\$4,249.	\$4,887.	\$6,353.
	24"	24"	68"	RCFS6833V(L/R)W()()()()()	2,514.	2,766.	2,892.	3,017.	4,429.	5,094.	6,622.

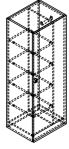

Cabinets, hinge door with shelves, File/File&wardrobe	20"	24"	68"	RCFS6832W(L/R)W()()()()()	3,236.	3,559.	3,721.	3,883.	4,953.	5,696.	7,405.
	24"	24"	68"	RCFS6833W(L/R)W()()()()()	3,326.	3,659.	3,825.	3,991.	5,143.	5,915.	7,690.

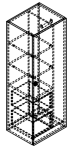

Cabinets, hinge door with shelves, Box/Box/File&wardrobe	20"	24"	68"	RCFS6832X(L/R)W()()()()()	3,621.	3,983.	4,164.	4,345.	5,332.	6,131.	7,971.
	24"	24"	68"	RCFS6833X(L/R)W()()()()()	3,752.	4,127.	4,314.	4,502.	5,560.	6,394.	8,312.

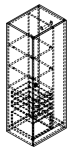

Order Code	Specification Information	Application Notes
Example: <b>RCFS6812C(L/R)W</b> <b>()()()()()</b>	<i>To order please specify pattern number including:</i>	Configurations;
<b>R</b> Reff	1. Lock	C = all shelves for 18" w cabinets
<b>C</b> Cabinet	L=Drill for lock	Y = hinge door with shelves and FF -18" w
<b>FS</b> Free Standing	N=No lock	Z = hinge door with shelves BB for 18" w
<b>68</b> Height	2. Lock finish	V = all shelves for 24" w cabinets
<b>1</b> 18" Wide	S=Silver	W = hinge door with shelves and FF and wardrobe for 24" w
<b>2</b> 20" d (nominal)	B=Black	X = hinge door with shelves and BB and wardrobe for 24" w
<b>C</b> Hinge door with shelves	3. Pull options	
<b>L/R</b> Left/Right hinge	Grommet	
<b>W</b> Wood interior	4. Pull finish	
<b>L</b> Lock	Paint / Plated	
<b>S</b> Lock finish	5. Case finish	
<b>G</b> Pull option	L, V1, V2, V3	
<b>115</b> Pull finish option	6. Door finish	
<b>114</b> Case finish	L, V1, V2, V3	
<b>115</b> Door finish		

These products are Glue and Dowel Construction  
 Grommet pulls only.  
 Shelves and files front will default to the case finish.  
 68" h Cabinets are for the private offices application to align with a single high overhead, and are compatible with panel height.  
 No wardrobe option in the 18" w cabinets.

The images on this page are shown as a right hand cabinets.  
 From the users perspective, if the hinges are on the right side, the cabinet is classified as "right hand" cabinet.



# Desktop Towers

## 28<sup>3</sup>/<sub>8</sub>" high planning

### Single Wide, 42" and 56" High Bookcase

description	w	d	h	pattern no.	L	V1	V2	V3
42" h Desk top tower, single width bookcase open wood shelves	16"	15"	42"	<b>RDTSBWT142</b> ( ) ( )	\$1,155.	\$1,981.	\$2,278.	\$2,961.
	19"	15"	42"	<b>RDTSBWG142</b> ( ) ( )	1,185.	2,031.	2,335.	3,036.



56" h Desk top tower, single width bookcase open wood shelves	16"	15"	56"	<b>RDTSBWT156</b> ( ) ( )	1,336.	2,291.	2,635.	3,425.
	19"	15"	56"	<b>RDTSBWG156</b> ( ) ( )	1,370.	2,348.	2,700.	3,510.

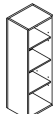

Order Code	Specification Information	Application Notes
Example: <b>RDTSBWT142</b> ( ) ( )	<i>To order please specify pattern number including:</i>	Heights to work with 28 <sup>3</sup> / <sub>8</sub> " desk height planning and 1 1/2" worksurface.
<b>R</b> Reff	Left or right hand as applicable and embedded in the pattern number.	
<b>DT</b> Reff Desktop Tower		
<b>S</b> Single width		
<b>B</b> Bookcase	1. Case finish type	Shelves to match case finish.
<b>W</b> Wood Shelves	L = Laminate	Shelves on single height available with 2 adjustable shelves.
<b>T</b> Letter width 16" nominal	1 = V1	
<b>1</b> Letter depth 15" nominal	2 = V2	
<b>42</b> 42" high nominal	3 = V3	Shelves on double high available with one fixed middle shelf, one upper and one lower adjustable shelf.
<b>V2</b> Case finish type	2. Case finish	
<b>V316</b> Case finish		
<b>AU</b> Door frame finish		
<b>GL11</b> Door glass finish		

42" h desk top towers for use with single tier overhead bridges and floorstanding cabinet.

56" h desk top tower for use with double tier overhead bridges and floor standing cabinet.

Hinge doors feature no pulls only touch latch.

These products are Glue and Dowel Construction

# Desktop Towers

## 28<sup>3</sup>/<sub>8</sub>" high planning

### Single Wide, 42" and 56" High

#### Wood Hinge Door

description	w	d	h	pattern no.	L/L	L/V1	L/V2	L/V3	V1/V1	V2/V2	V3/V3
42" h Desk top tower, single width	16"	15"	42"	<b>RDTSHWT142(L/R)</b> ( ) ( ) ( ) ( ) ( )	\$1,503.	\$1,653.	\$1,728.	\$1,879.	\$2,576.	\$2,963.	\$3,852.
wood shelves behind wood hinge door	19"	15"	42"	<b>RDTSHWG142(L/R)</b> ( ) ( ) ( ) ( ) ( )	1,545.	1,700.	1,777.	1,932.	2,649.	3,047.	3,960.



56" h Desk top tower, single width	16"	15"	56"	<b>RDTSHWT156(L/R)</b> ( ) ( ) ( ) ( ) ( )	1,713.	1,884.	2,073.	2,280.	2,937.	3,377.	4,391.
wood shelves behind wood hinge door	19"	15"	56"	<b>RDTSHWG156(L/R)</b> ( ) ( ) ( ) ( ) ( )	1,761.	1,937.	2,130.	2,343.	3,018.	3,471.	4,512.



Order Code	Specification Information	Application Notes
Example: <b>RDTSHWT142 ( ) ( )</b>	<i>To order please specify pattern number including:</i>	Heights to work with 28 <sup>3</sup> / <sub>8</sub> " desk height planning and 1 1/2" worksurface.
<b>R</b> Reff	Left or right hand as applicable and embedded in the pattern number.	42" h desk top towers for use with single tier overhead bridges and floorstanding cabinet.
<b>DT</b> Reff Desktop Tower		
<b>S</b> Single width	1. Case finish type	56" h desk top tower for use with double tier overhead bridges and floor standing cabinet.
<b>H</b> Hinge Door	L = Laminate	
<b>W</b> Wood Shelves	1 = V1	
<b>T</b> Letter width 16" nominal	2 = V2	
<b>1</b> Letter depth 15" nominal	3 = V3	
<b>42</b> 42" high nominal	2. Front finish type	
<b>2</b> Finish type	L = Laminate	Shelves on single wide available with 2 adjustable shelves.
<b>T</b> Pull option	1 = V1	
<b>L</b> Lock option	2 = V2	
<b>B</b> Lock finish	3 = V3	
<b>V316</b> Case finish	3. Pull option=Painted and plated	Shelves on double high available with one fixed middle shelf, one upper and one lower adjustable shelf.
<b>V316</b> Front finish	B=Blank (no drilling)	
<b>111</b> Pull finish	F=Bar pull	
	H=Outline pull	
	N=No pull, touch latch	
	R=Cylinder pull	
	T=Tab pull	
	4. Lock option L or N	
	5. Lock finish	
	B=Black	
	S=Matte Silver	
	6. Case finish= *V316	
	7. Front finish=V316	
	8. Pull finish=111	
		These products are Glue and Dowel Construction

Desktop Towers  
 28<sup>3</sup>/<sub>8</sub>" high planning  
 Single Wide, 42" and 56" High  
 Glass hinge door

description	w	d	h	pattern no.	L	V1	V2	V3
42" h Desk top tower, single width bookcase open wood shelves	16"	15"	42"	<b>RDTSJWT142(L/R)( ) ( ) ( )</b>	\$2,147.	\$2,791.	\$3,210.	\$4,173.
	18"	15"	42"	<b>RDTSJWT142(L/R)( ) ( ) ( )</b>	2,237.	2,908.	3,344.	4,384.



56" h Desk top tower, single width bookcase open wood shelves	16"	15"	56"	<b>RDTSJWT156(L/R)( ) ( ) ( )</b>	2,485.	3,230.	3,715.	4,830.
	18"	15"	56"	<b>RDTSJWT156(L/R)( ) ( ) ( )</b>	2,595.	3,373.	3,879.	5,043.



Desktop towers

Order Code	Specification Information	Application Notes
Example: <b>RDTSJWT142 ( ) ( ) ( )</b>	<i>To order please specify pattern number including:</i>	Heights to work with 28 <sup>3</sup> / <sub>8</sub> " desk height planning and 1 1/2" worksurface.
<b>R</b> Reff	Left or right hand as applicable and embedded in the pattern number.	42" h desk top towers for use with single tier overhead bridges and floorstanding cabinet.
<b>DT</b> Reff Desktop Tower		
<b>S</b> Single width		
<b>G</b> Hinge glass door	1. Case finish type	Shelves to match case finish.
<b>W</b> Wood Shelves	L = Laminate	Shelves on single height available with 2 adjustable shelves.
<b>T</b> Letter width 16" nominal	1 = V1	
<b>1</b> Letter depth 15" nominal	2 = V2	Shelves on double high available with one fixed middle shelf, one upper and one lower adjustable shelf.
<b>42</b> 42" high nominal	3 = V3	
<b>L</b> Left / Right hand	2. Case finish V316	
<b>2</b> Case finish type	3. Door frame ypte=Anodized / Painted	
<b>V316</b> Case finish	4. Door glass finish = G111/18/15.	
<b>AU</b> Door frame finish		Glass hinge doors available only with touch latch.
<b>GL11</b> Door glass finish		These products are Glue and Dowel Construction

# Desktop Towers

## *28<sup>3</sup>/<sub>8</sub>" high planning*

### *Double Wide, 42" and 56" High Bookcase*

description	w	d	h	pattern no.	L	V1	V2	V3
42" h Desk top tower, double width bookcase / open shelves	30"	15"	42"	<b>RDTDBW3142()</b> ( )	\$1,757.	\$2,811.	\$3,232.	\$4,202.
	36"	15"	42"	<b>RDTDBW6142()</b> ( )	1,807.	2,892.	3,325.	4,323.

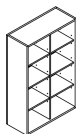

56" h Desk top tower, double width bookcase / open shelves	30"	15"	56"	<b>RDTDBW3156()</b> ( )	2,097.	3,354.	3,858.	5,015.
	36"	15"	56"	<b>RDTDBW6156()</b> ( )	2,154.	3,446.	3,963.	5,152.

Order Code	Specification Information	Application Notes
Example: <b>RDTDBW3142()</b> ( )	<i>To order please specify pattern number including:</i>	Heights to work with 28 <sup>3</sup> / <sub>8</sub> " desk height planning and 1 <sup>1</sup> / <sub>2</sub> " worksurface.
<b>R</b> Reff	Left or right hand as applicable and embedded in the pattern number.	Shelves to match case finish.
<b>DT</b> Reff Desktop Tower		Shelves with door option on single height available with 2 adjustable shelves.
<b>D</b> Double width	1. Case finish type	Shelves on double high available with one fixed middle shelf, one upper and one lower adjustable shelf.
<b>B</b> Bookcase	L = Laminate	
<b>W</b> Wood Shelves	1 = V1	
<b>3</b> 30" wide	2 = V2	
<b>1</b> Letter depth 15" nominal	3 = V3	
<b>42</b> 42" high nominal	2. Case finish V316	
<b>2</b> Case finish type	3. Pull option Plated / Painted	
<b>V316</b> Case finish	4. Lock option L, N	
	5. Lock finish	
	S=Matte Silver	
	B=Black	
	6. Case finish V316	
	7. Front finish V313	
	8. Pull finish 111	

42" h desk top towers for use with single tier overhead bridges and floorstanding cabinet.

56" h desk top tower for use with double tier overhead bridges and floor standing cabinet.

Hinge doors feature no pulls only touch latch.

These products are Glue and Dowel Construction

**Desktop Towers**  
*28<sup>3/8</sup>" high planning*  
*Double Wide, 42" and 56" High*  
*Wood shelves behind doors*

description	w	d	h	pattern no.	L/L	L/V1	L/V2	L/V3	V1/V1	V2/V2	V3/V3
42" h Desk top tower, double width	30"	15"	42"	<b>RDTDHW3142</b> ( ) ( ) ( ) ( ) ( )	\$2,063.	\$2,373.	\$2,476.	\$2,683.	\$3,301.	\$3,796.	\$4,935.
wood shelves behind wood hinge door	36"	15"	42"	<b>RDTDHW6142</b> ( ) ( ) ( ) ( ) ( )	2,142.	2,463.	2,570.	2,785.	3,427.	3,941.	5,124.

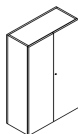

56" h Desk top tower, double width	30"	15"	56"	<b>RDTDHW3156</b> ( ) ( ) ( ) ( ) ( )	2,386.	2,625.	2,888.	3,176.	3,818.	4,391.	5,708.
wood shelves behind wood hinge door	36"	15"	56"	<b>RDTDHW6156</b> ( ) ( ) ( ) ( ) ( )	2,496.	2,745.	3,020.	3,322.	3,993.	4,592.	5,970.

Order Code	Specification Information	Application Notes
Example: <b>RDTDHW3142</b> ( ) ( )	<i>To order please specify pattern number including:</i>	Heights to work with 28 <sup>3/8</sup> " desk height planning and 1 <sup>1/2</sup> " worksurface.
<b>RDT</b> Reff Desktop Tower	Left or right hand as applicable and embedded in the pattern number.	42" h desk top towers for use with single tier overhead bridges and floorstanding cabinet.
<b>D</b> Double width		
<b>H</b> Hinge door wood		
<b>W</b> Wood Shelves	1. Case finish type	56" h desk top tower for use with double tier overhead bridges and floor standing cabinet.
<b>3</b> 30" wide	L = Laminate	
<b>1</b> Letter depth 15" nominal	1 = V1	
<b>42</b> 42" high nominal	2 = V2	
<b>L</b> Left/ Right hand option	3 = V3	
<b>V2</b> Case finish type	2. Case finish V316	
<b>V2</b> Font finish type	3. Pull option Plated / Painted	
<b>F</b> Pull option	4. Lock option L, N	
<b>L</b> Lock option doors	5. Lock finish	Shelves to match case finish.
<b>B</b> Lock finish	S=Matte Silver	Shelves with door option on single height available with 2 adjustable shelves.
<b>V316</b> Case finish	B=Black	
<b>V316</b> Front finish	6. Case finish V316	Shelves on double high available with one fixed middle shelf, one upper and one lower adjustable shelf.
<b>111</b> Pull finish	7. Front finish V313	
	8. Pull finish 111	

Desktop towers

Desktop Towers  
 28<sup>3/8</sup>" high planning  
 Double Wide, 42" and 56" High  
 Asymmetrical, with Glass door

description	w	d	h	pattern no.	L	V1	V2	V3
Desk top tower, double width -Asymmetrical	30"	15"	42"	<b>RDTAGW3142(L/R)( ) ( ) ( )</b>	\$2,865.	\$3,724.	\$4,283.	\$5,568.
Split glass hinged door / open shelves all wood	30"	15"	56"	<b>RDTAGW3156(L/R)( ) ( ) ( )</b>	3,399.	4,419.	5,082.	6,607.
	36"	15"	42"	<b>RDTAGW6142(L/R)( ) ( ) ( )</b>	3,052.	3,967.	4,562.	5,931.
	36"	15"	56"	<b>RDTAGW6156(L/R)( ) ( ) ( )</b>	3,641.	4,733.	5,443.	7,076.

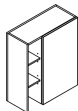

Desk top tower, double width -Asymmetrical	30"	15"	42"	<b>RDTAGG3142(L/R)( ) ( ) ( )</b>	2,747.	3,571.	4,107.	5,339.
Split glass hinged door / open shelves all glass	30"	15"	56"	<b>RDTAGG3156(L/R)( ) ( ) ( )</b>	3,223.	4,190.	4,819.	6,264.
	36"	15"	42"	<b>RDTAGG6142(L/R)( ) ( ) ( )</b>	2,934.	3,814.	4,387.	5,702.
	36"	15"	56"	<b>RDTAGG6156(L/R)( ) ( ) ( )</b>	3,465.	4,504.	5,180.	6,734.

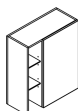

Desk top tower, double width	30"	15"	42"	<b>RDTDGW3142( ) ( ) ( ) ( ) ( )</b>	3,604.	4,325.	4,974.	6,466.
wood shelves behind glass hinge door	30"	15"	56"	<b>RDTDGW3156( ) ( ) ( ) ( ) ( )</b>	4,157.	4,988.	5,736.	7,457.
	36"	15"	42"	<b>RDTDGW6142( ) ( ) ( ) ( ) ( )</b>	3,760.	4,512.	5,189.	6,746.
	36"	15"	56"	<b>RDTDGW6156( ) ( ) ( ) ( ) ( )</b>	4,427.	5,312.	6,109.	7,942.

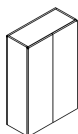

Order Code	Specification Information	Application Notes
Example: <b>RDTAGW3142</b>	<i>To order please specify pattern number including:</i>	Heights to work with 28 <sup>3/8</sup> " desk height planning and 1 <sup>1/2</sup> " worksurface.
<b>RDT</b> Reff Desktop Tower	Left or right hand as applicable and embedded in the pattern number.	42"h desk top towers for use with single tier overhead bridges and floorstanding cabinet.
<b>A</b> Asymmetrical split		
<b>G</b> Hinge door glass	1. Case finish type	56"h desk top tower for use with double tier overhead bridges and floor standing cabinet.
<b>W</b> Wood Shelves	L = Laminate	
<b>3</b> 30" wide nominal	1 = V1	
<b>1</b> Letter depth 15" nominal	2 = V2	
<b>42</b> 42" high nominal	3 = V3	
<b>(L)</b> Left / Right hand option	2. Case finish V316	Hinge doors feature <u>no</u> pulls only touch latch.
<b>V2</b> Case finish type	3. Door finish type, Plated / Painted	Desk top tower backs.
<b>V316</b> Case finish	4. Door glass finish = GL11/18/15.	These products are Glue and Dowel Construction
<b>AU</b> Door frame finish	For desk top with open shelves, all glass	
<b>GL11</b> Door glass finish	5. Shelf, glass finish:	
	GL35 - Grey	
	GL85 - Star clear	

Desktop Towers  
 28<sup>3/8</sup>" high planning  
 Double Wide, 42" and 56" High  
 Asymmetrical with mix casing

Reff Profiles

description	w	d	h	pattern no.	L/L	L/V1	L/V2	L/V3	V1/V1	V2/V2	V3/V3
Desk top tower, double width -Asymmetrical Split hinged door / open shelves all wood	30"	15"	42"	<b>RDTAHW3142(L/R)</b> ( ) ( ) ( ) ( ) ( )	\$2,188.	\$2,406.	\$2,516.	\$2,625.	\$3,347.	\$3,849.	\$5,004.
	30"	15"	56"	<b>RDTAHW3156(L/R)</b> ( ) ( ) ( ) ( ) ( )	2,554.	2,809.	2,937.	3,065.	3,907.	4,493.	5,842.
	36"	15"	42"	<b>RDTAHW6142(L/R)</b> ( ) ( ) ( ) ( ) ( )	2,273.	2,500.	2,613.	2,727.	3,477.	3,998.	5,198.
	36"	15"	56"	<b>RDTAHW6156(L/R)</b> ( ) ( ) ( ) ( ) ( )	2,668.	2,935.	3,069.	3,202.	4,083.	4,695.	6,104.

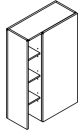

Desk top tower, double width -Asymmetrical Split hinged door / open shelves all glass	30"	15"	42"	<b>RDTAHG3142(L/R)</b> ( ) ( ) ( ) ( ) ( )	2,368.	2,586.	2,696.	2,805.	3,527.	4,029.	5,184.
	30"	15"	56"	<b>RDTAHG3156(L/R)</b> ( ) ( ) ( ) ( ) ( )	2,824.	3,079.	3,207.	3,335.	4,177.	4,763.	6,112.
	36"	15"	42"	<b>RDTAHG6142(L/R)</b> ( ) ( ) ( ) ( ) ( )	2,453.	2,680.	2,793.	2,907.	3,657.	4,178.	5,378.
	36"	15"	56"	<b>RDTAHG6156(L/R)</b> ( ) ( ) ( ) ( ) ( )	2,938.	3,205.	3,339.	3,472.	4,353.	4,965.	6,374.

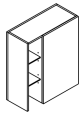

Order Code	Specification Information	Application Notes
Example: <b>RDTAHW3142(L/R)</b> ( ) ( ) ( ) ( ) ( )	<i>To order please specify pattern number including:</i> Left or right hand as applicable and embedded in the pattern number.	Heights to work with 28 <sup>3/8</sup> " desk height planning and 1 <sup>1/2</sup> " worksurface.
<b>RDT</b> Reff Desktop Tower		Shelves to match case finish.
<b>A</b> Asymmetrical split	1. Case finish type: L, V1, V2, V3	42" h desk top towers for use with single tier overhead bridges and floorstanding cabinet.
<b>H</b> Hinge door wood	2. Front finish type: L, V1, V2, V3	56" h desk top tower for use with double tier overhead bridges and floor standing cabinet.
<b>W</b> Wood Shelves	3. Pull option: B=No pull F=Bar pull H=Outline pull N=No pull, touch latch R=Cylinder pull T=Tab pull	Hinge doors feature <u>no</u> pulls only touch latch.
<b>3</b> 30" wide nominal	4. Lock option: L, N	These products are Glue and Dowel Construction
<b>1</b> Letter depth 15" nominal	5. Lock finish: B=Black S=Matte Silver	
<b>42</b> 42" high nominal	6. Case finish: V316	
<b>L</b> Left / Right hand option	7. Front finish: V316	
<b>V2</b> Case finish type	8. Pull finish: Painted or Plated	
<b>V2</b> Front finish type		
<b>F</b> Pull option		
<b>L</b> Lock option		
<b>B</b> Lock finish		
<b>V316</b> Case finish		
<b>V316</b> Front finish		
<b>111</b> Pull finish		

# Overhead, 26 1/2" planning

## Wall hung, Single high

Reff Profiles

description	h	w	d	locks req'd	doors	pattern no.	L	V1	V2	V3
Wall-hung overhead cabinet (open) with back	19"	30"	15"			<b>ROMO30S0(-)(-)(-)</b>	\$1,730.	\$1,791.	\$2,058.	\$2,777.
	19"	36"	15"			<b>ROMO36S0(-)(-)(-)</b>	1,775.	1,837.	2,111.	2,849.
	19"	42"	15"			<b>ROMO42S0(-)(-)(-)</b>	1,820.	1,884.	2,165.	2,923.
	19"	48"	15"			<b>ROMO48S0(-)(-)(-)</b>	1,871.	1,930.	2,225.	3,003.
	19"	60"	15"			<b>ROMO60S0(-)(-)(-)</b>	2,065.	2,133.	2,455.	3,314.
	19"	72"	15"			<b>ROMO72S0(-)(-)(-)</b>	2,180.	2,258.	2,595.	3,502.

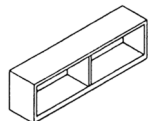

Wall-hung overhead cabinet (hinged door) with back	19"	30"	15"	1	2	<b>ROMH30S0(-)(-)(-)</b>	2,516.	2,600.	2,986.	4,033.
	19"	36"	15"	1	2	<b>ROMH36S0(-)(-)(-)</b>	2,678.	2,771.	3,185.	4,300.
	19"	60"	15"	2	4	<b>ROMH60S0(-)(-)(-)</b>	3,008.	3,108.	3,576.	4,828.
	19"	72"	15"	2	4	<b>ROMH72S0(-)(-)(-)</b>	3,183.	3,290.	3,785.	5,109.

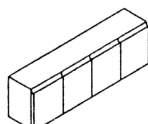

Wall-hung overhead cabinet flip door) with back	19"	30"	15"	1	1	<b>ROMF30S0(-)(-)(-)</b>	1,843.	1,906.	2,190.	2,958.
	19"	36"	15"	1	1	<b>ROMF36S0(-)(-)(-)</b>	1,962.	2,029.	2,334.	3,151.
	19"	42"	15"	1	1	<b>ROMF42S0(-)(-)(-)</b>	2,077.	2,152.	2,474.	3,340.
	19"	48"	15"	1	1	<b>ROMF48S0(-)(-)(-)</b>	2,199.	2,273.	2,614.	3,529.
	19"	60"	15"	2	2	<b>ROMF60S0(-)(-)(-)</b>	2,424.	2,508.	2,883.	3,893.
	19"	72"	15"	2	2	<b>ROMF72S0(-)(-)(-)</b>	2,565.	2,652.	3,050.	4,118.

Order Code	
Example: <b>ROMO30S0</b>	
<b>R</b>	Reff
<b>O</b>	Overhead
<b>M</b>	Wall hung
<b>O</b>	Open
<b>30</b>	30" wide
<b>S</b>	Standard height, 19"h
<b>0</b>	15" deep

**Specification Information**

To order please specify pattern number including:

1. Configuration option (*embedded in pattern no.*)  
H = Hinged door  
O = Open  
F = Flip door
2. Storage option (*embedded in pattern no.*)  
S0 = 19"h x 14" d open/15" d hinged door
3. Finish type
4. Pull option *applicable hinged doors only*
5. Lock option
6. Finish, case
7. Finish, pull when applicable
8. Keying instructions

**\*After specifying product code, provide keying instructions.**

**Dimensions are nominal.**

Product not available where prices do not appear.

3. *Finish type options:*  
L = Laminate  
1 = V1 techwood  
2 = V2 conventional veneer  
3 = V3 exotic veneer

4. *Pull Options:*  
D = Metal D-pull for hinged door only  
J = Routed pull  
C = Nickel finish C-pull for hinged door only (nickel finish only)  
S = Stainless steel finish S-pull for hinged door only (stainless steel finish only)

5. *Lock options:*  
L = Lock hole drilled  
N = No lockdrilling

8. Refer to page 523 for keying instructions.

Applicable finishes are listed on page 5 and 6.

Sliding rails order separately on page 0.

### Application Notes

Panel-hung cabinets are shipped knocked-down. Wall-hung overhead cabinets are shipped assembled.

Open cabinets require no locks.

Tasklights are not included.

D-Pulls are not available for flip door units.

Hardware included for overhead cabinets.

**The manufacturer does not take responsibility for the installation or the security of cabinets to the wall.**

**\*Keying instructions must accompany all cabinet orders.**

Panel-hung overheads come with no backs.

Random keys are factory installed.

Order overheads with a KnollKey order form.



# Overhead, 26 1/2" planning

## Panel hung, Single high

Reff Profiles

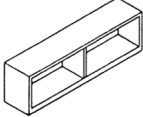
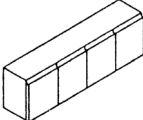
description	h	w	d	locks req'd	doors	pattern no.	L	V1	V2	V3
Panel-hung overhead cabinet (open) no back 	19"	30"	14"			<b>ROPO30S0(-)(-)(-)</b>	\$1,241.	\$1,281.	\$1,473.	\$1,989.
	19"	36"	14"			<b>ROPO36S0(-)(-)(-)</b>	1,518.	1,569.	1,805.	2,437.
	19"	42"	14"			<b>ROPO42S0(-)(-)(-)</b>	1,668.	1,725.	1,985.	2,680.
	19"	48"	14"			<b>ROPO48S0(-)(-)(-)</b>	1,730.	1,786.	2,056.	2,775.
	19"	60"	14"			<b>ROPO60S0(-)(-)(-)</b>	1,767.	1,828.	2,105.	2,842.
	19"	72"	14"			<b>ROPO72S0(-)(-)(-)</b>	2,167.	2,238.	2,575.	3,475.
	19"	90"	14"			<b>ROPO90S0(-)(-)(-)</b>	2,384.	2,463.	2,832.	3,824.
	19"	96"	14"			<b>ROPO96S0(-)(-)(-)</b>	2,471.	2,554.	2,936.	3,964.
	23"	60"	14"			<b>ROPO60T0(-)(-)(-)</b>	1,888.	1,954.	2,247.	3,032.
	23"	72"	14"			<b>ROPO72T0(-)(-)(-)</b>	2,575.	2,665.	3,063.	4,137.
23"	90"	14"			<b>ROPO90T0(-)(-)(-)</b>	2,923.	3,019.	3,473.	4,690.	
23"	96"	14"			<b>ROPO96T0(-)(-)(-)</b>	3,029.	3,131.	3,602.	4,863.	
Panel-hung overhead cabinet (hinged door) no back 	19"	30"	14"	1	2	<b>ROPH30S0(-)(-)(-)</b>	1,378.	1,421.	1,633.	2,205.
	19"	36"	14"	1	2	<b>ROPH36S0(-)(-)(-)</b>	1,683.	1,741.	2,005.	2,706.
	19"	60"	14"	2	4	<b>ROPH60S0(-)(-)(-)</b>	1,964.	2,030.	2,335.	3,153.
	19"	72"	14"	2	4	<b>ROPH72S0(-)(-)(-)</b>	2,407.	2,490.	2,863.	3,866.
	19"	90"	14"	3	6	<b>ROPH90S0(-)(-)(-)</b>	2,650.	2,737.	3,148.	4,248.
	19"	96"	14"	3	6	<b>ROPH96S0(-)(-)(-)</b>	2,744.	2,835.	3,264.	4,406.
	23"	60"	14"	2	4	<b>ROPH60T0(-)(-)(-)</b>	2,102.	2,172.	2,499.	3,375.
	23"	72"	14"	2	4	<b>ROPH72T0(-)(-)(-)</b>	2,861.	2,960.	3,402.	4,593.
	23"	90"	14"	3	6	<b>ROPH90T0(-)(-)(-)</b>	3,245.	3,356.	3,855.	5,205.
	23"	96"	14"	3	6	<b>ROPH96T0(-)(-)(-)</b>	3,367.	3,479.	4,000.	5,401.

Order Code	Specification Information
Example: <b>ROPH60S0DLL</b>	
<b>R</b> Reff	
<b>O</b> Overhead	
<b>P</b> Panel hung	
<b>H</b> Hinge door	
<b>60</b> 60" wide	
<b>S</b> Standard height, 19"h	
<b>0</b> 15" deep	
<b>D</b> D-pull	
<b>L</b> Lock hole drilled	
<b>L</b> Laminate finish	

**To order please specify pattern number including:**

- Configuration option (*embedded in pattern no.*)  
H = Hinged door  
O = Open  
F = Flip door
- Storage option (*embedded in pattern no.*)  
S0 = 19"h x 14"d open/15"d hinged door  
T0 = 23"h x 14"d open/15"d hinged door
- Finish type
- Pull option *applicable hinged doors only*
- Lock option
- Finish, case
- Finish, pull when applicable
- Keying instructions

**\*After specifying product code, provide keying instructions.**

**Dimensions are nominal.**

Product not available where prices do not appear.

3. *Finish type options:*  
L = Laminate  
1 = V1 techwood  
2 = V2 conventional veneer  
3 = V3 exotic veneer

4. *Pull Options:*  
D = Metal D-pull for hinged door only  
J = Routed pull  
C = Nickel finish C-pull for hinged door only (nickel finish only)  
S = Stainless steel finish S-pull for hinged door only (stainless steel finish only)

5. *Lock options:*  
L = Lock hole drilled  
N = No lockdrilling

8. Refer to page 523 for keying instructions.

Woodgrain Laminate is not available on any flip door units.

Applicable finishes are listed on page 5 and 6.

Sliding rails order separately on page 0.

**Application Notes**

Panel-hung cabinets are shipped knocked-down. Wall-hung overhead cabinets are shipped assembled.

Open cabinets require no locks.

Tasklights are not included.

D-Pulls are not available for flip door units.

Hardware included for overhead cabinets.

Knoll does not assume any responsibility for the installation, attachment or the securing of wall hung units to the wall. A certified building contractor should be consulted. Please refer to wall mounting information on page 494.

**\*Keying instructions must accompany all cabinet orders.**

Panel-hung overheads come with no backs.

Random keys are factory installed.

Order overheads with a KnollKey order form.

Overhead storage

# Overhead, 26 1/2" planning

## Panel hung, Single high

Reff Profiles

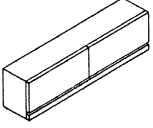
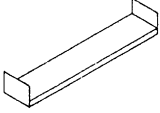
description	h	w	d	locks req'd	doors	pattern no.	L	V1	V2	V3
Panel-hung overhead flip door cabinet (no back) 	18"	30"	14"	1	1	ROPF30S0J-( )()	\$1,035.	\$1,359.	\$1,561.	\$2,108.
	18"	36"	14"	1	1	ROPF36S0J-( )()	1,052.	1,383.	1,592.	2,149.
	18"	42"	14"	1	1	ROPF42S0J-( )()	1,126.	1,483.	1,706.	2,304.
	18"	48"	14"	1	1	ROPF48S0J-( )()	1,168.	1,542.	1,772.	2,393.
	18"	60"	14"	2	2	ROPF60S0J-( )()	1,356.	1,783.	2,052.	2,771.
	18"	72"	14"	2	2	ROPF72S0J-( )()	1,603.	2,110.	2,424.	3,272.
	18"	84"	14"	2	2	ROPF84S0J-( )()	1,791.	2,356.	2,709.	3,658.
	18"	96"	14"	2	2	ROPF96S0J-( )()	1,910.	2,514.	2,893.	3,904.
Panel-hung shelves 	9"	30"	13"			ROPS30S0NN-( )	278.	573.	658.	889.
	9"	36"	13"			ROPS36S0NN-( )	300.	595.	684.	923.
	9"	42"	13"			ROPS42S0NN-( )	325.	615.	709.	957.
	9"	48"	13"			ROPS48S0NN-( )	347.	637.	730.	986.
	9"	54"	13"			ROPS54S0NN-( )	371.	684.	785.	1,060.
	9"	60"	13"			ROPS60S0NN-( )	396.	736.	846.	1,142.
	9"	66"	13"			ROPS66S0NN-( )	419.	783.	900.	1,215.
	9"	72"	13"			ROPS72S0NN-( )	443.	834.	956.	1,289.
	9"	78"	13"			ROPS78S0NN-( )	467.	903.	1,038.	1,400.
	9"	84"	13"			ROPS84S0NN-( )	489.	972.	1,119.	1,511.
	9"	90"	13"			ROPS90S0NN-( )	514.	1,043.	1,198.	1,618.
9"	96"	13"			ROPS96S0NN-( )	521.	1,096.	1,263.	1,705.	

Order Code	Specification Information	Application Notes	
Example: <b>ROPH60S0DLL</b> <b>R</b> Reff <b>O</b> Overhead <b>P</b> Panel hung <b>H</b> Hinge door <b>60</b> 60" wide <b>S</b> Standard height, 19"h <b>0</b> 15" deep <b>D</b> D-pull <b>L</b> Lock hole drilled <b>L</b> Laminate finish	<p>To order please specify pattern number including:</p> <ol style="list-style-type: none"> <li>Configuration option (embedded in pattern no.)  <i>H</i> = Hinged door  <i>O</i> = Open  <i>F</i> = Flip door</li> <li>Storage option (embedded in pattern no.)  <i>S0</i> = 19"h x 14"d open/15"d hinged door  <i>T0</i> = 23"h x 14"d open/15"d hinged door</li> <li>Finish type</li> <li>Pull option applicable hinged doors only</li> <li>Lock option</li> <li>Finish, case</li> <li>Finish, pull when applicable</li> <li>Keying instructions</li> </ol> <p><b>*After specifying product code, provide keying instructions.</b></p> <p><b>Dimensions are nominal.</b></p> <p>Product not available where prices do not appear.</p> <ol style="list-style-type: none"> <li>Finish type options:            L = Laminate            1 = V1 techwood            2 = V2 conventional veneer            3 = V3 exotic veneer</li> </ol>	<p><b>4. Pull Options:</b>            D = Metal D-pull for hinged door only            J = Routed pull            C = Nickel finish C-pull for hinged door only (nickel finish only)            S = Stainless steel finish S-pull for hinged door only (stainless steel finish only)</p> <p><b>5. Lock options:</b>            L = Lock hole drilled            N = No lockdrilling</p> <p><b>8. Refer to page 523 for keying instructions.</b></p> <p>Woodgrain Laminate is not available on any flip door units.</p> <p>Applicable finishes are listed on page 5 and 6.</p> <p>Sliding rails order separately on page 0.</p>	<p>Panel-hung cabinets are shipped knocked-down. Wall-hung overhead cabinets are shipped assembled.</p> <p>Open cabinets require no locks.</p> <p>Tasklights are not included.</p> <p>D-Pulls are not available for flip door units.</p> <p>Hardware included for overhead cabinets.</p> <p>Knoll does not assume any responsibility for the installation, attachment or the securing of wall hung units to the wall.</p> <p>A certified building contractor should be consulted.</p> <p>Please refer to wall mounting information on page 494.</p> <p><b>*Keying instructions must accompany all cabinet orders.</b></p> <p>Panel-hung overheads come with no backs.</p> <p>Random keys are factory installed.</p> <p>Order overheads with a KnollKey order form.</p>

# Overhead, 26 1/2" planning Workwalls

Reff Profiles

description	d	h	w	pattern no.	L	V1	V2	V3
72" h workwall overhead cabinet (open)	15"	19"	60"	ROWO60S0(-)(-)(-)	\$1,974.	\$2,061.	\$2,416.	\$3,263.
	15"	19"	72"	ROWO72S0(-)(-)(-)	2,537.	2,650.	3,099.	4,183.
	15"	19"	90"	ROWO90S0(-)(-)(-)	2,796.	2,924.	3,441.	4,644.
	15"	19"	96"	ROWO96S0(-)(-)(-)	2,863.	3,001.	3,533.	4,770.
	15"	23"	60"	ROWO60T0(-)(-)(-)	2,144.	2,238.	2,624.	3,543.
	15"	23"	72"	ROWO72T0(-)(-)(-)	2,881.	3,005.	3,510.	4,738.
	15"	23"	90"	ROWO90T0(-)(-)(-)	3,231.	3,377.	3,956.	5,342.
	15"	23"	96"	ROWO96T0(-)(-)(-)	3,298.	3,450.	4,050.	5,469.
	20"	19"	60"	ROWO60S1(-)(-)(-)	2,122.	2,216.	2,597.	3,505.
	20"	19"	72"	ROWO72S1(-)(-)(-)	2,725.	2,842.	3,321.	4,484.
	20"	19"	90"	ROWO90S1(-)(-)(-)	3,106.	3,248.	3,813.	5,147.
	20"	19"	96"	ROWO96S1(-)(-)(-)	3,178.	3,324.	3,906.	5,275.
	20"	23"	60"	ROWO60T1(-)(-)(-)	2,293.	2,392.	2,802.	3,781.
	20"	23"	72"	ROWO72T1(-)(-)(-)	3,175.	3,310.	3,859.	5,209.
	20"	23"	90"	ROWO90T1(-)(-)(-)	3,433.	3,587.	4,200.	5,670.
20"	23"	96"	ROWO96T1(-)(-)(-)	3,505.	3,660.	4,292.	5,794.	

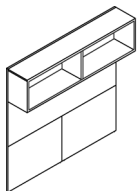

72" h workwall overhead cabinet (hinged door)	15"	19"	60"	ROWH60S0(-)(-)(-)	2,547.	2,654.	3,100.	4,184.
	15"	19"	72"	ROWH72S0(-)(-)(-)	3,264.	3,397.	3,962.	5,349.
	15"	19"	90"	ROWH90S0(-)(-)(-)	3,623.	3,785.	4,429.	5,978.
	15"	19"	96"	ROWH96S0(-)(-)(-)	3,724.	3,889.	4,558.	6,152.
	15"	23"	60"	ROWH60T0(-)(-)(-)	2,761.	2,877.	3,358.	4,533.
	15"	23"	72"	ROWH72T0(-)(-)(-)	3,695.	3,845.	4,473.	6,040.
	15"	23"	90"	ROWH90T0(-)(-)(-)	4,169.	4,345.	5,075.	6,850.
	15"	23"	96"	ROWH96T0(-)(-)(-)	4,268.	4,452.	5,204.	7,025.
	20"	19"	60"	ROWH60S1(-)(-)(-)	2,734.	2,848.	3,324.	4,488.
	20"	19"	72"	ROWH72S1(-)(-)(-)	3,498.	3,641.	4,239.	5,722.
	20"	19"	90"	ROWH90S1(-)(-)(-)	4,016.	4,189.	4,891.	6,604.
	20"	19"	96"	ROWH96S1(-)(-)(-)	4,116.	4,293.	5,022.	6,780.
	20"	23"	60"	ROWH60T1(-)(-)(-)	2,950.	3,072.	3,579.	4,832.
	20"	23"	72"	ROWH72T1(-)(-)(-)	4,062.	4,224.	4,910.	6,629.
	20"	23"	90"	ROWH90T1(-)(-)(-)	4,425.	4,610.	5,377.	7,260.
	20"	23"	96"	ROWH96T1(-)(-)(-)	4,522.	4,714.	5,506.	7,433.

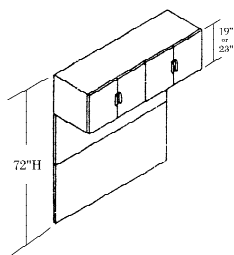

60" w and 72" w units have four hinged doors, two lock cores required.  
90" w and 96" w have six hinged doors, three lock cores required.

Order Code	Specification Information	Application Notes
Example: <b>ROWO60S0L</b>	<i>To order please specify pattern number including:</i>	Shipped knocked-down.
<b>R</b> Reff	1. Configuration option	Open cabinets require no locks.
<b>O</b> Overhead	2. Storage option ( <i>embedded in pattern no.</i> )	Tasklights not included.
<b>W</b> Workwall	<i>S0 = 19" h x 15" d</i>	Tackboard included, fabric railroaded.
<b>O</b> Open	<i>S1 = 19" h x 20" d</i>	Locks are not factory installed.
<b>60</b> 60" wide	<i>T0 = 23" h x 15" d</i>	If attaching workwall to 72" high cabinets for support, please provide drawing of layout.
<b>S</b> Standard height	<i>T1 = 23" h x 20" d</i>	Applicable finishes are listed on page 5 and 6.
<b>0</b> 15" deep	3. Finish type	Product on this page excluding J-pull option will accept woodgrain laminate where laminate is currently an option.
<b>L</b> Laminate finish	4. Pull option for hinged door only.	List price for woodgrain laminate options will be current published laminate list price plus 10%.
<b>(W250)</b> Fabric finish Regency	5. Lock option	
	6. Finish	
	7. Pull finish when applicable	
	8. Fabric for tackboard	
	<b>*After specifying product code, provide keying instructions. I.</b>	
	<i>Configuration options:</i>	
	O = Open	
	H = Hinged door	
	3. Finish type:	
	L = Laminate	
	1 = V1	
	2 = V2	
	3 = V3	
	4. Pull Options:	
	D = Metal D-pull for hinged door only	
	J = Routed pull	
	C = Nickel C-pull for hinged door only (nickel finish only)	
	S = Stainless steel finish S-pull for hinged door only (stainless steel finish only)	
	5. Lock options:	
	L = Lockhole drilled	
	N = No lock drilling	
	<i>Keying instructions *</i>	
	<b>See Planning Guide for keying examples.</b>	

Overhead storage

# Overhead, 26 1/2" planning Shoulders

description	d	h	w	pattern no.	L	V1	V2	V3
Workwall support endpanels for 72"H x 20"D workwall cabinets	15"	19"	-	<b>RWEA7220(L/R)-()</b>	\$368.	\$379.	\$435.	\$587.
	15"	23"	-	<b>RWEB7220(L/R)-()</b>	368.	379.	435.	587.
	20"	19"	-	<b>RWEC7220(L/R)-()</b>	368.	379.	435.	587.
	20"	23"	-	<b>RWED7220(L/R)-()</b>	368.	379.	435.	587.



Workwall support endpanels for 72"H x 24"D workwall cabinets	15"	19"	-	<b>RWEA7224(L/R)-()</b>	400.	415.	476.	643.
	15"	23"	-	<b>RWEB7224(L/R)-()</b>	400.	415.	476.	643.
	20"	19"	-	<b>RWEC7224(L/R)-()</b>	400.	415.	476.	643.
	20"	23"	-	<b>RWED7224(L/R)-()</b>	400.	415.	476.	643.



Order Code	Specification Information	Application Notes
Example: <b>ROWO60S0L</b>	<i>To order please specify pattern number including:</i>	Shipped knocked-down.
<b>R</b> Reff	1. Configuration option	Open cabinets require no locks.
<b>O</b> Overhead	2. Storage option ( <i>embedded in pattern no.</i> )	Tasklights not included.
<b>W</b> Workwall	<i>S0 = 19"h x 15"d</i>	Tackboard included, fabric railroaded.
<b>O</b> Open	<i>S1 = 19"h x 20"d</i>	Locks are not factory installed.
<b>60</b> 60" wide	<i>T0 = 23"h x 15"d</i>	If attaching workwall to 72" high cabinets for support, please provide drawing of layout.
<b>S</b> Standard height	<i>T1 = 23"h x 20"d</i>	Applicable finishes are listed on page 5 and 6.
<b>0</b> 15" deep	3. Finish type:	Product on this page excluding J-pull option will accept woodgrain laminate where laminate is currently an option.
<b>L</b> Laminate finish	4. Pull option for hinged door only.	List price for woodgrain laminate options will be current published laminate list price plus 10%.
<b>(W250)</b> Fabric finish Regency	5. Lock option	
	6. Finish	
	7. Pull finish when applicable	
	8. Fabric for tackboard	
	<b>*After specifying product code, provide keying instructions.1.</b>	
	<i>Configuration options:</i>	
	O = Open	
	H = Hinged door	
	3. Finish type:	
	L = Laminate	
	1 = V1	
	2 = V2	
	3 = V3	
	4. Pull Options:	
	D = Metal D-pull for hinged door only	
	J = Routed pull	
	C = Nickel C-pull for hinged door only (nickel finish only)	
	S = Stainless steel finish S-pull for hinged door only (stainless steel finish only)	
	5. Lock options:	
	L = Lockhole drilled	
	N = No lock drilling	
	<i>Keying instructions *</i>	
	<b>See Planning Guide for keying examples.</b>	

# Overhead, 26 1/2" planning Use with 1 1/4" worksurfaces overdesk unit

description	d	w	h	locks req'd	doors	pattern no.	L	V1	V2	V3
For 1 1/4" worksurfaces (hinged door)	15"	60"	44 1/4"	2	4	ROAH60T0(-)(-)(-)	\$2,492.	\$3,128.	\$3,655.	\$4,935.
	15"	72"	44 1/4"	2	4	ROAH72T0(-)(-)(-)	3,158.	3,956.	4,615.	6,231.
	15"	90"	44 1/4"	3	6	ROAH90T0(-)(-)(-)	3,512.	4,403.	5,157.	6,962.
	15"	96"	44 1/4"	3	6	ROAH96T0(-)(-)(-)	3,657.	4,593.	5,384.	7,268.
	20"	60"	44 1/4"	2	4	ROAH60T1(-)(-)(-)	2,637.	3,308.	3,857.	5,206.
	20"	72"	44 1/4"	2	4	ROAH72T1(-)(-)(-)	3,334.	4,176.	4,866.	6,569.
	20"	90"	44 1/4"	3	6	ROAH90T1(-)(-)(-)	3,715.	4,659.	5,449.	7,357.
	20"	96"	44 1/4"	3	6	ROAH96T1(-)(-)(-)	3,872.	4,860.	5,688.	7,680.

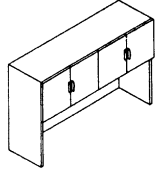

For 1 1/4" worksurfaces (open)	15"	60"	44 1/4"			ROAO60T0(-)(-)(-)	1,648.	2,074.	2,445.	3,300.
	15"	72"	44 1/4"			ROAO72T0(-)(-)(-)	2,103.	2,641.	3,103.	4,189.
	15"	90"	44 1/4"			ROAO90T0(-)(-)(-)	2,301.	2,901.	3,431.	4,632.
	15"	96"	44 1/4"			ROAO96T0(-)(-)(-)	2,388.	3,015.	3,567.	4,814.
	20"	60"	44 1/4"			ROAO60T1(-)(-)(-)	1,751.	2,200.	2,587.	3,494.
	20"	72"	44 1/4"			ROAO72T1(-)(-)(-)	2,226.	2,796.	3,280.	4,429.
	20"	90"	44 1/4"			ROAO90T1(-)(-)(-)	2,442.	3,080.	3,628.	4,899.
	20"	96"	44 1/4"			ROAO96T1(-)(-)(-)	2,536.	3,202.	3,779.	5,101.

For 1 1/4" worksurfaces (flip door)	15"	60"	44 1/4"	2	2	ROAF60S0(-)(-)(-)	2,133.	2,906.	3,397.	4,587.
	15"	72"	44 1/4"	2	2	ROAF72S0(-)(-)(-)	2,533.	3,683.	4,299.	5,804.
	15"	84"	44 1/4"	2	2	ROAF84S0(-)(-)(-)	3,282.	4,198.	4,909.	6,626.
	15"	96"	44 1/4"	2	2	ROAF96S0(-)(-)(-)	3,361.	4,312.	5,059.	6,829.
	20"	60"	44 1/4"	2	2	ROAF60S1(-)(-)(-)	2,258.	3,077.	3,594.	4,853.
	20"	72"	44 1/4"	2	2	ROAF72S1(-)(-)(-)	2,676.	3,889.	4,537.	6,125.
	20"	84"	44 1/4"	2	2	ROAF84S1(-)(-)(-)	3,470.	4,440.	5,188.	7,003.
	20"	96"	44 1/4"	2	2	ROAF96S1(-)(-)(-)	3,559.	4,567.	5,352.	7,224.

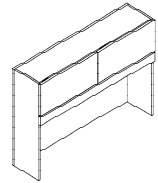

Order Code	Specification Information	Application Notes
Example: <b>ROAF60S0LJLBF118(-)</b>	<i>To order please specify pattern number including:</i>	Shipped knocked-down.
<b>R</b> Reff	1. <i>Configuration option</i> O = Open H = Hinged door F = Flip door	Open cabinets require no locks.
<b>O</b> Overhead	2. <i>Width</i>	Tasklights not included.
<b>A</b> For 1 1/4" top mounting	3. <i>Storage option</i> S0 = 19"h x 15"d S1 = 19"h x 20"d T0 = 23"h x 15"d T1 = 23"h x 20"d	Tackboard included, fabric railroaded.
<b>F</b> Flip door	4. <i>Finish type</i> L = Laminate 1 = V1 2 = V2 3 = V3	C, D and S pulls are not available for flip door units.
<b>60</b> 60" wide	5. <i>Pull option for hinged door only</i> D = Metal D-pull (for hinged doors only) J = Routed pull C = Nickel C-pull (nickel finish only, for hinged doors only) S = Stainless steel finish S-pull (stainless steel finish only, for hinged doors only)	All flip door cabinets on this page are nominal 19"H not 23"H.
<b>S</b> Standard height		Open/hinge doors are nominal 23"H, actual 22 3/8".
<b>0</b> 15" deep		Locks are not factory installed.
<b>L</b> Finish type, laminate		Include grommet (black only) in back panel for task light cord. If used in open plan areas specify "no grommet."
<b>J</b> J-pull		Wire manager is included and mounts adjacent to tackboard. Specify color.
<b>L</b> Locks included		
<b>BF</b> Cord escape, back feed		
<b>118</b> Finish, Bright White		
<b>(W250)</b> Fabric		
	6. <i>Lock option</i> L = Lockhole drilled N = No lock drilling	
	7. Cord escape option	
	8. Finish	
	9. Pull finish where applicable	
	10. Fabric for tackboard	
	Woodgrain Laminate is not available on any flip door units.	
	<b>*After specifying product code, provide keying instructions.</b>	
	Overdesk unit will achieve 72" nominal height when used with correct top.	
	The clearance under the overhead to the top of the worksurface is approximately 21 1/4".	
	Applicable finishes are listed on page 5 and 6.	

# Overhead, 26 1/2" planning Use with 1 3/4" worksurfaces overdesk unit

description	d	w	he	locks req'd	doors	pattern no.	L	V1	V2	V3
For 1 3/4" worksurfaces (hinged door)	15"	60"	43 3/4"	2	4	<b>ROBH60T0(-)(-)(-)</b>	\$2,521.	\$3,161.	\$3,693.	\$4,987.
	15"	72"	43 3/4"	2	4	<b>ROBH72T0(-)(-)(-)</b>	3,195.	4,000.	4,666.	6,300.
	15"	90"	43 3/4"	3	6	<b>ROBH90T0(-)(-)(-)</b>	3,550.	4,455.	5,214.	7,039.
	15"	96"	43 3/4"	3	6	<b>ROBH96T0(-)(-)(-)</b>	3,702.	4,646.	5,444.	7,350.
	20"	60"	43 3/4"	2	4	<b>ROBH60T1(-)(-)(-)</b>	2,669.	3,341.	3,902.	5,269.
	20"	72"	43 3/4"	2	4	<b>ROBH72T1(-)(-)(-)</b>	3,373.	4,223.	4,921.	6,643.
	20"	90"	43 3/4"	3	6	<b>ROBH90T1(-)(-)(-)</b>	3,756.	4,714.	5,509.	7,437.
	20"	96"	43 3/4"	3	6	<b>ROBH96T1(-)(-)(-)</b>	3,916.	4,915.	5,755.	7,768.

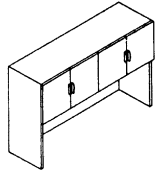

For 1 3/4" worksurfaces (open)	15"	60"	43 3/4"			<b>ROBO60T0(-)(-)(-)</b>	1,666.	2,102.	2,471.	3,334.
	15"	72"	43 3/4"			<b>ROBO72T0(-)(-)(-)</b>	2,112.	2,673.	3,139.	4,236.
	15"	90"	43 3/4"			<b>ROBO90T0(-)(-)(-)</b>	2,327.	2,936.	3,470.	4,684.
	15"	96"	43 3/4"			<b>ROBO96T0(-)(-)(-)</b>	2,415.	3,051.	3,608.	4,871.
	20"	60"	43 3/4"			<b>ROBO60T1(-)(-)(-)</b>	1,768.	2,228.	2,616.	3,532.
	20"	72"	43 3/4"			<b>ROBO72T1(-)(-)(-)</b>	2,252.	2,828.	3,316.	4,475.
	20"	90"	43 3/4"			<b>ROBO90T1(-)(-)(-)</b>	2,418.	3,054.	3,615.	4,880.
	20"	96"	43 3/4"			<b>ROBO96T1(-)(-)(-)</b>	2,475.	3,118.	3,676.	4,962.

For 1 3/4" worksurfaces (flip door)	15"	60"	43 3/4"	2	2	<b>ROBF60S0(-)(-)(-)</b>	2,157.	2,941.	3,438.	4,641.
	15"	72"	43 3/4"	2	2	<b>ROBF72S0(-)(-)(-)</b>	2,562.	3,725.	4,348.	5,870.
	15"	84"	43 3/4"	2	2	<b>ROBF84S0(-)(-)(-)</b>	3,320.	4,242.	4,962.	6,700.
	15"	96"	43 3/4"	2	2	<b>ROBF96S0(-)(-)(-)</b>	3,401.	4,365.	5,118.	6,910.
	20"	60"	43 3/4"	2	2	<b>ROBF60S1(-)(-)(-)</b>	2,285.	3,108.	3,633.	4,905.
	20"	72"	43 3/4"	2	2	<b>ROBF72S1(-)(-)(-)</b>	2,707.	3,933.	4,588.	6,194.
	20"	84"	43 3/4"	2	2	<b>ROBF84S1(-)(-)(-)</b>	3,513.	4,493.	5,251.	7,090.
	20"	96"	43 3/4"	2	2	<b>ROBF96S1(-)(-)(-)</b>	3,602.	4,619.	5,409.	7,302.

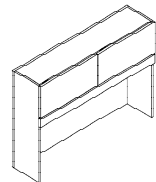

Order Code	Specification Information	Application Notes
Example: <b>ROBF60S0LJLBF118(-)</b>	<i>To order please specify pattern number including:</i>	Shipped knocked-down.
<b>R</b> Reff	1. <i>Configuration option</i> O = Open H = Hinged door F = Flip door	Open cabinets require no locks.
<b>O</b> Overhead	2. <i>Width</i>	Tasklights not included.
<b>B</b> For 1 3/4" top mounting	3. <i>Storage option</i> S0 = 19"h x 15"d S1 = 19"h x 20"d T0 = 23"h x 15"d T1 = 23"h x 20"d	Tackboard included, fabric railroded.
<b>F</b> Flip door	4. <i>Finish type</i> L = Laminate 1 = V1 2 = V2 3 = V3	C, D and S pulls are not available for flip door units.
<b>60</b> 60" wide	5. <i>Pull option for hinged door only</i> D = Metal D-pull (for hinged doors only) J = Routed pull C = Nickel C-pull (nickel finish only, for hinged doors only) S = Stainless steel finish S-pull (stainless steel finish only, for hinged doors only)	All flip door cabinets on this page are nominal 19"H not 23"H.
<b>S</b> Standard height		Open/hinge doors are nominal 23"H, actual 22 3/8".
<b>0</b> 15" deep		Locks are not factory installed.
<b>L</b> Finish type, laminate		Include grommet (black only) in back panel for task light cord. If used in open plan areas specify "no grommet."
<b>J</b> J-pull		Wire manager is included and mounts adjacent to tackboard. Specify color.
<b>L</b> Locks included		
<b>BF</b> Cord escape, back feed		
<b>118</b> Finish, Bright White		
<b>(W250)</b> Fabric		
	6. <i>Lock option</i> L = Lockhole drilled N = No lock drilling	
	7. <i>Cord escape option</i>	
	8. <i>Finish</i>	
	9. <i>Pull finish where applicable</i>	
	10. <i>Fabric for tackboard</i>	
	<b>*After specifying product code, provide keying instructions.</b>	
	Overdesk unit will achieve 72" nominal height when used with correct top.	
	The clearance under the overhead to the top of the worksurface is approximately 20 3/4".	
	Applicable finishes are listed on page 5 and 6.	
	Woodgrain Laminate is not available on any flip door units.	

Overhead, 26 1/2" planning  
 rectilinear worksurfaces for workwall units  
 1 1/4" thick

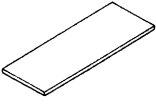
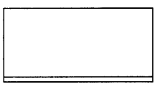
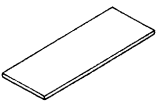
description	w	d	pattern no.	L	M/V1	V2	V3
Straight workwall Rectangular tops 	60"	20"	<b>RSWWA601( )</b>	\$575.	\$593.	\$680.	\$919.
	60"	24"	<b>RSWWA602( )</b>	618.	637.	734.	990.
	72"	20"	<b>RSWWA721( )</b>	625.	646.	742.	1,000.
	72"	24"	<b>RSWWA722( )</b>	668.	692.	792.	1,070.
	90"	20"	<b>RSWWA901( )</b>	724.	749.	861.	1,162.
	90"	24"	<b>RSWWA902( )</b>	768.	792.	914.	1,233.
	96"	20"	<b>RSWWA961( )</b>	822.	849.	976.	1,318.
	96"	24"	<b>RSWWA962( )</b>	867.	896.	1,029.	1,389.
Waterfall edge workwall tops 	60"	20"	<b>RSWWAWF601( )</b>	n/a	1,781.	2,049.	2,765.
	60"	24"	<b>RSWWAWF602( )</b>	n/a	1,912.	2,200.	2,970.
	72"	20"	<b>RSWWAWF721( )</b>	n/a	1,936.	2,227.	3,005.
	72"	24"	<b>RSWWAWF722( )</b>	n/a	2,070.	2,383.	3,218.
	90"	20"	<b>RSWWAWF901( )</b>	n/a	2,248.	2,585.	3,491.
	90"	24"	<b>RSWWAWF902( )</b>	n/a	2,383.	2,742.	3,700.
	96"	20"	<b>RSWWAWF961( )</b>	n/a	2,620.	2,929.	3,954.
	96"	24"	<b>RSWWAWF962( )</b>	n/a	2,686.	3,090.	4,170.
Straight workwall 1 1/4" Rectangular tops with front edge profile 	60"	20"	<b>RSWWA(A/B/C/D/E/F/G)601( )</b>	n/a	680.	785.	1,060.
	60"	24"	<b>RSWWA(A/B/C/D/E/F/G)602( )</b>	n/a	733.	845.	1,141.
	72"	20"	<b>RSWWA(A/B/C/D/E/F/G)721( )</b>	n/a	742.	853.	1,152.
	72"	24"	<b>RSWWA(A/B/C/D/E/F/G)722( )</b>	n/a	793.	914.	1,233.
	90"	20"	<b>RSWWA(A/B/C/D/E/F/G)901( )</b>	n/a	861.	990.	1,337.
	90"	24"	<b>RSWWA(A/B/C/D/E/F/G)902( )</b>	n/a	913.	1,050.	1,417.
	96"	20"	<b>RSWWA(A/B/C/D/E/F/G)961( )</b>	n/a	976.	1,124.	1,517.
	96"	24"	<b>RSWWA(A/B/C/D/E/F/G)962( )</b>	n/a	1,029.	1,184.	1,598.

Order Code	Specification Information
Example: <b>RSWWA60100L</b>	
<b>R</b>	Reff
<b>S</b>	Straight top
<b>WW</b>	Workwall top
<b>A</b>	1 1/4" thick
<b>60</b>	60" wide
<b>1</b>	20" deep
<b>(L)</b>	Laminate finish

**Specification Information**

To order please specify pattern number including:

- Top thickness
- Top finish type
- Top finish

1. Thickness options:  
 A = 1 1/4"

2. Finish type:  
 L = Laminate  
 M = Wood/laminate mixed  
 1 = V1  
 2 = V2  
 3 = V3

3. Specify edge detail where applicable, for RSWWA( ). See page0 for available profiles.

Product on this page will accept woodgrain laminate where laminate is currently an option. List price for woodgrain laminate options will be current published laminate list price plus 10%.

**Application Notes**

20" and 24" depth dimensions are given so specifier may more easily match top to pedestal depth or lateral file depth. These tops are actually less deep than the indicated dimension because they incorporate wire management channel along their backs.

No grommets available.

1 3/4" thick laminate option is double post formed front and back, all others are edgebanded.

Applicable finishes are listed on page 5 and 6.  
**Hardware included.**

Overhead, 26<sup>1</sup>/<sub>2</sub>" planning  
*rectilinear worksurfaces for workwall units*  
*1<sup>3</sup>/<sub>4</sub>" thick*

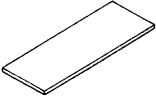
description	w	d	pattern no.	L	M/V1	V2	V3
Straight workwall Rectangular tops 	60"	20"	<b>RSWWB601()</b>	\$718.	\$746.	\$855.	\$1,155.
	60"	24"	<b>RSWWB602()</b>	770.	801.	921.	1,244.
	72"	20"	<b>RSWWB721()</b>	782.	813.	935.	1,262.
	72"	24"	<b>RSWWB722()</b>	834.	868.	998.	1,348.
	90"	20"	<b>RSWWB901()</b>	904.	941.	1,082.	1,462.
	90"	24"	<b>RSWWB902()</b>	962.	999.	1,148.	1,550.
	96"	20"	<b>RSWWB961()</b>	1,026.	1,066.	1,224.	1,653.
	96"	24"	<b>RSWWB962()</b>	1,083.	1,125.	1,293.	1,746.

Order Code	Specification Information	Application Notes
Example: <b>RSWWB60100L</b> <b>R</b> Reff <b>S</b> Straight top <b>WW</b> Workwall top <b>B</b> 1 <sup>3</sup> / <sub>4</sub> " thick <b>60</b> 60" wide <b>1</b> 20" deep <b>(L)</b> Laminate finish	To order please specify pattern number including: 1. Top thickness 2. Top finish type 3. Top finish  1. Thickness options: B = 1 <sup>3</sup> / <sub>4</sub> "  2. Finish type: L = Laminate M = Wood/laminate mixed 1 = V1 2 = V2 3 = V3  3. Specify edge detail where applicable, for RSWWA(). See page 0 for available profiles.	20" and 24" depth dimensions are given so specifier may more easily match top to pedestal depth or lateral file depth. These tops are actually less deep than the indicated dimension because they incorporate wire management channel along their backs.  No grommets available.  1 <sup>3</sup> / <sub>4</sub> " thick laminate option is double post formed front and back, all others are edgebanded.  Applicable finishes are listed on page 5 and 6.  <b>Hardware included.</b>



# Overhead, 28<sup>3</sup>/<sub>8</sub>" planning Workwalls

description	d	h	w	overall height	pattern no.	L	V1	V2	V3
Workwall, (for "desk height") 19"h storage (open)	15"	19"	60"	75"	ROWO60S0DH ( ) ( ) ( ) ( )	\$2,071.	\$2,164.	\$2,537.	\$3,427.
	15"	19"	72"	75"	ROWO72S0DH ( ) ( ) ( ) ( )	2,665.	2,782.	3,254.	4,393.
	15"	19"	90"	75"	ROWO90S0DH ( ) ( ) ( ) ( )	2,938.	3,071.	3,611.	4,874.
	15"	19"	96"	75"	ROWO96S0DH ( ) ( ) ( ) ( )	3,008.	3,152.	3,710.	5,008.
	20"	19"	60"	75"	ROWO60S1DH ( ) ( ) ( ) ( )	2,229.	2,326.	2,726.	3,679.
	20"	19"	72"	75"	ROWO72S1DH ( ) ( ) ( ) ( )	2,861.	2,982.	3,484.	4,706.
	20"	19"	90"	75"	ROWO90S1DH ( ) ( ) ( ) ( )	3,261.	3,410.	4,004.	5,406.
	20"	19"	96"	75"	ROWO96S1DH ( ) ( ) ( ) ( )	3,339.	3,491.	4,102.	5,539.

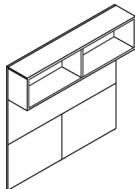

Order Code	Specification Information	Application Notes
Example: <b>ROWO60S0DHL118( )</b>	<i>To order please specify pattern number including:</i>	<p>Products on this page are engineered to align with 75" h cabinets on page 0. Be sure storage dimension options and drilling options correspond accordingly. For storage options below the worksurface, specify 28<sup>3</sup>/<sub>8</sub>" h products on page 0 ; <b>do not mix products from 26<sup>1</sup>/<sub>2</sub>" h (standard height) planning model with 28<sup>3</sup>/<sub>8</sub>" h (desk height) planning model in any one configuration.</b></p> <p>75" nominal height - actual height 75.125"</p> <p>If attaching workwall to 75" cabinet(s) for support, please provide drawing of layout with order.</p> <p>Tackboard included with workwall; fabric applied railroaded.</p> <p>Tasklights to be ordered separately</p>
<b>R</b> Reff	1. <i>Configuration option (embedded in pattern number)</i> O = Open H = Hinged doors	
<b>O</b> Overhead	2. <i>Storage option (embedded in pattern number)</i> S0 = 19" h x 15" d S1 = 19" h x 20" d T0 = 23" h x 15" d T1 = 23" h x 20" d	
<b>W</b> Workwall	3. <i>Finish type</i> L = laminate 1 = V1 2 = V2 3 = V3	
<b>O</b> Open	4. <i>Pull option</i> (Optional hinged door configurations only) D = metal D-pull (finish optional) J = routed J-pull (finish matches case) C = nickel finish C-pull (nickel finish only) S = S-pull (stainless steel finish only)	
<b>60</b> 60" wide	5. <i>Lock option</i> (Optional hinged door configurations only) L = drilled to accept lock N = no drilling	
<b>S</b> 19" storage height	6. <i>Finish</i>	
<b>0</b> 15" storage depth	7. <i>Optional pull finish, where applicable</i>	
<b>DH</b> desk height, 75" height overall	8. <i>Fabric for tackboard</i>	
<b>L</b> Finish type, laminate	Product on this page excluding J-pull option will accept woodgrain laminate where laminate is currently an option. List price for woodgrain laminate options will be current published laminate list price plus 10%.	
<b>118</b> Finish, Bright White	Workwalls do not come with lock included. Keying instructions must accompany all orders, refer to page 523. Random locks are factory installed. Key-alike are field installed using the KnollKey order form.	
<b>( )</b> Fabric selection	Products on this page, shipped knocked-down.  Applicable finishes are listed on page 5 and 6.	

dimensions noted nominal

Overhead storage

# Overhead, 28<sup>3</sup>/<sub>8</sub>" planning Workwalls

description	d	h	w	overall height	pattern no.	L	V1	V2	V3
Workwall, (for "desk height") 23"h storage (open)	15"	23"	60"	75"	<b>ROWO60T0DH</b> ( ) ( ) ( ) ( )	\$2,253.	\$2,351.	\$2,756.	\$3,721.
	15"	23"	72"	75"	<b>ROWO72T0DH</b> ( ) ( ) ( ) ( )	3,027.	3,155.	3,686.	4,976.
	15"	23"	90"	75"	<b>ROWO90T0DH</b> ( ) ( ) ( ) ( )	3,393.	3,546.	4,155.	5,610.
	15"	23"	96"	75"	<b>ROWO96T0DH</b> ( ) ( ) ( ) ( )	3,464.	3,623.	4,254.	5,742.
	20"	23"	60"	75"	<b>ROWO60T1DH</b> ( ) ( ) ( ) ( )	2,409.	2,512.	2,943.	3,971.
	20"	23"	72"	75"	<b>ROWO72T1DH</b> ( ) ( ) ( ) ( )	3,334.	3,476.	4,050.	5,469.
	20"	23"	90"	75"	<b>ROWO90T1DH</b> ( ) ( ) ( ) ( )	3,604.	3,766.	4,412.	5,955.
	20"	23"	96"	75"	<b>ROWO96T1DH</b> ( ) ( ) ( ) ( )	3,679.	3,842.	4,507.	6,083.

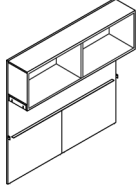

Order Code	Specification Information	Application Notes
Example: <b>ROWO60S0DHL118</b> ( )	<i>To order please specify pattern number including:</i>	<p>Products on this page are engineered to align with 75" h cabinets on page 0. Be sure storage dimension options and drilling options correspond accordingly. For storage options below the worksurface, specify 28<sup>3</sup>/<sub>8</sub>" h products on page 0 ; <b>do not mix products from 26<sup>1</sup>/<sub>2</sub>" h (standard height) planning model with 28<sup>3</sup>/<sub>8</sub>" h (desk height) planning model in any one configuration.</b></p> <p>75" nominal height - actual height 75.125"</p> <p>If attaching workwall to 75" cabinet(s) for support, please provide drawing of layout with order.</p> <p>Tackboard included with workwall; fabric applied railroaded.</p> <p>Tasklights to be ordered separately</p>
<b>R</b> Reff	1. <i>Configuration option (embedded in pattern number)</i> O = Open H = Hinged doors	
<b>O</b> Overhead	2. <i>Storage option (embedded in pattern number)</i> S0 = 19" h x 15" d S1 = 19" h x 20" d T0 = 23" h x 15" d T1 = 23" h x 20" d	
<b>W</b> Workwall	3. <i>Finish type</i> L = laminate 1 = V1 2 = V2 3 = V3	
<b>O</b> Open	4. <i>Pull option</i> (Optional hinged door configurations only) D = metal D-pull (finish optional) J = routed J-pull (finish matches case) C = nickel finish C-pull (nickel finish only) S = S-pull (stainless steel finish only)	
<b>60</b> 60" wide	5. <i>Lock option</i> (Optional hinged door configurations only) L = drilled to accept lock N = no drilling	
<b>S</b> 19" storage height	6. <i>Finish</i>	
<b>0</b> 15" storage depth	7. <i>Optional pull finish, where applicable</i>	
<b>DH</b> desk height, 75" height overall	8. <i>Fabric for tackboard</i>	
<b>L</b> Finish type, laminate	Product on this page excluding J-pull option will accept woodgrain laminate where laminate is currently an option. List price for woodgrain laminate options will be current published laminate list price plus 10%.	
<b>118</b> Finish, Bright White	Workwalls do not come with lock included. Keying instructions must accompany all orders, refer to page 523. Random locks are factory installed. Key-alike are field installed using the KnollKey order form.	
<b>( )</b> Fabric selection	Products on this page, shipped knocked-down.  Applicable finishes are listed on page 5 and 6.	

dimensions noted nominal

# Overhead, 28<sup>3</sup>/<sub>8</sub>" planning Workwalls

description	d	h	w	overall height	pattern no.	L	V1	V2	V3
Workwall, (for "desk height") 19"h storage (hinged door)	15"	19"	60"	75"	<b>ROWH60S0DH</b> ( ) ( ) ( ) ( )	\$2,674.	\$2,787.	\$3,255.	\$4,395.
	15"	19"	72"	75"	<b>ROWH72S0DH</b> ( ) ( ) ( ) ( )	3,427.	3,569.	4,161.	5,617.
	15"	19"	90"	75"	<b>ROWH90S0DH</b> ( ) ( ) ( ) ( )	3,805.	3,973.	4,649.	6,277.
	15"	19"	96"	75"	<b>ROWH96S0DH</b> ( ) ( ) ( ) ( )	3,911.	4,084.	4,786.	6,461.
	20"	19"	60"	75"	<b>ROWH60S1DH</b> ( ) ( ) ( ) ( )	2,872.	2,992.	3,491.	4,713.
	20"	19"	72"	75"	<b>ROWH72S1DH</b> ( ) ( ) ( ) ( )	3,672.	3,823.	4,451.	6,009.
	20"	19"	90"	75"	<b>ROWH90S1DH</b> ( ) ( ) ( ) ( )	4,217.	4,397.	5,136.	6,933.
	20"	19"	96"	75"	<b>ROWH96S1DH</b> ( ) ( ) ( ) ( )	4,321.	4,508.	5,273.	7,118.

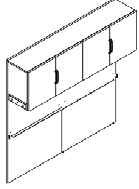

60" w and 72" w units have four hinged doors, two lock cores required  
90" w and 96" w units have 6 hinged doors, three lock cores required

Order Code	Specification Information	Application Notes
Example: <b>ROWO60S0DHL118</b> ( )	<i>To order please specify pattern number including:</i>	<p>Products on this page are engineered to align with 75" h cabinets on page 0. Be sure storage dimension options and drilling options correspond accordingly. For storage options below the worksurface, specify 28<sup>3</sup>/<sub>8</sub>" h products on page 0 ; <b>do not mix products from 26<sup>1</sup>/<sub>2</sub>" h (standard height) planning model with 28<sup>3</sup>/<sub>8</sub>" h (desk height) planning model in any one configuration.</b></p> <p>75" nominal height - actual height 75.125"</p> <p>If attaching workwall to 75" cabinet(s) for support, please provide drawing of layout with order.</p> <p>Tackboard included with workwall; fabric applied railroaded.</p> <p>Tasklights to be ordered separately</p>
<b>R</b> Reff	1. <i>Configuration option (embedded in pattern number)</i> O = Open H = Hinged doors	
<b>O</b> Overhead	2. <i>Storage option (embedded in pattern number)</i> S0 = 19" h x 15" d S1 = 19" h x 20" d T0 = 23" h x 15" d T1 = 23" h x 20" d	
<b>W</b> Workwall	3. <i>Finish type</i> L = laminate 1 = V1 2 = V2 3 = V3	
<b>O</b> Open	4. <i>Pull option</i> (Optional hinged door configurations only) D = metal D-pull (finish optional) J = routed J-pull (finish matches case) C = nickel finish C-pull (nickel finish only) S = S-pull (stainless steel finish only)	
<b>60</b> 60" wide	5. <i>Lock option</i> (Optional hinged door configurations only) L = drilled to accept lock N = no drilling	
<b>S</b> 19" storage height	6. <i>Finish</i>	
<b>0</b> 15" storage depth	7. <i>Optional pull finish, where applicable</i>	
<b>DH</b> desk height, 75" height overall	8. <i>Fabric for tackboard</i>	
<b>L</b> Finish type, laminate	Product on this page excluding J-pull option will accept woodgrain laminate where laminate is currently an option. List price for woodgrain laminate options will be current published laminate list price plus 10%.	
<b>118</b> Finish, Bright White	Workwalls do not come with lock included. Keying instructions must accompany all orders, refer to page 523. Random locks are factory installed. Key-alike are field installed using the KnollKey order form.	
<b>( )</b> Fabric selection	Products on this page, shipped knocked-down.  Applicable finishes are listed on page 5 and 6.	

dimensions noted nominal

# Overhead, 28<sup>3</sup>/<sub>8</sub>" planning Workwalls

description	d	h	w	overall height	pattern no.	L	V1	V2	V3
Workwall, (for "desk height") 23" h storage (hinged door)	15"	23"	60"	75"	<b>ROWH60T0DH</b> ( ) ( ) ( ) ( )	\$2,900.	\$3,020.	\$3,527.	\$4,762.
	15"	23"	72"	75"	<b>ROWH72T0DH</b> ( ) ( ) ( ) ( )	3,879.	4,036.	4,697.	6,342.
	15"	23"	90"	75"	<b>ROWH90T0DH</b> ( ) ( ) ( ) ( )	4,377.	4,562.	5,327.	7,191.
	15"	23"	96"	75"	<b>ROWH96T0DH</b> ( ) ( ) ( ) ( )	4,482.	4,675.	5,463.	7,377.
	20"	23"	60"	75"	<b>ROWH60T1DH</b> ( ) ( ) ( ) ( )	3,099.	3,226.	3,757.	5,073.
	20"	23"	72"	75"	<b>ROWH72T1DH</b> ( ) ( ) ( ) ( )	4,264.	4,437.	5,156.	6,961.
	20"	23"	90"	75"	<b>ROWH90T1DH</b> ( ) ( ) ( ) ( )	4,647.	4,840.	5,647.	7,623.
	20"	23"	96"	75"	<b>ROWH96T1DH</b> ( ) ( ) ( ) ( )	4,748.	4,950.	5,781.	7,804.

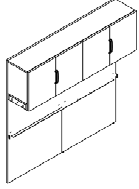

60" w and 72" w units have four hinged doors, two lock cores required  
90" w and 96" w units have 6 hinged doors, three lock cores required

Order Code	Specification Information	Application Notes
Example: <b>ROWO60S0DHL118</b> ( ) <b>R</b> Reff <b>O</b> Overhead <b>W</b> Workwall <b>O</b> Open <b>60</b> 60" wide <b>S</b> 19" storage height <b>0</b> 15" storage depth <b>DH</b> desk height, 75" height overall <b>L</b> Finish type, laminate <b>118</b> Finish, Bright White <b>( )</b> Fabric selection	To order please specify pattern number including: 1. Configuration option (embedded in pattern number) O = Open H = Hinged doors 2. Storage option (embedded in pattern number) S0 = 19" h x 15" d S1 = 19" h x 20" d T0 = 23" h x 15" d T1 = 23" h x 20" d 3. Finish type L = laminate 1 = V1 2 = V2 3 = V3 4. Pull option (Optional hinged door configurations only) D = metal D-pull (finish optional) J = routed J-pull (finish matches case) C = nickel finish C-pull (nickel finish only) S = S-pull (stainless steel finish only)	Products on this page are engineered to align with 75" h cabinets on page 0. Be sure storage dimension options and drilling options correspond accordingly. For storage options below the worksurface, specify 28 <sup>3</sup> / <sub>8</sub> " h products on page 0 ; <b>do not mix products from 26<sup>1</sup>/<sub>2</sub>" h (standard height) planning model with 28<sup>3</sup>/<sub>8</sub>" h (desk height) planning model in any one configuration.</b>  75" nominal height - actual height 75.125"  If attaching workwall to 75" cabinet(s) for support, please provide drawing of layout with order.  Tackboard included with workwall; fabric applied railroaded.  Tasklights to be ordered separately  Products on this page excluding J-pull option will accept woodgrain laminate where laminate is currently an option. List price for woodgrain laminate options will be current published laminate list price plus 10%.  Workwalls do not come with lock included. Keying instructions must accompany all orders, refer to page 523. Random locks are factory installed. Key-alike are field installed using the KnollKey order form.  Products on this page, shipped knocked-down.  Applicable finishes are listed on page 5 and 6.

dimensions noted nominal

# Overhead, 28<sup>3</sup>/<sub>8</sub>" planning Shoulders

description	d	h	w	overall height	pattern no.	L	V1	V2	V3
Workwall support end panels for 75"h x 20"d workwall cabinets	15"	19"		75"	<b>RWEA7520(L/R) ( ) ( )</b>	\$386.	\$399.	\$456.	\$618.
	15"	23"		75"	<b>RWEB7520(L/R) ( ) ( )</b>	386.	399.	456.	618.
	20"	19"		75"	<b>RWEC7520(L/R) ( ) ( )</b>	386.	399.	456.	618.
	20"	23"		75"	<b>RWED7520(L/R) ( ) ( )</b>	386.	399.	456.	618.



depth and width indicate drilled to support workwall with corresponding storage dimensions

Workwall support end panels for 75"h x 24"d workwall cabinets	15"	19"		75"	<b>RWEA7524(L/R) ( ) ( )</b>	419.	436.	500.	675.
	15"	23"		75"	<b>RWEB7524(L/R) ( ) ( )</b>	419.	436.	500.	675.
	20"	19"		75"	<b>RWEC7524(L/R) ( ) ( )</b>	419.	436.	500.	675.
	20"	23"		75"	<b>RWED7524(L/R) ( ) ( )</b>	419.	436.	500.	675.



depth and width indicate drilled to support workwall with corresponding storage dimensions

Overhead shoulder	15"	68"	2"	68"	<b>ROSSH681 ( ) ( )</b>	368.	379.	435.	587.
	15"	82"	2"	82"	<b>ROSDH821 ( ) ( )</b>	400.	415.	476.	643.



\*To be used with Progressive overheads

Order Code	Specification Information	Application Notes
Example: <b>ROWO60S0DHL118 ( )</b>	<i>To order please specify pattern number including:</i>	<p>Products on this page are engineered to align with 75"h cabinets on page 0. Be sure storage dimension options and drilling options correspond accordingly. For storage options below the worksurface, specify 28<sup>3</sup>/<sub>8</sub>" products on page 0 ; <b>do not mix products from 26<sup>1</sup>/<sub>2</sub>" (standard height) planning model with 28<sup>3</sup>/<sub>8</sub>" (desk height) planning model in any one configuration.</b></p> <p>75" nominal height - actual height 75.125"</p> <p>If attaching workwall to 75" cabinet(s) for support, please provide drawing of layout with order.</p> <p>Tackboard included with workwall; fabric applied railroaded.</p> <p>Tasklights to be ordered separately</p>
<b>R</b> Reff	1. <i>Configuration option (embedded in pattern number)</i> O = Open H = Hinged doors	
<b>O</b> Overhead	2. <i>Storage option (embedded in pattern number)</i> S0 = 19"h x 15"d S1 = 19"h x 20"d T0 = 23"h x 15"d T1 = 23"h x 20"d	
<b>W</b> Workwall	3. <i>Finish type</i> L = laminate 1 = V1 2 = V2 3 = V3	
<b>O</b> Open	4. <i>Pull option</i> (Optional hinged door configurations only) D = metal D-pull (finish optional) J = routed J-pull (finish matches case) C = nickel finish C-pull (nickel finish only) S = S-pull (stainless steel finish only)	
<b>60</b> 60" wide	5. <i>Lock option</i> (Optional hinged door configurations only) L = drilled to accept lock N = no drilling	
<b>S</b> 19" storage height	6. <i>Finish</i>	
<b>0</b> 15" storage depth	7. <i>Optional pull finish, where applicable</i>	
<b>DH</b> desk height, 75" height overall	8. <i>Fabric for tackboard</i>	
<b>L</b> Finish type, laminate	Product on this page excluding J-pull option will accept woodgrain laminate where laminate is currently an option. List price for woodgrain laminate options will be current published laminate list price plus 10%.	
<b>118</b> Finish, Bright White	Workwalls do not come with lock included. Keying instructions must accompany all orders, refer to page 523. Random locks are factory installed. Key-alike are field installed using the KnollKey order form.	
<b>( )</b> Fabric selection	Products on this page, shipped knocked-down.  Applicable finishes are listed on page 5 and 6.	

dimensions noted nominal

# Overhead, 28<sup>3</sup>/<sub>8</sub>" planning Use with 1<sup>1</sup>/<sub>4</sub>" worksurfaces Overdesk unit

Reff Profiles

description	d	w	h	pattern no.	L	V1	V2	V3
Overdesk unit (for 1 <sup>1</sup> / <sub>4</sub> " worksurface at "desk height") O=Open	15"	60"	45 <sup>1</sup> / <sub>2</sub> "	ROAO60T0DH ( ) ( ) ( ) ( ) ( )	\$1,732.	\$2,178.	\$2,566.	\$3,466.
	15"	72"	45 <sup>1</sup> / <sub>2</sub> "	ROAO72T0DH ( ) ( ) ( ) ( ) ( )	2,207.	2,775.	3,256.	4,396.
	15"	90"	45 <sup>1</sup> / <sub>2</sub> "	ROAO90T0DH ( ) ( ) ( ) ( ) ( )	2,414.	3,047.	3,602.	4,863.
	15"	96"	45 <sup>1</sup> / <sub>2</sub> "	ROAO96T0DH ( ) ( ) ( ) ( ) ( )	2,508.	3,165.	3,744.	5,055.
	20"	60"	45 <sup>1</sup> / <sub>2</sub> "	ROAO60T1DH ( ) ( ) ( ) ( ) ( )	1,838.	2,310.	2,718.	3,668.
	20"	72"	45 <sup>1</sup> / <sub>2</sub> "	ROAO72T1DH ( ) ( ) ( ) ( ) ( )	2,338.	2,938.	3,445.	4,649.
	20"	90"	45 <sup>1</sup> / <sub>2</sub> "	ROAO90T1DH ( ) ( ) ( ) ( ) ( )	2,563.	3,233.	3,812.	5,145.
	20"	96"	45 <sup>1</sup> / <sub>2</sub> "	ROAO96T1DH ( ) ( ) ( ) ( ) ( )	2,664.	3,361.	3,968.	5,357.
Overdesk unit (for 1 <sup>1</sup> / <sub>4</sub> " worksurface at "desk height") H=Hinged Door	15"	60"	45 <sup>1</sup> / <sub>2</sub> "	ROAH60T0DH ( ) ( ) ( ) ( ) ( )	2,615.	3,285.	3,836.	5,179.
	15"	72"	45 <sup>1</sup> / <sub>2</sub> "	ROAH72T0DH ( ) ( ) ( ) ( ) ( )	3,317.	4,155.	4,847.	6,544.
	15"	90"	45 <sup>1</sup> / <sub>2</sub> "	ROAH90T0DH ( ) ( ) ( ) ( ) ( )	3,687.	4,624.	5,416.	7,312.
	15"	96"	45 <sup>1</sup> / <sub>2</sub> "	ROAH96T0DH ( ) ( ) ( ) ( ) ( )	3,841.	4,822.	5,652.	7,630.
	20"	60"	45 <sup>1</sup> / <sub>2</sub> "	ROAH60T1DH ( ) ( ) ( ) ( ) ( )	2,770.	3,473.	4,051.	5,471.
	20"	72"	45 <sup>1</sup> / <sub>2</sub> "	ROAH72T1DH ( ) ( ) ( ) ( ) ( )	3,502.	4,386.	5,110.	6,899.
	20"	90"	45 <sup>1</sup> / <sub>2</sub> "	ROAH90T1DH ( ) ( ) ( ) ( ) ( )	3,898.	4,891.	5,721.	7,724.
	20"	96"	45 <sup>1</sup> / <sub>2</sub> "	ROAH96T1DH ( ) ( ) ( ) ( ) ( )	4,066.	5,101.	5,975.	8,064.

60" w and 72" w hinged door units have four hinged doors, two lock cores required  
90" w and 96" w hinged door units have six hinged doors, three lock cores required

Order Code	Specification Information	Application Notes
Example: <b>ROAO60T0DHLBF118( )</b>	<i>To order please specify pattern number including:</i>	<p>Products on this page are engineered to align with 75" h cabinets on page 0. Be sure storage dimension options and drilling options correspond accordingly. For storage options below the worksurface, specify 28<sup>3</sup>/<sub>8</sub>" h products on page 0 ; <b>do not mix products from 26<sup>1</sup>/<sub>2</sub>" h (standard height) planning model with 28<sup>3</sup>/<sub>8</sub>" h (desk height) planning model in any one configuration.</b></p> <p>Overdesk unit will achieve 75" nominal height - actual height 75.125", when used with correct thickness of top.</p> <p>Clearance below overhead storage to top of worksurface is approximately 23<sup>1</sup>/<sub>8</sub>" h.</p> <p>Applicable finishes are listed on page 5 and 6.</p>
<b>R</b> Reff	6. <i>Tasklight cord escape</i> BF = back feed FF = front feed	
<b>O</b> Overhead	7. <i>Finish</i>	
<b>A</b> For mounting on 1 <sup>1</sup> / <sub>4</sub> " thick top	8. <i>Optional pull finish, where applicable</i>	
<b>O</b> Open	9. <i>Fabric for tackboard</i>	
<b>60</b> 60" wide	<b>Woodgrain Laminate is not available on any flip door units.</b>	
<b>T</b> 23" h storage	Overdesk units do not come with lock included. Keying instructions must accompany all orders, refer to page 523. Random locks are factory installed. Key-alike are field installed using the KnollKey order form.	
<b>0</b> 15" d storage		
<b>DH</b> desk height, 75" height overall		
<b>L</b> Finish type, laminate		
<b>BF</b> Cord escape, back feed		
<b>118</b> Finish, Bright White		
<b>( )</b> Fabric selection		
<i>dimensions noted nominal</i>	<ol style="list-style-type: none"> <li><i>Configuration option (embedded in pattern number)</i> O = Open H = Hinged doors F = Flip doors</li> <li><i>Storage option (embedded in pattern number)</i> S0 = 19" h x 15" d S1 = 19" h x 20" d T0 = 23" h x 15" d T1 = 23" h x 20" d</li> <li><i>Finish type</i> L = laminate 1 = V1 2 = V2 3 = V3</li> <li><i>Pull option</i> (Optional hinged door configurations only) D = metal D-pull (finish optional) J = routed J-pull (finish matches case) C = nickel finish C-pull (nickel finish only) S = S-pull (stainless steel finish only)</li> <li><i>Lock option</i> (Optional hinged door configurations only) L = drilled to accept lock N = no drilling</li> </ol> <p>Products on this page shipped knocked-down.</p> <p>Tasklights not included.</p> <p>Tackboard included, fabric orientation applied railroaded.</p> <p>Wire manager included and mounts adjacent to tackboard. Specify color.</p> <p>Include grommet (black only) in back panel for tasklight cord. If used in open plan areas, specify "no grommet"</p>	

# Overhead, 28<sup>3</sup>/<sub>8</sub>" planning

## Use with 1<sup>1</sup>/<sub>4</sub>" worksurfaces

### Overdesk unit

description	d	w	h	pattern no.	L	V1	V2	V3
Overdesk unit	15"	60"	45 <sup>1</sup> / <sub>2</sub> "	ROAF60S0DH ( ) ( ) ( ) ( )	\$2,239.	\$3,051.	\$3,569.	\$4,817.
(for 1 <sup>1</sup> / <sub>4</sub> " worksurface at "desk height")	15"	72"	45 <sup>1</sup> / <sub>2</sub> "	ROAF72S0DH ( ) ( ) ( ) ( )	2,659.	3,868.	4,515.	6,095.
F=Flip door	15"	84"	45 <sup>1</sup> / <sub>2</sub> "	ROAF84S0DH ( ) ( ) ( ) ( )	3,446.	4,408.	5,156.	6,961.
	15"	96"	45 <sup>1</sup> / <sub>2</sub> "	ROAF96S0DH ( ) ( ) ( ) ( )	3,530.	4,527.	5,312.	7,172.
	20"	60"	45 <sup>1</sup> / <sub>2</sub> "	ROAF60S1DH ( ) ( ) ( ) ( )	2,373.	3,228.	3,774.	5,094.
	20"	72"	45 <sup>1</sup> / <sub>2</sub> "	ROAF72S1DH ( ) ( ) ( ) ( )	2,811.	4,083.	4,764.	6,430.
	20"	84"	45 <sup>1</sup> / <sub>2</sub> "	ROAF84S1DH ( ) ( ) ( ) ( )	3,643.	4,662.	5,445.	7,351.
	20"	96"	45 <sup>1</sup> / <sub>2</sub> "	ROAF96S1DH ( ) ( ) ( ) ( )	3,738.	4,796.	5,620.	7,587.

all flip door units have two flip doors, two lock cores required  
 J-pull only, C, D and S pulls are not optional for flip door units

Order Code	Specification Information	Application Notes
Example: <b>ROAO60T0DHLBF118( )</b>	<i>To order please specify pattern number including:</i>	<p>Products on this page are engineered to align with 75" h cabinets on page 0. Be sure storage dimension options and drilling options correspond accordingly. For storage options below the worksurface, specify 28<sup>3</sup>/<sub>8</sub>" h products on page 0 ; <b>do not mix products from 26<sup>1</sup>/<sub>2</sub>" h (standard height) planning model with 28<sup>3</sup>/<sub>8</sub>" h (desk height) planning model in any one configuration.</b></p> <p>Overdesk unit will achieve 75" nominal height - actual height 75.125", when used with correct thickness of top.</p> <p>Clearance below overhead storage to top of worksurface is approximately 23<sup>1</sup>/<sub>8</sub>" h.</p> <p>Applicable finishes are listed on page 5 and 6.</p>
<b>R</b> Reff	1. <i>Configuration option (embedded in pattern number)</i> O = Open H = Hinged doors F = Flip doors	
<b>O</b> Overhead	2. <i>Storage option (embedded in pattern number)</i> S0 = 19" h x 15" d S1 = 19" h x 20" d T0 = 23" h x 15" d T1 = 23" h x 20" d	
<b>A</b> For mounting on 1 <sup>1</sup> / <sub>4</sub> " thick top	3. <i>Finish type</i> L = laminate 1 = V1 2 = V2 3 = V3	
<b>O</b> Open	4. <i>Pull option</i> (Optional hinged door configurations only) D = metal D-pull (finish optional) J = routed J-pull (finish matches case) C = nickel finish C-pull (nickel finish only) S = S-pull (stainless steel finish only)	
<b>60</b> 60" wide	5. <i>Lock option</i> (Optional hinged door configurations only) L = drilled to accept lock N = no drilling	
<b>T</b> 23" h storage	6. <i>Tasklight cord escape</i> BF = back feed FF = front feed	
<b>0</b> 15" d storage	7. <i>Finish</i>	
<b>DH</b> desk height, 75" height overall	8. <i>Optional pull finish, where applicable</i>	
<b>L</b> Finish type, laminate	9. <i>Fabric for tackboard</i>	
<b>BF</b> Cord escape, back feed	<b>Woodgrain Laminate is not available on any flip door units.</b>	
<b>118</b> Finish, Bright White	Overdesk units do not come with lock included. Keying instructions must accompany all orders, refer to page 523. Random locks are factory installed. Key-alike are field installed using the KnollKey order form.	
<b>( )</b> Fabric selection	Products on this page shipped knocked-down.  Tasklights not included.  Tackboard included, fabric orientation applied railroaded.  Wire manager included and mounts adjacent to tackboard. Specify color.  Include grommet (black only) in back panel for tasklight cord. If used in open plan areas, specify "no grommet"	

dimensions noted nominal

Overhead storage

# Overhead, 28<sup>3</sup>/<sub>8</sub>" planning

## Use with 1<sup>3</sup>/<sub>4</sub>" worksurfaces

### Overdesk unit

description	d	w	h	pattern no.	L	V1	V2	V3
Overdesk unit	15"	60"	45"	<b>ROBH60T0DH</b> ( ) ( ) ( ) ( )	\$2,650.	\$3,320.	\$3,879.	\$5,236.
(for 1 <sup>3</sup> / <sub>4</sub> " worksurface at "desk height")	15"	72"	45"	<b>ROBH72T0DH</b> ( ) ( ) ( ) ( )	3,355.	4,203.	4,902.	6,617.
H=Hinged Door	15"	90"	45"	<b>ROBH90T0DH</b> ( ) ( ) ( ) ( )	3,729.	4,678.	5,475.	7,390.
	15"	96"	45"	<b>ROBH96T0DH</b> ( ) ( ) ( ) ( )	3,887.	4,881.	5,717.	7,718.
	20"	60"	45"	<b>ROBH60T1DH</b> ( ) ( ) ( ) ( )	2,802.	3,507.	4,095.	5,529.
	20"	72"	45"	<b>ROBH72T1DH</b> ( ) ( ) ( ) ( )	3,541.	4,434.	5,166.	6,974.
	20"	90"	45"	<b>ROBH90T1DH</b> ( ) ( ) ( ) ( )	3,945.	4,946.	5,786.	7,812.
	20"	96"	45"	<b>ROBH96T1DH</b> ( ) ( ) ( ) ( )	4,111.	5,161.	6,043.	8,157.

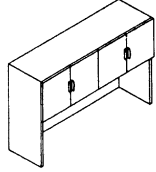

60"w and 72"w hinged door units have four hinged doors, two lock cores required  
 90"w and 96"w hinged door units have six hinged doors, three lock cores required

Overdesk unit	15"	60"	45"	<b>ROBO60T0DH</b> ( ) ( ) ( ) ( )	1,750.	2,206.	2,595.	3,502.
(for 1 <sup>3</sup> / <sub>4</sub> " worksurface at "desk height")	15"	72"	45"	<b>ROBO72T0DH</b> ( ) ( ) ( ) ( )	2,217.	2,808.	3,295.	4,448.
O=Open	15"	90"	45"	<b>ROBO90T0DH</b> ( ) ( ) ( ) ( )	2,445.	3,082.	3,643.	4,918.
	15"	96"	45"	<b>ROBO96T0DH</b> ( ) ( ) ( ) ( )	2,536.	3,203.	3,791.	5,117.
	20"	60"	45"	<b>ROBO60T1DH</b> ( ) ( ) ( ) ( )	1,857.	2,337.	2,750.	3,712.
	20"	72"	45"	<b>ROBO72T1DH</b> ( ) ( ) ( ) ( )	2,363.	2,968.	3,482.	4,702.
	20"	90"	45"	<b>ROBO90T1DH</b> ( ) ( ) ( ) ( )	2,541.	3,206.	3,794.	5,122.
	20"	96"	45"	<b>ROBO96T1DH</b> ( ) ( ) ( ) ( )	2,599.	3,272.	3,859.	5,209.

Order Code	Specification Information	Application Notes
Example: <b>ROBO60T0DHLBF118( )</b>	<i>To order please specify pattern number including:</i>	Products on this page are engineered to align with 75" h cabinets on page 0. Be sure storage dimension options and drilling options correspond accordingly. For storage options below the worksurface, specify 28 <sup>3</sup> / <sub>8</sub> " h products on page 0 ; <b>do not mix products from 26<sup>1</sup>/<sub>2</sub>" h (standard height) planning model with 28<sup>3</sup>/<sub>8</sub>" h (desk height) planning model in any one configuration.</b>
<b>R</b> Reff	6. <i>Tasklight cord escape</i> BF = back feed FF = front feed	
<b>O</b> Overhead	1. <i>Configuration option (embedded in pattern number)</i> O = Open H = Hinged doors F = Flip doors	Overdesk units do not come with lock included. Keying instructions must accompany all orders, refer to page 523. Random locks are factory installed. Key-alike are field installed using the KnollKey order form.
<b>B</b> For mounting on 1 <sup>3</sup> / <sub>4</sub> " thick top	2. <i>Storage option (embedded in pattern number)</i> S0 = 19" h x 15" d S1 = 19" h x 20" d T0 = 23" h x 15" d T1 = 23" h x 20" d	
<b>O</b> Open	3. <i>Finish type</i> L = laminate 1 = V1 2 = V2 3 = V3	Products on this page shipped knocked-down.
<b>60</b> 60" wide	4. <i>Pull option</i> (Optional hinged door configurations only) D = metal D-pull (finish optional) J = routed J-pull (finish matches case) C = nickel finish C-pull (nickel finish only) S = S-pull (stainless steel finish only)	Tasklights not included.  Tackboard included, fabric orientation applied railroaded.  Wire manager included and mounts adjacent to tackboard. Specify color.
<b>T</b> 23" h storage	5. <i>Lock option</i> (Optional hinged door configurations only) L = drilled to accept lock N = no drilling	Overdesk unit will achieve 75" nominal height - actual height 75.125", when used with correct thickness of top.  Clearance below overhead storage to top of worksurface is approximately 22 <sup>3</sup> / <sub>8</sub> " h.
<b>0</b> 15" d storage		Applicable finishes are listed on page 5 and 6.
<b>DH</b> desk height, 75" height overall		
<b>L</b> Finish type, laminate		
<b>BF</b> Cord escape, back feed		
<b>118</b> Finish, Bright White		
<b>( )</b> Fabric selection		

dimensions noted nominal



# Overhead, 28<sup>3</sup>/<sub>8</sub>" planning

## Use with 1<sup>3</sup>/<sub>4</sub>" worksurfaces

### Overdesk unit

description	d	w	h	pattern no.	L	V1	V2	V3
Overdesk unit	15"	60"	45"	<b>ROBF60S0DH</b> ( ) ( ) ( ) ( )	\$2,265.	\$3,088.	\$3,609.	\$4,873.
(for 1 <sup>3</sup> / <sub>4</sub> " worksurface	15"	72"	45"	<b>ROBF72S0DH</b> ( ) ( ) ( ) ( )	2,689.	3,912.	4,565.	6,163.
at "desk height")	15"	84"	45"	<b>ROBF84S0DH</b> ( ) ( ) ( ) ( )	3,483.	4,454.	5,210.	7,034.
F=Flip door	15"	96"	45"	<b>ROBF96S0DH</b> ( ) ( ) ( ) ( )	3,571.	4,583.	5,376.	7,259.
	20"	60"	45"	<b>ROBF60S1DH</b> ( ) ( ) ( ) ( )	2,399.	3,265.	3,815.	5,150.
	20"	72"	45"	<b>ROBF72S1DH</b> ( ) ( ) ( ) ( )	2,844.	4,132.	4,816.	6,502.
	20"	84"	45"	<b>ROBF84S1DH</b> ( ) ( ) ( ) ( )	3,688.	4,718.	5,511.	7,441.
	20"	96"	45"	<b>ROBF96S1DH</b> ( ) ( ) ( ) ( )	3,784.	4,848.	5,679.	7,665.

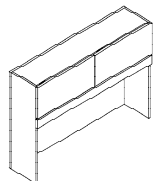

all flip door units have two flip doors, two lock cores required  
J-pull only; C, D and S pulls are not optional for flip door units

Order Code	Specification Information	Application Notes
Example: <b>ROBO60T0DHLBF118( )</b>	<i>To order please specify pattern number including:</i>	<p>Products on this page are engineered to align with 75" h cabinets on page 0. Be sure storage dimension options and drilling options correspond accordingly. For storage options below the worksurface, specify 28<sup>3</sup>/<sub>8</sub>" h products on page 0 ; <b>do not mix products from 26<sup>1</sup>/<sub>2</sub>" h (standard height) planning model with 28<sup>3</sup>/<sub>8</sub>" h (desk height) planning model in any one configuration.</b></p> <p>Overdesk unit will achieve 75" nominal height - actual height 75.125", when used with correct thickness of top.</p> <p>Clearance below overhead storage to top of worksurface is approximately 22<sup>3</sup>/<sub>8</sub>" h.</p> <p>Applicable finishes are listed on page 5 and 6.</p>
<b>R</b> Reff	6. <i>Tasklight cord escape</i> BF = back feed FF = front feed	
<b>O</b> Overhead	7. <i>Finish</i>	
<b>B</b> For mounting on 1 <sup>3</sup> / <sub>4</sub> " thick top	8. <i>Optional pull finish, where applicable</i>	
<b>O</b> Open	9. <i>Fabric for tackboard</i>	
<b>60</b> 60" wide	Overdesk units do not come with lock included. Keying instructions must accompany all orders, refer to page 523. Random locks are factory installed. Key-alike are field installed using the KnollKey order form.	
<b>T</b> 23" h storage	Products on this page shipped knocked-down.	
<b>0</b> 15" d storage	Tasklights not included.	
<b>DH</b> desk height, 75" height overall	Tackboard included, fabric orientation applied railroaded.	
<b>L</b> Finish type, laminate	Wire manager included and mounts adjacent to tackboard. Specify color.	
<b>BF</b> Cord escape, back feed	Include grommet (black only) in back panel for tasklight cord. If used in open plan areas, specify "no grommet".	
<b>118</b> Finish, Bright White	Woodgrain Laminate is not available on any flip door units.	
<b>( )</b> Fabric selection		

dimensions noted nominal

Overhead storage

# Overhead, 28<sup>3</sup>/<sub>8</sub>" planning

## Single high

### Wall hung with and without Center Gables

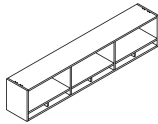
description	w	d	h	locks req'd	doors	pattern no.	L	V1	V2	V3
Wall-hung overhead cabinet open /cubby with center gable 	30"	15"	20"			<b>ROMCGSHP301</b> ( ) ( )	\$1,178.	\$1,649.	\$1,896.	\$2,465.
	36"	15"	20"			<b>ROMCGSHP361</b> ( ) ( )	1,215.	1,701.	1,956.	2,543.
	42"	15"	20"			<b>ROMCGSHP421</b> ( ) ( )	1,320.	1,848.	2,126.	2,763.
	48"	15"	20"			<b>ROMCGSHP481</b> ( ) ( )	1,373.	1,922.	2,210.	2,873.
	54"	15"	20"			<b>ROMCGSHP541</b> ( ) ( )	1,610.	2,254.	2,593.	3,370.
	60"	15"	20"			<b>ROMCGSHP601</b> ( ) ( )	1,868.	2,616.	3,008.	3,910.
	66"	15"	20"			<b>ROMCGSHP661</b> ( ) ( )	1,903.	2,664.	3,063.	3,983.
	72"	15"	20"			<b>ROMCGSHP721</b> ( ) ( )	1,940.	2,716.	3,124.	4,061.
	78"	15"	20"			<b>ROMCGSHP781</b> ( ) ( )	2,037.	2,852.	3,280.	4,264.
	84"	15"	20"			<b>ROMCGSHP841</b> ( ) ( )	2,369.	3,317.	3,814.	4,958.
	90"	15"	20"			<b>ROMCGSHP901</b> ( ) ( )	2,409.	3,373.	3,879.	5,042.
96"	15"	20"			<b>ROMCGSHP961</b> ( ) ( )	2,447.	3,426.	3,940.	5,122.	

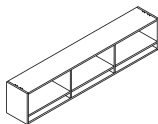
Wall-hung overhead cabinet open /cubby without center gable 	30"	15"	20"			<b>ROMOCSHP301</b> ( ) ( )	1,060.	1,484.	1,706.	2,219.
	36"	15"	20"			<b>ROMOCSHP361</b> ( ) ( )	1,094.	1,531.	1,760.	2,289.
	42"	15"	20"			<b>ROMOCSHP421</b> ( ) ( )	1,188.	1,663.	1,913.	2,487.
	48"	15"	20"			<b>ROMOCSHP481</b> ( ) ( )	1,236.	1,730.	1,989.	2,586.
	54"	15"	20"			<b>ROMOCSHP541</b> ( ) ( )	1,449.	2,029.	2,334.	3,033.
	60"	15"	20"			<b>ROMOCSHP601</b> ( ) ( )	1,681.	2,354.	2,707.	3,519.
	66"	15"	20"			<b>ROMOCSHP661</b> ( ) ( )	1,713.	2,398.	2,757.	3,585.
	72"	15"	20"			<b>ROMOCSHP721</b> ( ) ( )	1,746.	2,444.	2,812.	3,655.
	78"	15"	20"			<b>ROMOCSHP781</b> ( ) ( )	1,833.	2,567.	2,952.	3,838.
	84"	15"	20"			<b>ROMOCSHP841</b> ( ) ( )	2,132.	2,985.	3,433.	4,462.
	90"	15"	20"			<b>ROMOCSHP901</b> ( ) ( )	2,168.	3,036.	3,491.	4,538.
96"	15"	20"			<b>ROMOCSHP961</b> ( ) ( )	2,202.	3,083.	3,546.	4,610.	

Without center gable

Order Code	Specification Information	Application Notes
Example: <b>ROMCGSHP301</b>	<i>To order please specify:</i>	These products are Glue and Dowel Construction
<b>R</b> Reff	1. Finish type:	Knoll does not assume any responsibility for the installation, attachment or the securing of wall hung units to the wall.
<b>O</b> Overhead	L = Laminate	A certified building contractor should be consulted.
<b>M</b> Wall mount	1 = V1	Please refer to wall mounting information on page 494.
<b>CG</b> Center Gable	2 = V2	
<b>SH</b> Single high	3 = V3	
<b>P</b> Planning	2. Case finish	Tasklights ordered separately
<b>30</b> 30" width		Tack/Task panel order separately
<b>2</b> Case finish type		Wall hung cabinets come with wall hung cleates
<b>V316</b> V2 finish		Unfinished back

dimensions noted nominal

Single high

Wall hung with doors

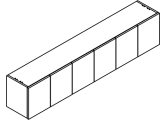
description	w	d	h	pattern no.	L/L	L/V1	L/V2	L/V3	V1/V1	V2/V2	V3/V3	
Wall-hung overhead cabinet hinge door, cubby concealed 	30"	15"	20"	ROMHSHP301	(X)(X)(X)(X)(X)	\$1,817.	\$1,998.	\$2,089.	\$2,180.	\$2,543.	\$2,925.	\$3,802.
	36"	15"	20"	ROMHSHP361	(X)(X)(X)(X)(X)	1,864.	2,050.	2,143.	2,236.	2,609.	3,000.	3,901.
	42"	15"	20"	ROMHSHP421	(X)(X)(X)(X)(X)	2,392.	2,631.	2,751.	2,870.	3,349.	3,851.	5,006.
	48"	15"	20"	ROMHSHP481	(X)(X)(X)(X)(X)	2,455.	2,701.	2,824.	2,946.	3,438.	3,953.	5,139.
	54"	15"	20"	ROMHSHP541	(X)(X)(X)(X)(X)	2,609.	2,870.	3,000.	3,130.	3,652.	4,200.	5,460.
	60"	15"	20"	ROMHSHP601	(X)(X)(X)(X)(X)	2,945.	3,240.	3,387.	3,535.	4,124.	4,742.	6,165.
	66"	15"	20"	ROMHSHP661	(X)(X)(X)(X)(X)	2,994.	3,293.	3,443.	3,593.	4,191.	4,820.	6,266.
	72"	15"	20"	ROMHSHP721	(X)(X)(X)(X)(X)	3,044.	3,349.	3,501.	3,653.	4,262.	4,902.	6,372.
	78"	15"	20"	ROMHSHP781	(X)(X)(X)(X)(X)	3,154.	3,470.	3,627.	3,785.	4,416.	5,078.	6,602.
	84"	15"	20"	ROMHSHP841	(X)(X)(X)(X)(X)	3,972.	4,369.	4,567.	4,766.	5,560.	6,394.	8,312.
90"	15"	20"	ROMHSHP901	(X)(X)(X)(X)(X)	4,020.	4,422.	4,623.	4,824.	5,628.	6,473.	8,414.	
96"	15"	20"	ROMHSHP961	(X)(X)(X)(X)(X)	4,073.	4,480.	4,684.	4,888.	5,702.	6,558.	8,525.	

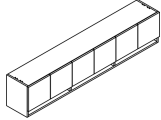
Wall-hung overhead cabinet hinge door, cubby exposed 	30"	15"	20"	ROMCSHP301	(X)(X)(X)(X)(X)	1,723.	1,896.	1,982.	2,068.	2,413.	2,775.	3,607.
	36"	15"	20"	ROMCSHP361	(X)(X)(X)(X)(X)	1,769.	1,946.	2,035.	2,123.	2,477.	2,849.	3,703.
	42"	15"	20"	ROMCSHP421	(X)(X)(X)(X)(X)	2,335.	2,568.	2,685.	2,802.	3,269.	3,759.	4,886.
	48"	15"	20"	ROMCSHP481	(X)(X)(X)(X)(X)	2,427.	2,670.	2,792.	2,913.	3,398.	3,908.	5,081.
	54"	15"	20"	ROMCSHP541	(X)(X)(X)(X)(X)	2,481.	2,729.	2,853.	2,977.	3,473.	3,994.	5,192.
	60"	15"	20"	ROMCSHP601	(X)(X)(X)(X)(X)	2,754.	3,030.	3,167.	3,305.	3,856.	4,434.	5,764.
	66"	15"	20"	ROMCSHP661	(X)(X)(X)(X)(X)	2,797.	3,077.	3,216.	3,356.	3,916.	4,503.	5,854.
	72"	15"	20"	ROMCSHP721	(X)(X)(X)(X)(X)	2,846.	3,130.	3,272.	3,415.	3,984.	4,581.	5,956.
	78"	15"	20"	ROMCSHP781	(X)(X)(X)(X)(X)	2,907.	3,198.	3,343.	3,488.	4,070.	4,680.	6,084.
	84"	15"	20"	ROMCSHP841	(X)(X)(X)(X)(X)	3,671.	4,038.	4,222.	4,405.	5,139.	5,910.	7,683.
90"	15"	20"	ROMCSHP901	(X)(X)(X)(X)(X)	3,734.	4,107.	4,294.	4,480.	5,227.	6,011.	7,815.	
96"	15"	20"	ROMCSHP961	(X)(X)(X)(X)(X)	3,782.	4,160.	4,349.	4,538.	5,295.	6,089.	7,915.	

Order Code	Specification Information	Application Notes
Example: <b>ROMHSHP301</b> <b>(X)(X)(X)(X)(X)</b>	<i>To order please specify:</i>	These products are Glue and Dowel Construction
<b>R</b> Reff	1. Case finish type: L = Laminate 1 = V1 2 = V2 3 = V3	Letter depth is 15" nominal.
<b>O</b> Overhead	2. Front finish type: L = Laminate 1 = V1 2 = V2 3 = V3	Fascias ordered separately
<b>M</b> Wall mount	3. Pull option: B=Blank, no drilling, no touch latch R=Cylinder T=Tab F=Bar	Tasklights not included
<b>H</b> Hinge door	4. Lock option: H= Outline	Tack/Task panel order separately
<b>SH</b> Single High	5. Lock finish: B=Black S=Matte silver	Unfinished backs
<b>P</b> Planning	6. Case finish: V316	Wall hung cabinets come with wall hung cleats
<b>30</b> Width	7. Front finish: V316	
<b>1</b> Depth (letter)	8. Pull finish: Painted or plated	
<b>2</b> Case finish type		
<b>2</b> Front finish type		
<b>H</b> Pull option		
<b>L</b> Lock option		
<b>B</b> Lock finish		
<b>V316</b> Case finish		
<b>V316</b> Front finish		
<b>PU</b> Pull finish		

*dimensions noted nominal*

Overhead, 28<sup>3</sup>/<sub>8</sub>" planning  
 Single high  
 Wall hung with glass doors

description	w	d	h	pattern no.	L	V1	V2	V3
Wall-hung overhead cabinet	30"	15"	20"	<b>ROMGHCSHP301</b> ( ) ( ) ( )	\$2,470.	\$2,692.	\$3,096.	\$4,025.
glass hinge door, cubby exposed	36"	15"	20"	<b>ROMGHCSHP361</b> ( ) ( ) ( )	2,584.	2,817.	3,239.	4,211.
	42"	15"	20"	<b>ROMGHCSHP421</b> ( ) ( ) ( )	3,314.	3,613.	4,155.	5,401.
	48"	15"	20"	<b>ROMGHCSHP481</b> ( ) ( ) ( )	3,426.	3,735.	4,295.	5,583.
	54"	15"	20"	<b>ROMGHCSHP541</b> ( ) ( ) ( )	3,670.	4,000.	4,600.	5,980.
	60"	15"	20"	<b>ROMGHCSHP601</b> ( ) ( ) ( )	4,079.	4,446.	5,113.	6,647.
	66"	15"	20"	<b>ROMGHCSHP661</b> ( ) ( ) ( )	4,202.	4,580.	5,267.	6,847.
	72"	15"	20"	<b>ROMGHCSHP721</b> ( ) ( ) ( )	4,307.	4,694.	5,398.	7,018.
	78"	15"	20"	<b>ROMGHCSHP781</b> ( ) ( ) ( )	4,487.	4,891.	5,625.	7,312.
	84"	15"	20"	<b>ROMGHCSHP841</b> ( ) ( ) ( )	5,530.	6,027.	6,931.	9,011.
	90"	15"	20"	<b>ROMGHCSHP901</b> ( ) ( ) ( )	5,597.	6,100.	7,015.	9,120.
	96"	15"	20"	<b>ROMGHCSHP961</b> ( ) ( ) ( )	5,720.	6,235.	7,171.	9,322.

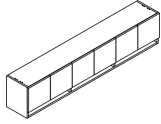

Order Code	Specification Information	Application Notes
Example: <b>ROMGHCSHP301</b> ( ) ( ) ( )	<i>To order please specify:</i>	These products are Glue and Dowel Construction
<b>R</b> Reff	1. Case Finish type: L = Laminate 1 = V1 2 = V2 3 = V3	Letter depth is 15" nominal.
<b>O</b> Overhead	2. Door frame finish: Anodized or painted	Fascias ordered separately
<b>M</b> Wall mount	3. Glass door finish: GL11 GL15 GL18	Tasklights not included
<b>GHC</b> Glass hinge door/ cubby		Tack/Task panel order separately
<b>SH</b> Single High		Unfinished backs
<b>P</b> Planning		Wall hung cabinets come with wall hung cleats
<b>30</b> Width		
<b>1</b> Depth (letter)		
<b>2</b> Case finish type		
<b>V316</b> Case finish		
<b>AU</b> Door frame finish		
<b>GL11</b> Door glass finish		

dimensions noted nominal

Overhead, 28<sup>3</sup>/<sub>8</sub>" planning  
 Single high  
 Wall hung with doors, open

description	w	d	h	pattern no.	L/L	L/V1	L/V2	L/V3	V1/V1	V2/V2	V3/V3
Wall Hung overhead cabinet	60"	15"	20"	ROMHOCSHP601()	\$2,485.	\$2,734.	\$2,858.	\$2,982.	\$3,604.	\$4,144.	\$5,387.
hinge door / open /	66"	15"	20"	ROMHOCSHP661()	2,522.	2,774.	2,901.	3,027.	3,657.	4,206.	5,468.
cubby exposed	72"	15"	20"	ROMHOCSHP721()	2,563.	2,820.	2,948.	3,076.	3,717.	4,274.	5,557.
	78"	15"	20"	ROMHOCSHP781()	2,627.	2,890.	3,022.	3,153.	3,810.	4,381.	5,696.
	84"	15"	20"	ROMHOCSHP841()	3,053.	3,358.	3,510.	3,663.	4,426.	5,090.	6,617.
	90"	15"	20"	ROMHOCSHP901()	3,100.	3,410.	3,565.	3,720.	4,495.	5,169.	6,719.
	96"	15"	20"	ROMHOCSHP961()	3,139.	3,453.	3,610.	3,767.	4,552.	5,234.	6,805.

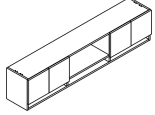

Order Code	Specification Information	Application Notes
Example: <b>ROMHOCSHP601</b> <b>( ) ( ) ( )</b>	<i>To order please specify:</i>	These products are Glue and Dowel Construction
<b>R</b> Reff	1. Case finish type: L = Laminate	Letter depth is 15" nominal.
<b>O</b> Overhead	1 = V1	Fascias ordered separately
<b>M</b> Wall mount	2 = V2	Tasklights not included
<b>HOC</b> Hinge door/Open/Cubby	3 = V3	Tack/Task panel order separately
<b>SH</b> Single high	2. Front finish type: L = Laminate	Unfinished backs
<b>P</b> Planning	1 = V1	Wall hung cabinets come with wall hung cleats
<b>60</b> Width	2 = V2	Doors project below shelf for openings
<b>1</b> Letter depth	3 = V3	No pull options
<b>2</b> Case finish type	3. Lock option: N = no lock drilling	
<b>2</b> Front finish type	L = locking	
<b>L</b> Locked	4. Lock finish: B=Black	
<b>B</b> Black lock	S=Matte silver	
<b>V316</b> Case finish	5. Case finish	
<b>V316</b> Front finish	6. Front finish	

dimensions noted nominal

# Overhead, 28<sup>3</sup>/<sub>8</sub>" planning

*Single high*

*Wall hung with glass doors, open*

*Cubby exposed*

description	w	d	h	pattern no.	L	V1	V2	V3
Wall Hung overhead cabinet	60"	15"	20"	ROMGHOC SHP601()	\$3,050.	\$3,813.	\$4,384.	\$5,700.
glass hinge door / open / cubby exposed	66"	15"	20"	ROMGHOC SHP661()	3,122.	3,903.	4,488.	5,835.
	72"	15"	20"	ROMGHOC SHP721()	3,187.	3,984.	4,581.	5,956.
	78"	15"	20"	ROMGHOC SHP781()	3,276.	4,095.	4,710.	6,123.
	84"	15"	20"	ROMGHOC SHP841()	4,015.	4,818.	5,540.	7,203.
	90"	15"	20"	ROMGHOC SHP901()	4,064.	4,877.	5,609.	7,291.
	96"	15"	20"	ROMGHOC SHP961()	4,149.	4,978.	5,725.	7,443.

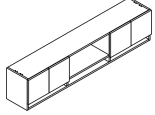

Order Code	Specification Information	Application Notes
Example: <b>ROMGHOC SHP601</b> <b>( ) ( ) ( ) ( )</b>	<i>To order please specify:</i>	These products are Glue and Dowel Construction
<b>R</b> Reff	1. Case finish type: L = Laminate	Letter depth is 15" nominal.
<b>O</b> Overhead	1 = V1	Fascias ordered separately
<b>M</b> Wall mount	2 = V2	Tasklights not included
<b>GHOC</b> Glass hinge door/Open/Cubby	3 = V3	Tack/Task panel order separately
<b>SH</b> Single high	2. Front finish type: L = Laminate	Unfinished backs
<b>P</b> Planning	1 = V1	Wall hung cabinets come with wall hung cleats
<b>60</b> Width	2 = V2	Doors project below shelf for openings
	3 = V3	No pull options
	3. Lock option: N = no lock drilling	
	L = locking	
	4. Lock finish: B=Black	
	S=Matte silver	
	5. Case finish	
	6. Front finish	

dimensions noted nominal

## Single high

## Cabinet hung with and without Center Gables

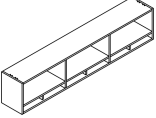
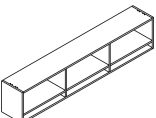
description	h	w	d	pattern no.	L	V1	V2	V3
Cabinet-hung overhead cabinet open /cubby with center gable 	20"	30"	15"	<b>ROCCGSH301</b> ( )( )	\$1,249.	\$1,749.	\$2,011.	\$2,614.
	20"	36"	15"	<b>ROCCGSH361</b> ( )( )	1,284.	1,798.	2,067.	2,688.
	20"	42"	15"	<b>ROCCGSH421</b> ( )( )	1,388.	1,944.	2,235.	2,906.
	20"	48"	15"	<b>ROCCGSH481</b> ( )( )	1,427.	1,997.	2,297.	2,986.
	20"	54"	15"	<b>ROCCGSH541</b> ( )( )	1,662.	2,327.	2,676.	3,479.
	20"	60"	15"	<b>ROCCGSH601</b> ( )( )	1,919.	2,687.	3,090.	4,017.
	20"	66"	15"	<b>ROCCGSH661</b> ( )( )	1,952.	2,732.	3,142.	4,085.
	20"	72"	15"	<b>ROCCGSH721</b> ( )( )	1,990.	2,786.	3,203.	4,164.
	20"	78"	15"	<b>ROCCGSH781</b> ( )( )	2,071.	2,899.	3,334.	4,334.
	20"	84"	15"	<b>ROCCGSH841</b> ( )( )	2,400.	3,361.	3,865.	5,024.
	20"	90"	15"	<b>ROCCGSH901</b> ( )( )	2,439.	3,414.	3,926.	5,104.
20"	96"	15"	<b>ROCCGSH961</b> ( )( )	2,476.	3,466.	3,986.	5,182.	
Cabinet-hung overhead cabinet open /cubby without center gable 	20"	30"	15"	<b>ROCOCSHP301</b> ( )( )	1,124.	1,574.	1,810.	2,353.
	20"	36"	15"	<b>ROCOCSHP361</b> ( )( )	1,156.	1,618.	1,860.	2,419.
	20"	42"	15"	<b>ROCOCSHP421</b> ( )( )	1,249.	1,750.	2,012.	2,615.
	20"	48"	15"	<b>ROCOCSHP481</b> ( )( )	1,284.	1,797.	2,067.	2,687.
	20"	54"	15"	<b>ROCOCSHP541</b> ( )( )	1,496.	2,094.	2,408.	3,131.
	20"	60"	15"	<b>ROCOCSHP601</b> ( )( )	1,727.	2,418.	2,781.	3,615.
	20"	66"	15"	<b>ROCOCSHP661</b> ( )( )	1,757.	2,459.	2,828.	3,677.
	20"	72"	15"	<b>ROCOCSHP721</b> ( )( )	1,791.	2,507.	2,883.	3,748.
	20"	78"	15"	<b>ROCOCSHP781</b> ( )( )	1,864.	2,609.	3,001.	3,901.
	20"	84"	15"	<b>ROCOCSHP841</b> ( )( )	2,160.	3,025.	3,479.	4,522.
	20"	90"	15"	<b>ROCOCSHP901</b> ( )( )	2,195.	3,073.	3,533.	4,594.
20"	96"	15"	<b>ROCOCSHP961</b> ( )( )	2,228.	3,119.	3,587.	4,664.	

Without center gable

Order Code	Specification Information	Application Notes
Example: <b>ROCCGSH301S0</b> <b>( )( )</b>	<i>To order please specify:</i>	These products are Glue and Dowel Construction
<b>R</b> Reff	1. Case Finish type:	Letter depth is 15" nominal.
<b>O</b> Overhead	L = Lamine	Place holder for legal depth if required (20").
<b>C</b> Cabinet hung	1 = V1	Fascias ordered separately
<b>CG</b> Center Gable	2 = V2	Tasklights ordered separately
<b>SH</b> Single high	3 = V3	Tack/Task panel order separately
<b>30</b> 30" width	2. Case finish: V316	Unfinished back
<b>P</b> Planning		Installation instruction sheets available on line.
<b>1</b> Depth (letter)		For Cabinet hung overheads, refer to part number 6TP00080.
<b>2</b> Case finish		
<b>V316</b> Case finish		

dimensions noted nominal

Overhead, 28<sup>3</sup>/<sub>8</sub>" planning  
Single high  
Cabinet hung with doors

Reff Profiles

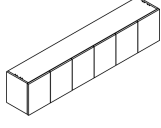
description	w	d	h	pattern no.	L/L	L/V1	L/V2	L/V3	V1/V1	V2/V2	V3/V3	
Cabinet-hung overhead cabinet hinge door, cubby concealed 	30"	15"	20"	ROCHSHP301	(X)(X)(X)(X)(X)	\$1,877.	\$2,064.	\$2,158.	\$2,252.	\$2,627.	\$3,021.	\$3,928.
	36"	15"	20"	ROCHSHP361	(X)(X)(X)(X)(X)	1,921.	2,114.	2,210.	2,306.	2,690.	3,094.	4,022.
	42"	15"	20"	ROCHSHP421	(X)(X)(X)(X)(X)	2,449.	2,693.	2,816.	2,938.	3,428.	3,942.	5,125.
	48"	15"	20"	ROCHSHP481	(X)(X)(X)(X)(X)	2,498.	2,748.	2,873.	2,998.	3,497.	4,022.	5,228.
	54"	15"	20"	ROCHSHP541	(X)(X)(X)(X)(X)	2,649.	2,914.	3,047.	3,179.	3,709.	4,265.	5,545.
	60"	15"	20"	ROCHSHP601	(X)(X)(X)(X)(X)	2,985.	3,283.	3,433.	3,582.	4,179.	4,806.	6,247.
	66"	15"	20"	ROCHSHP661	(X)(X)(X)(X)(X)	3,031.	3,334.	3,486.	3,638.	4,244.	4,880.	6,345.
	72"	15"	20"	ROCHSHP721	(X)(X)(X)(X)(X)	3,081.	3,389.	3,543.	3,697.	4,313.	4,960.	6,448.
	78"	15"	20"	ROCHSHP781	(X)(X)(X)(X)(X)	3,176.	3,494.	3,653.	3,812.	4,447.	5,114.	6,448.
	84"	15"	20"	ROCHSHP841	(X)(X)(X)(X)(X)	3,993.	4,392.	4,591.	4,791.	5,590.	6,428.	8,356.
90"	15"	20"	ROCHSHP901	(X)(X)(X)(X)(X)	4,039.	4,443.	4,645.	4,847.	5,655.	6,503.	8,454.	
96"	15"	20"	ROCHSHP961	(X)(X)(X)(X)(X)	4,090.	4,499.	4,704.	4,908.	5,726.	6,585.	8,560.	

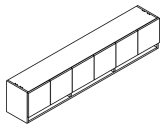
Cabinet-hung overhead cabinet hinge door, cubby exposed 	30"	15"	20"	ROCHCSHP301	(X)(X)(X)(X)(X)	1,783.	1,962.	2,051.	2,140.	2,497.	2,871.	3,732.
	36"	15"	20"	ROCHCSHP361	(X)(X)(X)(X)(X)	1,827.	2,010.	2,101.	2,193.	2,558.	2,942.	3,824.
	42"	15"	20"	ROCHCSHP421	(X)(X)(X)(X)(X)	2,391.	2,631.	2,750.	2,870.	3,348.	3,850.	5,005.
	48"	15"	20"	ROCHCSHP481	(X)(X)(X)(X)(X)	2,470.	2,717.	2,840.	2,964.	3,458.	3,977.	5,170.
	54"	15"	20"	ROCHCSHP541	(X)(X)(X)(X)(X)	2,521.	2,773.	2,899.	3,025.	3,530.	4,059.	5,277.
	60"	15"	20"	ROCHCSHP601	(X)(X)(X)(X)(X)	2,794.	3,073.	3,213.	3,352.	3,911.	4,498.	5,847.
	66"	15"	20"	ROCHCSHP661	(X)(X)(X)(X)(X)	2,834.	3,118.	3,259.	3,401.	3,968.	4,563.	5,932.
	72"	15"	20"	ROCHCSHP721	(X)(X)(X)(X)(X)	2,882.	3,170.	3,314.	3,458.	4,035.	4,640.	6,032.
	78"	15"	20"	ROCHCSHP781	(X)(X)(X)(X)(X)	2,929.	3,222.	3,368.	3,515.	4,101.	4,716.	6,131.
	84"	15"	20"	ROCHCSHP841	(X)(X)(X)(X)(X)	3,692.	4,061.	4,246.	4,430.	5,169.	5,944.	7,727.
90"	15"	20"	ROCHCSHP901	(X)(X)(X)(X)(X)	3,753.	4,128.	4,316.	4,503.	5,254.	6,042.	7,854.	
96"	15"	20"	ROCHCSHP961	(X)(X)(X)(X)(X)	3,799.	4,179.	4,369.	4,559.	5,318.	6,116.	7,951.	

Order Code	Specification Information	Application Notes
Example: <b>ROCHSHP30</b> (X)(X)(X)(X)(X)	<i>To order please specify:</i>	These products are Glue and Dowel Construction
<b>R</b> Reff	1. Case Finish: L = Laminate	Letter depth is 15" nominal.
<b>O</b> Overhead	1 = V1	Fascias ordered separately
<b>C</b> Cabinet mount	2 = V2	Tasklights not included
<b>H</b> Hinge door	3 = V3	Tack/Task panel order separately
<b>SH</b> Single High	2. Front Finish: L = Laminate	Unfinished backs
<b>P</b> Planning	1 = V1	Installation instruction sheets available on line.
<b>30</b> Width	2 = V2	For Cabinet hung overheads, refer to part number 6TP00080.
<b>1</b> Depth (letter)	3 = V3	
<b>2</b> Case finish type	3. Pull option: B=Blank, R=Cylinder, T=Tab, F=Bar, H=Outline	
<b>2</b> Front finish type	4. Lock option: N=no drilling, L=locking (wood or laminate doors only)	
<b>H</b> Pull option	5. Lock finish: B=Black, S=Matte silver	
<b>L</b> Lock option	6. Pull option: Grommet pull only	
<b>B</b> Lock finish	7. Pull finish: Painted, PN= Black Nickel, PD=Polished chrome, PU=Satin Nickel	
<b>PU</b> Pull finish		

dimensions noted nominal



Overhead, 28<sup>3</sup>/<sub>8</sub>" planning  
*Single high*  
*Cabinet hung with glass doors*

description	w	d	h	pattern no.	L	V1	V2	V3
Cabinet-hung overhead cabinet	30"	15"	20"	<b>ROCGHCSHP301</b> ( ) ( ) ( )	\$2,546.	\$2,775.	\$3,192.	\$4,149.
glass hinge door, cubby exposed	36"	15"	20"	<b>ROCGHCSHP361</b> ( ) ( ) ( )	2,658.	2,897.	3,332.	4,331.
	42"	15"	20"	<b>ROCGHCSHP421</b> ( ) ( ) ( )	3,387.	3,692.	4,245.	5,519.
	48"	15"	20"	<b>ROCGHCSHP481</b> ( ) ( ) ( )	3,481.	3,794.	4,363.	5,672.
	54"	15"	20"	<b>ROCGHCSHP541</b> ( ) ( ) ( )	3,722.	4,057.	4,665.	6,065.
	60"	15"	20"	<b>ROCGHCSHP601</b> ( ) ( ) ( )	4,129.	4,501.	5,176.	6,729.
	66"	15"	20"	<b>ROCGHCSHP661</b> ( ) ( ) ( )	4,250.	4,632.	5,327.	6,925.
	72"	15"	20"	<b>ROCGHCSHP721</b> ( ) ( ) ( )	4,353.	4,745.	5,457.	7,094.
	78"	15"	20"	<b>ROCGHCSHP781</b> ( ) ( ) ( )	4,516.	4,922.	5,660.	7,358.
	84"	15"	20"	<b>ROCGHCSHP841</b> ( ) ( ) ( )	5,556.	6,056.	6,965.	9,054.
	90"	15"	20"	<b>ROCGHCSHP901</b> ( ) ( ) ( )	5,621.	6,127.	7,046.	9,159.
	96"	15"	20"	<b>ROCGHCSHP961</b> ( ) ( ) ( )	5,742.	6,259.	7,198.	9,357.

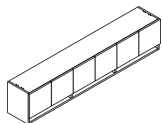

Order Code	Specification Information	Application Notes
Example: <b>ROCGHCSHP301</b> ( ) ( ) ( )	<i>To order please specify:</i>	These products are Glue and Dowel Construction
<b>R</b> Reff	1. Case Finish: L = Laminate 1 = V1 2 = V2 3 = V3	Letter depth is 15" nominal.
<b>O</b> Overhead	2. Case Finish: V316	Fascias ordered separately
<b>C</b> Cabinet mount	3. Door frame finish: Anodized or Painted	Tasklights not included
<b>GHC</b> Glas hinge door/ cubby	4. Glass door finish: GL11, GL15, GL18	Tack/Task panel order separately
<b>SH</b> Single High		Unfinished backs
<b>P</b> Planning		No pull option for glass doors. Doors project below shelf for opening.
<b>30</b> Width		Installation instruction sheets available on line.
<b>1</b> Depth (letter)		For Cabinet hung overheads, refer to part number 6TP00080.
<b>2</b> Case finish type		
<b>V316</b> Case finish		
<b>AU</b> Door frame finish		
<b>GL11</b> Door glass finish		

dimensions noted nominal

Overhead, 28<sup>3</sup>/<sub>8</sub>" planning  
 Single high  
 Cabinet hung with doors, open

description	w	d	h	pattern no.	L/L	L/V1	L/V2	L/V3	V1/V1	V2/V2	V3/V3
Cabinet Hung overhead cabinet	60"	15"	20"	<b>ROCHOCSHP601</b> ( ) ( ) ( ) ( ) ( ) ( )	\$2,465.	\$2,712.	\$2,835.	\$2,958.	\$3,575.	\$4,111.	\$5,344.
hinge door / open /	66"	15"	20"	<b>ROCHOCSHP661</b> ( ) ( ) ( ) ( ) ( ) ( )	2,500.	2,751.	2,876.	3,001.	3,626.	4,170.	5,420.
cubby exposed	72"	15"	20"	<b>ROCHOCSHP721</b> ( ) ( ) ( ) ( ) ( ) ( )	2,541.	2,795.	2,922.	3,049.	3,684.	4,237.	5,508.
	78"	15"	20"	<b>ROCHOCSHP781</b> ( ) ( ) ( ) ( ) ( ) ( )	2,591.	2,850.	2,980.	3,109.	3,757.	4,321.	5,617.
	84"	15"	20"	<b>ROCHOCSHP841</b> ( ) ( ) ( ) ( ) ( ) ( )	3,015.	3,317.	3,468.	3,618.	4,372.	5,028.	6,537.
	90"	15"	20"	<b>ROCHOCSHP901</b> ( ) ( ) ( ) ( ) ( ) ( )	3,061.	3,367.	3,520.	3,673.	4,438.	5,104.	6,635.
	96"	15"	20"	<b>ROCHOCSHP961</b> ( ) ( ) ( ) ( ) ( ) ( )	3,098.	3,408.	3,563.	3,718.	4,492.	5,166.	6,716.

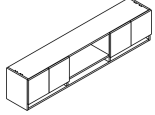

Order Code	Specification Information	Application Notes
Example: <b>ROCHOCSHP601</b> ( ) ( ) ( ) ( ) ( ) ( )	<i>To order please specify:</i>	These products are Glue and Dowel Construction
<b>R</b> Reff	1. Case finish type: L = Laminate	Letter depth is 15" nominal.
<b>O</b> Overhead	1 = V1	Fascias ordered separately
<b>C</b> Cabinet mount	2 = V2	Tasklights not included
<b>HOC</b> Hinge door / Open / Cubby	3 = V3	Tack/Task panel order separately
<b>SH</b> Single High	2. Front finish type: L = Laminate	Unfinished backs
<b>P</b> Planning	1 = V1	Doors project below shelf for opening
<b>60</b> Width	2 = V2	No pull options
<b>1</b> Depth (letter)	3 = V3	Installation instruction sheets available on line.
<b>2</b> Case finish type	3. Lock option: N=no drilling, L=locking (wood or laminate doors only)	For Cabinet hung overheads, refer to part number 6TP00080.
<b>2</b> Front finish type	4. Lock finish: B=Black, S=Matte silver	
<b>L</b> Lock option	5. Case finish	
<b>B</b> Lock finish	6. Front finish	
<b>V316</b> Case finish		
<b>V316</b> Front finish		

dimensions noted nominal

Overhead, 28<sup>3</sup>/<sub>8</sub>" planning  
 Single high  
 Cabinet hung with glass doors, open  
 Cubby exposed

description	w	d	h	pattern no.	L	V1	V2	V3
Cabinet Hung overhead cabinet	60"	15"	20"	<b>ROCGHOC</b> SHP601() ( <b>X</b> )( <b>X</b> )( <b>X</b> )( <b>X</b> )	\$3,027.	\$3,784.	\$4,351.	\$5,657.
glass hinge door / open /	66"	15"	20"	<b>ROCGHOC</b> SHP661() ( <b>X</b> )( <b>X</b> )( <b>X</b> )( <b>X</b> )	3,097.	3,871.	4,452.	5,788.
cubby exposed	72"	15"	20"	<b>ROCGHOC</b> SHP721() ( <b>X</b> )( <b>X</b> )( <b>X</b> )( <b>X</b> )	3,161.	3,951.	4,544.	5,907.
	78"	15"	20"	<b>ROCGHOC</b> SHP781() ( <b>X</b> )( <b>X</b> )( <b>X</b> )( <b>X</b> )	3,234.	4,043.	4,649.	6,044.
	84"	15"	20"	<b>ROCGHOC</b> SHP841() ( <b>X</b> )( <b>X</b> )( <b>X</b> )( <b>X</b> )	3,970.	4,764.	5,478.	7,122.
	90"	15"	20"	<b>ROCGHOC</b> SHP901() ( <b>X</b> )( <b>X</b> )( <b>X</b> )( <b>X</b> )	4,017.	4,820.	5,544.	7,207.
	96"	15"	20"	<b>ROCGHOC</b> SHP961() ( <b>X</b> )( <b>X</b> )( <b>X</b> )( <b>X</b> )	4,099.	4,919.	5,657.	7,354.

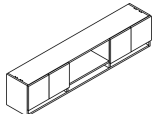

Order Code	Specification Information	Application Notes
Example: <b>ROCGHOC</b> SHP601 ( <b>X</b> )( <b>X</b> )( <b>X</b> )( <b>X</b> )	<i>To order please specify:</i>	These products are Glue and Dowel Construction
<b>R</b> Reff	1. Case finish type: L = Laminate	Letter depth is 15" nominal.
<b>O</b> Overhead	1 = V1	Fascias ordered separately
<b>C</b> Cabinet mount	2 = V2	Tasklights not included
<b>GHOC</b> Glass hinge door / Open / Cubby	3 = V3	Tack/Task panel order separately
<b>SH</b> Single High	2. Front finish type: L = Laminate	Unfinished backs
<b>P</b> Planning	1 = V1	Doors project below shelf for opening
<b>60</b> Width	2 = V2	No pull options
<b>1</b> Depth (letter)	3 = V3	Installation instruction sheets available on line.
	3. Lock option: N=no drilling, L=locking (wood or laminate doors only)	For Cabinet hung overheads, refer to part number 6TP00080.
	4. Lock finish: B=Black, S=Matte silver	
	5. Case finish	
	6. Front finish	

dimensions noted nominal

Overhead storage

# Overhead, 28<sup>3</sup>/<sub>8</sub>" planning

Reff Profiles

## Double high

## Wall hung

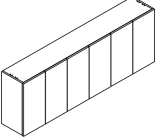
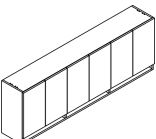
description	w	d	h	pattern no.	L/L	L/V1	L/V2	L/V3	V1/V1	V2/V2	V3/V3
Wall-hung overhead cabinet hinge door, cubby concealed 	30"	15"	33"	<b>ROMHDHP301</b> ( ) ( ) ( ) ( ) ( ) ( )	\$2,133.	\$2,346.	\$2,453.	\$2,560.	\$2,986.	\$3,434.	\$4,464.
	36"	15"	33"	<b>ROMHDHP361</b> ( ) ( ) ( ) ( ) ( ) ( )	2,205.	2,426.	2,536.	2,646.	3,087.	3,550.	4,615.
	42"	15"	33"	<b>ROMHDHP421</b> ( ) ( ) ( ) ( ) ( ) ( )	2,954.	3,249.	3,397.	3,545.	4,136.	4,756.	6,183.
	48"	15"	33"	<b>ROMHDHP481</b> ( ) ( ) ( ) ( ) ( ) ( )	3,040.	3,343.	3,495.	3,647.	4,255.	4,894.	6,362.
	54"	15"	33"	<b>ROMHDHP541</b> ( ) ( ) ( ) ( ) ( ) ( )	3,224.	3,547.	3,708.	3,869.	4,514.	5,191.	6,749.
	60"	15"	33"	<b>ROMHDHP601</b> ( ) ( ) ( ) ( ) ( ) ( )	3,550.	3,905.	4,082.	4,259.	4,969.	5,715.	7,429.
	66"	15"	33"	<b>ROMHDHP661</b> ( ) ( ) ( ) ( ) ( ) ( )	3,662.	4,028.	4,212.	4,395.	5,127.	5,896.	7,665.
	72"	15"	33"	<b>ROMHDHP721</b> ( ) ( ) ( ) ( ) ( ) ( )	3,737.	4,111.	4,298.	4,485.	5,232.	6,017.	7,822.
	78"	15"	33"	<b>ROMHDHP781</b> ( ) ( ) ( ) ( ) ( ) ( )	3,861.	4,247.	4,440.	4,633.	5,405.	6,215.	8,080.
	84"	15"	33"	<b>ROMHDHP841</b> ( ) ( ) ( ) ( ) ( ) ( )	4,878.	5,366.	5,610.	5,854.	6,829.	7,854.	10,210.
	90"	15"	33"	<b>ROMHDHP901</b> ( ) ( ) ( ) ( ) ( ) ( )	4,965.	5,462.	5,710.	5,958.	6,951.	7,994.	10,392.
96"	15"	33"	<b>ROMHDHP961</b> ( ) ( ) ( ) ( ) ( ) ( )	5,030.	5,533.	5,785.	6,036.	7,042.	8,099.	10,528.	
Wall-hung overhead cabinet hinge door, cubby exposed 	30"	15"	33"	<b>ROMHCDHP301</b> ( ) ( ) ( ) ( ) ( ) ( )	2,042.	2,246.	2,348.	3,450.	2,858.	3,287.	4,273.
	36"	15"	33"	<b>ROMHCDHP361</b> ( ) ( ) ( ) ( ) ( ) ( )	2,110.	2,321.	2,426.	2,532.	2,954.	3,397.	4,416.
	42"	15"	33"	<b>ROMHCDHP421</b> ( ) ( ) ( ) ( ) ( ) ( )	2,866.	3,153.	3,296.	3,440.	4,013.	4,615.	5,999.
	48"	15"	33"	<b>ROMHCDHP481</b> ( ) ( ) ( ) ( ) ( ) ( )	2,974.	3,272.	3,420.	3,569.	4,164.	4,788.	6,225.
	54"	15"	33"	<b>ROMHCDHP541</b> ( ) ( ) ( ) ( ) ( ) ( )	3,058.	3,364.	3,517.	3,670.	4,281.	4,923.	6,400.
	60"	15"	33"	<b>ROMHCDHP601</b> ( ) ( ) ( ) ( ) ( ) ( )	3,357.	3,692.	3,860.	4,028.	4,699.	5,404.	7,026.
	66"	15"	33"	<b>ROMHCDHP661</b> ( ) ( ) ( ) ( ) ( ) ( )	3,465.	3,812.	3,985.	4,158.	5,851.	5,579.	7,253.
	72"	15"	33"	<b>ROMHCDHP721</b> ( ) ( ) ( ) ( ) ( ) ( )	3,537.	3,891.	4,067.	4,244.	4,952.	5,694.	7,403.
	78"	15"	33"	<b>ROMHCDHP781</b> ( ) ( ) ( ) ( ) ( ) ( )	3,614.	3,976.	4,156.	4,337.	5,060.	5,819.	7,565.
	84"	15"	33"	<b>ROMHCDHP841</b> ( ) ( ) ( ) ( ) ( ) ( )	4,591.	5,050.	5,280.	5,510.	6,428.	7,392.	9,609.
	90"	15"	33"	<b>ROMHCDHP901</b> ( ) ( ) ( ) ( ) ( ) ( )	4,676.	5,144.	5,378.	5,612.	6,547.	7,529.	9,788.
96"	15"	33"	<b>ROMHCDHP961</b> ( ) ( ) ( ) ( ) ( ) ( )	4,739.	5,213.	5,449.	5,686.	6,634.	7,629.	9,918.	

Order Code	Specification Information	Application Notes
Example: <b>ROMHDHP30</b> ( ) ( ) ( ) ( ) ( ) ( )	<i>To order please specify:</i>	These products are Glue and Dowel Construction
<b>R</b> Reff	1. Case Finish: L = Laminate	Letter depth is 15" nominal.
<b>O</b> Overhead	1 = V1	Fascias ordered separately
<b>M</b> Wall mount	2 = V2	Tasklights not included
<b>H</b> Hinge door	3 = V3	Tack/Task panel order separately
<b>DH</b> Double High	2. Front Finish: L = Laminate	Unfinished backs
<b>P</b> Planning	1 = V1	
<b>30</b> Width	2 = V2	
<b>1</b> Depth (letter)	3 = V3	
<b>2</b> Case finish type	3. Pull option: B=Blank, R=Cylinder, T=Tab, F=Bar, H=Outline	
<b>2</b> Front finish type	4. Lock option: N=no drilling, L=locking	
<b>H</b> Pull option	(wood or laminate doors only)	
<b>L</b> Lock option	5. Lock finish: B=Black, S=Matte silver	
<b>B</b> Lock finish	6. Pull option: Grommet pull only	
<b>PU</b> Pull finish	7. Pull finish: Painted, PN= Black Nickel, PD=Polished chrome, PU=Satin Nickel	

dimensions noted nominal

Overhead, 28<sup>3</sup>/<sub>8</sub>" planning  
 Double high  
 Wall hung with glass door

description	w	d	h	pattern n	L	V1	V2	V3
Wall-hung overhead cabinet	30"	15"	33"	ROMGHCDHP301()	\$3,066.	\$3,372.	\$3,878.	\$5,042.
glass hinge door, cubby exposed	36"	15"	33"	ROMGHCDHP361()	3,231.	3,554.	4,087.	5,313.
	42"	15"	33"	ROMGHCDHP421()	4,245.	4,669.	5,369.	6,980.
	48"	15"	33"	ROMGHCDHP481()	4,397.	4,836.	5,562.	7,230.
	54"	15"	33"	ROMGHCDHP541()	4,701.	5,171.	5,947.	7,731.
	60"	15"	33"	ROMGHCDHP601()	5,250.	5,775.	6,641.	8,634.
	66"	15"	33"	ROMGHCDHP661()	5,475.	6,023.	6,926.	9,004.
	72"	15"	33"	ROMGHCDHP721()	5,625.	6,187.	7,115.	9,249.
	78"	15"	33"	ROMGHCDHP781()	5,858.	6,444.	7,411.	9,634.
	84"	15"	33"	ROMGHCDHP841()	7,270.	7,997.	9,197.	11,956.
	90"	15"	33"	ROMGHCDHP901()	7,386.	8,125.	9,343.	12,146.
	96"	15"	33"	ROMGHCDHP961()	7,551.	8,307.	9,552.	12,418.

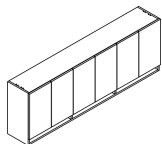

Order Code	Specification Information	Application Notes
Example: <b>ROMGHCDHP301</b> () () ()	<i>To order please specify:</i>	These products are Glue and Dowel Construction
<b>R</b> Reff	1. Case finish type: L, V1, V2, V3	Knoll does not assume any responsibility for the installation, attachment or the securing of wall hung units to the wall.
<b>O</b> Overhead	2. Case finish: V316	A certified building contractor should be consulted.
<b>M</b> Wall mount	3. Door frame finish: Anodized / Painted	Please refer to wall mounting information on page 494.
<b>GHC</b> Glass hinge door / cubby	4. Door glass finish: GL11 GL15 GL18	
<b>DH</b> Double High		
<b>P</b> Planning		
<b>30</b> Width		
<b>1</b> Depth (letter)		
<b>2</b> Case finish type		
<b>V316</b> Case finish		
<b>AN</b> Door frame finish		
<b>GL11</b> Door glass finish		

dimensions noted nominal

Overhead storage

# Overhead, 28<sup>3</sup>/<sub>8</sub>" planning

## Double high

### Wall hung with and without center gable

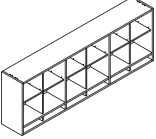
description	w	d	h	pattern no.	L	V1	V2	V3
Wall-hung overhead cabinet open /cubby <b>with</b> center gable 	30"	15"	33"	<b>ROMCGDHP301</b> ( ) ( )	\$1,777.	\$2,487.	\$2,860.	\$3,719.
	36"	15"	33"	<b>ROMCGDHP361</b> ( ) ( )	1,824.	2,553.	2,936.	3,817.
	42"	15"	33"	<b>ROMCGDHP421</b> ( ) ( )	2,242.	3,139.	3,610.	4,693.
	48"	15"	33"	<b>ROMCGDHP481</b> ( ) ( )	2,300.	3,219.	3,702.	4,813.
	54"	15"	33"	<b>ROMCGDHP541</b> ( ) ( )	2,552.	3,573.	4,109.	5,342.
	60"	15"	33"	<b>ROMCGDHP601</b> ( ) ( )	3,031.	4,244.	4,881.	6,345.
	66"	15"	33"	<b>ROMCGDHP661</b> ( ) ( )	3,123.	4,373.	5,029.	6,537.
	72"	15"	33"	<b>ROMCGDHP721</b> ( ) ( )	3,171.	4,440.	5,106.	6,638.
	78"	15"	33"	<b>ROMCGDHP781</b> ( ) ( )	3,282.	4,594.	5,284.	6,869.
	84"	15"	33"	<b>ROMCGDHP841</b> ( ) ( )	4,135.	5,789.	6,657.	8,654.
	90"	15"	33"	<b>ROMCGDHP901</b> ( ) ( )	4,186.	5,860.	6,739.	8,761.
96"	15"	33"	<b>ROMCGDHP961</b> ( ) ( )	4,231.	5,923.	6,812.	8,855.	

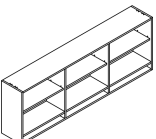
Wall-hung overhead cabinet open /cubby <b>without</b> center gable 	30"	15"	33"	<b>ROMCDHP301</b> ( ) ( )	1,599.	2,238.	2,574.	3,347.
	36"	15"	33"	<b>ROMCDHP361</b> ( ) ( )	1,642.	2,298.	2,642.	3,435.
	42"	15"	33"	<b>ROMCDHP421</b> ( ) ( )	2,018.	2,825.	3,249.	4,224.
	48"	15"	33"	<b>ROMCDHP481</b> ( ) ( )	2,070.	2,897.	3,332.	4,332.
	54"	15"	33"	<b>ROMCDHP541</b> ( ) ( )	2,297.	3,216.	3,698.	4,808.
	60"	15"	33"	<b>ROMCDHP601</b> ( ) ( )	2,728.	3,820.	4,393.	5,711.
	66"	15"	33"	<b>ROMCDHP661</b> ( ) ( )	2,811.	3,936.	4,526.	5,883.
	72"	15"	33"	<b>ROMCDHP721</b> ( ) ( )	2,854.	3,996.	4,595.	5,974.
	78"	15"	33"	<b>ROMCDHP781</b> ( ) ( )	2,954.	4,135.	4,756.	6,182.
	84"	15"	33"	<b>ROMCDHP841</b> ( ) ( )	3,722.	5,210.	5,991.	7,789.
	90"	15"	33"	<b>ROMCDHP901</b> ( ) ( )	3,767.	5,274.	6,065.	7,885.
96"	15"	33"	<b>ROMCDHP961</b> ( ) ( )	3,808.	5,331.	6,131.	7,970.	

*Without center gable*

Order Code	Specification Information	Application Notes
Example: <b>ROMCGDHP301</b> ( ) ( ) ( ) ( ) ( ) ( )	<i>To order please specify:</i>	These products are Glue and Dowel Construction
<b>R</b> Reff	1. Case finish type:	Knoll does not assume any responsibility for the installation, attachment or the securing of wall hung units to the wall.
<b>O</b> Overhead	L = Laminate	A certified building contractor should be consulted.
<b>M</b> Wall mount	1 = V1	Please refer to wall mounting information on page 494.
<b>CG</b> Center Gable	2 = V2	
<b>DH</b> Double High	3 = V3	
<b>P</b> Planning	2. Case finish: V316	Fascias ordered separately
<b>30</b> Width		Tasklights not included
<b>1</b> Depth (letter)		Tack/Task panel order separately
<b>2</b> Case finish type		Unfinished backs
<b>V316</b> Case finish		

*dimensions noted nominal*

Overhead, 28<sup>3</sup>/<sub>8</sub>" planning  
*Double high*  
*Wall hung with doors, open*

description	w	d	h	pattern no.	L/L	L/V1	L/V2	L/V3	V1/V1	V2/V2	V3/V3	
Wall Hung overhead cabinet	60"	15"	33"	ROMHOC DHP601	( ) ( ) ( ) ( ) ( ) ( )	\$3,174.	\$3,492.	\$3,650.	\$3,809.	\$4,602.	\$5,293.	\$6,881.
hinge door / open /	66"	15"	33"	ROMHOC DHP661	( ) ( ) ( ) ( ) ( ) ( )	3,227.	3,550.	3,711.	3,872.	4,679.	5,381.	6,995.
cubby exposed	72"	15"	33"	ROMHOC DHP721	( ) ( ) ( ) ( ) ( ) ( )	3,288.	3,617.	3,781.	3,946.	4,768.	5,483.	7,128.
	78"	15"	33"	ROMHOC DHP781	( ) ( ) ( ) ( ) ( ) ( )	3,352.	3,687.	3,855.	4,023.	4,861.	5,590.	7,267.
	84"	15"	33"	ROMHOC DHP841	( ) ( ) ( ) ( ) ( ) ( )	3,861.	4,247.	4,440.	4,633.	5,598.	6,438.	8,370.
	90"	15"	33"	ROMHOC DHP901	( ) ( ) ( ) ( ) ( ) ( )	3,926.	4,318.	4,515.	4,711.	5,692.	6,546.	8,510.
	96"	15"	33"	ROMHOC DHP961	( ) ( ) ( ) ( ) ( ) ( )	3,983.	4,381.	4,580.	4,780.	5,775.	6,642.	8,634.

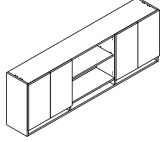

Order Code	Specification Information	Application Notes
Example: <b>ROMHOC DHP601</b> ( ) ( ) ( ) ( ) ( ) ( )	<i>To order please specify:</i>	These products are Glue and Dowel Construction
<b>R</b> Reff	1. Case Finish: L = Laminate	Letter depth is 15" nominal.
<b>O</b> Overhead	1 = V1	Fascias ordered separately
<b>M</b> Wall mount	2 = V2	Tasklights not included
<b>HOC</b> Hinge door / open / cubby	3 = V3	Tack/Task panel order separately
<b>DH</b> Double High	2. Front Finish: L = Laminate	Unfinished backs
<b>P</b> Planning	1 = V1	Doors project below shelf for opening
<b>60</b> Width	2 = V2	No pull option
<b>1</b> Depth (letter)	3 = V3	
<b>2</b> Case finish type	3. Lock Option: N=no drilling, L=locking (wood or laminate doors only)	
<b>2</b> Front finish type	4. Lock finish: B=Black, S=Matte silver	
<b>L</b> Lock option	5. Case Finish	
<b>B</b> Lock finish	6. Front Finish	
<b>V316</b> Case finish		
<b>V316</b> Front finish		

dimensions noted nominal

Overhead, 28<sup>3</sup>/<sub>8</sub>" planning  
 Double high  
 Wall hung with glass doors, open  
 Cubby exposed

description	w	d	h	pattern no.	L	V1	V2	V3
Wall Hung overhead cabinet	60"	15"	33"	<b>ROMGHOCDHP601</b> ( ) ( ) ( ) ( ) ( )	\$4,035.	\$5,043.	\$5,800.	\$7,540.
glass hinge door / open /	66"	15"	33"	<b>ROMGHOCDHP661</b> ( ) ( ) ( ) ( ) ( )	4,140.	5,176.	5,952.	7,737.
cubby exposed	72"	15"	33"	<b>ROMGHOCDHP721</b> ( ) ( ) ( ) ( ) ( )	4,236.	5,295.	6,089.	7,915.
	78"	15"	33"	<b>ROMGHOCDHP781</b> ( ) ( ) ( ) ( ) ( )	4,364.	5,432.	6,247.	8,121.
	84"	15"	33"	<b>ROMGHOCDHP841</b> ( ) ( ) ( ) ( ) ( )	5,240.	6,445.	7,412.	9,635.
	90"	15"	33"	<b>ROMGHOCDHP901</b> ( ) ( ) ( ) ( ) ( )	5,321.	6,545.	7,527.	9,785.
	96"	15"	33"	<b>ROMGHOCDHP961</b> ( ) ( ) ( ) ( ) ( )	5,439.	6,690.	7,693.	10,001.

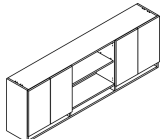

Order Code	Specification Information	Application Notes
Example: <b>ROMGHOCDHP601</b> ( ) ( ) ( ) ( ) ( )	<i>To order please specify:</i>	These products are Glue and Dowel Construction
<b>R</b> Reff	1. Case Finish: L = Laminate	Letter depth is 15" nominal.
<b>O</b> Overhead	1 = V1	Fascias ordered separately
<b>M</b> Wall mount	2 = V2	Tasklights not included
<b>GHOC</b> Glass hinge door / open / cubby	3 = V3	Tack/Task panel order separately
<b>DH</b> Double High	2. Front Finish: L = Laminate	Unfinished backs
<b>P</b> Planning	1 = V1	Doors project below shelf for opening
<b>60</b> Width	2 = V2	No pull option
<b>1</b> Depth (letter)	3 = V3	
	3. Lock Option: N=no drilling, L=locking (wood or laminate doors only)	
	4. Lock finish: B=Black, S=Matte silver	
	5. Case Finish	
	6. Front Finish	

dimensions noted nominal



Double high  
Cabinet hung

description	w	d	h	pattern no.	L/L	L/V1	L/V2	L/V3	V1/V1	V2/V2	V3/V3	
Cabinet-hung overhead cabinet hinge door, cubby concealed	30"	15"	33"	ROCHDHP301	(X)(X)(X)(X)(X)	\$2,204.	\$2,425.	\$2,535.	\$2,645.	\$3,086.	\$3,549.	\$4,613.
	36"	15"	33"	ROCHDHP361	(X)(X)(X)(X)(X)	2,274.	2,502.	2,615.	2,729.	3,184.	3,662.	4,760.
	42"	15"	33"	ROCHDHP421	(X)(X)(X)(X)(X)	3,022.	3,324.	3,475.	3,627.	4,231.	4,866.	6,325.
	48"	15"	33"	ROCHDHP481	(X)(X)(X)(X)(X)	3,093.	3,403.	3,557.	3,712.	4,331.	4,980.	6,474.
	54"	15"	33"	ROCHDHP541	(X)(X)(X)(X)(X)	3,276.	3,604.	3,768.	3,931.	4,587.	5,275.	6,857.
	60"	15"	33"	ROCHDHP601	(X)(X)(X)(X)(X)	3,600.	3,960.	4,140.	4,320.	5,041.	5,797.	7,536.
	66"	15"	33"	ROCHDHP661	(X)(X)(X)(X)(X)	3,711.	4,082.	4,268.	4,453.	5,195.	5,975.	7,767.
	72"	15"	33"	ROCHDHP721	(X)(X)(X)(X)(X)	3,787.	4,165.	4,355.	4,544.	5,301.	6,097.	7,926.
	78"	15"	33"	ROCHDHP781	(X)(X)(X)(X)(X)	3,894.	4,283.	4,478.	4,673.	5,452.	6,269.	8,150.
	84"	15"	33"	ROCHDHP841	(X)(X)(X)(X)(X)	4,910.	5,401.	5,646.	5,892.	6,873.	7,904.	10,276.
90"	15"	33"	ROCHDHP901	(X)(X)(X)(X)(X)	4,995.	5,494.	5,744.	5,994.	6,993.	8,041.	10,454.	
96"	15"	33"	ROCHDHP961	(X)(X)(X)(X)(X)	5,059.	5,564.	5,817.	6,070.	7,082.	8,144.	10,588.	

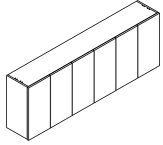

Cabinet-hung overhead cabinet hinge door, cubby exposed	30"	15"	33"	ROCHDHP301	(X)(X)(X)(X)(X)	2,112.	2,323.	2,428.	2,534.	2,956.	3,400.	4,419.
	36"	15"	33"	ROCHDHP361	(X)(X)(X)(X)(X)	2,178.	2,396.	2,504.	2,613.	3,049.	3,506.	4,558.
	42"	15"	33"	ROCHDHP421	(X)(X)(X)(X)(X)	2,955.	3,251.	3,398.	3,546.	4,137.	4,758.	6,185.
	48"	15"	33"	ROCHDHP481	(X)(X)(X)(X)(X)	3,026.	3,329.	3,480.	3,632.	4,237.	4,873.	6,334.
	54"	15"	33"	ROCHDHP541	(X)(X)(X)(X)(X)	3,108.	3,419.	3,574.	3,730.	4,352.	5,004.	6,506.
	60"	15"	33"	ROCHDHP601	(X)(X)(X)(X)(X)	3,405.	3,745.	3,916.	4,086.	4,767.	5,482.	7,126.
	66"	15"	33"	ROCHDHP661	(X)(X)(X)(X)(X)	3,511.	3,863.	4,038.	4,214.	4,916.	5,653.	7,349.
	72"	15"	33"	ROCHDHP721	(X)(X)(X)(X)(X)	3,584.	3,942.	4,121.	4,300.	5,017.	5,770.	7,500.
	78"	15"	33"	ROCHDHP781	(X)(X)(X)(X)(X)	3,645.	4,009.	4,192.	4,374.	5,103.	5,868.	7,629.
	84"	15"	33"	ROCHDHP841	(X)(X)(X)(X)(X)	4,619.	5,081.	5,312.	5,543.	6,466.	7,436.	9,667.
90"	15"	33"	ROCHDHP901	(X)(X)(X)(X)(X)	4,702.	5,172.	5,407.	5,642.	6,583.	7,570.	9,841.	
96"	15"	33"	ROCHDHP961	(X)(X)(X)(X)(X)	4,763.	5,239.	5,477.	5,716.	6,668.	7,668.	9,969.	

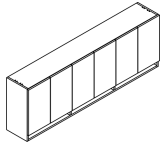

Order Code	Specification Information	Application Notes
Example: <b>ROCHDHP301</b> (X)(X)(X)(X)(X)	<i>To order please specify:</i>	These products are Glue and Dowel Construction
<b>R</b> Reff	1. Case Finish: L = Laminate	Letter depth is 15" nominal.
<b>O</b> Overhead	1 = V1	Fascias ordered separately
<b>C</b> Cabinet Hung	2 = V2	Tasklights not included
<b>H</b> Hinge door	3 = V3	Tack/Task panel order separately
<b>DH</b> Double High	2. Front Finish: L = Laminate	Unfinished backs
<b>P</b> Planning	1 = V1	Installation instruction sheets available on line.
<b>30</b> Width	2 = V2	For Cabinet hung overheads, refer to part number 6TP00080.
<b>1</b> Depth (letter)	3 = V3	
<b>2</b> Case finish type	3. Pull option: B=Blank, R=Cylinder, T=Tab, F=Bar, H=Outline	
<b>2</b> Front finish type	4. Lock option: N=no drilling, L=locking (wood or laminate doors only)	
<b>H</b> Pull option	5. Lock finish: B=Black, S=Matte silver	
<b>L</b> Lock option	6. Case finish: V316	
<b>B</b> Lock finish	7. Front finish: V316	
<b>V316</b> Case finish	8. Pull finish: Painted, PN= Black Nickel, PD=Polished chrome, PU=Satin Nickel	
<b>V316</b> Front finish		
<b>PN</b> Pull finish		

dimensions noted nominal

Overhead, 28<sup>3</sup>/<sub>8</sub>" planning  
*Double high*  
*Cabinet hung with glass door*

description	w	d	h	pattern n	L	V1	V2	V3
Cabinet-hung overhead cabinet	30"	15"	33"	<b>ROCGHCDHP301</b> ( ) ( ) ( )	\$3,108.	\$3,387.	\$3,895.	\$5,064.
glass hinge door, cubby exposed	36"	15"	33"	<b>ROCGHCDHP361</b> ( ) ( ) ( )	3,272.	3,566.	4,101.	5,332.
	42"	15"	33"	<b>ROCGHCDHP421</b> ( ) ( ) ( )	4,293.	4,680.	5,382.	6,996.
	48"	15"	33"	<b>ROCGHCDHP481</b> ( ) ( ) ( )	4,429.	4,827.	5,551.	7,216.
	54"	15"	33"	<b>ROCGHCDHP541</b> ( ) ( ) ( )	4,733.	5,159.	5,933.	7,713.
	60"	15"	33"	<b>ROCGHCDHP601</b> ( ) ( ) ( )	5,083.	5,541.	6,372.	8,284.
	66"	15"	33"	<b>ROCGHCDHP661</b> ( ) ( ) ( )	5,300.	5,777.	6,644.	8,637.
	72"	15"	33"	<b>ROCGHCDHP721</b> ( ) ( ) ( )	5,471.	5,964.	6,858.	8,916.
	78"	15"	33"	<b>ROCGHCDHP781</b> ( ) ( ) ( )	5,689.	6,201.	7,131.	9,270.
	84"	15"	33"	<b>ROCGHCDHP841</b> ( ) ( ) ( )	6,924.	7,547.	8,679.	11,283.
	90"	15"	33"	<b>ROCGHCDHP901</b> ( ) ( ) ( )	7,038.	7,672.	8,823.	11,469.
	96"	15"	33"	<b>ROCGHCDHP961</b> ( ) ( ) ( )	7,203.	7,851.	9,028.	11,737.

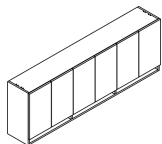

Order Code	Specification Information	Application Notes
Example: <b>ROCGHCDHP301</b> ( ) ( ) ( )	<i>To order please specify:</i>	These products are Glue and Dowel Construction
<b>R</b> Reff	1. Case Finish Type: L = Laminate 1 = V1 2 = V2 3 = V3	Letter depth is 15" nominal.
<b>O</b> Overhead	2. Case Finish: V316	No glass shelves
<b>C</b> Cabinet Hung	3. Door frame finish: Anotized or Painted	Fascias ordered separately
<b>GHC</b> Glass hinge door / cubby	4. Door Glass finish: GL11, GL15, GL18	Tasklights not included
<b>DH</b> Double High		Tack/Task panel order separately
<b>P</b> Planning		Unfinished backs
<b>30</b> Width		No pull option for glass doors. Doors project below shelf for opening.
<b>1</b> Depth (letter)		Installation instruction sheets available on line.
<b>2</b> Case finish type		For Cabinet hung overheads, refer to part number 6TP00080.
<b>2</b> Caese finish		
<b>AN</b> Door frame finish		
<b>GL11</b> Door glass finish		

dimensions noted nominal

## Double high

## Cabinet hung with and without center gable

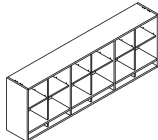
description	w	d	h	pattern no.	L	V1	V2	V3
Cabinet-hung overhead cabinet open /cubby <b>with</b> center gable 	30"	15"	33"	<b>ROCCGDHP301</b> ( ) ( )	\$1,849.	\$2,588.	\$2,976.	\$3,869.
	36"	15"	33"	<b>ROCCGDHP361</b> ( ) ( )	1,894.	2,651.	3,049.	3,963.
	42"	15"	33"	<b>ROCCGDHP421</b> ( ) ( )	2,311.	3,235.	3,721.	4,837.
	48"	15"	33"	<b>ROCCGDHP481</b> ( ) ( )	2,354.	3,295.	3,790.	4,927.
	54"	15"	33"	<b>ROCCGDHP541</b> ( ) ( )	2,605.	3,646.	4,193.	5,451.
	60"	15"	33"	<b>ROCCGDHP601</b> ( ) ( )	3,083.	4,316.	4,963.	6,452.
	66"	15"	33"	<b>ROCCGDHP661</b> ( ) ( )	3,173.	4,442.	5,108.	6,640.
	72"	15"	33"	<b>ROCCGDHP721</b> ( ) ( )	3,221.	4,510.	5,186.	6,742.
	78"	15"	33"	<b>ROCCGDHP781</b> ( ) ( )	3,316.	4,642.	5,338.	6,939.
	84"	15"	33"	<b>ROCCGDHP841</b> ( ) ( )	4,166.	5,833.	6,708.	8,720.
	90"	15"	33"	<b>ROCCGDHP901</b> ( ) ( )	4,215.	5,901.	6,787.	8,823.
96"	15"	33"	<b>ROCCGDHP961</b> ( ) ( )	4,260.	5,963.	6,858.	8,915.	

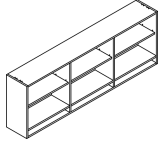
Cabinet-hung overhead cabinet open /cubby <b>without</b> center gable 	30"	15"	33"	<b>ROCOCDHP301</b> ( ) ( )	1,664.	2,329.	2,678.	3,482.
	36"	15"	33"	<b>ROCOCDHP361</b> ( ) ( )	1,705.	2,386.	2,744.	3,567.
	42"	15"	33"	<b>ROCOCDHP421</b> ( ) ( )	2,080.	2,912.	3,349.	4,353.
	48"	15"	33"	<b>ROCOCDHP481</b> ( ) ( )	2,119.	2,966.	3,411.	4,434.
	54"	15"	33"	<b>ROCOCDHP541</b> ( ) ( )	2,345.	3,281.	3,774.	4,906.
	60"	15"	33"	<b>ROCOCDHP601</b> ( ) ( )	2,775.	3,884.	4,467.	5,807.
	66"	15"	33"	<b>ROCOCDHP661</b> ( ) ( )	2,856.	3,998.	4,597.	5,976.
	72"	15"	33"	<b>ROCOCDHP721</b> ( ) ( )	2,899.	4,059.	4,667.	6,068.
	78"	15"	33"	<b>ROCOCDHP781</b> ( ) ( )	2,984.	4,178.	4,804.	6,245.
	84"	15"	33"	<b>ROCOCDHP841</b> ( ) ( )	3,749.	5,250.	6,037.	7,848.
	90"	15"	33"	<b>ROCOCDHP901</b> ( ) ( )	3,794.	5,311.	6,108.	7,941.
96"	15"	33"	<b>ROCOCDHP961</b> ( ) ( )	3,834.	5,367.	6,172.	8,024.	

Without center gable

Order Code	Specification Information	Application Notes
Example: <b>ROCCGDHP301</b> ( ) ( )	<i>To order please specify:</i>	These products are Glue and Dowel Construction
<b>R</b> Reff	1. Case finish type:	Knoll does not assume any responsibility for the installation, attachment or the securing of wall hung units to the wall.
<b>O</b> Overhead	L = Laminated	A certified building contractor should be consulted.
<b>C</b> Cabinet hung	1 = V1	Please refer to wall mounting information on page 494.
<b>CG</b> Center gable	2 = V2	
<b>DH</b> Double High	3 = V3	
<b>P</b> Planning	2. Case finish: V316	Fascias ordered separately
<b>30</b> Width		Tasklights not included
<b>1</b> Depth (letter)		Tack/Task panel order separately
<b>2</b> Case finish type		Unfinished backs
<b>V316</b> Case finish		Installation instruction sheets available on line.

dimensions noted nominal

For Cabinet hung overheads, refer to part number 6TP00080.

Overhead, 28<sup>3</sup>/<sub>8</sub>" planning  
 Double high  
 Cabinet hung with doors, open

description	w	d	h	pattern no.	L/L	L/V1	L/V2	L/V3	V1/V1	V2/V2	V3/V3
Cabinet Hung overhead cabinet	60"	15"	33"	<b>ROCH OCDHP601</b> ( ) ( ) ( ) ( ) ( ) ( )	\$3,165.	\$3,481.	\$3,639.	\$3,798.	\$4,589.	\$5,277.	\$6,860.
hinge door / open /	66"	15"	33"	<b>ROCH OCDHP661</b> ( ) ( ) ( ) ( ) ( ) ( )	3,216.	3,537.	3,698.	3,859.	4,663.	5,362.	6,971.
cubby exposed	72"	15"	33"	<b>ROCH OCDHP721</b> ( ) ( ) ( ) ( ) ( ) ( )	3,276.	3,603.	3,767.	3,931.	4,750.	5,463.	7,101.
	78"	15"	33"	<b>ROCH OCDHP781</b> ( ) ( ) ( ) ( ) ( ) ( )	3,326.	3,659.	3,825.	3,991.	4,823.	5,546.	7,210.
	84"	15"	33"	<b>ROCH OCDHP841</b> ( ) ( ) ( ) ( ) ( ) ( )	3,834.	4,217.	4,409.	4,601.	5,559.	5,393.	8,311.
	90"	15"	33"	<b>ROCH OCDHP901</b> ( ) ( ) ( ) ( ) ( ) ( )	3,897.	4,286.	4,481.	4,676.	5,650.	6,498.	8,447.
	96"	15"	33"	<b>ROCH OCDHP961</b> ( ) ( ) ( ) ( ) ( ) ( )	3,952.	4,347.	4,545.	4,742.	5,730.	6,590.	8,567.

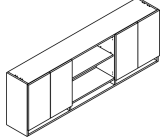

Order Code	Specification Information	Application Notes
Example: <b>ROCH OCDHP601</b> ( ) ( ) ( ) ( ) ( ) ( )	<i>To order please specify:</i>	These products are Glue and Dowel Construction
<b>R</b> Reff	1. Case Finish: L = Laminate	Letter depth is 15" nominal.
<b>O</b> Overhead	1 = V1	Fascias ordered separately
<b>C</b> Cabinet Hung	2 = V2	Tasklights not included
<b>HOC</b> Hinge door / open / cubby	3 = V3	Tack/Task panel order separately
<b>DH</b> Double High	2. Front Finish: L = Laminate	Unfinished backs
<b>P</b> Planning	1 = V1	Doors project below shelf for opening
<b>30</b> Width	2 = V2	No pull options
<b>1</b> Depth (letter)	3 = V3	Installation instruction sheets available on line.
<b>2</b> Case finish type	3. Lock option: N=no drilling, L=locking (wood or laminate doors only)	For Cabinet hung overheads, refer to part number 6TP00080.
<b>2</b> Front finish type	4. Lock finish: B=Black, S=Matte silver	
<b>L</b> Lock option	5. Case finish: V316	
<b>B</b> Lock finish	6. Front finish: V316	
<b>V316</b> Case finish		
<b>V316</b> Front finish		

dimensions noted nominal

Overhead, 28<sup>3</sup>/<sub>8</sub>" planning  
 Double high  
 Cabinet hung with glass doors, open  
 Cubby exposed

description	w	d	h	pattern no.	L	V1	V2	V3
Cabinet Hung overhead cabinet	60"	15"	33"	<b>ROCGHOC</b> DHP601()	\$4,024.	\$5,030.	\$5,784.	\$7,520.
glass hinge door / open /	66"	15"	33"	<b>ROCGHOC</b> DHP661()	4,127.	5,159.	5,933.	7,713.
cubby exposed	72"	15"	33"	<b>ROCGHOC</b> DHP721()	4,221.	5,277.	6,068.	7,889.
	78"	15"	33"	<b>ROCGHOC</b> DHP781()	4,316.	5,397.	6,204.	8,065.
	84"	15"	33"	<b>ROCGHOC</b> DHP841()	5,208.	6,406.	7,366.	9,576.
	90"	15"	33"	<b>ROCGHOC</b> DHP901()	5,287.	6,503.	7,478.	9,722.
	96"	15"	33"	<b>ROCGHOC</b> DHP961()	5,402.	6,645.	7,642.	9,934.

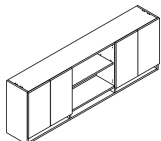

Order Code	Specification Information	Application Notes	
Example: <b>ROCGHOC</b> DHP601 () <td> <td><i>To order please specify:</i></td> <td>These products are Glue and Dowel Construction</td> </td>	<td><i>To order please specify:</i></td> <td>These products are Glue and Dowel Construction</td>	<i>To order please specify:</i>	These products are Glue and Dowel Construction
<b>R</b> Reff	1. Case Finish: L = Laminate 1 = V1 2 = V2 3 = V3	Letter depth is 15" nominal.	
<b>O</b> Overhead		Fascias ordered separately	
<b>C</b> Cabinet Hung		Tasklights not included	
<b>GHOC</b> Glass hinge door / open / cubby	2. Front Finish: L = Laminate 1 = V1 2 = V2 3 = V3	Tack/Task panel order separately	
<b>DH</b> Double High		Unfinished backs	
<b>P</b> Planning		Doors project below shelf for opening	
<b>60</b> Width	3. Lock option: N=no drilling, L=locking (wood or laminate doors only)	No pull options	
<b>1</b> Depth (letter)	4. Lock finish: B=Black, S=Matte silver	Installation instruction sheets available on line.	
	5. Case finish: V316	For Cabinet hung overheads, refer to part number 6TP00080.	
	6. Front finish: V316		

dimensions noted nominal

Overhead storage

Reuter overhead cabinet  
*Morrison panel mounted*  
*Designed by Robert Reuter*

description	type	w	d	h	pattern no.	black	P1	P2	P3	V1
Enclosed cabinet, with lock (Morrison panel brackets) - One door		24"	14 1/4"	14 3/4"	<b>RO3-M24( ) ( )L</b>		\$679.	\$679.	\$712.	\$1,019.
		30"	14 1/4"	14 3/4"	<b>RO3-M30( ) ( )L</b>		759.	759.	794.	1,097.
		36"	14 1/4"	14 3/4"	<b>RO3-M36( ) ( )L</b>		875.	875.	917.	1,228.
		42"	14 1/4"	14 3/4"	<b>RO3-M42( ) ( )L</b>		1,011.	1,011.	1,059.	1,363.
		48"	14 1/4"	14 3/4"	<b>RO3-M48( ) ( )L</b>		1,124.	1,124.	1,181.	1,493.

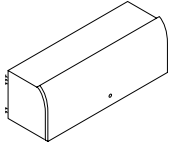

Enclosed cabinet, with lock (Morrison panel brackets) - Two doors		60"	14 1/4"	14 3/4"	<b>RO3-M60( ) ( )L</b>		1,426.	1,426.	1,494.	2,053.
		66"	14 1/4"	14 3/4"	<b>RO3-M66( ) ( )L</b>		1,551.	1,551.	1,632.	2,200.
		72"	14 1/4"	14 3/4"	<b>RO3-M72( ) ( )L</b>		1,661.	1,661.	1,744.	2,320.

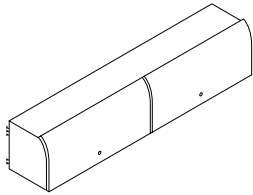

Enclosed cabinet, no lock (Morrison panel brackets) - One door		24"	14 1/4"	14 3/4"	<b>RO3-M24( ) ( )N</b>		614.	614.	644.	
		30"	14 1/4"	14 3/4"	<b>RO3-M30( ) ( )N</b>		694.	694.	729.	
		36"	14 1/4"	14 3/4"	<b>RO3-M36( ) ( )N</b>		811.	811.	849.	
		42"	14 1/4"	14 3/4"	<b>RO3-M42( ) ( )N</b>		945.	945.	991.	
		48"	14 1/4"	14 3/4"	<b>RO3-M48( ) ( )N</b>		1,058.	1,058.	1,112.	

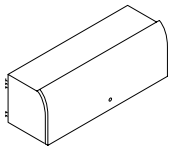

**Order Code**

Example:	<b>RO3-M48-612-M-L</b>
<b>RO3</b>	Reuter overhead cabinet
<b>M</b>	Morrison panel mounted
<b>48</b>	Width
<b>612</b>	Case finish
<b>M</b>	Front finish
<b>L</b>	With lock

**Specification Information**

First suffix is for case, second is door finish.  
*Specify finish for case and door:*  
 Interior partitions are black painted steel finish.

**Application Notes**

Reuter storage is a universal product applicable on Morrison or other Knoll systems. Overhead cabinets may be mounted on any combination of vertical panels the same width or up to 12" less than cabinet width. Cabinet door rotates above cabinet on side pivots, counterbalanced by two pneumatic cylinders. Two door cabinets have center divider and four pneumatic cylinders.

Reuter overheads may be mounted on other Knoll systems, cantilevered above 42" or 56" Morrison panels, or wall-mounted.

Vertical interior partitions may be positioned on 1 1/2" increments of width anywhere across shelf, 1 1/2" in from each side. Vertical partitions contain cutouts for mounting five horizontal partitions at 2" increments on either or both sides. Horizontals are suspended between two verticals, and may be positioned end-to-end in any combination up to 3" less than cabinet width. Available in sets of 10; 6", 9", 12", 15" widths.

Ganging bracket (page 396) joins adjacent overheads or shelves for additional stiffness and alignment.

Order locks for overheads with a KnollKey order form. Please note that Reuter overhead cabinets 60"W or wider require two lock cores.

Reuter overhead doors without locks include black, Knoll-logo insert, in the same position.

Insert may be removed to retrofit a lock later.

Reuter overhead cabinet  
*Morrison panel mounted*  
*Designed by Robert Reuter*

description	type	w	d	h	pattern no.	black	P1	P2	P3	V1
Enclosed cabinet, no lock (Morrison panel brackets) - Two doors		60"	14 <sup>3</sup> / <sub>4</sub> "	14 <sup>3</sup> / <sub>4</sub> "	<b>RO3-M60( ) (JN)</b>		\$1,292.	\$1,292.	\$1,356.	n/a
		66"	14 <sup>3</sup> / <sub>4</sub> "	14 <sup>3</sup> / <sub>4</sub> "	<b>RO3-M66( ) (JN)</b>		1,423.	1,423.	1,490.	n/a
		72"	14 <sup>3</sup> / <sub>4</sub> "	14 <sup>3</sup> / <sub>4</sub> "	<b>RO3-M72( ) (JN)</b>		1,526.	1,526.	1,605.	n/a

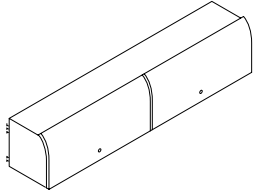

description	type	w	d	h	pattern no.	black
Interior partitions	Horizontal, set of 10	6"	11"	-	<b>RO1-HP6</b>	130.
	Horizontal, set of 10	9"	11"	-	<b>RO1-HP9</b>	164.
	Horizontal, set of 10	12"	11"	-	<b>RO1-HP12</b>	195.
	Horizontal, set of 10	15"	11"	-	<b>RO1-HP15</b>	227.
	Vertical, set of 5	-	11"	12"	<b>RO3-VP</b>	84.



**Order Code**

Example:	<b>RO3-M48-612-M-L</b>
<b>RO3</b>	Reuter overhead cabinet
<b>M</b>	Morrison panel mounted
<b>48</b>	Width
<b>612</b>	Case finish
<b>M</b>	Front finish
<b>L</b>	With lock

**Specification Information**

First suffix is for case, second is door finish.  
*Specify finish for case and door:*  
 Interior partitions are black painted steel finish.

**Application Notes**

Reuter storage is a universal product applicable on Morrison or other Knoll systems. Overhead cabinets may be mounted on any combination of vertical panels the same width or up to 12" less than cabinet width. Cabinet door rotates above cabinet on side pivots, counterbalanced by two pneumatic cylinders. Two door cabinets have center divider and four pneumatic cylinders.

Reuter overheads may be mounted on other Knoll systems, cantilevered above 42" or 56" Morrison panels, or wall-mounted.

Vertical interior partitions may be positioned on 1<sup>1</sup>/<sub>2</sub>" increments of width anywhere across shelf, 1<sup>1</sup>/<sub>2</sub>" in from each side. Vertical partitions contain cutouts for mounting five horizontal partitions at 2" increments on either or both sides. Horizontals are suspended between two verticals, and may be positioned end-to-end in any combination up to 3" less than cabinet width. Available in sets of 10; 6", 9", 12", 15" widths.

Ganging bracket (page 396) joins adjacent overheads or shelves for additional stiffness and alignment.

Order locks for overheads with a KnollKey order form. Please note that Reuter overhead cabinets 60"W or wider require two lock cores.

Reuter overhead doors without locks include black, Knoll-logo insert, in the same position.

Insert may be removed to retrofit a lock later.

Reuter overhead cabinet  
*desk, wall, or other Knoll system mounted*  
*Designed by Robert Reuter*

description	type	w	d	h	pattern no.	P1	P2	P3	V1
Enclosed cabinet, with lock (no mounting hardware) - One door		24"	14 1/4"	14 3/4"	<b>RO3-N24( ) ( )L</b>	\$666.	\$666.	\$698.	\$1,002.
		30"	14 1/4"	14 3/4"	<b>RO3-N30( ) ( )L</b>	741.	741.	781.	1,082.
		36"	14 1/4"	14 3/4"	<b>RO3-N36( ) ( )L</b>	857.	857.	901.	1,213.
		42"	14 1/4"	14 3/4"	<b>RO3-N42( ) ( )L</b>	994.	994.	1,046.	1,349.
		48"	14 1/4"	14 3/4"	<b>RO3-N48( ) ( )L</b>	1,112.	1,112.	1,165.	1,481.

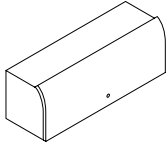

Enclosed cabinet, with lock (no mounting hardware) - Two doors		60"	14 1/4"	14 3/4"	<b>RO3-N60( ) ( )L</b>	1,406.	1,406.	1,479.	2,040.
		66"	14 1/4"	14 3/4"	<b>RO3-N66( ) ( )L</b>	1,540.	1,540.	1,613.	2,186.
		72"	14 1/4"	14 3/4"	<b>RO3-N72( ) ( )L</b>	1,644.	1,644.	1,726.	2,307.

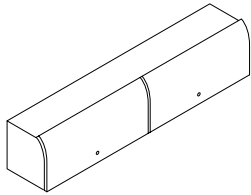

Enclosed cabinet, no lock (no mounting hardware) - One door		24"	14 1/4"	14 3/4"	<b>RO3-N24( ) ( )N</b>	598.	598.	627.	n/a
		30"	14 1/4"	14 3/4"	<b>RO3-N30( ) ( )N</b>	678.	678.	711.	n/a
		36"	14 1/4"	14 3/4"	<b>RO3-N36( ) ( )N</b>	792.	792.	832.	n/a
		42"	14 1/4"	14 3/4"	<b>RO3-N42( ) ( )N</b>	930.	930.	977.	n/a
		48"	14 1/4"	14 3/4"	<b>RO3-N48( ) ( )N</b>	1,044.	1,044.	1,097.	n/a

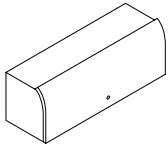

Enclosed cabinet, no lock (no mounting hardware) - Two doors		60"	14 1/4"	14 3/4"	<b>RO3-N60( ) ( )N</b>	1,275.	1,275.	1,340.	n/a
		66"	14 1/4"	14 3/4"	<b>RO3-N66( ) ( )N</b>	1,405.	1,405.	1,476.	n/a
		72"	14 1/4"	14 3/4"	<b>RO3-N72( ) ( )N</b>	1,516.	1,516.	1,591.	n/a

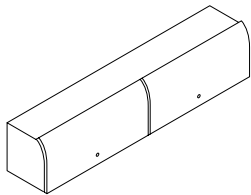

**Order Code**

Example:	<b>RO3-N48-613-613-L</b>
<b>RO3</b>	Reuter overhead cabinet
<b>N</b>	No brackets
<b>48</b>	Width
<b>613</b>	Case finish
<b>613</b>	Front finish
<b>L</b>	With lock

**Specification Information**

*Specify finish for case and door.*

**Application Notes**

Reuter storage is a universal product applicable on Knoll systems.

Cabinet door rotates above cabinet on side pivots, counterbalanced by two pneumatic cylinders. Two-door cabinets have center divider and four pneumatic cylinders. Vertical interior partitions may be positioned on 1 1/2" increments of width anywhere across shelf, 1 1/2" in from each side. Vertical partitions contain cutouts for mounting up to five horizontal partitions at 2" increments on either or both sides.

Horizontals are suspended between two verticals, and may be positioned end-to-end in any combination up to 3" less than cabinet width. Available in sets of 10; 6", 9", 12", 15" widths.



Order locks for overheads with a KnollKey order form. Please note that Reuter overhead cabinets 60"W or wider require two lock cores.

Reuter overhead doors without locks include black, Knoll-logo insert, in the same position. Insert may be removed to retrofit a lock later.

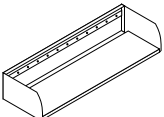

# Reuter open shelf

*Designed by Robert Reuter*

description	type	w	d	h	pattern no.	black	P1	P2	P3
 Open shelf no mounting hardware		30"	13"	8"	<b>RS1-N30( )</b>		\$318.	\$318.	\$333.
		36"	13"	8"	<b>RS1-N36( )</b>		360.	360.	378.
		42"	13"	8"	<b>RS1-N42( )</b>		388.	388.	407.
		48"	13"	8"	<b>RS1-N48( )</b>		417.	417.	438.
		60"	13"	8"	<b>RS1-N60( )</b>		489.	489.	515.
 Interior partitions	Vertical, set of 5	–	12"	6"	<b>RS1-VP</b>	79.			
	Horizontal, set of 10	6"	12"	–	<b>RO1-HP6</b>	130.			
		9"	12"	–	<b>RO1-HP9</b>	164.			
		12"	12"	–	<b>RO1-HP12</b>	195.			
		15"	12"	–	<b>RO1-HP15</b>	227.			

## Order Code

Example:	<b>RS1-N48-612</b>
<b>RS1</b>	Reuter shelf
<b>N</b>	No mounting hardware
<b>48</b>	Width
<b>612</b>	Finish

## Specification Information

*Specify paint finishes for shelf.*

## Application Notes

Interior partitions are black painted steel finish.



Reuter storage is a universal product applicable on Morrison or other Knoll systems.

Open shelves may be mounted on any combination of vertical panels the same width. Reuter open shelves may be Morrison Network desk-mounted, mounted on other Knoll systems, cantilevered above panels, or wall-mounted. Specify Reuter shelves with no mounting hardware, and brackets separately.

Vertical interior partitions may be positioned on 1 1/2" increments of width anywhere across shelf, 1 1/2" in from each side. Vertical partitions contain cutouts for mounting three horizontal partitions at 2" increments on either or both sides. Horizontals are suspended between two verticals, and may be positioned end-to-end in any combination up to 3" less than shelf width. Available in sets of 10; 6", 9", 12", 15" widths.

# Reuter open overhead

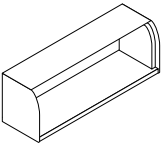
*Designed by Robert Reuter*

description	type	w	d	h	pattern no.	black	P1	P2	P3
 Open overhead no mounting hardware		30"	13"	14 <sup>3</sup> / <sub>4</sub> "	<b>RO3-ON30( )</b>	\$476.	\$476.	\$498.	
		36"	13"	14 <sup>3</sup> / <sub>4</sub> "	<b>RO3-ON36( )</b>	546.	546.	573.	
		42"	13"	14 <sup>3</sup> / <sub>4</sub> "	<b>RO3-ON42( )</b>	619.	619.	650.	
		48"	13"	14 <sup>3</sup> / <sub>4</sub> "	<b>RO3-ON48( )</b>	692.	692.	725.	
		60"	13"	14 <sup>3</sup> / <sub>4</sub> "	<b>RO3-ON60( )</b>	805.	805.	847.	
		72"	13"	14 <sup>3</sup> / <sub>4</sub> "	<b>RO3-ON72( )</b>	949.	949.	995.	
 Interior partitions	Vertical, set of 5	–	11"	12"	<b>RO3-VP</b>	84.			
	Horizontal, set of 10	6"	11"	–	<b>RO1-HP6</b>	130.			
		9"	11"	–	<b>RO1-HP9</b>	164.			
		12"	11"	–	<b>RO1-HP12</b>	195.			
		15"	11"	–	<b>RO1-HP15</b>	227.			

## Order Code

Example:	<b>RO3-ON30-612</b>
<b>RO3-O</b>	Reuter open overhead
<b>N</b>	No mounting hardware
<b>30</b>	Width
<b>612</b>	Finish

## Specification Information

*Specify finish for case and door.*

## Application Notes

Interior partitions are black painted steel finish.

Door retrofit kits convert an open overhead to an enclosed cabinet and include Reuter overhead door, left and right arm mechanisms, and lock or lock plug.

Reuter storage is a universal product applicable on Morrison or other Knoll systems. Open overheads may be mounted on any combination of vertical panels the same width or up to 12" less than shelf width.

Reuter open overheads may be desk-mounted, mounted on other Knoll systems, cantilevered above panels, or wall-mounted. Specify open overhead with no mounting hardware and brackets separately.

Vertical interior partitions may be positioned on 1 1/2" increments of width anywhere across shelf, 1 1/2" in from each side. Vertical partitions contain cutouts for mounting three horizontal partitions at 2" increments on either or both sides. Horizontals are suspended between two verticals, and may be positioned end-to-end in any combination up to 3" less than shelf width. Available in sets of 10; 6", 9", 12", 15" widths.

Reuter overhead storage  
*desk and panel mounting options*  
*Designed by Robert Reuter*

description	type	w	d	h	pattern no.	black	paint
Panel mount brackets, pair, overhead cabinet	For Reff System panels				<b>RO1-RPB</b>	\$44.	
<i>Note : Reff System panels require 2 pair for 60", 66" and 72" long Reuters.</i>							
Panel mount brackets, pair, open shelf	For Reff / AutoStrada panels				<b>RS1-RPB</b>	36.	
<i>Note : Reff System panels require 2 pair for 60", 66" and 72" long Reuters.</i>							
Upmount brackets	For Reff / AutoStrada panels				<b>RO1-RCB( )</b>		93.



Order Code	Specification Information	Application Notes
Example: <b>RO2-NS21-612</b>	<i>Specify paint finish for stanchions and upmount brackets.</i>	Reuter overhead cabinets and shelves may be mounted on Network desks or other Knoll systems, upmounted, or wall-mounted. Use bracket kits on this page with Reuter storage without mounting hardware.
<b>RO2</b> Reuter overhead	Panel mount brackets are painted black finish.	Specify stanchion outlets cover when planning PDC modules and/or power module in overhead support. See page for information on desktop power module.
<b>NS</b> Network stanchions		Upmount brackets support bottom of Reuter storage 1" or 2" above, or flush with top of corresponding width Morrison, Equity or Reff panel.
<b>21</b> Height		Overhead storage may be centered on, or mount to either side of Equity post. Note that full 6" modular width Reuter storage is wider than Equity centerline-width panel surrounds.
<b>612</b> Paint finish		For Morrison Network desk mount applications, overhead cabinet or shelf width must correspond to desk support width and worksurface with grommet. Stanchions bolt to desk support corner leg. Top of cabinet or stanchions aligns with adjacent 64"H vertical panels or vertical storage.
		Specify 22"H privacy screens (to 49"H) to enclose space between overhead and desk.

Reuter overhead storage  
*wall-mounting options and ADA pull*  
*Designed by Robert Reuter*

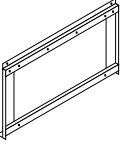
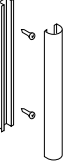
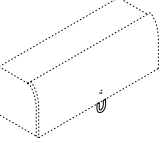
description	type	w	d	h	pattern no.	black
	24" or 30"W overheads	23"	1/2"	13"	<b>RO1-WMF2</b>	\$82.
	36" or 42"W overheads	35"	1/2"	13"	<b>RO1-WMF3</b>	88.
	48" or 60"W overheads	47"	1/2"	13"	<b>RO1-WMF4</b>	93.
Wall mount frames, shelf	24"W shelf	23"	1 1/2"	6"	<b>RS1-WMF24</b>	82.
	30"W shelf	29"	1 1/2"	6"	<b>RS1-WMF30</b>	86.
	36"W shelf	35"	1 1/2"	6"	<b>RS1-WMF36</b>	88.
	42"W shelf	41"	1 1/2"	6"	<b>RS1-WMF42</b>	91.
	48"W shelf	47"	1 1/2"	6"	<b>RS1-WMF48</b>	93.
	60"W shelf	59"	1 1/2"	6"	<b>RS1-WMF60</b>	99.
Wall mount wire manager, set of 10					<b>MWM-J</b>	146.
						
	Ganging bracket				<b>RO1-GB</b>	12.
ADA pull					<b>RO1-PULL</b>	48.
						

Order Code	Specification Information	Application Notes
Example: <b>RO1-GB</b>	Wall mount frames are painted black finish.	Wall mount frames secure Reuter overhead cabinet or shelf to wall (frame/wall mounting hardware is not included). Frame is concealed behind storage. Use two RO1-WMF2 to wall-mount 66"- and 72"-wide Reuter overheads.
<b>RO1</b> Reuter overhead	ADA pull is stainless steel.	Reuter open shelves 66" and 72"W are for stanchion support only.
<b>GB</b> Ganging bracket		Wall mount wire manager is two-part wire concealment kit, 22"H (medium grey only).
		Ganging bracket joins adjacent Reuter overheads or shelves for additional stiffness and alignment when storage is planned on only one side of a panel run.
		ADA pull mounts to Reuter painted front overhead door to allow seated users to close door easily. Specify one for each cabinet 24" - 48", two for cabinets 60" - 72".
		ADA pull cannot be mounted on wood front Reuter doors.

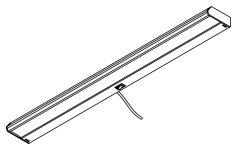
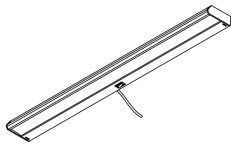
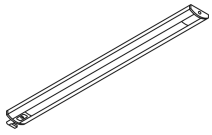
description	type	w	d	h	pattern no.	list
 <p>T5 Standard Task Light</p>	Use with 24" and wider overhead	19"	4"	1 1/2"	<b>RTAT5E19S</b>	\$218.
	Use with 30" and wider overhead	25"	4"	1 1/2"	<b>RTAT5E25S</b>	235.
	Use with 42" and wider overhead	37"	4"	1 1/2"	<b>RTAT5E37S</b>	253.
	Use with 60" and wider overhead	49"	4"	1 1/2"	<b>RTAT5E49S</b>	275.
	Use with 66" and wider overhead	61"	4"	1 1/2"	<b>RTAT5E61S</b>	292.
 <p>T5 Advanced Task Light</p>	Use with 30" and wider overhead	25"	4"	1 1/2"	<b>RTAT5E25A</b>	405.
	Use with 42" and wider overhead	37"	4"	1 1/2"	<b>RTAT5E37A</b>	426.
	Use with 60" and wider overhead	49"	4"	1 1/2"	<b>RTAT5E49A</b>	443.
	Use with 66" and wider overhead	61"	4"	1 1/2"	<b>RTAT5E61A</b>	461.
 <p>LED Task Light</p>	Use with 24" and wider overhead (3 LED's)	19"	2"	5/8"	<b>ML3L193M</b>	292.
	Use with 24" and wider overhead (6 LED's)	19"	2"	5/8"	<b>ML3L196M</b>	369.
	Use with 24" and wider overhead (9 LED's)	19"	2"	5/8"	<b>ML3L199M</b>	502.
	Use with 42" and wider overhead (6 LED's)	37"	2"	5/8"	<b>ML3L376M</b>	589.
	Use with 42" and wider overhead (12 LED's)	37"	2"	5/8"	<b>ML3L3712M</b>	666.
	Use with 42" and wider overhead (18 LED's)	37"	2"	5/8"	<b>ML3L3718M</b>	825.

Order Code	Specification Information	Application Notes
<b>T5 Standard Task Light</b>	<p><b>T5 Task Lights:</b> 120v and includes T5 cool white (4100K) fluorescent lamp, electronic ballast, 9' grounded cordset, prismatic lens, rocker switch, one cord exit management clip and mounting hardware. Housings are black.</p> <p><b>LED Task Lights:</b> Includes LED's, power supply with 12' cord and mounting hardware. Housings are clear anodized aluminum with grey color end-caps.</p>	<p><b>T5 Task Lights:</b> Specify suffix -CH and add \$45 list for City of Chicago installations. Example: DL3T5E25S-CH</p> <p>Cordset is center exit. On smaller units cord exit is off-center, but still not handed.</p> <p>T5 advanced task lights are fitted with ballasts and lamps compliant with LEED requirements, meeting the LEED EB standard for mercury content.</p> <p><b>LED Task Lights:</b> Power cord is able to attach to either end of fixture.</p> <p><b>Notes:</b> All task lights mount into the recess in the underside of overhead cabinets and shelves at least 6" wider than task light width.</p> <p>All task lights are TCLP compliant and meet requirements of California Title 20 and Title 24.</p>
Example: <b>RTAT5E25S</b>		
<b>RTA</b> Task Light		
<b>T5</b> T5 lamp		
<b>E</b> Electronic ballast		
<b>25</b> Width		
<b>S</b> Standard		
<b>LED Task Light</b>		
Example: <b>ML3L193M</b>		
<b>ML3</b> Task Light		
<b>L</b> LED		
<b>19</b> Width		
<b>3</b> # of LED's		
<b>M</b> Metal Overhead Attachment		

Progressive Overheads  
 28<sup>3</sup>/<sub>8</sub>" planning  
 Cabinet Hung with glass door

description	w	d	h	pattern no.	L	V1	V2	V3
Cabinet Hung Shelf	90"	15"	14 <sup>3</sup> / <sub>4</sub> "	<b>RROCGSD90GB()</b> ( ) ( )	\$2,935.	\$3,522.	\$4,050.	\$5,266.
Glass Sliding Doors Closed Ends	108"	15"	14 <sup>3</sup> / <sub>4</sub> "	<b>RROCGSD108GB()</b> ( ) ( )	3,211.	3,853.	4,431.	5,760.

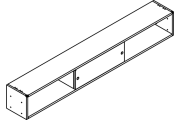

Cabinet Hung Shelf with Glass Sliding Door Right Hand	60"	15"	14 <sup>3</sup> / <sub>4</sub> "	<b>RROCGSDR60GB()</b> ( ) ( )	2,492.	2,866.	3,296.	4,284.
	72"	15"	14 <sup>3</sup> / <sub>4</sub> "	<b>RROCGSDR72GB()</b> ( ) ( )	2,674.	3,075.	3,537.	4,598.

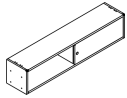

Cabinet Hung Shelf with Glass Sliding Door Left Hand	60"	15"	14 <sup>3</sup> / <sub>4</sub> "	<b>RROCGSDL60GB()</b> ( ) ( )	2,492.	2,866.	3,296.	4,284.
	72"	15"	14 <sup>3</sup> / <sub>4</sub> "	<b>RROCGSDL72GB()</b> ( ) ( )	2,674.	3,075.	3,537.	4,598.

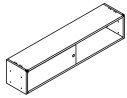

Order Code	Specification Information	Application Notes
Example: <b>RROCGSD90GB()</b> ( ) ( )	<i>To order please specify:</i>	These products are Glue and Dowel Construction.
<b>RR</b> Reffresh	1. Pull option=C Grommet pull	Above sizes are nominal.
<b>O</b> Overhead	2. Pull finish = Painted/plated	All sliding doors including wood, laminate and glass are non-locking.
<b>C</b> Cabinet Hung	3. Case finish = V316	Installation instruction sheets available on line.
<b>GSD</b> Glass Sliding Door	4. Door frame finish = Anodized / painted	For Cabinet hung overheads, refer to part number 6TP00080.
<b>90</b> 90" wide	5. Door Glass finish	For overhead with sliding doors, refer to part number 6TP00088.
<b>GB</b> Gable Both	GL11 = Black	
<b>G</b> Pull option	GL15 = Med. Grey	
<b>111</b> Pull finish	GL18 = White	
<b>V316</b> Case finish		
<b>AN</b> Door frame finish		
<b>GL11</b> Glass finish		

Progressive Overheads  
 28<sup>3</sup>/<sub>8</sub>" planning  
 Cabinet Hung with wood door

description	w	d	h	pattern no.	L/L	L/V1	L/V2	L/V3	V1/V1	V2/V2	V3/V3
Cabinet Hung Shelf with Wood/Laminate Sliding Door Right Hand	60"	15"	14 <sup>3</sup> / <sub>4</sub> "	<b>RROCWSDR60GB</b> ( ) ( ) ( ) ( ) ( ) ( )	\$2,123.	\$2,335.	\$2,441.	\$2,548.	\$2,654.	\$3,052.	\$3,967.
	72"	15"	14 <sup>3</sup> / <sub>4</sub> "	<b>RROCWSDR72GB</b> ( ) ( ) ( ) ( ) ( ) ( )	2,247.	2,472.	2,584.	2,679.	2,809.	3,230.	4,199.

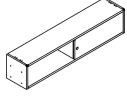

Cabinet Hung Shelf with Wood/Laminate Sliding Door Left Hand	60"	15"	14 <sup>3</sup> / <sub>4</sub> "	<b>RROCWSDL60GB</b> ( ) ( ) ( ) ( ) ( ) ( )	2,123.	2,335.	2,441.	2,548.	2,654.	3,052.	3,967.
	72"	15"	14 <sup>3</sup> / <sub>4</sub> "	<b>RROCWSDL72GB</b> ( ) ( ) ( ) ( ) ( ) ( )	2,247.	2,472.	2,584.	2,679.	2,809.	3,230.	4,199.

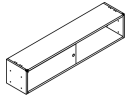

Cabinet Hung Shelf Sliding Doors Closed Ends	90"	15"	14 <sup>3</sup> / <sub>4</sub> "	<b>RROCWSD90GB</b> ( ) ( ) ( ) ( ) ( ) ( )	2,521.	2,774.	2,900.	3,026.	3,278.	3,769.	4,900.
	108"	15"	14 <sup>3</sup> / <sub>4</sub> "	<b>RROCWSD108GB</b> ( ) ( ) ( ) ( ) ( ) ( )	2,734.	3,007.	3,144.	3,281.	3,554.	4,087.	5,313.

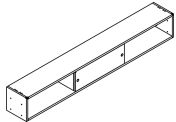

Order Code	Specification Information	Application Notes
Example: <b>RROCWSDR60GB</b>	To order please specify	These products are Glue and Dowel Construction.
<b>RR</b> Reff	1. Pull option: Grommet pull only	Above sizes are nominal.
<b>O</b> Overhead	2. Pull finish: Painted or Plated	All sliding doors including wood, laminate and glass are non-locking.
<b>C</b> Cabinet Hung	3. Case finish: L, V1, V2, V3	Installation instruction sheets available on line.
<b>WSDR</b> Wood/Lam. Sliding Door	4. Front finish: L, V1, V2, V3	For Cabinet hung overheads, refer to part number 6TP00080.
<b>60</b> 60" wide		For overhead with sliding doors, refer to part number 6TP00088.
<b>GB</b> Gable Both		
<b>G</b> Pull Option		
<b>115</b> Pull Finish		
<b>V316</b> Case Finish		
<b>V316</b> Front Finish		

All sliding doors including wood, laminate and glass are non-locking. Knoll does not assume any responsibility for the installation, attachment or the securing of wall hung units to the wall. A certified building contractor should be consulted. Please refer to wall mounting information on page 494.

Progressive Overheads  
 28<sup>3</sup>/<sub>8</sub>" planning  
 Cabinet Hung with open shelf

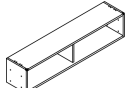
description	w	d	h	pattern no.	L	V1	V2	V3
Cabinet Hung <b>Open Shelf</b> Closed Ends 	60"	15"	14 <sup>3</sup> / <sub>4</sub> "	<b>RROCOS60GB</b> ( ) ( )	\$1,522.	\$1,978.	\$2,275.	\$2,957.
	72"	15"	14 <sup>3</sup> / <sub>4</sub> "	<b>RROCOS72GB</b> ( ) ( )	1,622.	2,109.	2,425.	3,153.
	90"	15"	14 <sup>3</sup> / <sub>4</sub> "	<b>RROCOS90GB</b> ( ) ( )	1,768.	2,299.	2,644.	3,437.
	108"	15"	14 <sup>3</sup> / <sub>4</sub> "	<b>RROCOS108GB</b> ( ) ( )	2,011.	2,615.	3,007.	3,909.

**Order Code**

Example: <b>RROCOS60GB</b> ( ) ( )
<b>RR</b> Reff
<b>O</b> Overhead
<b>C</b> Cabinet Hung
<b>OS</b> Open shelf
<b>60</b> 60" wide
<b>2</b> Finish type
<b>V316</b> Case Finish

**Specification Information**

To order please specify

- Finish type:  
 L = Laminate  
 1 = V1  
 2 = V2  
 3 = V3
- Finish

**Application Notes**

These products are Glue and Dowel Construction.  
 Above sizes are nominal.  
 Installation instruction sheets available on line.  
 For Cabinet hung overheads, refer to part number 6TP00080.



Progressive Overheads  
 28<sup>3</sup>/<sub>8</sub>" planning  
 Wall Hung with glass door

Reff Profiles

description	w	d	h	pattern no.	L	V1	V2	V3
Wall Hung Shelf with Glass Sliding Door	90"	15"	14 <sup>3</sup> / <sub>4</sub> "	<b>RROMGSD90GN</b> ( ) ( ) ( ) ( ) ( ) ( )	\$2,778.	\$3,334.	\$3,834.	\$4,984.
	108"	15"	14 <sup>3</sup> / <sub>4</sub> "	<b>RROMGSD108GN</b> ( ) ( ) ( ) ( ) ( ) ( )	3,151.	3,781.	4,349.	5,653.

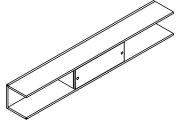

Wall Hung Shelf with Glass Sliding Door Gable Right	60"	15"	14 <sup>3</sup> / <sub>4</sub> "	<b>RROMGSD60GR</b> ( ) ( ) ( ) ( ) ( ) ( )	2,403.	2,883.	3,316.	4,311.
	72"	15"	14 <sup>3</sup> / <sub>4</sub> "	<b>RROMGSD72GR</b> ( ) ( ) ( ) ( ) ( ) ( )	2,647.	3,176.	3,653.	4,748.

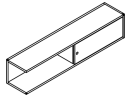

Wall Hung Shelf with Glass Sliding Door Gable Left	60"	15"	14 <sup>3</sup> / <sub>4</sub> "	<b>RROMGSD60GL</b> ( ) ( ) ( ) ( ) ( ) ( )	2,403.	2,883.	3,316.	4,311.
	72"	15"	14 <sup>3</sup> / <sub>4</sub> "	<b>RROMGSD72GL</b> ( ) ( ) ( ) ( ) ( ) ( )	2,647.	3,176.	3,653.	4,748.

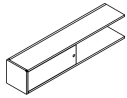

Order Code	Specification Information	Application Notes
Example: <b>RROMGSD90GN</b> ( )	To order please specify	These products are Glue and Dowel Construction.
<b>RR</b> Reff	1. Pull option: Grommet	Knoll does not assume any responsibility for the installation, attachment or the securing of wall hung units to the wall.
<b>O</b> Overhead	2. Pull finish: 115	Above sizes are nominal.
<b>M</b> Wall hung	3. Case finish: V319	Task lights and Fascias sold separately.
<b>GSD</b> Glass sliding door	4. Door frame: Anodized / painted	All sliding doors including wood, laminate and glass are non-locking.
<b>90</b> 90" wide	5. Glass finish:	Installation instruction sheets available on line.
<b>GN</b> No gable	GL11 = Black	For overheads with sliding doors, refer to part number 6TP00088.
<b>G</b> Pull Option	GL15 = Med. Grey	
<b>115</b> Pull Finish	GL18 = White	
<b>V319</b> Case Finish		
<b>AP</b> Door Frame Finish		
<b>GL11</b> Glass Finish		

28<sup>3/8</sup>" planning

Wall Hung with glass door closed ends

description	w	d	h	pattern no.	L	V1	V2	V3
Wall Hung Shelf with Glass Sliding Door	90"	15"	14 <sup>3/4</sup> "	<b>RROMGSD90GB()</b> ( )	\$3,110.	\$3,577.	\$4,113.	\$5,347.
	108"	15"	14 <sup>3/4</sup> "	<b>RROMGSD108GB()</b> ( )	3,493.	4,017.	4,619.	6,005.

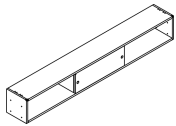

Wall Hung Shelf with Glass Sliding Door Right Hand	60"	15"	14 <sup>3/4</sup> "	<b>RROMGSDR60GB()</b> ( )	2,537.	2,917.	3,355.	4,361.
	72"	15"	14 <sup>3/4</sup> "	<b>RROMGSDR72GB()</b> ( )	2,751.	3,164.	3,638.	4,730.

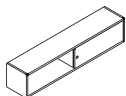

Wall Hung Shelf with Glass Sliding Door Left Hand	60"	15"	14 <sup>3/4</sup> "	<b>RROMGSDL60GB()</b> ( )	2,537.	2,917.	3,355.	4,361.
	72"	15"	14 <sup>3/4</sup> "	<b>RROMGSDL72GB()</b> ( )	2,751.	3,164.	3,638.	4,730.

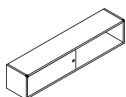

Order Code	Specification Information	Application Notes
Example: <b>RROMGSD90GN ( )</b>	To order please specify	These products are Glue and Dowel Construction.
<b>RR</b> Reff	1. Pull option: Grommet	Above sizes are nominal.
<b>O</b> Overhead	2. Pull finish: 115	Task lights and Fascias sold separately.
<b>M</b> Wall hung	3. Case finish: V319	All sliding doors including wood, laminate and glass are non-locking.
<b>GSD</b> Glass sliding door	4. Door frame: Anodized / painted	Installation instruction sheets available on line.
<b>90</b> 90" wide	5. Glass finish:	For overheads with sliding doors, refer to part number 6TP00088.
<b>GN</b> No gable	GL11 = Black	
<b>G</b> Pull Option	GL15 = Med. Grey	
<b>115</b> Pull Finish	GL18 = White	
<b>V319</b> Case Finish		
<b>AP</b> Door Frame Finish		
<b>GL11</b> Glass Finish		

Progressive Overheads  
 28<sup>3</sup>/<sub>8</sub>" planning  
 Wall Hung with wood door

description	w	d	h	pattern no.	L/L	L/V1	L/V2	L/V3	V1/V1	V2/V2	V3/V3
Wall Hung Shelf with Wood / Laminate Sliding Door	90"	15"	14 <sup>3</sup> / <sub>4</sub> "	<b>RROMWSD90GN</b> ( ) ( ) ( ) ( ) ( ) ( )	\$2,574.	\$2,832.	\$2,961.	\$3,089.	\$3,089.	\$3,553.	\$4,619.
	108"	15"	14 <sup>3</sup> / <sub>4</sub> "	<b>RROMWSD108GN</b> ( ) ( ) ( ) ( ) ( ) ( )	2,902.	3,192.	3,337.	3,482.	3,482.	4,006.	5,206.

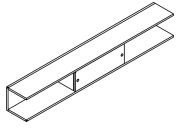

Wall Hung Shelf with Wood/Laminate Sliding Door Gable Right	60"	15"	14 <sup>3</sup> / <sub>4</sub> "	<b>RROMWSD60GR</b> ( ) ( ) ( ) ( ) ( ) ( )	2,211.	2,432.	2,543.	2,654.	2,654.	3,052.	3,967.
	72"	15"	14 <sup>3</sup> / <sub>4</sub> "	<b>RROMWSD72GR</b> ( ) ( ) ( ) ( ) ( ) ( )	2,409.	2,650.	2,771.	2,891.	2,891.	3,325.	4,322.

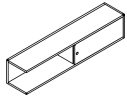

Wall Hung Shelf with Wood/Laminate Sliding Door Gable Left	60"	15"	14 <sup>3</sup> / <sub>4</sub> "	<b>RROMWSD60GL</b> ( ) ( ) ( ) ( ) ( ) ( )	2,211.	2,432.	2,543.	2,654.	2,654.	3,052.	3,967.
	72"	15"	14 <sup>3</sup> / <sub>4</sub> "	<b>RROMWSD72GL</b> ( ) ( ) ( ) ( ) ( ) ( )	2,409.	2,650.	2,771.	2,891.	2,891.	3,325.	4,322.

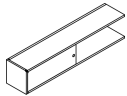

Wall Hung Shelf with Wood/Laminate Sliding Door Closed Ends	90"	15"	14 <sup>3</sup> / <sub>4</sub> "	<b>RROMWSD90GB</b> ( ) ( ) ( ) ( ) ( ) ( )	2,666.	2,933.	3,066.	3,199.	3,333.	3,832.	4,982.
	108"	15"	14 <sup>3</sup> / <sub>4</sub> "	<b>RROMWSD108GB</b> ( ) ( ) ( ) ( ) ( ) ( )	2,974.	3,272.	3,420.	3,569.	3,718.	4,275.	5,558.

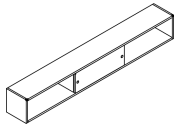

Order Code	Specification Information	Application Notes
Example: <b>RROMWSD90GB</b> ( ) ( ) ( ) ( ) ( ) ( )	To order please specify	These products are Glue and Dowel Construction.
<b>RR</b> Reff	1. Pull option: Grommet only	Above sizes are nominal.
<b>O</b> Overhead	2. Pull finish: Painted and Plated	Task lights and Fascias sold separately.
<b>M</b> Wall mount	3. Case finish: L, V1, V2, V3	No lock option at this time.
<b>WSD</b> Wood/Lam. Sliding Door	4. Door finish: L, V1, V2, V3	All sliding doors including wood, laminate and glass are non-locking.
<b>90</b> 90" wide		Installation instruction sheets available on line.
<b>GB</b> Gable both		For overheads with sliding doors, refer to part number 6TP00088.
<b>G</b> Pull Option		
<b>115</b> Pull Finish		
<b>V319</b> Case Finish		
<b>V319</b> Door Finish		

Knoll does not assume any responsibility for the installation, attachment or the securing of wall hung units to the wall. A certified building contractor should be consulted. Please refer to wall mounting information on page 494.

Progressive Overheads  
 28<sup>3</sup>/<sub>8</sub>" planning  
 Wall Hung with wood door

description	w	d	h	pattern no.	L/L	L/V1	L/V2	L/V3	V1/V1	V2/V2	V3/V3
Wall Hung Shelf with Wood/Laminate Sliding Door right Closed Ends	60"	15"	14 <sup>3</sup> / <sub>4</sub> "	<b>RROMWSDR60GB</b> ( ) ( ) ( ) ( ) ( ) ( )	\$2,149.	\$2,364.	\$2,472.	\$2,579.	\$2,686.	\$3,089.	\$4,016.
	72"	15"	14 <sup>3</sup> / <sub>4</sub> "	<b>RROMWSDR72GB</b> ( ) ( ) ( ) ( ) ( ) ( )	2,303.	2,533.	2,649.	2,764.	2,879.	3,311.	4,304.

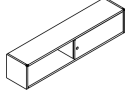

Wall Hung Shelf with Wood/Laminate Sliding Door left Closed Ends	60"	15"	14 <sup>3</sup> / <sub>4</sub> "	<b>RROMWSDL60GB</b> ( ) ( ) ( ) ( ) ( ) ( )	2,149.	2,364.	2,472.	2,579.	2,686.	3,089.	4,016.
	72"	15"	14 <sup>3</sup> / <sub>4</sub> "	<b>RROMWSDL72GB</b> ( ) ( ) ( ) ( ) ( ) ( )	2,303.	2,533.	2,649.	2,764.	2,879.	3,311.	4,304.

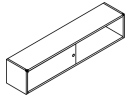

Order Code	Specification Information	Application Notes
Example: <b>RROMWSD90GB</b> ( ) ( ) ( ) ( ) ( ) ( )	To order please specify	These products are Glue and Dowel Construction.
<b>RR</b> Reff	1. Pull option: Grommet only	Above sizes are nominal.
<b>O</b> Overhead	2. Pull finish: Painted and Plated	Task lights and Fascias sold separately.
<b>M</b> Wall mount	3. Case finish: L, V1, V2, V3	No lock option at this time.
<b>WSD</b> Wood/Lam. Sliding Door	4. Door finish: L, V1, V2, V3	All sliding doors including wood, laminate and glass are non-locking.
<b>90</b> 90" wide		Installation instruction sheets available on line.
<b>GB</b> Gable both		For overheads with sliding doors, refer to part number 6TP00088.
<b>G</b> Pull Option		
<b>115</b> Pull Finish		
<b>V319</b> Case Finish		
<b>V319</b> Door Finish		

Progressive Overheads  
 28<sup>3</sup>/<sub>8</sub>" planning  
 Wall Hung L-Shelf

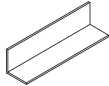
description	w	d	h	pattern no.	L	V1	V2	V3
L-Shelf	60"	15"	14 <sup>3</sup> / <sub>4</sub> "	<b>RRML60()</b> ( )	\$825.	\$990.	\$1,139.	\$1,481.
	72"	15"	14 <sup>3</sup> / <sub>4</sub> "	<b>RRML72()</b> ( )	917.	1,110.	1,265.	1,645.
	90"	15"	14 <sup>3</sup> / <sub>4</sub> "	<b>RRML90()</b> ( )	1,037.	1,245.	1,431.	1,861.
	108"	15"	14 <sup>3</sup> / <sub>4</sub> "	<b>RRML108()</b> ( )	1,187.	1,425.	1,639.	2,130.

**Order Code**

Example: <b>RRML60()</b> ( )
<b>RR</b> Reff Refresh
<b>M</b> Wall Hung
<b>L</b> L-Shelf
<b>60</b> 60" Wide
<b>L</b> Finish Type
<b>114</b> Finish

**Specification Information**

*To order please specify pattern number including:*

1. Finish type: L, V1, V2, V3
2. Finish = 114

**Application Notes**

These products are Glue and Dowel Construction

Shipped knocked down.

Hardware kit included.

Fascia sold separately.

Task light sold separately.

Installation instruction sheets available on line.

Installation instruction sheet, refer to part number 6TP00083

Knoll does not assume any responsibility for the installation, attachment or the securing of wall hung units to the wall.

A certified building contractor should be consulted.

Please refer to wall mounting information on page 494.

Progressive Overheads  
 28<sup>3/8</sup>" planning  
 Wall Hung Open Shelf

Reff Profiles

description	w	d	h	pattern no.	L	V1	V2	V3
Wall Hung Open Shelf Left Gable	60"	15"	14 <sup>3/4</sup> "	<b>RROMOS60GL( )</b>	\$1,640.	\$1,886.	\$2,169.	\$2,819.
	72"	15"	14 <sup>3/4</sup> "	<b>RROMOS72GL( )</b>	1,824.	2,098.	2,413.	3,137.

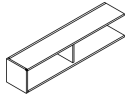

Wall Hung Open Shelf Right Gable	60"	15"	14 <sup>3/4</sup> "	<b>RROMOS60GR( )</b>	1,640.	1,886.	2,169.	2,819.
	72"	15"	14 <sup>3/4</sup> "	<b>RROMOS72GR( )</b>	1,824.	2,098.	2,413.	3,137.

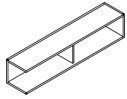

Wall Hung Open Shelf Closed Ends Left&Right Gable	60"	15"	14 <sup>3/4</sup> "	<b>RROMOS60GB( )( )</b>	1,562.	2,030.	2,335.	3,035.
	72"	15"	14 <sup>3/4</sup> "	<b>RROMOS72GB( )( )</b>	1,697.	2,207.	2,538.	3,299.
	90"	15"	14 <sup>3/4</sup> "	<b>RROMOS90GB( )( )</b>	1,998.	2,597.	2,987.	3,883.
	108"	15"	14 <sup>3/4</sup> "	<b>RROMOS108GB( )( )</b>	2,148.	2,792.	3,211.	4,174.

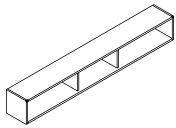

Wall Hung Open Shelf No Gable	90"	15"	14 <sup>3/4</sup> "	<b>RROMOS90GN( )</b>	2,076.	2,387.	2,745.	3,569.
	108"	15"	14 <sup>3/4</sup> "	<b>RROMOS108GN( )</b>	2,295.	2,639.	3,035.	3,945.

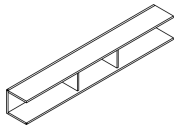

Example: <b>RROMOS60GL( )( )</b>
<b>RR</b> Reff
<b>O</b> Overhead
<b>M</b> Wall Hung
<b>OS</b> Open shelf
<b>60</b> 60" wide
<b>GL</b> Gable Left
<b>V316</b> Case Finish

To order please specify *pattern number including:*

1. Case finish:

These products are Glue and Dowel Construction.

Above sizes are nominal.

Sliding door is non-locking.

Knoll does not assume any responsibility for the installation, attachment or the securing of wall hung units to the wall. A certified building contractor should be consulted. Please refer to wall mounting information on page 494.

# Transaction tops for use with 42" H panel heights

description	w	d	t	pattern no.	L	M	V1	V2	V3
Transaction tops 1 1/4" Thick	24"	15"	1 1/4"	<b>RTTA24( )-( )</b>	\$323.	\$334.	\$334.	\$384.	\$519.
	30"	15"	1 1/4"	<b>RTTA30( )-( )</b>	353.	363.	363.	420.	567.
	36"	15"	1 1/4"	<b>RTTA36( )-( )</b>	384.	398.	398.	456.	618.
	42"	15"	1 1/4"	<b>RTTA42( )-( )</b>	416.	428.	428.	492.	663.
	48"	15"	1 1/4"	<b>RTTA48( )-( )</b>	443.	461.	461.	529.	714.
	54"	15"	1 1/4"	<b>RTTA54( )-( )</b>	474.	491.	491.	563.	760.
	60"	15"	1 1/4"	<b>RTTA60( )-( )</b>	505.	521.	521.	602.	813.
	66"	15"	1 1/4"	<b>RTTA66( )-( )</b>	536.	552.	552.	635.	857.
	72"	15"	1 1/4"	<b>RTTA72( )-( )</b>	564.	584.	584.	672.	907.

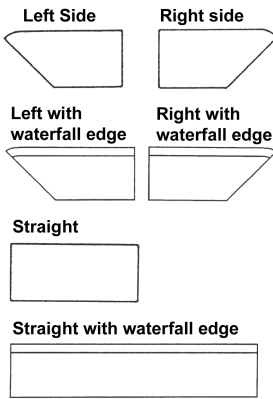
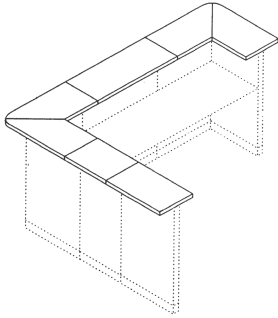

Transaction tops with 2" waterfall edge outside edge only, 1 1/4" Thick	24"	15"	1 1/4"	<b>RTTAWF24( )-( )</b>			667.	767.	1,036.
	30"	15"	1 1/4"	<b>RTTAWF30( )-( )</b>			731.	842.	1,137.
	36"	15"	1 1/4"	<b>RTTAWF36( )-( )</b>			792.	914.	1,233.
	42"	15"	1 1/4"	<b>RTTAWF42( )-( )</b>			854.	983.	1,326.
	48"	15"	1 1/4"	<b>RTTAWF48( )-( )</b>			920.	1,058.	1,428.
	54"	15"	1 1/4"	<b>RTTAWF54( )-( )</b>			981.	1,126.	1,520.
	60"	15"	1 1/4"	<b>RTTAWF60( )-( )</b>			1,045.	1,201.	1,622.
	66"	15"	1 1/4"	<b>RTTAWF66( )-( )</b>			1,105.	1,272.	1,717.
	72"	15"	1 1/4"	<b>RTTAWF72( )-( )</b>			1,169.	1,343.	1,813.

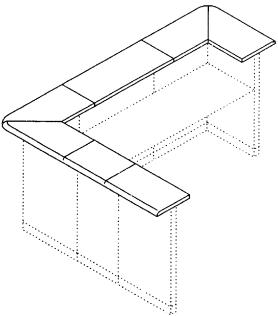

Not available in laminate or mixed finishes

Order Code	Specification Information	Application Notes
Example: <b>RTTA24S1</b>	<i>To order please specify pattern number including:</i>	Transaction tops are for mounting to 42" h panel or overall panel height achieved from 34" h base panel plus 8" h stacking module. Transaction tops ship with necessary bracketry included.
<b>R</b> Reff	1. End treatment type	Tops with waterfall edge cannot be specified with open pore finish. Available in V1 and V2 finishes only.
<b>TT</b> Transaction top	2. Finish type	Applicable finishes are listed on page 5 and 6.
<b>A</b> 1 1/4" thick	3. Finish	Product on this page will accept woodgrain laminate where laminate is currently an option. List price for woodgrain laminate options will be current published laminate list price plus 10%.
<b>24</b> 24" wide	<i>1. End treatment options:</i>	No grommets included.
<b>S</b> Straight end treatment	S = Straight	Tops may be used to span more than one consecutive panel.
<b>1</b> V1 finish	L = Left side mitre	Transaction tops will not fit between panel Hi-Lo conditions without notching the underside of the top. This can be done in the field or through Custom Product Development.
<b>Y311</b> Beech	R = Right side mitre	
	<i>2. Finish type:</i>	
	L = Laminate	
	M = Wood/laminate mixed	
	1 = V1	
	2 = V2	
	3 = V3	

# Transaction tops Brackets for Alternative Material

description	w	h	pattern no.	list
Attachment Bracketry			<b>RAMTB</b>	\$57.
			* Each panel need 2 brackets	
Foam Tape			<b>RAMTT</b>	22.
Transaction Top Bracket			<b>RAMTC24()</b>	42.
Cover			<b>RAMTC30()</b>	45.
			<b>RAMTC36()</b>	48.
			<b>RAMTC42()</b>	51.
			<b>RAMTC48()</b>	54.
			<b>RAMTC54()</b>	57.
			<b>RAMTC60()</b>	60.
			<b>RAMTC66()</b>	64.
			<b>RAMTC72()</b>	66.
Transaction Top Bracket			<b>RAMTCH24()</b>	57.
Cover Hilo			<b>RAMTCH30()</b>	60.
			<b>RAMTCH36()</b>	64.
			<b>RAMTCH42()</b>	67.
			<b>RAMTCH48()</b>	70.
			<b>RAMTCH54()</b>	73.
			<b>RAMTCH60()</b>	76.
			<b>RAMTCH66()</b>	79.
			<b>RAMTCH72()</b>	81.

Order Code	Specification Information	Application Notes
Example: <b>RAMTC</b>	<i>To order please specify pattern number including:</i>	Spline piece included in the right "R" hand pattern number.
<b>R</b> Reff		When a solid material is installed the "RAMTB" is required.
<b>A</b> Alternative	1. End treatment option	When a translucent material is installed ie. glass the "RAMTB" is also required in addition to the covers. The covers are intended to conceal the bracketry.
<b>M</b> Material	2. Finish type: Core paint finishes	
<b>T</b> Transaction Top		
<b>C</b> Cover		
<b>24</b> Width		
<b>L/R/M</b> Left/Right/Mitered		



# Gallery desk surrounds

## 1 1/4" worksurface

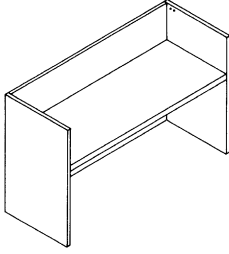
description	w	d	h	pattern no.	L	M/V1	V1	M/V2	V2	M/V3	V3
Freestanding top assembly surround (drilled to accept shelf) 	62"	25"	42"	<b>RGAF622-()</b>	\$1,329.	\$1,583.	\$1,583.	\$1,740.	\$1,822.	\$2,350.	\$2,460.
	68"	25"	42"	<b>RGAF682-()</b>	1,375.	1,640.	1,640.	1,802.	1,888.	2,431.	2,549.
	74"	25"	42"	<b>RGAF742-()</b>	1,426.	1,703.	1,703.	1,870.	1,957.	2,525.	2,640.
	80"	25"	42"	<b>RGAF802-()</b>	1,478.	1,758.	1,758.	1,929.	2,025.	2,605.	2,733.
	86"	25"	42"	<b>RGAF862-()</b>	1,523.	1,819.	1,819.	1,992.	2,092.	2,689.	2,824.
	92"	25"	42"	<b>RGAF922-()</b>	1,574.	1,879.	1,879.	2,056.	2,160.	2,775.	2,914.
	98"	25"	42"	<b>RGAF982-()</b>	1,624.	1,937.	1,937.	2,122.	2,230.	2,864.	3,010.
	62"	31"	42"	<b>RGAF623-()</b>	1,413.	1,684.	1,684.	1,846.	1,938.	2,492.	2,616.
	68"	31"	42"	<b>RGAF683-()</b>	1,467.	1,752.	1,752.	1,919.	2,015.	2,591.	2,721.
	74"	31"	42"	<b>RGAF743-()</b>	1,522.	1,818.	1,818.	1,992.	2,090.	2,689.	2,821.
	80"	31"	42"	<b>RGAF803-()</b>	1,578.	1,879.	1,879.	2,062.	2,164.	2,784.	2,921.
	86"	31"	42"	<b>RGAF863-()</b>	1,635.	1,949.	1,949.	2,135.	2,242.	2,883.	3,028.
	92"	31"	42"	<b>RGAF923-()</b>	1,689.	2,016.	2,016.	2,205.	2,317.	2,977.	3,128.
	98"	31"	42"	<b>RGAF983-()</b>	1,745.	2,081.	2,081.	2,281.	2,391.	3,080.	3,228.

If shelf is not ordered and no drillings are required, you must order through specials.

description	w	d	h	pattern no.	L	M/V1	V1	M/V2	V2	M/V3	V3
Shelf for above (uses keyhole) attachment hardware 	60"	12"	1"	<b>RGS60-()</b>	321.	n/a	383.	n/a	443.	n/a	598.
	66"	12"	1"	<b>RGS66-()</b>	333.	n/a	397.	n/a	456.	n/a	618.
	72"	12"	1"	<b>RGS72-()</b>	344.	n/a	411.	n/a	471.	n/a	636.
	78"	12"	1"	<b>RGS78-()</b>	354.	n/a	422.	n/a	487.	n/a	656.
	84"	12"	1"	<b>RGS84-()</b>	362.	n/a	436.	n/a	500.	n/a	675.
	90"	12"	1"	<b>RGS90-()</b>	375.	n/a	446.	n/a	513.	n/a	692.
	96"	12"	1"	<b>RGS96-()</b>	384.	n/a	457.	n/a	526.	n/a	712.

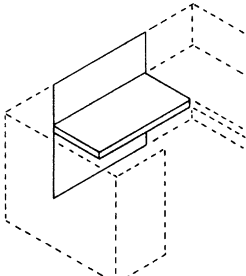
description	w	d	h	pattern no.	L	M/V1	V1	M/V2	V2	M/V3	V3
Bridge top assembly 	42"	21"	42"	<b>RGAB421-()</b>	758.	902.	902.	974.	1,037.	1,316.	1,399.
	48"	21"	42"	<b>RGAB481-()</b>	812.	965.	965.	1,040.	1,110.	1,404.	1,497.
	54"	21"	42"	<b>RGAB541-()</b>	864.	1,028.	1,028.	1,112.	1,183.	1,500.	1,597.
	60"	21"	42"	<b>RGAB601-()</b>	916.	1,091.	1,091.	1,183.	1,259.	1,597.	1,698.
	66"	21"	42"	<b>RGAB661-()</b>	970.	1,156.	1,156.	1,249.	1,330.	1,686.	1,794.
	72"	21"	42"	<b>RGAB721-()</b>	1,021.	1,217.	1,217.	1,319.	1,399.	1,781.	1,889.
	78"	21"	42"	<b>RGAB781-()</b>	1,071.	1,280.	1,280.	1,389.	1,472.	1,876.	1,987.
	84"	21"	42"	<b>RGAB841-()</b>	1,124.	1,339.	1,339.	1,450.	1,541.	1,957.	2,081.
	90"	21"	42"	<b>RGAB901-()</b>	1,174.	1,400.	1,400.	1,520.	1,611.	2,051.	2,176.
	96"	21"	42"	<b>RGAB961-()</b>	1,222.	1,458.	1,458.	1,582.	1,679.	2,136.	2,266.

Order Code	Specification Information	Application Notes
Example: <b>RGAF622NLL</b>		
<b>R</b> Reff		
<b>G</b> Gallery surround		
<b>A</b> 1 1/4" top thickness		
<b>F</b> Freestanding		
<b>62</b> 62" wide		
<b>2</b> 25" deep		
<b>N</b> No grommet		
<b>L</b> Finish type top, laminate		
<b>L</b> Finish type components		
<b>114</b> Folkstone grey (top)		
<b>114</b> Folkstone grey (components)		

**To order please specify pattern number including:**

- Grommet option
- Finish type, top
- Finish type, components
- Finish, top
- Finish, components

**1. Grommet options:**  
 N = No grommets  
 F = Flush front grommet

**2. Finish type, top:**  
 L = Laminate  
 M = Mixed (laminated top w/wood edge)  
 1 = V1  
 2 = V2  
 3 = V3

**3. Finish type, components:** (surround components)  
 L = Laminate  
 1 = V1  
 2 = V2  
 3 = V3

*If mixed top finish type, components must be type 1, 2 or 3; otherwise top and surround must be same finish.*

Product on this page will accept woodgrain laminate where laminate is currently an option.  
 List price for woodgrain laminate options will be current published laminate list price plus 10%.

1 1/4" tops require support at midpoint to reduce spans to 48" or less.

Hardware included.

Shipped knocked-down.

Gallery desk surrounds are available with waterfall edge as a standard special.

All requests for special grommet locations must be approved through custom product development.

All freestanding top assemblies are drilled to accept shelf.

M (mixed finish) includes laminate worksurface with wood edge and wood gallery surround.

**Specify only 26 1/2" h pedestals and support components as required when using with gallery desk surround products on this page.**

Applicable finishes are listed on page 5 and 6.

# Gallery desk surrounds

## right hand end assembly, 1 1/4" worksurface

Reff Profiles

description	d	w	h	pattern no.	L	M/V1	V1	M/V2	V2	M/V3	V3
Freestanding top assembly end for right hand application	21"	43"	42"	<b>RGAR431-</b> ( ) ( )	\$927.	\$1,106.	\$1,106.	\$1,206.	\$1,269.	\$1,628.	\$1,713.
		49"	42"	<b>RGAR491-</b> ( ) ( )	973.	1,162.	1,162.	1,269.	1,337.	1,713.	1,805.
		55"	42"	<b>RGAR551-</b> ( ) ( )	1,023.	1,218.	1,218.	1,332.	1,400.	1,798.	1,890.
		61"	42"	<b>RGAR611-</b> ( ) ( )	1,069.	1,274.	1,274.	1,391.	1,469.	1,878.	1,982.
		67"	42"	<b>RGAR671-</b> ( ) ( )	1,117.	1,335.	1,335.	1,456.	1,535.	1,964.	2,071.
		73"	42"	<b>RGAR731-</b> ( ) ( )	1,165.	1,389.	1,389.	1,518.	1,596.	2,048.	2,155.
		79"	42"	<b>RGAR791-</b> ( ) ( )	1,212.	1,444.	1,444.	1,581.	1,666.	2,134.	2,250.
		85"	42"	<b>RGAR851-</b> ( ) ( )	1,260.	1,503.	1,503.	1,639.	1,729.	2,212.	2,333.
		91"	42"	<b>RGAR911-</b> ( ) ( )	1,309.	1,562.	1,562.	1,704.	1,805.	2,302.	2,437.
		97"	42"	<b>RGAR971-</b> ( ) ( )	1,360.	1,619.	1,619.	1,765.	1,859.	2,382.	2,511.
25"	43"	42"	<b>RGAR432-</b> ( ) ( )	1,017.	1,212.	1,212.	1,326.	1,393.	1,789.	1,882.	
		49"	42"	<b>RGAR492-</b> ( ) ( )	1,062.	1,268.	1,268.	1,386.	1,457.	1,871.	1,966.
		55"	42"	<b>RGAR552-</b> ( ) ( )	1,111.	1,324.	1,324.	1,444.	1,525.	1,952.	2,059.
		61"	42"	<b>RGAR612-</b> ( ) ( )	1,160.	1,383.	1,383.	1,505.	1,588.	2,032.	2,142.
		67"	42"	<b>RGAR672-</b> ( ) ( )	1,207.	1,439.	1,439.	1,571.	1,653.	2,120.	2,233.
		73"	42"	<b>RGAR732-</b> ( ) ( )	1,255.	1,495.	1,495.	1,633.	1,721.	2,205.	2,325.
		79"	42"	<b>RGAR792-</b> ( ) ( )	1,300.	1,549.	1,549.	1,690.	1,785.	2,281.	2,410.
		85"	42"	<b>RGAR852-</b> ( ) ( )	1,348.	1,611.	1,611.	1,754.	1,852.	2,368.	2,499.
		91"	42"	<b>RGAR912-</b> ( ) ( )	1,399.	1,669.	1,669.	1,815.	1,918.	2,450.	2,589.
		97"	42"	<b>RGAR972-</b> ( ) ( )	1,449.	1,726.	1,726.	1,879.	1,985.	2,536.	2,680.
31"	43"	42"	<b>RGAR433-</b> ( ) ( )	1,081.	1,288.	1,288.	1,405.	1,481.	1,895.	1,999.	
		49"	42"	<b>RGAR493-</b> ( ) ( )	1,127.	1,342.	1,342.	1,467.	1,545.	1,980.	2,086.
		55"	42"	<b>RGAR553-</b> ( ) ( )	1,174.	1,400.	1,400.	1,523.	1,611.	2,056.	2,176.
		61"	42"	<b>RGAR613-</b> ( ) ( )	1,219.	1,456.	1,456.	1,582.	1,677.	2,136.	2,263.
		67"	42"	<b>RGAR673-</b> ( ) ( )	1,266.	1,514.	1,514.	1,644.	1,740.	2,219.	2,350.
		73"	42"	<b>RGAR733-</b> ( ) ( )	1,315.	1,570.	1,570.	1,705.	1,802.	2,303.	2,431.
		79"	42"	<b>RGAR793-</b> ( ) ( )	1,363.	1,623.	1,623.	1,765.	1,869.	2,382.	2,524.
		85"	42"	<b>RGAR853-</b> ( ) ( )	1,409.	1,681.	1,681.	1,828.	1,933.	2,467.	2,610.
		91"	42"	<b>RGAR913-</b> ( ) ( )	1,457.	1,738.	1,738.	1,887.	1,994.	2,547.	2,693.
		97"	42"	<b>RGAR973-</b> ( ) ( )	1,504.	1,791.	1,791.	1,949.	2,062.	2,631.	2,784.

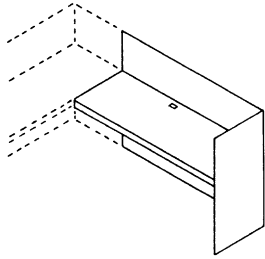

### Order Code

Example:	<b>RGAR431NLL</b>
<b>R</b>	Reff
<b>G</b>	Gallery surround
<b>A</b>	1 1/4" top thickness
<b>R</b>	Right hand return
<b>43</b>	43" wide
<b>1</b>	21" deep
<b>N</b>	No grommet
<b>L</b>	Finish type, top
<b>L</b>	Finish type, components

### Specification Information

To order please specify pattern number including:

- Grommet option
- Finish type top
- Finish type components
- Finish, top
- Finish, components

1. Grommet options:  
 N = No grommets  
 F = Flush front grommet

2. Finish type top:  
 L = Laminate  
 M = Wood/laminate mixed  
 1 = V1  
 2 = V2  
 3 = V3

### Application Notes

3. Finish type, surround:  
 L = Laminate  
 1 = V1  
 2 = V2  
 3 = V3

If mixed top finish type, components must be type 1,2 or 3; otherwise top and surround must be same finish.

Product on this page will accept woodgrain laminate where laminate is currently an option.  
 List price for woodgrain laminate options will be current published laminate list price plus 10%.

1 1/4" tops require support at mid point to reduce spans to 48" or less.

**Hardware included.**

**All requests for special grommet locations must be approved through custom product development.**

M (mixed finish) includes laminate worksurface, wood edge and wood surround.

**Specify only 26 1/2" h pedestals and support components as required when using gallery desk surround products on this page.**

Applicable finishes are listed on page 5 and 6.

# Gallery desk surrounds

## left hand end assembly, 1 1/4" worksurface

description	d	w	h	pattern no.	L	M/V1	V1	M/V2	V2	M/V3	V3
Freestanding top assembly end for left hand application	21"	43"	42"	<b>RGAL431-</b> ( ) ( )	\$927.	\$1,106.	\$1,106.	\$1,206.	\$1,269.	\$1,628.	\$1,713.
		49"	42"	<b>RGAL491-</b> ( ) ( )	973.	1,162.	1,162.	1,269.	1,337.	1,713.	1,805.
		55"	42"	<b>RGAL551-</b> ( ) ( )	1,023.	1,218.	1,218.	1,332.	1,400.	1,798.	1,890.
		61"	42"	<b>RGAL611-</b> ( ) ( )	1,069.	1,274.	1,274.	1,391.	1,469.	1,878.	1,982.
		67"	42"	<b>RGAL671-</b> ( ) ( )	1,117.	1,335.	1,335.	1,456.	1,535.	1,964.	2,071.
		73"	42"	<b>RGAL731-</b> ( ) ( )	1,165.	1,389.	1,389.	1,518.	1,596.	2,048.	2,155.
		79"	42"	<b>RGAL791-</b> ( ) ( )	1,212.	1,444.	1,444.	1,581.	1,666.	2,134.	2,250.
		85"	42"	<b>RGAL851-</b> ( ) ( )	1,260.	1,503.	1,503.	1,639.	1,729.	2,212.	2,333.
		91"	42"	<b>RGAL911-</b> ( ) ( )	1,309.	1,562.	1,562.	1,704.	1,805.	2,302.	2,437.
		97"	42"	<b>RGAL971-</b> ( ) ( )	1,360.	1,619.	1,619.	1,765.	1,859.	2,382.	2,511.
25"	43"	42"	<b>RGAL432-</b> ( ) ( )	1,017.	1,212.	1,212.	1,326.	1,393.	1,789.	1,882.	
		49"	42"	<b>RGAL492-</b> ( ) ( )	1,062.	1,268.	1,268.	1,386.	1,457.	1,871.	1,966.
		55"	42"	<b>RGAL552-</b> ( ) ( )	1,111.	1,324.	1,324.	1,444.	1,525.	1,952.	2,059.
		61"	42"	<b>RGAL612-</b> ( ) ( )	1,160.	1,383.	1,383.	1,505.	1,588.	2,032.	2,142.
		67"	42"	<b>RGAL672-</b> ( ) ( )	1,207.	1,439.	1,439.	1,571.	1,653.	2,120.	2,233.
		73"	42"	<b>RGAL732-</b> ( ) ( )	1,255.	1,495.	1,495.	1,633.	1,721.	2,205.	2,325.
		79"	42"	<b>RGAL792-</b> ( ) ( )	1,300.	1,549.	1,549.	1,690.	1,785.	2,281.	2,410.
		85"	42"	<b>RGAL852-</b> ( ) ( )	1,348.	1,611.	1,611.	1,754.	1,852.	2,368.	2,499.
		91"	42"	<b>RGAL912-</b> ( ) ( )	1,399.	1,669.	1,669.	1,815.	1,918.	2,450.	2,589.
		97"	42"	<b>RGAL972-</b> ( ) ( )	1,449.	1,726.	1,726.	1,879.	1,985.	2,536.	2,680.
31"	43"	42"	<b>RGAL433-</b> ( ) ( )	1,081.	1,288.	1,288.	1,405.	1,481.	1,895.	1,999.	
		49"	42"	<b>RGAL493-</b> ( ) ( )	1,127.	1,342.	1,342.	1,467.	1,545.	1,980.	2,086.
		55"	42"	<b>RGAL553-</b> ( ) ( )	1,174.	1,400.	1,400.	1,523.	1,611.	2,056.	2,176.
		61"	42"	<b>RGAL613-</b> ( ) ( )	1,219.	1,456.	1,456.	1,582.	1,677.	2,136.	2,263.
		67"	42"	<b>RGAL673-</b> ( ) ( )	1,266.	1,514.	1,514.	1,644.	1,740.	2,219.	2,350.
		73"	42"	<b>RGAL733-</b> ( ) ( )	1,315.	1,570.	1,570.	1,705.	1,802.	2,303.	2,431.
		79"	42"	<b>RGAL793-</b> ( ) ( )	1,363.	1,623.	1,623.	1,765.	1,869.	2,382.	2,524.
		85"	42"	<b>RGAL853-</b> ( ) ( )	1,409.	1,681.	1,681.	1,828.	1,933.	2,467.	2,610.
		91"	42"	<b>RGAL913-</b> ( ) ( )	1,457.	1,738.	1,738.	1,887.	1,994.	2,547.	2,693.
		97"	42"	<b>RGAL973-</b> ( ) ( )	1,504.	1,791.	1,791.	1,949.	2,062.	2,631.	2,784.

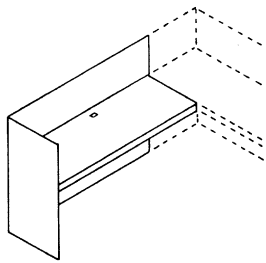

Order Code	Specification Information	Application Notes
Example: <b>RGAL431NLL</b>	<i>To order please specify pattern number including:</i>	<i>3. Finish type, surround:</i>
<b>R</b> Reff	1. Grommet option	L = Laminate
<b>G</b> Gallery surround	2. Finish type top	1 = V1
<b>A</b> 1 1/4" top thickness	3. Finish type components	2 = V2
<b>L</b> Left hand return	4. Finish, top	3 = V3
<b>43</b> 43" wide	5. Finish, components	<i>If mixed top finish type, components must be type 1,2 or 3; otherwise top and surround must be same finish.</i>
<b>1</b> 21" deep	<i>1. Grommet options:</i>	Product on this page will accept woodgrain laminate where laminate is currently an option.
<b>N</b> No grommet	N = No grommets	List price for woodgrain laminate options will be current published laminate list price plus 10%.
<b>L</b> Finish type, top	F = Flush front grommet	1 1/4" tops require support at mid point to reduce spans to 48" or less.
<b>L</b> Finish type, components		<b>Hardware included.</b>
	<i>2. Finish type top:</i>	Gallery desk surrounds are available with waterfall edge as a standard special.
	L = Laminate	<b>All requests for special grommet locations must be approved through custom product development.</b>
	M = Wood/laminate mixed	M (mixed finish) includes laminate worksurface, wood edge and wood surround.
	1 = V1	<b>Specify only 26 1/2" h pedestals and support components as required when using gallery desk surround products on this page.</b>
	2 = V2	Applicable finishes are listed on page 5 and 6.
	3 = V3	

# Gallery desk surrounds

## *gallery towers*

Reff Profiles

description	d	w	h	pattern no.	L	V1	V2	V3
Gallery Tower, left hand	32"	12"	46"	<b>RGTL4636</b> ( ) ( ) ( ) ( )	\$2,471.	\$3,051.	\$3,507.	\$4,735.

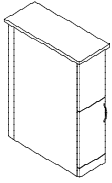

Actual depth of Gallery Tower is 32"

Gallery Tower, right hand	32"	12"	46"	<b>RGTR4636</b> ( ) ( ) ( ) ( )	2,471.	3,051.	3,507.	4,735.
---------------------------	-----	-----	-----	---------------------------------	--------	--------	--------	--------

Actual depth of Gallery Tower is 32"

### Order Code

Example:	<b>RGTL46362V319CL</b>
<b>R</b>	Reff
<b>GT</b>	Gallery Tower
<b>L</b>	Left hand
<b>46</b>	46" h
<b>36</b>	36" d
<b>2</b>	V2 finish type
<b>V319</b>	Medium Cherry
<b>C</b>	C-pull
<b>L</b>	Lock

### Specification Information

To order please specify pattern number including:

1. Finish type
2. Finish
3. Pull option
4. Pull finish (if applicable)
5. Lock option

1. *Finish type:*  
 L = Laminate  
 1 = V1  
 2 = V2  
 3 = V3

Applicable finishes are listed on page 5 and 6.

Product on this page will accept woodgrain laminate where laminate is currently an option. List price for woodgrain laminate options will be current published laminate list price plus 10%.

### 3. Pull options:

- D = Metal D-pull
- J = Routed J-pull
- C = Nickel finish C-pull (nickel finish only)
- S = Stainless steel finish S-pull (stainless steel finish only)

**Products on this page are engineered to align with 1-1/4" thick worksurfaces and 26-1/2" support components only. Gallery tower shelf will not align with 1-3/4" worksurfaces or 28 3/8" desk height products.**

### Application Notes

Gallery Tower ships with hookstrip to attach to 42" h Reff panel and angle bracket for 30" deep worksurface attachment at tower. .

Interior lower storage clearance: nominal 10.5" w x 22.5" h x 28.75" d

Overall depth includes top overhang, accommodates 30" d worksurfaces.

Gallery towers are to be used with panel applications.

Single pedestal desks  
27<sup>3</sup>/<sub>4</sub>" high overall  
available V2 finish options only

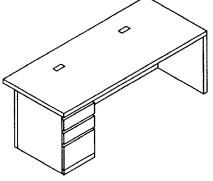
description	w	d	pattern no.	metal	metal	metal	wood	wood	wood
				interiors	interiors	interiors	interiors	interiors	interiors
				A	B	W	A	B	W
Single pedestal cantilevered desk, 30"d 	60"	30"	<b>RDSP6030J(A,B,W)( ) ( ) J2</b>	\$2,826.	\$3,234.	\$3,832.	\$2,987.	\$3,394.	\$3,990.
	72"	30"	<b>RDSP7230J(A,B,W)( ) ( ) J2</b>	2,939.	3,399.	3,990.	3,099.	3,559.	4,152.
	84"	30"	<b>RDSP8430J(A,B,W)( ) ( ) J2</b>	3,082.	3,590.	4,229.	3,243.	3,749.	4,388.
	96"	30"	<b>RDSP9630J(A,B,W)( ) ( ) J2</b>	3,207.	3,760.	4,449.	3,367.	3,920.	4,608.

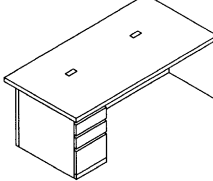
Single pedestal cantilevered desk, 36"d 	60"	36"	<b>RDSP6036J(A,B,W)( ) ( ) J2</b>	2,998.	3,430.	4,158.	3,230.	3,661.	4,389.
	72"	36"	<b>RDSP7236J(A,B,W)( ) ( ) J2</b>	3,136.	3,642.	4,375.	3,367.	3,873.	4,606.
	84"	36"	<b>RDSP8436J(A,B,W)( ) ( ) J2</b>	3,276.	3,867.	4,600.	3,507.	4,097.	4,830.
	96"	36"	<b>RDSP9636J(A,B,W)( ) ( ) J2</b>	3,401.	4,087.	4,814.	3,632.	4,317.	5,046.

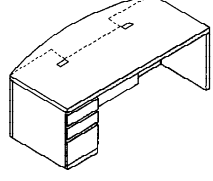
Single pedestal bow front desk with short modesty and false pedestal 	60"	30"	<b>RBSP6030J(A,B,W)( ) ( ) J2</b>	3,699.	3,963.	5,279.	3,930.	4,194.	5,509.
	72"	30"	<b>RBSP7230J(A,B,W)( ) ( ) J2</b>	3,826.	4,118.	5,573.	4,058.	4,348.	5,803.
	84"	30"	<b>RBSP8430J(A,B,W)( ) ( ) J2</b>	4,026.	4,344.	5,952.	4,257.	4,576.	6,182.
	96"	30"	<b>RBSP9630J(A,B,W)( ) ( ) J2</b>	4,209.	4,566.	6,349.	4,440.	4,799.	6,580.

Order Code	Specification Information	Application Notes
Example: <b>RDSP6030JAR2WJL</b>	<i>To order, please specify pattern number including:</i>	30"D rectilinear desk pedestals are 24"D including modesty panel.
<b>RD</b> Reff desk	1. Width	36"D rectilinear desk pedestals are 30"D including modesty panel.
<b>SP</b> Single pedestal	2. Depth	Pedestals are 16"W when calculating knee space subtract 16" per pedestal.
<b>60</b> 60" wide	3. File option	Bowed front desk pedestals are 30"D with finished backs.
<b>30</b> 30" deep	<i>J default = BBF</i>	All desks are non-handed.
<b>J</b> Box/box/file	4. Top thickness	All hardware included.
<b>A</b> 1 1/4" regular edge top	5. Grommet option	All waterfall desks have waterfall detail on front and back.
<b>R</b> Recessed grommets	6. Finish type	All components on this page available in V2 only.
<b>2</b> Finish type	7. Interior option	
<b>W</b> Wood interiors	8. Pull option	
<b>J</b> Routed pulls	9. Locking	
<b>L</b> Lock	<i>L default</i>	
	10. Veneer finish	
	11. Pull finish, when applicable	
	12. Grommet finish, when applicable	
	4. Thickness options:	
	A = 1 1/4"	
	B = 1 3/4"	
	W = 1 1/4" waterfall	
	5. Grommet Options:	
	R = Recessed grommets	
	N = No grommets	
	6. 2 = V2 Veneer Finish	
	7. Interior Options:	
	M = Metal	
	W = Wood	
	8. Pull Options:	
	D = Metal D-pull	
	J = Routed pull	
	C = Nickel C-pull (nickel finish only)	
	S = Stainless steel finish S-pull	
	Applicable finishes are listed on page 5 and 6.	
	Random locks are factory installed. Keyalike are field installed with the KnollKey order form.	

Double pedestal desks  
 27<sup>3</sup>/<sub>4</sub>" high overall  
 available V2 finish options only

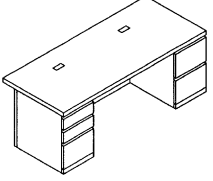
description	w	d	pattern no.	metal	metal	metal	wood	wood	wood
				interiors A	interiors B	interiors W	interiors A	interiors B	interiors W
	60"	30"	<b>RDDP6030JK(A,B,W)( ) ( ) 2</b>	\$3,648.	\$4,056.	\$4,653.	\$4,000.	\$4,408.	\$5,006.
	72"	30"	<b>RDDP7230JK(A,B,W)( ) ( ) 2</b>	3,762.	4,221.	4,813.	4,114.	4,574.	5,165.
	84"	30"	<b>RDDP8430JK(A,B,W)( ) ( ) 2</b>	3,905.	4,411.	5,050.	4,257.	4,762.	5,402.
	96"	30"	<b>RDDP9630JK(A,B,W)( ) ( ) 2</b>	4,030.	4,583.	5,270.	4,382.	4,935.	5,622.

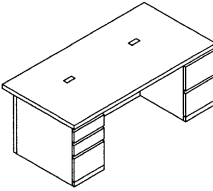
	60"	36"	<b>RDDP6036JK(A,B,W)( ) ( ) 2</b>	3,879.	4,309.	5,035.	4,353.	4,784.	5,512.
	72"	36"	<b>RDDP7236JK(A,B,W)( ) ( ) 2</b>	4,016.	4,521.	5,252.	4,490.	4,997.	5,729.
	84"	36"	<b>RDDP8436JK(A,B,W)( ) ( ) 2</b>	4,155.	4,744.	5,476.	4,630.	5,221.	5,952.
	96"	36"	<b>RDDP9636JK(A,B,W)( ) ( ) 2</b>	4,279.	4,964.	5,692.	4,755.	5,440.	6,168.

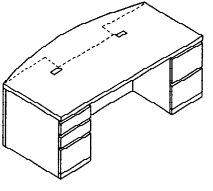
	60"	30"	<b>RBDP6030JK(A,B,W)( ) ( ) 2</b>	4,317.	4,582.	5,896.	4,794.	5,056.	6,372.
	72"	30"	<b>RBDP7230JK(A,B,W)( ) ( ) 2</b>	4,444.	4,735.	6,191.	4,918.	5,211.	6,665.
	84"	30"	<b>RBDP8430JK(A,B,W)( ) ( ) 2</b>	4,644.	4,962.	6,569.	5,119.	5,438.	7,045.
	96"	30"	<b>RBDP9630JK(A,B,W)( ) ( ) 2</b>	4,827.	5,185.	6,966.	5,303.	5,659.	7,441.

Order Code	Specification Information	Application Notes
Example: <b>RDDP7236JKAR2WJL</b>		
<b>RD</b> Reff desk	<i>To order, please specify pattern number including:</i>	5. <i>Grommet Options:</i> R = Recessed grommets N = No grommets
<b>DP</b> Double pedestal	1. Width	6. 2 = V2 Veneer Finish
<b>72</b> 72" wide	2. Depth	7. <i>Interior Options:</i> M = Metal W = Wood
<b>36</b> 36" deep	3. File option <i>JK default = BBF and FF</i>	8. <i>Pull Options:</i> D = Metal D-pull J = Routed pull C = Nickel C-pull (nickel finish only) S = Stainless steel finish S-pull
<b>J</b> Box/box/file pedestal	4. Top thickness	Applicable finishes are listed on page 5 and 6.
<b>K</b> File/file	5. Grommet option	Random locks are factory installed. Keyalike are field installed with the KnollKey order form.
<b>A</b> 1 1/4" Thick worksurface	6. Finish type	
<b>R</b> Recessed grommets	7. Interior option	
<b>2</b> Finish type, V2	8. Pull option	
<b>W</b> Wood interiors	9. Locking <i>L default</i>	
<b>J</b> Routed pull	10. Veneer finish	
<b>L</b> Lock	11. Pull finish, when applicable	
	12. Grommet finish, when applicable	
	4. <i>Thickness options:</i> A = 1 1/4" B = 1 3/4" W = 1 1/4" waterfall	

Desk returns  
 27<sup>3</sup>/<sub>4</sub>" high overall  
 available V2 finish options only

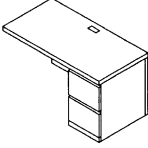
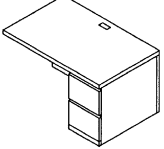
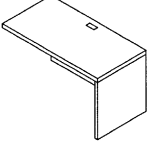
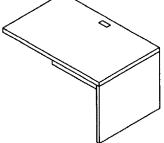
description	w	d	pattern no.	metal interiors A	metal interiors B	metal interiors W	wood interiors A	wood interiors B	wood interiors W
 Single pedestal return, 24"d	36"	24"	<b>RRSP3624K(A,B,W)( ) ( ) 2</b>	\$2,079.	\$2,405.	\$3,036.	\$2,272.	\$2,597.	\$3,229.
	42"	24"	<b>RRSP4224K(A,B,W)( ) ( ) 2</b>	2,132.	2,499.	3,117.	2,325.	2,690.	3,309.
	48"	24"	<b>RRSP4824K(A,B,W)( ) ( ) 2</b>	2,222.	2,615.	3,281.	2,413.	2,806.	3,473.
	54"	24"	<b>RRSP5424K(A,B,W)( ) ( ) 2</b>	2,281.	2,680.	3,412.	2,474.	2,872.	3,603.
	60"	24"	<b>RRSP6024K(A,B,W)( ) ( ) 2</b>	2,338.	2,739.	3,549.	2,531.	2,932.	3,742.
 Single pedestal return, 30"d	36"	30"	<b>RRSP3630K(A,B,W)( ) ( ) 2</b>	2,212.	2,575.	3,288.	2,457.	2,818.	3,530.
	42"	30"	<b>RRSP4230K(A,B,W)( ) ( ) 2</b>	2,272.	2,659.	3,387.	2,514.	2,902.	3,632.
	48"	30"	<b>RRSP4830K(A,B,W)( ) ( ) 2</b>	2,365.	2,760.	3,557.	2,609.	3,005.	3,803.
	54"	30"	<b>RRSP5430K(A,B,W)( ) ( ) 2</b>	2,436.	2,825.	3,725.	2,679.	3,070.	3,969.
	60"	30"	<b>RRSP6030K(A,B,W)( ) ( ) 2</b>	2,478.	2,883.	3,814.	2,722.	3,128.	4,060.
 End panel return	36"	24"	<b>RREP3624(A,B,W)(F,N)2</b>				1,258.	1,582.	2,215.
	42"	24"	<b>RREP4224(A,B,W)(F,N)2</b>				1,310.	1,677.	2,296.
	48"	24"	<b>RREP4824(A,B,W)(F,N)2</b>				1,399.	1,791.	2,459.
	54"	24"	<b>RREP5424(A,B,W)(F,N)2</b>				1,460.	1,858.	2,589.
	60"	24"	<b>RREP6024(A,B,W)(F,N)2</b>				1,517.	1,917.	2,727.
 End panel return	36"	30"	<b>RREP3630(A,B,W)(F,N)2</b>				1,336.	1,695.	2,408.
	42"	30"	<b>RREP4230(A,B,W)(F,N)2</b>				1,393.	1,780.	2,509.
	48"	30"	<b>RREP4830(A,B,W)(F,N)2</b>				1,487.	1,882.	2,680.
	54"	30"	<b>RREP5430(A,B,W)(F,N)2</b>				1,557.	1,946.	2,848.
	60"	30"	<b>RREP6030(A,B,W)(F,N)2</b>				1,598.	2,005.	2,936.

Preconfigured Refr Desking

Order Code	Specification Information	Application Notes
Example: <b>RREP4830AF2</b> <b>RREP</b> Reff desk return <b>48</b> 48" wide <b>30</b> 30" deep <b>A</b> 1 1/4" thick worksurface <b>F</b> Flush grommets <b>2</b> Finish type, V2	To order, please specify pattern number including: 1. Width 2. Depth 3. File option where applicable <i>K default = FF</i> 4. Top thickness 5. Grommet option 6. Finish type 7. Interior option where applicable 8. Pull option where applicable 9. Locking where applicable L default 10. Veneer finish 11. Pull finish, when applicable 12. Grommet finish, when applicable  4. Thickness options: A = 1 1/4" B = 1 3/4" W = 1 1/4" waterfall	5. Grommet Options: F = Flush grommets N = No grommets  6. 2 = V2 Veneer Finish  7. Interior Options: M = Metal W = Wood  8. Pull Options: D = Metal D-pull J = Routed pull C = Nickel C-pull (nickel finish only) S = Stainless steel finish S-pull  Applicable finishes are listed on page 5 and 6.
		Pedestals are 16"W when calculating knee space subtract 16" per pedestal.  All desks are non-handed.  All hardware included.  Desk returns with waterfall have waterfall edge 3 sides.  All components on this page available in V2 only.  Random locks are factory installed. Keyalike are field installed with the KnollKey order form.

Single pedestal credenzas  
 27<sup>3</sup>/<sub>4</sub>" high overall  
 available V2 finish options only

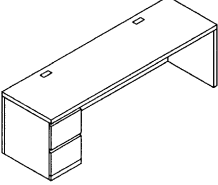
description	w	d	pattern no.	metal	metal	metal	wood	wood	wood
				interiors A	interiors B	interiors W	interiors A	interiors B	interiors W
Single pedestal credenza 	60"	24"	<b>RCSP6024K(A,B,W)( ) ( ) 2</b>	\$2,688.	\$3,088.	\$3,293.	\$2,880.	\$3,281.	\$3,484.
	72"	24"	<b>RCSP7224K(A,B,W)( ) ( ) 2</b>	2,821.	3,255.	3,474.	3,013.	3,447.	3,667.
	84"	24"	<b>RCSP8424K(A,B,W)( ) ( ) 2</b>	2,958.	3,445.	3,668.	3,151.	3,638.	3,861.
	96"	24"	<b>RCSP9624K(A,B,W)( ) ( ) 2</b>	3,081.	3,617.	3,855.	3,272.	3,810.	4,046.

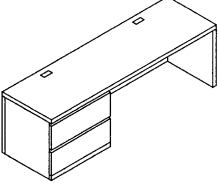
description	w	d	pattern no.	metal	metal	metal	wood	wood	wood
				interiors A	interiors B	interiors W	interiors A	interiors B	interiors W
Single lateral file credenza (30" wide lateral file) 	60"	24"	<b>RCS3L6024K(A,B,W)( ) ( ) 2</b>	2,834.	3,234.	3,439.	3,275.	3,675.	3,879.
	72"	24"	<b>RCS3L7224K(A,B,W)( ) ( ) 2</b>	2,967.	3,401.	3,620.	3,406.	3,842.	4,062.
	84"	24"	<b>RCS3L8424K(A,B,W)( ) ( ) 2</b>	3,104.	3,592.	3,814.	3,544.	4,031.	4,254.
	96"	24"	<b>RCS3L9624K(A,B,W)( ) ( ) 2</b>	3,226.	3,763.	4,002.	3,667.	4,203.	4,443.

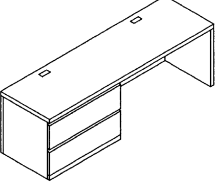
description	w	d	pattern no.	metal	metal	metal	wood	wood	wood
				interiors A	interiors B	interiors W	interiors A	interiors B	interiors W
Single lateral file credenza (36" wide lateral file) 	60"	24"	<b>RCS6L6024K(A,B,W)( ) ( ) 2</b>	2,914.	3,317.	3,520.	3,678.	4,079.	4,284.
	72"	24"	<b>RCS6L7224K(A,B,W)( ) ( ) 2</b>	3,048.	3,482.	3,703.	3,812.	4,246.	4,465.
	84"	24"	<b>RCS6L8424K(A,B,W)( ) ( ) 2</b>	3,185.	3,673.	3,895.	3,949.	4,436.	4,659.
	96"	24"	<b>RCS6L9624K(A,B,W)( ) ( ) 2</b>	3,307.	3,845.	4,082.	4,072.	4,608.	4,845.

Order Code	Specification Information	Application Notes
Example: <b>RCS6L9624KAF2MDL</b>	<i>To order, please specify pattern number including:</i>	<p>Pedestals are 16"W when calculating knee space subtract 16" per pedestal.</p> <p>Credenzas with lateral files or pedestals are non-handed.</p> <p>All hardware included.</p> <p>All waterfall credenzas have waterfall detail on front only.</p> <p>All components on this page available in V2 only.</p> <p>Applicable finishes are listed on page 5 and 6.</p> <p>Random locks are factory installed. Keyalike are field installed with the KnollKey order form.</p>
<b>RC</b> Reff credenza	5. Grommet Options: F = Flush grommets N = No grommets	
<b>S6L</b> Single 36" w lateral file	6. 2 = V2 Veneer Finish	
<b>96</b> 96" wide	7. Interior Options: M = Metal W = Wood	
<b>24</b> 24" wide	8. Pull Options: D = Metal D-pull J = Routed pull C = Nickel C-pull (nickel finish only) S = Stainless steel finish S-pull	
<b>K</b> File/file	9. Locking <i>L default</i>	
<b>A</b> 1 1/4" thick worksurface	10. Veneer finish	
<b>F</b> Flush grommets	11. Pull finish, when applicable	
<b>2</b> Finish type	12. Grommet finish, when applicable	
<b>M</b> metal interiors	4. Thickness options: A = 1 1/4" B = 1 3/4" W = 1 1/4" waterfall	
<b>D</b> D-metal pull		
<b>L</b> Lock		

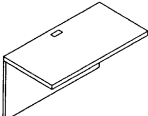

Bridge assemblies  
 27<sup>3</sup>/<sub>4</sub>" high overall  
 available V2 finish options only

description	w	d	pattern no.	A	B	W
Bridge assembly 	36"	24"	<b>RBR3624(A,B,W)(F,N)2</b>	\$900.	\$1,225.	\$1,859.
	42"	24"	<b>RBR4224(A,B,W)(F,N)2</b>	953.	1,320.	1,940.
	48"	24"	<b>RBR4824(A,B,W)(F,N)2</b>	1,043.	1,435.	2,102.
	36"	30"	<b>RBR3630(A,B,W)(F,N)2</b>	960.	1,320.	2,033.
	42"	30"	<b>RBR4230(A,B,W)(F,N)2</b>	1,016.	1,404.	2,134.
	48"	30"	<b>RBR4830(A,B,W)(F,N)2</b>	1,111.	1,507.	2,306.

Preconfigured Reff  
Deskings

Order Code	Specification Information	Application Notes
Example: <b>RBR4830WF2</b> <b>RBR</b> Reff bridge assembly <b>48</b> 48" wide <b>30</b> 30" deep <b>W</b> Waterfall edge 1 1/4" <b>F</b> Flush grommets <b>2</b> Conventional veneer	To order, please specify pattern number including: 1. Top thickness 2. Grommet option 3. Finish type 4. Veneer finish 5. Grommet color  1. Thickness options: A = 1 1/4" straight edge B = 1 3/4" straight edge W = 1 1/4" waterfall edge  2. Grommet Options: F = Flush grommets N = No grommets  3. 2 = V2 Veneer Finish	4. Grommet Color  Applicable finishes are listed on page 5 and 6.  Bridge assemblies are non-handed. All hardware included. Waterfall option on all 3 sides. Available in conventional veneer only. All components on this page are available in V2 only. Shipped with full height modesty.

Double pedestal credenzas  
 27<sup>3</sup>/<sub>4</sub>" high overall  
 available V2 finish options only

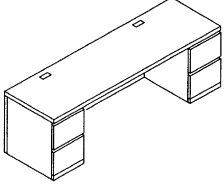
description	w	d	pattern no.	metal	metal	metal	wood	wood	wood
				interiors A	interiors B	interiors W	interiors A	interiors B	interiors W
	60"	24"	<b>RCDP6024K(A,B,W)( ) ( ) 2</b>	\$3,512.	\$3,910.	\$4,115.	\$3,894.	\$4,295.	\$4,500.
	72"	24"	<b>RCDP7224K(A,B,W)( ) ( ) 2</b>	3,642.	4,077.	4,296.	4,026.	4,462.	4,681.
	84"	24"	<b>RCDP8424K(A,B,W)( ) ( ) 2</b>	3,780.	4,268.	4,490.	4,164.	4,651.	4,874.
	96"	24"	<b>RCDP9624K(A,B,W)( ) ( ) 2</b>	3,902.	4,438.	4,678.	4,288.	4,822.	5,061.

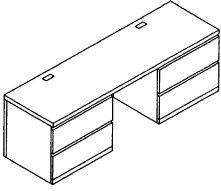
description	w	d	pattern no.	metal	metal	metal	wood	wood	wood
				interiors A	interiors B	interiors W	interiors A	interiors B	interiors W
	60"	24"	<b>RCD3L6024K(A,B,W)( ) ( ) 2</b>	3,802.	4,202.	4,408.	4,683.	5,084.	5,287.
	84"	24"	<b>RCD3L8424K(A,B,W)( ) ( ) 2</b>	4,073.	4,561.	4,783.	4,953.	5,440.	5,662.
	96"	24"	<b>RCD3L9624K(A,B,W)( ) ( ) 2</b>	4,196.	4,730.	4,969.	5,076.	5,611.	5,851.

96" w shown; 60" w has no knee space

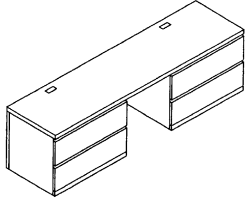
description	w	d	pattern no.	metal	metal	metal	wood	wood	wood
				interiors A	interiors B	interiors W	interiors A	interiors B	interiors W
	72"	24"	<b>RCD6L7224K(A,B,W)( ) ( ) 2</b>	4,097.	4,532.	4,752.	5,625.	6,058.	6,277.
	96"	24"	<b>RCD6L9624K(A,B,W)( ) ( ) 2</b>	4,357.	4,893.	5,132.	5,883.	6,419.	6,658.

96" w shown; 72" w has no knee space

Order Code	Specification Information	Application Notes
Example: <b>RCD6L9624KBF2WDL</b>	<i>To order, please specify pattern number including:</i>	Pedestals are 16"W when calculating knee space subtract 16" per pedestal.  All credenzas are non-handed.  All hardware included.  All waterfall credenzas have waterfall detail on front only.  All components on this page available in V2 only.  Shipped with full height modesty.  Applicable finishes are listed on page 5 and 6.  Random locks are factory installed. Keyalike are field installed with the KnollKey order form.
<b>RC</b> Reff credenza	1. Width	
<b>D6L</b> Double 36" w lateral file	2. Depth	
<b>96</b> 96" wide	3. File option	
<b>24</b> 24" wide	<i>K default = FF</i>	
<b>K</b> File file	4. Top thickness	
<b>B</b> 1 <sup>3</sup> / <sub>4</sub> " thick worksurface	5. Grommet option	
<b>F</b> Flush grommets	6. Finish type	
<b>2</b> Finish type	7. Interior option	
<b>W</b> wood drawer interior	8. Pull option	
<b>D</b> D-metal pull	9. Locking	
<b>L</b> Lock	<i>L default</i>	
	10. Veneer finish	
	11. Pull finish, when applicable	
	12. Grommet finish, when applicable	
	4. Thickness options: A = 1 <sup>1</sup> / <sub>4</sub> " B = 1 <sup>3</sup> / <sub>4</sub> " W = 1 <sup>1</sup> / <sub>4</sub> " waterfall	
	5. Grommet Options: F = Flush grommets N = No grommets	
	6. 2 = V2 Veneer Finish	
	7. Interior Options: M = Metal W = Wood	
	8. Pull Options: D = Metal D-pull J = Routed pull C = Nickel C-pull (nickel finish only) S = Stainless steel finish S-pull	

# Accessories

## *hookstrips and top caps*

Reff Profiles

description	w	pattern no.	list price
Panel hookstrips	8"	<b>R2HK0008</b>	\$42.
	15"	<b>R2HK0015</b>	68.
	34"	<b>R2HK0034</b>	92.
	42"	<b>R2HK0042</b>	98.
	49"	<b>R2HK0049</b>	106.
	64"	<b>R2HK0064</b>	115.
	79"	<b>R2HK0079</b>	120.
Beltway hookstrips	42"	<b>R2HKB042</b>	106.
	49"	<b>R2HKB049</b>	115.
	64"	<b>R2HKB064</b>	120.
	79"	<b>R2HKB079</b>	126.
Generation 2 top caps		<b>KRR2CAPL()</b>	60.
		<b>KRR2CAPT()</b>	60.
		<b>KRR2CAPX()</b>	60.
		<b>KRR2CAPEND()</b>	60.
		<b>KRR2CAPSTRAIGHT()</b>	60.
Generation 3 top caps		<b>KRR3CAPL()</b>	60.
		<b>KRR3CAPT()</b>	60.
		<b>KRR3CAPX()</b>	60.
		<b>KRR3CAPSTRAIGHT()</b>	60.
		<b>KRR3CAPEND()</b>	60.





Accessories and Client Samples

Order Code	Specification Information	Application Notes
Example: <b>KRR3CAPL-2A</b>	<i>To order please specify pattern number including:</i>	Applicable finishes are listed on page 5 and 6.
<b>KRR3</b> Reff generation 3	1. L = Laminate paint finish	
<b>CAP</b> Top cap	2. 1 = V1 Techwood	An additional 34", 42", 49", or 64" high hookstrip will be required for applications of high low high panel-to-panel connections not involving a post.
<b>L</b> Finished 2 adjacent sides	3. 2 = V2 Conventional veneer	
<b>2</b> Conventional veneer	<i>Top cap profile:</i>	
<b>A</b> Flat profile	A = Flat	Panel hookstrips and Beltway hookstrips are presented here to help prevent shortages for installations.
<b>V319</b> Medium cherry	B = Square	
	C = Bullnose	
		New top caps may be required for furniture reconfigurations. G2 and G3 top caps are required when the R3R2 SLV is specified.

# Accessories

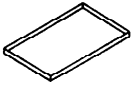
## *cabinet extras and undermount accessories*

Reff Profiles

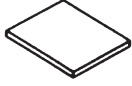
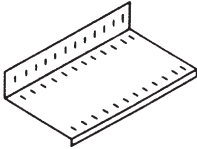
description	w	d	h	pattern no.	Metal	L	V1	V2	V3	list price
Cabinet boot tray 	14"	17"		<b>RCABT1417</b>						\$71.
	29"	17"		<b>RCABT2917</b>						118.
Cabinet coat rod 	Half of 30" cabinets			<b>RCACR30H</b>						69.
	Half of 36" cabinets			<b>RCACR36H</b>						75.
	16" cabinets			<b>RCACR16</b>						71.
	30" cabinets			<b>RCACR30</b>						94.
	36" cabinets			<b>RCACR36</b>						106.
Articulated keyboard arm 	10" x 22 1/4" keyboard tray			<b>RKBA1022( )</b>						840.
	10" x 20" keyboard tray			<b>RKBA1020( )</b>						840.
Available in laminate, techwood (V1), or veneer (V2)										
CRT turntable 	31" diameter			<b>RKT31</b>						518.
Pencil drawer used under worktop 	16"	17"	1"	<b>RPAD-( )</b>		287.	511.	511.	662.	
	Specify wood or laminate finish									
Cabinet shelves, (replacement)  Wood shelf  Metal shelf	16"	20"		<b>RCAS1620-( )</b>	72.	135.	144.	166.	223.	
	16"	24"		<b>RCAS1624-( )</b>	80.	151.	163.	189.	254.	
	30"	15"		<b>RCAS3015-( )</b>	88.	177.	190.	217.	293.	
	30"	20"		<b>RCAS3020-( )</b>	85.	151.	163.	189.	254.	
	30"	24"		<b>RCAS3024-( )</b>	95.	177.	190.	217.	293.	
	36"	15"		<b>RCAS3615-( )</b>	97.	188.	199.	225.	304.	
	36"	20"		<b>RCAS3620-( )</b>	97.	162.	173.	199.	269.	
	36"	24"		<b>RCAS3624-( )</b>	102.	190.	203.	232.	314.	

### Order Code

To order please specify pattern number including:

1. Finish type, where applicable
2. Finish, where applicable

1. Finish type:

L = laminate

1 = V1

2 = V2

M = Metal

### Specification Information

Pencil drawer includes slides.



Applicable finishes are listed on page 5 and 6.

### Application Notes

See Reff Planning Guide for more information.

# Accessories

## *presentation samples*

description	w	d	h	pattern no.	L	M/V1	V2	V3	list price
Wall rails (paint options only) 	-	-	8 <sup>7</sup> / <sub>8</sub> "	<b>RWHRA-()</b>					\$36.
	-	-	17 <sup>5</sup> / <sub>8</sub> "	<b>RWHRB-()</b>					39.
	-	-	18 <sup>1</sup> / <sub>4</sub> "	<b>RWHRC-()</b>					39.
	-	-	21 <sup>1</sup> / <sub>16</sub> "	<b>RWHRD-()</b>					41.
	-	-	22"	<b>RWHRE-()</b>					41.
	-	-	59 <sup>1</sup> / <sub>2</sub> "	<b>RWHRF-()</b>					92.
	-	-	67"	<b>RWHRG-()</b>					92.
Striplight (black only) for transaction tops 	26"	2"	2"	<b>RCASL</b>					328.
Presentation wood sample, 16" x 16" Optional edge details available	16"	16"	-	<b>RSAMP1616-()()</b>	130.	182.	234.	271.	
Presentation stackable/tiled mini panel (for demonstrations) Specify trim profile, base height, base type and applicable finishes	24"	-	34"	<b>R3SMP ()()</b>					1,047.
Presentation monolithic mini panel Specify trim profile and applicable finishes	4"H base			<b>RR3MP4 ()</b>					573.
	6"H base			<b>RR3MP6 ()</b>					613.
Presentation metal D-pull sample board Includes 6 different color handles Optional veneer for board				<b>R917762 ()</b>					419.
Presentation worksurface cutaway sample	12"	12"	1 <sup>1</sup> / <sub>4</sub> "	<b>RTOP2 ()</b>	107.	160.	214.	251.	
	12"	12"	1 <sup>3</sup> / <sub>4</sub> "	<b>RTOP1 ()</b>	107.	160.	214.	251.	
Presentation waterfall edge sample	11"	8 <sup>1</sup> / <sub>2</sub> "		<b>R921655 ()</b>					318.
Sample, cascade edge worksurface 	12"	12"		<b>RCE1R1212G</b>	123.				
Rangeboard Recommended for natural veneer with clear coat (V311, V316) and Light finishes (such as V312, V315)	27"	12"	1 <sup>1</sup> / <sub>4</sub> "	<b>RRBRD2712 ()</b>					287.

Accessories and Client Samples

### Order Code

### Specification Information

To order please specify pattern number including:

1. Finish type, where applicable
2. Finish, where applicable

1. Finish type:

L = Laminate

1 = V1

2 = V2

See Reff Planning Guide for more information.

Metal D-pull sample board represents the following standard Reff finishes (PT, 111, 118, 611, 612, 613)

Specify board finish in laminate, techwood, conventional or laminate with a wood edge.

Specify edge detail if applicable for presentation wood samples.

Applicable finishes are listed on page 5 and 6.







Product on this page will accept woodgrain laminate where laminate is currently an option.

List price for woodgrain laminate options will be current published laminate list price plus 10%.

# Accessories

## wire management

Reff Profiles

description	w	d	h	pattern no.	list price
 Wire manager used under any top in kneespace*	24"	4 1/2"	5 3/4"	<b>RWMWT24</b>	\$41.
	30"	4 1/2"	5 3/4"	<b>RWMWT30</b>	47.
	36"	4 1/2"	5 3/4"	<b>RWMWT36</b>	51.
	Available black only				
 Hinged vertical wire	24"	1"	3/8"	<b>RWMV24 ( )</b>	33.
	Ships with overdesk unit. Specify paint finish.				
 Multi-purpose manager*	24"	2 1/2"	1 1/4"	<b>RWMMP24</b>	36.
	30"	2 1/2"	1 1/4"	<b>RWMMP30</b>	41.
	36"	2 1/2"	1 1/4"	<b>RWMMP36</b>	42.
	Available black only				
 Panel-hung vertical wire	24"	–	–	<b>RWMVP24</b>	33.
	not available in finish codes: 112,116,117,611, 612, 613				
 Worksurface vertical/horizontal wire manager*	24"	1 1/2"	3/4"	<b>RWMVH24</b>	39.
	30"	1 1/2"	3/4"	<b>RWMVH30</b>	43.
	36"	1 1/2"	3/4"	<b>RWMVH36</b>	47.
	Available black only				
 Power bar, fits into wire manager				<b>RWMPB</b>	142.
Replacement hardware	Top to endpanel disk			<b>RBDD</b>	5.
	Top to workwall endpanel disk			<b>RBDW</b>	5.
	Panel to endpanel bracket			<b>RBPE(L/R)( )</b>	19.
	Specify paint finish for RBPE(L/R) RBDD and RBDW available black only				

Order Code	Specification Information	Application Notes	Application Notes
Example: <b>RJBW24</b>	<i>To order please specify:</i> 1. Pattern number 2. Color if applicable	Specify color for hinged vertical wire management only from paint finish list on page 5.  * Available in Black only.	*Installation instruction sheets available on line.
<b>R</b> Reff			
<b>JB</b> J-Bracket			
<b>W</b> Wall and Modesty mount			
<b>24</b>			

# Accessories

## wire management

Reff Profiles

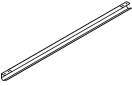
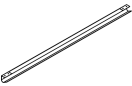
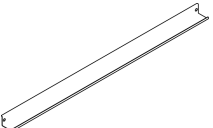
description	w	d	h	pattern no.	list price
Tree wire manager 2 shipped with panel	2"			<b>RBWM</b>	\$11.
used in Beltway					
J-Wire Trough Wall Mount				<b>RJBW24</b>	61.
				<b>RJBW30</b>	63.
				<b>RJBW36</b>	69.
				<b>RJBW42</b>	81.
				<b>RJBW48</b>	85.
				<b>RJBW54</b>	87.
				<b>RJBW60</b>	88.
				<b>RJBW66</b>	100.
				<b>RJBW72</b>	101.
*Installation Instruction Sheet: 6TP00078					
J-Wire Trough Under Mount				<b>RJBU24</b>	74.
				<b>RJBU30</b>	76.
				<b>RJBU36</b>	83.
				<b>RJBU42</b>	95.
				<b>RJBU48</b>	102.
				<b>RJBU54</b>	104.
				<b>RJBU60</b>	106.
				<b>RJBU66</b>	117.
				<b>RJBU72</b>	119.
*Installation Instruction Sheet: 6TP00079					
Wire manager for credenza top				<b>RWMCT24</b>	121.
					

Accessories and Client Samples

Order Code	Specification Information	Application Notes	Application Notes
Example: <b>RJBW24</b>	<i>To order please specify:</i> 1. Pattern number 2. Color if applicable	Specify color for hinged vertical wire management only from paint finish list on page 5.  *Available in Black only.	*Installation instruction sheets available on line.
<b>R</b> Reff			
<b>JB</b> J-Bracket			
<b>W</b> Wall and Modesty mount			
<b>24</b>			

# Accessories

## *Power and Data*

Reff Profiles

description	type	w	d	h	pattern no.	list
Desktop Outlet - Power Center stand off					<b>RDTE22120</b>	\$335.
					<b>RDTE2272</b>	312.
					<b>RDTE22H</b>	343.
Simple Stand Off					<b>RST</b>	102.
Stand Off for Power Center (Electrical component not included)					<b>RPCST()</b>	130.
Power Center Grommet (Electrical component not included)					<b>RPCG</b>	149.
Desktop Grommet	For 1 1/2" thick top			1 1/2"	<b>RDGA</b>	32.
	For 1 1/4" thick top			1 1/4"	<b>RDGB</b>	32.
	For 1" thick top			1"	<b>RDGC</b>	32.

Order Code	Specification Information	Application Notes
Example: <b>RDTE2272</b>		
<b>R</b>	Reff	H = Hard wire
<b>DT</b>	Desktop Outlet	Installation instruction sheet available on line.
<b>E</b>	Electrical component	
<b>2</b>	2 Electrical	For Power Center stand off, refer to part number 6TP00081.
<b>2</b>	2 Data	
<b>72</b>	72" cord	



# Accessories

## *interior components*

description	type	w	h	pattern no.	list price
Panel-hung coat hook (hookstrip)				<b>RPHCHH</b>	\$33.
Not intended to work with (AA) Aluminum top trim					
Panel-hung coat hook (panel top)				<b>RPHCHT</b>	33.
Panel-hung tackboard		30"	24"	<b>RPHTB3024</b>	278.
Note: Fabric railroaded		42"	24"	<b>RPHTB4224</b>	342.
All standard grades of fabric					
Panel-hung whiteboard		30"	24"	<b>RPHWB3024</b>	431.
		42"	24"	<b>RPHWB4224</b>	527.
Wall-hung tackboard		30"	24"	<b>RWHTB3024</b>	308.
Note: Fabric railroaded Velcro supplied		36"	24"	<b>RWHTB3624</b>	342.
		42"	24"	<b>RWHTB4224</b>	375.
		48"	24"	<b>RWHTB4824</b>	408.
for use with 26 1/2" h support planning module					
Wall-hung tackboard for desk height (28 3/8" h) planning		30"	26"	<b>RWHDHTB3026</b>	324.
Note: Fabric railroaded Velcro supplied		36"	26"	<b>RWHDHTB3626</b>	358.
		42"	26"	<b>RWHDHTB4226</b>	395.
		48"	26"	<b>RWHDHTB4826</b>	428.
for use with 28 3/8" h support planning module					
Box drawer dividers, wood box drawers (Acrylic)		16"	–	<b>RPADSS</b>	49.
File bars, wood file drawers (replacement)		16"	–	<b>RPAHFB16</b>	27.
		30"	–	<b>RPAHFB30</b>	52.
		36"	–	<b>RPAHFB36</b>	81.
File bars, metal file drawers (replacement)		16"	–	<b>RPAHFM162 *</b>	19.
		30"	–	<b>RPAHFM30</b>	27.
		36"	–	<b>RPAHFM36</b>	27.
Sold as individuals					

### Order Code

To order please specify:  
 1. Pattern number  
 2. Fabric (Tackboards)

### Application Notes

See Reff Planning Guide for more information.  
 Panel hung coat hook for hookstrip can be adjusted vertically in 1" nominal increments. Panel hung coat hook that sits underneath the panel top trim cannot be height-adjusted.

Replacement pencil trays for pedestals shipped July 2001 and prior should order KR5914265. Replacement pencil trays for all mobile pedestals, should order KR5914265.  
 Replacement file bars for all mobile pedestals and pedestals shipped July 2001 and prior, should order KR5231078.

# Accessories

## *interior components*

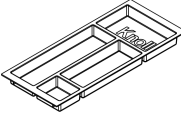
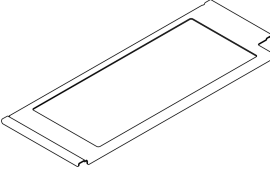
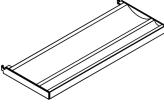
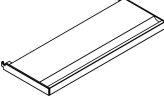
description	type	w	h	pattern no.	list price
Plate divider 				<b>RPD11</b>	\$21.
				<b>RPD14</b>	21.
RPD11 to be used with 15" D open cabinet/bookcase with metal shelves. RPD14 to be used with 20"/24"D open cabinet/bookcase with metal shelves.					
Pencil tray, wood (ordered separately)		12"	–	<b>RPAPT</b>	94.
Pencil tray, plastic 	black	12"	–	<b>RPETRAY3N</b>	36.
	clear	12"	–	<b>RPETRAY3C</b>	43.
Recommended for use with metal drawer interiors on 16"w peds. Letter width pedestal.					
Pencil tray adapter 				<b>RPETAD</b>	78.
Includes metal adapter pencil tray and plastic pencil tray to be used with 19" wide (Legal width) pedestals. Available in painted and anodized finishes.					
Task Panel shelf 		14"		<b>RTST14</b>	158.
Task Panel flat tray 		14"		<b>RTSF14</b>	158.
		28"		<b>RTSF28</b>	188.

### Order Code

To order please specify:  
1. Pattern number  
2. Fabric (Tackboards)

### Application Notes



See Reff Planning Guide for more information.

Panel hung coat hook for hookstrip can be adjusted vertically in 1" nominal increments. Panel hung coat hook that sits underneath the panel top trim cannot be height-adjusted.

Replacement pencil trays for pedestals shipped July 2001 and prior should order KR5914265. Replacement pencil trays for all mobile pedestals, should order KR5914265.

Replacement file bars for all mobile pedestals and pedestals shipped July 2001 and prior, should order KR5231078.

Accessories  
Fascias  
Metal

description	w	pattern no.	P1/P2	P3
Metal Fascia - Both left and right recess 	30"	<b>ROMDHMTF130RB</b>	\$137.	\$164.
	36"	<b>ROMDHMTF136RB</b>	140.	168.
	42"	<b>ROMDHMTF142RB</b>	141.	169.
	48"	<b>ROMDHMTF148RB</b>	143.	172.
	54"	<b>ROMDHMTF154RB</b>	146.	175.
	60"	<b>ROMDHMTF160RB</b>	148.	178.
	66"	<b>ROMDHMTF166RB</b>	156.	187.
	72"	<b>ROMDHMTF172RB</b>	158.	190.
	78"	<b>ROMDHMTF178RB</b>	160.	192.
	84"	<b>ROMDHMTF184RB</b>	162.	194.
	90"	<b>ROMDHMTF190RB</b>	164.	197.
96"	<b>ROMDHMTF196RB</b>	166.	199.	
Metal Fascia - Left recess 	30"	<b>ROMDHMTF130RL</b>	137.	164.
	36"	<b>ROMDHMTF136RL</b>	140.	168.
	42"	<b>ROMDHMTF142RL</b>	141.	169.
	48"	<b>ROMDHMTF148RL</b>	143.	172.
	54"	<b>ROMDHMTF154RL</b>	146.	175.
	60"	<b>ROMDHMTF160RL</b>	148.	178.
	66"	<b>ROMDHMTF166RL</b>	156.	187.
	72"	<b>ROMDHMTF172RL</b>	158.	190.
	78"	<b>ROMDHMTF178RL</b>	160.	192.
	84"	<b>ROMDHMTF184RL</b>	162.	194.
	90"	<b>ROMDHMTF190RL</b>	164.	197.
96"	<b>ROMDHMTF196RL</b>	166.	199.	
Metal Fascia - No recess 	30"	<b>ROMDHMTF130RN</b>	137.	164.
	36"	<b>ROMDHMTF136RN</b>	140.	168.
	42"	<b>ROMDHMTF142RN</b>	141.	169.
	48"	<b>ROMDHMTF148RN</b>	143.	172.
	54"	<b>ROMDHMTF154RN</b>	146.	175.
	60"	<b>ROMDHMTF160RN</b>	148.	178.
	66"	<b>ROMDHMTF166RN</b>	156.	187.
	72"	<b>ROMDHMTF172RN</b>	158.	190.
	78"	<b>ROMDHMTF178RN</b>	160.	192.
	84"	<b>ROMDHMTF184RN</b>	162.	194.
	90"	<b>ROMDHMTF190RN</b>	164.	197.
96"	<b>ROMDHMTF196RN</b>	166.	199.	

Accessories and Client Samples

Order Code	Specification Information	Application Notes
Example: <b>ROMDHMTF130RB</b> <b>R</b> Recess <b>O</b> Overhead <b>M</b> Wall hung <b>DH</b> Desk height <b>M</b> Metal <b>T</b> Task light <b>F</b> Fascia <b>1</b> Letter depth <b>30</b> 30" <b>R</b> Recess <b>B</b> Recess location <b>118</b> Finish	To order please specify pattern number including: 1. Finish Anodized and Core paint finishes.	For single and double high overheads. Wood and metal options. Letter depth only. For Anodized Finishes, Please add \$55 to P3 List Price.

Accessories  
*Fascias*  
*Metal*

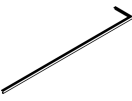
description	w	pattern no.	P1/P2	P3
Metal Fascia - Right recess 	30"	<b>ROMDHMTF130RR</b>	\$137.	\$164.
	36"	<b>ROMDHMTF136RR</b>	140.	168.
	42"	<b>ROMDHMTF142RR</b>	141.	169.
	48"	<b>ROMDHMTF148RR</b>	143.	172.
	54"	<b>ROMDHMTF154RR</b>	146.	175.
	60"	<b>ROMDHMTF160RR</b>	148.	178.
	66"	<b>ROMDHMTF166RR</b>	156.	187.
	72"	<b>ROMDHMTF172RR</b>	158.	190.
	78"	<b>ROMDHMTF178RR</b>	160.	192.
	84"	<b>ROMDHMTF184RR</b>	162.	194.
	90"	<b>ROMDHMTF190RR</b>	164.	197.
	96"	<b>ROMDHMTF196RR</b>	166.	199.

Order Code	Specification Information	Application Notes
Example: <b>ROMDHMTF130RB</b>	<i>To order please specify pattern number including:</i> 1. Finish Anodized and Core paint finishes.	For single and double high overheads. Wood and metal options. Letter depth only. For Anodized Finishes, Please add \$55 to P3 List Price.
<b>R</b> Recess		
<b>O</b> Overhead		
<b>M</b> Wall hung		
<b>DH</b> Desk height		
<b>M</b> Metal		
<b>T</b> Task light		
<b>F</b> Fascia		
<b>1</b> Letter depth		
<b>30</b> 30"		
<b>R</b> Recess		
<b>B</b> Recess location		
<b>118</b> Finish		

Accessories  
Fascias  
Wood

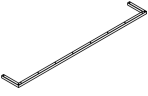
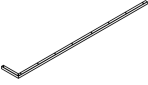
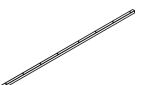
description	w	pattern no.	V1	V2	V3
Wood Fascia - Both left and right recess 	30"	<b>ROMDHWTF130RB</b>	\$252.	\$273.	\$341.
	36"	<b>ROMDHWTF136RB</b>	254.	276.	345.
	42"	<b>ROMDHWTF142RB</b>	256.	279.	349.
	48"	<b>ROMDHWTF148RB</b>	258.	282.	353.
	54"	<b>ROMDHWTF154RB</b>	260.	285.	357.
	60"	<b>ROMDHWTF160RB</b>	375.	396.	495.
	66"	<b>ROMDHWTF166RB</b>	377.	399.	499.
	72"	<b>ROMDHWTF172RB</b>	379.	402.	503.
	78"	<b>ROMDHWTF178RB</b>	381.	405.	507.
	84"	<b>ROMDHWTF184RB</b>	383.	408.	511.
	90"	<b>ROMDHWTF190RB</b>	385.	411.	515.
96"	<b>ROMDHWTF196RB</b>	526.	548.	685.	
Wood Fascia - Left recess 	30"	<b>ROMDHWTF130RL</b>	252.	273.	341.
	36"	<b>ROMDHWTF136RL</b>	254.	276.	345.
	42"	<b>ROMDHWTF142RL</b>	256.	279.	349.
	48"	<b>ROMDHWTF148RL</b>	258.	282.	353.
	54"	<b>ROMDHWTF154RL</b>	260.	285.	357.
	60"	<b>ROMDHWTF160RL</b>	375.	396.	495.
	66"	<b>ROMDHWTF166RL</b>	377.	399.	499.
	72"	<b>ROMDHWTF172RL</b>	379.	402.	503.
	78"	<b>ROMDHWTF178RL</b>	381.	405.	507.
	84"	<b>ROMDHWTF184RL</b>	383.	408.	511.
	90"	<b>ROMDHWTF190RL</b>	385.	411.	515.
96"	<b>ROMDHWTF196RL</b>	526.	548.	685.	
Wood Fascia - No recess 	30"	<b>ROMDHWTF130RN</b>	252.	273.	341.
	36"	<b>ROMDHWTF136RN</b>	254.	276.	345.
	42"	<b>ROMDHWTF142RN</b>	256.	279.	349.
	48"	<b>ROMDHWTF148RN</b>	258.	282.	353.
	54"	<b>ROMDHWTF154RN</b>	260.	285.	357.
	60"	<b>ROMDHWTF160RN</b>	375.	396.	495.
	66"	<b>ROMDHWTF166RN</b>	377.	399.	499.
	72"	<b>ROMDHWTF172RN</b>	379.	402.	503.
	78"	<b>ROMDHWTF178RN</b>	381.	405.	507.
	84"	<b>ROMDHWTF184RN</b>	383.	408.	511.
	90"	<b>ROMDHWTF190RN</b>	385.	411.	515.
96"	<b>ROMDHWTF196RN</b>	526.	548.	685.	

Accessories and Client Samples

Order Code	Specification Information	Application Notes
Example: <b>ROMDHWTF130RB</b>	<i>To order please specify pattern number including:</i> 1. Finish L, V1, V2, V3	For single and double high overheads.  Wood and metal options.  Letter depth only.
<b>R</b> Recess		
<b>O</b> Overhead		
<b>M</b> Wall hung		
<b>DH</b> Desk height		
<b>W</b> Wood		
<b>T</b> Task light		
<b>F</b> Fascia		
<b>1</b> Letter depth		
<b>30</b> 30"		
<b>R</b> Recess		
<b>B</b> Recess location		
<b>V316</b> Finish		

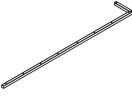

Accessories  
*Fascias*  
*Wood*

description	w	pattern no.	V1	V2	V3
Wood Fascia - Right recess 	30"	<b>ROMDHWTF130RR</b>	\$252.	\$273.	\$341.
	36"	<b>ROMDHWTF136RR</b>	254.	276.	345.
	42"	<b>ROMDHWTF142RR</b>	256.	279.	349.
	48"	<b>ROMDHWTF148RR</b>	258.	282.	353.
	54"	<b>ROMDHWTF154RR</b>	260.	285.	357.
	60"	<b>ROMDHWTF160RR</b>	375.	396.	495.
	66"	<b>ROMDHWTF166RR</b>	377.	399.	499.
	72"	<b>ROMDHWTF172RR</b>	379.	402.	503.
	78"	<b>ROMDHWTF178RR</b>	381.	405.	507.
	84"	<b>ROMDHWTF184RR</b>	383.	408.	511.
	90"	<b>ROMDHWTF190RR</b>	385.	411.	515.
	96"	<b>ROMDHWTF196RR</b>	526.	548.	685.

Order Code	Specification Information	Application Notes
Example: <b>ROMDHWTF130RB</b>	<i>To order please specify pattern number including:</i> 1. Finish L, V1, V2, V3	For single and double high overheads.  Wood and metal options.  Letter depth only.
<b>R</b> Reff		
<b>O</b> Overhead		
<b>M</b> Wall hung		
<b>DH</b> Desk height		
<b>W</b> Wood		
<b>T</b> Task light		
<b>F</b> Fascia		
<b>1</b> Letter depth		
<b>30</b> 30"		
<b>R</b> Recess		
<b>B</b> Recess location		
<b>V316</b> Finish		

# Accessories

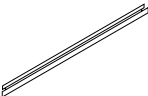
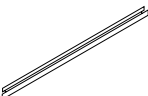
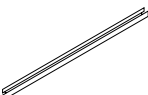
## Sliding Rails

description	width	pattern no.	list price
Sliding rail for open shelves 	30"	<b>RSDR30</b>	\$51.
	36"	<b>RSDR36</b>	51.
	42"	<b>RSDR42</b>	51.
	48"	<b>RSDR48</b>	51.
	54"	<b>RSDR54</b>	51.
	60"	<b>RSDR60</b>	81.
	66"	<b>RSDR66</b>	81.
	72"	<b>RSDR72</b>	81.
	78"	<b>RSDR78</b>	81.
	84"	<b>RSDR84</b>	90.
Sliding rail for open or hinged door overhead cabinets 	30"	<b>ROHDR30</b>	51.
	36"	<b>ROHDR36</b>	51.
	42"	<b>ROHDR42</b>	51.
	48"	<b>ROHDR48</b>	51.
	60"	<b>ROHDR60</b>	90.
	72"	<b>ROHDR72</b>	90.
	90"	<b>ROHDR90</b>	122.
Sliding rail for flip door overhead cabinets 	30"	<b>RFDR30</b>	51.
	36"	<b>RFDR36</b>	51.
	42"	<b>RFDR42</b>	51.
	48"	<b>RFDR48</b>	51.
	60"	<b>RFDR60</b>	90.
	72"	<b>RFDR72</b>	90.
	84"	<b>RFDR84</b>	90.
Sliding rail divider 		<b>R5ZNNE (3 dividers)</b>	21.

Order Code	
Example: <b>RSDR30</b>	
<b>R</b>	Reff
<b>SDR</b>	Sliding rail for open shelves
<b>30</b>	For 30" shelf



**Specification Information**  
*To order please specify pattern number.*

**Application Notes**  
 Match cabinet width to rail width.  
 Parts come in black only.  
 These rails allow the use of metal "D"-ring divider to locate and separate binders and standing materials in Reff overhead cabinets. The rail which attaches to the inside back section of the cabinet is sold according to cabinet size door configuration.

# Accessories

## Task Light

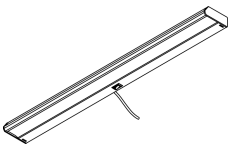
### Reff

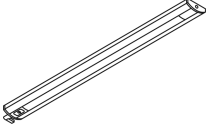
description	type	w	d	h	pattern no.	list
	Use with 24" and wider overhead	19"	4"	1 1/2"	<b>RTL5E19S</b>	\$262.
	Use with 30" and wider overhead	25"	4"	1 1/2"	<b>RTL5E25S</b>	268.
	Use with 42" and wider overhead	37"	4"	1 1/2"	<b>RTL5E37S</b>	273.
	Use with 60" and wider overhead	49"	4"	1 1/2"	<b>RTL5E49S</b>	278.
	Use with 72" and wider overhead	61"	4"	1 1/2"	<b>RTL5E61S</b>	294.
	Use with 84" and wider overhead	73"	4"	1 1/2"	<b>RTL5E73S</b>	320.
	Use with 96" and wider overhead	85"	4"	1 1/2"	<b>RTL5E85S</b>	400.
	Use with 30" and wider overhead	25"	4"	1 1/2"	<b>RTL5E25A</b>	384.
	Use with 42" and wider overhead	37"	4"	1 1/2"	<b>RTL5E37A</b>	405.
	Use with 60" and wider overhead	49"	4"	1 1/2"	<b>RTL5E49A</b>	421.
	Use with 72" and wider overhead	61"	4"	1 1/2"	<b>RTL5E61A</b>	438.
	Use with 84" and wider overhead	73"	4"	1 1/2"	<b>RTL5E73A</b>	453.
	Use with 96" and wider overhead	85"	4"	1 1/2"	<b>RTL5E85A</b>	470.
	Use with 24" and wider overhead (3 LED's)	19"	2"	3/16"	<b>RTL193W</b>	297.
	Use with 24" and wider overhead (6 LED's)	19"	2"	3/16"	<b>RTL196W</b>	375.
	Use with 24" and wider overhead (9 LED's)	19"	2"	3/16"	<b>RTL199W</b>	511.
	Use with 42" and wider overhead (6 LED's)	37"	2"	3/16"	<b>RTL376W</b>	599.
	Use with 42" and wider overhead (12 LED's)	37"	2"	3/16"	<b>RTL3712W</b>	677.
	Use with 42" and wider overhead (18 LED's)	37"	2"	3/16"	<b>RTL3718W</b>	839.

Order Code	Specification Information	Application Notes
<b>T5 Standard Task Light</b> Example: <b>RTL5E19S</b> <b>RTL</b> Task Light <b>T5</b> T5 lamp <b>E</b> Electronic ballast <b>19</b> Width <b>S</b> Standard <b>LED Task Light</b> Example: <b>RTL193W</b> <b>RTL</b> Task Light <b>L</b> LED <b>19</b> Width <b>3</b> # of LED's <b>W</b> Wood Overhead Attachment	<b>T5 Task Lights:</b> 120v and includes T5 cool white (4100K) fluorescent lamp, electronic ballast, 9' grounded cordset, prismatic lens, rocker switch, one cord exit management clip and mounting hardware. Housings are black.  <b>LED Task Lights:</b> Includes LED's, power supply with 12' cord and mounting hardware. Housings are clear anodized aluminum with grey color end-caps.	<b>T5 Task Lights:</b> Specify suffix -CH and add \$45 list for City of Chicago installations. Example: DL3T5E25S-CH  Cordset is center exit. On smaller units cord exit is off-center, but still not handed.  T5 advanced task lights are fitted with ballasts and lamps compliant with LEED requirements, meeting the LEED EB standard for mercury content.  <b>LED Task Lights:</b> Power cord is able to attach to either end of fixture.  <b>Notes:</b> All task lights mount into the recess in the underside of overhead cabinets and shelves at least 6" wider than task light width.  All task lights are TCLP compliant and meet requirements of California Title 20 and Title 24.



# Task Panels

## Planning Guidelines and Specifications

### Task Panels

The high performance Task Panel is designed to augment the utility of the zone immediately above the credenza in a Private Office setting, by offering tool rail capability and cable management features in addition to tackable and decorative inserts. All Task Panels have a cable curtain along the full length of the bottom edge which, when used in conjunction with notched back credenza tops, provides access to in-wall power sources and for cable concealment. See figure on following page for cable management details. The optional tool rail is designed to accept slatwall accessories and the Reff Profiles Task Panel Shelf. Slatwall accessories are available from KnollExtra. Insert panels may be conveniently removed, exposing a  $\frac{7}{8}$ " wire clearance space which allows cable drops at any point along the entire width of the Task Panel. Check local electrical codes for suitability.

Task Panels are configured in eight heights (H1 – H8) to correspond to their application. See application diagrams on the following pages. H1 and H2 are designed for focused work applications whereas H3 through H8 are designed for collaborative or team work applications.

### Construction

The Task Panel consists of a framework and optional tool rail, with decorative trims and a variety of functional and decorative inserts. See figures below for breakdown of components. Bottom right; The frame assembly consists of two vertical members, a bottom and top frame member and an optional tool rail. These are connected together and supported by mounting brackets. Edges have decorative trims; a top cover and two end covers.

Connected to the bottom frame member is a nylon brush which forms the cable curtain. Frames are clad with either one or two inserts depending upon the use of the tool rail. Bottom left (upper); single monolithic insert with spacers. Bottom left (lower); top segmented insert and bottom segmented insert and spacers.

Task Panels are shipped with frame and trim components, cable curtain and hardware in one container and inserts and spacers in a separate container.

The unit is field-assembled; fastened together using brackets and screws in pre-punched holes. See part #6TP00085 for assembly and installations instructions.

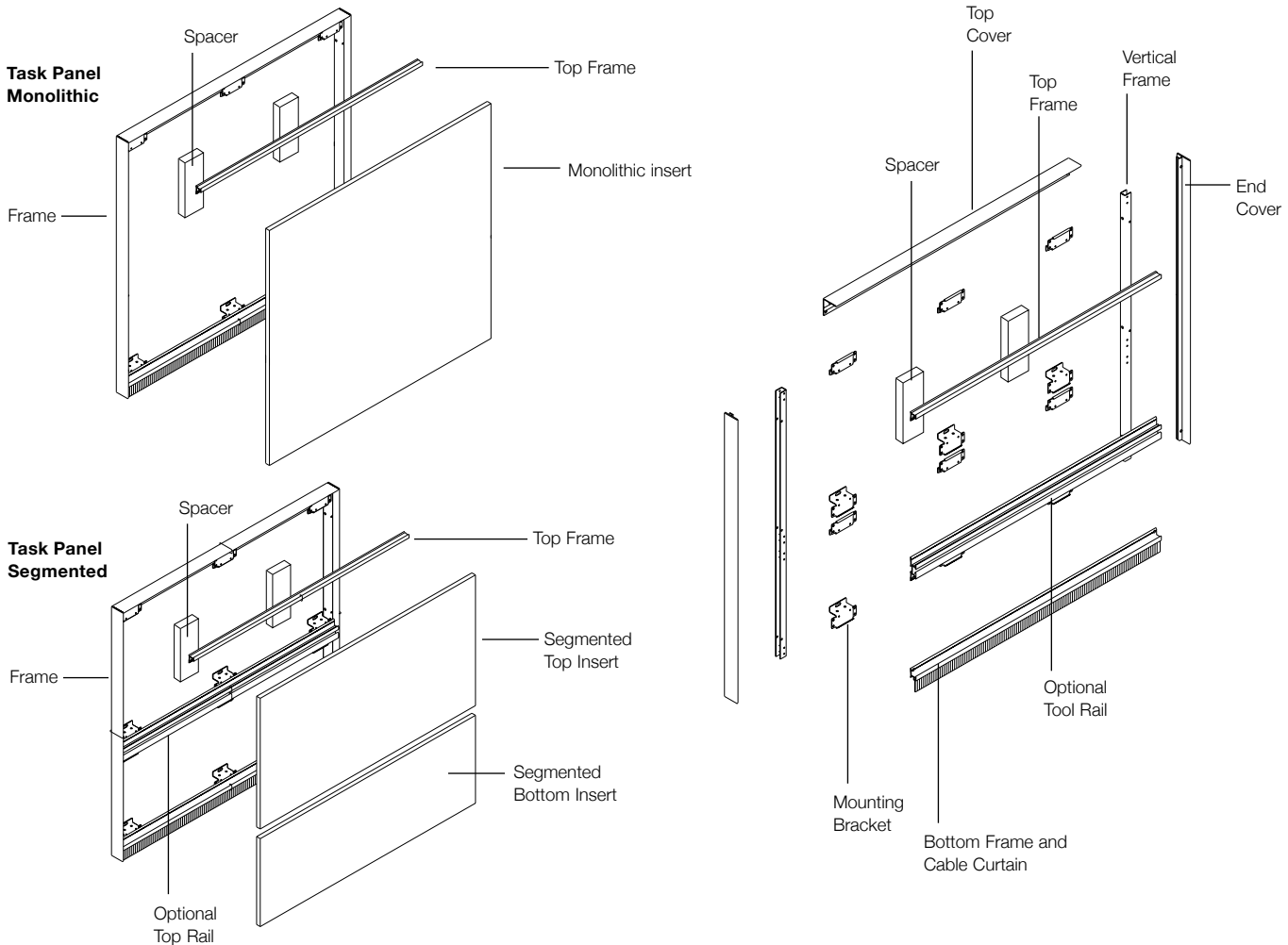

# Task Panels

## Planning Guidelines and Specifications

### Specification Options

Task Panels are offered in widths from 30" to 96" in 6" increments; and in eight application heights, H1 to H8. Overall thickness of the Task Panel is 1 1/2".

Task Panels are available in two basic configurations; monolithic (with a single insert) and segmented (with two inserts divided by the horizontal tool rail). See diagrams, previous page, for description.

The Task Panel cover trims and optional tool rail are offered in three anodized metallic finishes; Black (AN), Polished (AP) and Satin (AU) as well as all core paint colors. Refer to Reff Profiles finish options page for more information.

Task Panel inserts are available in a variety of finishes including fabric (tackable), Forbo™ (tackable linoleum), laminate, veneer, glass and marker board.

Note that segmented Task Panels with fabric lower inserts are available up to 72" wide.

### Planning Notes

1. H1, H3, H5 and H7 Task Panels are intended for use with 1 1/2" thick credenza tops. H2, H4, H6 and H8 Task Panels are intended for use with 1" credenza tops.
2. Fabric is applied to inserts railroad style only
3. Forbo™ is available on lower segmented inserts only
4. Grain direction for veneer inserts is vertical
5. Glass is not available for lower segmented inserts.

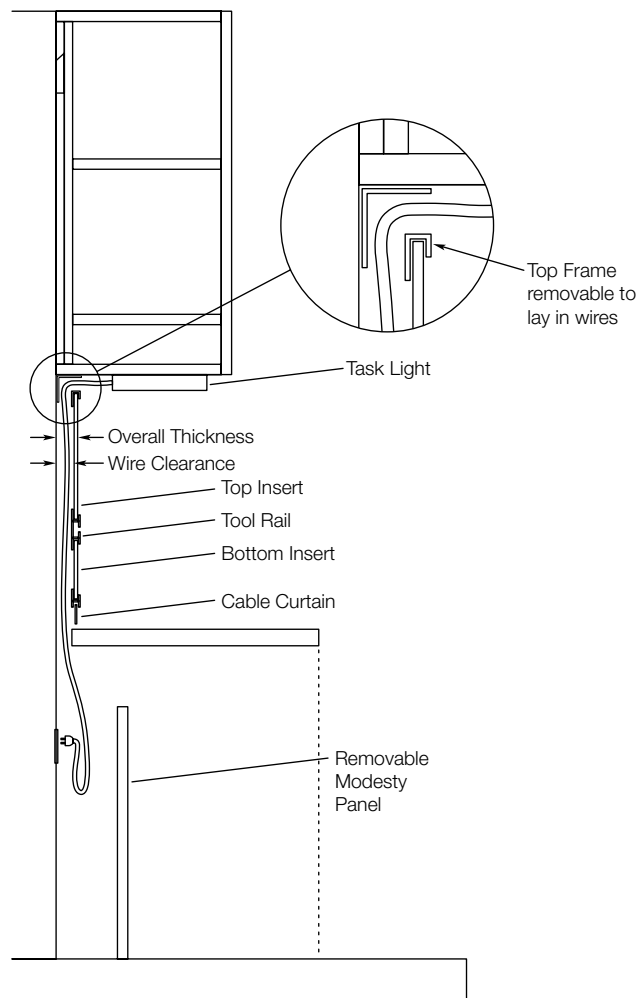

# Task Panels

## Planning Guidelines and Specifications

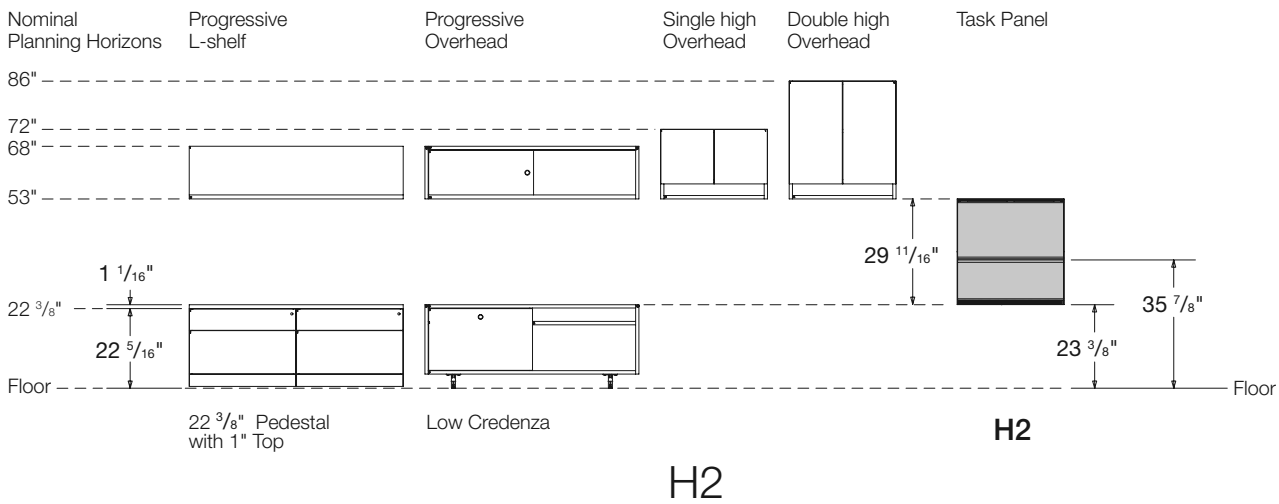
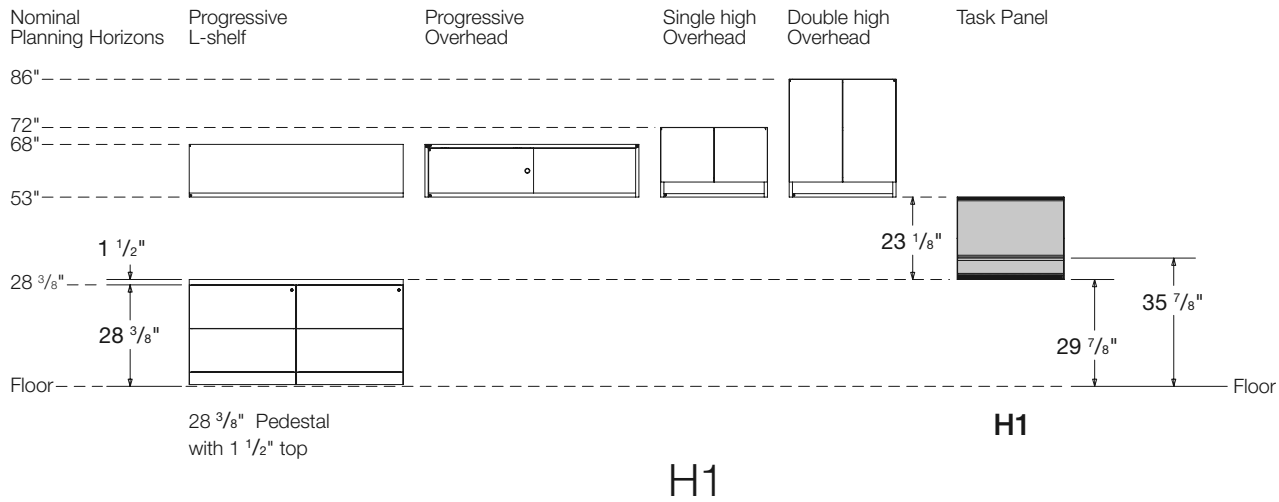

**Notes**

- Planning horizons are nominal. Dimensions are actual.
- Images displayed to the left of the Task Panel are examples only and do not represent the complete scope of products available.
- Task Panels available in monolithic and segmented; segmented shown
- H1 Task Panel is intended for use with 1 1/2" thick tops.
- H2 Task Panel is intended for use with 1" thick credenza tops.

# Task Panels

## Planning Guidelines and Specifications

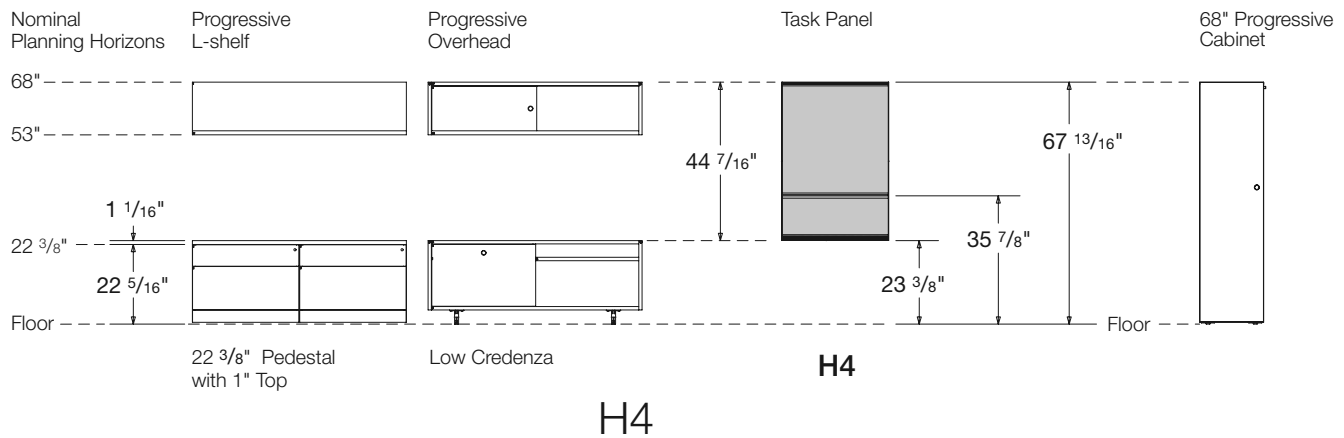
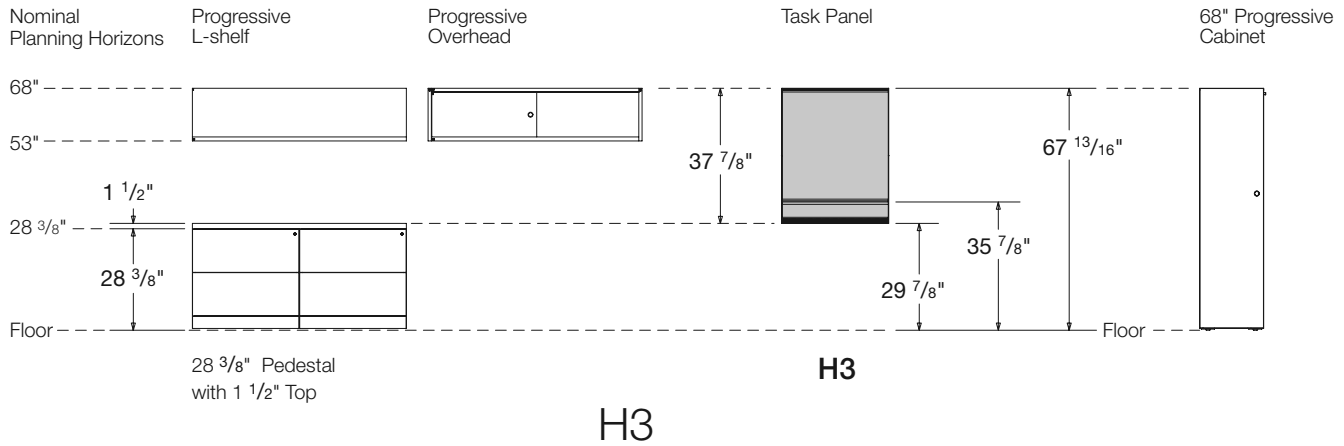

### Notes

- Planning horizons are nominal. Dimensions are actual.
- Images displayed to the left and right of the Task Panel are examples only and do not represent the complete scope of products available.
- Task Panels available in monolithic and segmented; segmented shown
- H3 Task Panel is intended for use with  $1\frac{1}{2}"$  thick tops.
- H4 Task Panel is intended for use with  $1"$  thick credenza tops.

# Task Panels

## Planning Guidelines and Specifications

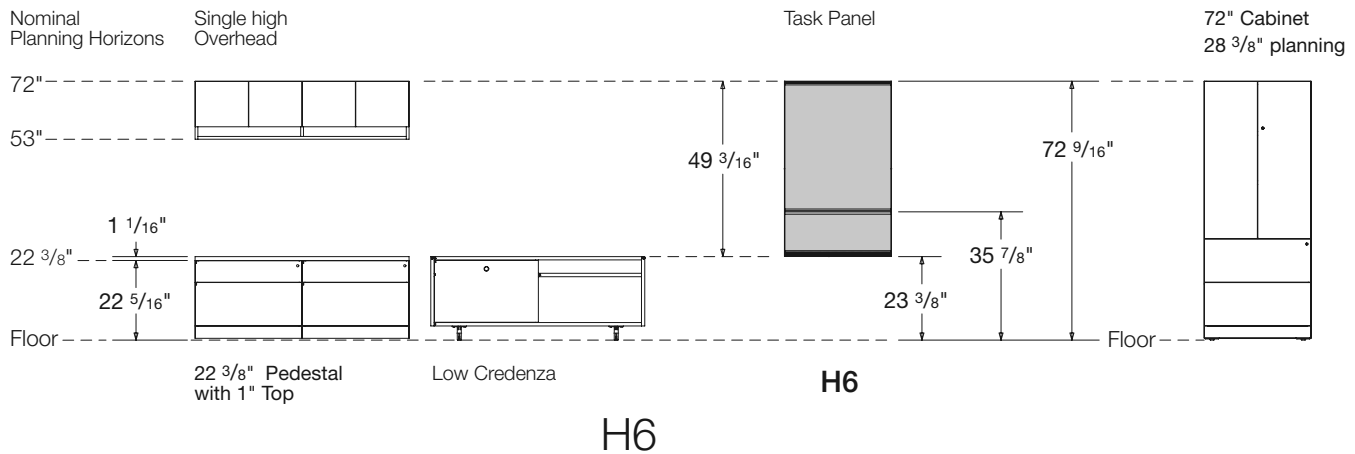
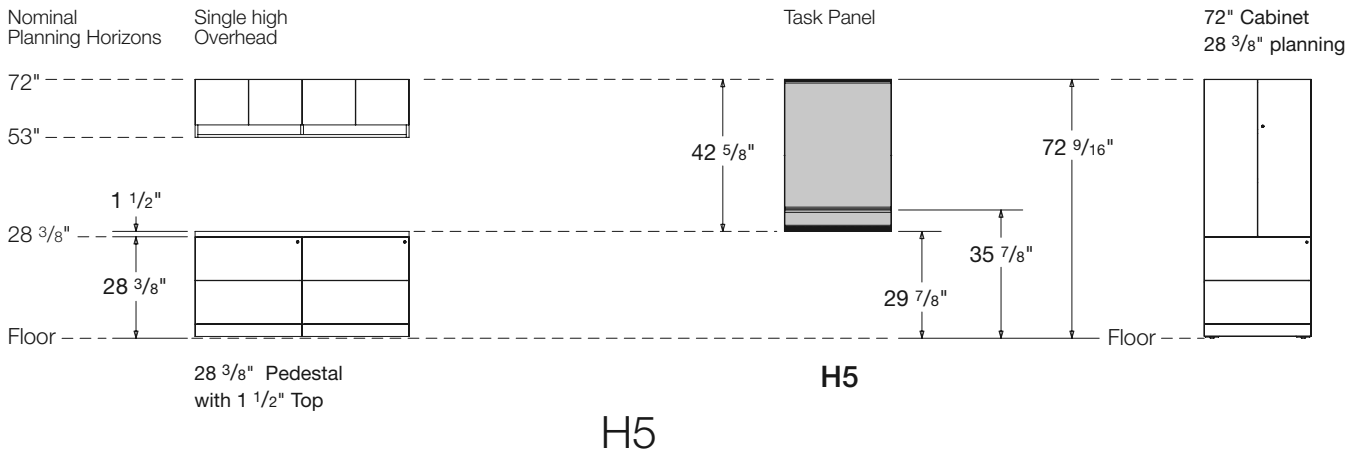

### Notes

- Planning horizons are nominal. Dimensions are actual.
- Images displayed to the left and right of the Task Panel are examples only and do not represent the complete scope of products available.
- Task Panels available in monolithic and segmented; segmented shown
- H5 Task Panel is intended for use with 1 1/2" thick tops.
- H6 Task Panel is intended for use with 1" thick credenza tops.

# Task Panels

## Planning Guidelines and Specifications

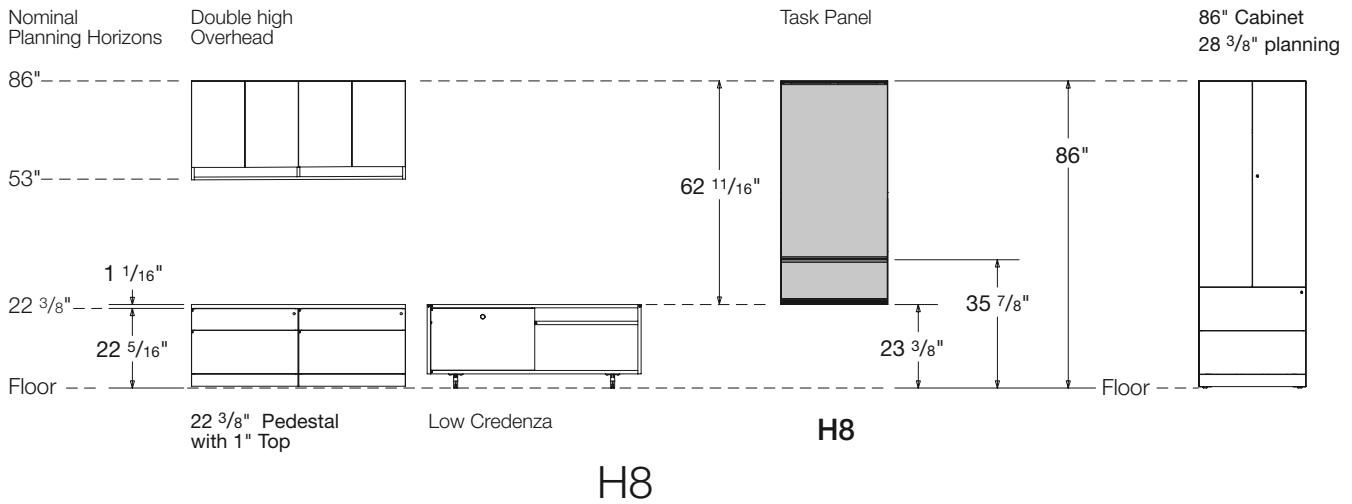
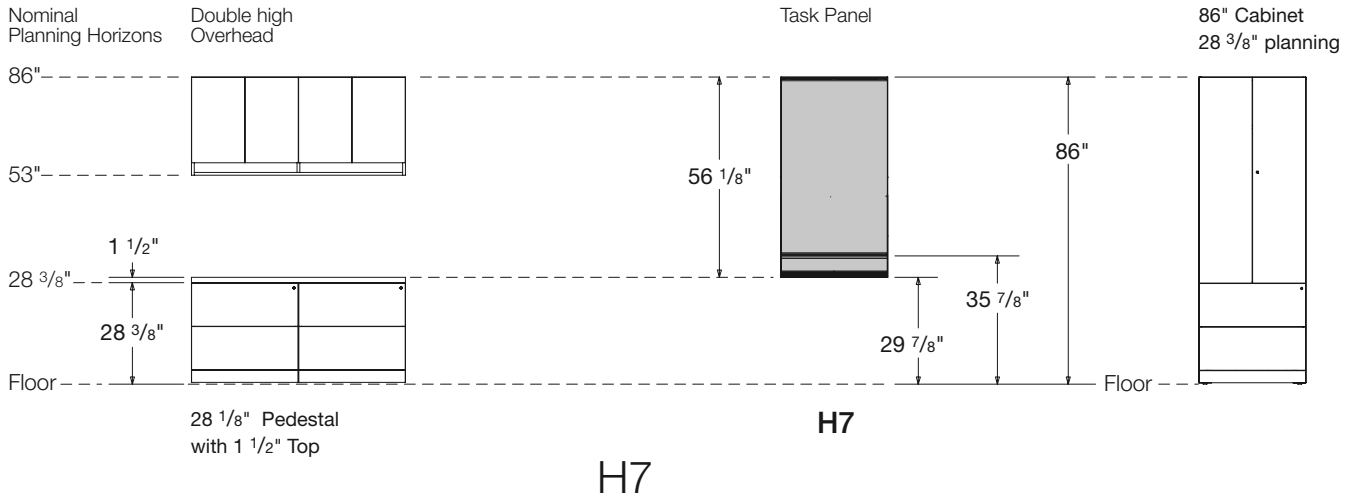

### Notes

- Planning horizons are nominal. Dimensions are actual.
- Images displayed to the left and right of the Task Panel are examples only and do not represent the complete scope of products available.
- Task Panels available in monolithic and segmented; segmented shown
- H7 Task Panel is intended for use with 1 1/2" thick tops.
- H8 Task Panel is intended for use with 1" thick credenza tops.

Task Panels  
*H1 23 1/8" high*  
*Monolithic, Without Tool rail*  
*Fabric*

description	th	h	w	pattern no.	grade						
					10	15	20	30	35	40	45
Task Panel, mono Without tool rail	1 1/2"	23 1/8"	30"	<b>RTPNM30H1( )()</b>	\$706.	\$720.	\$735.	\$749.	\$771.	\$785.	\$803.
	1 1/2"	23 1/8"	36"	<b>RTPNM36H1( )()</b>	758.	776.	794.	812.	836.	851.	870.
	1 1/2"	23 1/8"	42"	<b>RTPNM42H1( )()</b>	994.	1,015.	1,036.	1,057.	1,089.	1,108.	1,133.
	1 1/2"	23 1/8"	48"	<b>RTPNM48H1( )()</b>	1,006.	1,029.	1,052.	1,075.	1,107.	1,126.	1,152.
	1 1/2"	23 1/8"	54"	<b>RTPNM54H1( )()</b>	1,023.	1,049.	1,075.	1,101.	1,134.	1,154.	1,180.
	1 1/2"	23 1/8"	60"	<b>RTPNM60H1( )()</b>	1,084.	1,113.	1,142.	1,171.	1,206.	1,227.	1,255.
	1 1/2"	23 1/8"	66"	<b>RTPNM66H1( )()</b>	1,312.	1,343.	1,373.	1,404.	1,446.	1,471.	1,505.
	1 1/2"	23 1/8"	72"	<b>RTPNM72H1( )()</b>	1,331.	1,365.	1,399.	1,433.	1,476.	1,502.	1,536.
	1 1/2"	23 1/8"	78"	<b>RTPNM78H1( )()</b>	1,496.	1,533.	1,570.	1,607.	1,655.	1,684.	1,722.
	1 1/2"	23 1/8"	84"	<b>RTPNM84H1( )()</b>	1,505.	1,544.	1,583.	1,622.	1,671.	1,700.	1,739.
	1 1/2"	23 1/8"	90"	<b>RTPNM90H1( )()</b>	1,566.	1,608.	1,651.	1,693.	1,744.	1,774.	1,815.
	1 1/2"	23 1/8"	96"	<b>RTPNM96H1( )()</b>	1,584.	1,630.	1,675.	1,721.	1,773.	1,803.	1,845.

Order Code	Specification Information	Application Notes
Example: <b>RTPNM30H1( )()</b>	To order please specify pattern number including;	H1 Height: Underside of overhead to top 1 1/2" thick desk height worksurface.
<b>R</b> Reff	1. Trim Finish: Painted or Anodized	*Installation instruction sheets available on-line.
<b>TP</b> Task Panel	2. Insert Finish: Fabric	For Task Panels refer to part number 6TP00085
<b>N</b> No tool rail		
<b>M</b> Monolithic		
<b>30</b> Width		Always supplied including all trim pieces.
<b>H1</b> 23 1/8" high		LH & RH side full height trims. ( no hi-lo trims )
<b>111</b> Trim finish		All trims supplied with the same finish specification.
<b>W281</b> Fabric selection		Tool rails are not supplied to this Task Panel.
		All Fabric to be applied railroaded as current tackboard.
		When ordering 54" or wider Task Panel, please check width of fabric specified.

# Task Panels

Reff Profiles

*H1 23 1/8" high*

*Monolithic, Without Tool rail*

*Wood, Laminate, Marker board or Glass Inserts*

description	th	h	w	pattern no.	glass	LW	L	V1	V2	V3
Task Panel, mono	1 1/2"	23 1/8"	30"	<b>RTPNM30H1()</b>	\$944.	\$758.	\$751.	\$848.	\$908.	\$1,046.
Without tool rail	1 1/2"	23 1/8"	36"	<b>RTPNM36H1()</b>	1,056.	804.	795.	894.	962.	1,125.
	1 1/2"	23 1/8"	42"	<b>RTPNM42H1()</b>	1,288.	988.	977.	1,079.	1,151.	1,340.
	1 1/2"	23 1/8"	48"	<b>RTPNM48H1()</b>	1,380.	1,000.	988.	1,092.	1,172.	1,388.
	1 1/2"	23 1/8"	54"	<b>RTPNM54H1()</b>	1,456.	1,009.	996.	1,101.	1,190.	1,433.
	1 1/2"	23 1/8"	60"	<b>RTPNM60H1()</b>	1,576.	1,062.	1,048.	1,154.	1,253.	1,522.
	1 1/2"	23 1/8"	66"	<b>RTPNM66H1()</b>	1,871.	1,320.	1,304.	1,413.	1,525.	1,821.
	1 1/2"	23 1/8"	72"	<b>RTPNM72H1()</b>	1,949.	1,331.	1,314.	1,425.	1,550.	1,880.
	1 1/2"	23 1/8"	78"	<b>RTPNM78H1()</b>	2,174.	1,489.	1,470.	1,583.	1,711.	2,060.
	1 1/2"	23 1/8"	84"	<b>RTPNM84H1()</b>	2,251.	1,505.	1,484.	1,604.	1,736.	2,111.
	1 1/2"	23 1/8"	90"	<b>RTPNM90H1()</b>	2,371.	1,557.	1,535.	1,650.	1,798.	2,200.
	1 1/2"	23 1/8"	96"	<b>RTPNM96H1()</b>	2,449.	1,575.	1,552.	1,671.	1,821.	2,249.

Order Code	Specification Information	Application Notes
Example: <b>RTPNM30H1()</b>	To order please specify pattern number including;	H1 Height: Underside of overhead to top 1 1/2" thick desk height worksurface.
<b>R</b> Reff		*Installation instruction sheets available on-line.
<b>TP</b> Task Panel	1. Trim Finish: Painted or Anodized	For Task Panels refer to part number 6TP00085
<b>N</b> No tool rail	2. Insert Finish: Veneer	
<b>M</b> Monolithic		Always supplied including cable curtain.
<b>30</b> Width		Always supplied including all trim pieces.
<b>H1</b> 23 1/8" high		LH & RH side full height trims. ( no hi-lo trims )
<b>111</b> Trim finish		All trims supplied with the same finish specification.
<b>V319</b> Veneer selection		Tool rails are not supplied to this Task Panel.
		All Fabric to be applied railroaded as current tackboard
		When ordering 54" or wider Task Panel, please check width of fabric specified.



Task Panels  
*H1 23 1/8" high*  
*Segmented With Tool rail*  
*Fabric Insert Above / Fabric Insert Below*

description	th	h	w	pattern no.	grade						
					10	15	20	30	35	40	45
Task Panel, segmented	1 1/2"	23 1/8"	30"	RTPRS30H1()()	\$1,095.	\$1,124.	\$1,154.	\$1,183.	\$1,211.	\$1,240.	\$1,268.
With tool rail	1 1/2"	23 1/8"	36"	RTPRS36H1()()	1,179.	1,215.	1,250.	1,286.	1,317.	1,348.	1,378.
	1 1/2"	23 1/8"	42"	RTPRS42H1()()	1,423.	1,465.	1,507.	1,549.	1,586.	1,623.	1,660.
	1 1/2"	23 1/8"	48"	RTPRS48H1()()	1,443.	1,488.	1,534.	1,579.	1,617.	1,655.	1,692.
	1 1/2"	23 1/8"	54"	RTPRS54H1()()	1,473.	1,525.	1,577.	1,629.	1,668.	1,707.	1,746.
	1 1/2"	23 1/8"	60"	RTPRS60H1()()	1,503.	1,561.	1,620.	1,678.	1,718.	1,758.	1,799.
	1 1/2"	23 1/8"	66"	RTPRS66H1()()	1,839.	1,901.	1,962.	2,024.	2,072.	2,121.	2,169.
	1 1/2"	23 1/8"	72"	RTPRS72H1()()	1,871.	1,939.	2,008.	2,076.	2,126.	2,175.	2,225.

Order Code	Specification Information	Application Notes
Example: <b>RTPRS30H1()()</b>	To order please specify pattern number including:	H1 Height: Underside of overhead to top 1 1/2" thick desk height worksurface.
<b>R</b> Reff	1. Trim Finish: Painted or Anodized	*Installation instruction sheets available on-line.
<b>TP</b> Task Panel	2. Top insert finish: Fabric	For Task Panels refer to part number 6TP00085
<b>R</b> Tool rail	3. Bottom insert finish: Fabric	
<b>S</b> Segmented		Always supplied including cable curtain.
<b>30</b> Width		Always supplied including all trim pieces.
<b>H1</b> 23 1/8" high		LH & RH side full height trims. ( no hi-lo trims )
<b>111</b> Trim finish		All trims supplied with the same finish specification.
<b>W281</b> Fabric selection top		All Fabric to be applied railroaded as current tackboard
<b>W281</b> Fabric selection bottom		When ordering 54" or wider Task Panel, please check width of fabric specified.

# Task Panels

*H1 23 1/8" high*

*Segmented With Tool rail*

*Marker board Insert Above / Fabric Insert Below*

description	th	h	w	pattern no.	grade						
					LW10	LW15	LW20	LW30	LW35	LW40	LW45
Task Panel, segmented	1 1/2"	23 1/8"	30"	RTPRS30H1()()	\$1,154.	\$1,169.	\$1,183.	\$1,198.	\$1,234.	\$1,255.	\$1,284.
With tool rail	1 1/2"	23 1/8"	36"	RTPRS36H1()()	1,229.	1,247.	1,264.	1,282.	1,320.	1,343.	1,374.
	1 1/2"	23 1/8"	42"	RTPRS42H1()()	1,408.	1,429.	1,450.	1,471.	1,515.	1,541.	1,577.
	1 1/2"	23 1/8"	48"	RTPRS48H1()()	1,425.	1,448.	1,470.	1,493.	1,538.	1,565.	1,600.
	1 1/2"	23 1/8"	54"	RTPRS54H1()()	1,451.	1,477.	1,503.	1,529.	1,575.	1,602.	1,639.
	1 1/2"	23 1/8"	60"	RTPRS60H1()()	1,475.	1,504.	1,533.	1,562.	1,609.	1,637.	1,674.
	1 1/2"	23 1/8"	66"	RTPRS66H1()()	1,833.	1,864.	1,895.	1,926.	1,984.	2,018.	2,064.
	1 1/2"	23 1/8"	72"	RTPRS72H1()()	1,857.	1,891.	1,926.	1,960.	2,019.	2,054.	2,101.

Order Code	Specification Information	Application Notes
Example: <b>RTPRS30H1()()</b>	To order please specify pattern number including:	H1 Height: Underside of overhead to top 1 1/2" thick desk height worksurface.
<b>R</b> Reff	1. Trim Finish: Painted or Anodized	Installation instruction sheets available on line.
<b>TP</b> Task Panel	2. Top insert finish: Marker board	For Task Panels refer to part number 6TP00085.
<b>R</b> Tool rail	3. Bottom insert finish: Fabric	
<b>S</b> Segmentated		
<b>30</b> Width		Always supplied including all trim pieces.
<b>H1</b> 23 1/8" high		LH & RH side full height trims. ( no hi-lo trims )
<b>111</b> Trim finish		All trims supplied with the same finish specification.
<b>LW</b> Marker board top insert		All Fabric to be applied railroaded as current tackboard
<b>W281</b> Fabric selection bottom insert		When ordering 54" or wider Task Panel, please check width of fabric specified.

# Task Panels

*H1 23 1/8" high*

*Segmented With Tool rail*

*Glass or Fabric Insert Above / Forbo, Laminate or Wood Below*

description	th	h	w	pattern no.	G/FORB	FAB/FORB	FAB/L	FAB/V1	FAB/V2	FAB/V3
Task Panel, segmented	1 1/2"	23 1/8"	30"	RTPRS30H1()()	\$1,225.	\$1,101.	\$1,191.	\$1,234.	\$1,249.	\$1,281.
With tool rail	1 1/2"	23 1/8"	36"	RTPRS36H1()()	1,347.	985.	1,315.	1,315.	1,332.	1,371.
	1 1/2"	23 1/8"	42"	RTPRS42H1()()	1,573.	1,384.	1,459.	1,502.	1,521.	1,567.
	1 1/2"	23 1/8"	48"	RTPRS48H1()()	1,645.	1,412.	1,477.	1,557.	1,577.	1,629.
	1 1/2"	23 1/8"	54"	RTPRS54H1()()	1,714.	1,447.	1,505.	1,585.	1,606.	1,663.
	1 1/2"	23 1/8"	60"	RTPRS60H1()()	1,782.	1,483.	1,533.	1,613.	1,636.	1,699.
	1 1/2"	23 1/8"	66"	RTPRS66H1()()	2,171.	1,828.	1,902.	1,982.	2,008.	2,077.
	1 1/2"	23 1/8"	72"	RTPRS72H1()()	2,242.	1,866.	1,932.	2,013.	2,040.	2,116.
	1 1/2"	23 1/8"	78"	RTPRS78H1()()	2,415.	2,007.	2,064.	2,146.	2,175.	2,257.
	1 1/2"	23 1/8"	84"	RTPRS84H1()()	2,483.	2,031.	2,081.	2,163.	2,194.	2,283.
	1 1/2"	23 1/8"	90"	RTPRS90H1()()	2,552.	2,067.	2,109.	2,191.	2,224.	2,320.
	1 1/2"	23 1/8"	96"	RTPRS96H1()()	2,623.	2,104.	2,138.	2,221.	2,256.	2,358.

Order Code	Specification Information	Application Notes
Example: <b>RTPRS30H1()()</b>	To order please specify pattern number including:	H1 Height: Underside of overhead to top 1 1/2" thick desk height worksurface.
<b>R</b> Reff	1. Trim Finish: Painted or Anodized	*Installation instruction sheets available on-line.
<b>TP</b> Task Panel	2. Top insert finish: Glass or Fabric	For Task Panels refer to part number 6TP00085
<b>R</b> Tool rail	3. Bottom insert finish: Forbo, L, V1, V2, V3	Always supplied including cable curtain.
<b>S</b> Segmented		Always supplied including all trim pieces.
<b>30</b> Width		LH & RH side full height trims. ( no hi-lo trims )
<b>H1</b> 23 1/8" high		All trims supplied with the same finish specification.
<b>111</b> Trim finish		All Fabric to be applied railroaded as current tackboard
<b>W281</b> Fabric selection top insert		When ordering 54" or wider Task Panel, please check width of fabric specified.
<b>V319</b> Veneer selection bottom insert		

Task Panels  
*H2 29<sup>3</sup>/<sub>4</sub>" high*  
*Monolithic, Without Tool Rail*  
*Fabric*

Reff Profiles

description	th	h	w	pattern no.	grade						
					10	15	20	30	35	40	45
Task Panel, mono	1 1/2"	29 3/4"	30"	<b>RTPNM30H2( )()</b>	\$778.	\$793.	\$807.	\$822.	\$847.	\$861.	\$881.
Without tool rail	1 1/2"	29 3/4"	36"	<b>RTPNM36H2( )()</b>	832.	850.	868.	886.	913.	928.	950.
	1 1/2"	29 3/4"	42"	<b>RTPNM42H2( )()</b>	1,017.	1,038.	1,060.	1,081.	1,113.	1,133.	1,159.
	1 1/2"	29 3/4"	48"	<b>RTPNM48H2( )()</b>	1,031.	1,054.	1,076.	1,099.	1,132.	1,152.	1,178.
	1 1/2"	29 3/4"	54"	<b>RTPNM54H2( )()</b>	1,049.	1,075.	1,100.	1,126.	1,160.	1,180.	1,207.
	1 1/2"	29 3/4"	60"	<b>RTPNM60H2( )()</b>	1,110.	1,139.	1,169.	1,198.	1,234.	1,255.	1,284.
	1 1/2"	29 3/4"	66"	<b>RTPNM66H2( )()</b>	1,339.	1,370.	1,401.	1,432.	1,475.	1,501.	1,535.
	1 1/2"	29 3/4"	72"	<b>RTPNM72H2( )()</b>	1,359.	1,393.	1,427.	1,461.	1,505.	1,531.	1,566.
	1 1/2"	29 3/4"	78"	<b>RTPNM78H2( )()</b>	1,525.	1,562.	1,600.	1,637.	1,686.	1,715.	1,755.
	1 1/2"	29 3/4"	84"	<b>RTPNM84H2( )()</b>	1,536.	1,575.	1,614.	1,653.	1,702.	1,732.	1,772.
	1 1/2"	29 3/4"	90"	<b>RTPNM90H2( )()</b>	1,597.	1,639.	1,682.	1,724.	1,776.	1,807.	1,848.
	1 1/2"	29 3/4"	96"	<b>RTPNM96H2( )()</b>	1,617.	1,662.	1,708.	1,753.	1,805.	1,837.	1,879.

Order Code	Specification Information	Application Notes
Example: <b>RTPNM30H2( )()</b>	To order please specify pattern number including;	H2 Height: Underside of overhead to top 1" thick credenza top for 3/4 height cabinets or low credenza.
<b>R</b> Reff	1. Trim Finish: Painted or Anodized	Always supplied including cable curtain.
<b>TP</b> Task Panel	2. Top Insert Finish: Fabric	Always supplied including all trim pieces.
<b>N</b> No tool rail	3. Insert Finish: Fabric	LH & RH side full height trims. ( no hi-lo trims )
<b>M</b> Monolithic		All trims supplied with the same finish specification.
<b>30</b> Width		Tool rails are not supplied to this Task Panel.
<b>H2</b> 29 3/4" high		All Fabric to be applied railroaded as current tackboard.
<b>111</b> Trim finish		When ordering 54" or wider Task Panel, please check width of fabric specified.
<b>W281</b> Fabric selection		

Task Panels  
*H2 29<sup>3</sup>/<sub>4</sub>" high*  
*Monolithic, Without Tool Rail*  
*Wood, Laminate, Marker board or Glass Inserts*

Reff Profiles

description	th	h	w	pattern no.	glass	LW	L	V1	V2	V3
Task Panel, mono	1 1/2"	29 <sup>3</sup> / <sub>4</sub> "	30"	<b>RTPNM30H2</b> ( ) ( )	\$1,088.	\$793.	\$783.	\$884.	\$952.	\$1,129.
Without tool rail	1 1/2"	29 <sup>3</sup> / <sub>4</sub> "	36"	<b>RTPNM36H2</b> ( ) ( )	1,226.	845.	833.	936.	1,015.	1,226.
	1 1/2"	29 <sup>3</sup> / <sub>4</sub> "	42"	<b>RTPNM42H2</b> ( ) ( )	1,495.	1,023.	1,010.	1,116.	1,207.	1,453.
	1 1/2"	29 <sup>3</sup> / <sub>4</sub> "	48"	<b>RTPNM48H2</b> ( ) ( )	1,600.	1,045.	1,030.	1,138.	1,245.	1,525.
	1 1/2"	29 <sup>3</sup> / <sub>4</sub> "	54"	<b>RTPNM54H2</b> ( ) ( )	1,702.	1,056.	1,039.	1,150.	1,268.	1,583.
	1 1/2"	29 <sup>3</sup> / <sub>4</sub> "	60"	<b>RTPNM60H2</b> ( ) ( )	1,848.	1,112.	1,094.	1,206.	1,336.	1,686.
	1 1/2"	29 <sup>3</sup> / <sub>4</sub> "	66"	<b>RTPNM66H2</b> ( ) ( )	2,168.	1,373.	1,352.	1,468.	1,609.	1,993.
	1 1/2"	29 <sup>3</sup> / <sub>4</sub> "	72"	<b>RTPNM72H2</b> ( ) ( )	2,272.	1,387.	1,365.	1,482.	1,634.	2,052.
	1 1/2"	29 <sup>3</sup> / <sub>4</sub> "	78"	<b>RTPNM78H2</b> ( ) ( )	2,522.	1,553.	1,529.	1,649.	1,808.	2,260.
	1 1/2"	29 <sup>3</sup> / <sub>4</sub> "	84"	<b>RTPNM84H2</b> ( ) ( )	2,624.	1,565.	1,539.	1,662.	1,832.	2,319.
	1 1/2"	29 <sup>3</sup> / <sub>4</sub> "	90"	<b>RTPNM90H2</b> ( ) ( )	2,769.	1,627.	1,599.	1,752.	1,911.	2,432.
	1 1/2"	29 <sup>3</sup> / <sub>4</sub> "	96"	<b>RTPNM96H2</b> ( ) ( )	2,873.	1,641.	1,612.	1,739.	1,936.	2,491.

Accessories and Client Samples

Order Code	Specification Information	Application Notes
Example: <b>RTPNM30H2</b> ( ) ( )	To order please specify pattern number including;	H2 Height: Underside of overhead to top 1" thick credenza top for 3/4 height cabinets or low credenza.
<b>R</b> Reff	1. Trim Finish: Painted or Anodized	Always supplied including cable curtain.
<b>TP</b> Task Panel	2. Top Insert Finish: Fabric	Always supplied including all trim pieces.
<b>N</b> No tool rail	3. Bottom Insert Finish: G, LW, L, V1, V2, V3	LH & RH side full height trims. ( no hi-lo trims )
<b>M</b> Monolithic		All trims supplied with the same finish specification.
<b>30</b> Width		Tool rails are not supplied to this Task Panel.
<b>H2</b> 29 <sup>3</sup> / <sub>4</sub> " high		All Fabric to be applied railroded as current tackboard.
<b>111</b> Trim finish		When ordering 54" or wider Task Panel, please check width of fabric specified.
<b>V319</b> Veneer selection		

\*Installation instruction sheets available on-line.

For Task Panels refer to part number 6TP00085

Task Panels  
*H2 29<sup>3</sup>/<sub>4</sub>" high*  
*Segmented With Tool Rail*  
*Fabric Insert Above / Fabric Insert Below*

description	th	h	w	pattern no.	grade						
					10	15	20	30	35	40	45
Task Panel, segmented	1 1/2"	29 3/4"	30"	RTPRS30H2()()	\$1,223.	\$1,233.	\$1,244.	\$1,524.	\$1,292.	\$1,314.	\$1,344.
With tool rail	1 1/2"	29 3/4"	36"	RTPRS36H2()()	1,254.	1,290.	1,325.	1,361.	1,402.	1,426.	1,459.
	1 1/2"	29 3/4"	42"	RTPRS42H2()()	1,442.	1,484.	1,527.	1,569.	1,616.	1,644.	1,682.
	1 1/2"	29 3/4"	48"	RTPRS48H2()()	1,464.	1,509.	1,555.	1,600.	1,648.	1,677.	1,715.
	1 1/2"	29 3/4"	54"	RTPRS54H2()()	1,494.	1,546.	1,598.	1,650.	1,699.	1,729.	1,769.
	1 1/2"	29 3/4"	60"	RTPRS60H2()()	1,525.	1,583.	1,642.	1,700.	1,751.	1,781.	1,822.
	1 1/2"	29 3/4"	66"	RTPRS66H2()()	1,863.	1,924.	1,986.	2,047.	2,108.	2,145.	2,194.
	1 1/2"	29 3/4"	72"	RTPRS72H2()()	1,960.	2,009.	2,058.	2,107.	2,170.	2,208.	2,258.

Order Code	Specification Information	Application Notes
Example: <b>RTPRS30H2()()</b>	To order please specify pattern number including:	H2 Height: Underside of overhead to top 1" thick credenza top for 3/4 height cabinets or low credenza.
<b>R</b> Reff	1. Trim Finish: Painted or Anodized	Installation instruction sheets available on line.
<b>TP</b> Task Panel	2. Top Insert Finish: Fabric	Always supplied including cable curtain.
<b>R</b> Tool rail	3. Bottom Insert Finish: Fabric	Always supplied including all trim pieces.
<b>S</b> Segmented		LH & RH side full height trims. ( no hi-lo trims )
<b>30</b> Width		All trims supplied with the same finish specification.
<b>H2</b> 29 <sup>3</sup> / <sub>4</sub> " high		All Fabric to be applied railroaded as current tackboard.
<b>111</b> Trim finish		When ordering 54" or wider Task Panel, please check width of fabric specified.
<b>W281</b> Fabric selection top insert		
<b>W281</b> Fabric selection bottom insert		

Task Panels  
*H2 29<sup>3</sup>/<sub>4</sub>" high*  
*Segmented With Tool Rail*  
*Marker board Insert Above / Fabric Insert Below*

description	th	h	w	pattern no.	grade						
					LW10	LW15	LW20	LW30	LW35	LW40	LW45
Task Panel, segmented	1 1/2"	29 3/4"	30"	RTPRS30H2()()	\$1,172.	\$1,187.	\$1,201.	\$1,216.	\$1,252.	\$1,274.	\$1,303.
With tool rail	1 1/2"	29 3/4"	36"	RTPRS36H2()()	1,251.	1,269.	1,287.	1,305.	1,344.	1,368.	1,399.
	1 1/2"	29 3/4"	42"	RTPRS42H2()()	1,431.	1,452.	1,474.	1,495.	1,540.	1,567.	1,602.
	1 1/2"	29 3/4"	48"	RTPRS48H2()()	1,450.	1,473.	1,495.	1,518.	1,563.	1,591.	1,627.
	1 1/2"	29 3/4"	54"	RTPRS54H2()()	1,476.	1,502.	1,528.	1,554.	1,601.	1,628.	1,666.
	1 1/2"	29 3/4"	60"	RTPRS60H2()()	1,501.	1,530.	1,560.	1,589.	1,637.	1,665.	1,703.
	1 1/2"	29 3/4"	66"	RTPRS66H2()()	1,861.	1,892.	1,922.	1,953.	2,011.	2,047.	2,093.
	1 1/2"	29 3/4"	72"	RTPRS72H2()()	1,693.	1,794.	1,894.	1,995.	2,055.	2,091.	2,138.

Order Code	Specification Information	Application Notes
Example: <b>RTPRS30H2()()</b>	To order please specify pattern number including:	H2 Height: Underside of overhead to top 1" thick credenza top for 3/4 height cabinets or low credenza.
<b>R</b> Reff	1. Trim Finish: Painted or Anodized	*Installation instruction sheets available on-line.
<b>TP</b> Task Panel	2. Top Insert Finish: Marker board	For Task Panels refer to part number 6TP00085
<b>R</b> Tool rail	3. Bottom Insert Finish: Fabric	
<b>S</b> Segmented		
<b>30</b> Width		Always supplied including all trim pieces.
<b>H2</b> 29 3/4" high		LH & RH side full height trims. ( no hi-lo trims )
<b>111</b> Trim finish		All trims supplied with the same finish specification.
<b>LW</b> Marker board top insert		All Fabric to be applied railroaded as current tackboard.
<b>W281</b> Fabric selectin bottom insert		When ordering 54" or wider Task Panel, please check width of fabric specified.

# Task Panels

*H2 29<sup>3</sup>/<sub>4</sub>" high*

*Segmented With Tool Rail*

*Glass or Fabric Insert Above / Forbo, Laminate or Wood Below*

description	th	h	w	pattern no.	G/FORB	FAB/FORB	FAB/L	FAB/V1	FAB/V2	FAB/V3
Task Panel, segmented	1 1/2"	29 <sup>3</sup> / <sub>4</sub> "	30"	<b>RTPRS30H2</b> ( ) ( )	\$1,329.	\$1,121.	\$1,200.	\$126.	\$1,304.	\$1,377.
With tool rail	1 1/2"	29 <sup>3</sup> / <sub>4</sub> "	36"	<b>RTPRS36H2</b> ( ) ( )	1,473.	1,316.	1,287.	1,353.	1,397.	1,484.
	1 1/2"	29 <sup>3</sup> / <sub>4</sub> "	42"	<b>RTPRS42H2</b> ( ) ( )	1,717.	1,527.	1,479.	1,546.	1,594.	1,695.
	1 1/2"	29 <sup>3</sup> / <sub>4</sub> "	48"	<b>RTPRS48H2</b> ( ) ( )	1,807.	1,574.	1,500.	1,597.	1,649.	1,766.
	1 1/2"	29 <sup>3</sup> / <sub>4</sub> "	54"	<b>RTPRS54H2</b> ( ) ( )	1,894.	1,627.	1,530.	1,627.	1,684.	1,814.
	1 1/2"	29 <sup>3</sup> / <sub>4</sub> "	60"	<b>RTPRS60H2</b> ( ) ( )	1,980.	1,682.	1,560.	1,658.	1,719.	1,863.
	1 1/2"	29 <sup>3</sup> / <sub>4</sub> "	66"	<b>RTPRS66H2</b> ( ) ( )	2,387.	2,044.	1,922.	2,022.	2,087.	2,246.
	1 1/2"	29 <sup>3</sup> / <sub>4</sub> "	72"	<b>RTPRS72H2</b> ( ) ( )	2,483.	2,188.	1,965.	2,067.	2,132.	2,304.
	1 1/2"	29 <sup>3</sup> / <sub>4</sub> "	78"	<b>RTPRS78H2</b> ( ) ( )	2,668.	2,259.	2,093.	2,195.	2,264.	2,450.
	1 1/2"	29 <sup>3</sup> / <sub>4</sub> "	84"	<b>RTPRS84H2</b> ( ) ( )	2,754.	2,301.	2,114.	2,217.	2,291.	2,493.
	1 1/2"	29 <sup>3</sup> / <sub>4</sub> "	90"	<b>RTPRS90H2</b> ( ) ( )	2,841.	2,355.	2,144.	2,248.	2,327.	2,542.
	1 1/2"	29 <sup>3</sup> / <sub>4</sub> "	96"	<b>RTPRS96H2</b> ( ) ( )	2,929.	2,411.	2,175.	2,281.	2,363.	2,592.

Order Code	Specification Information	Application Notes
Example: <b>RTPRS30H2</b> ( ) ( )	To order please specify pattern number including:	H2 Height: Underside of overhead to top 1 <sup>7</sup> / <sub>8</sub> " thick credenza top for 3/4 height cabinets or low credenza.
<b>R</b> Reff	1. Trim Finish: Painted or Anodized	*Installation instruction sheets available on-line.
<b>TP</b> Task Panel	2. Top Insert Finish: Glass or Fabric	For Task Panels refer to part number 6TP00085
<b>R</b> Tool rail	3. Bottom Insert Finish: Forbo, L, V1, V2, V3	Always supplied including cable curtain.
<b>S</b> Segmented		Always supplied including all trim pieces.
<b>30</b> Width		LH & RH side full height trims. ( no hi-lo trims )
<b>H2</b> 29 <sup>3</sup> / <sub>4</sub> " high		All trims supplied with the same finish specification.
<b>111</b> Trim finish		All Fabric to be applied railroaded as current tackboard.
<b>W281</b> Fabric selectin top insert		When ordering 54" or wider Task Panel, please check width of fabric specified.
<b>V319</b> Veneer selection bottom insert		



Task Panels  
*H3 37<sup>7</sup>/<sub>8</sub>" high*  
*Monolithic, Without Tool rail*  
*Fabric*

Reff Profiles

description	th	h	w	pattern no.	grade						
					10	15	20	30	35	40	45
Task Panel, mono Without tool rail	1 1/2"	37 7/8"	30"	<b>RTPNM30H3( )()</b>	\$815.	\$829.	\$844.	\$858.	\$884.	\$899.	\$920.
	1 1/2"	37 7/8"	36"	<b>RTPNM36H3( )()</b>	870.	888.	905.	923.	951.	967.	989.
	1 1/2"	37 7/8"	42"	<b>RTPNM42H3( )()</b>	1,056.	1,077.	1,098.	1,119.	1,153.	1,173.	1,200.
	1 1/2"	37 7/8"	48"	<b>RTPNM48H3( )()</b>	1,071.	1,094.	1,116.	1,139.	1,173.	1,194.	1,221.
	1 1/2"	37 7/8"	54"	<b>RTPNM54H3( )()</b>	1,090.	1,116.	1,142.	1,168.	1,203.	1,224.	1,252.
	1 1/2"	37 7/8"	60"	<b>RTPNM60H3( )()</b>	1,152.	1,181.	1,211.	1,240.	1,277.	1,300.	1,329.
	1 1/2"	37 7/8"	66"	<b>RTPNM66H3( )()</b>	1,383.	1,414.	1,444.	1,475.	1,519.	1,546.	1,581.
	1 1/2"	37 7/8"	72"	<b>RTPNM72H3( )()</b>	1,403.	1,437.	1,472.	1,506.	1,551.	1,578.	1,614.
	1 1/2"	37 7/8"	78"	<b>RTPNM78H3( )()</b>	1,571.	1,608.	1,646.	1,683.	1,733.	1,764.	1,804.
	1 1/2"	37 7/8"	84"	<b>RTPNM84H3( )()</b>	1,583.	1,622.	1,661.	1,700.	1,751.	1,782.	1,822.
	1 1/2"	37 7/8"	90"	<b>RTPNM90H3( )()</b>	1,646.	1,688.	1,730.	1,772.	1,825.	1,857.	1,900.
	1 1/2"	37 7/8"	96"	<b>RTPNM96H3( )()</b>	1,666.	1,711.	1,757.	1,802.	1,856.	1,888.	1,932.

Accessories and Client Samples

Order Code	Specification Information	Application Notes
Example: <b>RTPNM30H3( )()</b>	To order please specify pattern number including;	H3 Height: Top of U-shelf or L-shelf overhead to top 1 1/2" thick desk height worksurface.
<b>R</b> Reff	1. Trim Finish: Painted or Anodized	*Installation instruction sheets available on-line.
<b>TP</b> Task Panel	2. Insert Finish: Fabric	For Task Panels refer to part number 6TP00085
<b>N</b> No tool rail		
<b>M</b> Monolithic		
<b>30</b> Width		Always supplied including all trim pieces.
<b>H3</b> 37 7/8" high		LH & RH side full height trims. ( no hi-lo trims )
<b>111</b> Trim finish		All trims supplied with the same finish specification.
<b>W281</b> Fabric selection		Tool rails are not supplied to this Task Panel.
		All Fabric to be applied railroaded as current tackboard.
		When ordering 54" or wider Task Panel, please check width of fabric specified.

# Task Panels

Reff Profiles

*H3 37<sup>7</sup>/<sub>8</sub>" high*

*Monolithic, Without Tool rail*

*Wood, Laminate, Marker board or Glass Inserts*

description	th	h	w	pattern no.	glass	LW	L	V1	V2	V3
Task Panel, mono	1 1/2"	37 <sup>7</sup> / <sub>8</sub> "	30"	<b>RTPNM30H3 ( ) ( )</b>	\$1,261.	\$842.	\$829.	\$934.	\$1,018.	\$1,247.
Without tool rail	1 1/2"	37 <sup>7</sup> / <sub>8</sub> "	36"	<b>RTPNM36H3 ( ) ( )</b>	1,428.	893.	878.	985.	1,085.	1,358.
	1 1/2"	37 <sup>7</sup> / <sub>8</sub> "	42"	<b>RTPNM42H3 ( ) ( )</b>	1,705.	1,082.	1,065.	1,175.	1,294.	1,611.
	1 1/2"	37 <sup>7</sup> / <sub>8</sub> "	48"	<b>RTPNM48H3 ( ) ( )</b>	1,860.	1,106.	1,087.	1,201.	1,334.	1,696.
	1 1/2"	37 <sup>7</sup> / <sub>8</sub> "	54"	<b>RTPNM54H3 ( ) ( )</b>	1,991.	1,121.	1,100.	1,216.	1,364.	1,770.
	1 1/2"	37 <sup>7</sup> / <sub>8</sub> "	60"	<b>RTPNM60H3 ( ) ( )</b>	2,166.	1,187.	1,163.	1,283.	1,441.	1,892.
	1 1/2"	37 <sup>7</sup> / <sub>8</sub> "	66"	<b>RTPNM66H3 ( ) ( )</b>	2,515.	1,444.	1,418.	1,541.	1,714.	2,209.
	1 1/2"	37 <sup>7</sup> / <sub>8</sub> "	72"	<b>RTPNM72H3 ( ) ( )</b>	2,648.	1,648.	1,439.	1,565.	1,758.	2,297.
	1 1/2"	37 <sup>7</sup> / <sub>8</sub> "	78"	<b>RTPNM78H3 ( ) ( )</b>	2,928.	1,631.	1,601.	1,729.	1,937.	2,520.
	1 1/2"	37 <sup>7</sup> / <sub>8</sub> "	84"	<b>RTPNM84H3 ( ) ( )</b>	3,058.	1,646.	1,613.	1,745.	1,967.	2,595.
	1 1/2"	37 <sup>7</sup> / <sub>8</sub> "	90"	<b>RTPNM90H3 ( ) ( )</b>	3,233.	1,705.	1,670.	1,805.	2,047.	2,729.
	1 1/2"	37 <sup>7</sup> / <sub>8</sub> "	96"	<b>RTPNM96H3 ( ) ( )</b>	3,366.	1,722.	1,684.	1,823.	2,073.	2,789.

Order Code	Specification Information	Application Notes
Example: <b>RTPNM30H3 ( ) ( )</b>	To order please specify pattern number including;	H3 Height: Top of U-shelf or L-shelf overhead to top 1 1/2" thick desk height worksurface.
<b>R</b> Reff	1. Trim Finish: Painted or Anodized	*Installation instruction sheets available on-line.
<b>TP</b> Task Panel	2. Insert Finish: G, LW, L, V1, V2, V3	For Task Panels refer to part number 6TP00085
<b>N</b> No tool rail		
<b>M</b> Monolithic		
<b>30</b> Width		Always supplied including all trim pieces.
<b>H3</b> 37 <sup>7</sup> / <sub>8</sub> " high		LH & RH side full height trims. ( no hi-lo trims )
<b>111</b> Trim finish		All trims supplied with the same finish specification.
<b>V319</b> Veneer selection		Tool rails are not supplied to this Task Panel.
		All Fabric to be applied railroded as current tackboard.
		When ordering 54" or wider Task Panel, please check width of fabric specified.

**Task Panels**  
*H3 37<sup>7</sup>/<sub>8</sub>" high*  
*Segmented With Tool rail*  
*Fabric Insert Above / Fabric Insert Below*

description	th	h	w	pattern no.	grade						
					10	15	20	30	35	40	45
Task Panel, segmented With tool rail	1 1/2"	37 7/8"	30"	<b>RTPRS30H3</b> ( ) ( )	\$1,206.	\$1,235.	\$1,265.	\$1,294.	\$1,333.	\$1,356.	\$1,387.
	1 1/2"	37 7/8"	36"	<b>RTPRS36H3</b> ( ) ( )	1,291.	1,327.	1,362.	1,398.	1,440.	1,465.	1,498.
	1 1/2"	37 7/8"	42"	<b>RTPRS42H3</b> ( ) ( )	1,481.	1,523.	1,566.	1,608.	1,656.	1,685.	1,724.
	1 1/2"	37 7/8"	48"	<b>RTPRS48H3</b> ( ) ( )	1,503.	1,548.	1,594.	1,639.	1,688.	1,718.	1,757.
	1 1/2"	37 7/8"	54"	<b>RTPRS54H3</b> ( ) ( )	1,535.	1,587.	1,639.	1,691.	1,742.	1,772.	1,813.
	1 1/2"	37 7/8"	60"	<b>RTPRS60H3</b> ( ) ( )	1,567.	1,626.	1,684.	1,743.	1,795.	1,826.	1,868.
	1 1/2"	37 7/8"	66"	<b>RTPRS66H3</b> ( ) ( )	1,906.	1,968.	2,029.	2,091.	2,154.	2,191.	2,241.
	1 1/2"	37 7/8"	72"	<b>RTPRS72H3</b> ( ) ( )	1,941.	2,009.	2,077.	2,145.	2,209.	2,248.	2,299.

Accessories and Client Samples

Order Code	Specification Information	Application Notes
Example: <b>RTPRS30H3</b> ( ) ( )	To order please specify pattern number including:	H3 Height: Top of U-shelf or L-shelf overhead to top 1 1/2" thick desk height worksurface.
<b>R</b> Reff	1. Trim Finish: Painted or Anodized	*Installation instruction sheets available on-line.
<b>TP</b> Task Panel	2. Top Insert Finish: Fabric	For Task Panels refer to part number 6TP00085
<b>R</b> Tool rail	3. Bottom Insert Finish: Fabric	
<b>S</b> Segmented		Always supplied including cable curtain.
<b>30</b> Width		Always supplied including all trim pieces.
<b>H3</b> 37 7/8" high		LH & RH side full height trims. ( no hi-lo trims )
<b>111</b> Trim finish		All trims supplied with the same finish specification.
<b>W281</b> Fabric selection top insert		All Fabric to be applied railroded as current tackboard.
<b>W281</b> Fabric selection bottom insert		When ordering 54" or wider Task Panel, please check width of fabric specified.

# Task Panels

*H3 37<sup>7</sup>/<sub>8</sub>" high*

*Segmented With Tool rail*

*Marker Board Insert Above / Fabric Insert Below*

description	th	h	w	pattern no.	grade						
					LW10	LW15	LW20	LW30	LW35	LW40	LW45
Task Panel, segmented	1 1/2"	37 7/8"	30"	RTPRS30H3()()	\$1,238.	\$1,252.	\$1,267.	\$1,281.	\$1,319.	\$1,342.	\$1,373.
With tool rail	1 1/2"	37 7/8"	36"	RTPRS36H3()()	1,318.	1,336.	1,354.	1,372.	1,413.	1,438.	1,471.
	1 1/2"	37 7/8"	42"	RTPRS42H3()()	1,509.	1,530.	1,552.	1,573.	1,620.	1,648.	1,686.
	1 1/2"	37 7/8"	48"	RTPRS48H3()()	1,532.	1,555.	1,578.	1,601.	1,649.	1,678.	1,716.
	1 1/2"	37 7/8"	54"	RTPRS54H3()()	1,566.	1,592.	1,618.	1,644.	1,693.	1,723.	1,762.
	1 1/2"	37 7/8"	60"	RTPRS60H3()()	1,593.	1,622.	1,652.	1,681.	1,731.	1,762.	1,802.
	1 1/2"	37 7/8"	66"	RTPRS66H3()()	1,958.	1,989.	2,019.	2,050.	2,111.	2,148.	2,197.
	1 1/2"	37 7/8"	72"	RTPRS72H3()()	1,993.	2,027.	2,061.	2,095.	2,158.	2,195.	2,246.

Order Code	Specification Information	Application Notes
Example: <b>RTPRS30H3()()</b>	To order please specify pattern number including:	H3 Height: Top of U-shelf or L-shelf overhead to top 1 1/2" thick desk height worksurface.
<b>R</b> Reff	1. Trim Finish: Painted or Anodized	*Installation instruction sheets available on-line.
<b>TP</b> Task Panel	2. Top Insert Finish: Marker board	For Task Panels refer to part number 6TP00085
<b>R</b> Tool rail	3. Bottom Insert Finish: Fabric	
<b>S</b> Segmented		
<b>30</b> Width		Always supplied including all trim pieces.
<b>H3</b> 37 7/8" high		LH & RH side full height trims. ( no hi-lo trims )
<b>111</b> Trim finish		All trims supplied with the same finish specification.
<b>LW</b> Marker board top insert		All Fabric to be applied railroaded as current tackboard.
<b>W281</b> Fabric selection bottom insert		When ordering 54" or wider Task Panel, please check width of fabric specified.

# Task Panels

*H3 37<sup>7</sup>/<sub>8</sub>" high*

*Segmented With Tool rail*

*Glass or Fabric Insert Above / Forbo, Laminate or Wood Below*

description	th	h	w	pattern no.	G/FORB	FAB/FORB	FAB/L	FAB/V1	FAB/V2	FAB/V3
Task Panel, segmented	1 1/2"	37 <sup>7</sup> / <sub>8</sub> "	30"	RTPRS30H3( ) ( )	\$1,543.	\$1,159.	\$1,249.	\$1,292.	\$1,306.	\$1,339.
With tool rail	1 1/2"	37 <sup>7</sup> / <sub>8</sub> "	36"	RTPRS36H3( ) ( )	1,719.	1,250.	1,332.	1,375.	1,392.	1,431.
	1 1/2"	37 <sup>7</sup> / <sub>8</sub> "	42"	RTPRS42H3( ) ( )	1,999.	1,446.	1,521.	1,565.	1,583.	1,629.
	1 1/2"	37 <sup>7</sup> / <sub>8</sub> "	48"	RTPRS48H3( ) ( )	2,126.	1,476.	1,542.	1,621.	1,641.	1,693.
	1 1/2"	37 <sup>7</sup> / <sub>8</sub> "	54"	RTPRS54H3( ) ( )	2,249.	1,514.	1,571.	1,651.	1,672.	1,729.
	1 1/2"	37 <sup>7</sup> / <sub>8</sub> "	60"	RTPRS60H3( ) ( )	2,372.	1,552.	1,601.	1,681.	1,705.	1,768.
	1 1/2"	37 <sup>7</sup> / <sub>8</sub> "	66"	RTPRS66H3( ) ( )	2,815.	1,898.	1,973.	2,053.	2,078.	2,148.
	1 1/2"	37 <sup>7</sup> / <sub>8</sub> "	72"	RTPRS72H3( ) ( )	2,941.	1,939.	2,005.	2,086.	2,113.	2,189.
	1 1/2"	37 <sup>7</sup> / <sub>8</sub> "	78"	RTPRS78H3( ) ( )	3,168.	2,082.	2,139.	2,221.	2,250.	2,333.
	1 1/2"	37 <sup>7</sup> / <sub>8</sub> "	84"	RTPRS84H3( ) ( )	3,291.	2,008.	2,158.	2,241.	2,271.	2,360.
	1 1/2"	37 <sup>7</sup> / <sub>8</sub> "	90"	RTPRS90H3( ) ( )	3,414.	2,146.	2,188.	2,271.	2,304.	2,399.
	1 1/2"	37 <sup>7</sup> / <sub>8</sub> "	96"	RTPRS96H3( ) ( )	3,539.	2,186.	2,220.	2,303.	2,338.	2,439.

Order Code	Specification Information	Application Notes
Example: <b>RTPRS30H3( ) ( )</b>	To order please specify pattern number including:	H3 Height: Top of U-shelf or L-shelf overhead to top 1 1/2" thick desk height worksurface.
<b>R</b> Reff	1. Trim Finish: Painted or Anodized	*Installation instruction sheets available on-line.
<b>TP</b> Task Panel	2. Top Insert Finish: Glass or Fabric	For Task Panels refer to part number 6TP00085
<b>R</b> Tool rail	3. Bottom Insert Finish: Forbo, L, V1, V2, V3	Always supplied including cable curtain.
<b>S</b> Segmented		Always supplied including all trim pieces.
<b>30</b> Width		LH & RH side full height trims. ( no hi-lo trims )
<b>H3</b> 37 <sup>7</sup> / <sub>8</sub> " high		All trims supplied with the same finish specification.
<b>111</b> Trim finish		All Fabric to be applied railroaded as current tackboard.
<b>W281</b> Fabric selection top		When ordering 54" or wider Task Panel, please check width of fabric specified.
<b>V319</b> Veneer selection bottom		

Task Panels  
*H4 44 1/2" high*  
*Monolithic, Without Tool rail*  
*Fabric*

description	th	h	w	pattern no.	grade						
					10	15	20	30	35	40	45
Task Panel, mono without tool rail	1 1/2"	44 1/2"	30"	<b>RTPNM30H4( )()</b>	\$881.	\$895.	\$910.	\$924.	\$952.	\$968.	\$991.
	1 1/2"	44 1/2"	36"	<b>RTPNM36H4( )()</b>	937.	955.	972.	990.	1,020.	1,038.	1,061.
	1 1/2"	44 1/2"	42"	<b>RTPNM42H4( )()</b>	1,124.	1,145.	1,166.	1,187.	1,223.	1,244.	1,272.
	1 1/2"	44 1/2"	48"	<b>RTPNM48H4( )()</b>	1,140.	1,163.	1,185.	1,208.	1,244.	1,266.	1,295.
	1 1/2"	44 1/2"	54"	<b>RTPNM54H4( )()</b>	1,160.	1,186.	1,212.	1,238.	1,275.	1,297.	1,327.
	1 1/2"	44 1/2"	60"	<b>RTPNM60H4( )()</b>	1,223.	1,252.	1,282.	1,311.	1,350.	1,374.	1,405.
	1 1/2"	44 1/2"	66"	<b>RTPNM66H4( )()</b>	1,455.	1,486.	1,516.	1,547.	1,593.	1,621.	1,658.
	1 1/2"	44 1/2"	72"	<b>RTPNM72H4( )()</b>	1,477.	1,511.	1,545.	1,579.	1,626.	1,655.	1,693.
	1 1/2"	44 1/2"	78"	<b>RTPNM78H4( )()</b>	1,645.	1,622.	1,598.	1,575.	1,622.	1,651.	1,688.
	1 1/2"	44 1/2"	84"	<b>RTPNM84H4( )()</b>	1,658.	1,697.	1,736.	1,775.	1,828.	1,860.	1,903.
	1 1/2"	44 1/2"	90"	<b>RTPNM90H4( )()</b>	1,721.	1,763.	1,806.	1,848.	1,903.	1,937.	1,981.
	1 1/2"	44 1/2"	96"	<b>RTPNM96H4( )()</b>	1,743.	1,788.	1,834.	1,879.	1,935.	1,969.	2,014.

Order Code	Specification Information	Application Notes
Example: <b>RTPNM30H4( )()</b>	To order please specify pattern number including;	H4 Height: Top of U-shelf or L-shelf overhead to top 1" thick credenza top for 3/4 height cabinet or low credenza.
<b>R</b> Reff	1. Trim Finish: Painted or Anodized	*Installation instruction sheets available on-line.
<b>TP</b> Task Panel	2. Insert Finish: Fabric	For Task Panels refer to part number 6TP00085
<b>N</b> No tool rail		
<b>M</b> Monolithic		Always supplied including cable curtain.
<b>30</b> Width		Always supplied including all trim pieces.
<b>H4</b> 44 1/2" high		LH & RH side full height trims. ( no hi-lo trims )
<b>111</b> Trim finish		All trims supplied with the same finish specification.
<b>W281</b> Fabric selection		Tool rails are not supplied to this Task Panel.
		All Fabric to be applied railroaded as current tackboard.
		When ordering 54" or wider Task Panel, please check width of fabric specified.

# Task Panels

Reff Profiles

*H4 44 1/2" high*

*Monolithic, Without Tool rail*

*Wood, Laminate, Marker board or Glass Inserts*

description	th	h	wi	pattern no.	glass	LW	L	V1	V2	V3	
Task Panel, mono without tool rail	1 1/2"	44 1/2"	30"	<b>RTPNM30H4 ( )</b>		\$1,431.	\$917.	\$902.	\$1,009.	\$1,108.	\$1,378.
	1 1/2"	44 1/2"	36"	<b>RTPNM36H4 ( )</b>		1,620.	977.	960.	1,070.	1,191.	1,378.
	1 1/2"	44 1/2"	42"	<b>RTPNM42H4 ( )</b>		1,915.	1,170.	1,150.	1,263.	1,402.	1,776.
	1 1/2"	44 1/2"	48"	<b>RTPNM48H4 ( )</b>		2,096.	1,189.	1,167.	1,285.	1,440.	1,866.
	1 1/2"	44 1/2"	54"	<b>RTPNM54H4 ( )</b>		2,249.	1,214.	1,189.	1,310.	1,478.	1,957.
	1 1/2"	44 1/2"	60"	<b>RTPNM60H4 ( )</b>		2,446.	1,275.	1,247.	1,372.	1,557.	2,087.
	1 1/2"	44 1/2"	66"	<b>RTPNM66H4 ( )</b>		2,817.	1,542.	1,511.	1,640.	1,847.	2,430.
	1 1/2"	44 1/2"	72"	<b>RTPNM72H4 ( )</b>		2,971.	1,562.	1,528.	1,660.	1,885.	2,521.
	1 1/2"	44 1/2"	78"	<b>RTPNM78H4 ( )</b>		3,273.	1,727.	1,691.	1,827.	2,069.	2,756.
	1 1/2"	44 1/2"	84"	<b>RTPNM84H4 ( )</b>		3,425.	1,745.	1,706.	1,846.	2,105.	2,845.
	1 1/2"	44 1/2"	90"	<b>RTPNM90H4 ( )</b>		3,622.	1,765.	1,806.	1,908.	2,184.	2,976.
	1 1/2"	44 1/2"	96"	<b>RTPNM96H4 ( )</b>		3,776.	1,825.	1,781.	1,929.	2,222.	3,067.

Accessories and Client Samples

Order Code	Specification Information	Application Notes
Example: <b>RTPNM30H4 ( )</b>	To order please specify pattern number including;	H4 Height: Top of U-shelf or L-shelf overhead to top 1" thick credenza top for 3/4 height cabinet or low credenza.
<b>R</b> Reff	1. Trim Finish: Painted or Anodized	*Installation instruction sheets available on-line.
<b>TP</b> Task Panel	2. Insert Finish: Fabric	For Task Panels refer to part number 6TP00085
<b>N</b> No tool rail		
<b>M</b> Monolithic		Always supplied including cable curtain.
<b>30</b> Width		Always supplied including all trim pieces.
<b>H4</b> 44 1/2" high		LH & RH side full height trims. ( no hi-lo trims )
<b>111</b> Trim finish		All trims supplied with the same finish specification.
<b>V319</b> Veneer selection		Tool rails are not supplied to this Task Panel.
		All Fabric to be applied railroded as current tackboard.
		When ordering 54" or wider Task Panel, please check width of fabric specified.

# Task Panels

*H4 44 1/2" high*

*Segmented With Tool rail*

*Fabric Insert Above / Fabric Insert Below*

description	th	h	w	pattern no.	grade						
					10	15	20	30	35	40	45
Task Panel, segmented With tool rail	1 1/2"	44 1/2"	30"	RTPRS30H4()()	\$1,272.	\$1,301.	\$1,331.	\$1,360.	\$1,401.	\$1,424.	\$1,458.
	1 1/2"	44 1/2"	36"	RTPRS36H4()()	1,359.	1,395.	1,430.	1,466.	1,510.	1,536.	1,571.
	1 1/2"	44 1/2"	42"	RTPRS42H4()()	1,549.	1,591.	1,634.	1,676.	1,726.	1,756.	1,796.
	1 1/2"	44 1/2"	48"	RTPRS48H4()()	1,572.	1,618.	1,663.	1,709.	1,760.	1,791.	1,832.
	1 1/2"	44 1/2"	54"	RTPRS54H4()()	1,605.	1,657.	1,709.	1,761.	1,814.	1,845.	1,888.
	1 1/2"	44 1/2"	60"	RTPRS60H4()()	1,638.	1,697.	1,755.	1,814.	1,868.	1,901.	1,944.
	1 1/2"	44 1/2"	66"	RTPRS66H4()()	1,978.	2,040.	2,101.	2,163.	2,228.	2,267.	2,318.
	1 1/2"	44 1/2"	72"	RTPRS72H4()()	2,013.	2,081.	2,150.	2,218.	2,284.	2,324.	2,377.

Order Code	Specification Information	Application Notes
Example: <b>RTPRS30H4()()</b>	To order please specify pattern number including;	H4 Height: Top of U-shelf or L-shelf overhead to top 1" thick credenza top for 3/4 height cabinet or low credenza.
<b>R</b> Reff	1. Trim Finish: Painted or Anodized	*Installation instruction sheets available on-line.
<b>TP</b> Task Panel	2. Top Insert Finish: Fabric	For Task Panels refer to part number 6TP00085
<b>R</b> Tool rail	3. Bottom Insert Finish: Fabric	Always supplied including cable curtain.
<b>S</b> Segmented		Always supplied including all trim pieces.
<b>30</b> Width		LH & RH side full height trims. ( no hi-lo trims )
<b>H4</b> 44 1/2" high		All trims supplied with the same finish specification.
<b>111</b> Trim finish		All Fabric to be applied railroaded as current tackboard.
<b>W281</b> Fabric selection top		When ordering 54" or wider Task Panel, please check width of fabric specified.
<b>W281</b> Fabric selection bottom		



# Task Panels

*H4 44 1/2" high*

*Segmented With Tool rail*

*Marker Board Insert Above / Fabric Insert Below*

description	th	h	w	pattern no.	grade						
					LW10	LW15	LW20	LW30	LW35	LW40	LW45
Task Panel, segmented With tool rail	1 1/2"	44 1/2"	30"	RTPRS30H4()()	\$1,304.	\$1,319.	\$1,333.	\$1,348.	\$1,388.	\$1,413.	\$1,445.
	1 1/2"	44 1/2"	36"	RTPRS36H4()()	1,385.	1,403.	1,421.	1,439.	1,482.	1,508.	1,542.
	1 1/2"	44 1/2"	42"	RTPRS42H4()()	1,578.	1,599.	1,620.	1,641.	1,690.	1,720.	1,759.
	1 1/2"	44 1/2"	48"	RTPRS48H4()()	1,602.	1,625.	1,647.	1,670.	1,720.	1,750.	1,790.
	1 1/2"	44 1/2"	54"	RTPRS54H4()()	1,636.	1,662.	1,688.	1,714.	1,765.	1,796.	1,837.
	1 1/2"	44 1/2"	60"	RTPRS60H4()()	1,664.	1,693.	1,723.	1,752.	1,804.	1,836.	1,878.
	1 1/2"	44 1/2"	66"	RTPRS66H4()()	2,030.	2,061.	2,091.	2,122.	2,186.	2,224.	2,274.
	1 1/2"	44 1/2"	72"	RTPRS72H4()()	2,066.	2,100.	2,134.	2,168.	2,233.	2,272.	2,324.

Order Code	Specification Information	Application Notes
Example: <b>RTPRS30H4()()</b>	To order please specify pattern number including;	H4 Height: Top of U-shelf or L-shelf overhead to top 1" thick credenza top for 3/4 height cabinet or low credenza.
<b>R</b> Reff	1. Trim Finish: Painted or Anodized	*Installation instruction sheets available on-line.
<b>TP</b> Task Panel	2. Top Insert Finish: Marker board	For Task Panels refer to part number 6TP00085
<b>R</b> Tool rail	3. Bottom Insert Finish: Fabric	
<b>S</b> Segmented		Always supplied including cable curtain.
<b>30</b> Width		Always supplied including all trim pieces.
<b>H4</b> 44 1/2" high		LH & RH side full height trims. ( no hi-lo trims )
<b>111</b> Trim finish		All trims supplied with the same finish specification.
<b>LW</b> Marker Board top insert		All Fabric to be applied railroaded as current tackboard.
<b>W281</b> Fabric selection bottom insert		When ordering 54" or wider Task Panel, please check width of fabric specified.

# Task Panels

*H4 44 1/2" high*

*Segmented With Tool rail*

*Glass or Fabric Insert Above / Forbo, Laminate or Wood Below*

description	th	h	w	pattern no.	G/FORB	FAB/FORB	FAB/L	FAB/V1	FAB/V2	FAB/V3
Task Panel, segmented	1 1/2"	44 1/2"	30"	<b>RTPRS30H4</b> ( ) ( )	\$1,695.	\$1,311.	\$1,307.	\$1,372.	\$1,410.	\$1,483.
With tool rail	1 1/2"	44 1/2"	36"	<b>RTPRS36H4</b> ( ) ( )	1,889.	1,420.	1,392.	1,458.	1,501.	1,589.
	1 1/2"	44 1/2"	42"	<b>RTPRS42H4</b> ( ) ( )	2,188.	1,634.	1,586.	1,653.	1,701.	1,802.
	1 1/2"	44 1/2"	48"	<b>RTPRS48H4</b> ( ) ( )	2,333.	1,682.	1,609.	1,706.	1,758.	1,874.
	1 1/2"	44 1/2"	54"	<b>RTPRS54H4</b> ( ) ( )	2,474.	1,739.	1,641.	1,739.	1,795.	1,926.
	1 1/2"	44 1/2"	60"	<b>RTPRS60H4</b> ( ) ( )	2,615.	1,795.	1,673.	1,772.	1,833.	1,976.
	1 1/2"	44 1/2"	66"	<b>RTPRS66H4</b> ( ) ( )	3,076.	2,159.	2,037.	2,132.	2,203.	2,362.
	1 1/2"	44 1/2"	72"	<b>RTPRS72H4</b> ( ) ( )	3,220.	2,218.	2,071.	2,173.	2,242.	2,415.
	1 1/2"	44 1/2"	78"	<b>RTPRS78H4</b> ( ) ( )	3,465.	2,379.	2,213.	2,315.	2,384.	2,570.
	1 1/2"	44 1/2"	84"	<b>RTPRS84H4</b> ( ) ( )	3,607.	2,423.	2,236.	2,339.	2,413.	2,615.
	1 1/2"	44 1/2"	90"	<b>RTPRS90H4</b> ( ) ( )	3,748.	2,480.	2,268.	2,372.	2,451.	2,666.
	1 1/2"	44 1/2"	96"	<b>RTPRS96H4</b> ( ) ( )	3,891.	2,538.	2,301.	2,407.	2,490.	2,718.

Order Code	Specification Information	Application Notes
Example: <b>RTPRS30H4</b> ( ) ( )	To order please specify pattern number including;	H4 Height: Top of U-shelf or L-shelf overhead to top 1" thick credenza top for 3/4 height cabinet or low credenza.
<b>R</b> Reff	1. Trim Finish: Painted or Anodized	*Installation instruction sheets available on-line.
<b>TP</b> Task Panel	2. Top Insert Finish: Glass or Fabric	For Task Panels refer to part number 6TP00085
<b>R</b> Tool rail	3. Bottom Insert Finish: Forbo, L, V1, V2, V3	Always supplied including cable curtain.
<b>S</b> Segmented		Always supplied including all trim pieces.
<b>30</b> Width		LH & RH side full height trims. ( no hi-lo trims )
<b>H4</b> 44 1/2" high		All trims supplied with the same finish specification.
<b>111</b> Trim finish		All Fabric to be applied railroaded as current tackboard.
<b>W281</b> Fabric selection top insert		When ordering 54" or wider Task Panel, please check width of fabric specified.
<b>V319</b> Veneer selection bottom insert		

Task Panels  
*H5 42<sup>5</sup>/<sub>8</sub>" high*  
*Monolithic, Without Tool rail*  
*Fabric*

Reff Profiles

description	th	h	w	pattern no.	grade						
					10	15	20	30	35	40	45
Task Panel, mono without tool rail	1 1/2"	42 5/8"	30"	RTPNM30H5( )()	\$871.	\$886.	\$900.	\$915.	\$942.	\$959.	\$981.
	1 1/2"	42 5/8"	36"	RTPNM36H5( )()	927.	945.	963.	981.	1,010.	1,028.	1,052.
	1 1/2"	42 5/8"	42"	RTPNM42H5( )()	1,114.	1,135.	1,156.	1,177.	1,212.	1,233.	1,262.
	1 1/2"	42 5/8"	48"	RTPNM48H5( )()	1,130.	1,153.	1,175.	1,198.	1,234.	1,256.	1,284.
	1 1/2"	42 5/8"	54"	RTPNM54H5( )()	1,149.	1,175.	1,201.	1,227.	1,264.	1,286.	1,315.
	1 1/2"	42 5/8"	60"	RTPNM60H5( )()	1,212.	1,241.	1,271.	1,300.	1,339.	1,362.	1,394.
	1 1/2"	42 5/8"	66"	RTPNM66H5( )()	1,444.	1,475.	1,505.	1,536.	1,582.	1,610.	1,647.
	1 1/2"	42 5/8"	72"	RTPNM72H5( )()	1,465.	1,499.	1,533.	1,567.	1,614.	1,642.	1,680.
	1 1/2"	42 5/8"	78"	RTPNM78H5( )()	1,633.	1,670.	1,708.	1,745.	1,797.	1,829.	1,871.
	1 1/2"	42 5/8"	84"	RTPNM84H5( )()	1,646.	1,685.	1,724.	1,763.	1,816.	1,848.	1,890.
	1 1/2"	42 5/8"	90"	RTPNM90H5( )()	1,709.	1,751.	1,794.	1,836.	1,891.	1,924.	1,968.
	1 1/2"	42 5/8"	96"	RTPNM96H5( )()	1,731.	1,775.	1,820.	1,864.	1,920.	1,953.	1,998.

Accessories and Client  
Samples

Order Code	Specification Information	Application Notes
Example: <b>RTPNM30H5( )()</b>	To order please specify pattern number including;	H5 Height: Top of single high overhead to top of 1 1/2" thick desk height worksurface.
<b>R</b> Reff	1. Trim Finish: Painted or Anodized	Always supplied including cable curtain.
<b>TP</b> Task Panel	2. Insert Finish: Fabric	Always supplied including all trim pieces.
<b>N</b> No tool rail		LH & RH side full height trims. ( no hi-lo trims )
<b>M</b> Monolithic		All trims supplied with the same finish specification.
<b>30</b> Width		Tool rails are not supplied to this Task Panel.
<b>H5</b> 42 5/8" high		All Fabric to be applied railroaded as current tackboard.
<b>111</b> Trim finish		When ordering 54" or wider Task Panel, please check width of fabric specified.
<b>W281</b> Fabric selection		

\*Installation instruction sheets available on-line.

For Task Panels refer to part number 6TP00085

# Task Panels

*H5 42<sup>5</sup>/<sub>8</sub>" high*

*Monolithic, Without Tool rail*

*Wood, Laminate, Marker board or Glass Inserts*

description	th	h	w	pattern no.	glass	LW	L	V1	V2	V3
Task Panel, mono without tool rail	1 1/2"	42 <sup>5</sup> / <sub>8</sub> "	30"	<b>RTPNM30H5( )</b> ( )	\$1,405.	\$905.	\$891.	\$997.	\$1,092.	\$1,350.
	1 1/2"	42 <sup>5</sup> / <sub>8</sub> "	36"	<b>RTPNM36H5( )</b> ( )	1,590.	964.	948.	1,058.	1,174.	1,482.
	1 1/2"	42 <sup>5</sup> / <sub>8</sub> "	42"	<b>RTPNM42H5( )</b> ( )	1,882.	1,156.	1,136.	1,250.	1,382.	1,741.
	1 1/2"	42 <sup>5</sup> / <sub>8</sub> "	48"	<b>RTPNM48H5( )</b> ( )	2,059.	1,175.	1,154.	1,270.	1,420.	1,828.
	1 1/2"	42 <sup>5</sup> / <sub>8</sub> "	54"	<b>RTPNM54H5( )</b> ( )	2,208.	1,199.	1,175.	1,295.	1,456.	1,914.
	1 1/2"	42 <sup>5</sup> / <sub>8</sub> "	60"	<b>RTPNM60H5( )</b> ( )	2,401.	1,260.	1,233.	1,356.	1,534.	2,042.
	1 1/2"	42 <sup>5</sup> / <sub>8</sub> "	66"	<b>RTPNM66H5( )</b> ( )	2,769.	1,526.	1,496.	1,623.	1,823.	2,383.
	1 1/2"	42 <sup>5</sup> / <sub>8</sub> "	72"	<b>RTPNM72H5( )</b> ( )	2,920.	1,545.	1,513.	1,643.	1,859.	2,469.
	1 1/2"	42 <sup>5</sup> / <sub>8</sub> "	78"	<b>RTPNM78H5( )</b> ( )	3,217.	1,710.	1,675.	1,809.	2,042.	2,701.
	1 1/2"	42 <sup>5</sup> / <sub>8</sub> "	84"	<b>RTPNM84H5( )</b> ( )	3,366.	1,727.	1,690.	1,827.	2,076.	2,786.
	1 1/2"	42 <sup>5</sup> / <sub>8</sub> "	90"	<b>RTPNM90H5( )</b> ( )	3,559.	1,787.	1,747.	1,888.	2,154.	2,913.
	1 1/2"	42 <sup>5</sup> / <sub>8</sub> "	96"	<b>RTPNM96H5( )</b> ( )	3,710.	1,805.	1,763.	1,908.	2,190.	3,018.

Order Code	Specification Information	Application Notes
Example: <b>RTPNM30H5( )</b> ( )	To order please specify pattern number including;	H5 Height: Top of single high overhead to top of 1 1/2" thick desk height work worksurface.
<b>R</b> Reff	1. Trim Finish: Painted or Anodized	*Installation instruction sheets available on-line.
<b>TP</b> Task Panel	2. Insert Finish: G, LW, L, V1, V2, V3	For Task Panels refer to part number 6TP00085
<b>N</b> No tool rail		Always supplied including cable curtain.
<b>M</b> Monolithic		Always supplied including all trim pieces.
<b>30</b> Width		LH & RH side full height trims. ( no hi-lo trims )
<b>H5</b> 42 <sup>5</sup> / <sub>8</sub> " high		All trims supplied with the same finish specification.
<b>111</b> Trim finish		Tool rails are not supplied to this Task Panel.
<b>V319</b> Veneer selection		All Fabric to be applied railroded as current tackboard
		When ordering 54" or wider Task Panel, please check width of fabric specified.

Task Panels  
*H5 42<sup>5</sup>/<sub>8</sub>" high*  
*Segmented With Tool rail*  
*Fabric Insert Above / Fabric Insert Below*

description	th	h	w	pattern no.	grade						
					10	15	20	30	35	40	45
Task Panel, segmented	1 1/2"	42 5/8"	30"	RTPRS30H5()()	\$1,263.	\$1,292.	\$1,321.	\$1,350.	\$1,390.	\$1,415.	\$1,447.
With tool rail	1 1/2"	42 5/8"	36"	RTPRS36H5()()	1,349.	1,385.	1,420.	1,456.	1,500.	1,526.	1,561.
	1 1/2"	42 5/8"	42"	RTPRS42H5()()	1,539.	1,581.	1,624.	1,666.	1,716.	1,746.	1,786.
	1 1/2"	42 5/8"	48"	RTPRS48H5()()	1,562.	1,607.	1,653.	1,698.	1,749.	1,779.	1,820.
	1 1/2"	42 5/8"	54"	RTPRS54H5()()	1,595.	1,647.	1,699.	1,751.	1,803.	1,835.	1,877.
	1 1/2"	42 5/8"	60"	RTPRS60H5()()	1,627.	1,686.	1,744.	1,803.	1,857.	1,889.	1,933.
	1 1/2"	42 5/8"	66"	RTPRS66H5()()	1,967.	2,029.	2,090.	2,152.	2,216.	2,255.	2,307.
	1 1/2"	42 5/8"	72"	RTPRS72H5()()	2,003.	2,071.	2,139.	2,207.	2,273.	2,313.	2,366.

Order Code	Specification Information	Application Notes
Example: <b>RTPRS30H5()()</b>	To order please specify pattern number including:	H5 Height: Top of single high overhead to top of 1 1/2" thick desk height work worksurface.
<b>R</b> Reff	1. Trim Finish: Painted or Anodized	*Installation instruction sheets available on-line.
<b>TP</b> Task Panel	2. Top insert finish: Fabric	For Task Panels refer to part number 6TP00085
<b>R</b> Tool rail	3. Bottom insert finish: Fabric	
<b>S</b> Segmented		
<b>30</b> Width		Always supplied including all trim pieces.
<b>H5</b> 42 5/8" high		LH & RH side full height trims. ( no hi-lo trims )
<b>111</b> Trim finish		All trims supplied with the same finish specification.
<b>W281</b> Fabric selection top insert		All Fabric to be applied railroded as current tackboard
<b>W281</b> Fabric selection bottom insert		When ordering 54" or wider Task Panel, please check width of fabric specified.

# Task Panels

*H5 42<sup>5</sup>/<sub>8</sub>" high*

*Segmented With Tool rail*

*Marker board Insert Above / Fabric Insert Below*

description	th	h	w	pattern no.	grade						
					LW10	LW15	LW20	LW30	LW35	LW40	LW45
Task Panel, segmented	1 1/2"	42 5/8"	30"	RTPRS30H5()()	\$1,301.	\$1,316.	\$1,330.	\$1,345.	\$1,385.	\$1,409.	\$1,442.
With tool rail	1 1/2"	42 5/8"	36"	RTPRS36H5()()	1,383.	1,401.	1,419.	1,437.	1,480.	1,506.	1,540.
	1 1/2"	42 5/8"	42"	RTPRS42H5()()	1,576.	1,597.	1,618.	1,639.	1,688.	1,718.	1,757.
	1 1/2"	42 5/8"	48"	RTPRS48H5()()	1,608.	1,631.	1,653.	1,676.	1,726.	1,756.	1,796.
	1 1/2"	42 5/8"	54"	RTPRS54H5()()	1,637.	1,663.	1,689.	1,715.	1,766.	1,797.	1,838.
	1 1/2"	42 5/8"	60"	RTPRS60H5()()	1,673.	1,702.	1,731.	1,760.	1,813.	1,844.	1,886.
	1 1/2"	42 5/8"	66"	RTPRS66H5()()	2,038.	2,069.	2,100.	2,131.	2,195.	2,233.	2,284.
	1 1/2"	42 5/8"	72"	RTPRS72H5()()	2,077.	2,111.	2,145.	2,179.	2,244.	2,283.	2,336.

Order Code	Specification Information	Application Notes
Example: <b>RTPRS30H5()()</b>	To order please specify pattern number including:	H5 Height: Top of single high overhead to top of 1 1/2" thick desk height work surface.
<b>R</b> Reff	1. Trim Finish: Painted or Anodized	*Installation instruction sheets available on-line.
<b>TP</b> Task Panel	2. Top insert finish: Marker board	For Task Panels refer to part number 6TP00085
<b>R</b> Tool rail	3. Bottom insert finish: Fabric	
<b>S</b> Segmentated		
<b>30</b> Width		Always supplied including all trim pieces.
<b>H5</b> 42 5/8" high		LH & RH side full height trims. ( no hi-lo trims )
<b>111</b> Trim finish		All trims supplied with the same finish specification.
<b>LW</b> Marker board top insert		All Fabric to be applied railroaded as current tackboard.
<b>W281</b> Fabric selection bottom insert		When ordering 54" or wider Task Panel, please check width of fabric specified.

# Task Panels

*H5 42<sup>5</sup>/<sub>8</sub>" high*

*Segmented With Tool rail*

*Glass or Fabric Insert Above / Forbo, Laminate or Wood Below*

description	th	h	w	pattern no.	FAB/L	G/FORB	FAB/FORB	FAB/V1	FAB/V2	FAB/V3
Task Panel, segmented	1 1/2"	42 5/8"	30"	RTPRS30H5 ( ) ( )	\$1,306.	\$1,687.	\$1,216.	\$1,349.	\$1,363.	\$1,396.
With tool rail	1 1/2"	42 5/8"	36"	RTPRS36H5 ( ) ( )	1,389.	1,881.	1,308.	1,433.	1,449.	1,489.
	1 1/2"	42 5/8"	42"	RTPRS42H5 ( ) ( )	1,579.	2,180.	1,504.	1,623.	1,642.	1,687.
	1 1/2"	42 5/8"	48"	RTPRS48H5 ( ) ( )	1,601.	2,325.	1,535.	1,680.	1,700.	1,572.
	1 1/2"	42 5/8"	54"	RTPRS54H5 ( ) ( )	1,631.	2,466.	1,574.	1,711.	1,732.	1,789.
	1 1/2"	42 5/8"	60"	RTPRS60H5 ( ) ( )	1,661.	2,607.	1,612.	1,741.	1,765.	1,828.
	1 1/2"	42 5/8"	66"	RTPRS66H5 ( ) ( )	2,034.	3,068.	1,959.	2,114.	2,140.	2,209.
	1 1/2"	42 5/8"	72"	RTPRS72H5 ( ) ( )	2,067.	3,212.	2,001.	2,148.	2,175.	2,251.
	1 1/2"	42 5/8"	78"	RTPRS78H5 ( ) ( )	2,201.	2,458.	2,144.	2,283.	2,312.	2,395.
	1 1/2"	42 5/8"	84"	RTPRS84H5 ( ) ( )	2,221.	3,599.	2,171.	2,304.	2,335.	2,424.
	1 1/2"	42 5/8"	90"	RTPRS90H5 ( ) ( )	2,252.	3,740.	2,210.	2,335.	2,367.	2,463.
	1 1/2"	42 5/8"	96"	RTPRS96H5 ( ) ( )	2,284.	3,883.	2,251.	2,368.	2,402.	2,504.

Order Code	Specification Information	Application Notes
Example: <b>RTPRS30H5 ( ) ( )</b>	To order please specify pattern number including:	H5 Height: Top of single high overhead to top of 1 1/2" thick desk height work worksurface.
<b>R</b> Reff	1. Trim Finish: Painted or Anodized	*Installation instruction sheets available on-line.
<b>TP</b> Task Panel	2. Top insert finish: Glass or Fabric	For Task Panels refer to part number 6TP00085
<b>R</b> Tool rail	3. Bottom insert finish: Forbo, L, V1, V2, V3	Always supplied including cable curtain.
<b>S</b> Segmented		Always supplied including all trim pieces.
<b>30</b> Width		LH & RH side full height trims. ( no hi-lo trims )
<b>H5</b> 42 5/8" high		All trims supplied with the same finish specification.
<b>111</b> Trim finish		All Fabric to be applied railroaded as current tackboard
<b>W281</b> Fabric selection top insert		When ordering 54" or wider Task Panel, please check width of fabric specified.
<b>V319</b> Veneer selection bottom insert		

Task Panels  
*H6 49 1/4" high*  
*Monolithic, Without Tool rail*  
*Fabric*

description	th	h	w	pattern no.	grade						
					10	15	20	30	35	40	45
Task Panel, mono	1 1/2"	49 1/4"	30"	<b>RTPNM30H6( )()</b>	\$917.	\$931.	\$946.	\$960.	\$989.	\$1,006.	\$1,029.
Without tool rail	1 1/2"	49 1/4"	36"	<b>RTPNM36H6( )()</b>	974.	992.	1,009.	1,027.	1,058.	1,076.	1,101.
	1 1/2"	49 1/4"	42"	<b>RTPNM42H6( )()</b>	1,161.	1,182.	1,204.	1,225.	1,262.	1,284.	1,313.
	1 1/2"	49 1/4"	48"	<b>RTPNM48H6( )()</b>	1,178.	1,201.	1,223.	1,246.	1,283.	1,306.	1,336.
	1 1/2"	49 1/4"	54"	<b>RTPNM54H6( )()</b>	1,198.	1,224.	1,250.	1,276.	1,314.	1,337.	1,368.
	1 1/2"	49 1/4"	60"	<b>RTPNM60H6( )()</b>	1,263.	1,292.	1,322.	1,351.	1,392.	1,416.	1,448.
	1 1/2"	49 1/4"	66"	<b>RTPNM66H6( )()</b>	1,495.	1,526.	1,556.	1,587.	1,635.	1,663.	1,701.
	1 1/2"	49 1/4"	72"	<b>RTPNM72H6( )()</b>	1,517.	1,551.	1,585.	1,619.	1,668.	1,697.	1,736.
	1 1/2"	49 1/4"	78"	<b>RTPNM78H6( )()</b>	1,686.	1,723.	1,761.	1,798.	1,852.	1,884.	1,927.
	1 1/2"	49 1/4"	84"	<b>RTPNM84H6( )()</b>	1,700.	1,739.	1,778.	1,817.	1,872.	1,904.	1,948.
	1 1/2"	49 1/4"	90"	<b>RTPNM90H6( )()</b>	1,764.	1,806.	1,849.	1,891.	1,948.	1,982.	2,027.
	1 1/2"	49 1/4"	96"	<b>RTPNM96H6( )()</b>	1,787.	1,832.	1,878.	1,923.	1,981.	2,015.	2,061.

Order Code	Specification Information	Application Notes
Example: <b>RTPNM30H6( )()</b>	To order please specify pattern number including;	H6 Height: Top of single high overhead to top of 1" thick credenza top for 3/4 height cabinet or lower credenza.
<b>R</b> Reff	1. Trim Finish: Painted or Anodized	Always supplied including cable curtain.
<b>TP</b> Task Panel	2. Insert Finish: Fabric	Always supplied including all trim pieces.
<b>N</b> No tool rail		LH & RH side full height trims. ( no hi-lo trims )
<b>M</b> Monolithic		All trims supplied with the same finish specification.
<b>30</b> Width		Tool rails are not supplied to this Task Panel.
<b>H6</b> 49 1/4" high		All Fabric to be applied railroded as current tackboard.
<b>111</b> Trim finish		When ordering 54" or wider Task Panel, please check width of fabric specified.
<b>W281</b> Fabric selection		

\*Installation instruction sheets available on-line.  
 For Task Panels refer to part number 6TP00085



# Task Panels

*H6 49 1/4" high*

*Monolithic, Without Tool rail*

*Wood, Laminate, Marker board or Glass Inserts*

description	th	h	w	pattern no.	glass	LW	L	V1	V2	V3
Task Panel, mono	1 1/2"	49 1/4"	30"	<b>RTPNM30H6( )</b>	\$1,555.	\$966.	\$950.	\$1,059.	\$1,172.	\$1,472.
Without tool rail	1 1/2"	49 1/4"	36"	<b>RTPNM36H6( )</b>	1,762.	1,029.	1,009.	1,122.	1,255.	1,612.
	1 1/2"	49 1/4"	42"	<b>RTPNM42H6( )</b>	2,072.	1,193.	1,215.	1,310.	1,462.	1,878.
	1 1/2"	49 1/4"	48"	<b>RTPNM48H6( )</b>	2,274.	1,244.	1,219.	1,340.	1,506.	1,979.

Order Code	Specification Information	Application Notes
Example: <b>RTPNM30H6( )</b>	To order please specify pattern number including;	H6 Height: Top of single high overhead to top of 1" thick credenza top for 3/4 height cabinet or lower credenza.
<b>R</b> Reff	1. Trim Finish: Painted or Anodized	*Installation instruction sheets available on-line.
<b>TP</b> Task Panel	2. Insert Finish: G, LW, L, V1, V2, V3	For Task Panels refer to part number 6TP00085
<b>N</b> No tool rail		
<b>M</b> Monolithic		Always supplied including cable curtain.
<b>30</b> Width		Always supplied including all trim pieces.
<b>H6</b> 49 1/4" high		LH & RH side full height trims. ( no hi-lo trims )
<b>111</b> Trim finish		All trims supplied with the same finish specification.
<b>V319</b> Veneer selection		Tool rails are not supplied to this Task Panel.
		All Fabric to be applied railroaded as current tackboard.
		When ordering 54" or wider Task Panel, please check width of fabric specified.

**Task Panels**  
*H6 49 1/4" high*  
*Segmented With Tool rail*  
*Fabric Insert Above / Fabric Insert Below*

description	th	h	w	pattern no.	10	15	20	30	35	40	45
Task Panel, segmented	1 1/2"	49 1/4"	30"	<b>RTPRS30H6</b> ( ) ( )	\$1,309.	\$1,338.	\$1,367.	\$1,396.	\$1,429.	\$1,463.	\$1,496.
With tool rail	1 1/2"	49 1/4"	36"	<b>RTPRS36H6</b> ( ) ( )	1,395.	1,431.	1,466.	1,502.	1,538.	1,574.	1,610.
	1 1/2"	49 1/4"	42"	<b>RTPRS42H6</b> ( ) ( )	1,587.	1,629.	1,671.	1,713.	1,754.	1,795.	1,836.
	1 1/2"	49 1/4"	48"	<b>RTPRS48H6</b> ( ) ( )	1,611.	1,656.	1,702.	1,747.	1,879.	1,831.	1,873.
	1 1/2"	49 1/4"	54"	<b>RTPRS54H6</b> ( ) ( )	1,644.	1,696.	1,748.	1,800.	1,843.	1,886.	1,929.
	1 1/2"	49 1/4"	60"	<b>RTPRS60H6</b> ( ) ( )	1,678.	1,736.	1,795.	1,853.	1,897.	1,942.	1,986.
	1 1/2"	49 1/4"	66"	<b>RTPRS66H6</b> ( ) ( )	2,018.	2,080.	2,141.	2,203.	2,256.	2,309.	2,361.
	1 1/2"	49 1/4"	72"	<b>RTPRS72H6</b> ( ) ( )	2,054.	2,122.	2,191.	2,259.	2,327.	2,367.	2,421.

Order Code	Specification Information	Application Notes
Example: <b>RTPRS30H6</b> ( ) ( )	To order please specify pattern number including;	H6 Height: Top of single high overhead to top of 1" thick credenza top for 3/4 height cabinet or lower credenza.
<b>R</b> Reff	1. Trim Finish: Painted or Anodized	*Installation instruction sheets available on-line.
<b>TP</b> Task Panel	2. Top insert finish: Fabric	For Task Panels refer to part number 6TP00085
<b>N</b> No tool rail	3. Bottom insert finish: Fabric	
<b>S</b> Segmented		Always supplied including cable curtain.
<b>30</b> Width		Always supplied including all trim pieces.
<b>H6</b> 49 1/4" high		LH & RH side full height trims. ( no hi-lo trims )
<b>111</b> Trim finish		All trims supplied with the same finish specification.
<b>W281</b> Fabric selection top		All Fabric to be applied railroded as current tackboard.
<b>W281</b> Fabric selection bottom		When ordering 54" or wider Task Panel, please check width of fabric specified.

**Task Panels**  
*H6 49 1/4" high*  
*Segmented With Tool rail*  
*Marker board Insert Above / Fabric Insert Below*

description	th	h	w	pattern no.	LW10	LW15	LW20	LW30	LW35	LW40	LW45
Task Panel, segmented	1 1/2"	49 1/4"	30"	<b>RTPRS30H6</b> ( ) ( )	\$1,347.	\$1,361.	\$1,376.	\$1,390.	\$1,432.	\$1,457.	\$1,490.
With tool rail	1 1/2"	49 1/4"	36"	<b>RTPRS36H6</b> ( ) ( )	1,430.	1,448.	1,465.	1,483.	1,527.	1,554.	1,590.
	1 1/2"	49 1/4"	42"	<b>RTPRS42H6</b> ( ) ( )	1,623.	1,644.	1,665.	1,686.	1,736.	1,767.	1,807.
	1 1/2"	49 1/4"	48"	<b>RTPRS48H6</b> ( ) ( )	1,657.	1,680.	1,702.	1,725.	1,777.	1,808.	1,849.
	1 1/2"	49 1/4"	54"	<b>RTPRS54H6</b> ( ) ( )	1,686.	1,712.	1,738.	1,764.	1,817.	1,849.	1,891.
	1 1/2"	49 1/4"	60"	<b>RTPRS60H6</b> ( ) ( )	1,723.	1,752.	1,782.	1,811.	1,865.	1,898.	1,941.
	1 1/2"	49 1/4"	66"	<b>RTPRS66H6</b> ( ) ( )	2,089.	2,120.	2,151.	2,182.	2,247.	2,287.	2,339.

Accessories and Client Samples

Order Code	Specification Information	Application Notes
Example: <b>RTPRS30H6</b> ( ) ( )	To order please specify pattern number including;	H6 Height: Top of single high overhead to top of 1" thick credenza top for 3/4 height cabinet or lower credenza.
<b>R</b> Reff	1. Trim Finish: Painted or Anodized	*Installation instruction sheets available on-line.
<b>TP</b> Task Panel	2. Top insert finish: Marker board	For Task Panels refer to part number 6TP00085
<b>R</b> Tool rail	3. Bottom insert finish: Fabric	
<b>S</b> Segmentated		Always supplied including cable curtain.
<b>30</b> Width		Always supplied including all trim pieces.
<b>H6</b> 49 1/4" high		LH & RH side full height trims. ( no hi-lo trims )
<b>111</b> Trim finish		All trims supplied with the same finish specification.
<b>LW</b> Marker board top insert		All Fabric to be applied railroaded as current tackboard.
<b>W281</b> Fabric selection bottom insert		When ordering 54" or wider Task Panel, please check width of fabric specified.

# Task Panels

*H6 49 1/4" high*

*Segmented With Tool rail*

*Glass or Fabric Insert Above / Forbo, Laminate or Wood Below*

description	th	h	w	pattern no.	G/FORB	FAB/FORB	FAB/L	FAB/V1	FAB/V2	FAB/V3
Task Panel, segmented	1 1/2"	49 1/4"	30"	<b>RTPRS30H6( ) ( )</b>	\$1,818.	\$1,347.	\$1,343.	\$1,408.	\$1,446.	\$1,519.
With tool rail	1 1/2"	49 1/4"	36"	<b>RTPRS36H6( ) ( )</b>	2,031.	1,457.	1,428.	1,494.	1,538.	1,626.
	1 1/2"	49 1/4"	42"	<b>RTPRS42H6( ) ( )</b>	2,348.	1,672.	1,623.	1,691.	1,738.	1,839.
	1 1/2"	49 1/4"	48"	<b>RTPRS48H6( ) ( )</b>	2,510.	1,720.	1,647.	1,744.	1,796.	1,913.
	1 1/2"	49 1/4"	54"	<b>RTPRS54H6( ) ( )</b>	2,670.	1,777.	1,680.	1,777.	1,834.	1,964.
	1 1/2"	49 1/4"	60"	<b>RTPRS60H6( ) ( )</b>	2,829.	1,834.	1,712.	1,811.	1,872.	2,015.
	1 1/2"	49 1/4"	66"	<b>RTPRS66H6( ) ( )</b>	3,308.	2,199.	2,078.	2,177.	2,243.	2,402.
	1 1/2"	49 1/4"	72"	<b>RTPRS72H6( ) ( )</b>	3,470.	2,259.	2,112.	2,214.	2,283.	2,456.
	1 1/2"	49 1/4"	78"	<b>RTPRS78H6( ) ( )</b>	3,734.	2,420.	2,254.	2,356.	2,425.	2,611.
	1 1/2"	49 1/4"	84"	<b>RTPRS84H6( ) ( )</b>	3,893.	2,466.	2,278.	2,381.	2,456.	2,657.
	1 1/2"	49 1/4"	90"	<b>RTPRS90H6( ) ( )</b>	4,053.	2,522.	2,311.	2,415.	2,493.	2,708.
	1 1/2"	49 1/4"	96"	<b>RTPRS96H6( ) ( )</b>	4,214.	2,581.	2,345.	2,451.	2,533.	2,762.

Order Code	Specification Information	Application Notes
Example: <b>RTPRS30H6( ) ( )</b>	To order please specify pattern number including;	H6 Height: Top of single high overhead to top of 1" thick credenza top for 3/4 height cabinet or lower credenza.
<b>R</b> Reff	1. Trim Finish: Painted or Anodized	*Installation instruction sheets available on-line.
<b>TP</b> Task Panel	2. Top insert finish: Glass or Fabric	For Task Panels refer to part number 6TP00085
<b>R</b> Tool rail	3. Bottom insert finish: Forbo, L, V1, V2, V3	Always supplied including cable curtain.
<b>S</b> Segmentated		Always supplied including all trim pieces.
<b>30</b> Width		LH & RH side full height trims. ( no hi-lo trims )
<b>H6</b> 49 1/4" high		All trims supplied with the same finish specification.
<b>111</b> Trim finish		All Fabric to be applied railroaded as current tackboard.
<b>W281</b> Fabric selection top insert		When ordering 54" or wider Task Panel, please check width of fabric specified.
<b>V319</b> Veneer selection bottom insert		

# Task Panels

*H7 56 1/8" high*

*Monolithic, Without Tool rail*

*Wood, Laminate, Marker board or Glass Inserts*

description	th	h	w	pattern n	glass	LW10	L	V1	V2	V3
Task Panel, mono	1 1/2"	56 1/8"	30"	<b>RTPNM30H7</b> (X)	\$1,683.	\$982.	\$964.	\$1,067.	\$1,203.	\$1,557.
Without tool rail	1 1/2"	56 1/8"	36"	<b>RTPNM36H7</b> (X)	1,916.	1,047.	1,025.	1,142.	1,291.	1,711.
	1 1/2"	56 1/8"	42"	<b>RTPNM42H7</b> (X)	2,247.	1,244.	1,219.	1,340.	1,518.	2,006.
	1 1/2"	56 1/8"	48"	<b>RTPNM48H7</b> (X)	2,479.	1,275.	1,247.	1,373.	1,566.	2,122.

Order Code	Specification Information	Application Notes
Example: <b>RTPNM30H7</b> (X)	To order please specify pattern number including;	H7 Height: Top of double high overhead to top of 1 1/2" thick desk height worksurface.
<b>R</b> Reff		*Installation instruction sheets available on-line.
<b>TP</b> Task Panel	1. Trim Finish: Painted or Anodized	For Task Panels refer to part number 6TP00085
<b>N</b> No tool rail	2. Insert Finish: Veneer	
<b>M</b> Monolithic		Always supplied including cable curtain.
<b>30</b> Width		Always supplied including all trim pieces.
<b>H7</b> 56 1/8" high		LH & RH side full height trims. ( no hi-lo trims )
<b>111</b> Trim finish		All trims supplied with the same finish specification.
<b>V319</b> Veneer selection		Tool rails are not supplied to this Task Panel.
		All Fabric to be applied railroaded as current tackboard
		When ordering 54" or wider Task Panel, please check width of fabric specified.

Task Panels  
*H7 56 1/8" high*  
*Segmented With Tool rail*  
*Fabric Insert Above / Fabric Insert Below*

description	th	h	w	pattern no.	grade						
					10	15	20	30	35	40	45
Task Panel, segmented	1 1/2"	56 1/8"	30"	RTPRS30H7()()	\$1,315.	\$1,344.	\$1,373.	\$1,402.	\$1,436.	\$1,469.	\$1,503.
With tool rail	1 1/2"	56 1/8"	36"	RTPRS36H7()()	1,403.	1,439.	1,474.	1,510.	1,546.	1,582.	1,619.
	1 1/2"	56 1/8"	42"	RTPRS42H7()()	1,595.	1,637.	1,680.	1,722.	1,763.	1,805.	1,846.
	1 1/2"	56 1/8"	48"	RTPRS48H7()()	1,620.	1,665.	1,711.	1,756.	1,798.	1,840.	1,882.
	1 1/2"	56 1/8"	54"	RTPRS54H7()()	1,655.	1,707.	1,758.	1,810.	1,853.	1,897.	1,940.
	1 1/2"	56 1/8"	60"	RTPRS60H7()()	1,689.	1,747.	1,806.	1,864.	1,909.	1,953.	1,998.

Order Code	Specification Information	Application Notes	
Example: <b>RTPRS30H7()()</b>	To order please specify pattern number including: 1. Trim Finish: Painted or Anodized 2. Top insert finish: Fabric 3. Bottom insert finish: Fabric	H7 Height: Top of double high overhead to top of 1 1/2" thick desk height worksurface.  Always supplied including cable curtain.  Always supplied including all trim pieces.  LH & RH side full height trims. ( no hi-lo trims )  All trims supplied with the same finish specification.  All Fabric to be applied railroaded as current tackboard  When ordering 54" or wider Task Panel, please check width of fabric specified.	
<b>R</b> Reff			*Installation instruction sheets available on-line.
<b>TP</b> Task Panel			For Task Panels refer to part number 6TP00085
<b>R</b> Tool rail			
<b>S</b> Segmented			
<b>30</b> Width			
<b>H7</b> 56 1/8" high			
<b>111</b> Trim finish			
<b>W281</b> Fabric selection top			
<b>W281</b> Fabric selection bottom			

**Task Panels**  
*H7 56 1/8" high*  
*Segmented With Tool rail*  
*Marker board Insert Above / Fabric Insert Below*

description	th	h	w	pattern no.	LW10	LW15	LW20	LW30	LW35	LW40	LW45
Task Panel, segmented	1 1/2"	56 1/8"	30"	<b>RTPRS30H7()</b> ( ) ( )	\$1,378.	\$1,393.	\$1,407.	\$1,422.	\$1,456.	\$1,490.	\$1,524.
With tool rail	1 1/2"	56 1/8"	36"	<b>RTPRS36H7()</b> ( ) ( )	1,472.	1,490.	1,507.	1,525.	1,562.	1,598.	1,635.
	1 1/2"	56 1/8"	42"	<b>RTPRS42H7()</b> ( ) ( )	1,670.	1,691.	1,713.	1,734.	1,776.	1,817.	1,859.
	1 1/2"	56 1/8"	48"	<b>RTPRS48H7()</b> ( ) ( )	1,701.	1,724.	1,746.	1,769.	1,811.	1,854.	1,896.

Accessories and Client Samples

Order Code	Specification Information	Application Notes
Example: <b>RTPRS30H7()</b> ( ) ( )	To order please specify pattern number including:	H7 Height: Top of double high overhead to top of 1 1/2" thick desk height worksurface.
<b>R</b> Reff	1. Trim Finish: Painted or Anodized	*Installation instruction sheets available on-line.
<b>TP</b> Task Panel	2. Top insert finish: Marker board	For Task Panels refer to part number 6TP00085
<b>R</b> Tool rail	3. Bottom insert finish: Fabric	
<b>S</b> Segmented		Always supplied including cable curtain.
<b>30</b> Width		Always supplied including all trim pieces.
<b>H7</b> 56 1/8" high		LH & RH side full height trims. ( no hi-lo trims )
<b>111</b> Trim finish		All trims supplied with the same finish specification.
<b>LW</b> Marker board top insert		All Fabric to be applied railroaded as current tackboard
<b>W281</b> Fabric selection bottom insert		When ordering 54" or wider Task Panel, please check width of fabric specified.

# Task Panels

*H7 56 1/8" high*

*Segmented With Tool rail*

*Glass or Fabric Insert Above / Forbo, Laminate or Wood Below*

description	th	h	w	pattern no.	G/FORB	FAB/FORB	FAB/L	FAB/V1	FAB/V2	FAB/V3
Task Panel, segmented	1 1/2"	56 1/8"	30"	<b>RTPRS30H7</b> ( ) ( )	\$1,965.	\$1,267.	\$1,357.	\$1,400.	\$1,415.	\$1,448.
With tool rail	1 1/2"	56 1/8"	36"	<b>RTPRS36H7</b> ( ) ( )	2,207.	1,361.	1,443.	1,486.	1,503.	1,542.
	1 1/2"	56 1/8"	42"	<b>RTPRS42H7</b> ( ) ( )	2,553.	1,560.	1,695.	1,679.	1,697.	1,743.
	1 1/2"	56 1/8"	48"	<b>RTPRS48H7</b> ( ) ( )	2,745.	1,592.	1,658.	1,738.	1,758.	1,810.
	1 1/2"	56 1/8"	54"	<b>RTPRS54H7</b> ( ) ( )	n/a	n/a	1,691.	1,770.	1,792.	1,849.
	1 1/2"	56 1/8"	60"	<b>RTPRS60H7</b> ( ) ( )	n/a	n/a	1,723.	1,803.	1,826.	1,890.

Order Code	Specification Information	Application Notes
Example: <b>RTPRS30H7</b> ( ) ( )	To order please specify pattern number including:	H7 Height: Top of double high overhead to top of 1 1/2" thick desk height worksurface.
<b>R</b> Reff	1. Trim Finish: Painted or Anodized	*Installation instruction sheets available on-line.
<b>TP</b> Task Panel	2. Top insert finish: Glass or Fabric	For Task Panels refer to part number 6TP00085
<b>R</b> Tool rail	3. Bottom insert finish: Forbo, L, V1, V2, V3	Always supplied including cable curtain.
<b>S</b> Segmented		Always supplied including all trim pieces.
<b>30</b> Width		LH & RH side full height trims. ( no hi-lo trims )
<b>H7</b> 56 1/8" high		All trims supplied with the same finish specification.
<b>111</b> Trim finish		All Fabric to be applied railroaded as current tackboard
<b>W281</b> Fabric selection top insert		When ordering 54" or wider Task Panel, please check width of fabric specified.
<b>V319</b> Veneer selection bottom insert		



# Task Panels

*H8 62<sup>3</sup>/<sub>4</sub>" high*

*Monolithic, Without Tool rail*

*Wood, Laminate, Marker board or Glass Inserts*

description	th	h	w	pattern no.	glass	LW	L	V1	V2	V3
Task Panel, mono	1 1/2"	62 3/4"	30"	<b>RTPNM30H8()</b> ( )	\$1,969.	\$1,184.	\$1,164.	\$1,279.	\$1,420.	\$1,804.
Without tool rail	1 1/2"	62 3/4"	36"	<b>RTPNM36H8()</b> ( )	2,227.	1,253.	1,229.	1,348.	1,509.	1,966.
	1 1/2"	62 3/4"	42"	<b>RTPNM42H8()</b> ( )	2,579.	1,452.	1,424.	1,549.	1,739.	2,270.
	1 1/2"	62 3/4"	48"	<b>RTPNM48H8()</b> ( )	2,841.	1,479.	1,447.	1,578.	1,793.	2,399.

Order Code	Specification Information	Application Notes
Example: <b>RTPNM30H8()</b> ( )	To order please specify pattern number including;	H8 Height: Top of double high overhead to top of 1" thick credenza top for 3/4 height cabinet.
<b>R</b> Reff	1. Trim Finish: Painted or Anodized	*Installation instruction sheets available on-line.
<b>TP</b> Task Panel	2. Insert Finish: G, LW, L, V1, V2, V3	For Task Panels refer to part number 6TP00085
<b>N</b> No tool rail		
<b>M</b> Monolithic		
<b>30</b> Width		Always supplied including all trim pieces.
<b>H8</b> 62 <sup>3</sup> / <sub>4</sub> " high		LH & RH side full height trims. ( no hi-lo trims )
<b>111</b> Trim finish		All trims supplied with the same finish specification.
<b>V319</b> Veneer selection		Tool rails are not supplied to this Task Panel.
		All Fabric to be applied railroaded as current tackboard
		When ordering 54" or wider Task Panel, please check width of fabric specified.

Task Panels  
*H8 62<sup>3</sup>/<sub>4</sub>" high*  
*Segmented With Tool rail*  
*Fabric Insert Above / Fabric Insert Below*

description	th	h	w	pattern no.	grade						
					10	15	20	30	35	40	45
Task Panel, segmented	1 1/2"	62 3/4"	30"	RTPRS30H8()()	\$1,478.	\$1,507.	\$1,537.	\$1,566.	\$1,613.	\$1,641.	\$1,679.
With tool rail	1 1/2"	62 3/4"	36"	RTPRS36H8()()	1,567.	1,603.	1,638.	1,674.	1,724.	1,754.	1,795.
	1 1/2"	62 3/4"	42"	RTPRS42H8()()	1,760.	1,802.	1,845.	1,887.	1,944.	1,978.	2,023.
	1 1/2"	62 3/4"	48"	RTPRS48H8()()	1,786.	1,831.	1,877.	1,922.	1,980.	2,014.	2,060.
	1 1/2"	62 3/4"	54"	RTPRS54H8()()	1,822.	1,874.	1,925.	1,977.	2,036.	2,072.	2,119.
	1 1/2"	62 3/4"	60"	RTPRS60H8()()	1,857.	1,915.	1,974.	2,032.	2,093.	2,130.	2,178.
	1 1/2"	62 3/4"	66"	RTPRS66H8()()	2,200.	2,262.	2,323.	2,385.	2,457.	2,499.	2,557.
	1 1/2"	62 3/4"	72"	RTPRS72H8()()	2,240.	3,202.	2,363.	2,425.	2,498.	2,541.	2,600.

Order Code	Specification Information	Application Notes
Example: <b>RTPRS30H8()()</b>	To order please specify pattern number including:	H8 Height: Top of double high overhead to top of 1" thick credenza top for 3/4 height cabinet.
<b>R</b> Reff	1. Trim Finish: Painted or Anodized	*Installation instruction sheets available on-line.
<b>TP</b> Task Panel	2. Top insert finish: Fabric	For Task Panels refer to part number 6TP00085
<b>N</b> No tool rail	3. Bottom insert finish: Fabric	
<b>M</b> Monolithic		
<b>30</b> Width		Always supplied including cable curtain.
<b>H8</b> 62 <sup>3</sup> / <sub>4</sub> " high		Always supplied including all trim pieces.
<b>111</b> Trim finish		LH & RH side full height trims. ( no hi-lo trims )
<b>W281</b> Fabric selection top		All trims supplied with the same finish specification.
<b>W281</b> Fabric selection bottom		All Fabric to be applied railroaded as current tackboard
		When ordering 54" or wider Task Panel, please check width of fabric specified.

Task Panels  
*H8 62<sup>3</sup>/<sub>4</sub>" high*  
*Segmented With Tool rail*  
*Marker board Insert Above / Fabric Insert Below*

description	th	h	w	pattern no.	LW10	LW15	LW20	LW30	LW35	LW40	LW45
Task Panel, segmented	1 1/2"	62 3/4"	30"	<b>RTPRS30H8</b> ( ) ( )	\$1,541.	\$1,556.	\$1,570.	\$1,585.	\$1,623.	\$1,661.	\$1,699.
With tool rail	1 1/2"	62 3/4"	36"	<b>RTPRS36H8</b> ( ) ( )	1,636.	1,654.	1,671.	1,689.	1,730.	1,770.	1,811.
	1 1/2"	62 3/4"	42"	<b>RTPRS42H8</b> ( ) ( )	1,836.	1,857.	1,878.	1,899.	1,945.	1,990.	2,036.
	1 1/2"	62 3/4"	48"	<b>RTPRS48H8</b> ( ) ( )	1,867.	1,890.	1,912.	1,935.	1,981.	2,028.	2,074.

Order Code	Specification Information	Application Notes
Example: <b>RTPRS30H8</b> ( ) ( )	To order please specify pattern number including:	H8 Height: Top of double high overhead to top of 1" thick credenza top for 3/4 height cabinet.
<b>R</b> Reff	1. Trim Finish: Painted or Anodized	*Installation instruction sheets available on-line.
<b>TP</b> Task Panel	2. Top insert finish: Marker board	For Task Panels refer to part number 6TP00085
<b>R</b> Tool rail	3. Bottom insert finish: Fabric	
<b>S</b> Segmented		
<b>30</b> Width		Always supplied including cable curtain.
<b>H8</b> 62 3/4" high		Always supplied including all trim pieces.
<b>111</b> Trim finish		LH & RH side full height trims. ( no hi-lo trims )
<b>LW</b> Marker board top insert		All trims supplied with the same finish specification.
<b>W281</b> Fabric selection bottom insert		All Fabric to be applied railroaded as current tackboard
		When ordering 54" or wider Task Panel, please check width of fabric specified.

# Task Panels

*H8 62<sup>3</sup>/<sub>4</sub>" high*

*Segmented With Tool rail*

*Glass or Fabric Insert Above / Forbo, Laminate or Wood Below*

description	th	h	w	pattern no.	G/FORB	FAB/FORB	FAB/L	FAB/V1	FAB/V2	FAB/V3
Task Panel, segmented	1 1/2"	62 3/4"	30"	<b>RTPRS30H8</b> ( ) ( )	\$2,214.	\$1,517.	\$1,512.	\$1,578.	\$1,616.	\$1,688.
With tool rail	1 1/2"	62 3/4"	36"	<b>RTPRS36H8</b> ( ) ( )	2,474.	1,628.	1,600.	1,666.	1,709.	1,797.
	1 1/2"	62 3/4"	42"	<b>RTPRS42H8</b> ( ) ( )	2,838.	1,845.	1,797.	1,864.	1,911.	2,013.
	1 1/2"	62 3/4"	48"	<b>RTPRS48H8</b> ( ) ( )	3,048.	1,896.	1,823.	1,919.	1,972.	2,088.
	1 1/2"	62 3/4"	54"	<b>RTPRS54H8</b> ( ) ( )	3,255.	1,955.	1,885.	1,955.	2,012.	2,142.
	1 1/2"	62 3/4"	60"	<b>RTPRS60H8</b> ( ) ( )	3,461.	2,013.	1,892.	1,990.	2,051.	2,195.

Order Code	Specification Information	Application Notes
Example: <b>RTPRS30H8</b> ( ) ( )	To order please specify pattern number including:	H8 Height: Top of double high overhead to top of 1" thick credenza top for 3/4 height cabinet.
<b>R</b> Reff	1. Trim Finish: Painted or Anodized	*Installation instruction sheets available on-line.
<b>TP</b> Task Panel	2. Top insert finish: Glass or Fabric	For Task Panels refer to part number 6TP00085
<b>R</b> Tool rail	3. Bottom insert finish: Forbo, L, V1, V2, V3	Always supplied including cable curtain.
<b>S</b> Segmented		Always supplied including all trim pieces.
<b>30</b> Width		LH & RH side full height trims. ( no hi-lo trims )
<b>H8</b> 62 3/4" high		All trims supplied with the same finish specification.
<b>111</b> Trim finish		All Fabric to be applied railroaded as current tackboard
<b>W281</b> Fabric selection top insert		When ordering 54" or wider Task Panel, please check width of fabric specified.
<b>V319</b> Veneer selection bottom insert		

Tackboards  
*H1 23 1/8" high*  
*Wall hung, fabric*

description	th	h	w	pattern no.	grade						
					10	15	20	30	35	40	45
Tackboard, wall hung	1 1/2"	23 1/8"	30"	<b>RWHDHTB30H1()</b>	\$254.	\$279.	\$305.	\$330.	\$335.	\$340.	\$345.
	1 1/2"	23 1/8"	36"	<b>RWHDHTB36H1()</b>	271.	299.	326.	354.	360.	365.	371.
	1 1/2"	23 1/8"	42"	<b>RWHDHTB42H1()</b>	298.	331.	363.	396.	403.	409.	416.
	1 1/2"	23 1/8"	48"	<b>RWHDHTB48H1()</b>	324.	362.	399.	437.	445.	452.	460.
	1 1/2"	23 1/8"	54"	<b>RWHDHTB54H1()</b>	342.	382.	422.	462.	470.	479.	787.
	1 1/2"	23 1/8"	60"	<b>RWHDHTB60H1()</b>	368.	413.	459.	504.	513.	522.	531.
	1 1/2"	23 1/8"	66"	<b>RWHDHTB66H1()</b>	386.	434.	481.	529.	539.	548.	558.
	1 1/2"	23 1/8"	72"	<b>RWHDHTB72H1()</b>	413.	466.	518.	571.	582.	592.	603.
	1 1/2"	23 1/8"	78"	<b>RWHDHTB78H1()</b>	439.	497.	554.	612.	624.	635.	647.
	1 1/2"	23 1/8"	84"	<b>RWHDHTB84H1()</b>	466.	529.	591.	654.	667.	679.	692.
	1 1/2"	23 1/8"	90"	<b>RWHDHTB90H1()</b>	483.	548.	613.	678.	691.	705.	718.
	1 1/2"	23 1/8"	96"	<b>RWHDHTB96H1()</b>	510.	580.	651.	721.	735.	749.	763.

**Order Code**

Example: <b>RWHDHTB30H1()</b>
<b>R</b> Reff
<b>WH</b> Wall hung
<b>DH</b> Desk height planning
<b>TB</b> Tackboard
<b>30</b> Width
<b>H1</b> 23 1/8" high
<b>W281</b> Fabric selection

**Specification Information**

To order please specify pattern number including;  
 1. Finish: Fabric

**Application Notes**

H1 Height: Underside of overhead to top 1 1/2" thick desk height worksurface.

Tackboards  
*H2 29<sup>3</sup>/<sub>4</sub>" high*  
*Wall hung, fabric*

description	th	h	w	pattern no.	grade						
					10	15	20	30	35	40	45
Tackboard , wall hung	1 1/2"	29 3/4"	30"	<b>RWHDHTB30H2( )</b>	\$269.	\$293.	\$317.	\$341.	\$346.	\$351.	\$356.
	1 1/2"	29 3/4"	36"	<b>RWHDHTB36H2( )</b>	289.	316.	342.	369.	375.	380.	386.
	1 1/2"	29 3/4"	42"	<b>RWHDHTB42H2( )</b>	318.	350.	381.	413.	419.	426.	432.
	1 1/2"	29 3/4"	48"	<b>RWHDHTB48H2( )</b>	348.	384.	420.	456.	464.	471.	479.
	1 1/2"	29 3/4"	54"	<b>RWHDHTB54H2( )</b>	368.	407.	445.	484.	492.	500.	508.
	1 1/2"	29 3/4"	60"	<b>RWHDHTB60H2( )</b>	397.	441.	484.	528.	537.	546.	555.
	1 1/2"	29 3/4"	66"	<b>RWHDHTB66H2( )</b>	417.	463.	509.	555.	565.	574.	584.
	1 1/2"	29 3/4"	72"	<b>RWHDHTB72H2( )</b>	447.	498.	548.	599.	610.	620.	631.
	1 1/2"	29 3/4"	78"	<b>RWHDHTB78H2( )</b>	476.	532.	587.	643.	655.	666.	678.
	1 1/2"	29 3/4"	84"	<b>RWHDHTB84H2( )</b>	505.	566.	626.	687.	700.	712.	725.
	1 1/2"	29 3/4"	90"	<b>RWHDHTB90H2( )</b>	526.	589.	651.	714.	727.	741.	754.
	1 1/2"	29 3/4"	96"	<b>RWHDHTB96H2( )</b>	555.	623.	690.	758.	772.	787.	801.

**Order Code**

Example:	<b>RWHDHTB30H2 ( )</b>
<b>R</b>	Reff
<b>WH</b>	Wall hung
<b>DH</b>	Desk height planning
<b>TB</b>	Tackboard
<b>30</b>	Width
<b>H2</b>	29 3/4" high
<b>W281</b>	Fabric selection

**Specification Information**

To order please specify pattern number including;  
 1. Finish: Fabric

**Application Notes**

H2 Height = Underside of overhead to top of 1" thick credenza top for 3/4 height cabinets.

Tackboards  
*H3 37<sup>7</sup>/<sub>8</sub>" high*  
*Wall hung, fabric*

Reff Profiles

description	th	h	w	pattern no.	grade						
					10	15	20	30	35	40	45
Tackboard , wall hung	1 1/2"	37 7/8"	30"	<b>RWHDHTB30H3( )</b>	\$283.	\$307.	\$332.	\$356.	\$361.	\$366.	\$371.
	1 1/2"	37 7/8"	36"	<b>RWHDHTB36H3( )</b>	306.	333.	359.	386.	392.	397.	403.
	1 1/2"	37 7/8"	42"	<b>RWHDHTB42H3( )</b>	338.	369.	401.	432.	439.	445.	452.
	1 1/2"	37 7/8"	48"	<b>RWHDHTB48H3( )</b>	371.	407.	443.	479.	487.	494.	502.
	1 1/2"	37 7/8"	54"	<b>RWHDHTB54H3( )</b>	393.	432.	470.	509.	517.	526.	534.
	1 1/2"	37 7/8"	60"	<b>RWHDHTB60H3( )</b>	426.	469.	513.	556.	565.	575.	584.
	1 1/2"	37 7/8"	66"	<b>RWHDHTB66H3( )</b>	448.	494.	540.	586.	596.	605.	615.
	1 1/2"	37 7/8"	72"	<b>RWHDHTB72H3( )</b>	481.	532.	582.	633.	644.	654.	665.
	1 1/2"	37 7/8"	78"	<b>RWHDHTB78H3( )</b>	513.	569.	624.	680.	692.	703.	715.
	1 1/2"	37 7/8"	84"	<b>RWHDHTB84H3( )</b>	546.	606.	667.	727.	740.	752.	765.
	1 1/2"	37 7/8"	90"	<b>RWHDHTB90H3( )</b>	568.	631.	693.	756.	769.	783.	796.
	1 1/2"	37 7/8"	96"	<b>RWHDHTB96H3( )</b>	601.	668.	736.	803.	817.	832.	846.

Accessories and Client  
Samples

**Order Code**

Example: <b>RWHDHTB30H3( )</b>
<b>R</b> Reff
<b>WH</b> Wall hung
<b>DH</b> Desk height planning
<b>TB</b> Tackboard
<b>30</b> Width
<b>H3</b> 37 7/8" high
<b>W281</b> Fabric selection

**Specification Information**

To order please specify pattern number including;  
 1. Finish: Fabric

**Application Notes**

H3 Height = Top of U-shelf or L-shelf overhead to top of 1 1/2" thick desk height worksurface.

Tackboards  
*H4 44 1/2" high*  
*Wall hung, fabric*

description	th	h	w	pattern no.	grade						
					10	15	20	30	35	40	45
Tackboard , wall hung	1 1/2"	44 1/2"	30"	<b>RWHDHTB30H4( )</b>	\$295.	\$319.	\$344.	\$368.	\$373.	\$378.	\$383.
	1 1/2"	44 1/2"	36"	<b>RWHDHTB36H4( )</b>	320.	347.	373.	400.	406.	411.	417.
	1 1/2"	44 1/2"	42"	<b>RWHDHTB42H4( )</b>	355.	386.	418.	449.	456.	462.	469.
	1 1/2"	44 1/2"	48"	<b>RWHDHTB48H4( )</b>	389.	425.	462.	498.	506.	513.	521.
	1 1/2"	44 1/2"	54"	<b>RWHDHTB54H4( )</b>	415.	454.	492.	531.	539.	547.	555.
	1 1/2"	44 1/2"	60"	<b>RWHDHTB60H4( )</b>	449.	492.	536.	579.	588.	598.	607.
	1 1/2"	44 1/2"	66"	<b>RWHDHTB66H4( )</b>	474.	520.	566.	612.	622.	631.	641.
	1 1/2"	44 1/2"	72"	<b>RWHDHTB72H4( )</b>	509.	560.	610.	661.	672.	682.	693.
	1 1/2"	44 1/2"	78"	<b>RWHDHTB78H4( )</b>	544.	599.	655.	710.	722.	734.	746.
	1 1/2"	44 1/2"	84"	<b>RWHDHTB84H4( )</b>	578.	638.	699.	759.	772.	784.	797.
	1 1/2"	44 1/2"	90"	<b>RWHDHTB90H4( )</b>	603.	666.	729.	792.	805.	819.	832.
	1 1/2"	44 1/2"	96"	<b>RWHDHTB96H4( )</b>	637.	705.	772.	840.	854.	869.	883.

**Order Code**

Example: <b>RWHDHTB30H4( )</b>
<b>R</b> Reff
<b>WH</b> Wall hung
<b>DH</b> Desk height planning
<b>TB</b> Tackboard
<b>30</b> Width
<b>H4</b> 44 1/2" high
<b>W281</b> Fabric selection

**Specification Information**

To order please specify pattern number including;  
 1. Finish: Fabric

**Application Notes**

H4 Height = Top of U-shelf or L-shelf overhead to top of 1" thick credenza top for 3/4" height cabinet.



Tackboards  
*H5 42<sup>5</sup>/<sub>8</sub>" high*  
*Wall hung, fabric*

Reff Profiles

description	th	h	w	pattern no.	grade						
					10	15	20	30	35	40	45
Tackboard , wall hung	1 1/2"	42 5/8"	30"	<b>RWHDHTB30H5( )</b>	\$292.	\$316.	\$340.	\$364.	\$369.	\$375.	\$380.
	1 1/2"	42 5/8"	36"	<b>RWHDHTB36H5( )</b>	317.	343.	370.	396.	402.	407.	413.
	1 1/2"	42 5/8"	42"	<b>RWHDHTB42H5( )</b>	350.	381.	413.	444.	451.	457.	464.
	1 1/2"	42 5/8"	48"	<b>RWHDHTB48H5( )</b>	384.	420.	457.	493.	501.	508.	516.
	1 1/2"	42 5/8"	54"	<b>RWHDHTB54H5( )</b>	409.	448.	486.	525.	533.	541.	549.
	1 1/2"	42 5/8"	60"	<b>RWHDHTB60H5( )</b>	442.	486.	529.	573.	582.	591.	600.
	1 1/2"	42 5/8"	66"	<b>RWHDHTB66H5( )</b>	467.	513.	558.	604.	614.	624.	634.
	1 1/2"	42 5/8"	72"	<b>RWHDHTB72H5( )</b>	501.	552.	602.	653.	664.	674.	685.
	1 1/2"	42 5/8"	78"	<b>RWHDHTB78H5( )</b>	535.	590.	646.	701.	713.	724.	736.
	1 1/2"	42 5/8"	84"	<b>RWHDHTB84H5( )</b>	569.	639.	690.	750.	763.	775.	788.
	1 1/2"	42 5/8"	90"	<b>RWHDHTB90H5( )</b>	593.	656.	719.	782.	795.	808.	821.
	1 1/2"	42 5/8"	96"	<b>RWHDHTB96H5( )</b>	628.	695.	763.	830.	844.	859.	873.

Accessories and Client  
Samples

**Order Code**

Example: <b>RWHDHTB30H5( )</b>
<b>R</b> Reff
<b>WH</b> Wall hung
<b>DH</b> Desk height planning
<b>TB</b> Tackboard
<b>30</b> Width
<b>H5</b> 42 5/8" high
<b>W281</b> Fabric selection

**Specification Information**

To order please specify pattern number including;  
 1. Finish: Fabric

**Application Notes**

H5 Height = Top of Single high overhead to top of 1 1/2" thick desk height worksurface.

# Desk Screens

## Planning Guidelines and Specifications

### Reff Screens

Reff screens provide partial enclosure for workspaces to a nominal horizon of 42"—seated visual access—or 49"—seated visual privacy. Screens are available in a variety of surface finishes for aesthetics, performance and price point.

### Desk Mounted Screens

Desk mounted screens provide enclosure both above and below the top, starting from either 9 3/8" or 21 7/8" above the floor for 26 1/2" high planning and from either 11 1/4" or 23 3/4" above the floor for 28 3/8" high planning. Desk mounted screens attach directly to the back of a desk top with two brackets that also define a 1 1/4" offset for wire management and clamp-on accessories. Bracket centers are located 3 1/4" from each end of screens 24"-30" wide and 12" from each end of screens 36" and wider.

Screens are available in the following widths 24", 27", 30", and 36"-72" wide in 6" increments. In most applications screens can be mounted to matching width or wider tops.

### Two types of screens are available:

- Frameless laminate, marker surface or veneer screens are 3/4" thick with matching edge and crisp, eased corners.
- Fabric screens are 1 1/4" thick, with painted perimeter frame capturing a wood structural core and tackable, fabric wrapped inserts on each face.

### Specification Options

For frameless screens surface type: laminate (L) or veneer (V); specify finish, any core laminate or dry-erase marker surface (M), or any core Techwood or natural veneer. Also specify bracket color, in any Reff Profiles core paint finish.

For fabric screens specify fabric, perimeter frame and brackets painted finishes. Fabric is oriented railroad style for screens wider than 60".

Bracket and frame paint finish codes with suffix "T" indicate textured.

### Construction

Frameless screens are 3/4" MDF construction, with threaded inserts at bracket locations.

Fabric screens have a 1/2" MDF core, with 3/8" thick tackable PET material inserts on each side wrapped in fabric, and aluminum perimeter frame with seamless corners. Fabric screens have threaded metal inserts at bracket locations.

Laminate screens are edged with color matching ABS edgeband. Marker surface screens are edged with White ABS edgeband. Veneer screens are edged with matching veneer.

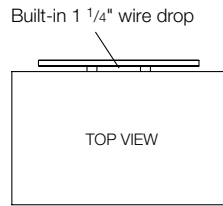

Screen always at back

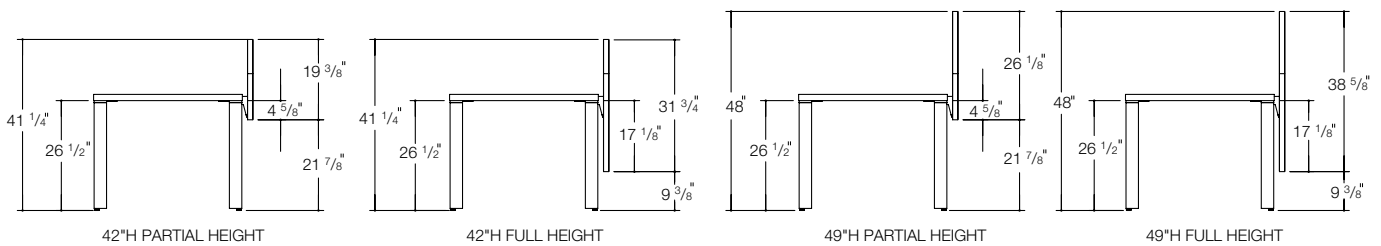

For applications with work surface 26 1/2" off the floor

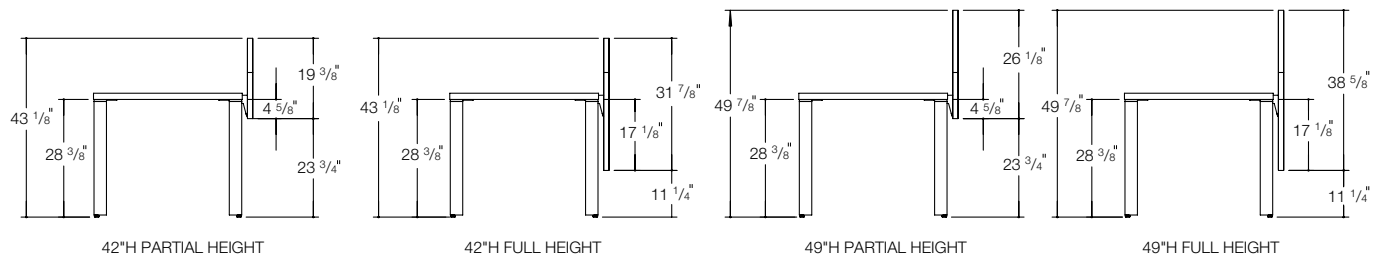

For applications with work surface 28 3/8" off the floor

Desk Screens  
*Fabric*  
 For 42" High Horizon

description	w	d	h	pattern no.	10	20	30	40	45
Fabric Screens with Partial Modesty For Desks, 42" High Horizon	24"	1 1/4"	20"	<b>YPSB2024F</b>	\$540.	\$567.	\$594.	\$621.	\$648.
	27"	1 1/4"	20"	<b>YPSB2027F</b>	555.	583.	611.	638.	666.
	30"	1 1/4"	20"	<b>YPSB2030F</b>	570.	599.	627.	656.	684.
	36"	1 1/4"	20"	<b>YPSB2036F</b>	635.	667.	699.	730.	762.
	42"	1 1/4"	20"	<b>YPSB2042F</b>	660.	693.	726.	759.	792.
	48"	1 1/4"	20"	<b>YPSB2048F</b>	680.	714.	748.	782.	816.
	54"	1 1/4"	20"	<b>YPSB2054F</b>	730.	767.	803.	840.	876.
	60"	1 1/4"	20"	<b>YPSB2060F</b>	775.	814.	853.	891.	930.
	66"	1 1/4"	20"	<b>YPSB2066FRR</b>	810.	851.	891.	932.	972.
72"	1 1/4"	20"	<b>YPSB2072FRR</b>	835.	877.	919.	960.	1,002.	

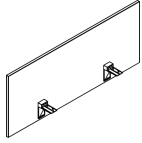

Fabric Screens with Half Modesty For Desks, 42" High Horizon	24"	1 1/4"	32"	<b>YPSB3224F</b>	625.	656.	688.	719.	750.
	27"	1 1/4"	32"	<b>YPSB3227F</b>	670.	704.	737.	771.	804.
	30"	1 1/4"	32"	<b>YPSB3230F</b>	690.	725.	759.	794.	828.
	36"	1 1/4"	32"	<b>YPSB3236F</b>	780.	819.	858.	897.	936.
	42"	1 1/4"	32"	<b>YPSB3242F</b>	825.	866.	908.	949.	990.
	48"	1 1/4"	32"	<b>YPSB3248F</b>	830.	872.	913.	955.	996.
	54"	1 1/4"	32"	<b>YPSB3254F</b>	900.	945.	990.	1,035.	1,080.
	60"	1 1/4"	32"	<b>YPSB3260F</b>	975.	1,024.	1,073.	1,121.	1,170.
	66"	1 1/4"	32"	<b>YPSB3266FRR</b>	1,110.	1,166.	1,221.	1,277.	1,332.
	72"	1 1/4"	32"	<b>YPSB3272FRR</b>	1,170.	1,229.	1,287.	1,346.	1,404.

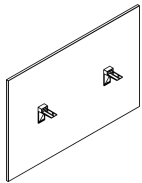

**Ordering Information**

**Desk Screens**

1. Pattern Number
2. Inside Fabric Finish
3. Outside Fabric Finish
4. Frame Paint Finish
5. Bracket Paint Finish

**Order Code**

**Desk Screens**

*Example:* **YPSB2048F, W351, W351, 118T, 118T**

<b>YPSB</b>	Desk Screen
<b>20</b>	Height
<b>48</b>	Width
<b>F</b>	Fabric
<b>W351</b>	Foundation
<b>W351</b>	Foundation
<b>118T</b>	Bright White Paint
<b>118T</b>	Bright White Paint

**Included With**

**Desk Screens**  
 Brackets  
 Hardware

**Options**

**Desk Screens**

The price of screens specified with a combination of fabrics is the higher of the two fabric grades.

Desk Screens  
*Fabric*  
 For 49" High Horizon

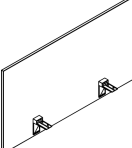
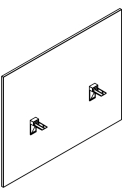
description	w	d	h	pattern no.	10	20	30	40	45
Fabric Screens with Partial Modesty For Desks, 49" High Horizon 	24"	1 1/4"	26"	<b>YPSB2624F</b>	\$590.	\$620.	\$649.	\$679.	\$708.
	27"	1 1/4"	26"	<b>YPSB2627F</b>	615.	646.	677.	707.	738.
	30"	1 1/4"	26"	<b>YPSB2630F</b>	630.	662.	693.	725.	756.
	36"	1 1/4"	26"	<b>YPSB2636F</b>	705.	740.	776.	811.	846.
	42"	1 1/4"	26"	<b>YPSB2642F</b>	740.	777.	814.	851.	888.
	48"	1 1/4"	26"	<b>YPSB2648F</b>	795.	835.	875.	914.	954.
	54"	1 1/4"	26"	<b>YPSB2654F</b>	850.	893.	935.	978.	1,020.
	60"	1 1/4"	26"	<b>YPSB2660F</b>	885.	929.	974.	1,018.	1,062.
	66"	1 1/4"	26"	<b>YPSB2666FRR</b>	925.	971.	1,018.	1,064.	1,110.
	72"	1 1/4"	26"	<b>YPSB2672FRR</b>	965.	1,013.	1,062.	1,110.	1,158.
Fabric Screens with Half Modesty For Desks, 49" High Horizon 	24"	1 1/4"	38"	<b>YPSB3824F</b>	675.	709.	743.	776.	810.
	27"	1 1/4"	38"	<b>YPSB3827F</b>	725.	761.	798.	834.	870.
	30"	1 1/4"	38"	<b>YPSB3830F</b>	745.	782.	820.	857.	894.
	36"	1 1/4"	38"	<b>YPSB3836F</b>	850.	893.	935.	978.	1,020.
	42"	1 1/4"	38"	<b>YPSB3842F</b>	900.	945.	990.	1,035.	1,080.
	48"	1 1/4"	38"	<b>YPSB3848F</b>	970.	1,019.	1,067.	1,116.	1,164.
	54"	1 1/4"	38"	<b>YPSB3854F</b>	1,020.	1,071.	1,122.	1,173.	1,224.
	60"	1 1/4"	38"	<b>YPSB3860F</b>	1,075.	1,129.	1,183.	1,236.	1,290.
	66"	1 1/4"	38"	<b>YPSB3866FRR</b>	1,205.	1,265.	1,326.	1,386.	1,446.
	72"	1 1/4"	38"	<b>YPSB3872FRR</b>	1,270.	1,334.	1,397.	1,461.	1,524.

**Ordering Information**

**Desk Screens**

1. Pattern Number
2. Inside Fabric Finish
3. Outside Fabric Finish
4. Frame Paint Finish
5. Bracket Paint Finish

**Order Code**

**Desk Screens**

*Example:* **YPSB2648F, W351, W351, 118T, 118T**

<b>YPSB</b>	Desk Screen
<b>26</b>	Height
<b>48</b>	Width
<b>F</b>	Fabric
<b>W351</b>	Foundation
<b>W351</b>	Foundation
<b>118T</b>	Bright White Paint
<b>118T</b>	Bright White Paint

**Included With**

**Desk Screens**  
 Brackets  
 Hardware

**Options**

**Desk Screens**

The price of screens specified with a combination of fabrics is the higher of the two fabric grades.

Desk Screens  
Laminate  
For 42" High Horizon

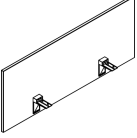
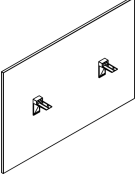
description	w	d	h	pattern no.	list
Laminate Screens with Partial Modesty For Desks, 42" High Horizon 	24"	3/4"	20"	YPSB2024L	\$221.
	27"	3/4"	20"	YPSB2027L	224.
	30"	3/4"	20"	YPSB2030L	226.
	36"	3/4"	20"	YPSB2036L	254.
	42"	3/4"	20"	YPSB2042L	260.
	48"	3/4"	20"	YPSB2048L	336.
	54"	3/4"	20"	YPSB2054L	342.
	60"	3/4"	20"	YPSB2060L	347.
	66"	3/4"	20"	YPSB2066L	353.
	72"	3/4"	20"	YPSB2072L	358.
Laminate Screens with Half Modesty For Desks, 42" High Horizon 	24"	3/4"	32"	YPSB3224L	248.
	27"	3/4"	32"	YPSB3227L	252.
	30"	3/4"	32"	YPSB3230L	287.
	36"	3/4"	32"	YPSB3236L	339.
	42"	3/4"	32"	YPSB3242L	347.
	48"	3/4"	32"	YPSB3248L	365.
	54"	3/4"	32"	YPSB3254L	373.
	60"	3/4"	32"	YPSB3260L	509.
	66"	3/4"	32"	YPSB3266L	517.
	72"	3/4"	32"	YPSB3272L	525.

Accessories and Client  
Samples

Ordering Information

Desk Screens

1. Pattern Number
2. Laminate Finish
3. Bracket Paint Finish

Order Code

Desk Screens

Example: YPSB2048L, 118, 118T

YPSB	Desk Screen
20	Height
48	Width
L	Laminate
118	Bright White Laminate
118T	Bright White Paint

Included With

Desk Screens  
Brackets  
Hardware

Options

Desk Screens

Desk Screens  
*Laminate*  
 For 49" High Horizon

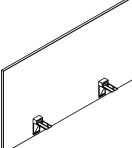
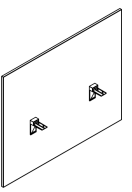
description	w	d	h	pattern no.	list
Laminate Screens with Partial Modesty, For Desks, 49" High Horizon 	24"	3/4"	26"	<b>YPSB2624L</b>	\$242.
	27"	3/4"	26"	<b>YPSB2627L</b>	245.
	30"	3/4"	26"	<b>YPSB2630L</b>	249.
	36"	3/4"	26"	<b>YPSB2636L</b>	255.
	42"	3/4"	26"	<b>YPSB2642L</b>	293.
	48"	3/4"	26"	<b>YPSB2648L</b>	320.
	54"	3/4"	26"	<b>YPSB2654L</b>	327.
	60"	3/4"	26"	<b>YPSB2660L</b>	345.
	66"	3/4"	26"	<b>YPSB2666L</b>	352.
	72"	3/4"	26"	<b>YPSB2672L</b>	451.
Laminate Screens with Half Modesty, For Desks, 49" High Horizon 	24"	3/4"	38"	<b>YPSB3824L</b>	286.
	27"	3/4"	38"	<b>YPSB3827L</b>	291.
	30"	3/4"	38"	<b>YPSB3830L</b>	295.
	36"	3/4"	38"	<b>YPSB3836L</b>	349.
	42"	3/4"	38"	<b>YPSB3842L</b>	359.
	48"	3/4"	38"	<b>YPSB3848L</b>	447.
	54"	3/4"	38"	<b>YPSB3854L</b>	457.
	60"	3/4"	38"	<b>YPSB3860L</b>	525.
	66"	3/4"	38"	<b>YPSB3866L</b>	534.
	72"	3/4"	38"	<b>YPSB3872L</b>	544.

**Ordering Information**

**Desk Screens**

1. Pattern Number
2. Laminate Finish
3. Bracket Paint Finish

**Order Code**

**Desk Screens**

*Example:* **YPSB2648L, 118, 118T**

<b>YPSB</b>	Desk Screen
<b>26</b>	Height
<b>48</b>	Width
<b>L</b>	Laminate
<b>118</b>	Bright White Laminate
<b>118T</b>	Bright White Paint

**Included With**

**Desk Screens**  
 Brackets  
 Hardware

**Options**

**Desk Screens**

Desk Screens  
*Markerboard*  
 For 42" High Horizon

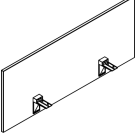
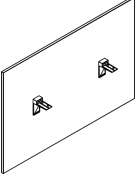
description	w	d	h	pattern no.	list
Markerboard Screens with Partial Modesty, For Desks, 42" High Horizon 	24"	3/4"	20"	<b>YPSB2024LM</b>	\$382.
	27"	3/4"	20"	<b>YPSB2027LM</b>	385.
	30"	3/4"	20"	<b>YPSB2030LM</b>	387.
	36"	3/4"	20"	<b>YPSB2036LM</b>	489.
	42"	3/4"	20"	<b>YPSB2042LM</b>	494.
	48"	3/4"	20"	<b>YPSB2048LM</b>	791.
	54"	3/4"	20"	<b>YPSB2054LM</b>	797.
	60"	3/4"	20"	<b>YPSB2060LM</b>	802.
	66"	3/4"	20"	<b>YPSB2066LM</b>	807.
72"	3/4"	20"	<b>YPSB2072LM</b>	813.	
Markerboard Screens with Half Modesty, For Desks, 42" High Horizon 	24"	3/4"	32"	<b>YPSB3224LM</b>	586.
	27"	3/4"	32"	<b>YPSB3227LM</b>	590.
	30"	3/4"	32"	<b>YPSB3230LM</b>	594.
	36"	3/4"	32"	<b>YPSB3236LM</b>	794.
	42"	3/4"	32"	<b>YPSB3242LM</b>	802.
	48"	3/4"	32"	<b>YPSB3248LM</b>	1,389.
	54"	3/4"	32"	<b>YPSB3254LM</b>	1,397.
	60"	3/4"	32"	<b>YPSB3260LM</b>	1,403.
	66"	3/4"	32"	<b>YPSB3266LM</b>	1,411.
72"	3/4"	32"	<b>YPSB3272LM</b>	1,420.	

Accessories and Client Samples

Ordering Information	Order Code	Included With	Options
<b>Desk Screens</b> 1. Pattern Number 2. Bracket Paint Finish	<b>Desk Screens</b> <i>Example:</i> <b>YPSB2048LM,118T</b> <b>YPSB</b> Desk Screen <b>20</b> Height <b>48</b> Width <b>LM</b> Markerboard <b>118T</b> Bright White Paint	<b>Desk Screens</b> Brackets Hardware	<b>Desk Screens</b>

Desk Screens  
*Markerboard*  
*For 49" High Horizon*

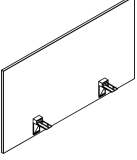
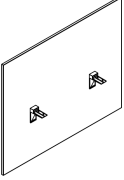
description	w	d	h	pattern no.	list
Markerboard Screens with Partial Modesty, For Desks, 49" High Horizon 	24"	3/4"	26"	<b>YPSB2624LM</b>	\$580.
	27"	3/4"	26"	<b>YPSB2627LM</b>	584.
	30"	3/4"	26"	<b>YPSB2630LM</b>	587.
	36"	3/4"	26"	<b>YPSB2636LM</b>	594.
	42"	3/4"	26"	<b>YPSB2642LM</b>	601.
	48"	3/4"	26"	<b>YPSB2648LM</b>	1,379.
	54"	3/4"	26"	<b>YPSB2654LM</b>	1,386.
	60"	3/4"	26"	<b>YPSB2660LM</b>	1,390.
	66"	3/4"	26"	<b>YPSB2666LM</b>	1,399.
72"	3/4"	26"	<b>YPSB2672LM</b>	1,404.	
Markerboard Screens with Half Modesty, For Desks, 49" High Horizon 	24"	3/4"	38"	<b>YPSB3824LM</b>	594.
	27"	3/4"	38"	<b>YPSB3827LM</b>	598.
	30"	3/4"	38"	<b>YPSB3830LM</b>	603.
	36"	3/4"	38"	<b>YPSB3836LM</b>	803.
	42"	3/4"	38"	<b>YPSB3842LM</b>	813.
	48"	3/4"	38"	<b>YPSB3848LM</b>	1,400.
	54"	3/4"	38"	<b>YPSB3854LM</b>	1,410.
	60"	3/4"	38"	<b>YPSB3860LM</b>	1,420.
	66"	3/4"	38"	<b>YPSB3866LM</b>	1,430.
72"	3/4"	38"	<b>YPSB3872LM</b>	1,440.	

**Ordering Information**

**Desk Screens**  
 1. Pattern Number  
 2. Bracket Paint Finish

**Order Code**

**Desk Screens**  
*Example:* **YPSB2648LM,118T**  
**YPSB** Desk Screen  
**20** Height  
**48** Width  
**LM** Markerboard  
**118T** Bright White Paint

**Included With**

**Desk Screens**  
 Brackets  
 Hardware

**Options**

**Desk Screens**



Desk Screens  
*Veneer*  
 For 42" High Horizon

Reff Profiles

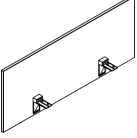
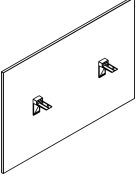
description	w	d	h	pattern no.	V1	V2	V3
Veneer Screens with Partial Modesty, For Desks, 42" High Horizon 	24"	3/4"	20"	<b>YPSB2024V</b>	\$423.	\$487.	\$633.
	27"	3/4"	20"	<b>YPSB2027V</b>	432.	497.	647.
	30"	3/4"	20"	<b>YPSB2030V</b>	442.	509.	661.
	36"	3/4"	20"	<b>YPSB2036V</b>	461.	530.	690.
	42"	3/4"	20"	<b>YPSB2042V</b>	495.	569.	740.
	48"	3/4"	20"	<b>YPSB2048V</b>	517.	595.	773.
	54"	3/4"	20"	<b>YPSB2054V</b>	537.	618.	803.
	60"	3/4"	20"	<b>YPSB2060V</b>	581.	668.	869.
	66"	3/4"	20"	<b>YPSB2066V</b>	607.	698.	907.
	72"	3/4"	20"	<b>YPSB2072V</b>	626.	720.	935.
Veneer Screens with Half Modesty For Desks, 42" High Horizon 	24"	3/4"	32"	<b>YPSB3224V</b>	492.	566.	736.
	27"	3/4"	32"	<b>YPSB3227V</b>	514.	591.	769.
	30"	3/4"	32"	<b>YPSB3230V</b>	529.	609.	791.
	36"	3/4"	32"	<b>YPSB3236V</b>	560.	644.	837.
	42"	3/4"	32"	<b>YPSB3242V</b>	614.	706.	918.
	48"	3/4"	32"	<b>YPSB3248V</b>	644.	740.	963.
	54"	3/4"	32"	<b>YPSB3254V</b>	680.	782.	1,017.
	60"	3/4"	32"	<b>YPSB3260V</b>	750.	862.	1,121.
	66"	3/4"	32"	<b>YPSB3266V</b>	786.	904.	1,175.
	72"	3/4"	32"	<b>YPSB3272V</b>	816.	938.	1,220.

Accessories and Client Samples

**Ordering Information**

**Desk Screens**

1. Pattern Number
2. Veneer Finish
3. Bracket Paint Finish

**Order Code**

**Desk Screens**  
*Example: YPSB2048V, V316, 118T*

<b>YPSB</b>	Desk Screen
<b>20</b>	Height
<b>48</b>	Width
<b>V</b>	Veneer
<b>V316</b>	Maple
<b>118T</b>	Bright White Paint

**Included With**

**Desk Screens**  
 Brackets  
 Hardware

**Options**

**Desk Screens**

Desk Screens  
*Veneer*  
*For 49" High Horizon*

Reff Profiles

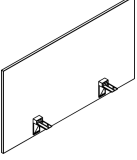
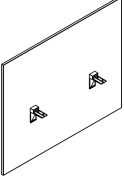
description	w	d	h	pattern no.	V1	V2	V3
Veneer Screens with Partial Modesty For Desks, 49" High Horizon 	24"	3/4"	26"	<b>YPSB2624V</b>	\$470.	\$541.	\$703.
	27"	3/4"	26"	<b>YPSB2627V</b>	482.	554.	721.
	30"	3/4"	26"	<b>YPSB2630V</b>	502.	578.	751.
	36"	3/4"	26"	<b>YPSB2636V</b>	527.	606.	788.
	42"	3/4"	26"	<b>YPSB2642V</b>	571.	656.	853.
	48"	3/4"	26"	<b>YPSB2648V</b>	602.	693.	901.
	54"	3/4"	26"	<b>YPSB2654V</b>	627.	720.	937.
	60"	3/4"	26"	<b>YPSB2660V</b>	698.	803.	1,043.
	66"	3/4"	26"	<b>YPSB2666V</b>	723.	831.	1,081.
	72"	3/4"	26"	<b>YPSB2672V</b>	748.	860.	1,118.
Veneer Screens with Half Modesty For Desks, 49" High Horizon 	24"	3/4"	38"	<b>YPSB3824V</b>	525.	604.	785.
	27"	3/4"	38"	<b>YPSB3827V</b>	543.	625.	812.
	30"	3/4"	38"	<b>YPSB3830V</b>	561.	645.	838.
	36"	3/4"	38"	<b>YPSB3836V</b>	604.	694.	903.
	42"	3/4"	38"	<b>YPSB3842V</b>	664.	764.	993.
	48"	3/4"	38"	<b>YPSB3848V</b>	700.	805.	1,046.
	54"	3/4"	38"	<b>YPSB3854V</b>	742.	853.	1,109.
	60"	3/4"	38"	<b>YPSB3860V</b>	837.	962.	1,251.
	66"	3/4"	38"	<b>YPSB3866V</b>	879.	1,011.	1,314.
	72"	3/4"	38"	<b>YPSB3872V</b>	915.	1,052.	1,368.

**Ordering Information**

**Desk Screens**

1. Pattern Number
2. Veneer Finish
3. Bracket Paint Finish

**Order Code**

**Desk Screens**

*Example:* **YPSB2648V, V316, 118T**

**YPSB** Desk Screen

**26** Height

**48** Width

**V** Veneer

**V316** Maple

**118T** Bright White Paint

**Included With**

**Desk Screens**

Brackets  
Hardware

**Options**

**Desk Screens**

description	w	d	pattern no.	L	V1	V2	V3
Desk Top Cubbies 30" and 36"	30"	10"	<b>RDTC3010( )</b>	\$829.	\$1,036.	\$1,191.	\$1,548.
	36"	10"	<b>RDTC3610( )</b>	836.	1,045.	1,202.	1,562.



Desk Top Cubbies 60" and 72"	60"	10"	<b>RDTC6010( )</b>	1,017.	1,272.	1,462.	1,901.
	72"	10"	<b>RDTC7210( )</b>	1,038.	1,298.	1,492.	1,940.

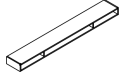

Desk Top Cubbies Open	60"	10"	<b>RDTCO6010( )</b>	1,124.	1,406.	1,616.	2,101.
	72"	10"	<b>RDTCO7210( )</b>	1,140.	1,424.	1,638.	2,129.

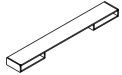

Wall Mounted Cubbies 30" and 36"	30"	10"	<b>RRMC3010( )</b>	909.	1,136.	1,306.	1,698.
	36"	10"	<b>RRMC3610( )</b>	917.	1,146.	1,318.	1,713.



Wall Mounted Cubbies 60" and 72"	60"	10"	<b>RRMC6010( )</b>	1,046.	1,306.	1,504.	1,955.
	72"	10"	<b>RRMC7210( )</b>	1,067.	1,334.	1,534.	1,995.



Under Mounted Cubbies 30" and 36"	30"	10"	<b>RUMC3010( )</b>	879.	1,099.	1,264.	1,643.
	36"	10"	<b>RUMC3610( )</b>	889.	1,112.	1,279.	1,662.



Order Code	Specification Information
Example: <b>RDTC3010( ) ( )</b>	
<b>R</b>	Reff
<b>DT</b>	Desk Top
<b>C</b>	Cubby
<b>30</b>	Width
<b>10</b>	Depth
	Finish

Application Notes
Installation instruction sheets available on line.
For Wall Mounted cubbies, please refer to part number 6TP00086.
For Under Mounted cubbies, please refer to part number 6TP00087.

description	w	d	pattern no.	L	V1	V2	V3
Under Mounted Cubbies 60" and 72"	60"	10"	<b>RUMC6010()</b>	\$998.	\$1,247.	\$1,434.	\$1,865.
	72"	10"	<b>RUMC7210()</b>	1,023.	1,278.	1,470.	1,911.

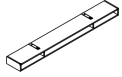

**Order Code**

Example: <b>RDTC3010()</b>	
<b>R</b>	Reff
<b>DT</b>	Desk Top
<b>C</b>	Cubby
<b>30</b>	Width
<b>10</b>	Depth
	Finish

**Specification Information**

**Application Notes**

Installation instruction sheets available on line.

For Wall Mounted cubbies, please refer to part number 6TP00086.

For Under Mounted cubbies, please refer to part number 6TP00087.

<b>Non-Wood Finishes</b>								
<b>Finishes</b>	<i>Panel Tiles, Tops &amp; Components</i>	<i>Panel Top Trims Window Frames</i>	<i>Panel Base Side Plates</i>	<i>Panel Beltway Side Plates*</i>	<i>Leg and Bases</i>	<i>Interaction Style Legs</i>	<i>Handles</i>	<i>Grommets</i>
Black	LG	LG	LG	LG	LG	LG	LG	LG
Dark grey	n/a	DG	DG	DG	DG	DG	n/a	DG
Medium grey	n/a	OI	OI	OI	OI	OI	n/a	OI
Charcoal grey	LD	LD	LD	LD	LD	LD	n/a	LD
Folkstone grey	LA	LA	LA	LA	LA	LA	n/a	LA
Oyster grey	LC	LC	LC	LC	LC	LC	n/a	LC
Pumice	LB	LB	LB	LB	LB	LB	n/a	LB
Willow grey	LE	LE	LE	LE	LE	LE	n/a	LE
Dark grey (metallic)	n/a	n/a	n/a	n/a	n/a	n/a	V	n/a
Medium grey (metallic)	n/a	n/a	n/a	n/a	n/a	n/a	J	n/a
Silver (metallic)	n/a	HPF	HPF	HPF	HPF	HPF	HPF	HPF
White	LH	LH	LH	LH	LH	LH	LH	LH
<b>Plated Finishes</b>								
Satin brass	n/a	n/a	PZ	n/a	PZ	n/a	PZ	PZ
Brushed pewter	n/a	n/a	PT	n/a	PT	n/a	PT	PT
Polished chrome	n/a	n/a	PD	n/a	PD	n/a	n/a	PD
<b>Currents Finishes</b>								
White	n/a	B	B	B	B	B	B	B
Metallic flint	n/a	2	2	2	2	2	2	2
Light metallic grey	n/a	U	U	U	U	U	U	U
Medium metallic grey	n/a	J	J	J	J	J	J	J
Dark metallic grey	n/a	V	V	V	V	V	V	V
Metallic beige	n/a	H	H	H	H	H	H	H
Light metallic tan	n/a	W	W	W	W	W	W	W
Soft grey	n/a	E	E	E	E	E	E	E
Medium Grey	n/a	Y2	Y2	Y2	Y2	Y2	Y2	Y2

n/a = not applicable

\*Beltway side plates not available in Satin brass, Brushed pewter or Polished chrome.

**Wall Mounting Suggestions**

The following information is provided only as a guide, and represents minimum recommendations only. Knoll does not accept responsibility for the attachment of any Knoll product to a Customer's site wall. Wall specification/construction is the responsibility of the Customer and its structural engineer/architect. Failure to properly attach Knoll products to adequate wall structures can lead to property damage and/or personal injury.

You should consult your own structural engineers and/or architects and must not rely on the information provided herein.

It is the responsibility of the Customer and its structural engineers/architects to verify that the permanent structural walls (studs, blocks, solid masonry, etc.) on which the Knoll products are intended to be mounted are designed appropriately to support the product weight, PLUS 3 lbs. per linear inch for each useable shelf length

**NOTE: A cabinet's top is considered a "useable shelf" and MUST be included in the calculation of the total load for an overhead cabinet.**

It is the responsibility of the Customer and its structural engineer/architects to specify the fasteners and method for attaching the Knoll supplied wall mounting cleat, bracket, frame, etc. to the supporting wall and to confirm that the installers have adhered to these specifications. For all local building standards and codes, and additional requirements (including, but not limited to, seismic conditions) the Customer should always consult local code agencies.

	EXISTING CONSTRUCTION					
	NEW CONSTRUCTION	Cinder Block or Poured Concrete Masonry Wall	Wood Stud Wall, the studs being FULL HEIGHT to the roof/floor above	Wood Stud Wall, the studs being only Ceiling Height	Steel Stud Wall, the studs being FULL HEIGHT to the roof/floor above	Steel Stud Wall, the studs being only Ceiling Height
<b>Stud Specification</b>	Wood studs, grade #2 or better, 3 1/2" minimum width, <b>OR</b> Metal studs, minimum 25 gage thickness, 3 5/8" minimum width	The wall must be a minimum of 6" thick, and must be full height to the roof/ floor structure above	Wood studs must be Grade #2, or better, 3 1/2" minimum width	Wood studs must be Grade #2, or better, 3 1/2" minimum width	Metal studs must be minimum 25 gage thickness, 3 5/8" minimum width	Metal studs must be minimum 25 gage thickness, 3 5/8" minimum width
<b>Stud Centers</b>	Metal and wood studs must be spaced at 16" c/c maximum	N/A	Wood studs must be spaced at 16" c/c maximum	Wood studs must be spaced at 16" c/c maximum"	Metal studs must be spaced at 16" c/c maximum	Metal studs must be spaced at 16" c/c maximum
<b>Stud Height</b>	Metal and wood studs must extend upwards, and be securely attached to the roof/ floor structure above			Wood studs must be braced above the ceiling, and be securely attached to the roof/floor structure above  Affix #2 grade 'cap' across the top of the studs, then place diagonal studs from the top cap up to underside of the roof/ floor structure above		Metal studs must be braced above the ceiling, and be securely attached to the roof/floor structure above  Affix metal bracing 'cap' across the top of the studs, then place diagonal studs from the top cap up to underside of the roof / floor structure above
<b>Mounting the Knoll Supplied Cleat, Bracket, Frame, etc*</b>	Insert a 2" X 6" wood block, #2 grade or better, [or a Danback™ flexible wood backing system] horizontally between each of the studs to accommodate the full width of the cabinet, <b>and beyond to the next stud.</b>  Fasten the wood block to each stud using three screws at the ends of each block. (Fasten the Danback™ as directed by the manufacturer)  Fasten the Knoll supplied wall mounting cleat, bracket, frame, etc directly to each wood block every 6"  For wall mounting structures that have a rectangular frame-like configuration: fasten the top horizontal element of the frame to the wood blocking every 6", and fasten the lower horizontal element to each wall stud, using one fastener per stud.	Fasten the Knoll supplied cabinet wall mounting cleat, bracket, frame, etc. directly to the masonry wall every 6"  For wall mounting structures that have a rectangular frame-like configuration: fasten the top horizontal element of the frame to the wall every 6", and fasten the lower horizontal element to the wall every 16"	In the desired location of the cabinet mounting rail, remove an 8" high section of drywall the width of the cabinet, <b>and beyond to the next stud.</b>  Insert a 2" X 6" wood block, #2 grade or better, horizontally between each of the exposed studs.  Fasten the wood block to each stud using three screws at the ends of each block.  Replace the drywall and repair as desired.  Fasten the Knoll supplied wall mounting cleat, rail, frame, etc directly to the wood block every 6"  For wall mounting structures that have a rectangular frame-like configuration: fasten the top horizontal element of the frame to the wood blocking every 6", and fasten the lower horizontal element to each wall stud, using one fastener per stud.	In the desired location of the cabinet mounting rail, remove an 8" high section of drywall the width of the cabinet, <b>and beyond to the next stud.</b>  Insert a 2" X 6" wood block, #2 grade or better, horizontally between each of the exposed studs.  Fasten the wood block to each stud using three screws at the ends of each block.  Replace the drywall and repair as desired.  Fasten the Knoll supplied wall mounting cleat, rail, frame, etc directly to the wood block every 6"  For wall mounting structures that have a rectangular frame-like configuration: fasten the top horizontal element of the frame to the wood blocking every 6", and fasten the lower horizontal element to each wall stud, using one fastener per stud.	In the desired location of the cabinet mounting rail, remove an 8" high section of drywall the width of the cabinet, <b>and beyond to the next stud.</b>  Insert a 2" X 6" wood block, #2 grade or better, [or a Danback™ flexible wood backing system] horizontally between each of the exposed studs.  Fasten the wood block to each stud using three screws at the ends of each block.  Replace the drywall and repair as desired.  Fasten the Knoll supplied wall mounting cleat, rail, frame, etc directly to the wood block every 6"  For wall mounting structures that have a rectangular frame-like configuration: fasten the top horizontal element of the frame to the wood blocking every 6", and fasten the lower horizontal element to each wall stud, using one fastener per stud.	In the desired location of the cabinet mounting rail, remove an 8" high section of drywall the width of the cabinet, <b>and beyond to the next stud.</b>  Insert a 2" X 6" wood block, #2 grade or better, [or a Danback™ flexible wood backing system] horizontally between each of the exposed studs.  Fasten the wood block to each stud using three screws at the ends of each block.  Replace the drywall and repair as desired.  Fasten the Knoll supplied wall mounting cleat, rail, frame, etc directly to the wood block every 6"  For wall mounting structures that have a rectangular frame-like configuration: fasten the top horizontal element of the frame to the wood blocking every 6", and fasten the lower horizontal element to each wall stud, using one fastener per stud.
<b>*Graham Wall Hung Shelf</b>	The Graham Wall Hung Shelf Bracket (and others like it) requires full support behind the full height of the bracket  This should be accomplished by insertion of additional 2"X 6" wood blocking between the studs as defined above	Fasten the Knoll supplied wall mounting brackets directly to the masonry wall, using the holes provided in each bracket	The Graham Wall Hung Shelf Bracket (and others like it) requires full support behind the full height of the bracket  This should be accomplished by insertion of additional 2"X 6" wood blocking between the studs as defined above	The Graham Wall Hung Shelf Bracket (and others like it) requires full support behind the full height of the bracket  This should be accomplished by insertion of additional 2"X 6" wood blocking between the studs as defined above	The Graham Wall Hung Shelf Bracket (and others like it) requires full support behind the full height of the bracket  This should be accomplished by insertion of additional 2"X 6" wood blocking between the studs as defined above	The Graham Wall Hung Shelf Bracket (and others like it) requires full support behind the full height of the bracket  This should be accomplished by insertion of additional 2"X 6" wood blocking between the studs as defined above
<b>Fasten the Knoll supplied wall cleat with...</b>	#10 x 2 1/2" Grabber Woodys Screws or equiv. @ 6" c/c, screwed directly into the wood blocking	3/16" x 3 1/2" Tapcon Masonry Screws or equiv. @ 6" c/c with 1-1/4" embedment, screwed directly into the masonry wall	#10 x 2 1/2" Grabber Woodys Screws or equiv. @ 6" c/c, screwed directly into the wood blocking	#10 x 2 1/2" Grabber Woodys Screws or equiv. @ 6" c/c, screwed directly into the wood blocking	#10 x 2 1/2" Grabber Woodys Screws or equiv. @ 6" c/c, screwed directly into the wood blocking	#10 x 2 1/2" Grabber Woodys Screws or equiv. @ 6" c/c, screwed directly into the wood blocking

# Horizons - 28<sup>3</sup>/<sub>8</sub>" Planning

## Planning Guidelines and Specifications

Nominal  
Planning Horizons

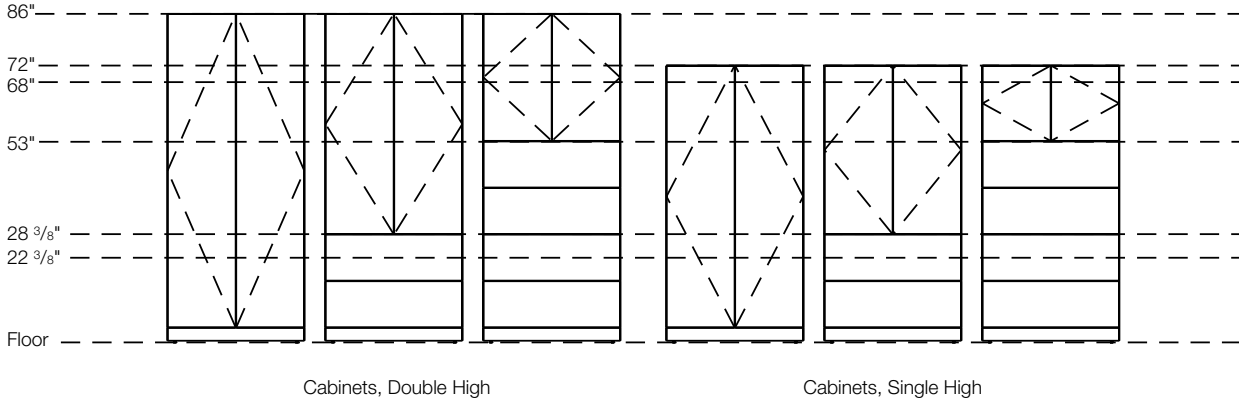

Nominal  
Planning Horizons

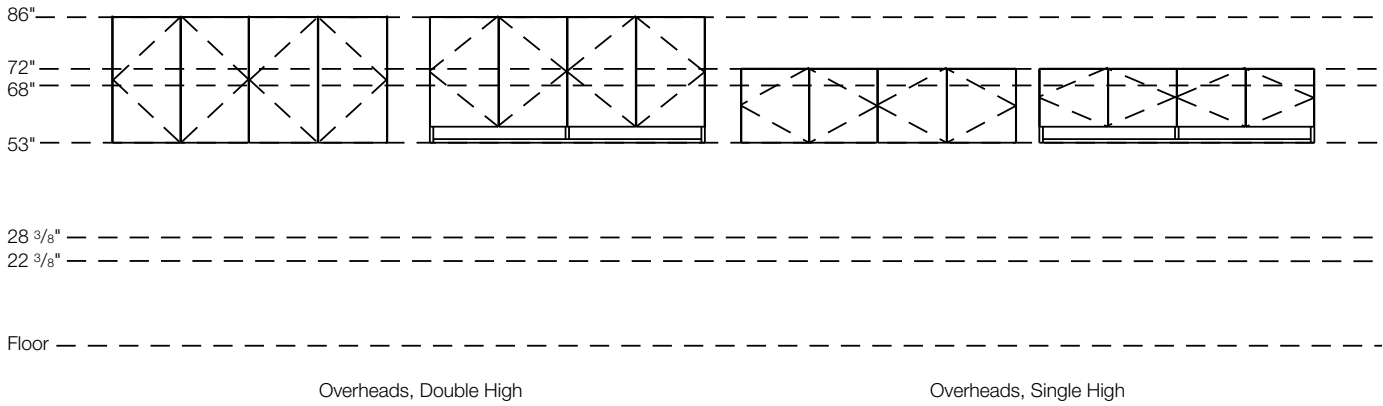

**Notes**

- Planning horizons are nominal. Dimensions are actual.
- Images displayed are examples only and do not represent the complete scope of products available.



# Horizons - 28<sup>3</sup>/<sub>8</sub>" Planning

## Planning Guidelines and Specifications

Nominal  
Planning Horizons

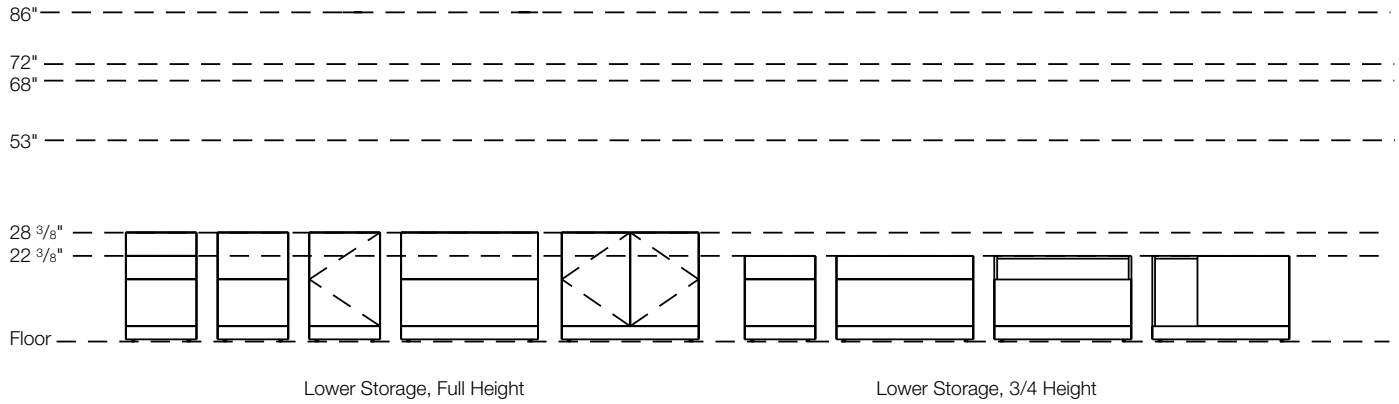

Nominal  
Planning Horizons

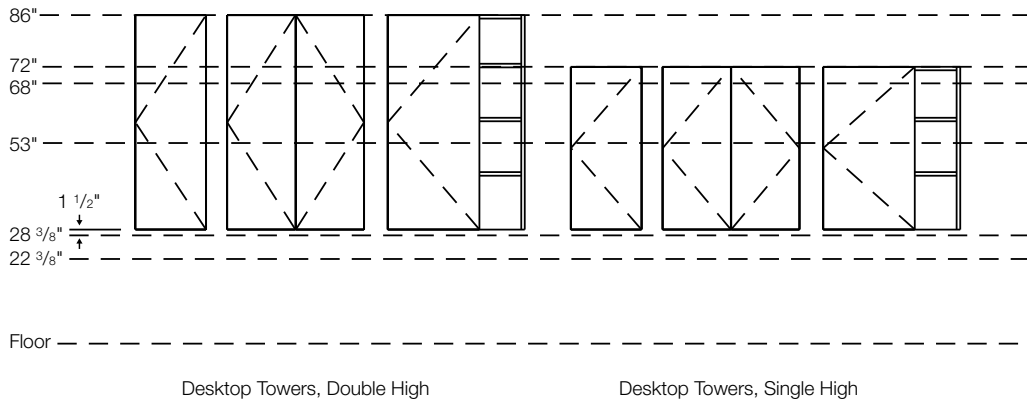

**Notes**

- Planning horizons are nominal. Dimensions are actual.
- Images displayed are examples only and do not represent the complete scope of products available.

# Horizons - 28<sup>3</sup>/<sub>8</sub>" Planning

## Planning Guidelines and Specifications

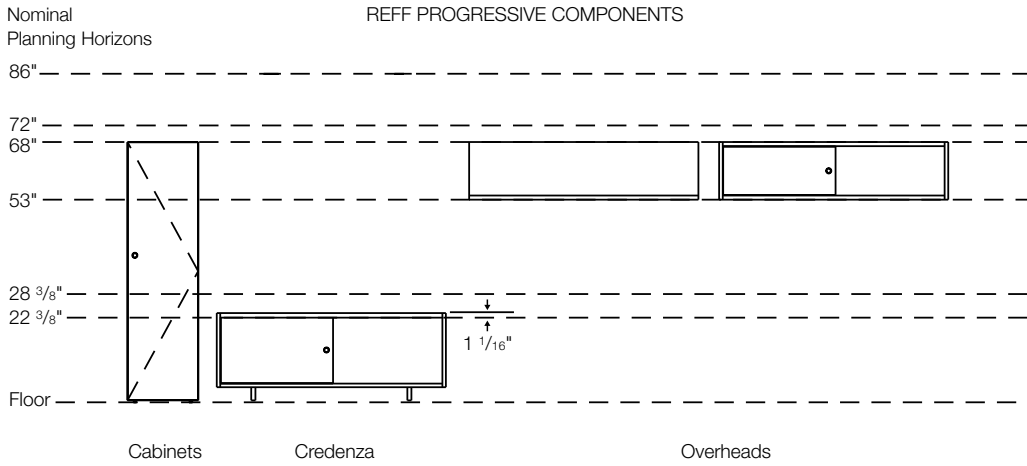

### Notes

- Planning horizons are nominal. Dimensions are actual.
- Images displayed are examples only and do not represent the complete scope of products available.

# Alpha-Numeric Index

<i>pattern no.</i>	<i>page</i>	<i>pattern no.</i>	<i>page</i>	<i>pattern no.</i>	<i>page</i>	<i>pattern no.</i>	<i>page</i>
ASBC18 (L/R)	236	R2ALPK42	80	R2B0TWC34 48	45	R2T49C(F/T)-(4/6)	112
ASBC24 (L/R)	236	R2ALPK49	80	R2CCG	117	R2T64C(F/T)-(4/6)	112
KRR2CAPEND	419	R2ALPK64	80	R2DLS7936	116	R2T79C(F/T)-(4/6)	112
KRR2CAPL	419	R2ALPK79	80	R2DLS7942	116	R2X42C	112
KRR2CAPSTRAIGHT	419	R2APT3418	77	R2DRS7936	116	R2X49C	112
KRR2CAPT	419	R2APT3420	77	R2DRS7942	116	R2X64C	112
KRR2CAPX	419	R2APT3424	77	R2ES42(A/B/C/E)(4/6)(E/N)	110	R2X79C	112
KRR3CAPEND	419	R2APT3430	77	R2ES42(A/B/C/E)(4/6)(E/N)	110	R3120Y34	109
KRR3CAPL	419	R2APT3436	77	R2ES49(A/B/C/E)(4/6)(E/N)	110	R3120Y42	109
KRR3CAPSTRAIGHT	419	R2APT3442	77	R2ES64(A/B/C/E)(4/6)(E/N)	110	R3120Y49	109
KRR3CAPT	419	R2APT3448	77	R2ES79(A/B/C/E)(4/6)(E/N)	110	R3120Y64	109
KRR3CAPX	419	R2APT4218	77	R2HK0008	419	R3120Y79	109
ML3L193M	397	R2APT4220	77	R2HK0015	419	R3135V34F	108
ML3L196M	397	R2APT4224	77	R2HK0034	419	R3135V34T	108
ML3L199M	397	R2APT4230	77	R2HK0042	419	R3135V42F	108
ML3L3712M	397	R2APT4236	77	R2HK0049	419	R3135V42T	108
ML3L3718M	397	R2APT4242	77	R2HK0064	419	R3135V49F	108
ML3L376M	397	R2APT4248	77	R2HK0079	419	R3135V49T	108
MWM-J	396	R2APT4918	78	R2HKB042	419	R3135V64F	108
R113B	238	R2APT4920	78	R2HKB049	419	R3135V64T	108
R234PKIT	117	R2APT4924	78	R2HKB064	419	R3135V79F	108
R2AETK34	80	R2APT4930	78	R2HKB079	419	R3135V79T	108
R2AETK42	80	R2APT4936	78	R2HL3442ES(A/B/C/E)	110	R334PKIT	117
R2AETK49	80	R2APT4942	78	R2HL3442(F)CS	111	R3AK	117
R2AETK64	80	R2APT4948	78	R2HL3449ES(A/B/C/E)	110	R3B0PAA42 18	16
R2AETK79	80	R2APT6418	78	R2HL3449(F)CS	111	R3B0PAA42 20	16
R2AHBW18	82	R2APT6420	78	R2HL3464ES(A/B/C/E)	110	R3B0PAA42 24	16
R2AHBW20	82	R2APT6424	78	R2HL3464(F/T)CS	111	R3B0PAA42 30	16
R2AHBW24	82	R2APT6430	78	R2HL3479ES(A/B/C/E)	110	R3B0PAA42 36	16
R2AHBW30	82	R2APT6436	78	R2HL3479(F/T)CS	111	R3B0PAA42 42	16
R2AHBW36	82	R2APT6442	78	R2HL4249ES(A/B/C/E)	110	R3B0PAA42 48	16
R2AHBW42	82	R2APT6448	78	R2HL4249ETS(A/B/C/E)	111	R3B0PAA42 60	16
R2AHBW48	82	R2APT7918	79	R2HL4249(F)CS	111	R3B0PAA42 66	16
R2AHCR34	81	R2APT7920	79	R2HL4264ES(A/B/C/E)	110	R3B0PAA42 72	16
R2AHCR42	81	R2APT7924	79	R2HL4264ETS(A/B/C/E)	111	R3B0PAA49 18	23
R2AHCR49	81	R2APT7930	79	R2HL4264(F/T)CS	111	R3B0PAA49 20	23
R2AHCR64	81	R2APT7936	79	R2HL4279ES(A/B/C/E)	110	R3B0PAA49 24	23
R2AHCR79	81	R2APT7942	79	R2HL4279ETS(A/B/C/E)	111	R3B0PAA49 30	23
R2AHSR18	83	R2APT7948	79	R2HL4279(F/T)CS	111	R3B0PAA49 36	23
R2AHSR20	83	R2ATPK34	79	R2HL4964ES(A/B/C/E)	110	R3B0PAA49 42	23
R2AHSR24	83	R2ATPK42	79	R2HL4964(F)CS	111	R3B0PAA49 48	23
R2AHSR30	83	R2ATPK49	79	R2HL4979ES(A/B/C/E)	110	R3B0PAA49 60	23
R2AHSR36	83	R2ATPK64	79	R2HL4979(F/T)CS	111	R3B0PAA49 66	23
R2AHSR42	83	R2ATPK79	79	R2HL6479ES(A/B/C/E)	110	R3B0PAA49 72	23
R2AHSR48	83	R2B0TWA34 18	45	R2HL6479(F)CS	111	R3B0PAA64 18	30
R2AHTR18	81	R2B0TWA34 20	45	R2L42C(F/T)(F/T)-(4/6)	112	R3B0PAA64 20	30
R2AHTR20	81	R2B0TWA34 24	45	R2L49C(F/T)(F/T)-(4/6)	112	R3B0PAA64 24	30
R2AHTR24	81	R2B0TWA34 30	45	R2L64C(F/T)(F/T)-(4/6)	112	R3B0PAA64 30	30
R2AHTR30	81	R2B0TWA34 36	45	R2L79C(F/T)(F/T)-(4/6)	112	R3B0PAA64 36	30
R2AHTR36	81	R2B0TWA34 42	45	R2S42C(F/T)(F/T)-(4/6)	112	R3B0PAA64 42	30
R2AHTR42	81	R2B0TWA34 48	45	R2S49C(F/T)(F/T)-(4/6)	112	R3B0PAA64 48	30
R2AHTR48	81	R2B0TWB34 30	45	R2S64C(F/T)(F/T)-(4/6)	112	R3B0PAA64 60	30
R2AHWR18	82	R2B0TWB34 36	45	R2S79C(F/T)(F/T)-(4/6)	112	R3B0PAA64 66	30
R2AHWR20	82	R2B0TWB34 42	45	R2SWS0008	114	R3B0PAA64 72	30
R2AHWR24	82	R2B0TWB34 48	45	R2SWS0015	114	R3B0PAA79 18	37
R2AHWR30	82	R2B0TWC34 18	45	R2SWS0034	114	R3B0PAA79 20	37
R2AHWR36	82	R2B0TWC34 20	45	R2SWS0042	114	R3B0PAA79 24	37
R2AHWR42	82	R2B0TWC34 24	45	R2SWS0049	114	R3B0PAA79 30	37
R2AHWR48	82	R2B0TWC34 30	45	R2SWS0064	114	R3B0PAA79 36	37
R2AK	117	R2B0TWC34 36	45	R2SWS0079	114	R3B0PAA79 42	37
R2ALPK34	80	R2B0TWC34 42	45	R2T42C(F/T)-(4/6)	112	R3B0PAA79 48	37

<i>pattern no.</i>	<i>page</i>	<i>pattern no.</i>	<i>page</i>	<i>pattern no.</i>	<i>page</i>	<i>pattern no.</i>	<i>page</i>
R3BOPAA79 60	37	R3BOPF242 66	20	R3BOPF364 48	35	R3BOPFL34 36	11
R3BOPAA79 66	37	R3BOPF242 72	20	R3BOPF364 60	35	R3BOPFL34 42	11
R3BOPAA79 72	37	R3BOPF249 18	27	R3BOPF364 66	35	R3BOPFL34 48	11
R3BOPF134 18	12	R3BOPF249 20	27	R3BOPF364 72	35	R3BOPFL42 18	18
R3BOPF134 20	12	R3BOPF249 24	27	R3BOPF379 18	42	R3BOPFL42 20	18
R3BOPF134 24	12	R3BOPF249 30	27	R3BOPF379 20	42	R3BOPFL42 24	18
R3BOPF134 30	12	R3BOPF249 36	27	R3BOPF379 24	42	R3BOPFL42 30	18
R3BOPF134 36	12	R3BOPF249 42	27	R3BOPF379 30	42	R3BOPFL42 36	18
R3BOPF134 42	12	R3BOPF249 48	27	R3BOPF379 36	42	R3BOPFL42 42	18
R3BOPF134 48	12	R3BOPF249 60	27	R3BOPF379 42	42	R3BOPFL42 48	18
R3BOPF142 18	19	R3BOPF249 66	27	R3BOPF379 48	42	R3BOPFL42 60	18
R3BOPF142 20	19	R3BOPF249 72	27	R3BOPF379 60	42	R3BOPFL42 66	18
R3BOPF142 24	19	R3BOPF264 18	34	R3BOPF379 66	42	R3BOPFL42 72	18
R3BOPF142 30	19	R3BOPF264 20	34	R3BOPF379 72	42	R3BOPFL49 18	25
R3BOPF142 36	19	R3BOPF264 24	34	R3BOPFF34 18	10	R3BOPFL49 20	25
R3BOPF142 42	19	R3BOPF264 30	34	R3BOPFF34 20	10	R3BOPFL49 24	25
R3BOPF142 48	19	R3BOPF264 36	34	R3BOPFF34 24	10	R3BOPFL49 30	25
R3BOPF142 60	19	R3BOPF264 42	34	R3BOPFF34 30	10	R3BOPFL49 36	25
R3BOPF142 66	19	R3BOPF264 48	34	R3BOPFF34 36	10	R3BOPFL49 42	25
R3BOPF142 72	19	R3BOPF264 60	34	R3BOPFF34 42	10	R3BOPFL49 48	25
R3BOPF149 18	26	R3BOPF264 66	34	R3BOPFF34 48	10	R3BOPFL49 60	25
R3BOPF149 20	26	R3BOPF264 72	34	R3BOPFF42 18	16	R3BOPFL49 66	25
R3BOPF149 24	26	R3BOPF279 18	41	R3BOPFF42 20	16	R3BOPFL49 72	25
R3BOPF149 30	26	R3BOPF279 20	41	R3BOPFF42 24	16	R3BOPFL64 18	32
R3BOPF149 36	26	R3BOPF279 24	41	R3BOPFF42 30	16	R3BOPFL64 20	32
R3BOPF149 42	26	R3BOPF279 30	41	R3BOPFF42 36	16	R3BOPFL64 24	32
R3BOPF149 48	26	R3BOPF279 36	41	R3BOPFF42 42	16	R3BOPFL64 30	32
R3BOPF149 60	26	R3BOPF279 42	41	R3BOPFF42 48	16	R3BOPFL64 36	32
R3BOPF149 66	26	R3BOPF279 48	41	R3BOPFF42 60	16	R3BOPFL64 42	32
R3BOPF149 72	26	R3BOPF279 60	41	R3BOPFF42 66	16	R3BOPFL64 48	32
R3BOPF164 18	33	R3BOPF279 66	41	R3BOPFF42 72	16	R3BOPFL64 60	32
R3BOPF164 20	33	R3BOPF279 72	41	R3BOPFF49 18	23	R3BOPFL64 66	32
R3BOPF164 24	33	R3BOPF334 18	14	R3BOPFF49 20	23	R3BOPFL64 72	32
R3BOPF164 30	33	R3BOPF334 20	14	R3BOPFF49 24	23	R3BOPFL79 18	39
R3BOPF164 36	33	R3BOPF334 24	14	R3BOPFF49 30	23	R3BOPFL79 20	39
R3BOPF164 42	33	R3BOPF334 30	14	R3BOPFF49 36	23	R3BOPFL79 24	39
R3BOPF164 48	33	R3BOPF334 36	14	R3BOPFF49 42	23	R3BOPFL79 30	39
R3BOPF164 60	33	R3BOPF334 42	14	R3BOPFF49 48	23	R3BOPFL79 36	39
R3BOPF164 66	33	R3BOPF334 48	14	R3BOPFF49 60	23	R3BOPFL79 42	39
R3BOPF164 72	33	R3BOPF342 18	21	R3BOPFF49 66	23	R3BOPFL79 48	39
R3BOPF179 18	40	R3BOPF342 20	21	R3BOPFF49 72	23	R3BOPFL79 60	39
R3BOPF179 20	40	R3BOPF342 24	21	R3BOPFF64 18	30	R3BOPFL79 66	39
R3BOPF179 24	40	R3BOPF342 30	21	R3BOPFF64 20	30	R3BOPFL79 72	39
R3BOPF179 30	40	R3BOPF342 36	21	R3BOPFF64 24	30	R3BOPLL3418	15
R3BOPF179 36	40	R3BOPF342 42	21	R3BOPFF64 30	30	R3BOPLL3420	15
R3BOPF179 42	40	R3BOPF342 48	21	R3BOPFF64 36	30	R3BOPLL3424	15
R3BOPF179 48	40	R3BOPF342 60	21	R3BOPFF64 42	30	R3BOPLL3430	15
R3BOPF179 60	40	R3BOPF342 66	21	R3BOPFF64 48	30	R3BOPLL3436	15
R3BOPF179 66	40	R3BOPF342 72	21	R3BOPFF64 60	30	R3BOPLL3442	15
R3BOPF179 72	40	R3BOPF349 18	28	R3BOPFF64 66	30	R3BOPLL3448	15
R3BOPF234 18	13	R3BOPF349 20	28	R3BOPFF64 72	30	R3BOPLL4218	22
R3BOPF234 20	13	R3BOPF349 24	28	R3BOPFF79 18	37	R3BOPLL4220	22
R3BOPF234 24	13	R3BOPF349 30	28	R3BOPFF79 20	37	R3BOPLL4224	22
R3BOPF234 30	13	R3BOPF349 36	28	R3BOPFF79 24	37	R3BOPLL4230	22
R3BOPF234 36	13	R3BOPF349 42	28	R3BOPFF79 30	37	R3BOPLL4236	22
R3BOPF234 42	13	R3BOPF349 48	28	R3BOPFF79 36	37	R3BOPLL4242	22
R3BOPF234 48	13	R3BOPF349 60	28	R3BOPFF79 42	37	R3BOPLL4248	22
R3BOPF242 18	20	R3BOPF349 66	28	R3BOPFF79 48	37	R3BOPLL4260	22
R3BOPF242 20	20	R3BOPF349 72	28	R3BOPFF79 60	37	R3BOPLL4266	22
R3BOPF242 24	20	R3BOPF364 18	35	R3BOPFF79 66	37	R3BOPLL4272	22
R3BOPF242 30	20	R3BOPF364 20	35	R3BOPFF79 72	37	R3BOPLL4918	29
R3BOPF242 36	20	R3BOPF364 24	35	R3BOPFL34 18	11	R3BOPLL4920	29
R3BOPF242 42	20	R3BOPF364 30	35	R3BOPFL34 20	11	R3BOPLL4924	29
R3BOPF242 48	20	R3BOPF364 36	35	R3BOPFL34 24	11	R3BOPLL4930	29
R3BOPF242 60	20	R3BOPF364 42	35	R3BOPFL34 30	11	R3BOPLL4936	29

<i>pattern no.</i>	<i>page</i>	<i>pattern no.</i>	<i>page</i>	<i>pattern no.</i>	<i>page</i>	<i>pattern no.</i>	<i>page</i>
R3BOPLL4942	29	R3B0TF142 42	52	R3B0TF342 18	54	R3B0TFL34 24	46
R3BOPLL4948	29	R3B0TF142 48	52	R3B0TF342 20	54	R3B0TFL34 30	46
R3BOPLL4960	29	R3B0TF149 18	59	R3B0TF342 24	54	R3B0TFL34 36	46
R3BOPLL4966	29	R3B0TF149 20	59	R3B0TF342 30	54	R3B0TFL34 42	46
R3BOPLL4972	29	R3B0TF149 24	59	R3B0TF342 36	54	R3B0TFL34 48	46
R3BOPLL6418	36	R3B0TF149 30	59	R3B0TF342 42	54	R3B0TFL42 18	51
R3BOPLL6420	36	R3B0TF149 36	59	R3B0TF342 48	54	R3B0TFL42 20	51
R3BOPLL6424	36	R3B0TF149 42	59	R3B0TF349 18	61	R3B0TFL42 24	51
R3BOPLL6430	36	R3B0TF149 48	59	R3B0TF349 20	61	R3B0TFL42 30	51
R3BOPLL6436	36	R3B0TF164 18	66	R3B0TF349 24	61	R3B0TFL42 36	51
R3BOPLL6442	36	R3B0TF164 20	66	R3B0TF349 30	61	R3B0TFL42 42	51
R3BOPLL6448	36	R3B0TF164 24	66	R3B0TF349 36	61	R3B0TFL42 48	51
R3BOPLL6460	36	R3B0TF164 30	66	R3B0TF349 42	61	R3B0TFL49 18	58
R3BOPLL6466	36	R3B0TF164 36	66	R3B0TF349 48	61	R3B0TFL49 20	58
R3BOPLL6472	36	R3B0TF164 42	66	R3B0TF364 18	68	R3B0TFL49 24	58
R3BOPLL7918	43	R3B0TF164 48	66	R3B0TF364 20	68	R3B0TFL49 30	58
R3BOPLL7920	43	R3B0TF179 18	73	R3B0TF364 24	68	R3B0TFL49 36	58
R3BOPLL7924	43	R3B0TF179 20	73	R3B0TF364 30	68	R3B0TFL49 42	58
R3BOPLL7930	43	R3B0TF179 24	73	R3B0TF364 36	68	R3B0TFL49 48	58
R3BOPLL7936	43	R3B0TF179 30	73	R3B0TF364 42	68	R3B0TFL64 18	65
R3BOPLL7942	43	R3B0TF179 36	73	R3B0TF364 48	68	R3B0TFL64 20	65
R3BOPLL7948	43	R3B0TF179 42	73	R3B0TF379 18	75	R3B0TFL64 24	65
R3BOPLL7960	43	R3B0TF179 48	73	R3B0TF379 20	75	R3B0TFL64 30	65
R3BOPLL7966	43	R3B0TF234 18	47	R3B0TF379 24	75	R3B0TFL64 36	65
R3BOPLL7972	43	R3B0TF234 20	47	R3B0TF379 30	75	R3B0TFL64 42	65
R3B0TAA42 18	49	R3B0TF234 24	47	R3B0TF379 36	75	R3B0TFL64 48	65
R3B0TAA42 20	49	R3B0TF234 30	47	R3B0TF379 42	75	R3B0TFL79 18	72
R3B0TAA42 24	49	R3B0TF234 36	47	R3B0TF379 48	75	R3B0TFL79 20	72
R3B0TAA42 30	49	R3B0TF234 42	47	R3B0TFF34 18	44	R3B0TFL79 24	72
R3B0TAA42 36	49	R3B0TF234 48	47	R3B0TFF34 20	44	R3B0TFL79 30	72
R3B0TAA42 42	49	R3B0TF242 18	53	R3B0TFF34 24	44	R3B0TFL79 36	72
R3B0TAA42 48	49	R3B0TF242 20	53	R3B0TFF34 30	44	R3B0TFL79 42	72
R3B0TAA49 18	56	R3B0TF242 24	53	R3B0TFF34 36	44	R3B0TFL79 48	72
R3B0TAA49 20	56	R3B0TF242 30	53	R3B0TFF34 42	44	R3B0TLL3418	48
R3B0TAA49 24	56	R3B0TF242 36	53	R3B0TFF34 48	44	R3B0TLL3420	48
R3B0TAA49 30	56	R3B0TF242 42	53	R3B0TFF42 18	49	R3B0TLL3424	48
R3B0TAA49 36	56	R3B0TF242 48	53	R3B0TFF42 20	49	R3B0TLL3430	48
R3B0TAA49 42	56	R3B0TF249 18	60	R3B0TFF42 24	49	R3B0TLL3436	48
R3B0TAA49 48	56	R3B0TF249 20	60	R3B0TFF42 30	49	R3B0TLL3442	48
R3B0TAA64 18	63	R3B0TF249 24	60	R3B0TFF42 36	49	R3B0TLL3448	48
R3B0TAA64 20	63	R3B0TF249 30	60	R3B0TFF42 42	49	R3B0TLL4218	55
R3B0TAA64 24	63	R3B0TF249 36	60	R3B0TFF42 48	49	R3B0TLL4220	55
R3B0TAA64 30	63	R3B0TF249 42	60	R3B0TFF49 18	56	R3B0TLL4224	55
R3B0TAA64 36	63	R3B0TF249 48	60	R3B0TFF49 20	56	R3B0TLL4230	55
R3B0TAA64 42	63	R3B0TF264 18	67	R3B0TFF49 24	56	R3B0TLL4236	55
R3B0TAA64 48	63	R3B0TF264 20	67	R3B0TFF49 30	56	R3B0TLL4242	55
R3B0TAA79 18	70	R3B0TF264 24	67	R3B0TFF49 36	56	R3B0TLL4248	55
R3B0TAA79 20	70	R3B0TF264 30	67	R3B0TFF49 42	56	R3B0TLL4918	62
R3B0TAA79 24	70	R3B0TF264 36	67	R3B0TFF49 48	56	R3B0TLL4920	62
R3B0TAA79 30	70	R3B0TF264 42	67	R3B0TFF64 18	63	R3B0TLL4924	62
R3B0TAA79 36	70	R3B0TF264 48	67	R3B0TFF64 20	63	R3B0TLL4930	62
R3B0TAA79 42	70	R3B0TF279 18	74	R3B0TFF64 24	63	R3B0TLL4936	62
R3B0TAA79 48	70	R3B0TF279 20	74	R3B0TFF64 30	63	R3B0TLL4942	62
R3B0TF134 18	46	R3B0TF279 24	74	R3B0TFF64 36	63	R3B0TLL4948	62
R3B0TF134 20	46	R3B0TF279 30	74	R3B0TFF64 42	63	R3B0TLL6418	69
R3B0TF134 24	46	R3B0TF279 36	74	R3B0TFF64 48	63	R3B0TLL6420	69
R3B0TF134 30	46	R3B0TF279 42	74	R3B0TFF79 18	70	R3B0TLL6424	69
R3B0TF134 36	46	R3B0TF279 48	74	R3B0TFF79 20	70	R3B0TLL6430	69
R3B0TF134 42	46	R3B0TF334 18	47	R3B0TFF79 24	70	R3B0TLL6436	69
R3B0TF134 48	46	R3B0TF334 20	47	R3B0TFF79 30	70	R3B0TLL6442	69
R3B0TF142 18	52	R3B0TF334 24	47	R3B0TFF79 36	70	R3B0TLL6448	69
R3B0TF142 20	52	R3B0TF334 30	47	R3B0TFF79 42	70	R3B0TLL7918	76
R3B0TF142 24	52	R3B0TF334 36	47	R3B0TFF79 48	70	R3B0TLL7920	76
R3B0TF142 30	52	R3B0TF334 42	47	R3B0TFL34 18	46	R3B0TLL7924	76
R3B0TF142 36	52	R3B0TF334 48	47	R3B0TFL34 20	46	R3B0TLL7930	76

<i>pattern no.</i>	<i>page</i>	<i>pattern no.</i>	<i>page</i>	<i>pattern no.</i>	<i>page</i>	<i>pattern no.</i>	<i>page</i>
R3B0TLL7936	76	R3B1PF279 24	41	R3B1PFF49 30	24	R3B1PFLB49 36	89
R3B0TLL7942	76	R3B1PF279 30	41	R3B1PFF49 36	24	R3B1PFLB49 42	89
R3B0TLL7948	76	R3B1PF279 36	41	R3B1PFF49 42	24	R3B1PFLB49 48	89
R3B1PF142 18	19	R3B1PF279 42	41	R3B1PFF49 48	24	R3B1TF142 18	52
R3B1PF142 20	19	R3B1PF279 48	41	R3B1PFF64 18	31	R3B1TF142 20	52
R3B1PF142 24	19	R3B1PF2A49 18	95	R3B1PFF64 20	31	R3B1TF142 24	52
R3B1PF142 30	19	R3B1PF2A49 20	95	R3B1PFF64 24	31	R3B1TF142 30	52
R3B1PF142 36	19	R3B1PF2A49 24	95	R3B1PFF64 30	31	R3B1TF142 36	52
R3B1PF142 42	19	R3B1PF2A49 30	95	R3B1PFF64 36	31	R3B1TF142 42	52
R3B1PF142 48	19	R3B1PF2A49 36	95	R3B1PFF64 42	31	R3B1TF142 48	52
R3B1PF149 18	26	R3B1PF2A49 42	95	R3B1PFF64 48	31	R3B1TF149 18	59
R3B1PF149 20	26	R3B1PF2A49 48	95	R3B1PFF79 18	38	R3B1TF149 20	59
R3B1PF149 24	26	R3B1PF2B49 30	95	R3B1PFF79 20	38	R3B1TF149 24	59
R3B1PF149 30	26	R3B1PF2B49 36	95	R3B1PFF79 24	38	R3B1TF149 30	59
R3B1PF149 36	26	R3B1PF2B49 42	95	R3B1PFF79 30	38	R3B1TF149 36	59
R3B1PF149 42	26	R3B1PF2B49 48	95	R3B1PFF79 36	38	R3B1TF149 42	59
R3B1PF149 48	26	R3B1PF342 18	21	R3B1PFF79 42	38	R3B1TF149 48	59
R3B1PF164 18	33	R3B1PF342 20	21	R3B1PFF79 48	38	R3B1TF164 18	66
R3B1PF164 20	33	R3B1PF342 24	21	R3B1PFFA49 18	86	R3B1TF164 20	66
R3B1PF164 24	33	R3B1PF342 30	21	R3B1PFFA49 20	86	R3B1TF164 24	66
R3B1PF164 30	33	R3B1PF342 36	21	R3B1PFFA49 24	86	R3B1TF164 30	66
R3B1PF164 36	33	R3B1PF342 42	21	R3B1PFFA49 30	86	R3B1TF164 36	66
R3B1PF164 42	33	R3B1PF342 48	21	R3B1PFFA49 36	86	R3B1TF164 42	66
R3B1PF164 48	33	R3B1PF349 18	28	R3B1PFFA49 42	86	R3B1TF164 48	66
R3B1PF179 18	40	R3B1PF349 20	28	R3B1PFFA49 48	86	R3B1TF179 18	73
R3B1PF179 20	40	R3B1PF349 24	28	R3B1PFFB49 30	86	R3B1TF179 20	73
R3B1PF179 24	40	R3B1PF349 30	28	R3B1PFFB49 36	86	R3B1TF179 24	73
R3B1PF179 30	40	R3B1PF349 36	28	R3B1PFFB49 42	86	R3B1TF179 30	73
R3B1PF179 36	40	R3B1PF349 42	28	R3B1PFFB49 48	86	R3B1TF179 36	73
R3B1PF179 42	40	R3B1PF349 48	28	R3B1PFLA2 18	18	R3B1TF179 42	73
R3B1PF179 48	40	R3B1PF364 18	35	R3B1PFLA2 20	18	R3B1TF179 48	73
R3B1PFA49 18	92	R3B1PF364 20	35	R3B1PFLA2 24	18	R3B1TFA49 18	90
R3B1PFA49 20	92	R3B1PF364 24	35	R3B1PFLA2 30	18	R3B1TFA49 20	90
R3B1PFA49 24	92	R3B1PF364 30	35	R3B1PFLA2 36	18	R3B1TFA49 24	90
R3B1PFA49 30	92	R3B1PF364 36	35	R3B1PFLA2 42	18	R3B1TFA49 30	90
R3B1PFA49 36	92	R3B1PF364 42	35	R3B1PFLA2 48	18	R3B1TFA49 36	90
R3B1PFA49 42	92	R3B1PF364 48	35	R3B1PFLA9 18	25	R3B1TFA49 42	90
R3B1PFA49 48	92	R3B1PF379 18	42	R3B1PFLA9 20	25	R3B1TFA49 48	90
R3B1PFB49 30	92	R3B1PF379 20	42	R3B1PFLA9 24	25	R3B1TF1B49 30	91
R3B1PFB49 36	92	R3B1PF379 24	42	R3B1PFLA9 30	25	R3B1TF1B49 36	91
R3B1PFB49 42	92	R3B1PF379 30	42	R3B1PFLA9 36	25	R3B1TF1B49 42	91
R3B1PFB49 48	92	R3B1PF379 36	42	R3B1PFLA9 42	25	R3B1TF1B49 48	91
R3B1PF242 18	20	R3B1PF379 42	42	R3B1PFLA9 48	25	R3B1TF242 18	53
R3B1PF242 20	20	R3B1PF379 48	42	R3B1PFL64 18	32	R3B1TF242 20	53
R3B1PF242 24	20	R3B1PF3A49 18	97	R3B1PFL64 20	32	R3B1TF242 24	53
R3B1PF242 30	20	R3B1PF3A49 20	97	R3B1PFL64 24	32	R3B1TF242 30	53
R3B1PF242 36	20	R3B1PF3A49 24	97	R3B1PFL64 30	32	R3B1TF242 36	53
R3B1PF242 42	20	R3B1PF3A49 30	97	R3B1PFL64 36	32	R3B1TF242 42	53
R3B1PF242 48	20	R3B1PF3A49 36	97	R3B1PFL64 42	32	R3B1TF242 48	53
R3B1PF249 18	27	R3B1PF3A49 42	97	R3B1PFL64 48	32	R3B1TF249 18	60
R3B1PF249 20	27	R3B1PF3A49 48	97	R3B1PFL79 18	39	R3B1TF249 20	60
R3B1PF249 24	27	R3B1PF3B49 30	97	R3B1PFL79 20	39	R3B1TF249 24	60
R3B1PF249 30	27	R3B1PF3B49 36	97	R3B1PFL79 24	39	R3B1TF249 30	60
R3B1PF249 36	27	R3B1PF3B49 42	97	R3B1PFL79 30	39	R3B1TF249 36	60
R3B1PF249 42	27	R3B1PF3B49 48	97	R3B1PFL79 36	39	R3B1TF249 42	60
R3B1PF249 48	27	R3B1PFF42 18	17	R3B1PFL79 42	39	R3B1TF249 48	60
R3B1PF264 18	34	R3B1PFF42 20	17	R3B1PFL79 48	39	R3B1TF264 18	67
R3B1PF264 20	34	R3B1PFF42 24	17	R3B1PFLA49 18	89	R3B1TF264 20	67
R3B1PF264 24	34	R3B1PFF42 30	17	R3B1PFLA49 20	89	R3B1TF264 24	67
R3B1PF264 30	34	R3B1PFF42 36	17	R3B1PFLA49 24	89	R3B1TF264 30	67
R3B1PF264 36	34	R3B1PFF42 42	17	R3B1PFLA49 30	89	R3B1TF264 36	67
R3B1PF264 42	34	R3B1PFF42 48	17	R3B1PFLA49 36	89	R3B1TF264 42	67
R3B1PF264 48	34	R3B1PFF49 18	24	R3B1PFLA49 42	89	R3B1TF264 48	67
R3B1PF279 18	41	R3B1PFF49 20	24	R3B1PFLA49 48	89	R3B1TF279 18	74
R3B1PF279 20	41	R3B1PFF49 24	24	R3B1PFLB49 30	89	R3B1TF279 20	74

<i>pattern no.</i>	<i>page</i>	<i>pattern no.</i>	<i>page</i>	<i>pattern no.</i>	<i>page</i>	<i>pattern no.</i>	<i>page</i>
R3B1TF279 24	74	R3B1TFF49 30	57	R3B1TFLB49 36	88	R3B2TFF79 24	71
R3B1TF279 30	74	R3B1TFF49 36	57	R3B1TFLB49 42	88	R3B2TFF79 30	71
R3B1TF279 36	74	R3B1TFF49 42	57	R3B1TFLB49 48	88	R3B2TFF79 36	71
R3B1TF279 42	74	R3B1TFF49 48	57	R3B2PFF42 18	17	R3B2TFF79 42	71
R3B1TF279 48	74	R3B1TFF64 18	64	R3B2PFF42 20	17	R3B2TFF79 48	71
R3B1TF2A49 18	93	R3B1TFF64 20	64	R3B2PFF42 24	17	R3B2TFFA49 18	98
R3B1TF2A49 20	93	R3B1TFF64 24	64	R3B2PFF42 30	17	R3B2TFFA49 20	98
R3B1TF2A49 24	93	R3B1TFF64 30	64	R3B2PFF42 36	17	R3B2TFFA49 24	98
R3B1TF2A49 30	93	R3B1TFF64 36	64	R3B2PFF42 42	17	R3B2TFFA49 30	98
R3B1TF2A49 36	93	R3B1TFF64 42	64	R3B2PFF42 48	17	R3B2TFFA49 36	98
R3B1TF2A49 42	93	R3B1TFF64 48	64	R3B2PFF49 18	24	R3B2TFFA49 42	98
R3B1TF2A49 48	93	R3B1TFF79 18	71	R3B2PFF49 20	24	R3B2TFFA49 48	98
R3B1TF2B49 30	94	R3B1TFF79 20	71	R3B2PFF49 24	24	R3B2TFFB49 30	98
R3B1TF2B49 36	94	R3B1TFF79 24	71	R3B2PFF49 30	24	R3B2TFFB49 36	98
R3B1TF2B49 42	94	R3B1TFF79 30	71	R3B2PFF49 36	24	R3B2TFFB49 42	98
R3B1TF2B49 48	94	R3B1TFF79 36	71	R3B2PFF49 42	24	R3B2TFFB49 48	98
R3B1TF342 18	54	R3B1TFF79 42	71	R3B2PFF49 48	24	R3CRTT60	102
R3B1TF342 20	54	R3B1TFF79 48	71	R3B2PFF64 18	31	R3CRTT72	102
R3B1TF342 24	54	R3B1TFFA49 18	84	R3B2PFF64 20	31	R3CRTT84	102
R3B1TF342 30	54	R3B1TFFA49 20	84	R3B2PFF64 24	31	R3CRTT96	102
R3B1TF342 36	54	R3B1TFFA49 24	84	R3B2PFF64 30	31	R3FTCE104(F/T)(F/T)(F/T)	124
R3B1TF342 42	54	R3B1TFFA49 30	84	R3B2PFF64 36	31	R3FTCE108(F/T)(F/T)(F/T)	124
R3B1TF342 48	54	R3B1TFFA49 36	84	R3B2PFF64 42	31	R3FTCE120(F/T)(F/T)(F/T)	124
R3B1TF349 18	61	R3B1TFFA49 42	84	R3B2PFF64 48	31	R3FTCE21	124
R3B1TF349 20	61	R3B1TFFA49 48	84	R3B2PFF79 18	38	R3FTCE25	124
R3B1TF349 24	61	R3B1TFFB49 30	85	R3B2PFF79 20	38	R3FTCE37	124
R3B1TF349 30	61	R3B1TFFB49 36	85	R3B2PFF79 24	38	R3FTCF12118	121
R3B1TF349 36	61	R3B1TFFB49 42	85	R3B2PFF79 30	38	R3FTCF12120	121
R3B1TF349 42	61	R3B1TFFB49 48	85	R3B2PFF79 36	38	R3FTCF12124	121
R3B1TF349 48	61	R3B1TFL42 18	51	R3B2PFF79 42	38	R3FTCF12130	121
R3B1TF364 18	68	R3B1TFL42 20	51	R3B2PFF79 48	38	R3FTCF12136	121
R3B1TF364 20	68	R3B1TFL42 24	51	R3B2PFFA49 18	99	R3FTCF12142	121
R3B1TF364 24	68	R3B1TFL42 30	51	R3B2PFFA49 20	99	R3FTCF12148	121
R3B1TF364 30	68	R3B1TFL42 36	51	R3B2PFFA49 24	99	R3FTCF12518	122
R3B1TF364 36	68	R3B1TFL42 42	51	R3B2PFFA49 30	99	R3FTCF12520	122
R3B1TF364 42	68	R3B1TFL42 48	51	R3B2PFFA49 36	99	R3FTCF12524	122
R3B1TF364 48	68	R3B1TFL49 18	58	R3B2PFFA49 42	99	R3FTCF12530	122
R3B1TF379 18	75	R3B1TFL49 20	58	R3B2PFFA49 48	99	R3FTCF12536	122
R3B1TF379 20	75	R3B1TFL49 24	58	R3B2PFFB49 30	99	R3FTCF12542	122
R3B1TF379 24	75	R3B1TFL49 30	58	R3B2PFFB49 36	99	R3FTCF12548	122
R3B1TF379 30	75	R3B1TFL49 36	58	R3B2PFFB49 42	99	R3FTCF13718	123
R3B1TF379 36	75	R3B1TFL49 42	58	R3B2PFFB49 48	99	R3FTCF13720	123
R3B1TF379 42	75	R3B1TFL49 48	58	R3B2TFF42 18	50	R3FTCF13724	123
R3B1TF379 48	75	R3B1TFL64 18	65	R3B2TFF42 20	50	R3FTCF13730	123
R3B1TF3A49 18	96	R3B1TFL64 20	65	R3B2TFF42 24	50	R3FTCF13736	123
R3B1TF3A49 20	96	R3B1TFL64 24	65	R3B2TFF42 30	50	R3FTCF13742	123
R3B1TF3A49 24	96	R3B1TFL64 30	65	R3B2TFF42 36	50	R3FTCF13748	123
R3B1TF3A49 30	96	R3B1TFL64 36	65	R3B2TFF42 42	50	R3FTCF22118	121
R3B1TF3A49 36	96	R3B1TFL64 42	65	R3B2TFF42 48	50	R3FTCF22120	121
R3B1TF3A49 42	96	R3B1TFL64 48	65	R3B2TFF49 18	57	R3FTCF22124	121
R3B1TF3A49 48	96	R3B1TFL79 18	72	R3B2TFF49 20	57	R3FTCF22130	121
R3B1TF3B49 30	96	R3B1TFL79 20	72	R3B2TFF49 24	57	R3FTCF22136	121
R3B1TF3B49 36	96	R3B1TFL79 24	72	R3B2TFF49 30	57	R3FTCF22142	121
R3B1TF3B49 42	96	R3B1TFL79 30	72	R3B2TFF49 36	57	R3FTCF22148	121
R3B1TF3B49 48	96	R3B1TFL79 36	72	R3B2TFF49 42	57	R3FTCF22518	122
R3B1TFF42 18	50	R3B1TFL79 42	72	R3B2TFF49 48	57	R3FTCF22520	122
R3B1TFF42 20	50	R3B1TFL79 48	72	R3B2TFF64 18	64	R3FTCF22524	122
R3B1TFF42 24	50	R3B1TFLA49 18	87	R3B2TFF64 20	64	R3FTCF22530	122
R3B1TFF42 30	50	R3B1TFLA49 20	87	R3B2TFF64 24	64	R3FTCF22536	122
R3B1TFF42 36	50	R3B1TFLA49 24	87	R3B2TFF64 30	64	R3FTCF22542	122
R3B1TFF42 42	50	R3B1TFLA49 30	87	R3B2TFF64 36	64	R3FTCF22548	122
R3B1TFF42 48	50	R3B1TFLA49 36	87	R3B2TFF64 42	64	R3FTCF23718	123
R3B1TFF49 18	57	R3B1TFLA49 42	87	R3B2TFF64 48	64	R3FTCF23720	123
R3B1TFF49 20	57	R3B1TFLA49 48	87	R3B2TFF79 18	71	R3FTCF23724	123
R3B1TFF49 24	57	R3B1TFLB49 30	88	R3B2TFF79 20	71	R3FTCF23730	123

<i>pattern no.</i>	<i>page</i>	<i>pattern no.</i>	<i>page</i>	<i>pattern no.</i>	<i>page</i>	<i>pattern no.</i>	<i>page</i>
R3FTCF23736	123	R3FTCFL3748	123	R3SF21530	104	R3T08T	105
R3FTCF23742	123	R3FTCL104(F/T)(F/T)	124	R3SF21536	104	R3T15T	105
R3FTCF23748	123	R3FTCL108(F/T)(F/T)	124	R3SF21542	104	R3T34(F/T)	105
R3FTCF321 18	121	R3FTCL120(F/T)(F/T)	124	R3SF21548	104	R3T42(B)(F/T)	105
R3FTCF321 20	121	R3FTCL21	124	R3SF30818	103	R3T49(B)(F/T)	105
R3FTCF321 24	121	R3FTCL25	124	R3SF30820	103	R3T64(B)(F/T)	105
R3FTCF321 30	121	R3FTCL37	124	R3SF30824	103	R3T79(B)(F/T)	105
R3FTCF321 36	121	R3FTCS104(F/T)(F/T)	124	R3SF30830	103	R3X08	106
R3FTCF321 42	121	R3FTCS108(F/T)(F/T)	124	R3SF30836	103	R3X15	106
R3FTCF321 48	121	R3FTCS120(F/T)(F/T)	124	R3SF30842	103	R3X34	106
R3FTCF325 18	122	R3FTCS21	124	R3SF30848	103	R3X42(B)	106
R3FTCF325 20	122	R3FTCS25	124	R3SF315 18	104	R3X49(B)	106
R3FTCF325 24	122	R3FTCS37	124	R3SF315 20	104	R3X64(B)	106
R3FTCF325 30	122	R3FTCSM (Pair) for G3 only	125	R3SF315 24	104	R3X79(B)	106
R3FTCF325 36	122	R3FTCT104(F/T)	124	R3SF315 30	104	R5ZNNE (3 dividers)	431
R3FTCF325 42	122	R3FTCT108(F/T)	124	R3SF315 36	104	R917762	421
R3FTCF325 48	122	R3FTCT120(F/T)	124	R3SF315 42	104	R921655	421
R3FTCF337 18	123	R3FTCT21	124	R3SF315 48	104	R9TDCFM8430	222
R3FTCF337 20	123	R3FTCT25	124	R3SFF08 18	100	R9TDCFM9630	222
R3FTCF337 24	123	R3FTCT37	124	R3SFF08 20	100	RAMTB	408
R3FTCF337 30	123	R3FTCX104	124	R3SFF08 24	100	RAMTC24	408
R3FTCF337 36	123	R3FTCX108	124	R3SFF08 30	100	RAMTC30	408
R3FTCF337 42	123	R3FTCX120	124	R3SFF08 36	100	RAMTC36	408
R3FTCF337 48	123	R3FTCX21	124	R3SFF08 42	100	RAMTC42	408
R3FTCF2118	118	R3FTCX25	124	R3SFF08 48	100	RAMTC48	408
R3FTCF2120	118	R3FTCX37	124	R3SFF15 18	100	RAMTC54	408
R3FTCF2124	118	R3L08TT	105	R3SFF15 20	100	RAMTC60	408
R3FTCF2130	118	R3L15TT	105	R3SFF15 24	100	RAMTC66	408
R3FTCF2136	118	R3L34(F/T)(F/T)	105	R3SFF15 30	100	RAMTC72	408
R3FTCF2142	118	R3L42(B)(F/T)(F/T)	105	R3SFF15 36	100	RAMTCH24	408
R3FTCF2148	118	R3L49(B)(F/T)(F/T)	105	R3SFF15 42	100	RAMTCH30	408
R3FTCF2518	119	R3L64(B)(F/T)(F/T)	105	R3SFF15 48	100	RAMTCH36	408
R3FTCF2520	119	R3L79(B)(F/T)(F/T)	105	R3SFL0818	103	RAMTCH42	408
R3FTCF2524	119	R3R2SLV	107, 117	R3SFL0820	103	RAMTCH48	408
R3FTCF2530	119	R3S08TT	106	R3SFL0824	103	RAMTCH54	408
R3FTCF2536	119	R3S15TT	106	R3SFL0830	103	RAMTCH60	408
R3FTCF2542	119	R3S34(F/T)(F/T)	106	R3SFL0836	103	RAMTCH66	408
R3FTCF2548	119	R3S42(B)(F/T)(F/T)	106	R3SFL0842	103	RAMTCH72	408
R3FTCF3718	120	R3S49(B)(F/T)(F/T)	106	R3SFL0848	103	RAMTT	408
R3FTCF3720	120	R3S64(B)(F/T)(F/T)	106	R3SFL1518	104	RATDCFM(L/R)4830	221
R3FTCF3724	120	R3S79(B)(F/T)(F/T)	106	R3SFL1520	104	RATDCFM(L/R)4836	221
R3FTCF3730	120	R3SF10818	103	R3SFL1524	104	RATDCFM(L/R)5430	221
R3FTCF3736	120	R3SF10820	103	R3SFL1530	104	RATDCFM(L/R)5436	221
R3FTCF3742	120	R3SF10824	103	R3SFL1536	104	RATDCFM(L/R)6030	221
R3FTCF3748	120	R3SF10830	103	R3SFL1542	104	RATDCFM(L/R)6036	221
R3FTCFL2118	121	R3SF10836	103	R3SFL1548	104	RATDCFM(L/R)6630	221
R3FTCFL2120	121	R3SF10842	103	R3SLL0818	103	RATDCFM(L/R)6636	221
R3FTCFL2124	121	R3SF10848	103	R3SLL0820	103	RATDCFM(L/R)7230	221
R3FTCFL2130	121	R3SF11518	104	R3SLL0824	103	RATDCFM(L/R)7236	221
R3FTCFL2136	121	R3SF11520	104	R3SLL0830	103	RATDCFM(L/R)7830	221
R3FTCFL2142	121	R3SF11524	104	R3SLL0836	103	RATDCFM(L/R)7836	221
R3FTCFL2148	121	R3SF11530	104	R3SLL0842	103	RATDCFM(L/R)8430	221
R3FTCFL2518	122	R3SF11536	104	R3SLL0848	103	RATDCFM(L/R)8436	221
R3FTCFL2520	122	R3SF11542	104	R3SLL1518	104	RATDCPC(L/R)6030	219
R3FTCFL2524	122	R3SF11548	104	R3SLL1520	104	RATDCPC(L/R)6036	219
R3FTCFL2530	122	R3SF20818	103	R3SLL1524	104	RATDCPC(L/R)6630	219
R3FTCFL2536	122	R3SF20820	103	R3SLL1530	104	RATDCPC(L/R)6636	219
R3FTCFL2542	122	R3SF20824	103	R3SLL1536	104	RATDCPC(L/R)7230	219
R3FTCFL2548	122	R3SF20830	103	R3SLL1542	104	RATDCPC(L/R)7236	219
R3FTCFL3718	123	R3SF20836	103	R3SLL1548	104	RATDCPC(L/R)7830	219
R3FTCFL3720	123	R3SF20842	103	R3SMP	421	RATDCPC(L/R)7836	219
R3FTCFL3724	123	R3SF20848	103	R3SPABPT	115	RATDCPC(L/R)8430	219
R3FTCFL3730	123	R3SF21518	104	R3SPABTD	115	RATDCPC(L/R)8436	219
R3FTCFL3736	123	R3SF21520	104	R3SPABTT	115	RATDCST(L/R)6030	220
R3FTCFL3742	123	R3SF21524	104	R3SPABTW	115	RATDCST(L/R)6036	220



<i>pattern no.</i>	<i>page</i>	<i>pattern no.</i>	<i>page</i>	<i>pattern no.</i>	<i>page</i>	<i>pattern no.</i>	<i>page</i>
RATDCST(L/R)6630	220	RBDH4836	241	RC561DHB	311, 312	RC7213DHDH(L/R)	317
RATDCST(L/R)6636	220	RBDH4842	241	RC562DHB	311, 312	RC7213DHGH(L/R)	314, 316
RATDCST(L/R)7230	220	RBDH4848	241	RC562DHF	311, 312	RC7232DHB	313, 316
RATDCST(L/R)7236	220	RBDH48M(F/R)	241	RC563DHB	311, 312	RC7232DHDH	317
RATDCST(L/R)7830	220	RBDH52MR	243	RC563DHF	311, 312	RC7232DHEH(L/R)	315
RATDCST(L/R)7836	220	RBDH54M(F/R)	241	RC612C(L/R)	290, 293	RC7232DHFH	313, 316
RATDCST(L/R)8430	220	RBDH60M(F/R)	241	RC612D(L/R)	293	RC7232DHGH	314, 316
RATDCST(L/R)8436	220	RBDH64MR	243	RC612G(L/R)	291, 295	RC7233DHB	313, 316
RB24(M/H)(F/R)	239	RBDH66M(F/R)	241	RC612P(L/R)	292, 295	RC7233DHDH	317
RB30(M/H)(F/R)	239	RBDH72M(F/R)	241	RC613C(L/R)	290, 293	RC7233DHEH(L/R)	315, 317
RB3636	239	RBDH78M(F/R)	241	RC613D(L/R)	293	RC7233DHFH	313, 316
RB3642	239	RBDH84M(F/R)	241	RC613G(L/R)	291, 295	RC7233DHGH	314, 316
RB3648	239	RBDH90M(F/R)	241	RC613P(L/R)	292, 295	RC723M	308, 310
RB36(M/H)(F/R)	239	RBDH96M(F/R)	241	RC623M	307, 309	RC723N	308, 310
RB40MR	184	RBDP6030JK(A,B,W)	414	RC623N	307, 309	RC7262DHB	313, 316
RB4236	239	RBDP7230JK(A,B,W)	414	RC631B	290, 293	RC7262DHDH	317
RB4242	239	RBDP8430JK(A,B,W)	414	RC632B	290, 293	RC7262DHEH(L/R)	315, 317
RB4248	239	RBDP9630JK(A,B,W)	414	RC632C	290, 293	RC7262DHFH	313, 316
RB42(M/H)(F/R)	239	RBDW	422	RC632D	293	RC7262DHGH	314, 316
RB4836	239	RBF (Pair)	237	RC632E(L/R)	291, 294	RC7263DHB	313, 316
RB4842	239	RBPE(L/R)	422	RC632F	290, 294	RC7263DHDH	317
RB4848	239	RBPP (L/R)	237	RC632G	291, 295	RC7263DHEH(L/R)	315, 317
RB48(M/H)(F/R)	239	RBPR (Pair)	238	RC632H	291, 294	RC7263DHFH	313, 316
RB52MR	184	RBPS (L/R)	238	RC632I	295	RC7263DHGH	314, 316
RB54(M/H)(F/R)	239	RBR3624(A,B,W)(F,N)2	417	RC632P	292, 295	RC732B	296, 301
RB60(M/H)(F/R)	239	RBR3630(A,B,W)(F,N)2	417	RC633B	290, 293	RC732C	296, 301
RB64MR	184	RBR4224(A,B,W)(F,N)2	417	RC633C	290, 293	RC732D	305
RB66(M/H)(F/R)	239	RBR4230(A,B,W)(F,N)2	417	RC633D	293	RC732DHB	318, 322
RB72(M/H)(F/R)	239	RBR4824(A,B,W)(F,N)2	417	RC633E(L/R)	291, 294	RC732DHD	326
RB78(M/H)(F/R)	239	RBR4830(A,B,W)(F,N)2	417	RC633F	290, 294	RC732DHEH(L/R)	318, 322
RB84(M/H)(F/R)	239	RBSPP6030J(A,B,W)	413	RC633G	291, 295	RC732DHF	321, 325
RB90(M/H)(F/R)	239	RBSPP7230J(A,B,W)	413	RC633H	291, 294	RC732DHG	319, 323
RB96(M/H)(F/R)	239	RBSPP8430J(A,B,W)	413	RC633I	295	RC732DHK	320, 324
RBC18 (L/R)	236	RBSPP9630J(A,B,W)	413	RC633P	292, 295	RC732E(L/R)	297, 302
RBC24 (L/R)	236	RBWC24	238	RC661B	290, 293	RC732F	298, 303
RBCC	237	RBWC30	238	RC662B	290, 293	RC732G	299, 304
RBCCP (Pair)	237	RBWM	423	RC662C	290, 293	RC732H	300, 305
RBD361H	196	RBZ (A/B) (Pair)	237	RC662D	293	RC732I	306
RBD361V	196	RC412C(L/R)	286, 288	RC662E(L/R)	291, 294	RC732P	300, 306
RBD362H	196	RC413C(L/R)	286, 288	RC662F	290, 294	RC733B	296, 301
RBD362V	196	RC423M	307, 309	RC662G	291, 295	RC733C	296, 301
RBD421H	196	RC423N	307, 309	RC662H	291, 294	RC733D	305
RBD421V	196	RC431B	287, 288	RC662I	295	RC733DHB	318, 322
RBD422H	196	RC432B	287, 288	RC662P	292, 295	RC733DHD	326
RBD422V	196	RC432C	286, 288	RC663B	290, 293	RC733DHE(L/R)	318, 322
RBD481H	196	RC432D	288	RC663C	290, 293	RC733DHF	321, 325
RBD481V	196	RC432F	286, 289	RC663D	293	RC733DHG	319, 323
RBD482H	196	RC433B	287, 288	RC663E(L/R)	291, 294	RC733DHK	320, 324
RBD482V	196	RC433C	286, 288	RC663F	290, 294	RC733E(L/R)	297, 302
RBD541H	196	RC433D	288	RC663G	291, 295	RC733F	298, 303
RBD541V	196	RC433F	286, 289	RC663H	291, 294	RC733G	299, 304
RBD542H	196	RC461B	287, 288	RC663I	295	RC733H	300, 305
RBD542V	196	RC462B	287, 288	RC663P	292, 295	RC733I	306
RBDD	422	RC462C	286, 288	RC712C(L/R)	296, 301	RC733P	300, 306
RBDH24M(F/R)	241	RC462D	288	RC712DHG(L/R)	319, 323	RC762B	296, 301
RBDH30M(F/R)	241	RC462F	286, 289	RC712D(L/R)	305	RC762C	296, 301
RBDH3636	241	RC463B	287, 288	RC712G(L/R)	299, 304	RC762D	305
RBDH3642	241	RC463C	286, 288	RC712P(L/R)	300, 306	RC762DHB	318, 322
RBDH3648	241	RC463D	288	RC713C(L/R)	296, 301	RC762DHD	326
RBDH36M(F/R)	241	RC463F	286, 289	RC713DHG(L/R)	319, 323	RC762DHE(L/R)	318, 322
RBDH40MR	243	RC531DHB	311, 312	RC713D(L/R)	305	RC762DHF	321, 325
RBDH4236	241	RC532DHB	311, 312	RC713G(L/R)	299, 304	RC762DHG	319, 323
RBDH4242	241	RC532DHF	311, 312	RC713P(L/R)	300, 306	RC762DHK	320, 324
RBDH4248	241	RC533DHB	311, 312	RC7212DHDH(L/R)	317	RC762E(L/R)	297, 302
RBDH42M(F/R)	241	RC533DHF	311, 312	RC7212DHGH(L/R)	314, 316	RC762F	298, 303

<i>pattern no.</i>	<i>page</i>	<i>pattern no.</i>	<i>page</i>	<i>pattern no.</i>	<i>page</i>	<i>pattern no.</i>	<i>page</i>
RC762G	299, 304	RCA424822	144	RCAWF363611	181	RCD3L9624K(A,B,W)	418
RC762H	300, 305	RCA483611	143	RCAWF363612	181	RCD601	199
RC762I	306	RCA483612	144	RCAWF363621	181	RCD602	199
RC762P	300, 306	RCA483621	143	RCAWF363622	181	RCD661	199
RC763B	296, 301	RCA483622	144	RCAWF364211	181	RCD662	199
RC763C	296, 301	RCA484211	143	RCAWF364212	181	RCD6L7224K(A,B,W)	418
RC763D	305	RCA484212	144	RCAWF364221	181	RCD6L9624K(A,B,W)	418
RC763DHB	318, 322	RCA484221	143	RCAWF364222	181	RCD721	199
RC763DHD	326	RCA484222	144	RCAWF364811	181	RCD722	199
RC763DHE(L/R)	318, 322	RCA484811	143	RCAWF364812	181	RCD781	199
RC763DHF	321, 325	RCA484812	144	RCAWF364821	181	RCD782	199
RC763DHG	319, 323	RCA484821	143	RCAWF364822	181	RCD841	199
RC763DHK	320, 324	RCA484822	144	RCAWF423611	181	RCD842	199
RC763E(L/R)	297, 302	RCA(A/B/C/D/E/F/G)F363611	160	RCAWF423612	181	RCD901	199
RC763F	298, 303	RCA(A/B/C/D/E/F/G)F363612	160	RCAWF423621	181	RCD902	199
RC763G	299, 304	RCA(A/B/C/D/E/F/G)F363621	160	RCAWF423622	181	RCD961	199
RC763H	300, 305	RCA(A/B/C/D/E/F/G)F363622	160	RCAWF424211	181	RCD962	199
RC763I	306	RCA(A/B/C/D/E/F/G)F364211	160	RCAWF424212	181	RCDHB	247
RC763P	300, 306	RCA(A/B/C/D/E/F/G)F364212	160	RCAWF424221	181	RCDHB20T	247
RC832DHB	331	RCA(A/B/C/D/E/F/G)F364221	160	RCAWF424222	181	RCDHB24T	247
RC832DHEH(L/R)	329, 332	RCA(A/B/C/D/E/F/G)F364222	160	RCAWF424811	181	RCDHB30T	247
RC832DHF	327, 330	RCA(A/B/C/D/E/F/G)F364811	160	RCAWF424812	181	RCDHB40T	247
RC832DHG	327, 330	RCA(A/B/C/D/E/F/G)F364812	160	RCAWF424821	181	RCDP6024K(A,B,W)	418
RC832DHK	328, 331	RCA(A/B/C/D/E/F/G)F364821	160	RCAWF424822	181	RCDP7224K(A,B,W)	418
RC832DHO	328, 331	RCA(A/B/C/D/E/F/G)F364822	161	RCAWF483611	181	RCDP8424K(A,B,W)	418
RC833DHB	331	RCA(A/B/C/D/E/F/G)F423611	160	RCAWF483612	181	RCDP9624K(A,B,W)	418
RC833DHEH(L/R)	329, 332	RCA(A/B/C/D/E/F/G)F423612	160	RCAWF483621	181	RCE1021	197
RC833DHF	327, 330	RCA(A/B/C/D/E/F/G)F423621	160	RCAWF483622	181	RCE1022	197
RC833DHG	327, 330	RCA(A/B/C/D/E/F/G)F423622	160	RCAWF484211	181	RCE1081	197
RC833DHK	328, 331	RCA(A/B/C/D/E/F/G)F424211	160	RCAWF484212	181	RCE1082	197
RC833DHO	328, 331	RCA(A/B/C/D/E/F/G)F424212	160	RCAWF484221	181	RCE1BD6648D(L/R)	189
RC862DHB	331	RCA(A/B/C/D/E/F/G)F424221	160	RCAWF484222	181	RCE1BD6648S(L/R)	189
RC862DHEH(L/R)	329, 332	RCA(A/B/C/D/E/F/G)F424222	160	RCB	244	RCE1BD7248D(L/R)	189
RC862DHF	327, 330	RCA(A/B/C/D/E/F/G)F424811	160	RCB20T	244	RCE1BD7248S(L/R)	189
RC862DHG	327, 330	RCA(A/B/C/D/E/F/G)F424812	160	RCB24T	244	RCE1BD7848D(L/R)	189
RC862DHK	328, 331	RCA(A/B/C/D/E/F/G)F424821	160	RCB24X	245	RCE1BD7848S(L/R)	189
RC862DHO	328, 331	RCA(A/B/C/D/E/F/G)F424822	161	RCB28X	245	RCE1BD8448D(L/R)	189
RC863DHB	331	RCA(A/B/C/D/E/F/G)F483611	160	RCB30T	244	RCE1BD8448S(L/R)	189
RC863DHEH(L/R)	329, 332	RCA(A/B/C/D/E/F/G)F483612	160	RCB36X	245	RCE1CR24L	192
RC863DHG	327, 330	RCA(A/B/C/D/E/F/G)F483621	160	RCB40T	244	RCE1CR24N	192
RC863DHK	328, 331	RCA(A/B/C/D/E/F/G)F483622	160	RCBDH24X	248	RCE1CR24R	192
RC863DHO	328, 331	RCA(A/B/C/D/E/F/G)F484211	160	RCBDH28X	248	RCE1H4818	192
RCA363611	143	RCA(A/B/C/D/E/F/G)F484212	160	RCBDH36X	248	RCE1H4818P	192
RCA363612	144	RCA(A/B/C/D/E/F/G)F484221	160	RCCDLA23672	145	RCE1H6024	192
RCA363621	143	RCA(A/B/C/D/E/F/G)F484222	161	RCCDLA23678	145	RCE1H6024P	192
RCA363622	144	RCA(A/B/C/D/E/F/G)F484811	160	RCCDLA23684	145	RCE1L3636SSN	190
RCA364211	143	RCA(A/B/C/D/E/F/G)F484812	160	RCCDLA23696	145	RCE1L4242DSN	190
RCA364212	144	RCA(A/B/C/D/E/F/G)F484821	160	RCCDLA33672	145	RCE1L4242SDN	190
RCA364221	143	RCA(A/B/C/D/E/F/G)F484822	161	RCCDLA33678	145	RCE1L4242SSN	190
RCA364222	144	RCABT1417	420	RCCDLA33684	145	RCE1L4260SSN	191
RCA364811	143	RCABT2917	420	RCCDLA33696	145	RCE1L4266SSN	191
RCA364812	144	RCACR16	420	RCCDRA23672	145	RCE1L4272SSN	191
RCA364821	143	RCACR30	420	RCCDRA23678	145	RCE1L4278SSN	191
RCA364822	144	RCACR30H	420	RCCDRA23684	145	RCE1L4848DDN	190
RCA423611	143	RCACR36	420	RCCDRA23696	145	RCE1L4848DSN	190
RCA423612	144	RCACR36H	420	RCCDRA33672	145	RCE1L4848SDN	190
RCA423621	143	RCAS1620	420	RCCDRA33678	145	RCE1L4848SSN	190
RCA423622	144	RCAS1624	420	RCCDRA33684	145	RCE1L4860DSN	191
RCA424211	143	RCAS3015	420	RCCDRA33696	145	RCE1L4860SDN	191
RCA424212	144	RCAS3020	420	RCD1021	199	RCE1L4860SSN	191
RCA424221	143	RCAS3024	420	RCD1022	199	RCE1L4866DSN	191
RCA424222	144	RCAS3615	420	RCD1081	199	RCE1L4866SDN	191
RCA424811	143	RCAS3620	420	RCD1082	199	RCE1L4866SSN	191
RCA424812	144	RCAS3624	420	RCD3L6024K(A,B,W)	418	RCE1L4872DSN	191
RCA424821	143	RCASL	421	RCD3L8424K(A,B,W)	418	RCE1L4872SDN	191

<i>pattern no.</i>	<i>page</i>	<i>pattern no.</i>	<i>page</i>	<i>pattern no.</i>	<i>page</i>	<i>pattern no.</i>	<i>page</i>
RCE1L4872SSN	191	RCE961	197	RCFS6413C(L/R)W	341	RDDP9636JK(A,B,W)	414
RCE1L4878SSN	191	RCE962	197	RCFS6413Y(L/R)M	335	RDHMBD	274
RCE1L4884SSN	191	RCEAL223660	146	RCFS6413Y(L/R)W	341	RDHMGD	274
RCE1L6042SSN	191	RCEAL223672	146	RCFS6413Z(L/R)M	335	RDHMH7210	252
RCE1L6048DSN	191	RCEAL224260	146	RCFS6413Z(L/R)W	341	RDHMH7211	252
RCE1L6048SDN	191	RCEAL224272	146	RCFS6432V(L/R)M	336	RDHMH7212	252
RCE1L6048SSN	191	RCEAL224872	146	RCFS6432V(L/R)W	342	RDHMH7220	252
RCE1L6642SSN	191	RCEAL224884	146	RCFS6432W(L/R)M	336	RDHMH7222	252
RCE1L6648DSN	191	RCEAL224896	146	RCFS6432W(L/R)W	342	RDHMH7230	252
RCE1L6648SDN	191	RCEAR223660	146	RCFS6432X(L/R)M	336	RDHMH7240	252
RCE1L6648SSN	191	RCEAR223672	146	RCFS6432X(L/R)W	342	RDHMH7810	252
RCE1L7242SSN	191	RCEAR224260	146	RCFS6433V(L/R)M	336	RDHMH7811	252
RCE1L7248DSN	191	RCEAR224272	146	RCFS6433V(L/R)W	342	RDHMH7812	252
RCE1L7248SDN	191	RCEAR224872	146	RCFS6433W(L/R)M	336	RDHMH7813	252
RCE1L7248SSN	191	RCEAR224884	146	RCFS6433W(L/R)W	342	RDHMH7820	252
RCE1L7842SSN	191	RCEAR224896	146	RCFS6433X(L/R)M	336	RDHMH7822	252
RCE1L7848DSN	191	RCEEG1021	198	RCFS6433X(L/R)W	342	RDHMH7823	252
RCE1L8448SSN	191	RCEEG1022	198	RCFS6812C(L/R)M	337	RDHMH7830	252
RCE1R1212G	421	RCEEG1081	198	RCFS6812C(L/R)W	343	RDHMH7840	252
RCE1R2424N	188	RCEEG1082	198	RCFS6812Y(L/R)M	337	RDHMH8410	253
RCE1R2430N	188	RCEEG601	198	RCFS6812Y(L/R)W	343	RDHMH8411	252
RCE1R3024N	188	RCEEG602	198	RCFS6812Z(L/R)M	337	RDHMH8412	252
RCE1R3030N	188	RCEEG661	198	RCFS6812Z(L/R)W	343	RDHMH8413	252
RCE1R3624N	188	RCEEG662	198	RCFS6813C(L/R)M	337	RDHMH8414	252
RCE1R3630N	188	RCEEG721	198	RCFS6813C(L/R)W	343	RDHMH8420	253
RCE1R4224N	188	RCEEG722	198	RCFS6813Y(L/R)M	337	RDHMH8422	252
RCE1R4230N	188	RCEEG781	198	RCFS6813Y(L/R)W	343	RDHMH8423	252
RCE1R4824N	188	RCEEG782	198	RCFS6813Z(L/R)M	337	RDHMH8424	252
RCE1R4830N	188	RCEEG841	198	RCFS6813Z(L/R)W	343	RDHMH8430	253
RCE1R5424N	188	RCEEG842	198	RCFS6832V(L/R)M	338	RDHMH8440	253
RCE1R5430N	188	RCEEG901	198	RCFS6832V(L/R)W	344	RDHMH9010	253
RCE1R6024N	188	RCEEG902	198	RCFS6832W(L/R)M	338	RDHMH9011	252
RCE1R6030N	188	RCEEG961	198	RCFS6832W(L/R)W	344	RDHMH9012	252
RCE1R6624N	188	RCEEG962	198	RCFS6832X(L/R)M	338	RDHMH9013	252
RCE1R6630N	188	RCFS4912C(L/R)M	333	RCFS6832X(L/R)W	344	RDHMH9014	252
RCE1R7224N	188	RCFS4912C(L/R)W	339	RCFS6833V(L/R)M	338	RDHMH9020	253
RCE1R7230N	188	RCFS4912Y(L/R)M	333	RCFS6833V(L/R)W	344	RDHMH9022	252
RCE1R7824N	188	RCFS4912Y(L/R)W	339	RCFS6833W(L/R)M	338	RDHMH9023	252
RCE1R7830N	188	RCFS4912Z(L/R)M	333	RCFS6833W(L/R)W	344	RDHMH9024	252
RCE1R8424N	188	RCFS4912Z(L/R)W	339	RCFS6833X(L/R)M	338	RDHMH9030	253
RCE1R8430N	188	RCFS4913C(L/R)M	333	RCFS6833X(L/R)W	344	RDHMH9033	252
RCE1R9024N	188	RCFS4913C(L/R)W	339	RCOUNTWT	265, 266, 273	RDHMH9040	253
RCE1R9030N	188	RCFS4913Y(L/R)M	333	RCP41-(F/L/1/2/3)*	113	RDHMH9610	253
RCE1R9624N	188	RCFS4913Y(L/R)W	339	RCP56-(F/L/1/2/3)*	113	RDHMH9611	252
RCE1R9630N	188	RCFS4913Z(L/R)M	333	RCP71-(F/L/1/2/3)*	113	RDHMH9612	252
RCE1W362430N	193	RCFS4913Z(L/R)W	339	RCP78-(F/L/1/2/3)*	113	RDHMH9613	252
RCE1W363024N	193	RCFS4932V(L/R)M	333	RCS3L6024K(A,B,W)	416	RDHMH9614	252
RCE1W422430N	193	RCFS4932V(L/R)W	339	RCS3L7224K(A,B,W)	416	RDHMH9620	253
RCE1W423024N	193	RCFS4932W(L/R)M	334	RCS3L8424K(A,B,W)	416	RDHMH9622	252
RCE1W482430N	193	RCFS4932W(L/R)W	340	RCS3L9624K(A,B,W)	416	RDHMH9623	252
RCE1W483024N	193	RCFS4932X(L/R)M	334	RCS6L6024K(A,B,W)	416	RDHMH9624	252
RCE1W722430N	193	RCFS4932X(L/R)W	340	RCS6L7224K(A,B,W)	416	RDHMH9630	253
RCE1W723024N	193	RCFS4933V(L/R)M	333	RCS6L8424K(A,B,W)	416	RDHMH9633	252
RCE601	197	RCFS4933V(L/R)W	339	RCS6L9624K(A,B,W)	416	RDHMH9640	253
RCE602	197	RCFS4933W(L/R)M	334	RCS6P024K(A,B,W)	416	RDHMLD	274
RCE661	197	RCFS4933W(L/R)W	340	RCSP7224K(A,B,W)	416	RDHMR7210	250
RCE662	197	RCFS4933X(L/R)M	334	RCSP8424K(A,B,W)	416	RDHMR7211	250
RCE721	197	RCFS4933X(L/R)W	340	RCSP9624K(A,B,W)	416	RDHMR7212	250
RCE722	197	RCFS6412C(L/R)M	335	RDDP6030JK(A,B,W)	414	RDHMR7220	250
RCE781	197	RCFS6412C(L/R)W	341	RDDP6036JK(A,B,W)	414	RDHMR7222	250
RCE782	197	RCFS6412Y(L/R)M	335	RDDP7230JK(A,B,W)	414	RDHMR7230	250
RCE841	197	RCFS6412Y(L/R)W	341	RDDP7236JK(A,B,W)	414	RDHMR7240	250
RCE842	197	RCFS6412Z(L/R)M	335	RDDP8430JK(A,B,W)	414	RDHMR7810	250
RCE901	197	RCFS6412Z(L/R)W	341	RDDP8436JK(A,B,W)	414	RDHMR7811	250
RCE902	197	RCFS6413C(L/R)M	335	RDDP9630JK(A,B,W)	414	RDHMR7812	250

<i>pattern no.</i>	<i>page</i>	<i>pattern no.</i>	<i>page</i>	<i>pattern no.</i>	<i>page</i>	<i>pattern no.</i>	<i>page</i>
RDHMR7820	250	RDTAHW3142(L/R)	351	RDTSBWG156	345	RFTCWA2548	119
RDHMR7822	250	RDTAHW3156(L/R)	351	RDTSBWT142	345	RFTCWA3718	120
RDHMR7830	250	RDTAHW6142(L/R)	351	RDTSBWT156	345	RFTCWA3720	120
RDHMR7840	250	RDTAHW6156(L/R)	351	RDTSCGW142(L/R)	347	RFTCWA3724	120
RDHMR8410	250	RDTC3010	491	RDTSCGW156(L/R)	347	RFTCWA3730	120
RDHMR8411	250	RDTC3610	491	RDTSCWT142(L/R)	347	RFTCWA3736	120
RDHMR8412	250	RDTC6010	491	RDTSCWT156(L/R)	347	RFTCWA3742	120
RDHMR8414	250	RDTC7210	491	RDTSHWG142(L/R)	346	RFTCWA3748	120
RDHMR8420	250	RDTCO6010	491	RDTSHWG156(L/R)	346	RFTCWB2130	118
RDHMR8422	250	RDTCO7210	491	RDTSHWT142(L/R)	346	RFTCWB2136	118
RDHMR8423	250	RDTDBW3142	348	RDTSHWT156(L/R)	346	RFTCWB2142	118
RDHMR8430	250	RDTDBW3156	348	RE12F	240	RFTCWB2148	118
RDHMR8440	250	RDTDBW6142	348	RE15F	240	RFTCWB2530	119
RDHMR9010	250	RDTDBW6156	348	RE19F	240	RFTCWB2536	119
RDHMR9011	250	RDTDCCFM(L/R)5430	225	RE23F	240	RFTCWB2542	119
RDHMR9012	250	RDTDCCFM(L/R)5436	225	RE29F	240	RFTCWB2548	119
RDHMR9013	251	RDTDCCFM(L/R)6030	225	RE30	240	RFTCWB3730	120
RDHMR9014	250	RDTDCCFM(L/R)6036	225	RE36	240	RFTCWB3736	120
RDHMR9020	250	RDTDCCFM(L/R)6630	225	REBA6030	149	RFTCWB3742	120
RDHMR9022	251	RDTDCCFM(L/R)6636	225	REBA7242	149	RFTCWB3748	120
RDHMR9023	251	RDTDCCFM(L/R)7230	225	REBA7848	149	RFTCWS21S	125
RDHMR9024	251	RDTDCCFM(L/R)7236	225	REBA(A/B/C/D/E/F/G)A6030	166	RFTCWS25S	125
RDHMR9030	250	RDTDCCFM(L/R)7830	225	REBA(A/B/C/D/E/F/G)A7242	166	RFTCWS37S	125
RDHMR9040	250	RDTDCCFM(L/R)7836	225	REBA(A/B/C/D/E/F/G)A7848	166	RFTCWT (Pair)	125
RDHMR9610	250	RDTDCCFM(L/R)8430	225	REBAWA6030	185	RGAB421	409
RDHMR9611	251	RDTDCCFM(L/R)8436	225	REBAWA7242	185	RGAB481	409
RDHMR9612	251	RDTDCCPC(L/R)6630	223	REBAWA7848	185	RGAB541	409
RDHMR9613	251	RDTDCCPC(L/R)6636	223	REBH24	185	RGAB601	409
RDHMR9614	251	RDTDCCPC(L/R)7230	223	REBH30	185	RGAB661	409
RDHMR9620	250	RDTDCCPC(L/R)7236	223	REDH12F	242	RGAB721	409
RDHMR9622	251	RDTDCCPC(L/R)7830	223	REDH15F	242	RGAB781	409
RDHMR9623	251	RDTDCCPC(L/R)7836	223	REDH19F	242	RGAB841	409
RDHMR9624	251	RDTDCCPC(L/R)8430	223	REDH23F	242	RGAB901	409
RDHMR9630	250	RDTDCCPC(L/R)8436	223	REDH29F	242	RGAB961	409
RDHMR9633	251	RDTDCCPC(L/R)9030	223	REDH30	242	RCAF622	409
RDHMR9640	250	RDTDCCPC(L/R)9036	223	REDH36	242	RCAF623	409
RDHPM26	254	RDTDCCPC(L/R)9630	223	REDHBH124	243	RCAF682	409
RDHPM32	254	RDTDCCPC(L/R)9636	223	REDHBH130	243	RCAF683	409
RDHPM38	254	RDTDCCST(L/R)6630	224	RFDR30	431	RCAF742	409
RDHPM44	254	RDTDCCST(L/R)6636	224	RFDR36	431	RCAF743	409
RDHPM50	254	RDTDCCST(L/R)7230	224	RFDR42	431	RCAF802	409
RDHPM56	254	RDTDCCST(L/R)7236	224	RFDR48	431	RCAF803	409
RDHPM62	254	RDTDCCST(L/R)7830	224	RFDR60	431	RCAF862	409
RDHPM68	254	RDTDCCST(L/R)7836	224	RFDR72	431	RCAF863	409
RDHPM74	254	RDTDCCST(L/R)8430	224	RFDR84	431	RCAF922	409
RDSP6030J(A,B,W)	413	RDTDCCST(L/R)8436	224	RFDR96	431	RCAF923	409
RDSP6036J(A,B,W)	413	RDTDCCST(L/R)9030	224	RFTCC108	125	RCAF982	409
RDSP7230J(A,B,W)	413	RDTDCCST(L/R)9036	224	RFTCCCLIPS	125	RCAF983	409
RDSP7236J(A,B,W)	413	RDTDCCST(L/R)9630	224	RFTCDR (Pair)	125	RGAL431	411
RDSP8430J(A,B,W)	413	RDTDCCST(L/R)9636	224	RFTCG1 (Pair)	125	RGAL432	411
RDSP8436J(A,B,W)	413	RDTDCCW3142	350	RFTCSM (Pair) for G2 only	125	RGAL433	411
RDSP9630J(A,B,W)	413	RDTDCCW3156	350	RFTCSPACE	125	RGAL491	411
RDSP9636J(A,B,W)	413	RDTDCCW6142	350	RFTCWA2118	118	RGAL492	411
RDTAGG3142(L/R)	350	RDTDCCW6156	350	RFTCWA2120	118	RGAL493	411
RDTAGG3156(L/R)	350	RDTDHW3142	349	RFTCWA2124	118	RGAL551	411
RDTAGG6142(L/R)	350	RDTDHW3156	349	RFTCWA2130	118	RGAL552	411
RDTAGG6156(L/R)	350	RDTDHW6142	349	RFTCWA2136	118	RGAL553	411
RDTAGW3142(L/R)	350	RDTDHW6156	349	RFTCWA2142	118	RGAL611	411
RDTAGW3156(L/R)	350	RDTE22120	424	RFTCWA2148	118	RGAL612	411
RDTAGW6142(L/R)	350	RDTE2272	424	RFTCWA2518	119	RGAL613	411
RDTAGW6156(L/R)	350	RDTE22H	424	RFTCWA2520	119	RGAL671	411
RDTAHC3142(L/R)	351	RDTEA	424	RFTCWA2524	119	RGAL672	411
RDTAHC3156(L/R)	351	RDTGB	424	RFTCWA2530	119	RGAL673	411
RDTAHC6142(L/R)	351	RDTGC	424	RFTCWA2536	119	RGAL731	411
RDTAHC6156(L/R)	351	RDTSBWG142	345	RFTCWA2542	119	RGAL732	411

<i>pattern no.</i>	<i>page</i>	<i>pattern no.</i>	<i>page</i>	<i>pattern no.</i>	<i>page</i>	<i>pattern no.</i>	<i>page</i>
RGAL733	411	RJBU30	423	RM9A4836	148	RMDA(A/B/C/D/E/F/G)F7836	164
RGAL791	411	RJBU36	423	RM9A8430	148	RMDA(A/B/C/D/E/F/G)F8430	164
RGAL792	411	RJBU42	423	RM9A9630	148	RMDA(A/B/C/D/E/F/G)F8436	164
RGAL793	411	RJBU48	423	RM9A(A/B/C/D/E/F/G)F4230	165	RMDA(A/B/C/D/E/F/G)F9030	164
RGAL851	411	RJBU54	423	RM9A(A/B/C/D/E/F/G)F4836	165	RMDA(A/B/C/D/E/F/G)F9036	164
RGAL852	411	RJBU60	423	RM9A(A/B/C/D/E/F/G)F8430	165	RMDA(A/B/C/D/E/F/G)F9630	164
RGAL853	411	RJBU66	423	RM9A(A/B/C/D/E/F/G)F9630	165	RMDA(A/B/C/D/E/F/G)F9636	164
RGAL911	411	RJBU72	423	RM9AWF4230	183	RMDAWF4221	182
RGAL912	411	RJBW24	423	RM9AWF8430	183	RMDAWF4230	182
RGAL913	411	RJBW30	423	RM9AWF9630	183	RMDAWF4236	182
RGAL971	411	RJBW36	423	RMB(A)7230	150	RMDAWF4830	182
RGAL972	411	RJBW42	423	RMB(A)7236	150	RMDAWF4836	182
RGAL973	411	RJBW48	423	RMB(A)8430	150	RMDAWF5025	182
RGAR431	410	RJBW54	423	RMB(A)8436	150	RMDAWF5430	182
RGAR432	410	RJBW60	423	RMB(A)9630	150	RMDAWF5436	182
RGAR433	410	RJBW66	423	RMB(A)9636	150	RMDAWF6030	182
RGAR491	410	RJBW72	423	RMB(A/B/C/D/E/F/G)A7230	166	RMDAWF6036	182
RGAR492	410	RKA 363611	139	RMB(A/B/C/D/E/F/G)A7236	166	RMDAWF6630	182
RGAR493	410	RKA 363612	139	RMB(A/B/C/D/E/F/G)A8430	166	RMDAWF6636	182
RGAR551	410	RKA 363621	140	RMB(A/B/C/D/E/F/G)A8436	166	RMDAWF7230	182
RGAR552	410	RKA 363622	139	RMB(A/B/C/D/E/F/G)A9630	166	RMDAWF7236	182
RGAR553	410	RKA 364211	139	RMB(A/B/C/D/E/F/G)A9636	166	RMDAWF7830	182
RGAR611	410	RKA 364212	139	RMBAWA7230	184	RMDAWF7836	182
RGAR612	410	RKA 364221	140	RMBAWA7236	184	RMDAWF8430	182
RGAR613	410	RKA 364222	139	RMBAWA8430	184	RMDAWF8436	182
RGAR671	410	RKA 364811	139	RMBAWA8436	184	RMDAWF9030	182
RGAR672	410	RKA 364812	139	RMBAWA9630	184	RMDAWF9036	182
RGAR673	410	RKA 364821	140	RMBAWA9636	184	RMDAWF9630	182
RGAR731	410	RKA 364822	139	RMDA4221	147	RMDAWF9636	182
RGAR732	410	RKA 423611	139	RMDA4230	147	RMPA4230	148
RGAR733	410	RKA 423612	139	RMDA4236	147	RMPA4836	148
RGAR791	410	RKA 423621	140	RMDA4830	147	RMPA8430	149
RGAR792	410	RKA 423622	139	RMDA4836	147	RMPA9630	149
RGAR793	410	RKA 424211	139	RMDA5025	147	RMPA(A/B/C/D/E/F/G)F4230	165
RGAR851	410	RKA 424212	139	RMDA5430	147	RMPA(A/B/C/D/E/F/G)F4836	165
RGAR852	410	RKA 424221	140	RMDA5436	147	RMPA(A/B/C/D/E/F/G)F8430	165
RGAR853	410	RKA 424222	139	RMDA6030	147	RMPA(A/B/C/D/E/F/G)F9630	165
RGAR911	410	RKA 424811	139	RMDA6036	147	RMPAWF4230	183
RGAR912	410	RKA 424812	139	RMDA6630	147	RMPAWF8430	183
RGAR913	410	RKA 424821	140	RMDA6636	147	RMPAWF9630	183
RGAR971	410	RKA 424822	139	RMDA7230	147	RMPU	280
RGAR972	410	RKA 483611	139	RMDA7236	147	RMSCB	236
RGAR973	410	RKA 483612	139	RMDA7830	147	RO1-GB	396
RGMD6	133	RKA 483621	140	RMDA7836	147	RO1-HP12	391, 393, 394
RGMD8	133	RKA 483622	139	RMDA8430	147	RO1-HP15	391, 393, 394
RCMDE	133	RKA 484211	139	RMDA8436	147	RO1-HP6	391, 393, 394
RGS60	409	RKA 484212	139	RMDA9030	147	RO1-HP9	391, 393, 394
RGS66	409	RKA 484221	140	RMDA9036	147	RO1-PULL	396
RGS72	409	RKA 484222	139	RMDA9630	147	RO1-RCB	395
RGS78	409	RKA 484811	139	RMDA9636	147	RO1-RPB	395
RGS84	409	RKA 484812	139	RMDA(A/B/C/D/E/F/G)F4221	164	RO1-WMF2	396
RGS90	409	RKA 484821	140	RMDA(A/B/C/D/E/F/G)F4230	164	RO1-WMF3	396
RGS96	409	RKA 484822	139	RMDA(A/B/C/D/E/F/G)F4236	164	RO1-WMF4	396
RCTLA636	412	RKBA1020	420	RMDA(A/B/C/D/E/F/G)F4830	164	RO3-M24	390
RCTRA636	412	RKBA1022	420	RMDA(A/B/C/D/E/F/G)F4836	164	RO3-M30	390
RHSCN15	117	RKT31	420	RMDA(A/B/C/D/E/F/G)F5025	164	RO3-M36	390
RHSCN250	117	RLCCT301	285	RMDA(A/B/C/D/E/F/G)F5430	164	RO3-M42	390
RHSCN70	117	RLCCT361	285	RMDA(A/B/C/D/E/F/G)F5436	164	RO3-M48	390
RIB24T	244	RLCCT601	285	RMDA(A/B/C/D/E/F/G)F6030	164	RO3-M60	390, 391
RIB28X	245	RLCCT721	285	RMDA(A/B/C/D/E/F/G)F6036	164	RO3-M66	390, 391
RIB32X	245	RM111J	265, 266	RMDA(A/B/C/D/E/F/G)F6630	164	RO3-M72	390, 391
RIBDH24T	247	RM112J	265, 266	RMDA(A/B/C/D/E/F/G)F6636	164	RO3-N24	392
RIBDH28X	248	RM212J	265, 266	RMDA(A/B/C/D/E/F/G)F7230	164	RO3-N30	392
RIBDH32X	248	RM212K	265, 266	RMDA(A/B/C/D/E/F/G)F7236	164	RO3-N36	392
RJBU24	423	RM9A4230	148	RMDA(A/B/C/D/E/F/G)F7830	164	RO3-N42	392

<i>pattern no.</i>	<i>page</i>	<i>pattern no.</i>	<i>page</i>	<i>pattern no.</i>	<i>page</i>	<i>pattern no.</i>	<i>page</i>
RO3-N48	392	ROBF72S1DH	369	ROCCGSH961	375	ROCHDHP421	385
RO3-N60	392	ROBF72S1()	358	ROCGHCDHP301	386	ROCHDHP481	385
RO3-N66	392	ROBF84S0DH	369	ROCGHCDHP361	386	ROCHDHP541	385
RO3-N72	392	ROBF84S0()	358	ROCGHCDHP421	386	ROCHDHP601	385
RO3-ON30	394	ROBF84S1DH	369	ROCGHCDHP481	386	ROCHDHP661	385
RO3-ON36	394	ROBF84S1()	358	ROCGHCDHP541	386	ROCHDHP721	385
RO3-ON42	394	ROBF96S0DH	369	ROCGHCDHP601	386	ROCHDHP781	385
RO3-ON48	394	ROBF96S0()	358	ROCGHCDHP661	386	ROCHDHP841	385
RO3-ON60	394	ROBF96S1DH	369	ROCGHCDHP721	386	ROCHDHP901	385
RO3-ON72	394	ROBF96S1()	358	ROCGHCDHP781	386	ROCHDHP961	385
RO3-VP	391, 394	ROBH60T0DH	368	ROCGHCDHP841	386	ROCHODHP601	388
ROAF60S0DH	367	ROBH60T0()	358	ROCGHCDHP901	386	ROCHODHP661	388
ROAF60S0()	357	ROBH60T1DH	368	ROCGHCDHP961	386	ROCHODHP721	388
ROAF60S1DH	367	ROBH60T1()	358	ROCGHCSHP301	377	ROCHODHP781	388
ROAF60S1()	357	ROBH72T0DH	368	ROCGHCSHP361	377	ROCHODHP841	388
ROAF72S0DH	367	ROBH72T0()	358	ROCGHCSHP421	377	ROCHODHP901	388
ROAF72S0()	357	ROBH72T1DH	368	ROCGHCSHP481	377	ROCHODHP961	388
ROAF72S1DH	367	ROBH72T1()	358	ROCGHCSHP541	377	ROCHOCSP601	378
ROAF72S1()	357	ROBH90T0DH	368	ROCGHCSHP601	377	ROCHOCSP661	378
ROAF84S0DH	367	ROBH90T0()	358	ROCGHCSHP661	377	ROCHOCSP721	378
ROAF84S0()	357	ROBH90T1DH	368	ROCGHCSHP721	377	ROCHOCSP781	378
ROAF84S1DH	367	ROBH90T1()	358	ROCGHCSHP781	377	ROCHOCSP841	378
ROAF84S1()	357	ROBH96T0DH	368	ROCGHCSHP841	377	ROCHOCSP901	378
ROAF96S0DH	367	ROBH96T0()	358	ROCGHCSHP901	377	ROCHOCSP961	378
ROAF96S0()	357	ROBH96T1DH	368	ROCGHCSHP961	377	ROCHSHP301	376
ROAF96S1DH	367	ROBH96T1()	358	ROCGHOC DHP601	389	ROCHSHP361	376
ROAF96S1()	357	ROBO60T0DH	368	ROCGHOC DHP661	389	ROCHSHP421	376
ROAH60T0DH	366	ROBO60T0()	358	ROCGHOC DHP721	389	ROCHSHP481	376
ROAH60T0()	357	ROBO60T1DH	368	ROCGHOC DHP781	389	ROCHSHP541	376
ROAH60T1DH	366	ROBO60T1()	358	ROCGHOC DHP841	389	ROCHSHP601	376
ROAH60T1()	357	ROBO72T0DH	368	ROCGHOC DHP901	389	ROCHSHP661	376
ROAH72T0DH	366	ROBO72T0()	358	ROCGHOC DHP961	389	ROCHSHP721	376
ROAH72T0()	357	ROBO72T1DH	368	ROCGHOC SHP601	379	ROCHSHP781	376
ROAH72T1DH	366	ROBO72T1()	358	ROCGHOC SHP661	379	ROCHSHP841	376
ROAH72T1()	357	ROBO90T0DH	368	ROCGHOC SHP721	379	ROCHSHP901	376
ROAH90T0DH	366	ROBO90T0()	358	ROCGHOC SHP781	379	ROCHSHP961	376
ROAH90T0()	357	ROBO90T1DH	368	ROCGHOC SHP841	379	ROCOCDHP301	387
ROAH90T1DH	366	ROBO90T1()	358	ROCGHOC SHP901	379	ROCOCDHP361	387
ROAH90T1()	357	ROBO96T0DH	368	ROCGHOC SHP961	379	ROCOCDHP421	387
ROAH96T0DH	366	ROBO96T0()	358	ROCHCDHP301	385	ROCOCDHP481	387
ROAH96T0()	357	ROBO96T1DH	368	ROCHCDHP361	385	ROCOCDHP541	387
ROAH96T1DH	366	ROBO96T1()	358	ROCHCDHP421	385	ROCOCDHP601	387
ROAH96T1()	357	ROCCGDHP301	387	ROCHCDHP481	385	ROCOCDHP661	387
ROAO60T0DH	366	ROCCGDHP361	387	ROCHCDHP541	385	ROCOCDHP721	387
ROAO60T0()	357	ROCCGDHP421	387	ROCHCDHP601	385	ROCOCDHP781	387
ROAO60T1DH	366	ROCCGDHP481	387	ROCHCDHP661	385	ROCOCDHP841	387
ROAO60T1()	357	ROCCGDHP541	387	ROCHCDHP721	385	ROCOCDHP901	387
ROAO72T0DH	366	ROCCGDHP601	387	ROCHCDHP781	385	ROCOCDHP961	387
ROAO72T0()	357	ROCCGDHP661	387	ROCHCDHP841	385	ROCOCSHP301	375
ROAO72T1DH	366	ROCCGDHP721	387	ROCHCDHP901	385	ROCOCSHP361	375
ROAO72T1()	357	ROCCGDHP781	387	ROCHCDHP961	385	ROCOCSHP421	375
ROAO90T0DH	366	ROCCGDHP841	387	ROCHCSHP301	376	ROCOCSHP481	375
ROAO90T0()	357	ROCCGDHP901	387	ROCHCSHP361	376	ROCOCSHP541	375
ROAO90T1DH	366	ROCCGDHP961	387	ROCHCSHP421	376	ROCOCSHP601	375
ROAO90T1()	357	ROCCGSH301	375	ROCHCSHP481	376	ROCOCSHP661	375
ROAO96T0DH	366	ROCCGSH361	375	ROCHCSHP541	376	ROCOCSHP721	375
ROAO96T0()	357	ROCCGSH421	375	ROCHCSHP601	376	ROCOCSHP781	375
ROAO96T1DH	366	ROCCGSH481	375	ROCHCSHP661	376	ROCOCSHP841	375
ROAO96T1()	357	ROCCGSH541	375	ROCHCSHP721	376	ROCOCSHP901	375
ROBF60S0DH	369	ROCCGSH601	375	ROCHCSHP781	376	ROCOCSHP961	375
ROBF60S0()	358	ROCCGSH661	375	ROCHCSHP841	376	ROHDR30	431
ROBF60S1DH	369	ROCCGSH721	375	ROCHCSHP901	376	ROHDR36	431
ROBF60S1()	358	ROCCGSH781	375	ROCHCSHP961	376	ROHDR42	431
ROBF72S0DH	369	ROCCGSH841	375	ROCHDHP301	385	ROHDR48	431
ROBF72S0()	358	ROCCGSH901	375	ROCHDHP361	385	ROHDR60	431

<i>pattern no.</i>	<i>page</i>	<i>pattern no.</i>	<i>page</i>	<i>pattern no.</i>	<i>page</i>	<i>pattern no.</i>	<i>page</i>
ROHDR72	431	ROMDHMTF184RN	427	ROMGCHDHP361	381	ROMHDHP301	380
ROHDR90	431	ROMDHMTF184RR	428	ROMGCHDHP421	381	ROMHDHP361	380
ROHDR96	431	ROMDHMTF190RB	427	ROMGCHDHP481	381	ROMHDHP421	380
ROMCGDHP301	382	ROMDHMTF190RL	427	ROMGCHDHP541	381	ROMHDHP481	380
ROMCGDHP361	382	ROMDHMTF190RN	427	ROMGCHDHP601	381	ROMHDHP541	380
ROMCGDHP421	382	ROMDHMTF190RR	428	ROMGCHDHP661	381	ROMHDHP601	380
ROMCGDHP481	382	ROMDHMTF196RB	427	ROMGCHDHP721	381	ROMHDHP661	380
ROMCGDHP541	382	ROMDHMTF196RL	427	ROMGCHDHP781	381	ROMHDHP721	380
ROMCGDHP601	382	ROMDHMTF196RN	427	ROMGCHDHP841	381	ROMHDHP781	380
ROMCGDHP661	382	ROMDHMTF196RR	428	ROMGCHDHP901	381	ROMHDHP841	380
ROMCGDHP721	382	ROMDHMTF130RB	429	ROMGCHDHP961	381	ROMHDHP901	380
ROMCGDHP781	382	ROMDHMTF130RL	429	ROMGCHSHP301	372	ROMHDHP961	380
ROMCGDHP841	382	ROMDHMTF130RN	429	ROMGCHSHP361	372	ROMHOCDHP601	383
ROMCGDHP901	382	ROMDHMTF130RR	430	ROMGCHSHP421	372	ROMHOCDHP661	383
ROMCGDHP961	382	ROMDHMTF136RB	429	ROMGCHSHP481	372	ROMHOCDHP721	383
ROMCGSHP301	370	ROMDHMTF136RL	429	ROMGCHSHP541	372	ROMHOCDHP781	383
ROMCGSHP361	370	ROMDHMTF136RN	429	ROMGCHSHP601	372	ROMHOCDHP841	383
ROMCGSHP421	370	ROMDHMTF136RR	430	ROMGCHSHP661	372	ROMHOCDHP901	383
ROMCGSHP481	370	ROMDHMTF142RB	429	ROMGCHSHP721	372	ROMHOCDHP961	383
ROMCGSHP541	370	ROMDHMTF142RL	429	ROMGCHSHP781	372	ROMHOCDSHP601	373
ROMCGSHP601	370	ROMDHMTF142RN	429	ROMGCHSHP841	372	ROMHOCDSHP661	373
ROMCGSHP661	370	ROMDHMTF142RR	430	ROMGCHSHP901	372	ROMHOCDSHP721	373
ROMCGSHP721	370	ROMDHMTF148RB	429	ROMGCHSHP961	372	ROMHOCDSHP781	373
ROMCGSHP781	370	ROMDHMTF148RL	429	ROMCHOCDHP601	384	ROMHOCDSHP841	373
ROMCGSHP841	370	ROMDHMTF148RN	429	ROMCHOCDHP661	384	ROMHOCDSHP901	373
ROMCGSHP901	370	ROMDHMTF148RR	430	ROMCHOCDHP721	384	ROMHOCDSHP961	373
ROMCGSHP961	370	ROMDHMTF154RB	429	ROMCHOCDHP781	384	ROMHSHP301	371
ROMDHMTF130RB	427	ROMDHMTF154RL	429	ROMCHOCDHP841	384	ROMHSHP361	371
ROMDHMTF130RL	427	ROMDHMTF154RN	429	ROMCHOCDHP901	384	ROMHSHP421	371
ROMDHMTF130RN	427	ROMDHMTF154RR	430	ROMCHOCDHP961	384	ROMHSHP481	371
ROMDHMTF130RR	428	ROMDHMTF160RB	429	ROMHOCSHP601	374	ROMHSHP541	371
ROMDHMTF136RB	427	ROMDHMTF160RL	429	ROMHOCSHP661	374	ROMHSHP601	371
ROMDHMTF136RL	427	ROMDHMTF160RN	429	ROMHOCSHP721	374	ROMHSHP661	371
ROMDHMTF136RN	427	ROMDHMTF160RR	430	ROMHOCSHP781	374	ROMHSHP721	371
ROMDHMTF136RR	428	ROMDHMTF166RB	429	ROMHOCSHP841	374	ROMHSHP781	371
ROMDHMTF142RB	427	ROMDHMTF166RL	429	ROMHOCSHP901	374	ROMHSHP841	371
ROMDHMTF142RL	427	ROMDHMTF166RN	429	ROMHOCSHP961	374	ROMHSHP901	371
ROMDHMTF142RN	427	ROMDHMTF166RR	430	ROMH30S0()	352	ROMHSHP961	371
ROMDHMTF142RR	428	ROMDHMTF172RB	429	ROMH36S0()	352	ROMO30S0()	352
ROMDHMTF148RB	427	ROMDHMTF172RL	429	ROMH60S0()	352	ROMO36S0()	352
ROMDHMTF148RL	427	ROMDHMTF172RN	429	ROMH72S0()	352	ROMO42S0()	352
ROMDHMTF148RN	427	ROMDHMTF172RR	430	ROMHCDHP301	380	ROMO48S0()	352
ROMDHMTF148RR	428	ROMDHMTF178RB	429	ROMHCDHP361	380	ROMO60S0()	352
ROMDHMTF154RB	427	ROMDHMTF178RL	429	ROMHCDHP421	380	ROMO72S0()	352
ROMDHMTF154RL	427	ROMDHMTF178RN	429	ROMHCDHP481	380	ROMOCDHP301	382
ROMDHMTF154RN	427	ROMDHMTF178RR	430	ROMHCDHP541	380	ROMOCDHP361	382
ROMDHMTF154RR	428	ROMDHMTF184RB	429	ROMHCDHP601	380	ROMOCDHP421	382
ROMDHMTF160RB	427	ROMDHMTF184RL	429	ROMHCDHP661	380	ROMOCDHP481	382
ROMDHMTF160RL	427	ROMDHMTF184RN	429	ROMHCDHP721	380	ROMOCDHP541	382
ROMDHMTF160RN	427	ROMDHMTF184RR	430	ROMHCDHP781	380	ROMOCDHP601	382
ROMDHMTF160RR	428	ROMDHMTF190RB	429	ROMHCDHP841	380	ROMOCDHP661	382
ROMDHMTF166RB	427	ROMDHMTF190RL	429	ROMHCDHP901	380	ROMOCDHP721	382
ROMDHMTF166RL	427	ROMDHMTF190RN	429	ROMHCDHP961	380	ROMOCDHP781	382
ROMDHMTF166RN	427	ROMDHMTF190RR	430	ROMHCSHP301	371	ROMOCDHP841	382
ROMDHMTF166RR	428	ROMDHMTF196RB	429	ROMHCSHP361	371	ROMOCDHP901	382
ROMDHMTF172RB	427	ROMDHMTF196RL	429	ROMHCSHP421	371	ROMOCDHP961	382
ROMDHMTF172RL	427	ROMDHMTF196RN	429	ROMHCSHP481	371	ROMOCSHP301	370
ROMDHMTF172RN	427	ROMDHMTF196RR	430	ROMHCSHP541	371	ROMOCSHP361	370
ROMDHMTF172RR	428	ROMF30S0()	352	ROMHCSHP601	371	ROMOCSHP421	370
ROMDHMTF178RB	427	ROMF36S0()	352	ROMHCSHP661	371	ROMOCSHP481	370
ROMDHMTF178RL	427	ROMF42S0()	352	ROMHCSHP721	371	ROMOCSHP541	370
ROMDHMTF178RN	427	ROMF48S0()	352	ROMHCSHP781	371	ROMOCSHP601	370
ROMDHMTF178RR	428	ROMF60S0()	352	ROMHCSHP841	371	ROMOCSHP661	370
ROMDHMTF184RB	427	ROMF72S0()	352	ROMHCSHP901	371	ROMOCSHP721	370
ROMDHMTF184RL	427	ROMGCHDHP301	381	ROMHCSHP961	371	ROMOCSHP781	370

<i>pattern no.</i>	<i>page</i>	<i>pattern no.</i>	<i>page</i>	<i>pattern no.</i>	<i>page</i>	<i>pattern no.</i>	<i>page</i>
ROMOCSP841	370	ROWH90S1DH	363	RP192R	275, 276	RPAB16	265, 266
ROMOCSP901	370	ROWH90S1()	355	RP193J	268, 270	RPAB19	265, 266
ROMOCSP961	370	ROWH90T0DH	364	RP193K	268, 270	RPAB30	265, 266
ROPF30S0J	354	ROWH90T0()	355	RP211J	255, 258	RPAB36	265, 266
ROPF36S0J	354	ROWH90T1DH	364	RP211K	255, 258	RPAD	420
ROPF42S0J	354	ROWH90T1()	355	RP211L(L/R)	261, 263	RPADSS	425
ROPF48S0J	354	ROWH96S0DH	363	RP211M	261, 263	RAHFB16	425
ROPF60S0J	354	ROWH96S0()	355	RP212J	255, 258	RAHFB30	425
ROPF72S0J	354	ROWH96S1DH	363	RP212K	255, 258	RAHFB36	425
ROPF84S0J	354	ROWH96S1()	355	RP212L(L/R)	261, 263	RAHFM162	425
ROPF96S0J	354	ROWH96T0DH	364	RP212M	261, 263	RAHFM30	425
ROPH30S0()	353	ROWH96T0()	355	RP213J	255, 258	RAHFM36	425
ROPH36S0()	353	ROWH96T1DH	364	RP213K	255, 258	RPAPT	426
ROPH60S0()	353	ROWH96T1()	355	RP213L(L/R)	261, 263	RPB211J	256, 259
ROPH60T0()	353	ROWO60S0DH	361	RP213M	261, 263	RPB211K	256, 259
ROPH72S0()	353	ROWO60S0()	355	RP221J	257, 260	RPB211L(L/R)	262, 264
ROPH72T0()	353	ROWO60S1DH	361	RP221K	257, 260	RPB211M	262, 264
ROPH90S0()	353	ROWO60S1()	355	RP222J	257, 260	RPB212J	256, 259
ROPH90T0()	353	ROWO60T0DH	362	RP222K	257, 260	RPB212K	256, 259
ROPH96S0()	353	ROWO60T0()	355	RP223J	257, 260	RPB212L(L/R)	262, 264
ROPH96T0()	353	ROWO60T1DH	362	RP223K	257, 260	RPB212M	262, 264
ROPO30S0()	353	ROWO60T1()	355	RP231K	255, 258	RPB213J	256, 259
ROPO36S0()	353	ROWO72S0DH	361	RP231L	261, 263	RPB213K	256, 259
ROPO42S0()	353	ROWO72S0()	355	RP231M	261, 263	RPB213L(L/R)	262, 264
ROPO48S0()	353	ROWO72S1DH	361	RP232K	255, 258	RPB213M	262, 264
ROPO60S0()	353	ROWO72S1()	355	RP232L	261, 263	RPB231K	256, 259
ROPO60T0()	353	ROWO72T0DH	362	RP232M	261, 263	RPB231L	262, 264
ROPO72S0()	353	ROWO72T0()	355	RP261K	255, 258	RPB231M	262, 264
ROPO72T0()	353	ROWO72T1DH	362	RP261L	261, 263	RPB232K	256, 259
ROPO90S0()	353	ROWO72T1()	355	RP261M	261, 263	RPB232L	262, 264
ROPO90T0()	353	ROWO90S0DH	361	RP262K	255, 258	RPB232M	262, 264
ROPO96S0()	353	ROWO90S0()	355	RP262L	261, 263	RPB261K	256, 259
ROPO96T0()	353	ROWO90S1DH	361	RP262M	261, 263	RPB261L	262, 264
ROPS30S0NN	354	ROWO90S1()	355	RP301A	277	RPB261M	262, 264
ROPS36S0NN	354	ROWO90T0DH	362	RP301E(L/R)	278	RPB262K	256, 259
ROPS42S0NN	354	ROWO90T0()	355	RP301K	267, 269	RPB262L	262, 264
ROPS48S0NN	354	ROWO90T1DH	362	RP301L	271, 272	RPB262M	262, 264
ROPS54S0NN	354	ROWO90T1()	355	RP301M	271, 272	RPCB16	279
ROPS60S0NN	354	ROWO96S0DH	361	RP301R	275, 276	RPCB19	279
ROPS66S0NN	354	ROWO96S0()	355	RP301S	275, 276	RPCB30	279
ROPS72S0NN	354	ROWO96S1DH	361	RP301T	275, 276	RPCB36	279
ROPS78S0NN	354	ROWO96S1()	355	RP302A	277	RPCG	424
ROPS84S0NN	354	ROWO96T0DH	362	RP302E(L/R)	278	RPCST	424
ROPS90S0NN	354	ROWO96T0()	355	RP302K	267, 269	RPD11	426
ROPS96S0NN	354	ROWO96T1DH	362	RP302L	271, 272	RPD14	426
ROSDH821	365	ROWO96T1()	355	RP302M	271, 272	RPDHB16	272
ROSSH681	365	RP161J	267, 269	RP302R	275, 276	RPDHB19	272
ROWH60S0DH	363	RP161K	267, 269	RP302S	275, 276	RPDHB30	272
ROWH60S0()	355	RP161L(L/R)	271, 272	RP302T	275, 276	RPDHB36	272
ROWH60S1DH	363	RP161M	271, 272	RP361A	277	RPDHBFB6	279
ROWH60S1()	355	RP161R	275, 276	RP361E(L/R)	278	RPDHC42MF	279
ROWH60T0DH	364	RP162J	267, 269	RP361K	267, 269	RPDHC48MF	279
ROWH60T0()	355	RP162K	267, 269	RP361L	271, 272	RPDHC54MF	279
ROWH60T1DH	364	RP162L(L/R)	271, 272	RP361M	271, 272	RPDHC60MF	279
ROWH60T1()	355	RP162M	271, 272	RP361R	275, 276	RPDHC66MF	279
ROWH72S0DH	363	RP162R	275, 276	RP361S	275, 276	RPDHC72MF	279
ROWH72S0()	355	RP163J	267, 269	RP361T	275, 276	RPDHC78MF	279
ROWH72S1DH	363	RP163K	267, 269	RP362A	277	RPDHC84MF	279
ROWH72S1()	355	RP163L(L/R)	271, 272	RP362E(L/R)	278	RPDHC90MF	279
ROWH72T0DH	364	RP163M	271, 272	RP362K	267, 269	RPDHC96MF	279
ROWH72T0()	355	RP191J	268, 270	RP362L	271, 272	RPETAD	426
ROWH72T1DH	364	RP191K	268, 270	RP362M	271, 272	RPETRAY3C	426
ROWH72T1()	355	RP191R	275, 276	RP362R	275, 276	RPETRAY3N	426
ROWH90S0DH	363	RP192J	268, 270	RP362S	275, 276	RPFC6	279
ROWH90S0()	355	RP192K	268, 270	RP362T	275, 276	RPHCHH	425



<i>pattern no.</i>	<i>page</i>	<i>pattern no.</i>	<i>page</i>	<i>pattern no.</i>	<i>page</i>	<i>pattern no.</i>	<i>page</i>
RPHCHT	425	RPTDLPC(L/R)7830	207	RPTDOPC(L/R)7236	216	RPTDRPC(L/R)8430	210
RPHL3442(F/T)	114	RPTDLPC(L/R)7836	207	RPTDOPC(L/R)7820	216	RPTDRPC(L/R)8436	210
RPHL3449(F/T)	114	RPTDLPC(L/R)8420	207	RPTDOPC(L/R)7824	216	RPTDRST(L/R)6020	211
RPHL3464(F/T)	114	RPTDLPC(L/R)8424	207	RPTDOPC(L/R)7830	216	RPTDRST(L/R)6024	211
RPHL3479(F/T)	114	RPTDLPC(L/R)8430	207	RPTDOPC(L/R)7836	216	RPTDRST(L/R)6030	211
RPHL4249(F/T)	114	RPTDLPC(L/R)8436	207	RPTDOPC(L/R)8420	216	RPTDRST(L/R)6036	211
RPHLA249S	114	RPTDLST(L/R)6020	208	RPTDOPC(L/R)8424	216	RPTDRST(L/R)6620	211
RPHLA264(F/T)	114	RPTDLST(L/R)6024	208	RPTDOPC(L/R)8430	216	RPTDRST(L/R)6624	211
RPHLA264S	114	RPTDLST(L/R)6030	208	RPTDOPC(L/R)8436	216	RPTDRST(L/R)6630	211
RPHLA279(F/T)	114	RPTDLST(L/R)6036	208	RPTDOST(L/R)6030	217	RPTDRST(L/R)6636	211
RPHLA279S	114	RPTDLST(L/R)6620	208	RPTDOST(L/R)6036	217	RPTDRST(L/R)7220	211
RPHLA964(F/T)	114	RPTDLST(L/R)6624	208	RPTDOST(L/R)6630	217	RPTDRST(L/R)7224	211
RPHLA964S	114	RPTDLST(L/R)6630	208	RPTDOST(L/R)6636	217	RPTDRST(L/R)7230	211
RPHLA979(F/T)	114	RPTDLST(L/R)6636	208	RPTDOST(L/R)7230	217	RPTDRST(L/R)7236	211
RPHLA979S	114	RPTDLST(L/R)7220	208	RPTDOST(L/R)7236	217	RPTDRST(L/R)7820	211
RPHL6479(F/T)	114	RPTDLST(L/R)7224	208	RPTDOST(L/R)7830	217	RPTDRST(L/R)7824	211
RPHL6479S	114	RPTDLST(L/R)7230	208	RPTDOST(L/R)7836	217	RPTDRST(L/R)7830	211
RPHTB3024	425	RPTDLST(L/R)7236	208	RPTDOST(L/R)8430	217	RPTDRST(L/R)7836	211
RPHTB4224	425	RPTDLST(L/R)7820	208	RPTDOST(L/R)8436	217	RPTDRST(L/R)8420	211
RPHWB3024	425	RPTDLST(L/R)7824	208	RPTDRFM(L/R)4820	212	RPTDRST(L/R)8424	211
RPHWB4224	425	RPTDLST(L/R)7830	208	RPTDRFM(L/R)4824	212	RPTDRST(L/R)8430	211
RPTDCFM8430	222	RPTDLST(L/R)7836	208	RPTDRFM(L/R)4830	212	RPTDRST(L/R)8436	211
RPTDCFM9630	222	RPTDLST(L/R)8420	208	RPTDRFM(L/R)4836	212	RPTDSFM(L/R)4830	215
RPTDLFM(L/R)4820	209	RPTDLST(L/R)8424	208	RPTDRFM(L/R)5420	212	RPTDSFM(L/R)4836	215
RPTDLFM(L/R)4824	209	RPTDLST(L/R)8430	208	RPTDRFM(L/R)5424	212	RPTDSFM(L/R)5430	215
RPTDLFM(L/R)4830	209	RPTDLST(L/R)8436	208	RPTDRFM(L/R)5430	212	RPTDSFM(L/R)5436	215
RPTDLFM(L/R)4836	209	RPTDOFM(L/R)4820	218	RPTDRFM(L/R)5436	212	RPTDSFM(L/R)6030	215
RPTDLFM(L/R)5420	209	RPTDOFM(L/R)4824	218	RPTDRFM(L/R)6020	212	RPTDSFM(L/R)6036	215
RPTDLFM(L/R)5424	209	RPTDOFM(L/R)4830	218	RPTDRFM(L/R)6024	212	RPTDSFM(L/R)6630	215
RPTDLFM(L/R)5430	209	RPTDOFM(L/R)4836	218	RPTDRFM(L/R)6030	212	RPTDSFM(L/R)6636	215
RPTDLFM(L/R)5436	209	RPTDOFM(L/R)5420	218	RPTDRFM(L/R)6036	212	RPTDSFM(L/R)7230	215
RPTDLFM(L/R)6020	209	RPTDOFM(L/R)5424	218	RPTDRFM(L/R)6620	212	RPTDSFM(L/R)7236	215
RPTDLFM(L/R)6024	209	RPTDOFM(L/R)5430	218	RPTDRFM(L/R)6624	212	RPTDSFM(L/R)7830	215
RPTDLFM(L/R)6030	209	RPTDOFM(L/R)5436	218	RPTDRFM(L/R)6630	212	RPTDSFM(L/R)7836	215
RPTDLFM(L/R)6036	209	RPTDOFM(L/R)6020	218	RPTDRFM(L/R)6636	212	RPTDSFM(L/R)8430	215
RPTDLFM(L/R)6620	209	RPTDOFM(L/R)6024	218	RPTDRFM(L/R)7220	212	RPTDSFM(L/R)8436	215
RPTDLFM(L/R)6624	209	RPTDOFM(L/R)6030	218	RPTDRFM(L/R)7224	212	RPTDSPC(L/R)6030	213
RPTDLFM(L/R)6630	209	RPTDOFM(L/R)6036	218	RPTDRFM(L/R)7230	212	RPTDSPC(L/R)6036	213
RPTDLFM(L/R)6636	209	RPTDOFM(L/R)6620	218	RPTDRFM(L/R)7236	212	RPTDSPC(L/R)6630	213
RPTDLFM(L/R)7220	209	RPTDOFM(L/R)6624	218	RPTDRFM(L/R)7820	212	RPTDSPC(L/R)6636	213
RPTDLFM(L/R)7224	209	RPTDOFM(L/R)6630	218	RPTDRFM(L/R)7824	212	RPTDSPC(L/R)7230	213
RPTDLFM(L/R)7230	209	RPTDOFM(L/R)6636	218	RPTDRFM(L/R)7830	212	RPTDSPC(L/R)7236	213
RPTDLFM(L/R)7236	209	RPTDOFM(L/R)7220	218	RPTDRFM(L/R)7836	212	RPTDSPC(L/R)7830	213
RPTDLFM(L/R)7820	209	RPTDOFM(L/R)7224	218	RPTDRFM(L/R)8420	212	RPTDSPC(L/R)7836	213
RPTDLFM(L/R)7824	209	RPTDOFM(L/R)7230	218	RPTDRFM(L/R)8424	212	RPTDSPC(L/R)8430	213
RPTDLFM(L/R)7830	209	RPTDOFM(L/R)7236	218	RPTDRFM(L/R)8430	212	RPTDSPC(L/R)8436	213
RPTDLFM(L/R)7836	209	RPTDOFM(L/R)7820	218	RPTDRFM(L/R)8436	212	RPTDSST(L/R)6030	214
RPTDLFM(L/R)8420	209	RPTDOFM(L/R)7824	218	RPTDRPC(L/R)6020	210	RPTDSST(L/R)6036	214
RPTDLFM(L/R)8424	209	RPTDOFM(L/R)7830	218	RPTDRPC(L/R)6024	210	RPTDSST(L/R)6630	214
RPTDLFM(L/R)8430	209	RPTDOFM(L/R)7836	218	RPTDRPC(L/R)6030	210	RPTDSST(L/R)6636	214
RPTDLFM(L/R)8436	209	RPTDOFM(L/R)8420	218	RPTDRPC(L/R)6036	210	RPTDSST(L/R)7230	214
RPTDLPC(L/R)6020	207	RPTDOFM(L/R)8424	218	RPTDRPC(L/R)6620	210	RPTDSST(L/R)7236	214
RPTDLPC(L/R)6024	207	RPTDOFM(L/R)8430	218	RPTDRPC(L/R)6624	210	RPTDSST(L/R)7830	214
RPTDLPC(L/R)6030	207	RPTDOFM(L/R)8436	218	RPTDRPC(L/R)6630	210	RPTDSST(L/R)7836	214
RPTDLPC(L/R)6036	207	RPTDOPC(L/R)6020	216	RPTDRPC(L/R)6636	210	RPTDSST(L/R)8430	214
RPTDLPC(L/R)6620	207	RPTDOPC(L/R)6024	216	RPTDRPC(L/R)7220	210	RPTDSST(L/R)8436	214
RPTDLPC(L/R)6624	207	RPTDOPC(L/R)6030	216	RPTDRPC(L/R)7224	210	RR3-2PF	133
RPTDLPC(L/R)6630	207	RPTDOPC(L/R)6036	216	RPTDRPC(L/R)7230	210	RR3-3PF	133
RPTDLPC(L/R)6636	207	RPTDOPC(L/R)6620	216	RPTDRPC(L/R)7236	210	RR3-BNC	133
RPTDLPC(L/R)7220	207	RPTDOPC(L/R)6624	216	RPTDRPC(L/R)7820	210	RR3-C3C	133
RPTDLPC(L/R)7224	207	RPTDOPC(L/R)6630	216	RPTDRPC(L/R)7824	210	RR3-C5C	133
RPTDLPC(L/R)7230	207	RPTDOPC(L/R)6636	216	RPTDRPC(L/R)7830	210	RR3-C5C4A	133
RPTDLPC(L/R)7236	207	RPTDOPC(L/R)7220	216	RPTDRPC(L/R)7836	210	RR3-C5C4B	133
RPTDLPC(L/R)7820	207	RPTDOPC(L/R)7224	216	RPTDRPC(L/R)8420	210	RR3-C6C	133
RPTDLPC(L/R)7824	207	RPTDOPC(L/R)7230	216	RPTDRPC(L/R)8424	210	RR3CHI241	130

<i>pattern no.</i>	<i>page</i>	<i>pattern no.</i>	<i>page</i>	<i>pattern no.</i>	<i>page</i>	<i>pattern no.</i>	<i>page</i>
RR3CHI242	130	RR3-EJ90P	127	RR3-TJ42	129	RAA(A/B/C/D/E/F/G)12048-(1/2/3)	168
RR3CHI301	130	RR3-EJ96P	127	RR3-TJ42P	129	RAA(A/B/C/D/E/F/G)14442-(1/2/3)	168
RR3CHI302	130	RR3-EPC	126	RR3-TJ48	129	RAA(A/B/C/D/E/F/G)14448-(1/2/3)	168
RR3CHI361	130	RR3-EPC24	126	RR3TJ48	132	RAA(A/B/C/D/E/F/G)16842-(1/2/3)	168
RR3CHI362	130	RR3-EPCP	126	RR3-TJ48P	129	RAA(A/B/C/D/E/F/G)16848-(1/2/3)	168
RR3CHI421	130	RR3-EPCP24	126	RR3-TJ54P	129	RAA(A/B/C/D/E/F/G)19242-(1/2/3)	168
RR3CHI422	130	RR3-EPCPS	126	RR3-TJ60P	129	RAA(A/B/C/D/E/F/G)19248-(1/2/3)	168
RR3CHI481	130	RR3-EPCS	126	RR3TJ60P	132	RAA(A/B/C/D/E/F/G)3636-(1/2/3)	168
RR3CHI482	130	RR3-EPI	127	RR3-TJ66P	129	RAA(A/B/C/D/E/F/G)4242-(1/2/3)	168
RR3-DA	126, 128	RR3-EPNY1	127	RR3TJ66P	132	RAA(A/B/C/D/E/F/G)4848-(1/2/3)	168
RR3-DATSHD	126, 128	RR3-EPNY2	127	RR3-TJ72P	129	RAA(A/B/C/D/E/F/G)6060-(1/2/3)	168
RR3-DB	126, 128	RR3-EPVR	113, 127	RR3TJ72P	132	RAA(A/B/C/D/E/F/G)7230-(1/2/3)	168
RR3-DC	128	RR3EVJ	136	RR3-TJ78P	129	RAA(A/B/C/D/E/F/G)7236-(1/2/3)	168
RR3-DICON	133	RR3EVJ110	136	RR3-TJ84P	129	RAA(A/B/C/D/E/F/G)7272-(1/2/3)	168
RR3-DX	126, 128	RR3EVJ82	136	RR3-TJ90P	129	RAA(A/B/C/D/E/F/G)8430-(1/2/3)	168
RR3-DXO	126, 128	RR3EVJ96	136	RR3-TJ96P	129	RAA(A/B/C/D/E/F/G)8436-(1/2/3)	168
RR3-DY	126, 128	RR3-FB	133	RR3-TPC	128	RAA(A/B/C/D/E/F/G)8442-(1/2/3)	168
RR3-DYO	126, 128	RR3FDP	135	RR3-TPC24	128	RAA(A/B/C/D/E/F/G)9630-(1/2/3)	168
RR3-DZ	128	RR3-FE	133	RR3-TPCP	128	RAA(A/B/C/D/E/F/G)9636-(1/2/3)	168
RR3-DZO	128	RR3-FOSC	133	RR3-TPCP24	128	RAA(A/B/C/D/E/F/G)9642-(1/2/3)	168
RR3-E24	126	RR3-FOST	133	RR3-TPCPS	128	RRAW 12036-(1/2/3)	187
RR3-E24S	131	RR3-FV	133	RR3-TPCS	128	RRAW 12042-(1/2/3)	187
RR3-E30NS	126	RR3-LTPC	131	RR3-TPI	129	RRAW 14442-(1/2/3)	187
RR3-E30S	131	RR3-LTPC24	131	RR3-TPNY1	129	RRAW 16842-(1/2/3)	187
RR3-E36NS	126	RR3-LTPCP	131	RR3-TPNY2	129	RRAW 19242-(1/2/3)	187
RR3-E36S	131	RR3-MICON	133	RR3-TPVR	113, 129	RRAW 3636-(1/2/3)	187
RR3-E42NS	126	RR3MP4	421	RR3TVJ	136	RRAW 4242-(1/2/3)	187
RR3-E42S	131	RR3MP6	421	RR3TVJ110	136	RRAW 6060-(1/2/3)	187
RR3-E48NS	126	RR3PICON	133	RR3TVJ82	136	RRAW 7230-(1/2/3)	187
RR3-E48S	131	RR3-REPI	127	RR3TVJ96	136	RRAW 7236-(1/2/3)	187
RR3-E60-4	126	RR3-RTPI	129	RR3VDA	135	RRAW 7272-(1/2/3)	187
RR3-E66-4	126	RR3-SP-(A, B, C, X, Y, Z)	129	RR3VDB	135	RRAW 8430-(1/2/3)	187
RR3-E72-4	126	RR3-SP-(A,B,X,Y)	127	RR3VDC	135	RRAW 8436-(1/2/3)	187
RR3-EBBCL	131	RR3-ST	133	RR3VDX	135	RRAW 8442-(1/2/3)	187
RR3-EBBCS	131	RR3-T24	128	RR3VDXO	135	RRAW 9630-(1/2/3)	187
RR3EBVC50	135	RR3-T24S	131	RR3VDY	135	RRAW 9636-(1/2/3)	187
RR3EBVC62	135	RR3-T30NS	128	RR3VDYO	135	RRAW 9642-(1/2/3)	187
RR3EBVC64	135	RR3-T30S	131	RR3VDZ	135	RRBRD2712	421
RR3EBVC76	135	RR3-T36NS	128	RR3VDZO	135	RRD3FTCPPL(L/R)7936	116
RR3EBVC78	135	RR3-T36S	131	RR3VPBK	135	RRD3FTCPPL(L/R)7942	116
RR3EBVC90	135	RR3-T42NS	128	RAA12036	151	RRD3PPL(L/R)7936	116
RR3-EJ18	127	RR3-T42S	131	RAA12042	151	RRD3PPL(L/R)7942	116
RR3-EJ18P	127	RR3-T48NS	128	RAA12048	151	RRDPPL(L/R)6436	116
RR3-EJ20	127	RR3-T48S	131	RAA14442	151	RRDPPL(L/R)6442	116
RR3-EJ20P	127	RR3-T60-4	128	RAA14448	151	RRDTH	116
RR3-EJ24	127	RR3-T66-4	128	RAA16842	151	RRDTH(L/R)	116
RR3-EJ24P	127	RR3-T72-4	128	RAA16848	151	RREP3624(A,B,W)(F,N)2	415
RR3-EJ30	127	RR3-TBBCL	131	RAA19242	151	RREP3630(A,B,W)(F,N)2	415
RR3-EJ30P	127	RR3-TBBCS	131	RAA19248	151	RREP4224(A,B,W)(F,N)2	415
RR3-EJ36	127	RR3TBVC50	135	RAA3636	151	RREP4230(A,B,W)(F,N)2	415
RR3-EJ36P	127	RR3TBVC62	135	RAA4242	151	RREP4824(A,B,W)(F,N)2	415
RR3-EJ42	127	RR3TBVC64	135	RAA4848	151	RREP4830(A,B,W)(F,N)2	415
RR3-EJ42P	127	RR3TBVC76	135	RAA6060	151	RREP5424(A,B,W)(F,N)2	415
RR3-EJ48	127	RR3TBVC78	135	RAA7230	151	RREP5430(A,B,W)(F,N)2	415
RR3EJ48	132	RR3TBVC90	135	RAA7236	151	RREP6024(A,B,W)(F,N)2	415
RR3-EJ48P	127	RR3-TJ18	129	RAA7272	151	RREP6030(A,B,W)(F,N)2	415
RR3-EJ54P	127	RR3-TJ18P	129	RAA8430	151	RRLCFDC20108	281
RR3-EJ60P	127	RR3-TJ20	129	RAA8436	151	RRLCFDC2090	281
RR3EJ60P	132	RR3-TJ20P	129	RAA8442	151	RRLCFDCC20108	281
RR3-EJ66P	127	RR3-TJ24	129	RAA9630	151	RRLCFDCC2090	281
RR3EJ66P	132	RR3-TJ24P	129	RAA9636	151	RRLCFDCL2060	281
RR3-EJ72P	127	RR3-TJ30	129	RAA9642	151	RRLCFDCL2072	281
RR3EJ72P	132	RR3-TJ30P	129	RAA9648	151	RRLCFDCR2060	281
RR3-EJ78P	127	RR3-TJ36	129	RAA(A/B/C/D/E/F/G)12036-(1/2/3)	168	RRLCFDCR2072	281
RR3-EJ84P	127	RR3-TJ36P	129	RAA(A/B/C/D/E/F/G)12042-(1/2/3)	168	RRLCO20108	282

<i>pattern no.</i>	<i>page</i>	<i>pattern no.</i>	<i>page</i>	<i>pattern no.</i>	<i>page</i>	<i>pattern no.</i>	<i>page</i>
RRLCO2060	282	RROMWSD72GL	403	RSA842	137	RSA(A/B/C/D/E/F/G)F303	155
RRLCO2072	282	RROMWSD72GR	403	RSA843	138	RSA(A/B/C/D/E/F/G)F361	154
RRLCO2090	282	RROMWSD90GB	403	RSA901	137	RSA(A/B/C/D/E/F/G)F362	154
RRLCSGD20108	283	RROMWSD90GN	403	RSA902	137	RSA(A/B/C/D/E/F/G)F363	155
RRLCSGD2090	283	RROMWSDL60GB	404	RSA903	138	RSA(A/B/C/D/E/F/G)F421	154
RRLCSGDL2060	283	RROMWSDL72GB	404	RSA961	137	RSA(A/B/C/D/E/F/G)F422	154
RRLCSGDL2072	283	RROMWSDR60GB	404	RSA962	137	RSA(A/B/C/D/E/F/G)F423	155
RRLCSGDR2060	283	RROMWSDR72CB	404	RSA963	138	RSA(A/B/C/D/E/F/G)F481	154
RRLCSGDR2072	283	RRSP3624K(A,B,W)	415	RSA(A/B/C/D/E/F/G)A241	156	RSA(A/B/C/D/E/F/G)F482	154
RRLCSWD20108	284	RRSP3630K(A,B,W)	415	RSA(A/B/C/D/E/F/G)A242	156	RSA(A/B/C/D/E/F/G)F483	155
RRLCSWD2090	284	RRSP4224K(A,B,W)	415	RSA(A/B/C/D/E/F/G)A243	157	RSA(A/B/C/D/E/F/G)F541	154
RRLCSWDL2060	284	RRSP4230K(A,B,W)	415	RSA(A/B/C/D/E/F/G)A301	156	RSA(A/B/C/D/E/F/G)F542	154
RRLCSWDL2072	284	RRSP4824K(A,B,W)	415	RSA(A/B/C/D/E/F/G)A302	156	RSA(A/B/C/D/E/F/G)F543	155
RRLCSWDR2060	284	RRSP4830K(A,B,W)	415	RSA(A/B/C/D/E/F/G)A303	157	RSA(A/B/C/D/E/F/G)F601	154
RRLCSWDR2072	284	RRSP5424K(A,B,W)	415	RSA(A/B/C/D/E/F/G)A361	156	RSA(A/B/C/D/E/F/G)F602	154
RRMC3010	491	RRSP5430K(A,B,W)	415	RSA(A/B/C/D/E/F/G)A362	156	RSA(A/B/C/D/E/F/G)F603	155
RRMC3610	491	RRSP6024K(A,B,W)	415	RSA(A/B/C/D/E/F/G)A363	157	RSA(A/B/C/D/E/F/G)F604	155
RRMC6010	491	RRSP6030K(A,B,W)	415	RSA(A/B/C/D/E/F/G)A421	156	RSA(A/B/C/D/E/F/G)F661	154
RRMC7210	491	RSI-N30	393	RSA(A/B/C/D/E/F/G)A422	156	RSA(A/B/C/D/E/F/G)F662	154
RRML108	405	RSI-N36	393	RSA(A/B/C/D/E/F/G)A423	157	RSA(A/B/C/D/E/F/G)F663	155
RRML60	405	RSI-N42	393	RSA(A/B/C/D/E/F/G)A481	156	RSA(A/B/C/D/E/F/G)F664	155
RRML72	405	RSI-N48	393	RSA(A/B/C/D/E/F/G)A482	156	RSA(A/B/C/D/E/F/G)F721	154
RRML90	405	RSI-N60	393	RSA(A/B/C/D/E/F/G)A483	157	RSA(A/B/C/D/E/F/G)F722	154
RROCGSD108GB	398	RSI-RPB	395	RSA(A/B/C/D/E/F/G)A541	156	RSA(A/B/C/D/E/F/G)F723	155
RROCGSD90GB	398	RSI-VP	393	RSA(A/B/C/D/E/F/G)A542	156	RSA(A/B/C/D/E/F/G)F724	155
RROCGSDL60GB	398	RSI-WMF24	396	RSA(A/B/C/D/E/F/G)A543	157	RSA(A/B/C/D/E/F/G)F781	154
RROCGSDL72GB	398	RSI-WMF30	396	RSA(A/B/C/D/E/F/G)A601	156	RSA(A/B/C/D/E/F/G)F782	154
RROCGSDR60GB	398	RSI-WMF36	396	RSA(A/B/C/D/E/F/G)A602	156	RSA(A/B/C/D/E/F/G)F783	155
RROCGSDR72GB	398	RSI-WMF42	396	RSA(A/B/C/D/E/F/G)A603	157	RSA(A/B/C/D/E/F/G)F841	154
RROCOS108GB	400	RSI-WMF48	396	RSA(A/B/C/D/E/F/G)A604	157	RSA(A/B/C/D/E/F/G)F842	154
RROCOS60GB	400	RSI-WMF60	396	RSA(A/B/C/D/E/F/G)A661	156	RSA(A/B/C/D/E/F/G)F843	155
RROCOS72GB	400	RSA241	137	RSA(A/B/C/D/E/F/G)A662	156	RSA(A/B/C/D/E/F/G)F901	154
RROCOS90GB	400	RSA242	137	RSA(A/B/C/D/E/F/G)A663	157	RSA(A/B/C/D/E/F/G)F902	154
RROCWSD108GB	399	RSA243	138	RSA(A/B/C/D/E/F/G)A664	157	RSA(A/B/C/D/E/F/G)F903	155
RROCWSD90GB	399	RSA301	137	RSA(A/B/C/D/E/F/G)A721	156	RSA(A/B/C/D/E/F/G)F961	154
RROCWSDL60GB	399	RSA302	137	RSA(A/B/C/D/E/F/G)A722	156	RSA(A/B/C/D/E/F/G)F962	154
RROCWSDL72GB	399	RSA303	138	RSA(A/B/C/D/E/F/G)A723	157	RSA(A/B/C/D/E/F/G)F963	155
RROCWSDR60GB	399	RSA361	137	RSA(A/B/C/D/E/F/G)A724	157	RSA(A/B/C/D/E/F/G)L241	158
RROCWSDR72CB	399	RSA362	137	RSA(A/B/C/D/E/F/G)A781	156	RSA(A/B/C/D/E/F/G)L242	158
RROMGSD108GB	402	RSA363	138	RSA(A/B/C/D/E/F/G)A782	156	RSA(A/B/C/D/E/F/G)L301	158
RROMGSD108GN	401	RSA421	137	RSA(A/B/C/D/E/F/G)A783	157	RSA(A/B/C/D/E/F/G)L302	158
RROMGSD60GL	401	RSA422	137	RSA(A/B/C/D/E/F/G)A841	156	RSA(A/B/C/D/E/F/G)L361	158
RROMGSD60GR	401	RSA423	138	RSA(A/B/C/D/E/F/G)A842	156	RSA(A/B/C/D/E/F/G)L362	158
RROMGSD72GL	401	RSA481	137	RSA(A/B/C/D/E/F/G)A843	157	RSA(A/B/C/D/E/F/G)L421	158
RROMGSD72GR	401	RSA482	137	RSA(A/B/C/D/E/F/G)A901	156	RSA(A/B/C/D/E/F/G)L422	158
RROMGSD90GB	402	RSA483	138	RSA(A/B/C/D/E/F/G)A902	156	RSA(A/B/C/D/E/F/G)L481	158
RROMGSD90GN	401	RSA541	137	RSA(A/B/C/D/E/F/G)A903	157	RSA(A/B/C/D/E/F/G)L482	158
RROMGSDL60GB	402	RSA542	137	RSA(A/B/C/D/E/F/G)A961	156	RSA(A/B/C/D/E/F/G)R241	159
RROMGSDL72GB	402	RSA543	138	RSA(A/B/C/D/E/F/G)A962	156	RSA(A/B/C/D/E/F/G)R242	159
RROMGSDR60GB	402	RSA601	137	RSA(A/B/C/D/E/F/G)A963	157	RSA(A/B/C/D/E/F/G)R301	159
RROMGSDR72CB	402	RSA602	137	RSA(A/B/C/D/E/F/G)B241	158	RSA(A/B/C/D/E/F/G)R302	159
RROMOS108GB	406	RSA603	138	RSA(A/B/C/D/E/F/G)B242	158	RSA(A/B/C/D/E/F/G)R361	159
RROMOS108GN	406	RSA604	138	RSA(A/B/C/D/E/F/G)B301	158	RSA(A/B/C/D/E/F/G)R362	159
RROMOS60GB	406	RSA661	137	RSA(A/B/C/D/E/F/G)B302	158	RSA(A/B/C/D/E/F/G)R421	159
RROMOS60GL	406	RSA662	137	RSA(A/B/C/D/E/F/G)B361	158	RSA(A/B/C/D/E/F/G)R422	159
RROMOS60GR	406	RSA663	138	RSA(A/B/C/D/E/F/G)B362	158	RSA(A/B/C/D/E/F/G)R481	159
RROMOS72GB	406	RSA664	138	RSA(A/B/C/D/E/F/G)B421	158	RSA(A/B/C/D/E/F/G)R482	159
RROMOS72GL	406	RSA721	137	RSA(A/B/C/D/E/F/G)B422	158	RSAMP1616	421
RROMOS72GR	406	RSA722	137	RSA(A/B/C/D/E/F/G)B481	158	RSAWA241	171
RROMOS90GB	406	RSA723	138	RSA(A/B/C/D/E/F/G)B482	158	RSAWA242	171
RROMOS90GN	406	RSA724	138	RSA(A/B/C/D/E/F/G)F241	154	RSAWA243	172
RROMWSD108GB	403	RSA781	137	RSA(A/B/C/D/E/F/G)F242	154	RSAWA301	171
RROMWSD108GN	403	RSA782	137	RSA(A/B/C/D/E/F/G)F243	155	RSAWA302	171
RROMWSD60GL	403	RSA783	138	RSA(A/B/C/D/E/F/G)F301	154	RSAWA303	172
RROMWSD60GR	403	RSA841	137	RSA(A/B/C/D/E/F/G)F302	154	RSAWA361	171

<i>pattern no.</i>	<i>page</i>	<i>pattern no.</i>	<i>page</i>	<i>pattern no.</i>	<i>page</i>	<i>pattern no.</i>	<i>page</i>
RSAWA362	171	RSAWB781	173	RSAWL423	176	RSAWR842	177
RSAWA363	172	RSAWB782	173	RSAWL481	175	RSAWR843	178
RSAWA421	171	RSAWB783	174	RSAWL482	175	RSAWR901	177
RSAWA422	171	RSAWB841	173	RSAWL483	176	RSAWR902	177
RSAWA423	172	RSAWB842	173	RSAWL541	175	RSAWR903	178
RSAWA481	171	RSAWB843	174	RSAWL542	175	RSAWR961	177
RSAWA482	171	RSAWB901	173	RSAWL543	176	RSAWR962	177
RSAWA483	172	RSAWB902	173	RSAWL601	175	RSAWR963	178
RSAWA541	171	RSAWB903	174	RSAWL602	175	RSBWH20	237
RSAWA542	171	RSAWB961	173	RSAWL603	176	RSBWH24	237
RSAWA543	172	RSAWB962	173	RSAWL604	176	RSBWH30	237
RSAWA601	171	RSAWB963	174	RSAWL661	175	RSBWH36	237
RSAWA602	171	RSAWF241	169	RSAWL662	175	RSBWH42	237
RSAWA603	172	RSAWF242	169	RSAWL663	176	RSBWH48	237
RSAWA604	172	RSAWF243	170	RSAWL664	176	RSC	244
RSAWA661	171	RSAWF301	169	RSAWL721	175	RSC4	244
RSAWA662	171	RSAWF302	169	RSAWL722	175	RSD1021	194
RSAWA663	172	RSAWF303	170	RSAWL723	176	RSD1022	194
RSAWA664	172	RSAWF361	169	RSAWL724	176	RSD1023	195
RSAWA721	171	RSAWF362	169	RSAWL781	175	RSD1081	194
RSAWA722	171	RSAWF363	170	RSAWL782	175	RSD1082	194
RSAWA723	172	RSAWF421	169	RSAWL783	176	RSD1083	195
RSAWA724	172	RSAWF422	169	RSAWL841	175	RSD1427	245, 246
RSAWA781	171	RSAWF423	170	RSAWL842	175	RSD1827	245, 246
RSAWA782	171	RSAWF481	169	RSAWL843	176	RSD2027	245, 246
RSAWA783	172	RSAWF482	169	RSAWL901	175	RSD241	194
RSAWA841	171	RSAWF483	170	RSAWL902	175	RSD242	194
RSAWA842	171	RSAWF541	169	RSAWL903	176	RSD2427	245, 246
RSAWA843	172	RSAWF542	169	RSAWL961	175	RSD243	195
RSAWA901	171	RSAWF543	170	RSAWL962	175	RSD301	194
RSAWA902	171	RSAWF601	169	RSAWL963	176	RSD302	194
RSAWA903	172	RSAWF602	169	RSAWR241	177	RSD3027	245, 246
RSAWA961	171	RSAWF603	170	RSAWR242	177	RSD303	195
RSAWA962	171	RSAWF604	170	RSAWR243	178	RSD361	194
RSAWA963	172	RSAWF661	169	RSAWR301	177	RSD362	194
RSAWB241	173	RSAWF662	169	RSAWR302	177	RSD363	195
RSAWB242	173	RSAWF663	170	RSAWR303	178	RSD421	194
RSAWB243	174	RSAWF664	170	RSAWR361	177	RSD422	194
RSAWB301	173	RSAWF721	169	RSAWR362	177	RSD423	195
RSAWB302	173	RSAWF722	169	RSAWR363	178	RSD481	194
RSAWB303	174	RSAWF723	170	RSAWR421	177	RSD482	194
RSAWB361	173	RSAWF724	170	RSAWR422	177	RSD483	195
RSAWB362	173	RSAWF781	169	RSAWR423	178	RSD541	194
RSAWB363	174	RSAWF782	169	RSAWR481	177	RSD542	194
RSAWB421	173	RSAWF783	170	RSAWR482	177	RSD543	195
RSAWB422	173	RSAWF841	169	RSAWR483	178	RSD601	194
RSAWB423	174	RSAWF842	169	RSAWR541	177	RSD602	194
RSAWB481	173	RSAWF843	170	RSAWR542	177	RSD603	195
RSAWB482	173	RSAWF901	169	RSAWR543	178	RSD604	195
RSAWB483	174	RSAWF902	169	RSAWR601	177	RSD661	194
RSAWB541	173	RSAWF903	170	RSAWR602	177	RSD662	194
RSAWB542	173	RSAWF961	169	RSAWR603	178	RSD663	195
RSAWB543	174	RSAWF962	169	RSAWR604	178	RSD664	195
RSAWB601	173	RSAWF963	170	RSAWR661	177	RSD721	194
RSAWB602	173	RSAWL241	175	RSAWR662	177	RSD722	194
RSAWB603	174	RSAWL242	175	RSAWR663	178	RSD723	195
RSAWB604	174	RSAWL243	176	RSAWR664	178	RSD724	195
RSAWB661	173	RSAWL301	175	RSAWR721	177	RSD781	194
RSAWB662	173	RSAWL302	175	RSAWR722	177	RSD782	194
RSAWB663	174	RSAWL303	176	RSAWR723	178	RSD783	195
RSAWB664	174	RSAWL361	175	RSAWR724	178	RSD841	194
RSAWB721	173	RSAWL362	175	RSAWR781	177	RSD842	194
RSAWB722	173	RSAWL363	176	RSAWR782	177	RSD843	195
RSAWB723	174	RSAWL421	175	RSAWR783	178	RSD901	194
RSAWB724	174	RSAWL422	175	RSAWR841	177	RSD902	194

<i>pattern no.</i>	<i>page</i>	<i>pattern no.</i>	<i>page</i>	<i>pattern no.</i>	<i>page</i>	<i>pattern no.</i>	<i>page</i>
RSD903	195	RSNTT48(A/B/C/E)	110	RSTSLE421	233	RSWWAWF721	359
RSD961	194	RSPABPD	115	RSTSLE422	233	RSWWAWF722	359
RSD962	194	RSPABPP	115	RSTSSE361	235	RSWWAWF901	359
RSD963	195	RSPABPT	115	RSTSSE362	235	RSWWAWF902	359
RSDHC	247	RSPABPW	115	RSTSSE421	235	RSWWAWF961	359
RSDHC3	248	RSPABTD	115	RSTSWE361	234	RSWWAWF962	359
RSDHC4	247	RSPABTT	115	RSTSWE362	234	RSWWB601	360
RSDHD1428	248, 249	RSPABTW	115	RSTSWE421	234	RSWWB602	360
RSDHD1828	248, 249	RSPABWD	115	RSTSWE422	234	RSWWB721	360
RSDHD2028	248, 249	RSPABWW	115	RSTTLE30481	233	RSWWB722	360
RSDHD2428	248, 249	RST	424	RSTTLE30482	233	RSWWB901	360
RSDHD3028	248, 249	RST1	246	RSTTLE36541	233	RSWWB902	360
RSDHL12	249	RST2	246	RSTTLE36542	233	RSWWB961	360
RSDHL15	249	RST3	246	RSTTSE30481	235	RSWWB962	360
RSDHL20	249	RST4	246	RSTTSE30482	235	RTA12036	152
RSDHL24	249	RST5	246	RSTTSE36541	235	RTA12042	152
RSDHL30	249	RST6	246	RSTTSE36542	235	RTA12048	152
RSDHL36	249	RSTDCFM(L/R)4830	221	RSTTWE30481	234	RTA14442	152
RSDHL42	249	RSTDCFM(L/R)4836	221	RSTTWE30482	234	RTA14448	152
RSDHL48	249	RSTDCFM(L/R)5430	221	RSTTWE36541	234	RTA16842	152
RSDHT1	249	RSTDCFM(L/R)5436	221	RSTTWE36542	234	RTA16848	152
RSDHT2	249	RSTDCFM(L/R)6030	221	RSWA15 18	101	RTA19242	152
RSDHT3	249	RSTDCFM(L/R)6036	221	RSWA15 20	101	RTA19248	152
RSDHT4	249	RSTDCFM(L/R)6630	221	RSWA15 24	101	RTA3636	152
RSDHT5	249	RSTDCFM(L/R)6636	221	RSWA15 30	101	RTA4242	152
RSDHT6	249	RSTDCFM(L/R)7230	221	RSWA15 36	101	RTA4848	152
RSDR30	431	RSTDCFM(L/R)7236	221	RSWA15 42	101	RTA6060	152
RSDR36	431	RSTDCFM(L/R)7830	221	RSWA15 48	101	RTA7230	152
RSDR42	431	RSTDCFM(L/R)7836	221	RSWAD1560	102	RTA7236	152
RSDR48	431	RSTDCFM(L/R)8430	221	RSWAD1572	102	RTA7272	152
RSDR54	431	RSTDCFM(L/R)8436	221	RSWAD1584	102	RTA8430	152
RSDR60	431	RSTDCPC(L/R)6030	219	RSWAD1596	102	RTA8436	152
RSDR66	431	RSTDCPC(L/R)6036	219	RSWAD2260	102	RTA8442	152
RSDR72	431	RSTDCPC(L/R)6630	219	RSWAD2272	102	RTA9630	152
RSDR78	431	RSTDCPC(L/R)6636	219	RSWAD2284	102	RTA9636	152
RSDR84	431	RSTDCPC(L/R)7230	219	RSWAD2296	102	RTA9642	152
RSDR90	431	RSTDCPC(L/R)7236	219	RSWB15 30	101	RTA9648	152
RSDR96	431	RSTDCPC(L/R)7830	219	RSWB15 36	101	RTA(A/B/C/D/E/F/G)12036-(1/2/3)	167
RSE1(L/R)	240	RSTDCPC(L/R)7836	219	RSWB15 42	101	RTA(A/B/C/D/E/F/G)12042-(1/2/3)	167
RSE2(L/R)	240	RSTDCPC(L/R)8430	219	RSWB15 48	101	RTA(A/B/C/D/E/F/G)12048-(1/2/3)	167
RSE3(L/R)	240	RSTDCPC(L/R)8436	219	RSWC30 18	101	RTA(A/B/C/D/E/F/G)14442-(1/2/3)	167
RSE4(L/R)	240	RSTDCST(L/R)6030	220	RSWC30 20	101	RTA(A/B/C/D/E/F/G)14448-(1/2/3)	167
RSE5(L/R)	240	RSTDCST(L/R)6036	220	RSWC30 24	101	RTA(A/B/C/D/E/F/G)16842-(1/2/3)	167
RSE6(L/R)	240	RSTDCST(L/R)6630	220	RSWC30 30	101	RTA(A/B/C/D/E/F/G)16848-(1/2/3)	167
RSEDH1(L/R)	242	RSTDCST(L/R)6636	220	RSWC30 36	101	RTA(A/B/C/D/E/F/G)19242-(1/2/3)	167
RSEDH2(L/R)	242	RSTDCST(L/R)7230	220	RSWC30 42	101	RTA(A/B/C/D/E/F/G)19248-(1/2/3)	167
RSEDH3(L/R)	242	RSTDCST(L/R)7236	220	RSWC30 48	101	RTA(A/B/C/D/E/F/G)3636-(1/2/3)	167
RSEDH4(L/R)	242	RSTDCST(L/R)7830	220	RSWWA601	359	RTA(A/B/C/D/E/F/G)4242-(1/2/3)	167
RSEDH5(L/R)	242	RSTDCST(L/R)7836	220	RSWWA602	359	RTA(A/B/C/D/E/F/G)4848-(1/2/3)	167
RSEDH6(L/R)	242	RSTDCST(L/R)8430	220	RSWWA721	359	RTA(A/B/C/D/E/F/G)6060-(1/2/3)	167
RSL12	246	RSTDCST(L/R)8436	220	RSWWA722	359	RTA(A/B/C/D/E/F/G)7230-(1/2/3)	167
RSL15	246	RSTRLE361	233	RSWWA901	359	RTA(A/B/C/D/E/F/G)7236-(1/2/3)	167
RSL20	246	RSTRLE362	233	RSWWA902	359	RTA(A/B/C/D/E/F/G)7272-(1/2/3)	167
RSL24	246	RSTRLE421	233	RSWWA961	359	RTA(A/B/C/D/E/F/G)8430-(1/2/3)	167
RSL30	246	RSTRLE422	233	RSWWA962	359	RTA(A/B/C/D/E/F/G)8436-(1/2/3)	167
RSL36	246	RSTRSE361	235	RSWWA(A/B/C/D/E/F/G)601	359	RTA(A/B/C/D/E/F/G)8442-(1/2/3)	167
RSL42	246	RSTRSE362	235	RSWWA(A/B/C/D/E/F/G)602	359	RTA(A/B/C/D/E/F/G)9630-(1/2/3)	167
RSL48	246	RSTRSE421	235	RSWWA(A/B/C/D/E/F/G)721	359	RTA(A/B/C/D/E/F/G)9636-(1/2/3)	167
RSNTT18(A/B/C/E)	110	RSTRSE422	235	RSWWA(A/B/C/D/E/F/G)722	359	RTA(A/B/C/D/E/F/G)9642-(1/2/3)	167
RSNTT20(A/B/C/E)	110	RSTRWE361	234	RSWWA(A/B/C/D/E/F/G)901	359	RTAT5E19S	397
RSNTT24(A/B/C/E)	110	RSTRWE362	234	RSWWA(A/B/C/D/E/F/G)902	359	RTAT5E25A	397
RSNTT30(A/B/C/E)	110	RSTRWE421	234	RSWWA(A/B/C/D/E/F/G)961	359	RTAT5E25S	397
RSNTT33(A/B/C/E) (66" wide panels one only)	110	RSTRWE422	234	RSWWA(A/B/C/D/E/F/G)962	359	RTAT5E37A	397
RSNTT36(A/B/C/E)	110	RSTSLE361	233	RSWWAWF601	359	RTAT5E37S	397
RSNTT42(A/B/C/E)	110	RSTSLE362	233	RSWWAWF602	359	RTAT5E49A	397

<i>pattern no.</i>	<i>page</i>	<i>pattern no.</i>	<i>page</i>	<i>pattern no.</i>	<i>page</i>	<i>pattern no.</i>	<i>page</i>
RTAT5E49S	397	RTPNM42H3	449, 450	RTPRS30H4	456, 457, 458	RTPRS84H1	443
RTAT5E61A	397	RTPNM42H4	454, 455	RTPRS30H5	461, 462, 463	RTPRS84H2	448
RTAT5E61S	397	RTPNM42H5	459, 460	RTPRS30H6	466, 467, 468	RTPRS84H3	453
RTAW12036-(1/2/3)	186	RTPNM42H6	464, 465	RTPRS30H7	470, 471, 472	RTPRS84H4	458
RTAW12042-(1/2/3)	186	RTPNM42H7	469	RTPRS30H8	474, 475, 476	RTPRS84H5	463
RTAW14442-(1/2/3)	186	RTPNM42H8	473	RTPRS36H1	441, 442, 443	RTPRS84H6	468
RTAW16842-(1/2/3)	186	RTPNM48H1	439, 440	RTPRS36H2	446, 447, 448	RTPRS90H1	443
RTAW19242-(1/2/3)	186	RTPNM48H2	444, 445	RTPRS36H3	451, 452, 453	RTPRS90H2	448
RTAW3636-(1/2/3)	186	RTPNM48H3	449, 450	RTPRS36H4	456, 457, 458	RTPRS90H3	453
RTAW4242-(1/2/3)	186	RTPNM48H4	454, 455	RTPRS36H5	461, 462, 463	RTPRS90H4	458
RTAW6060-(1/2/3)	186	RTPNM48H5	459, 460	RTPRS36H6	466, 467, 468	RTPRS90H5	463
RTAW7230-(1/2/3)	186	RTPNM48H6	464, 465	RTPRS36H7	470, 471, 472	RTPRS90H6	468
RTAW7236-(1/2/3)	186	RTPNM48H7	469	RTPRS36H8	474, 475, 476	RTPRS96H1	443
RTAW7272-(1/2/3)	186	RTPNM48H8	473	RTPRS42H1	441, 442, 443	RTPRS96H2	448
RTAW8430-(1/2/3)	186	RTPNM54H1	439, 440	RTPRS42H2	446, 447, 448	RTPRS96H3	453
RTAW8436-(1/2/3)	186	RTPNM54H2	444, 445	RTPRS42H3	451, 452, 453	RTPRS96H4	458
RTAW8442-(1/2/3)	186	RTPNM54H3	449, 450	RTPRS42H4	456, 457, 458	RTPRS96H5	463
RTAW9630-(1/2/3)	186	RTPNM54H4	454, 455	RTPRS42H5	461, 462, 463	RTPRS96H6	468
RTAW9636-(1/2/3)	186	RTPNM54H5	459, 460	RTPRS42H6	466, 467, 468	RTRDL48301	226
RTAW9642-(1/2/3)	186	RTPNM54H6	464	RTPRS42H7	470, 471, 472	RTRDL48302	226
RTLL193W	432	RTPNM60H1	439, 440	RTPRS42H8	474, 475, 476	RTRDL60301	226
RTLL196W	432	RTPNM60H2	444, 445	RTPRS48H1	441, 442, 443	RTRDL60302	226
RTLL199W	432	RTPNM60H3	449, 450	RTPRS48H2	446, 447, 448	RTRDL72301	226
RTLL3712W	432	RTPNM60H4	454, 455	RTPRS48H3	451, 452, 453	RTRDL72302	226
RTLL3718W	432	RTPNM60H5	459, 460	RTPRS48H4	456, 457, 458	RTRDL72361	226
RTLL376W	432	RTPNM60H6	464	RTPRS48H5	461, 462, 463	RTRDL72362	226
RTLT5E19S	432	RTPNM66H1	439, 440	RTPRS48H6	466, 467, 468	RTRDL72362	226
RTLT5E25A	432	RTPNM66H2	444, 445	RTPRS48H7	470, 471, 472	RTRDL72362	226
RTLT5E25S	432	RTPNM66H3	449, 450	RTPRS48H8	474, 475, 476	RTRDL72362	226
RTLT5E37A	432	RTPNM66H4	454, 455	RTPRS54H1	441, 442, 443	RTRDL72362	226
RTLT5E37S	432	RTPNM66H5	459, 460	RTPRS54H2	446, 447, 448	RTRDL72362	226
RTLT5E49A	432	RTPNM66H6	464	RTPRS54H3	451, 452, 453	RTRDL72362	226
RTLT5E49S	432	RTPNM72H1	439, 440	RTPRS54H4	456, 457, 458	RTRDL72362	226
RTLT5E61A	432	RTPNM72H2	444, 445	RTPRS54H5	461, 462, 463	RTRDL72362	226
RTLT5E61S	432	RTPNM72H3	449, 450	RTPRS54H6	466, 467, 468	RTRDL72362	226
RTLT5E73A	432	RTPNM72H4	454, 455	RTPRS54H7	470, 472	RTRDL72362	226
RTLT5E73S	432	RTPNM72H5	459, 460	RTPRS54H8	474, 476	RTRDL72362	226
RTLT5E85A	432	RTPNM72H6	464	RTPRS60H1	441, 442, 443	RTRDL72362	226
RTLT5E85S	432	RTPNM78H1	439, 440	RTPRS60H2	446, 447, 448	RTRDL72362	226
RTNDC361	232	RTPNM78H2	444, 445	RTPRS60H3	451, 452, 453	RTRDL72362	226
RTNDC362	232	RTPNM78H3	449, 450	RTPRS60H4	456, 457, 458	RTRDL72362	226
RTNDC421	232	RTPNM78H4	454, 455	RTPRS60H5	461, 462, 463	RTRDL72362	226
RTNDC422	232	RTPNM78H5	459, 460	RTPRS60H6	466, 467, 468	RTRDL72362	226
RTNDC481	232	RTPNM78H6	464	RTPRS60H7	470, 472	RTRDL72362	226
RTNDC482	232	RTPNM84H1	439, 440	RTPRS60H8	474, 476	RTRDL72362	226
RTOP1	421	RTPNM84H2	444, 445	RTPRS66H1	441, 442, 443	RTRDL72362	226
RTOP2	421	RTPNM84H3	449, 450	RTPRS66H2	446, 447, 448	RTRDL72362	226
RTPNM30H1	439, 440	RTPNM84H4	454, 455	RTPRS66H3	451, 452, 453	RTRDL72362	226
RTPNM30H2	444, 445	RTPNM84H5	459, 460	RTPRS66H4	456, 457, 458	RTRDL72362	226
RTPNM30H3	449, 450	RTPNM84H6	464	RTPRS66H5	461, 462, 463	RTRDL72362	226
RTPNM30H4	454, 455	RTPNM90H1	439, 440	RTPRS66H6	466, 467, 468	RTRDL72362	226
RTPNM30H5	459, 460	RTPNM90H2	444, 445	RTPRS66H8	474	RTRDL72362	226
RTPNM30H6	464, 465	RTPNM90H3	449, 450	RTPRS72H1	441, 442, 443	RTRDL72362	226
RTPNM30H7	469	RTPNM90H4	454, 455	RTPRS72H2	446, 447, 448	RTRDL72362	226
RTPNM30H8	473	RTPNM90H5	459, 460	RTPRS72H3	451, 452, 453	RTRDL72362	226
RTPNM36H1	439, 440	RTPNM90H6	464	RTPRS72H4	456, 457, 458	RTRDL72362	226
RTPNM36H2	444, 445	RTPNM96H1	439, 440	RTPRS72H5	461, 462, 463	RTRDL72362	226
RTPNM36H3	449, 450	RTPNM96H2	444, 445	RTPRS72H6	466, 468	RTRDL72362	226
RTPNM36H4	454, 455	RTPNM96H3	449, 450	RTPRS72H8	474	RTRDL72362	226
RTPNM36H5	459, 460	RTPNM96H4	454, 455	RTPRS78H1	443	RTRDL72362	226
RTPNM36H6	464, 465	RTPNM96H5	459, 460	RTPRS78H2	448	RTRDL72362	226
RTPNM36H7	469	RTPNM96H6	464	RTPRS78H3	453	RTRDL72362	226
RTPNM36H8	473	RTPRS30H1	441, 442, 443	RTPRS78H4	458	RTRDL72362	226
RTPNM42H1	439, 440	RTPRS30H2	446, 447, 448	RTPRS78H5	463	RTRDL72362	226
RTPNM42H2	444, 445	RTPRS30H3	451, 452, 453	RTPRS78H6	468	RTRDL72362	226

<i>pattern no.</i>	<i>page</i>	<i>pattern no.</i>	<i>page</i>	<i>pattern no.</i>	<i>page</i>	<i>pattern no.</i>	<i>page</i>
RTTA72()	407	RWAWF4212	179	RWEB7224(L/R)	356	RWHDHTB90H1	477
RTTAWF24()	407	RWAWF4221	179	RWEB7520(L/R)	365	RWHDHTB90H2	478
RTTAWF30()	407	RWAWF4223	179	RWEB7524(L/R)	365	RWHDHTB90H3	479
RTTAWF36()	407	RWAWF4232	179	RWEC7220(L/R)	356	RWHDHTB90H4	480
RTTAWF42()	407	RWAWF4812	179	RWEC7224(L/R)	356	RWHDHTB90H5	481
RTTAWF48()	407	RWAWF4821	179	RWEC7520(L/R)	365	RWHDHTB96H1	477
RTTAWF54()	407	RWAWF4823	179	RWEC7524(L/R)	365	RWHDHTB96H2	478
RTTAWF60()	407	RWAWF4832	179	RWED7220(L/R)	356	RWHDHTB96H3	479
RTTAWF66()	407	RWAWF5412	179	RWED7224(L/R)	356	RWHDHTB96H4	480
RTTAWF72()	407	RWAWF5421	179	RWED7520(L/R)	365	RWHDHTB96H5	481
RUMC3010	491	RWAWF5423	179	RWED7524(L/R)	365	RWHRA	421
RUMC3610	491	RWAWF5432	179	RWHDHTB3026	425	RWHRB	421
RUMC6010	492	RWAWF6012	179	RWHDHTB30H1	477	RWHRC	421
RUMC7210	492	RWAWF6021	179	RWHDHTB30H2	478	RWHRD	421
RUTB	238	RWAWF6023	179	RWHDHTB30H3	479	RWHRE	421
RWA3623	141	RWAWF6032	179	RWHDHTB30H4	480	RWHRF	421
RWA3632	141	RWAWF6612	179	RWHDHTB30H5	481	RWHRC	421
RWA4212	141	RWAWF6621	179	RWHDHTB3626	425	RWHTB3024	425
RWA4221	141	RWAWF6623	179	RWHDHTB36H1	477	RWHTB3624	425
RWA4223	141	RWAWF6632	179	RWHDHTB36H2	478	RWHTB4224	425
RWA4232	141	RWAWF7212	179	RWHDHTB36H3	479	RWHTB4824	425
RWA4812	141	RWAWF7221	179	RWHDHTB36H4	480	RWMCT24	423
RWA4821	141	RWAWF7223	179	RWHDHTB36H5	481	RWMMP24	422
RWA4823	141	RWAWF7232	179	RWHDHTB4226	425	RWMMP30	422
RWA4832	141	RWEA3613	142	RWHDHTB42H1	477	RWMMP36	422
RWA5412	141	RWEA3626	142	RWHDHTB42H2	478	RWMMPB	422
RWA5421	141	RWEA3631	142	RWHDHTB42H3	479	RWMV24	422
RWA5423	141	RWEA3662	142	RWHDHTB42H4	480	RWMVH24	422
RWA5432	141	RWEA4213	142	RWHDHTB42H5	481	RWMVH30	422
RWA6012	141	RWEA4226	142	RWHDHTB4826	425	RWMVH36	422
RWA6021	141	RWEA4231	142	RWHDHTB48H1	477	RWMVP24	422
RWA6023	141	RWEA4262	142	RWHDHTB48H2	478	RWMWT24	422
RWA6032	141	RWEA4813	142	RWHDHTB48H3	479	RWMWT30	422
RWA6612	141	RWEA4826	142	RWHDHTB48H4	480	RWMWT36	422
RWA6621	141	RWEA4831	142	RWHDHTB48H5	481	YPSB2024F	483
RWA6623	141	RWEA4862	142	RWHDHTB54H1	477	YPSB2024L	485
RWA6632	141	RWEA7220(L/R)	356	RWHDHTB54H2	478	YPSB2024LM	487
RWA7212	141	RWEA7224(L/R)	356	RWHDHTB54H3	479	YPSB2024V	489
RWA7221	141	RWEA7520(L/R)	365	RWHDHTB54H4	480	YPSB2027F	483
RWA7223	141	RWEA7524(L/R)	365	RWHDHTB54H5	481	YPSB2027L	485
RWA7232	141	RWEA(A/B/C/D/E/F/G)F3613	163	RWHDHTB60H1	477	YPSB2027LM	487
RWA(A/B/C/D/E/F/G)F4212	162	RWEA(A/B/C/D/E/F/G)F3626	163	RWHDHTB60H2	478	YPSB2027V	489
RWA(A/B/C/D/E/F/G)F4221	162	RWEA(A/B/C/D/E/F/G)F3631	162	RWHDHTB60H3	479	YPSB2030F	483
RWA(A/B/C/D/E/F/G)F4223	162	RWEA(A/B/C/D/E/F/G)F3662	163	RWHDHTB60H4	480	YPSB2030L	485
RWA(A/B/C/D/E/F/G)F4232	162	RWEA(A/B/C/D/E/F/G)F4213	163	RWHDHTB60H5	481	YPSB2030LM	487
RWA(A/B/C/D/E/F/G)F4812	162	RWEA(A/B/C/D/E/F/G)F4226	163	RWHDHTB66H1	477	YPSB2030V	489
RWA(A/B/C/D/E/F/G)F4821	162	RWEA(A/B/C/D/E/F/G)F4231	162	RWHDHTB66H2	478	YPSB2036F	483
RWA(A/B/C/D/E/F/G)F4823	162	RWEA(A/B/C/D/E/F/G)F4262	163	RWHDHTB66H3	479	YPSB2036L	485
RWA(A/B/C/D/E/F/G)F4832	162	RWEA(A/B/C/D/E/F/G)F4813	163	RWHDHTB66H4	480	YPSB2036LM	487
RWA(A/B/C/D/E/F/G)F5412	162	RWEA(A/B/C/D/E/F/G)F4826	163	RWHDHTB66H5	481	YPSB2036V	489
RWA(A/B/C/D/E/F/G)F5421	162	RWEA(A/B/C/D/E/F/G)F4831	162	RWHDHTB72H1	477	YPSB2042F	483
RWA(A/B/C/D/E/F/G)F5423	162	RWEA(A/B/C/D/E/F/G)F4862	163	RWHDHTB72H2	478	YPSB2042L	485
RWA(A/B/C/D/E/F/G)F5432	162	RWEAWF3613	180	RWHDHTB72H3	479	YPSB2042LM	487
RWA(A/B/C/D/E/F/G)F6012	162	RWEAWF3626	180	RWHDHTB72H4	480	YPSB2042V	489
RWA(A/B/C/D/E/F/G)F6021	162	RWEAWF3631	179	RWHDHTB72H5	481	YPSB2048F	483
RWA(A/B/C/D/E/F/G)F6023	162	RWEAWF3662	180	RWHDHTB78H1	477	YPSB2048L	485
RWA(A/B/C/D/E/F/G)F6032	162	RWEAWF4213	180	RWHDHTB78H2	478	YPSB2048LM	487
RWA(A/B/C/D/E/F/G)F6612	162	RWEAWF4226	180	RWHDHTB78H3	479	YPSB2048V	489
RWA(A/B/C/D/E/F/G)F6621	162	RWEAWF4231	179	RWHDHTB78H4	480	YPSB2054F	483
RWA(A/B/C/D/E/F/G)F6623	162	RWEAWF4262	180	RWHDHTB78H5	481	YPSB2054L	485
RWA(A/B/C/D/E/F/G)F6632	162	RWEAWF4813	180	RWHDHTB84H1	477	YPSB2054LM	487
RWA(A/B/C/D/E/F/G)F7212	162	RWEAWF4826	180	RWHDHTB84H2	478	YPSB2054V	489
RWA(A/B/C/D/E/F/G)F7221	162	RWEAWF4831	179	RWHDHTB84H3	479	YPSB2060F	483
RWA(A/B/C/D/E/F/G)F7223	162	RWEAWF4862	180	RWHDHTB84H4	480	YPSB2060L	485
RWA(A/B/C/D/E/F/G)F7232	162	RWEB7220(L/R)	356	RWHDHTB84H5	481	YPSB2060LM	487

<i>pattern no.</i>	<i>page</i>	<i>pattern no.</i>	<i>page</i>
YPSB2060V	489	YPSB3242F	483
YPSB2066FRR	483	YPSB3242L	485
YPSB2066L	485	YPSB3242LM	487
YPSB2066LM	487	YPSB3242V	489
YPSB2066V	489	YPSB3248F	483
YPSB2072FRR	483	YPSB3248L	485
YPSB2072L	485	YPSB3248LM	487
YPSB2072LM	487	YPSB3248V	489
YPSB2072V	489	YPSB3254F	483
YPSB2624F	484	YPSB3254L	485
YPSB2624L	486	YPSB3254LM	487
YPSB2624LM	488	YPSB3254V	489
YPSB2624V	490	YPSB3260F	483
YPSB2627F	484	YPSB3260L	485
YPSB2627L	486	YPSB3260LM	487
YPSB2627LM	488	YPSB3260V	489
YPSB2627V	490	YPSB3266FRR	483
YPSB2630F	484	YPSB3266L	485
YPSB2630L	486	YPSB3266LM	487
YPSB2630LM	488	YPSB3266V	489
YPSB2630V	490	YPSB3272FRR	483
YPSB2636F	484	YPSB3272L	485
YPSB2636L	486	YPSB3272LM	487
YPSB2636LM	488	YPSB3272V	489
YPSB2636V	490	YPSB3824F	484
YPSB2642F	484	YPSB3824L	486
YPSB2642L	486	YPSB3824LM	488
YPSB2642LM	488	YPSB3824V	490
YPSB2642V	490	YPSB3827F	484
YPSB2648F	484	YPSB3827L	486
YPSB2648L	486	YPSB3827LM	488
YPSB2648LM	488	YPSB3827V	490
YPSB2648V	490	YPSB3830F	484
YPSB2654F	484	YPSB3830L	486
YPSB2654L	486	YPSB3830LM	488
YPSB2654LM	488	YPSB3830V	490
YPSB2654V	490	YPSB3836F	484
YPSB2660F	484	YPSB3836L	486
YPSB2660L	486	YPSB3836LM	488
YPSB2660LM	488	YPSB3836V	490
YPSB2660V	490	YPSB3842F	484
YPSB2666FRR	484	YPSB3842L	486
YPSB2666L	486	YPSB3842LM	488
YPSB2666LM	488	YPSB3842V	490
YPSB2666V	490	YPSB3848F	484
YPSB2672FRR	484	YPSB3848L	486
YPSB2672L	486	YPSB3848LM	488
YPSB2672LM	488	YPSB3848V	490
YPSB2672V	490	YPSB3854F	484
YPSB3224F	483	YPSB3854L	486
YPSB3224L	485	YPSB3854LM	488
YPSB3224LM	487	YPSB3854V	490
YPSB3224V	489	YPSB3860F	484
YPSB3227F	483	YPSB3860L	486
YPSB3227L	485	YPSB3860LM	488
YPSB3227LM	487	YPSB3860V	490
YPSB3227V	489	YPSB3866FRR	484
YPSB3230F	483	YPSB3866L	486
YPSB3230L	485	YPSB3866LM	488
YPSB3230LM	487	YPSB3866V	490
YPSB3230V	489	YPSB3872FRR	484
YPSB3236F	483	YPSB3872L	486
YPSB3236L	485	YPSB3872LM	488
YPSB3236LM	487	YPSB3872V	490
YPSB3236V	489		



# Selling Policy

	<p>This Selling Policy supercedes all previous selling policies. Prices, discounts and product offerings are subject to change without notice.</p>
<b>Terms &amp; Conditions of Sales</b>	<p>Sales by Knoll, Inc. or Knoll North America Corp. ("Seller") of Knoll Product Lines (hereinafter "Products") within the United States and Canada are made only on the terms which are contained in this Selling Policy. Seller hereby gives notice of its objection to any different or additional terms and conditions. This sale is expressly conditional upon Purchaser's assent to the terms and conditions set forth below. Additional terms and conditions may apply to KnollStudio and KnollTextiles orders. These terms and conditions may be modified or supplemented only by a written document signed by an authorized representative of Seller. These terms and conditions supercede any prior and/or contemporaneous agreements or correspondence between Purchaser and Seller. Written quotations expire thirty (30) days from the date of issuance and can be withdrawn by written notice anytime during that period. Where Purchaser and Seller have entered into the Knoll Electronic Terms and Conditions, all orders, acknowledgements, invoices and other business communications placed or transmitted in accordance with the Knoll Electronic Terms and Conditions shall be deemed to be in writing and signed and shall be valid for all purposes as if they were originated and maintained in documentary form.</p>
<b>Ordering Information</b>	<p>All orders must be in writing. The product pattern number(s) contained on Seller's order acknowledgement shall be the final expression of the order.</p>
<b>Order Confirmation</b>	<p>A purchase order is not binding on Seller until Purchaser has received Seller's order confirmation or acknowledgment.</p>
<b>Pricing Policies</b>	<p>List prices are subject to change without notice.</p> <p>List prices shall be those prices in effect on the date of receipt of a complete purchase order unless shipment is requested more than ninety (90) days after order entry in which case prices in effect on the date of shipment apply. List prices include specified freight costs. Unless specified in writing by Seller, no other charges are included in Seller's list prices.</p>
<b>Taxes</b>	<p>All sales, use, excise and other taxes applicable to the sale of the Products shall be paid by Purchaser. If Purchaser claims an exemption from any tax, Purchaser shall submit to Seller the appropriate exemption certificates.</p>
<b>Terms of Payment</b>	<p>Payment for one hundred percent (100%) of the net order amount is due within thirty (30) days of the date of invoice, which is issued upon shipment. In case of any discrepancies, such as shortages, and Seller is notified in writing within ten (10) days of receipt of Product, only that portion may be deducted and the balance paid. For orders greater than \$100,000 net, a fifty percent (50%) deposit is due at the time of order placement, with the remainder due within thirty (30) days of the date of invoice.</p> <p>KnollStudio orders less than \$2,000 require payment for one hundred percent (100%) of the net order amount (including any applicable sales tax and charges for inside delivery, special packaging, etc.), due at time of order placement. For KnollStudio orders greater than \$2,000, a one-half (50%) deposit is due at time of order placement with the remainder (including any applicable sales tax and charges for inside delivery, special packaging, etc.) due prior to shipment.</p> <p>If, in the judgment of Seller, Purchaser's financial condition does not justify the terms of the payment, Seller may require full or partial payment in advance.</p> <p>Past due accounts shall be charged one and one-half percent (1.5%) per month, or the highest rate permitted by law, whichever is less, and will be added to the outstanding balance. In the event Purchaser defaults on payment, Purchaser shall be liable for all collection costs, including reasonable attorney's fees and costs.</p>
<b>Changes and Cancellation</b>	<p>Purchase orders may not be changed or cancelled, in whole or in part, without prior written consent of Seller. Changes may effect delivery dates. Expenses incurred because of changes shall be charged to Purchaser. In the event of cancellations, Purchaser will be liable for reasonable cancellation charges established by Seller. Orders for special Product, orders including "COM" (hereinafter defined) material and orders pursuant to expedited delivery programs, may not be canceled.</p>
<b>Freight Prepaid</b>	<p>Freight is prepaid and included in the price of all Products, except KnollTextiles, within the 48 contiguous United States for orders placed with Knoll, Inc. and within Canada, excluding the Yukon, Northwest Territories, Nunavut and Newfoundland for orders placed with Knoll North America Corp. Packing is tested for rigorous motion and transportation but is not guaranteed to protect furniture from conditions over which the Seller has no control. If special packaging is required for any reason, please consult with your sales representative or dealer. Seller shall select the method of shipment and routing. All shipments shall be tailgate deliveries. Freight for all KnollTextiles orders is prepaid and added to the invoice.</p>
<b>Delivery/Freight Charges</b>	<p>Shipments outside the contiguous 48 United States and Canada shall be shipped F.O.B. Origin.</p> <p>For shipments outside the contiguous United States and Canada, Purchaser is responsible for the cost of freight from point of embarkation, including any handling and transportation charges incidental to loading at the point of departure and unloading at the final destination.</p> <p>Conditions beyond the control of Seller, including weather, available facilities and traffic conditions, may affect exact time of delivery. Seller shall not be responsible for specific carrier delivery date or time unless it has made a specific delivery commitment, in writing.</p> <p>Nonstandard methods of shipment and/or additional services are available upon request. Purchaser will be billed for the differential cost of any special services in excess of standard surface carrier freight costs. Premium charges, at Purchaser's request, will be added for airfreight, exclusive use of vehicle and extra, export or special packaging. Accessorial charges will be added for inside delivery, extra labor, reassignment and redelivery.</p> <p>Partial shipments may be made and invoiced by Seller.</p>
<b>Claims</b>	<p>All shipments for all Knoll Products within the contiguous United States and Canada are F.O.B. Origin. Risk of loss passes to Purchaser at time of delivery to carrier. Purchaser shall inspect all Products upon receipt and notify Seller within ten (10) working days after receipt of any damage or defects which are, or should be, apparent from an inspection of the Product and its packaging. Failure of Purchaser to make a claim against carrier or notify Seller during the ten (10) working day period shall constitute acceptance of the Products and waiver of any apparent defects, errors or shortages. Seller will agree to repair or replace Product damaged in shipment if Purchaser has notified Seller of freight damage within ten (10) working days after receipt and assigns its rights against the carrier.</p>
<b>Seller's Security Interest</b>	<p>Until Seller receives the full payment for the Product, Seller shall have a security interest in the Product. Purchaser agrees to perform all acts, including but not limited to the execution and filing of documentation, which may be necessary to perfect and assure the security interest of Seller.</p>
<b>Returns</b>	<p>The return of Products without a written authorization by Seller shall not be accepted. To receive authorization for Product return, please call Customer Service. All Products that are returned pursuant to a valid authorization shall be subject to a twenty-five percent (25%) of list restocking charge. Products not currently offered for sale by Seller (including COM) shall not be authorized for return. All returned Products must be unused, in original condition and in the original Seller packing cartons. No refund or credit shall be given for damaged Products.</p>
<b>Held Orders/Storage</b>	<p>If Purchaser requests that an order be held or delayed, prices and terms and conditions in effect at the time of shipment shall apply. If Purchaser requests a delay after the time when Seller can defer production, Purchaser will be invoiced for the Product, payable in accordance with standard terms, when the order is ready for shipment. Seller may transfer the Product to storage, in which case all expenses incurred in connection with storage, including demurrage, preparation for storage, storage charges and handling shall be payable by Purchaser upon submission of invoices by Seller. Risk of loss to the Product shall pass to the Purchaser upon delivery of the Product into storage.</p>

# Selling Policy

<b>Customer's Own Material</b>	<p>A Purchaser who requests a fabric or other surface material not standard to Seller's line of Products ("COM") must submit samples of the requested material to Seller prior to entry of a purchaser order. Seller shall determine if the material is suitable to its manufacturing processes and meets any requirements of Underwriters Laboratories. If the COM is acceptable, Seller will then establish a price for using the COM or the Product in question. For a description of the procedures for submitting samples and testing, contact customer resources or your sales representative. Seller shall have no responsibility for the appearance, condition, performance, durability, colorfastness or any other physical attribute of the COM. Purchaser shall indemnify and hold Seller harmless for any damages, injuries or losses arising out of or related to use of the COM on the Product.</p>
<b>Warranty</b>	<p>Seller warrants to the original Purchaser only that the Products Seller manufactures and sells to Purchaser are free of defects in workmanship and materials, during the applicable warranty period set forth below.</p> <p>Warranty period set forth below is for 24-hour, 7 days a week, multi shift use (includes parts and labor to repair).</p> <p>Should any failure to conform with this limited warranty appear to a Product listed below during the applicable warranty period from the date of shipment, Seller shall, upon prompt written notice, repair or replace, at its option and costs, the affected part or parts.</p> <p><i>Product and Period of Warranty</i></p> <p><i>Lifetime: Antenna Workspaces, AutoStrada, Calibre, Crinion Open Table, Currents, Dividends Horizon, Equity, Morrison, Reff Profiles laminate, Series 2 Storage, Template, Antenna Workspaces and other non-wood components (except cascade edge worksurfaces, operational parts, controls, electrical, Lighting, Series 2 Veneer Front Storage, special or custom products, see below)</i></p> <p><i>12 Years: Chadwick, Essentials Work Chairs, Generation by Knoll, Life, Moment, MultiGeneration by Knoll, RPM and Sapper seating (except seating upholstery, textiles, leathers and finishes, see below).</i></p> <p><i>10 Years: Antenna Workspaces, AutoStrada, Crinion Open Table, Reff Profiles wood components, Series 2 Veneer Front Storage, cascade edge worksurfaces, Wood Casegoods (Magnusson, The Graham Collection) (except wood casegoods upholstered surfaces, see below), Interaction tables (except height adjustment mechanisms for Counterforce, crank-adjustable, and split-top tables and worksurfaces, see below), Reuter overheads, Reuter vertical storage, KnollExtra Sapper Monitor Arm Collection, Adjustable keyboard mechanisms and platforms, Communication Boards (except fabric board textiles, see below), Smokador collection (except leathers, see below), and Orchestra Universal Systems Accessories.</i></p> <p><i>5 Years: Operational parts, controls, electrical, Lighting (except light ballasts, bulbs and power supply, see below), special or custom product, wood veneer products, Currents handcrank, Interaction Counterforce, Interaction crank-adjustable, and split-top mechanisms, KnollStudio, CPU storage and all universal storage drawers.</i></p> <p><i>3 Years: Seating upholstery, textiles, leathers and finishes. Fabric boards textiles and Smokador Collection leathers.</i></p> <p><i>2 Years: All other KnollExtra product</i></p> <p><i>1 Year: Light ballasts, bulbs and power supply, seating upholstered armpads and soft armpads, wood casegoods upholstered surfaces.</i></p> <p>This warranty does not apply to:</p> <ul style="list-style-type: none"><li>• Damage caused by a carrier other than the Seller.</li><li>• Normal wear and tear or acts or omissions of parties other than Seller (including user modification, improper use or installation of Products).</li><li>• COM or other third party materials applied to Products.</li><li>• Products not installed by or under the auspices of a Knoll Dealer.</li><li>• Dramatic temperature variations or exposure to unusual conditions.</li><li>• Changes in surface finishes, including colorfastness due to aging or exposure to light.</li><li>• Except as specifically noted above, textiles and upholstery supplied by <i>KnollTextiles</i> (consult current <i>KnollTextiles</i> price list for applicable warranty).</li></ul> <p>Natural variations occurring in wood, marble, and leather shall not be considered defects, and the Seller does not guarantee the colorfastness or matching of the colors, grains or textures, or surface hardness of such materials. The Seller also does not guarantee the colorfastness of fiberglass panel surfaces.</p> <p>THE EXPRESS WARRANTIES CONTAINED HEREIN ARE IN LIEU OF ALL OTHER WARRANTIES, EXPRESS OR IMPLIED, INCLUDING ANY WARRANTIES OF MERCHANTABILITY AND FITNESS FOR PARTICULAR PURPOSE AND ALL OTHER WARRANTIES ARISING FROM COURSE OF DEALING OR USAGE OF TRADE.</p> <p>The remedies provided above are the Purchaser's sole remedies for any failure of Seller to comply with its obligations regarding the workmanship of its Products. Correction of any nonconformity in the manner and for the period of time provided shall constitute complete fulfillment of all liabilities of Seller, with respect to or arising out of the Product furnished hereunder.</p>
<b>Delay/Force Majeure</b>	<p>Seller shall not be liable for failure to perform or for delay in performance due to fire, flood, strike or other labor difficulty, act of God, act of any governmental authority or of the Purchaser, riot, embargo, fuel or energy shortage, wrecks or delay in transportation, inability to obtain necessary labor, materials or manufacturing facilities from usual sources or failure of suppliers to meet their contractual obligations, or due to any cause beyond its reasonable control. If any such event occurs, Seller may extend delivery dates by a period of time necessary to overcome the effect of such delay, allocate available Product or cancel any purchase order.</p>
<b>Compliance with Law</b>	<p>PURCHASER IS SOLELY RESPONSIBLE FOR COMPLIANCE WITH ALL APPLICABLE FEDERAL, STATE AND LOCAL LAWS, ORDINANCES, REGULATIONS, RULES AND STANDARDS RELATING TO THE INSTALLATION, MAINTENANCE, USE AND OPERATION OF THE PRODUCTS.</p>
<b>Patents</b>	<p>Subject to the following provisions, Seller shall, at its own expense, defend or, at its option, settle any claim, suit or proceeding brought against the Purchaser, and/or its vendees, mediate and immediate, so far as based on an allegation that any Product or any part thereof furnished hereunder constitutes a direct or a contributory infringement of any claim of any patent of the United States or Canada. This obligation shall be effective only if Purchaser shall have made all payments then due hereunder and if Seller is notified promptly in writing and given authority, information and assistance for the defense of said claim, suit or proceeding. Seller shall pay all damages and costs awarded in such suit or proceedings so defended.</p> <p>The foregoing indemnity does not apply to the following:</p> <ul style="list-style-type: none"><li>• Products supplied according to a design other than that of Seller, and which is required by the Purchaser.</li><li>• Combination of the Product with another product not furnished hereunder unless Seller is a contributory infringer.</li><li>• Any settlements of a suit or proceeding made without Seller's written consent.</li></ul>
<b>Limitations of Liability</b>	<p><b>SELLER, ITS CONTRACTORS, AUTHORIZED DEALERS AND SUBCONTRACTORS OR SUPPLIERS OF ANY TIER SHALL NOT BE LIABLE TO PURCHASER FOR ANY SPECIAL, INDIRECT, INCIDENTAL OR CONSEQUENTIAL DAMAGES ARISING FROM A BREACH OF THIS AGREEMENT.</b></p> <p>Purchaser's remedies set forth herein are exclusive and the liability of Seller with respect to the breach of this agreement or any contract entered into between the parties pursuant hereto shall not exceed the price of the Product or part on which such liability is based.</p>

# KnollKey Lock Program

## KnollKey Lock Program General Information

Following is the KnollKey lock policy, applicable to all products.

Knoll furniture can be ordered keyed-alike or random keyed. Key-alike and random keying instructions cannot be mixed on any single order. Only one of the two instructions can be used on an individual order. When an order is submitted with mixed (key-alike and random) instructions, Knoll will release the order as key-alike only and lock cores will have to be specified separately.

### Key-alike

For the convenience of the user, furniture may be keyed alike at no charge. Write "Key-alike" in the description of your purchase order for any pedestal, overhead, file or other item you wish to have keyed alike.

Using the key-alike instructions, order cores and keys as line items on your purchase order. Do NOT submit a key-alike form. The Knoll East Greenville Lock Center will select key numbers from the standard range of K 001 - K 250. Key numbers will not be repeated unless over 250 sets are ordered. Lock cores keyed-alike will ship separately from the product, ready for field installation.

There is no charge for key-alike orders if placed with the furniture order.

**IF THE KEY-ALIKE ORDER IS NOT PLACED AT LEAST TWO WEEKS PRIOR TO THE FURNITURE SHIP DATE, A \$50 HANDLING CHARGE AND AIR FREIGHT CHARGES WILL APPLY.**

**If product is ordered and shipped random-keyed, additional lock cores for key-alike are billable.**

### Random-Keying

To specify product keyed-random, write "key-random" in the product description. Random-keyed product is shipped with the lock core factory installed. A shrouded key is included. Random means no effort has been made to match key numbers, or to make them different.

### Keys

A Knoll shrouded key is shipped with every lock core. 250 Key numbers are available. For numbers above 250, contact Custom Product Development. Additional keys and key blanks are available. See service parts for more information.

### Master Keying

Knoll locks can be controlled by means of a master key. There is no additional per-lock charge for master keying. A letter of approval from the client must accompany orders for master keys.

### Installing Lock Cores

Lock cores can be installed or removed in the field by using a change key. Cores must be in the unlocked position to be removed. See service parts for change key pattern number and pricing.

### Lock Distribution

All orders for key-alike lock cores/keys are packaged and shipped from the East Greenville Lock Center, regardless of where the pedestals, overhead, or other units are produced. Random keyed product will have cores factory-installed.

## How to Specify Key-Alike

Following is an example of how to specify key-alike for a cluster of 10 workstations.

**Step 1** - Using the project floorplan, count the number of locks in each workstation.

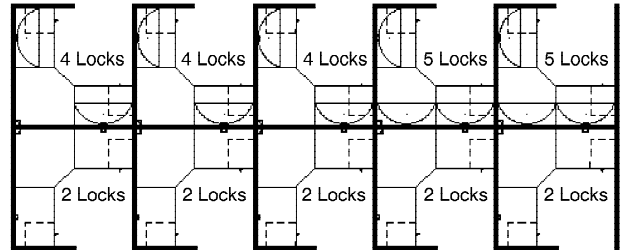

**Step 2** - Count the number of workstations with the same quantity of locks. Group together the workstations with a like number of locks.

5 workstations with 2 locks per station  
3 workstations with 4 locks per station  
2 workstations with 5 locks per station

**Step 3** - For the first group (5 sets of 2 locks), enter the number of workstations in the quantity column.

Qty	Pattern #	Description	Unit List	Ext. List
5				

**Step 4** - Then enter the pattern number "KSPEC\_ \_" and add a suffix for the number of locks for that group (i.e., for 2 locks per station, add the suffix "2"). Up to 30 lock cores are available in a set (i.e., KSPEC 30).

Qty	Pattern #	Description	Unit List	Ext. List
5	KSPEC 2	Set of 2 cores/keys	N / C	N / C

**Step 5** - Repeat for other groups.

Qty	Pattern #	Description	Unit List	Ext. List
5	KSPEC 2	Set of 2 cores/keys	N / C	N / C
3	KSPEC 4	Set of 4 cores/keys	N / C	N / C
2	KSPEC 5	Set of 5 cores/keys	N / C	N / C

Your Key instructions are complete.

Knoll will select key numbers for each set from 250 available numbers. Additional key numbers are available through Custom Product Development. **For additions to existing installations, specify desired key numbers in the description.**

## Service Parts

Pattern #	Description	List Price
KKEY_ _ _	Shrouded Key Specify key number desired	\$5
KBLANK	Shrouded Key Blank	\$5
KSPECB_ _ _	Retrofit Universal Core/Key Specify key number desired	\$18
KCHANGE	Change Key	\$5
KMASTER*	Master Key	\$5

\*Note: A letter of approval on company letterhead from the client must accompany all orders for master keys.

# General Ordering Information

---

## **The Products**

This guide encompasses all standard products for this product group.

## **Sizes**

Dimensions listed in this guide are indicated as:

H = height

W = width

D = depth

Dia. = diameter

Rad. = radius

## **Pricing**

All prices shown are list.

## **How to Order**

Select pattern numbers and quantities required for your complete installation. Product questions can be addressed in the specific sections of this guide or by contacting your sales representative or customer resource representative at 1-800-343-5665.

Next, select options (if required), along with colors and finishes appropriate to each product. Reference the Finishes and Fabrics pages for color designations.

On large installations, an item's "designated area" can be specified to assist in product organization and handling.

To expedite complete / correct entry of your order, be certain all pattern numbers, quantities, colors and area identifications are completely specified. Also, include complete purchase order numbers, bill-to and ship-to addresses, a contact name and specific factory shipping dates required.

## **Mail all orders to:**

Knoll, Inc.

1235 Water Street

P.O. Box 157

East Greenville, PA 18041

Attention: Order Entry

Once your order is entered at Knoll, an acknowledgment will be mailed to you. You will be advised of your scheduled shipping date within five days of the original acknowledgment. If it is necessary to revise your order, please contact your customer resource representative.

## Sustainability Statement

---

Sustainable design is a key component of Knoll's environmental focus. Our commitment to social responsibility and a healthy environment has prompted us to further articulate our longstanding environmental programs and, with encouragement and support from our colleagues in the industry, we have re-energized our focus on such "green" initiatives as life cycle analysis and LEED™ certification. Knoll is proud to have contributed to projects that have received LEED certification from the U.S. Green Building Council.

For the latest information on Knoll products that help our customers achieve LEED certification, log on to [knoll.com](http://knoll.com), click on "About Knoll" and then "Environmental Focus."