

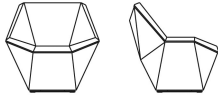













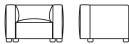



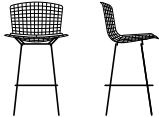
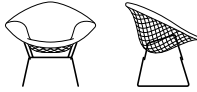



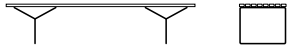
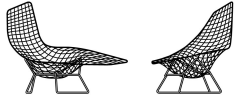
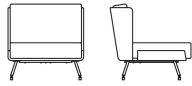
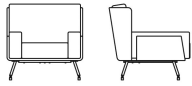
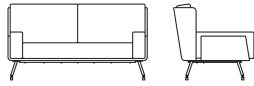
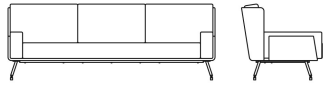
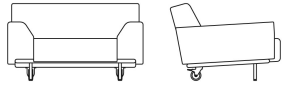
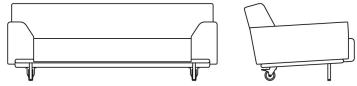



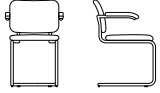
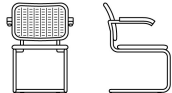
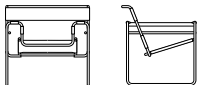



Introduction	Designer Index	3
	Visual Index	5
	Using the KnollStudio Price List	16
	Spinneybeck Leather Grades	17
	Upholstery Notes	18
	🔥 California Technical Bulletin 133	19
	Knoll and Sustainable Design	22
	GREENGUARD™ Certified KnollStudio Products	23
	KnollStudio Finish Code Chart: Compatibility with Knoll Office Systems	25
	Materials and Finishes	26
	Product Maintenance	28
	📄 KnollStudio 20-Day Program	30
	📄 KnollStudio 20-Day Program Upholstery Scope	30
	📄 Items Available on KnollStudio 20-Day Program	31
	Placing Your KnollStudio Order	33
Side Chairs and Lounge Seating	David Adjaye : The Washington Collection for Knoll™	34
	Edward Barber & Jay Osgerby : Sofa Collection	38
	Edward Barber & Jay Osgerby : Piton™ Stools	44
	Harry Bertoia : Side Chair	46
	Harry Bertoia : Two-Tone Side Chair	48
	Harry Bertoia : Barstools	50
	Harry Bertoia : Diamond Lounge Seating	54
	Harry Bertoia : Two-Tone Diamond Chair	56
	Harry Bertoia : Bird Lounge Chair and Ottoman	58
	Harry Bertoia : Asymmetric Chaise	60
	Harry Bertoia : Bench	62
	Pierre Beucler and Jean-Christophe Poggioli: Contract Lounge Seating	64
	Pierre Beucler and Jean-Christophe Poggioli: Residential Lounge Seating	70
	Cini Boeri : Lounge Collection	82
	Marcel Breuer : Cesca Chair	86
	Marcel Breuer : Wassily Chair	90
	Don Chadwick : Spark® Series	92
	Pepe Cortés : Jamaica Barstool	96
	Jonathan Crinion : Crinion Chair	98
	Joseph Paul D'Urso : Contract Lounge Seating	100
	Joseph Paul D'Urso : Residential Lounge Seating	104
	Joseph Paul D'Urso : Swivel Lounge Seating	108
	Raul de Armas : de Armas Chair	110
	Raul de Armas : Vertical de Armas Chair	116
	Frank Gehry : Side and Dining Chairs	120
	Frank Gehry : Lounge Seating	122
	Markus Jehs and Jürgen Laub : Jehs+Laub Lounge Collection, pedestal base	124
	Markus Jehs and Jürgen Laub : Jehs+Laub Lounge Collection, wire base	126
	Florence Knoll : Lounge Seating	128
	Knoll Design : k.™ lounge Collection	130
	KnollStudio : Throw Pillows	136
	Antti Kotilainen : CHIP Chair and Barstool	138
	Marc Krusin : Guest Seating Collection	140
	Maya Lin : Stones	146
	Piero Lissoni : Divina® Lounge Seating	152
Ross Lovegrove : Sprite Armless Chair	158	
Ross Lovegrove : Sprite Arm Chair	160	
Ross Lovegrove : Sprite Medium and Small Armless Chair	162	
Vico Magistretti : Cirene Stacking Chair	164	
Marco Maran : Gigi® Arm Chair	166	
Marco Maran : Gigi® Armless Chair	170	
Marco Maran : Gigi® Armless Chair with Sled Base	174	



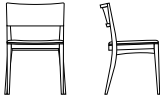
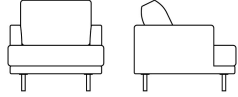
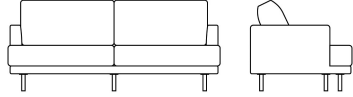
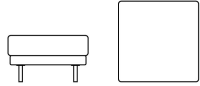
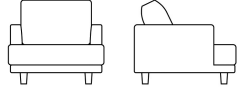
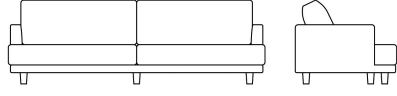
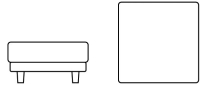
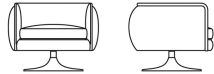
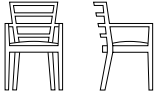
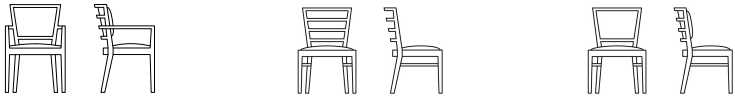
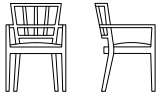
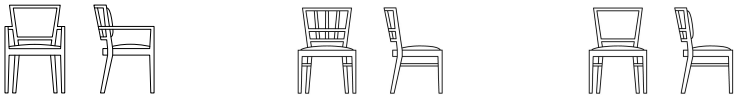
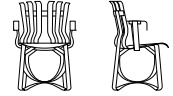
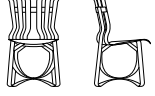
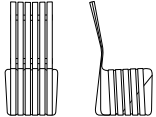

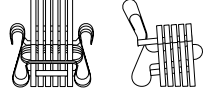
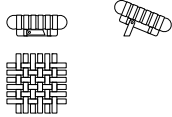





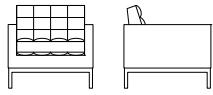
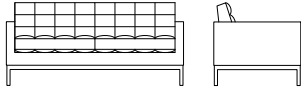
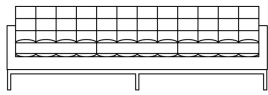
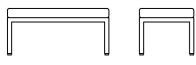
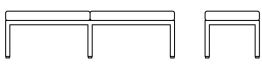
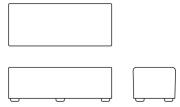
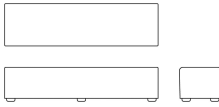
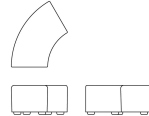
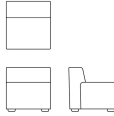
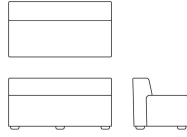
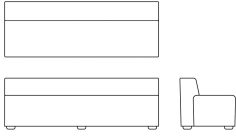
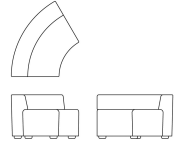
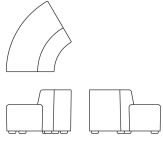

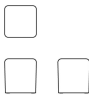
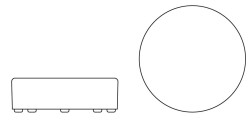

Side Chairs and Lounge Seating (cont'd.)	Marco Maran : Gigi® Barstool and Swivel Chair	178
	Marco Maran : X3 Chair and Barstool	180
	Ludwig Mies van der Rohe : Tubular Brno Chair	182
	Ludwig Mies van der Rohe : Flat Bar Brno Chair	184
	Ludwig Mies van der Rohe : Four Seasons Stool	186
	Ludwig Mies van der Rohe : MR Lounge Seating	188
	Ludwig Mies van der Rohe : MR Chair	190
	Ludwig Mies van der Rohe : Barcelona® Lounge Seating	192
	Ludwig Mies van der Rohe : Krefeld™ Collection	194
	George Nakashima : Straight Chair	200
	Jonathan Olivares : Aluminum Stacking Chair	202
	Jorge Pensi : Toledo Stacking Chair	204
	Charles Pfister : Petite Lounge Seating	206
	Charles Pfister : Lounge Seating	210
	Charles Pfister : Sofa System	212
	Warren Platner : Seating Collection	214
	Warren Platner : Easy Chair and Ottoman	216
	Charles Pollock : Executive Conference Arm and Armless Chairs	218
	Charles Pollock : Arm Chair	220
	Carlos Riart : Riart Rocker	222
	Joe Ricchio : Joe™ Chair	224
	Joe and Linda Ricchio : JR® and Ricchio Chair with Upholstered Seat	226
	Joe and Linda Ricchio : Fully Upholstered Ricchio and JR® Chairs	230
	Jens Risom : Side Chairs and Stool	236
	Jens Risom : Child's Side Chairs and Stool	238
	Jens Risom : Lounge Chairs	240
	Eero Saarinen : Tulip Chairs	242
	Eero Saarinen : Executive Arm Chairs	244
	Eero Saarinen : Executive Armless Chairs	248
	Eero Saarinen : Womb Chair, Ottoman and Settee	252
	Richard Schultz : 1966 Collection® Dining Chairs	260
	Richard Schultz : 1966 Collection® Barstools	262
	Richard Schultz : 1966 Collection® Lounge Seating	264
	Richard Schultz : 1966 Collection® Chaise Lounge Chairs	266
	Richard Schultz : Swell® Seating Collection	268
	Richard Schultz : Topiary® Seating Collection	270
	Richard Schultz : Fresh Air Dining Chair	272
	Shelton Mindel : Shelton Mindel Side Chair	274
	Shelton Mindel : SM1 Lounge Collection	276
	Shelton Mindel : SM2 Lounge Collection	278
	Stamberg Aferiat : Salsa® Lounge Seating	282
	Stamberg Aferiat : Salsa® Lounge Seating Shelf and Side Cushion Options	288
	Stamberg Aferiat : Salsa® Lounge Seating Specification Form	292
	Kazuhide Takahama : Suzanne Lounge Seating	294
	Ufficio Tecnico : Spoleto Chair	296
	Vignelli Associates : Handkerchief Armless Chair	298
	Vignelli Associates : Handkerchief Arm Chair	300
Tables/Executive Office	David Adjaye : The Washington Collection for Knoll™	302
	Franco Albini : Albini Desk	306
	Edward Barber & Jay Osgerby : Piton™ Side Table	308
	Marcel Breuer : Laccio Tables	310
	Joseph Paul D'Urso : Square Work and Low Tables	312
	Joseph Paul D'Urso : Round Work and Low Tables	314
	Joseph Paul D'Urso : Racetrack Work Tables	318
	Frank Gehry : Face Off Cafe Table	320
	Alexander Girard : Coffee Table	322
	Florence Knoll : Oval Table Desks	324
	Florence Knoll : Round Table Desk	326
	Florence Knoll : Executive Desk	328
	Florence Knoll : Credenzas	330
	Florence Knoll : Coffee Tables	334



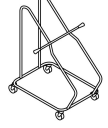
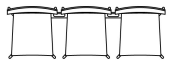







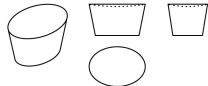

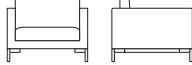
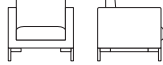
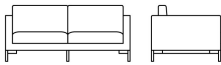
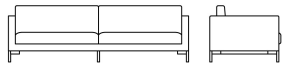





Tables/Executive Office (cont'd.)	Florence Knoll : End Tables	336
	Marc Krusin : Occasional Tables	338
	Ross Lovegrove : Table Desks	340
	Ross Lovegrove : Round Tables	342
	Ross Lovegrove : Tri-Oval Tables	344
	Ludwig Mies van der Rohe : Barcelona® Table, MR Table	346
	Ludwig Mies van der Rohe : Krefeld™ Side and Coffee Table	348
	Pascal Mourgue : Square and Rectangular Conference Tables	350
	Pascal Mourgue : Round and Racetrack Conference Tables	352
	Pascal Mourgue : Bullet Conference Tables	354
	George Nakashima : Splay-Leg Table and Tray	356
	Isamu Noguchi : Cyclone™ Dining and Side Tables	358
	Jorge Pensi : Pensi Tables	360
	Piironen : Arena Cafe Tables	364
	Warren Platner : Dining and Side Tables	366
	Warren Platner : Coffee Tables	368
	Jens Risom : Dining and Side Tables	370
	Jens Risom : Child's Amoeba Table	372
	Eero Saarinen : Round Dining Tables	374
	Eero Saarinen : Oval Dining Tables	378
	Eero Saarinen : Round End and Coffee Tables	380
	Eero Saarinen : Oval End and Coffee Tables	384
	Eero Saarinen : Outdoor Tables	386
	Richard Schultz : Petal® Table Collection	388
	Richard Schultz : 1966 Collection® Dining Tables	390
	Richard Schultz : 1966 Collection® Counter Height Tables	392
	Richard Schultz : 1966 Collection® Bar Height Tables	394
	Richard Schultz : 1966 Collection® End and Coffee Tables	396
	Richard Schultz : 1966 Collection® Serving Cart	400
	Richard Schultz : Fresh Air Dining Tables	402
	Richard Schultz : Topiary® Dining Tables	404
	Shelton Mindel : SM Tables	406
	Daniel Stromborg : Round Tables	408
	Daniel Stromborg : Square Tables	410
	Daniel Stromborg : Rectangular Tables	412
	Vignelli Associates : PaperClip™ Cafe Tables	414
Alpha-Numeric Index		415
Selling Policy		420
General Ordering Information		422

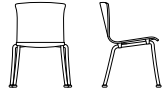
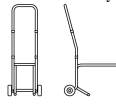





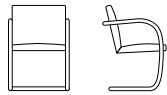
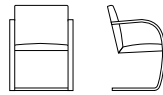

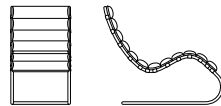
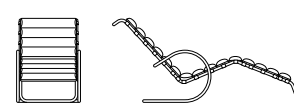
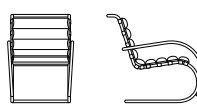
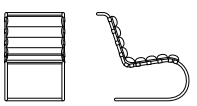
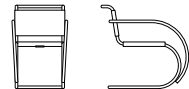
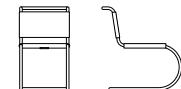

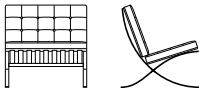

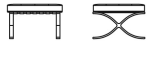

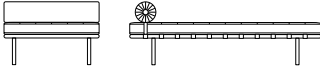
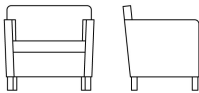
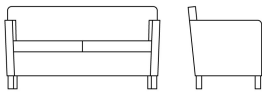
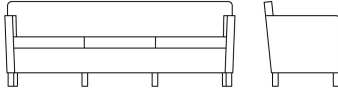

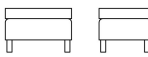
David Adjaye	34-37, 302-305
Franco Albini	306-307
Edward Barber & Jay Osgerby	38-43
Edward Barber & Jay Osgerby	44-45, 308-309
Harry Bertoina	46-63
Pierre Beucler & Jean-Christophe Poggioli	64-81
Cini Boeri	82-85
Marcel Breuer	86-91, 310-311
Don Chadwick	92-95
Pepe Cortés	96-97
Jonathan Crinion	98-99
Raul de Armas	110-119
Joseph Paul D'Urso	100-109, 312-319
Frank Gehry	120-123, 320-321
Alexander Girard	322-323
Markus Jehs and Jürgen Laub	124-127
Florence Knoll	128-129, 324
Knoll Design	130-135
Antti Kotilainen	138-139
Marc Krusin	140-145, 338-339
Maya Lin	146-151
Piero Lissoni	152-157
Ross Lovegrove	158-163, 340-345
Vico Magistretti	164-165
Marco Maran	166-181
Ludwig Mies van der Rohe	182-199, 346-349
Pascal Mourgue	350-355
George Nakashima	200-201, 356-357
Isamu Noguchi	358-359
Jonathan Olivares	202-203
Jorge Pensi	204-205, 360-363
Charles Pfister	206-213
Piironen	364-365
Warren Platner	214-217, 366-369
Charles Pollock	218-221
Carlos Riart	222-223
Joseph Ricchio	224-235
Linda Ricchio	226-235
Jens Risom	236-241, 370-373
Eero Saarinen	242-259, 374-387
Richard Schultz	260-273, 388-405
Peter Shelton & Lee Mindel	274-281, 406-407
Peter Stamborg & Paul Aferiat	282-291
Daniel Stromborg	408-413
Kazuhide Takahama	294-295
Ufficio Tecnico	296-297
Vignelli Associates	298
Vignelli Associates: David Law, Lella Vignelli & Massimo Vignelli	414-415



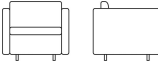
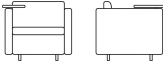
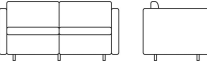
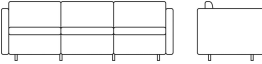

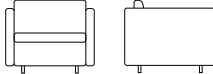
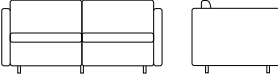

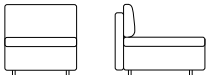

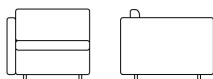



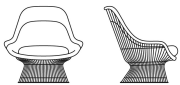





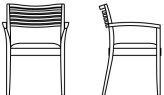

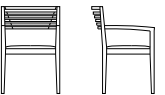
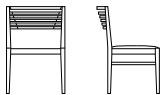
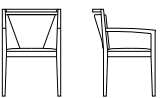
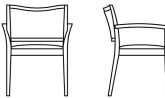

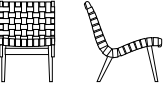

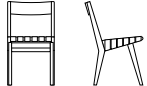
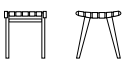





Page	SIDE CHAIRS AND LOUNGE SEATING				
34	ADJAYE	Prism™ Lounge chair 	Prism™ Ottoman 	Washington Skin™ 	Washington Skeleton™ 
38	BARBER & OSGERBY	Sofa 	Ottoman 	Arm chair 	Pillow 
		Piton™ stools 			
46	BERTOIA	Side chair 	Barstools 	Diamond chair 	Child's Diamond chair 
		Large Diamond chair 	Bird high back chair 	Ottoman 	Bench 
		Asymmetric Lounge 			
64	BEUCLER & POGGIOLI	Small lounge chair 	Lounge chair 	Settee 	Sofa 
82	BOERI	Lounge chair 		Sofa 	
		Ottoman 	Large pillow 	Small pillow 	
86	BREUER	Cesca chair 	Cesca chair, cane 	Wassily chair 	
92	CHADWICK	Spark side chair 	Spark lounge chair 		





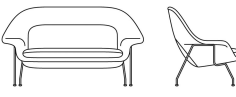



Page		SIDE CHAIR AND LOUNGE SEATING, continued			
96	CORTES	Jamaica Barstools	Jamaica low stool		
					
98 99	CRINION	Crinion arm chair	Crinion armless chair		
					
100 109	D'URSO	Contract Lounge chair	Small Sofa	Ottoman	
					
		Residential Lounge chair	Sofa	Ottoman	
					
		Swivel Lounge chair			
					
110 117	DE ARMAS	de Armas arm chairs	de Armas armless chairs		
					
		Vertical de Armas arm chairs	Vertical de Armas armless chairs		
					
120 123	GEHRY	Hat Trick arm chair	Hat Trick armless chair	High Sticking chair	Cross Check chair
					
		Power Play chair	Offside ottoman		
					
124 127	JEHS+LAUB	Lounge chair, pedestal base	Ottoman, pedestal base		
					
		Lounge chair, wire base	Ottoman, wire base		
					

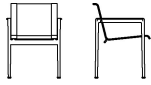

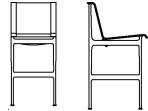
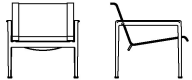
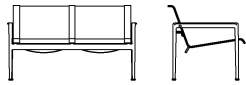
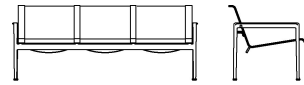
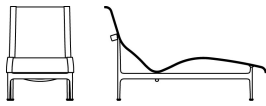
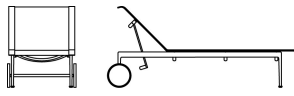
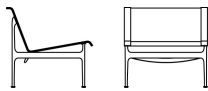
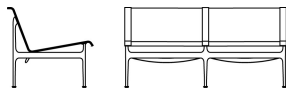
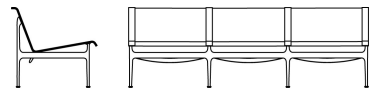



Page		SIDE CHAIR AND LOUNGE SEATING, continued			
128	KNOLL	Lounge chair 	Settee 	Sofa 	
		Two seater bench 	Three seater bench 		
130	KNOLL DESIGN	Bench, two seat 	Bench, three seat 	Bench, 48" inside radius, 60° 	Bench with back, single seat 
		Bench with back, two seat 	Bench with back, three seat 	60° Curved bench with back, inside radius 	60° Curved bench with back, outside radius 
		Ottoman 	Stool 	Pouf 	
136	KNOLLSTUDIO	Lumbar pillow 	Throw pillow 	Large throw pillow 	
138	KOTILAINEN	CHIP armless chair 	CHIP arm chair 	CHIP barstools 	Dolly 
		Ganging mechanism 			
140	KRUSIN	Arm chair 	Arm chair with inset 	Armless chair 	Armless chair with inset 
		Arm lounge 	Armless lounge 		

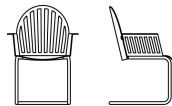
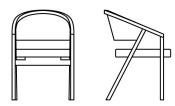
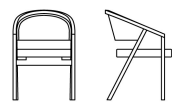
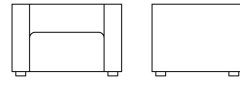
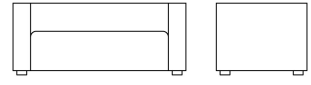
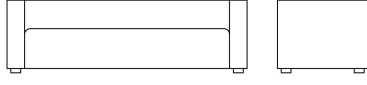
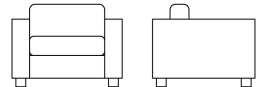
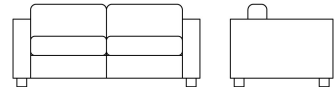
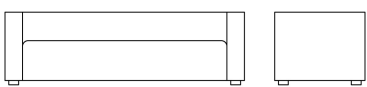

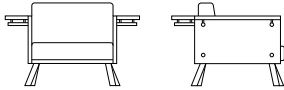
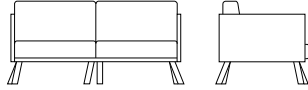
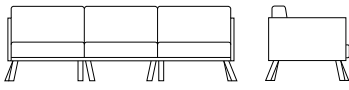

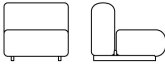

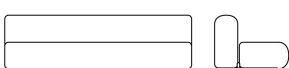
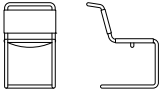
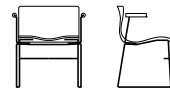





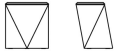







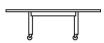

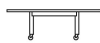

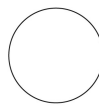
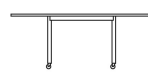



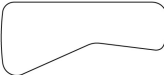

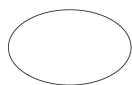

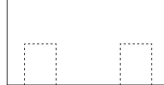
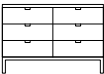
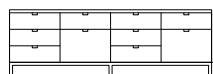

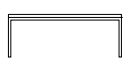



Page		SIDE CHAIR AND LOUNGE SEATING, continued			
146	LIN	<p>Adult stones</p> 	<p>Child stones</p> 	<p>Stones Coffee table</p> 	
152	LISSONI	<p>Divina Lounge chair</p> 	<p>Petite Lounge chair</p> 	<p>Settee</p> 	<p>Sofa</p> 
		<p>Ottoman</p> 			
158	LOVEGROVE	<p>Sprite armless chair</p> 	<p>Sprite arm chair</p> 	<p>Sprite Dolly</p> 	<p>Sprite medium armless chair</p> 
		<p>Sprite small armless chair</p> 			
164	MAGISTRETTI	<p>Cirene arm stacking chair</p> 	<p>Cirene armless stacking chair</p> 	<p>Cirene Dolly</p> 	
180	MARAN	<p>Gigi arm chair</p> 	<p>Gigi armless chair</p> 	<p>Gigi Barstools</p> 	<p>Gigi Swivel chair</p> 
		<p>X3 Stacking chair</p> 	<p>X3 Barstools</p> 		
182	MIES VAN DER ROHE	<p>Tubular Brno chair</p> 	<p>Flat Bar Brno chair</p> 	<p>Four Seasons stool</p> 	
		<p>MR Chaise lounge</p> 	<p>MR adjustable chaise lounge</p> 	<p>MR arm lounge chair</p> 	<p>MR armless lounge chair</p> 
		<p>MR arm chair</p> 	<p>MR armless chair</p> 		

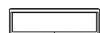



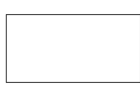

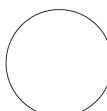

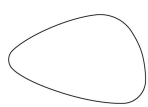

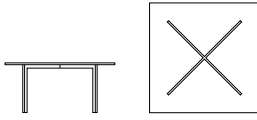

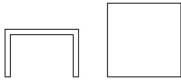
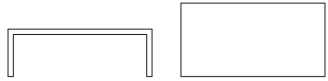
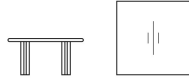
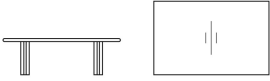

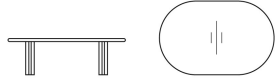

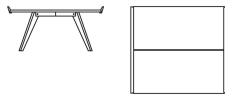

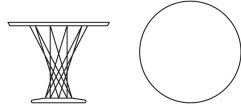

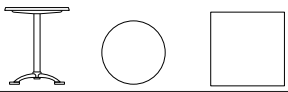
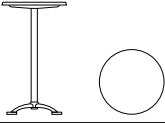
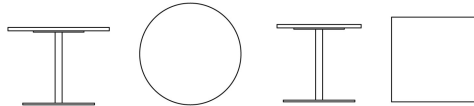
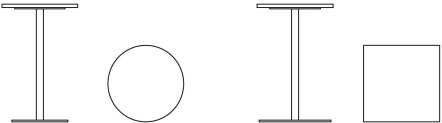
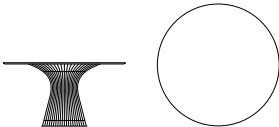
Page		SIDE CHAIRS AND LOUNGE SEATING, continued			
192	MIES VAN DER ROHE	Barcelona chair 	Child's Barcelona chair 	Barcelona stool 	Child's Barcelona stool 
		Barcelona stool with cowhide sling 	Barcelona couch 		
		Krefeld Lounge chair 	Krefeld Settee 	Krefeld Sofa 	
		Krefeld medium and large benches 		Ottoman 	
200	NAKASHIMA	Straight chair 			
202	OLIVARES	Olivares chair 			
204	PENSI	Toledo chair 	Toledo chair seat cushion 		
206	PFISTER	Petite Lounge chair 	Petite Lounge chair with tablet arm 	Petite Settee 	Petite Sofa 
		Petite Ottoman 	Lounge chair 	Settee 	Sofa 
		Ottoman 	Modular Sofa System Center module 	End modules 	Corner module 

Page	SIDE CHAIRS AND LOUNGE SEATING, continued						
214	PLATNER	Lounge chair	Arm chair	Stool	Easy chair	Ottoman	
							
218	POLLOCK	Executive Conference arm chair	Executive Conference armless chair			Arm chair	
							
222	RIART	Riart Rocker					
							
224	RICCHIO	Joe arm chair	JR chair	Ricchio arm chair	Ricchio armless chair		
							
		Ricchio Fully upholstered chair		JR Fully upholstered chair			
							
236	RISOM	Lounge chairs		Side chairs			
							
		Sitting stool	Child's Side chairs		Child's Sitting stool		
							
242	SAARINEN	Tulip arm chair	Tulip armless chair	Stool			
							
244	SAARINEN	Executive arm chair	Executive armless chair	Arm chair	Armless chair		
							
252	SAARINEN	Womb chair	Ottoman	Womb Settee	Medium Womb chair		
							
		Medium Ottoman	Child's Womb chair				
							

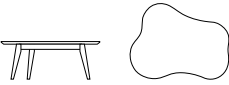

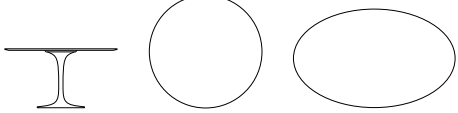

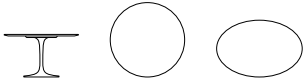





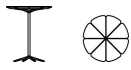
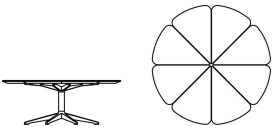
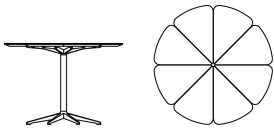
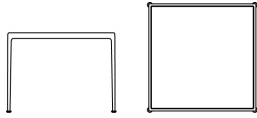
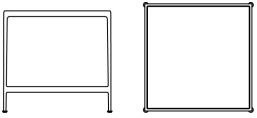
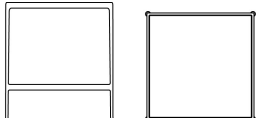
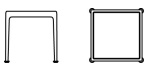

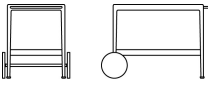
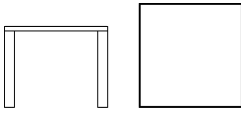
Page		SIDE CHAIRS AND LOUNGE SEATING, continued			
260	SCHULTZ	Dining chair with arm 	Dining chair, armless 	Counter height armless barstool 	Bar height armless barstool 
		Lounge chair with arms 	Two seat lounge chair with arms 	Three seat lounge chair with arms 	
		Contour chaise lounge 	Adjustable chaise lounge 		
		Single seat club chair 	Two seat sofa 	Three seat sofa 	
		Topiary dining chair 	Topiary lounge chair 	Topiary bench 	Topiary small ottoman/end table 
		Topiary stacking chair 	Fresh Air dining chair 		
274	SHELTON & MINDEL	SM side chair 	SM side chair, fully upholstered 		
		SM1 Lounge chair 	SM1 Settee 	SM1 Sofa 	
		SM2 Lounge chair 	SM2 Settee 	SM2 Sofa 	

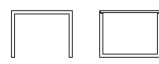
Page	SIDE CHAIRS AND LOUNGE SEATING, continued				
282	STAMBERG AFERIAT	Salsa Lounge chair	Salsa Settee		
					
		Salsa Sofa	Salsa Shelves		
					
294	TAKAHAMA	Suzanne lounge chair	Double lounge chair	Settee	Sofa
					
296	TECHNICO	Spoleto chair			
					
298	VIGNELLI ASSOCIATES	Handkerchief arm chair	Handkerchief armless chair		
					

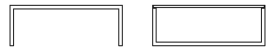
Page	TABLES / EXECUTIVE OFFICE			
302	ADJAYE	Washington Corana™	Prism™ side tables	
				
306	ALBINI	Pedestal desk		
				
308	BARBER & OSGERBY	PITON™ side tables		
				
310	BREUER	Laccio tables		
				
312	D'URSO	Work and low tables - Square	Work and low tables - Round	Work tables - Racetrack
				
				
				
320	GEHRY	Face Off café tables		
				
322	GIRARD	Coffee table		
				
324	KNOLL	Oval and Round table desks	Executive desk	
				
				
		Two Position Credenza	Four Position Credenza	Coffee and end tables
				
				
				
				
338	KRUSIN	Square side tables	Square end tables	Square coffee tables
				
				
				
				
				
				
340	LOVEGROVE	Rectangular tables	Round tables	Tri-Oval tables
				
				
				
				

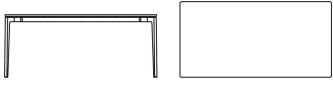
Page	TABLES / EXECUTIVE OFFICE				
346	MIES VAN DER ROHE	Barcelona table 	MR table 	Krefeld side table 	Krefeld coffee table 
350	MOURGUE	Pascal square table 	Pascal rectangular table 	Pascal round table 	Pascal racetrack table 
		Pascal bullet table 			
356	NAKASHIMA	Splay-leg table 	Tray 		
358	NOGUCHI	Cyclone dining table 	Cyclone side table 		
360	PENSI	Pensi tables 	Pensi high table 		
364	PIIROINEN	Arena tables 	Arena high tables 		
366	PLATNER	Dining table 	Side table 	Coffee tables 	
370	RISOM	Dining table 	Side tables 	Amoeba coffee table 	Child's Amoeba coffee table 
374	SAARINEN	Dining tables 	Side tables 	Coffee tables 	
		Outdoor tables 			

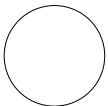
Visual Index

Page		TABLES / EXECUTIVE OFFICE, continued			
388	SCHULTZ	Petal end table	Petal coffee table	Petal dining table	
					
		1966 Dining table	1966 Counter Height table	1966 Bar Height table	1966 End table
					
		1966 Coffee table	1966 Serving Cart	Fresh Air Dining table	Topiary® Dining table
					
406	SHELTON & MINDEL	SM side table	SM small coffee table	SM large coffee table	SM square coffee table
					
408	STROMBORG	Round table	Square table	Rectangular table	
					
414	VIGNELLI ASSOCIATES	PaperClip tables			
					

A Price List Overview

Where do I send my order? How should I maintain my marble table? From textile options to wood polishes, the KnollStudio price list is designed to provide you with everything you need to know in order to understand, specify, and care for furniture in the KnollStudio Collection.

This book is divided into three easy-to-use sections.

- Side Chairs and Lounge Seating
- Tables and Executive Office
- Propeller Table Series

For a quick overview of the collection's scope, review the Visual Index on pages 5-0. If you're looking for pieces by a specific designer, try the Designer Index on page 4.

Need furniture in a hurry? KnollStudio 20-day on pages 30-31 highlights KnollStudio pieces available in only twenty days.

Leathers, Textiles, and Finishes

If you're confused about which leather to select, pages 17-18 explains the broad selection of Spinneybeck leathers available for KnollStudio furniture.

Additional upholstery notes and Customer's Own Material (COM) information are available on page 18.

For detailed explanations of the many materials used in constructing KnollStudio furniture, consult page 27. A cross-reference of KnollStudio veneer or lumber finishes with standard Knoll Office veneers is provided on page 25. Easy-care maintenance information is also provided on pages 28-29.

Placing Your KnollStudio Order

For information about where to send your order and key terms and conditions, see page 33. The complete Knoll Selling Policy is available on pages 420-421.

General Ordering Information and Knoll's Sustainability Statement is available on page 422

Product Information On Each Page

On each page, the following features will assist you:

Description provides both the pattern number and a basic description of the product.

Dimensions provide the overall space the product will require. Statistics are based on the maximum width, depth, and height of the product.

Weight is based on the product itself. It does not include packaging. Weights are rounded to the nearest pound.

Weights of upholstered items do not include weight of textile/leather. To calculate total weight, multiply covering requirements by textile/leather weight, and add to product weight.

Pattern Number provides both the product identification number and all additional selections required for ordering. Finish options are enclosed in parentheses. Finish suffix descriptions are found under Finishes on the bottom portion of the page.

Order Code/Ordering Information outlines exactly how to specify KnollStudio product and the full scope of finishes and other options. The Order Code provides an example of how one pattern number on the page is specified.

20-Day pieces available in 20 days ex-factory are noted with helicopters  next to the items. Additional information is provided under Ordering Information and in the 20-Day section of this book.

Construction provides specific materials and finishes employed, as well as specific construction details.

Textiles and Leather Grades list by price group all KnollTextiles and Spinneybeck Leathers approved for each seating piece. This list is derived through careful examination of the textile or leather's distinctive upholstery characteristics and the form and structure of each piece of furniture. KnollTextiles or

Spinneybeck leathers that are not listed have been rejected because Knoll cannot ensure their performance on that product. To view the full range of colorways available for each fabric or leather, consult any Knoll or Spinneybeck representative.

Cal 133 Technical Bulletin

Many KnollStudio products meet California Technical Bulletin 133. Information for specifying these items is on page 19. Items available are indicated with a flame . Applicable upcharge will be listed on the respective price list page.

Greenguard

Many KnollStudio products meet Greenguard environmental standards. Please see page 24 for a complete listing of products.

CPSIA Testing

Many knoll kids products meet the consumer Product Safety Improvement Act of 2008 for Children's Products, 16 C.F.R. 1303 CPSIA Title 1 Section 101 for Total Lead in Substrates and Surface Coatings. For a complete listing of approved products, please refer to individual price list pages.

Note to Knoll Dealer Sellers:

The products contained in this price list are also available through the Knoll Essentials program, with limited exceptions. For additional information, please contact your customer service representative or visit Knoll Exchange.

For More Information

For more information, contact your KnollStudio representative, a Knoll Space reailer or e-tailer, or telephone Customer Services at 800 343-KNOLL. To find the retailer or showroom nearest you, visit www.knoll.com.

For the ultimate in comfort, durability, and prestige, many KnollStudio products can be upholstered in Spinneybeck leathers.

Spinneybeck leathers are made from the top 2% of the world's finest hides, inspected numerous times during production to ensure evenness of grain, surface, color and the absence of scars.

After tanning, all Spinneybeck leathers are drum-dyed, a time-consuming procedure which ensures color penetration throughout the hide. Each hide is then finished in the manner which will best bring out its individual character.

Spinneybeck leathers are all full-grain aniline drum-dyed products imported from Italy.

The following Spinneybeck leathers are approved for application on KnollStudio products. Leathers are grouped into five price categories referred to as "grades." The selection of approved leathers varies by product. Please refer to the pricing page of each product line for more information.

Square footage requirements for Customer's Own Leather (COL) are listed on the left side of the pricing page. Please refer to Upholstery Notes on page 18 and The Knoll Selling Policy on pages 420-421 for further information regarding COL.

For further information call Spinneybeck at 1-800-482-7777.

Grades

U

Vicenza
Volo

Characteristics

Heavily finished cowhide, corrected grain, slightly raised grain texture
Heavily finished cowhide, corrected grain, slightly raised grain texture

V

Acqua
Andes
Embossed
Tipped
España
Hand Tipped
Maremma
Velluto Pelle

Heavy water-repellent finished kip, corrected grain, slightly raised grain texture
Slightly pronounced grain cowhide with a medium finish, and enhanced grain
Lightly finished cowhide, full grain, embossed pronounced pebble grain
Smooth, tight grain cowhide; breathable, protective medium finish, enhanced grain
Two-toned leather, lightly finished cowhide, pronounced pebble grain texture
Full grain textured suede with impregnated soil-resistant treatment
Slightly pronounced grain cowhide with a medium finish, enhanced grain

W

Alaska
Amazon
Antique
Arizona
Derby
Forte
Lucente
Sabrina

Pearlized-iridescent protective finish cowhide, full grain with smooth texture
Mid-weight, full grain cowhide; colors of the Amazonian jungle, raised grain texture
Smooth tight grain cowhide, lightly antiqued to produce an elegant patina, enhanced grain
Full grain, lightly finished kip; ironed for tight, smooth texture, glove-like hand
Combination-tanned cowhide; full grain, medium finish and raised grain texture
High performance, full grain leather with slightly pronounced grain texture
Smooth, very tight grain cowhide; subtle sheen; light casein finish
Smooth, tight and full grain kip with a breathable protective finish

X

Ducale
Ducale
Velour

Embossed shrunken grain cowhide, medium protective finish, full grain
Full grain-sueded cowhide, embossed shrunken grain, scotch-guarded

Y

Capri
Cervo
Copenhagen
Cordovan
Distressed
Lucca
Marissa
Portofino
Prima
Riva
Saddle
Salon
Torello

Chrome-free, light protective finish, full grain cowhide
Full aniline, pronounced grain texture, soft luxurious hand
Full aniline, 100% vegetable tanned leather, full grain
Aniline-dyed cowhide, light waxy finish, supple hand, full grain
Aniline-dyed, paraffin wax final ironing process with a smooth finish, and full grain
Aniline-dyed, pebble grain sueded leather
Grain-sueded cowhide, scotch-guarded smooth suede grain
Full grain, lightly finished cowhide, with a pronounced raised texture
Full aniline, special oils provide a very elegant and supple hand
Slightly pronounced grain texture, water-repellent, full grain
Full aniline, smooth very tight grain surface takes on a rich patina over time
Full aniline cowhide, ironing process provides a lustrous sheen of traditional leathers
Full grain, aniline dyed, natural shrunken bovine leather; light protective finish

Textile and Leather Notes

All seating in this price list includes the cost of applied fabric or leather. To simplify ordering, the seating is arranged into specific upholstery grades and priced accordingly. Samples and prices of cut textiles are available on request. For a full list of the Spinneybeck leathers available, see page 17.

Leather*The Natural Qualities of Leather*

Natural leather is unique. Because every animal is different, each hide has its own individual color, texture, and life-marks. In fact, our leathers are painstakingly treated to retain their natural appearance and hand. Range marks are not camouflaged. Colors and texture vary, and will do so more with age as the leather mellows and takes on a rich patina.

Spinneybeck Leathers

Spinneybeck offers full-grain Italian leathers.

Spinneybeck features three different tanning processes which preserve the leather. The first is mineral tannage, in which chromium salts are used; the second is vegetable tannage, in which bark tanning is used; and the third is a combination of the first two processes. Each leather is tanned in the manner which will best accentuate its unique characteristics.

Spinneybeck leathers are drum-dyed which tumbles the leather over and over for smooth, even coloring absorbed directly into the leather. This aniline-dyeing process enhances the natural qualities of leather grain. Many competitors use vat-dyeing. This does not dye the leather in an even manner.

If you have further questions on Spinneybeck leathers, contact your Knoll representative or telephone Spinneybeck Customer Service at 1-800 482-7777.

Below are additional details on the three major types of Spinneybeck leathers.

Naked Leather (Capri, Copenhagen, Cordovan, Distressed, Maremma, Prima, Saddle) Naked leather contains no foreign substances which would affect the superbly soft, mellow hand of this most luxurious of upholstery leathers. Natural markings are

accentuated. Since there are no barriers against spillage or staining, naked leathers should be carefully specified. However, scratches and marks will dissipate in time as the leather develops a beautiful patina.

Leathers with Protective Finishes:

(Acqua, Alaska, Amazon, Andes, Antique, Arizona, Derby, Ducale, España, Forte, Hand Tipped, Lucente, Montalcino, Portofino, Riva, Sabrina, Salon, Velluto Pelle, Volo)

For high traffic areas, protective finishes allow leather to be not only practical, but easy to maintain.

Grain Sueded Leathers (Ducale Velour, Marissa)

Full grain leathers that have been lightly buffed to raise the nap of the surface are referred to as "grain sueded" leathers. This produces the soft hand of sueded leathers. For maximum soil resistance and durability, these leathers have received an impregnated soil resistance treatment during the drum-dye process which permeates the leather, making it repellent to liquid and dirt.

Textile*Classic Boucle*

Classic Boucle is with spun Boucle yarn that is a blend of wool and nylon that is piece dyed. Color can vary from lot-to-lot and it is important to use the same lot for multiple piece orders. Please notate sales order when items must match. Classic Boucle, Pearl contains natural, un-dyed wool and will have darker hairs woven within the textile.

Knoll Upholstery Restrictions

Every Knoll leather and fabric is exhaustively tested on each Knoll upholstered item. This is done in addition to the most extensive program of independent fabric testing in the industry. On furniture, testing ensures precise fit and appearance, without stretch, puddling, telegraphing or other common problems frequently experienced when careful factory pre-qualification is eliminated.

When Knoll suggests that a particular leather or fabric not be used on an object, this does not mean the material is defective in any way; it only implies less than perfect performance with the form and structure of a specific item on furniture.

Instructions for Ordering Nano-Tex

The minimum for Nano-Tex on KnollStudio orders is 1-lot of \$206 net for up to 65 yards. Nano-Tex orders of 65 yards or more is \$3.00 net/yard.

Dealer instructions for ordering Nano-Tex:

- 1) Visit knolltextiles.com/technical documents and open the Nano-Tex specifications to see if the fabric is approved with the finish.
- 2) If approved, check the seating matrix at knolltextiles.com to see if the fabric alone is approved on the chair. (If yes, proceed to #3).
- 3) Contact your account manager with the fabric name, treatment required, and name and pattern number of desired chair. They will see if Knoll has tested this fabric with finish/treatment on said chair. In most cases, application testing has not been done and they will contact the appropriate parties to initiate approval and determine leadtime for testing.
- 4) If approved, book order with a suffix of N (for Nano-Tex) after the fabric pattern number.
- 5) The fabric grade will remain the same. Add line item for finish/treatment required and multiply the finish cost by the number of yards required.

Customer's Own Material (COM)**Customer's Own Leather (COL)**

While Knoll is pleased to cooperate with COM/COL selections, an extra charge is required to help offset receiving and handling costs. Such charges are included under the COM/COL title of the price columns in this price list. Prior to order placement, a sample cutting of actual COM/COL must be submitted to Knoll in East Greenville or through your regional Knoll office for preliminary approval of intended item (8' x 8" minimum memo sample if solid; if COM has a repeat, the sample must be large enough to show the repeat).

Even after such preliminary approval, Knoll reserves the right to reject COM/COL, including, if necessary, the item intended for use with COM/COL, if Knoll considers the customer-supplied material inadequate for any reason. When COM/COL is accepted, KnollStudio assumes no responsibility for its appearance, durability, color fastness or any other quality after upholstered on a Knoll product.

Published yardage requirements are based upon Knoll 52" width material unless specified otherwise. Leather requirements are based on whole hides with a minimum of 50 square feet per hide. However, in some cases, the nature or pattern of COM/COL will require additional yardage/square feet and/or additional labor charges. When this is necessary, the customer will be notified at the same time that the preliminary sample is approved.

If your COM/COL is approved, you may send the required amount for the product to:

Knoll, Inc.
1235 Water St
East Greenville, PA 18041
Attn: Customer Resources

COM/COL must be marked with designated approval number and customer's name.

For additional information, see Customer's Own Material (COM) under Selling Policy on pages 420-421.

Test Objective

California Technical Bulletin 133 (Cal 133) is a full-scale seating test, not a component test. Testing must be performed on the designated seating unit and textile together. Component data alone cannot be used to certify compliance with the regulation. Under Cal 133 you cannot assume that seating or textiles that have passed individually will pass together.

Test Procedure

The seating unit is exposed to a square open flame gas burner for 80 seconds, positioned at the center of the seating unit, two inches from the back and one inch from the seat.

Scope

Cal 133 only applies to seating units. The bulletin is designed for high risk public areas:

- Nursing homes
- Health care facilities
- Public auditoriums
- Hotels (more than 10 seating units in one room)
- Motels (more than 10 seating units in one room)
- Jails and prisons

Tables and desks are not covered by the bulletin. Variations may occur in individual states with regards to specific application. In California only, compliance is at the discretion of the fire marshal in any building which is fully sprinklered.

KnollStudio Approvals

Tested seating units have been tested in a worst case scenario thus covering other fabrics of lighter weight and same construction. When specifying Cal 133, the seating unit may be constructed with a fire resistant foam and a fire blocker will be laminated to the textile.

How To Specify

It is easy to specify Cal 133 on KnollStudio seating. Simply add the suffix “C” to the end of the pattern number prior to the textile selection. Approved textile selections must have the suffix 133 added to the end of the pattern number.

Example: Bertoia side chair, chrome, seat pad in Common Ground/Basalt 420C-C-K-C-K448/12-133

Testing Additional Product

If you would like to test a specific product:

Specify chair and textile desired - adding appropriate C and 133 codes as explained.

Testing lead time will be the standard lead time of the chair plus 4 - 6 weeks for testing procedure.

Test cost will be the regular price of the chair plus \$500 for the testing procedures.

Cal 133 tested and approved fabrics and seating units are indicated with a flame . All prices below are list.

KnollStudio CAL 133 Approved Products					
Designer	Product	Pattern #	Unupholstered, no upcharge	Knoll Textiles, upcharge	Spinneybeck leather, upcharge
Bertoia	Side Chair, seat cushion	420K	approved	approved, no upcharge	approved, no upcharge
Bertoia	Barstools, Bar Height, seat cushion	427K	approved	approved, no upcharge	approved, no upcharge
Bertoia	Barstools, Counter Height, seat cushion	428K	approved	approved, no upcharge	approved, no upcharge
Bertoia	Diamond Lounge Chair	421K	approved	approved, no upcharge	approved, no upcharge
Bertoia	Diamond Lounge Chair	421F	approved	approved, no upcharge	approved, no upcharge
Bertoia	Child’s Diamond Lounge Chair	421LS-K		approved, no upcharge	approved, no upcharge
Bertoia	Child’s Diamond Lounge Chair	421LS-U		approved, no upcharge	
Bertoia	Large Diamond Chair	422F		approved, no upcharge	
Bertoia	Bird Lounge Chair and Ottoman	423LU, 424YU		approved, no upcharge	
Bertoia	Asymmetric Chaise	429LU, 429F		approved, no upcharge	
Boeri	Lounge Chair	CB1		\$605.00	\$802.00
Boeri	Sofa	CB2		\$827.00	\$1,142.00
Boeri	Ottoman	CB3		\$352.00	\$642.00
Breuer	Cesca Chair	50A, 50C		\$90.00	
Breuer	Wassily Chair	50L	approved		approved
Chadwick	Spark Series	4-C-SD-S, 4-C-LG-S		\$58.00	
Cortes	Jamaica Barstool	30C	approved		
Crinion	Crinion Chair	58A, 58C		\$58.00	
D’Urso	Lounge Chair	2160, 2160R		\$579.00	\$677.00
D’Urso	Lounge Chair, split upholstery	2160S, 2160RS		\$881.00	\$881.00
D’Urso	Swivel Lounge Chair	2165		\$524.00	
D’Urso	Small Sofa	2161		\$1033.00	\$1,131.00
D’Urso	Small Sofa, split upholstery	2161S		\$1,358.00	\$1,358.00
D’Urso	Residential Sofa	2162R		\$1,262.00	\$1,358.00
D’Urso	Residential Sofa, split upholstery	2162RS		\$1,585.00	\$1,585.00
D’Urso	Ottoman	2163, 2163R		\$312.00	\$415.00
D’Urso	Ottoman, split upholstery	2163S, 2163RS		\$528.00	\$528.00
de Armas	de Armas Chair Collection	38A, 38AW, 38C, 28CW, 41A, 41AW, 41C, 41CW		\$58.00	\$58.00
de Armas	de Armas Chair Collection	38AW-U, 38CW-U, 41AW-U, 41CW-U		\$102.00	\$102.00

KnollStudio CAL 133 Approved Products (continued)					
Designer	Product	Pattern #	Unupholstered, no upcharge	Knoll Textiles, upcharge	Spinneybeck leather, upcharge
Jehs+Laub	Lounge Chair	JL1-P, JL1-PLt, JL2-P, JL2-PLT, JL1-W, JL1-WLT, JL2-W, JL2-WLT		\$239.00	\$324.00
Jehs+Laub	Ottoman Chair	JL3-P, JL3-PLT, JL3-W, JL3-WLT		\$91.00	\$160.00
Knoll	Lounge Chair	1205S1		\$556.00	\$655.00
Knoll	Settee	1205S2		\$969.00	\$1,145.00
Knoll	Sofa	1205S3		\$1,297.00	\$1,530.00
Knoll	Small Bench	2530Y2C		\$129.00	\$348.00
Knoll	Large Bench	2530Y3C		\$200.00	\$491.00
Kotilainen	CHIP Chair	23C, 23A	approved		
Lin	Stones, seat pad	83Y-K, 84Y-K		\$58.00	
Lissoni	Divina Petite Lounge Chair	67S		\$376.00	\$705.00
Lissoni	Divina Standard Lounge Chair	67, 67R		\$602.00	\$879.00
Lissoni	Divina Settee	68, 68R		\$925.00	\$1,391.00
Lissoni	Divina Optional Side Cushion	68C		\$83.00	
Lissoni	Divina Sofa	69, 69R		\$1,388.00	\$1,791.00
Lissoni	Divina Ottoman	73, 73R		\$330.00	\$602.00
Lovegrove	Sprite Arm and Armless Chair	27C, 27A	approved	\$58.00	\$58.00
Mies van der Rohe	Tubular Brno Chair	245AT, 245AB		\$611.00	\$611.00
Mies van der Rohe	Flat Bar Brno Chair	255AS, 255CS		\$611.00	\$611.00
Mies van der Rohe	Four Seasons Stool	257C			\$159.00
Mies van der Rohe	Barcelona Lounge Chair	250LS, 250LC			\$499.00
Mies van der Rohe	Child's Barcelona Chair	250LC-S			\$439.00
Mies van der Rohe	Barcelona Ottoman	251YS, 251YC			\$252.00
Mies van der Rohe	Child's Barcelona Ottoman	251YC-S			\$217.00
Mies van der Rohe	Krefeld Lounge Chair	751		\$532.00	\$845.00
Mies van der Rohe	Krefeld Settee	752		\$658.00	\$1,176.00
Mies van der Rohe	Krefeld Sofa	753		\$905.00	\$1,518.00
Mies van der Rohe	Krefeld Ottoman	754		\$247.00	\$441.00
Mies van der Rohe	Krefeld Medium Bench	755		\$412.00	\$691.00
Mies van der Rohe	Krefeld Large Bench	756		\$451.00	\$933.00
Pensi	Toledo Stacking Chair	29C	approved		
Pfister	Standard Lounge Chair, Petite Lounge Chair	1051C, 1051C-S		\$615.00	\$927.00
Pfister	Standard Settee	1052C		\$1051.00	\$1,605.00
Pfister	Standard Sofa	1053C		\$1,484.00	\$2,273.00
Pfister	Corner Module	1050C-3		\$574.00	\$942.00
Pfister	End Module, left panel and right panel	1050C-1, 1050C-2		\$515.00	\$804.00
Pfister	Center Module	1050C		\$421.00	\$664.00
Pfister	Standard Ottoman	1059C		\$323.00	\$445.00
Pollock	Executive/Conference Arm and Armless Chairs	12A, 12C		\$106.00	\$106.00
Ricchio	Joe Chair	48A		\$58.00	\$58.00
Ricchio	Ricchio Chair	37A, 37C		\$58.00	\$58.00
Ricchio	JR Chair	44A		\$58.00	\$58.00
Ricchio	Fully Upholstered Ricchio Chair	37A-U, 37C-U, 44A-U		\$161.00	\$161.00
Ricchio	Ricchio Barstool	37CH, 37CM		\$58.00	\$58.00
Risom	Risom Stool, Side and Lounge Chair	666C, 667Y, 666CS, 667YS, 654LA, 654LC		approved, no upcharge	approved, no upcharge
Saarinen	Executive Arm Chairs	71A		\$256.00	\$372.00
Saarinen	Executive Armless Chairs	72C		\$177.00	\$372.00
Saarinen	Womb Settee	73L		\$782.00	\$1,452.00
Saarinen	Womb Chair	70L		\$623.00	\$1,152.00
Saarinen	Medium Womb Chair	70LM		\$433.00	\$1,051.00
Saarinen	Womb Ottoman	74Y		\$188.00	\$344.00
Saarinen	Medium Womb Ottoman	74YM		\$147.00	\$301.00
Shelton Mindel	Side Chair	SM8A		\$58.00	\$58.00
Shelton Mindel	Side Chair Fully Upholstered	SM8A-U		\$161.00	\$159.00
Shelton Mindel	SM1 Lounge Chair	SM1-1		\$531.00	\$667.00

KnollStudio CAL 133 Approved Products (continued)					
Designer	Product	Pattern #	Unupholstered, no upcharge	Knoll Textiles, upcharge	Spinneybeck leather, upcharge
Shelton Mindel	SM1 Settee	SM1-2		\$740.00	\$951.00
Shelton Mindel	SM1 Sofa	SM1-3		\$927.00	\$1,261.00
Shelton Mindel	SM2 Lounge Chair	SM2-1		\$681.00	\$740.00
Shelton Mindel	SM2 Lounge Chair- combination	SM2S-1		\$1,199.00	\$1,199.00
Shelton Mindel	SM2 Settee	SM2-2		\$1,088.00	\$1,129.00
Shelton Mindel	SM2 Settee- combination	SM2S-2		\$1,777.00	\$1,777.00
Shelton Mindel	SM2 Sofa	SM2-3		\$1,599.00	\$1,741.00
Shelton Mindel	SM2 Sofa- combination	SM2S-3		\$2,521.00	\$2,521.00
Vignelli Associates	Handkerchief Arm and Armless Chair	4901K, 4902K	approved	\$58.00	

Each year Knoll sets key initiatives in our journey to sustainability. We are members of a global consortium on energy, have adopted a scientific, metrics-based approach to sustainable product design, and maintain a leadership position in establishing universal, verifiable, sustainability standards for our industry.

Knoll promotes independent third-party certification because it provides the most impartial and trustworthy foundation for industry-wide environmental compliance. Certification by established and respected third parties ensures that all manufacturers are held to the same high standards and that customers can trust a company's declaration about the environmental benefits of its products. Knoll third-party partners include: the International Standards Organization (ISO); Forest Stewardship Council (FSC®); Rainforest Alliance; GREENGUARD® Environmental Institute; and The Business and Institutional Furniture Manufacturer's Association (BIFMA) level® certification from Scientific Certification Systems (SCS).

In addition, Knoll is aligned with the U.S. Green Building Council and can help companies, healthcare organizations and educational institutions achieve Leadership in Energy and Environmental Design (LEED®) workplace certification.

Global Climate Change

- Knoll is a sponsor of the Clinton Global Initiative, which brings together a community of global leaders to devise and implement solutions to some of the world's most pressing challenges, including environmental change.
- Knoll has a comprehensive Energy Management Program to increase energy efficiency in products and processes.

Life Cycle Assessment (LCA) Tool

- Life Cycle Assessment is a science-based measurement of a product's environmental impacts throughout its life cycle, from raw materials sourcing through manufacture, shipping, use and re-use or end-of-life. LCA enables cradle-to-cradle implementation of sustainable practices.
- Knoll has partnered with The Green Standard.org to develop an affordable, universal ISO-compliant computer-based LCA tool that can be used by the entire contract furniture industry and is partnering on the development of an Environmental Product Declaration System (EPDs) for Knoll products. EPDs are verified documents containing LCA results and additional environmental performance information about a product.

Setting Industry Standards

- Knoll partners with MTS (The Institute for Market Transformation to Sustainability) to develop the SMaRT® Consensus Sustainable Products Standards, a set of consensus-based sustainable product standards based on the LEED® model, for all building products, fabric, apparel, flooring and carpet. MTS, the developer of SMaRT®, is an accredited American National Standards Institute (ANSI) standard developer.
- Knoll also partners with BIFMA (Business and Institutional Furniture Manufacturers Association) to promote level® sustainability standards for the contract furniture industry.
- Knoll has established FSC® (Forest Stewardship Council) certified wood as the standard for general office open plan office systems, casegoods and tables.
- Knoll has launched Full Circle, a resource recovery program developed with ANEW, to help customers extend the life cycle of surplus furniture, fixtures and equipment (FF&E) in an economically, socially and environmentally responsible manner.
- Our goal is to encourage all manufacturers in the contract furniture industry and related industries to adopt standards that will lead to sustainable products and practices.

For more information about Knoll and sustainable design, visit knoll.com/environment.

GREENGUARD™

- The most respected independent testing program for low-emitting products.
- GREENGUARD™ – certified products help reduce indoor air pollution and create healthier interior environments.
- Knoll GREENGUARD™ – certified products help achieve points for the U.S. Green Building Council’s LEED – CI (Commercial Interiors) Program.
- GREENGUARD™ – tested and certified office furniture is required for Credit 4.5 in the LEED – CI Indoor Environmental Quality section.

GREENGUARD™ provides the only guide to certified low-emitting interior products and building materials. Its goal is to help building owners and managers, architects, interior designers and product specifiers build and furnish healthier offices, hospitals, schools and homes by providing a register of tested and certified low-emitting products and materials. GREENGUARD™ certification is recognized by LEED. Air Quality Science, an Independent indoor air quality laboratory, tests products submitted for GREENGUARD™ certification using stringent environmental chamber testing protocols and current indoor air quality standards. Certification is administered by the GREENGUARD™ Environmental Institute.

Designer	Product
Side Chairs and Lounge Seating	
David Adjaye	Washington Skin and Skeleton Chairs
Paul Aferiat and Peter Stamberg	Salsa Lounge Seating
Edward Barber and Jay Osgerby	Piton Stools
Harry Bertoia	Side Chair, Barstools, Diamond Chairs, Bird Lounge Chair, Asymmetric Chaise
Cini Boeri	Lounge Collection
Marcel Breuer	Cesca Chair, Wassily Chair
Don Chadwick	Spark Series
Pepe Cortes	Jamica Barstool
Jonathan Crinion	Crinion Side Chair
Raul de Armas	de Armas Chair, Vertical de Armas Chair
Markus Jehs and Jürgen Laub	Jehs+Laub Lounge Collection
Antti Kotilainen	Chip Chair and Barstool
Florence Knoll	Lounge Seating
Marc Krusin	Wood Guest Seating Collection
Piero Lissoni	Divina Lounge Collection
Ross Lovegrove	Sprite Chair in Maple, Exotic Alpi and Veneer finishes
Maya Lin	Seats and Coffee Table
Vico Magistretti	Cirene Chair
Marco Maran	Gigi Chair, Gigi Swivel, Gigi Barstool, X3 Chair, X3 Barstool
Ludwig Mies van der Rohe	Brno Chairs, Four Seasons Stool, MR Chair, MR Lounge Chair, Barcelona Lounge Seating, Krefeld Lounge Seating
George Nakashima	Straight Chair
Jorge Pensi	Toledo Chair
Charles Pfister	Petite Lounge Seating, Lounge Seating, Sofa System
Warren Platner	Lounge Seating
Charles Pollock	Executive/ Conference Arm and Armless Chairs
Carlos Riart	Riart Rocker
Joe Ricchio	Joe Chair
Joe and Linda Ricchio	JR Chair, Ricchio Chair
Jens Risom	Side and Lounge Chairs
Eero Saarinen	Tulip Chairs, Executive Arm and Armless Chairs, Womb Chair and Ottoman
Richard Schultz	1966 Collection
Peter Shelton and Lee Mindel	Shelton Mindel Wood Side Chair
Kazhide Takahama	Suzanne Lounge Seating
Massimo and Lella Vignelli	Handkerchief Arm and Armless Chairs

Designer	Product
Tables	
David Adjaye	Washington Corona Table
Edward Barberand Jay Osgerby	Piton Side Table
Joseph D'Urso	D'Urso Tables with Laminate Top and PVC Edge; Granite Tops; Veneer Tops
Florence Knoll	Coffee and End Tables
Florence Knoll	Table Desks
Ross Lovegrove	Rectangular, Round and Tri-Oval Tables
Ludwig Mies van der Rohe	Barcelona Table, MR Table
Pascal Mourgue	Tables with laminate Tops and PVC Edge
George Nakashima	Splay-Leg Table
Isamu Noguchi	Cyclone Table
Jorge Pensi	Pensi Tables
Piironen	Arena Café Tables
Warren Platner	Platner Tables with Glass, Natural Marble and Veneer Tops
Jens Risom	Dining Table, Side Tables, Amoeba Coffee Table
Eero Saarinen	Saarinen Tables with Laminate, Natural Marble, Veneer or Granite Tops
Richard Schultz	1966 Collection
Peter Shelton and Lee Mindel	Shelton Mindel Side and Coffee Tables
Massimo and Lella Vignelli	PaperClip Café Tables

KnollStudio Finish Code Chart

Compatibility with Knoll Office Systems

Wood Compatibility Matrix

To match KnollStudio wood side chairs with Knoll Office or KnollStudio veneer finishes, please specify the appropriate Special code. Finishes are matched on either maple or beech basewood depending on depth of color.

Please note: this match is complimentary in color only. Perception can be affected by the variation in the grain of the basewood.

Example: **37A-BQV436-K784/74**

37A, Ricchio Side Chair

BQV436, V2 Natural Veneer - Medium Brown Cherry

K784/74, Knoll Velvet/Moss

To match Propeller, Pixel, and LSM with Knoll Office or KnollStudio finishes, please submit a request through CPD. Any of the finishes listed below may be used at no additional upcharge.

KNOLL OFFICE VENEER FINISHES			STUDIO WOOD SIDE CHAIR FINISHES	
	CUT	Standard Finish Code	Special Code - Maple	Special Code - Beech
V1 Engineered Techwoods				
Maple *	FC	Y316	•	•
Cherry *	FC	Y319	•	BQY319
Medium Walnut*	FC	Y323	•	B323
Dark Mahogany*	FC	Y326	•	BQY326
Light Oak*	RC	Y327	QY327	•
Medium Oak*	RC	Y329	•	BQY329
Wenge	QC	Y341	•	BQY341
Medium Teak	QC	Y342	•	BQY342
Dark Grey Oak	RC	Y343	•	BQY343
Espresso	QC	Y344	•	BQY344
Natural**	QC	Y811 (T)	QY811	•
Blond Maple (Maple)**	QC	Y821 (4)	KC	•
Light Cherry (Cherry)**	QC	Y831 (6)	•	BQY831
Medium Brown Mahogany	QC	C6F3 (7)	•	BQE7
Black Oak	RC	Y851	•	BQY851
Medium Red Mahogany	QC	C6F4 (8)	•	BQE8
* = previously Reff Techwoods, ** = previously, Morrison Techgrain. Names and codes in parenthesis () are names prior to 2009.				
V2 Natural Veneers				
Beech	FC	V311	•	B311
Bronzed Cherry	FC	V312	•	B312
Maple (Light Maple)	FC	V316	•	•
Mahogany on Beech	FC	V317	•	BQV317
Medium Cherry	FC	V319	•	BQV319
Medium Cherry on Beech	FC	V321	•	BQV321
Medium Walnut on Beech	FC	V322	•	BQV322
Light Walnut	FC	V411	•	BQV411
Peacock Green Walnut	FC	V415	•	BQV415
Old English Walnut	FC	V417	•	BQV417
Smoked Walnut	FC	V418	•	BQV418
Chalk Oak	RC	V421	QV421	•
Light Oak	RC	V423	QV423	•
Amber Oak	RC	V425	QV425	•
Brown Oak	RC	V427	•	BQV427
Light Fawn Cherry	FC	V433	•	BQV433
Medium Brown Cherry	FC	V436	•	BQV436
Straight Anigre	QC	V439	QV439	•
V3 Natural Exotic Veneers				
Figured Anigre	QC	V512	QV512	•
Graphite Oak	RC	V513	•	BQV513
Makore	QC	V514	•	BQV514
Figured Sycamore	QC	V515	•	•
Sapele	QC	V517	•	BQV517
Propeller Veneer Finishes				
American Cherry	FC	X	•	BQEX
Warm Brown Walnut	FC	J	•	BQEJ
Ebonized Walnut	FC	D	KE	BE

FC= Flat Cut Veneer, exhibits cathedral pattern

RC= Rift Cut Veneer, Straight Grain

QC = Quarter Cut Veneer, Straight Grain

• = Not possible

KnollStudio Natural Materials

Wood, marble, granite, and slate are natural materials that vary. Use material samples and printed sample materials as reference only.

KnollStudio printed and finish samples offer an example of what an “average” natural material may look like, within a range of acceptance carefully delineated by Knoll.

Because of the breadth of variations possible with any natural material, Knoll specialists select these materials with stringent criteria, accepting only the top 3 - 5% of what is available.

Wood*Knoll Natural Veneers*

All natural finishes are selected from the finest hardwoods available around the world. Veneers are flat cut and carefully matched so that cathedral or heart patterns are perfectly balanced. Natural veneers also are cut to allow a generous margin of quarter-grain figuring ensuring invisible splicing.

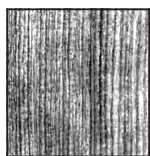

*Quarter
Pattern*

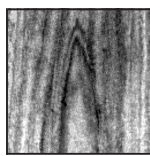

*Cathedral
Pattern*

Knoll Techgrain®

Knoll Techgrain is a veneer product that eliminates the inherent disparities in pattern, color and texture that characterize natural wood veneers. The consistency of Techgrain is important for uniformity. All KnollStudio Techgrains are non-figured and feature a regular, homogenous pattern.

The Techgrain process begins with wood veneers vat-dyed in natural vegetable mineral solines to create a perfectly clear, integrated color throughout. The veneer is finish coated with a clear water-white catalyzed varnish, a polymer finish which helps resist staining and marring. The result is a handsome surface with the appearance of a hand-rubbed oil finish.

Finishes

Most finishes are designed to coordinate with standard Morrison, Reff and Equity. For reference, consult the matrix on page 25.

Laminated Plywood (Cirene)

De Padova laminated plywood shells are made of the world's top 3-5% veneers available. The unique lamination process allows for an extremely thin yet sturdy shell with unmatched flexibility and dimensionality. Shells are finished in natural veneer or lacquer.

Marble, Granite and Slate

Knoll selects the highest quality, structurally sound marble, granite and slate available, through a host of quarries in Africa, South America, Greece, Turkey, Spain and Italy. Because each mountain range and quarry have their own signature, every marble piece - even within a single quarry - is unique. Hues, veins, crystals, fossils, clouds, and distinctive marks will vary from piece to piece. This is the extraordinary character of stone as a material. Below are the marbles, granites, travertines, and slates that KnollStudio offers:

Coated Marbles*Coated Marbles*

Coated marbles have transparent, high-polish, polyester coating to prevent use-associated stains. Even with this protection, coated marbles should not be used outdoors. Stains should be wiped immediately. Coating will yellow over time.

Satin Coated Marble

Satin coated marbles have transparent satin polyester coating to prevent use-associated stains. This satin finish gives the stone a natural, honed appearance while providing the same protective qualities as the Coated Marbles. Even with this protection, satin coated marbles should not be used outdoors. Stains should be wiped immediately. Coating will yellow over time.

Arabescato

Ivory white with dark grey veining. May contain random green veins.

Calacatta

Ivory white. Gold and beige random veins with additional veins varying from cream to green and grey.

Carrara

White background with grey veining.

Emperador Dark

Dark Brown with light brown and white veining. Natural finished stones will contain open fissures and pin-holes, which is considered a natural desirable trait.

Empire Beige

Yellowish-cream with yellow and rose colored veining and fissures.

Grey Marble

Grey with black and white veins. Hues vary in tone and intensity.

Nero Marquina

Rich black with random veins that can vary from white to gold.

Verde Alpi

Green. Black and white veins. Hues vary in tone and intensity.

Natural Marbles

Natural marbles have a protective sealer to protect the stone from aging and staining. Sealer has to be renewed periodically (see product maintenance on page 28). Natural marbles are not suitable for outdoor use.

Carrara

White background with grey veining.

Calacatta

Ivory white. Gold and beige random veins with additional veins varying from cream to green and grey.

Emperador Dark

Dark Brown with light brown and white veining. Natural finished stones will contain open fissures and pin-holes, which is considered a natural desirable trait.

Natural Granites

Natural granites have a sealer to protect the stone from aging and staining. Sealer has to be renewed periodically (see product maintenance on page 29). Because of its non-porous density, granite does not require protective polyester coatings.

Black Andes Granite

Black with reflective mica crystallines.

Slate

Natural cleft slate is available on Vignelli PaperClip Tables, SM Tables, and Saarinen Tables.

In combination with a weather-resistant base, PaperClip tables with slate tops are suitable for outdoor use. Please refer to respective product pages for recommended outdoor finish combinations.

Cane

A natural material, hand-woven for impeccable finish and smooth surface. Cane on Cesca chair has a light polyurethane coating for stain resistance.

Man-Made Materials & Finishes*Stainless Steel*

Completely rust-proof, highly durable, and resistant to bending stress. Light scratching blends with time.

Polished Chrome

Several-step plating process that includes a heavy layer of nickel for added rust protection and a bright mirror finish.

Satin Chrome

Chrome plating applied for a soft satinized chrome finish with a higher nickel content.

Nickel Finish

A warm, lustrous finish of nickel electroplate. Yellowish in color. Coated with clear lacquer to prevent oxidation.

Polished Aluminum

A shiny, polished finish.

Clear Anodized Aluminum

A light grey satin finish.

Fused Nylon Rilsan

A very durable and adhesive fused nylon-dipped finish. Scratch, chip, and chemical resistant. Appropriate for outdoor use.

Laminate/Color Core Laminate

An exceptionally durable plastic surface. Highly resistant to most chemicals and extensive wear.

Cotton Webbing

100% cotton unfinished webbing.

Cotton/Nylon Webbing

60% nylon, 40% cotton mixed yarns with silicone water-based protective coating.

Porcelain

An oven-baked finish on steel support with high durability.

Outdoor Powder Coat:

Durable outdoor powder finish that will provide excellent color and gloss retention with limited exposure to outdoor elements.

Painted, acid etched glass:

Clear glass with an acid etched top and painted underside. Polished and beveled edges surround.

Vetro Bianco:

Vetro Bianco is an engineered resin free quartz surface. The brilliant white surface is nonporous, stain proof, and extremely durable making it suitable for indoor and outdoor use.

With proper care, your KnollStudio furniture should last for years to come. To help ensure the longevity of your purchase, below are helpful hints on routine cleaning for your KnollStudio piece. Most basic maintenance can be performed with common household cleaning products.

Textiles

See KnollTextiles website for detailed cleaning and care instructions. Wipe all spills immediately. Brush and vacuum every three to four months. Use a foam upholstery cleaner as directed semi-annually, or more frequently if necessary. Try a hidden area to test for color fastness.

Spinneybeck Leathers

Leather is hardy and will adjust to its environment. It mellows gracefully with age. Leather is expected to change; even the oils from our hands help to develop the patina.

Full grain, aniline leather is undemanding. It breathes, has a life of its own, and requires little care. It should not be abused by harsh cleaners, or substances such as wax or mink oils which will clog the pores. A periodic wipe with a damp cloth is a sufficient means of cleaning under normal conditions.

Spinneybeck now offers a leather maintenance kit specifically designed for the 28 qualities offered. The kit includes a cleaner, conditioner and ink-remover and can be ordered by calling 1 800 482-7777. There are three types of kits:

- finished products
- full aniline products
- brush-sueded products

The following guidelines will help you to maintain the beauty of the leather without destroying any of its natural characteristics.

Naked Leather

(Capri, Cervo, Copenhagen, Cordovan, Distressed, Prima, Saddle)

Naked leathers contain no foreign substances that act as a barrier against spillage or staining. They should be selected with this in mind.

The only recommended cleaning method for naked leather is to wipe the entire surface with a soft woolen cloth and water. Do not spot rub for it will darken only that area. The idea is to even out any abrasions or stains.

With use, naked leather develops a beautiful patina that removes many small scratches and abrasions as body oils moisturize and revitalize the leather. Substantial body oil marks will also dissipate over time, particularly if rubbed down with cool water.

Protective Finished Leathers (Acqua, Alaska, Amazon, Andes, Antique, Arizona, Derby, Ducale, España, Forte, Hand Tipped, Portofino, Riva, Sabrina, Salon, Torello, Velluto Pelle, Vicenza, Volo)

For high traffic use, breathable protective finish allows leather not only to be practical but also easy to maintain. It can be cleaned by wiping the entire surface with a soft cloth and a very mild solution of Ivory Flakes and cold water, followed by wiping the entire surface with water alone.

Grain Sueded Leather (Ducale Velour, Marissa)

For maximum soil resistance and durability these leathers have received an impregnated soil resistant treatment in the drum which permeates the leather making it repellent to liquid and dirt.

Grain sueded leather can be maintained with moderate care because spillage will bead and roll off. However, spillage should not be allowed to puddle, and should be blotted dry immediately. For normal care, leather should be brushed occasionally, with a sueded cleaning block to help remove general soilage.

If you have further questions about the care and maintenance of Spinneybeck leather, call Spinneybeck Customer Service at 800 482-7777.

Cowhide Slings, Belting Leather

For normal cleaning, use a soft cloth dampened with a solution of mild soap or detergent (Ivory Flakes) well dissolved in water. Rub very lightly, never pressing hard. Do not use solvents because dye may run. For scratches, use liquid shoe polish and buff when dry. Any liquids spilled on leather should be mopped up as soon as possible in order to avoid being absorbed by the leather.

Natural Caning

Use water and glycerin every three months to keep cane from drying out.

Vinyl

Clean frequently with a mild detergent and water. Use leather or plastic cleaners for unusually heavy use. Do not use solvents such as gasoline because plastic surface will gum and deteriorate.

Wood

Clean with a commercial brand of liquid furniture polish twice a month. For stubborn dirt or light scratches, rub lightly with very fine steel wool before using furniture polish. To rejuvenate luster, apply a furniture cream as a last step. Do not use water or household solvents: they will destroy the protective finish.

Lacquer Finishes on Wood (Florence Knoll credenza)

Frequent cleaning recommended: once per week with heavy use or once per month with light use. Clean with ordinary household soaps or detergents, well dissolved in water. Polish with lemon oil using a very soft cloth. For stubborn dirt or light scratches, uniformly apply Cleanbright Liquid Ebony or Guardsman liquid furniture polish with cheesecloth. Allow ten minutes to dry and wipe with a clean, dry cloth. For nicks, chips, and deep scratches, contact a professional refinisher. Never use abrasives.

Teak

Do not apply teak oil if you are using your furniture outdoors. For teak furniture used indoors, wipe surface with soft cloth to remove dust. Apply thin layer of teak oil using a paint brush and wipe excess using a soft cloth. Oil can be applied every 3 months to maintain rich color.

Wood Frame Chairs

Clean with dry and soft cloth. Rub smoothly with damp, lukewarm cloth. Treat sturdy stains with household soap solution or a solution with dishwashing liquid. Wipe off with clean, dry cloth. Do not use acid or abrasive detergents.

Marble with Polyester Coating

Wash with lukewarm water. Wash more thoroughly with Windex, Fantastik, Ivory Flakes in warm water, or other non-abrasive solutions. Rinse with warm water and dry with a soft cloth.

Natural Marbles/Marbles without Polyester Coating

Cleaning: Wipe off stains and liquid spills immediately with water and soft cloth. Never use steel wool or other abrasives on marble.

Maintenance: The mineral surface of marble is very porous and easily absorbs moisture and fluids causing corrosion, staining and discoloring. If applied on a yearly basis, impregnators or penetrating sealers protect the interior of the stone, inhibit discoloration and allow the stone to breathe and release water vapor.

To restore a uniform luster, clean surface from any grit or debris, then remove all topical coatings with Stoneguard Stripper. Use Marbalex to rinse surface, then let top dry for twelve hours before applying stone impregnator. Apply SCI Impregnator using a clean and dry applicator brush. After five minutes, wipe off the excess with soft, white terry cloth. If impregnator is absorbed within five minutes apply second coat at least twelve hours later.

Never use steel wool or other abrasives on marble.

Slate

Apply a generous amount of soap solution (1:5) to the table top with a hard brush. Wipe off the top with a clean, damp cloth. Repeat as often as required. Apply mineral oil or lemon oil as needed to protect surface.

Granite

Clean with Windex, Fantastik, or other non-abrasive solutions on a regular basis. Apply a marble wax to improve luster and protect finish. Routine maintenance will prevent the stone from darkening with use from body oils, and will help maintain an evenness of color.

Vetro Bianco

Wash surface with lukewarm water. Clean more thoroughly with a non-abrasive solution such as Windex or Fantastik. Rinse with warm water and dry with a soft cloth. Wipe off stains immediately with water and a soft cloth. Never use steel wool or other abrasives on surface.

Glass/Acrylic Polycarbonate

Clean with Windex, Fantastik or other non-abrasive cleaning solutions. Wipe dry with a clean cloth.

Laminate/Melamine

Scrub with Windex, Fantastik, Mr. Clean, or other household soaps or detergents well dissolved in water, or with a very soft cloth dampened with alcohol or a synthetic thinner. For a dull finish, rub with jeweler's rouge as a polishing agent and finish with paste wax. Never use abrasives. Remove stubborn stains with Soft Scrub.

Stainless Steel

Use Windex, Fantastik, or other non-abrasive household cleaners. For small scratches, rub with Comet, Ajax, or other mild abrasives in the direction of the grain. Apply a coat of auto wax to maintain beauty.

Chrome/Satin Chrome

Clean with Windex or an automotive chrome cleaner such as Semi-Chrome twice a month. Apply a coat of hard paste wax to protect against moisture.

Nickel

Clean with Windex, Fantastik, or other non-abrasive cleaning solutions. If discoloration occurs, rub lightly with a fine steel wool to restore luster. Touch-up with a clear lacquer to prevent oxidation.

Copper

Polish using a soft cloth and metal polish cream such as BlueMagic®. Do not use harsh abrasive or steel wool.

Polished Aluminum

Clean with Windex, Fantastik, or other non-abrasive cleaning solutions. Coat with a hard paste wax semi-annually to maintain luster and prevent discoloration.

Anodized Aluminum

Clean with mild soaps, detergents, or other non-abrasive cleaning agents. Apply paste wax or DuPont non-abrasive car polish #7 twice a year to prevent oxidation.

For stubborn stains or discolorations, apply navel jelly aluminum cleaner.

Urethane Edge

Clean with household soaps and detergents well dissolved in water. Do not use abrasive cleaning solutions.

Epoxy

Clean with Windex, Fantastik, or other ordinary non-abrasive household soaps, detergents, or ammonia at least once a month to prevent yellowing. For scratches and chips, rub with Comet, Ajax, or other mild abrasives. For deeper scratches, contact Knoll for touch-up paint. Shine with a high grade auto polish. Never use harsh abrasives or steel wool.

Rilsan

Clean with Windex, Fantastik, or other ordinary non-abrasive household soaps or detergents. For ink stains on white surfaces, use Soft Scrub. For scratches and chips, rub with Comet, Ajax, or other mild abrasives. For deeper scratches, use a good grade automotive acrylic-lacquer touch-up paint. Shine with a high grade auto polish. Never use harsh abrasives or steel wool.

Porcelain

Clean with damp cloth using water or Windex. Do not use any abrasive detergent.

Powder Coat Paint

Clean with Windex or Endust using a soft cloth. Remove stubborn stains with Soft Scrub.

Polyester Shell

Clean with Windex or soap and water. Do not use any abrasive detergent.

Plastic Seat Shells

Clean with damp cloth with diluted soap. Wipe dry with clean cloth. Do not use any abrasive or acid detergents.

Cotton Webbing

Use damp cloth to clean. Do not use detergent or soap or any abrasive detergent.

Cotton/Nylon Webbing

Use damp cloth to wipe off stains.

Moving Parts

Lubricate moving parts every six months.

Swivel Mechanism

Apply a paste-type grease to swivel mechanism once a year.

Plastic/Polyethelene

Clean using a soft rag, either dry or wet. When needed, use mild pH-balanced soap diluted in water. Do not use abrasives sponges, acidic products or solvents containing ammonia.

To remove scuff marks, lightly rub scuff mark with a dry, non-scratch scour pad, like Scotch-Brite.

An assortment of our most popular products are available to ship in twenty working days:

Scope:

The KnollStudio 20-Day program offers a selection of products, finishes and upholstery materials for KnollStudio products only. 20-Day products and finishes are denoted by a helicopter () on the relevant page of the price list. See page 31 for a list of products and finishes, and maximum order quantities that are available within the 20-Day program.

Knoll will upholster 20-Day pieces in any approved KnollTextile or Spinneybeck leather that is in stock in sufficient quantity at time of order entry if not denoted otherwise. To check availability, call 1-800-523-0346 for KnollTextiles and 1-800-482-7777 for Spinneybeck leathers or contact your KnollStudio sales representative.

The upholstery scope listed below represents KnollTextiles and Spinneybeck leathers that are guaranteed to be in stock to support upholstered pieces on the 20-Day program unless noted otherwise in the upholstery column on page 31.

Availability:

20-Day orders can be fulfilled pending availability. Before specifying a 20-Day order, please check the lead time sheet on Knoll Exchange or contact your KnollStudio sales or customer resources representative to ensure availability.

Maximum order quantities are listed on page 31. Please check with your customer resources representative for availability of larger quantities.

For specific terms and conditions, consult the Knoll Group Selling Policy on pages 420-421.

Specification Guidelines:

20-Day orders should contain the following:

- Orders should be specified separately from standard lead time orders. Separate delivery charges may apply.
- A special prefix is required for 20-Day items. Please make sure all 20-Day items are marked with a “KS” prefix, as outlined on page 31.
- Full payment is required, including applicable tax and delivery fees.
- No changes or cancellations are allowed.
- 20-Day products are only available in the continental United States and Canada.

 KnollStudio 20-Day Program Upholstery Scope

Knoll will upholster 20-day pieces in any approved KnollTextile or Spinneybeck leather that is in stock at the time of order entry. To check availability, call 1-800-523-0346 for KnollTextiles or 1-800-482-7777 for Spinneybeck leathers, or contact your KnollStudio customer resources representative. The textile and leather selection listed below are reserved for the 20-day quickship program and are most likely to be instock at time of order entry.

KnollTextiles

Spinneybeck Leather

Grade A:	Grade B:	Grade C:	Grade G:	Grade U:
<p><i>Common Ground K448</i> 15 colorways, Teflon soil and stain repellent, 100% nylon content</p> <p><i>Mariner K642</i> 8 colorways, 100% nylon content</p>	<p><i>Vinyl K242</i> 10 colorways, outdoor approved, 100% vinyl face, backing 6% polyester, 91% vinyl, 3% cotton content</p>	<p><i>Classic Boucle K162</i> 13 colorways, 48% nylon, 52% wool content</p>	<p><i>Ultrasuede K1021</i> 21 colorways, high performance, stain resistant, 100% Polyester Ultra Microfiber content</p>	<p><i>Volo</i> Black (BLK) Toast(903)</p>

<i>Product</i>	<i>Code</i>	<i>Finish</i>	<i>Upholstery</i>	<i>Max. qty. per order</i>	<i>Page</i>
Side Chairs, Barstools and Lounge Seating					
Bertoia side chair	KS-420C-C	Chrome	unupholstered	10	46
Bertoia side chair	KS-420C-C-K	Chrome	In stock upholstery	10	46
Bertoia counter height stool	KS-427C-C	Chrome	unupholstered	5	52
Bertoia counter height stool	KS-427C-C-K	Chrome	In stock upholstery	5	52
Bertoia bar height stool	KS-428C-C	Chrome	unupholstered	5	50
Bertoia bar height stool	KS-428C-C-K	Chrome	In stock upholstery	5	50
Bertoia Diamond chair	KS-421L-C-K	Chrome	In stock upholstery	5	54
Bertoia Seat cushions	KS-420K, KS-427K, KS-428K		In stock upholstery	5	46
Wassily chair	KS-50L-BLBLCK KS-50L-BL1905	Black or Red Spinneybeck Belting Leather		2	90
Spark side chair	KS-4-C-SD-N	Red, Blue, Citron, Light Grey, Dark Grey, Recycled Black	unupholstered	25	92
Spark lounge chair	KS-4-C-LG-N	Red, Blue, Citron, Light Grey, Dark Grey, Recycled Black	unupholstered	25	92
Jamaica bar height stool	KS-30C-A	Aluminum top		10	96
Jamaica counter height stool	KS-30C2-A	Aluminum top		10	96
Chip armless chair	KS-23C	Chrome Base, White, Birch, Grey		10	138
Sprite armless chair	KS-27C	Chrome base, Black, White, Maple, solid front and back only		10	158
Gigi armless chair	KS-87C	White, Graphite, Black, Red, Navy		25	166
Gigi arm chair	KS-87A	White, Graphite, Black, Red, Navy		10	166
Gigi barstool, counter height	KS-87CM	White, Graphite, Black, Red, Navy		10	178
Gigi barstool, bar height	KS-87CH	White, Graphite, Black, Red, Navy		10	178
Barcelona chair	KS-250LC	Chrome	Volo Black (VO BLK)	2	192
Barcelona ottoman	KS-251YC	Chrome	Volo Black (VO BLK)	2	192
Toledo chair	KS-29C			10	204
Spoletto chair	KS-50CS-BLBLCK	Black belting leather		2	296
Womb chair	KS-70L-C	Chrome Base	Classic Boucle/Pearl Classic Boucle/Cayenne	2	252
Womb ottoman	KS-74Y-C	Chrome Base	Classic Boucle/Pearl Classic Boucle/Cayenne	2	252
Tables					
Albini desk	KS-80D-E	Ebonized		1	306
Laccio side table	KS-50T1	Black, white		2	310
Laccio coffee table	KS-50T2	Black, white		2	310
D'Urso square work table	KS-6348	In stock laminate, black legs, glides		10	312
D'Urso round work table	KS-6242	In stock laminate, black legs, glides		10	314
D'Urso racetrack work table	KS-6472	In stock laminate, black legs, glides		10	318
Florence Knoll tables	KS-2510T-C-G2 KS-2511T-C-G2	Chrome base, glass top		2	334
Pensi café table	KS-29TS-35-DE KS-29TR27-DE KS-29TR-39-DE	Disks		3	360
Arena round café table	KS-23TR36-C-W	Chrome base, white top		3	364
Barcelona table	KS-252C	Chrome base, clear glass top		1	346
MR table	KS-259TS-G			2	346
Cyclone dining table	KS-311-F2	White top		1	358
Platner side and coffee tables	KS-3710T-N-G2	Nickel base, clear glass top		2	366
	KS-3710T-BRM-G2 KS-3712T-BRM-G2 KS-3714-BRM-G2	Bronze base, clear glass top		2	366
	KS-3710T-BRM-BRG KS-3712T-BRM-BRG KS-3714T-BRM-BRG	Bronze base, bronze glass top		2	366

<i>Product</i>	<i>Code</i>	<i>Finish</i>	<i>Upholstery</i>	<i>Max. qty. per order</i>	<i>Page</i>
Tables, continued					
Saarinen dining tables	KS-173TR-F2-2 KS-176TR-F2-2 KS-164TR-F2-2	Laminate top, white base		2	374
Saarinen side and coffee tables	KS-169TR-LO-2 KS-169TR-F2-2 KS-163TR-F2-2	Light oak top, white base White laminate top, white base White laminate top, white base		1	380

Please see pages 30 and 33 for more information on placing a KnollStudio 20-Day order.

Use the Following Address:

If you would like to send an order directly to our order entry departments, please use the following address:

Knoll, Inc.
P.O. Box 157
East Greenville, PA 18041
Attn: Order Entry

Fax: 215 679-1570
Tel: 800 343-KNOLL

When Placing Your Order, Include:

- All information requested on the order form.
- Local taxes for the “delivered to” address.
- For orders \$2,000 or under (including applicable taxes and delivery/installation fees, if any), full payment must be made when order is placed.
- For orders over \$2,000, a deposit equal to one-half of the complete order value is required at order placement. Balance must be settled before shipment.
- For 20-day orders, please adhere to the specification guidelines on page 30.

Key Points to Remember:

All accepted orders will be confirmed in writing on the Knoll standard acknowledgement form. A copy of the acknowledgement will be mailed to the customer prior to production.

Freight within the 48 contiguous United States and Canada, excluding the Yukon, Northwest Territories and Newfoundland, is prepaid and included in the price of all orders.

For residential orders, Knoll strongly recommends White Glove delivery service to most locations in the Continental United States and Canada. White Glove service includes inside delivery, unpacking, furniture installation and removing cartons and crates. The fee for this service will be quoted at the point of purchase.

KnollStudio’s limited warranty covers all furniture against manufacturing defects in this price list for a period of five years after delivery to the customer.



All pricing is in U.S. dollars.

For More Information:

For complete Knoll Selling Policy and warranty information, please refer to pages 420-421 in the back of this price list.

For additional information on KnollStudio, contact your KnollStudio representative, a Knoll Space retailer or e-tailer, or telephone Customer Services at 800 343-KNOLL. To find the retailer or showroom nearest you, visit www.knoll.com.

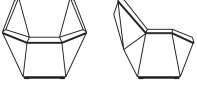
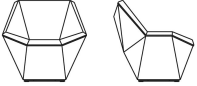
David Adjaye
The Washington Collection for Knoll™
Prism™ Lounge Chair and Ottoman

	description	w	d	h	height, seat	textile fabric yards
<p><i>Designer(s):</i> David Adjaye, 2014</p> <p><i>Award(s):</i> Editors Choice Award, Lounge Furniture Collection, NeoCon June 2015, USA; MetropolisLikes Award, Metropolis Magazine, June 2015, USA</p> 	<p>WL21F Lounge Chair, fixed base</p> 	33 3/4"	31 1/2"	31 1/2"	16 1/4"	2
	<p>WL21S Lounge Chair, swivel base</p> 	33 3/4"	31 1/2"	31 1/2"	16 1/4"	2
	<p>WL23 Ottoman</p> 	26 3/4"	17"	16 3/4"	15 1/2"	1

Order Code

<i>Example:</i>	WL21S-111G-K1882/9
WL21S	Lounge, swivel
111G	Black base
K1882/9	Melange/Onyx

Specify:

1. Pattern number
2. Base finish selection
3. Textile selection

Ordering Information

Base finishes:
 Black (suffix 111G)
 White (suffix 118G)
 Red (suffix 845G)

Maintenance:
 See pages 28-29.

Construction

Base:
 Constructed of 3/4" Baltic Birch plywood panels covered in a plastic color core laminate which maintains color throughout so vibrancy is maintained from edge to edge.
 Panels are assembled together using poplar wood corner blocks.

Upholstery:
 Textile upholstered over individual panels of urethane molded foam.

Note:
 Swivel base returns to center.

Approved Knoll Textiles Grades/Fab

A Hourglass Sonnet	C Circa Classic Boucle
B Bank Shot Cameo Chroma Journey Keaton Knoll Felt Knoll Hopsack Ransom Ricochet Synth	F Atelier Calais Cotton Velvet Cornaro Rivington

pattern no.	A	B	C	D	E	F	G	H	I
WL21F-(-)(\$14,095.	\$14,138.	\$14,186.	\$14,243.	\$14,322.	\$14,368.	\$14,449.	\$14,502.	\$14,662.
WL21S-(-)(14,522.	14,565.	14,613.	14,670.	14,749.	14,795.	14,876.	14,929.	15,089.
WL23-(-)(7,287.	7,308.	7,332.	7,361.	7,400.	7,423.	7,463.	7,490.	7,570.







G
Haze
Melange
Ultrasuede

H
Arno
Magritte
Rosemond

I
Ravello

*Check with your KnollTextiles
Representatives for changes or additions.*

David Adjaye
The Washington Collection for Knoll™
Skin™ and Skeleton™ Chair

	description	seat h	w	d	h	weight
<p><i>Designer(s):</i> David Adjaye, 2013</p> <p><i>Award(s):</i> 2014 Design Guild Mark Best of NeoCon Gold Award 2014</p>  	<p>WS2CN Washington Skin™ nylon chair</p> 	17 1/2"	18"	20 1/4"	32 1/2"	13 lbs.
	<p>WS1CA Washington Skeleton™ painted aluminum chair</p> 	17 1/2"	18"	20 1/4"	32 1/2"	20 lbs.
	<p>WS1CA Washington Skeleton™ nickel plated aluminum chair</p> 	17 1/2"	18"	20 1/4"	32 1/2"	20 lbs.
	<p>WS1CA Washington Skeleton™ copper plated aluminum chair, natural</p> 	17 1/2"	18"	20 1/4"	32 1/2"	20 lbs.
	<p>WS1CA Washington Skeleton™ copper plated aluminum chair with ceramic coating</p> 	17 1/2"	18"	20 1/4"	32 1/2"	20 lbs.

Order Code

<i>Example:</i>	WS1CA-001
WS1CA	Aluminum chair
001	Black paint finish

Specify:

1. Pattern number
2. Paint finish selection

Ordering Information

Nylon finishes:

- Black (suffix 011)
- White (suffix 012)
- Grey (suffix 013)
- Red (suffix 014)
- Orange (suffix 015)
- Yellow (suffix 016)
- Lime (suffix 017)

Aluminum paint finishes:

- Black (suffix 001)
- Grey (suffix 003)
- Green (suffix 007)
- White (suffix WHT)
- Sterling (suffix 906T)

Aluminum, plated finish:

- Copper, natural (suffix NCU)
- Copper, coated (suffix CC)
- Brushed Nickel (suffix NO)

Outdoor Use:

With proper maintenance painted aluminum chairs are appropriate for outdoor environments.

Maintenance:

See pages 28-29.

Construction

Nylon Chair:

Injection molded, glass reinforced nylon cantilevered chair. The chair's shell and legs are cast in three parts and are connected using mortise and tenon joinery and stainless steel fasteners. The unique leg design is reinforced internally with a cast aluminum brace. Features four integral glides that elevate and protect the leg profile.

Aluminum Chair:

Constructed from die-cast aluminum, the chair's shell and legs are cast in three parts and connected using mortise and tenon joinery and stainless steel fasteners. Available in ultra-durable powder coat paint, a nickel plated finish, a natural copper plated finish that will patina with age and a copper plated finish with ceramic coating that will maintain the original copper finish and prevent patina. Features four nylon glides.

Outdoor Use:

With proper care, the Washington Skeleton Chair in powder coat paint finishes is appropriate for outdoor environments.

Note:

Copper plated chairs without the ceramic coating will patina with age.

The Washington Skin and Washington Skeleton chairs are Greenguard certified.

pattern no.

WS2CN-()	\$637.
-----------------	--------

WS1CA-()	1,039.
-----------------	--------

WS1CA-NO	2,100.
-----------------	--------









WS1CA-NCU	2,100.
------------------	--------

WS1CA-CC	2,512.
-----------------	--------

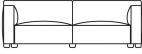
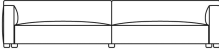
Edward Barber & Jay Osgerby

Sofa Collection

Lounge Seating

	description	seat h	arm h	w	d	h	textile fabric yds.	req. leather sq. ft.	
<p><i>Designer(s):</i> Edward Barber and Jay Osgerby, 2013</p>  	BO2 Two Seat Sofa	15 3/4"	25"	73 1/4"	40 1/4"	28 3/4"	10.7	220	
		BO3 Three Seat Sofa	15 3/4"	25"	85"	40 1/4"	28 3/4"	13	240
		BO4 Four Seat Sofa	15 3/4"	25"	132 1/4"	40 1/4"	28 3/4"	14.9	330
		BO5L Asymmetric Sofa, left	15 3/4"	25"	102 3/4"	40 1/4"	28 3/4"	12.3	270
		BO5R Asymmetric Sofa, right	15 3/4"	25"	102 3/4"	40 1/4"	28 3/4"	12.3	270
		BO15L Asymmetric Sofa with Chaise, left	15 3/4"	25"	102 3/4"	66"	28 3/4"	13.9	310
		BO15R Asymmetric Sofa with Chaise, right	15 3/4"	25"	102 3/4"	66"	28 3/4"	13.9	310
	BO6 Ottoman, small			29 1/2"	29 1/2"	15 1/4"	2.1	45	
	BO7 Ottoman, medium			35 1/2"	35 1/2"	15 1/4"	2.5	60	
									

Order Code

<i>Example:</i>	BO3-C-H800/19
BO3	Barber & Osgerby Three Seat sofa
C	Polished chrome
H800/19	Cato, Fire Red

Specify:

1. Pattern number
2. Base finish selection
3. Textile/leather selection

Ordering Information

Base/Leg Finish:
Chrome (suffix C)
Jet Black (suffix 111)
Medium Metallic Grey (suffix 612)
Red Coral (suffix CRL)

Upholstery/COM information:
Prices shown include fabric or leather upholstery. Contact your Knoll representative for colors. Only approved Knoll Textiles and Spinneybeck leathers may be ordered.

Customer's Own Material is available pending approval. For approval requirements, processing instructions and ordering information please see page 18.

Maintenance:
See pages 28-29.

Construction

Frame:
Hardwood and plywood construction with elastomeric suspension sheet webbing and foam supported sit-through feature at the cushion breaks.

Upholstery:
High density foam construction throughout with gel infused high density memory foam on top seating surface. All textiles must be railroaded - including COMs.

Asymmetric Sofa with Chaise:
The fabric on the sofa will always run perpendicular to the fabric on the chaise as both pieces must railroaded. Therefore, only textiles with a solid color and a non-specific directional weave may be used. Approved fabrics are noted with an asterisk (*).

Stitching:
Pinched topstitched seaming.

Legs:
Die cast aluminum legs with height adjustable glides.

Note:
Four Seat and Asymmetric Sofas come in two sections and are joined by a pin and socket locking mechanism in the joining leg.

All textiles must be railroaded - including COMs

pattern no.	grades A	COM B	C	D	E	F	G	H	I	COL U	V	W	X	Y
BO2-(-)(-)	\$7,710.	\$7,946.	\$8,211.	\$8,525.	\$8,960.	\$9,214.	\$9,657.	\$9,952.	\$10,834.	\$14,456.	\$15,403.	\$17,329.	\$17,730.	\$18,197.
BO3-(-)(-)	8,869.	9,157.	9,478.	9,860.	10,389.	10,697.	11,235.	11,594.	12,665.	16,181.	17,214.	19,316.	19,753.	20,263.
BO4-(-)(-)	11,634.	11,963.	12,332.	12,769.	13,376.	13,729.	14,346.	14,757.	15,985.	21,743.	23,164.	26,053.	26,654.	27,355.
BO5L-(-)(-)	10,064.	10,336.	10,640.	11,001.	11,502.	11,794.	12,303.	12,642.	13,656.	18,437.	19,600.	21,964.	22,456.	23,029.
BO5R-(-)(-)	10,064.	10,336.	10,640.	11,001.	11,502.	11,794.	12,303.	12,642.	13,656.	18,437.	19,600.	21,964.	22,456.	23,029.
BO15L-(-)(-)	11,819.	12,127.	12,471.	12,879.	13,445.	13,774.	14,350.	14,733.	15,878.	19,983.	21,318.	24,032.	24,597.	25,255.
BO15R-(-)(-)	11,819.	12,127.	12,471.	12,879.	13,445.	13,774.	14,350.	14,733.	15,878.	19,983.	21,318.	24,032.	24,597.	25,255.
BO6-(-)(-)	2,616.	2,663.	2,714.	2,776.	2,861.	2,912.	2,998.	3,056.	3,229.	4,043.	4,236.	4,630.	4,712.	4,808.
BO7-(-)(-)	2,921.	2,977.	3,039.	3,112.	3,214.	3,273.	3,376.	3,445.	3,651.	4,836.	5,029.	5,423.	5,505.	5,601.

Approved KnollTextiles Grades/Fabrics

A Delite Hourglass * Mariner * Presto * Sonnet	C Circa Classic Boucle * Lagos Spot On Star Struck Swing	D Compass CR Tara	G Haze Kingston * Melange * Sablon Ultrasuede *
B Bank Shot * Cameo Keaton Knoll Felt * Knoll Hopsack * Nonchalant Ricochet Spark Summit Westwood *		E Highland *	H Arno * Magritte *
		F Atelier Cornaro *	I Cato

Spinneybeck Leather

U Vicenza * Volo *	V Acqua * Andes * Embossed Tipped * España * Velluto Pelle *	Y Cordovan * Riva *
W Antique * Alaska * Forte * Lucente * Sabrina *		

*Approved for the Asymmetric Sofa with Chaise (BO15R, BO15L)

Check with your KnollTextiles or Spinneybeck Representative for changes or additions.

Edward Barber & Jay Osgerby
Sofa Collection
Compact Lounge Seating

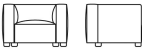
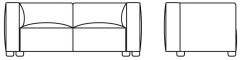
	description	seat h	arm h	w	d	h	textile fabric yds.	req. leather sq. ft.	weight
<i>Designer(s):</i> Edward Barber and Jay Osgerby, 2013 	BOC1 Armchair 	15 3/4"	25"	39 1/2"	33 3/4"	25"	5.9	125	
	BOC2 Two Seat sofa 	15 3/4"	25"	64 1/2"	33 3/4"	25"	8.7	175	

Order Code

<i>Example:</i>	BOC2-SGE-K1320/3
BOC2	Barber & Osgerby Two Seat sofa
SGE	Sage
K1320/3	Cornaro, Mist

Specify:

1. Pattern number
2. Base finish selection
3. Textile/leather selection

Ordering Information

Base/Leg Finish:
 Chrome (suffix C)
 Jet Black (suffix 111)
 Medium Metallic Grey (suffix 612)
 Red Coral (suffix CRL)

Upholstery/COM information:
 Prices shown include fabric or leather upholstery. Contact your Knoll representative for colors. Only approved Knoll Textiles and Spinneybeck leathers may be ordered.

Customer's Own Material is available pending approval. For approval requirements, processing instructions and ordering information please see page 18.

Maintenance:
 See pages 28-29.

Construction

Frame:
 Hardwood and plywood construction with elastomeric suspension sheet webbing and foam supported sit-through feature at the cushion breaks.

Upholstery:
 High density foam construction throughout with gel infused high density memory foam on top seating surface.

Stitching:
 Pinched topstitched seaming.

Legs:
 Die cast aluminum legs with height adjustable glides.

pattern no.	grades A	COM B	C	D	E	F	G	H	I	COL U	V	W	X	Y
BOC1-(-)(-)	\$4,762.	\$4,893.	\$5,039.	\$5,212.	\$5,452.	\$5,592.	\$5,836.	\$5,999.	\$6,485.	\$8,729.	\$9,268.	\$10,362.	\$10,590.	\$10,855.
BOC2-(-)(-)	6,703.	6,896.	7,111.	7,367.	7,720.	7,927.	8,287.	8,526.	9,243.	12,355.	13,108.	14,640.	14,960.	15,331.

Approved KnollTextiles Grades/Fabrics



A Delite Hourglass Mariner Presto Sonnet	C Circa Classic Boucle Lagos Spot On Star Struck Swing	D Compass CR Tara	G Kingston Haze Melange Sablon Ultrasuede
B Bank Shot Cameo Keaton Knoll Felt Knoll Hopsack Nonchalant Ricochet Spark Summit Westwood		F Atelier Cornaro	H Arno Magritte
		E Highland	I Cato

Spinneybeck Leather

U Vicenza Volo	Y Cordovan Riva
V Acqua Andes Embossed Tipped España Velluto Pelle	
W Antique Alaska Forte Lucente Sabrina	

Check with your KnollTextiles or Spinneybeck Representative for changes or additions.

Edward Barber & Jay Osgerby
Sofa Collection
Pillows

	description	w	d	textile fabric yds.	req. leather sq. ft.
<i>Designer(s):</i> Edward Barber and Jay Osgerby, 2013 	BO8P Pillow, small 	19"	19"	1.9	25
	BO9P Pillow, large 	23 1/2"	23 1/2"	2.6	30

Order Code

<i>Example:</i>	BO8P-K1054/9
BO8P	Small pillow
K1054/9	Circa/Red

Specify:

1. Pattern number
2. Textile selection

Ordering Information

Upholstery/COM information:
 Prices shown include fabric upholstery only. Contact your Knoll representative for colors. Only approved Knoll Textiles may be ordered.

Customer's Own Material is not approved.

Construction

Fill:
 Made from 90% feather and 10% down.

Ticking:
 100% cotton.

pattern no.	A	B	C	D	E	F	G	H	I	U	V	W	X	Y
BO8P-()	\$519.	\$561.	\$609.	\$664.	\$742.	\$787.	\$865.	\$918.	\$1,074.	\$1,210.	\$1,318.	\$1,537.	\$1,583.	\$1,636.
BO9P-()	694.	752.	816.	893.	998.	1,060.	1,168.	1,239.	1,453.	1,499.	1,627.	1,890.	1,945.	2,009.



Approved KnollTextiles Grades/Fabrics

A Delite Hourglass Mariner Presto Sonnet	C Circa Classic Boucle Lagos Spot On Star Struck Swing	D Compass CR Tara Woodland	G Haze Kingston Melange Sablon Striae Stripe Ultrasuede
B Bank Shot Cameo Keaton Knoll Felt Knoll Hopsack Nonchalant Ricochet Spark Summit Westwood		E Highland Kampala Meroe	H Arno Magritte
		F Atelier Cornaro Liberty	I Cato Digi Velvet Ita

Edward Barber & Jay Osgerby Piton™ Stools

Designer(s):
Edward Barber and Jay Osgerby,
2014



description	w	d	h	seat finish	weight
BO10C stool, indoor fixed height, swivel seat 	14 1/4"	14 1/4"	18"	Aluminum, polished	14 lbs.
	14 1/4"	14 1/4"	18"	Ash	12 lbs.
BO10CO stool, outdoor fixed height, swivel seat 	14 1/4"	14 1/4"	18"	Aluminum, painted (seat matches base)	14 lbs.
	14 1/4"	14 1/4"	18"	Teak	12 lbs.
BO11C stool, indoor adjustable height, swivel seat 	14 1/4"	14 1/4"	18" - 22"	Aluminum, painted (seat matches base)	15 lbs.
	14 1/4"	14 1/4"	18" - 22"	Aluminum, polished	15 lbs.
	14 1/4"	14 1/4"	18" - 22"	Ash	13 lbs.
	14 1/4"	14 1/4"	18" - 22"	Teak	13 lbs.

Order Code

<i>Example:</i>	BO10C-AP-CRLT
BO10C	Stool, indoor fixed height, swivel seat
AP	Aluminum, polished
CRLT	Red Coral

Specify:

1. Pattern number
2. Seat selection
3. Base selection

Ordering Information

Aluminum seat finishes:
Polished Aluminum (suffix AP)
Painted Aluminum Seat *:
Jet Black (Suffix 111T)
Med. Metallic Grey, (suffix 612T)
Red Coral (suffix CRLT)
Sterling (suffix 906T)
White (suffix WHTT)
(base must be specified in the same color)

Wood Seat Finishes:
Ebonized Ash (suffix AE)
Teak, natural (suffix K) *

*** Outdoor Use:**
The painted aluminum and teak seats are approved for outdoor use when used on the fixed height stool only

Base paint finishes:
Jet Black (suffix 111T)
Medium Metallic Grey (suffix 612T)
Red Coral (suffix CRLT)
Sterling (suffix 906T)
White (suffix WHTT)

Maintenance:
See pages 28-29.

Construction

Base:
Base is constructed of die-cast aluminum with stainless steel fasteners and finished with a highly durable powder coat paint.





Aluminum Seats:
Contoured die-cast aluminum seats are attached to the base with stainless steel fasteners. Available in a polished aluminum or painted with a highly durable powder coat paint.

Wood Seats:
Contoured wood seats are available in ebonized ash or an oiled teak.

pattern no.	list
BO10C-AP-()	\$675.
BO10C-AE-()	950.
BO10CO-()-()	575.
BO10CO-K-()	1,205.
BO11C-()-()	620.
BO11C-AP-()	720.
BO11C-AE-()	995.
BO11C-K-()	1,250.

Harry Bertoia

Side Chair

	description	seat h	w	d	h	textile fabric yds.	req. leather sq. ft.	weight
<i>Designer(s):</i> Harry Bertoia, 1952	420CU Side chair, full cover 	17 3/4"	21 3/4"	19 3/4"	28 3/4"	1.8	n/a	14 lbs.
		17 3/4"	21 3/4"	19 3/4"	28 3/4"	1.8	n/a	14 lbs.
<i>Award(s):</i> "Designer of the Year" 1955, USA; Certificate of Merit, American Institute of Architects	420F Full cover replacement					1.8	n/a	
	420C Side chair, back pad and seat cushion replacement 	17 3/4"	21 3/4"	19 3/4"	28 3/4"	1.5	n/a	14 lbs.
	420P Back pad replacement					0.7	n/a	
	420KP Back pad and seat cushion replacement					1.5	n/a	
	420C Side chair, seat cushion or unupholstered 	17 3/4"	21 3/4"	19 3/4"	28 3/4"	0.8	14	14 lbs.
		17 3/4"	21 3/4"	19 3/4"	28 3/4"	0.8	14	14 lbs.
420K Seat cushion replacement					0.8	14		

Order Code

<i>Example:</i>	420C-C-K-K242/13
420C	Side chair
C	Polished Chrome
K	Seat cushion
K242/13	Vinyl, White

Specify:

1. Pattern number
2. Finish selection
3. Upholstery option
4. Cal 133 Fire Code option
5. Textile selection

For cushion replacement specify:

1. Pattern number
2. Textile selection

Ordering Information

Frame finishes:
 Black (suffix BL)
 Blue (suffix BU)
 Green (suffix GE)
 Polished Chrome (suffix C)
 Red (suffix RD)
 Satin Chrome (suffix CO)
 White (suffix W)
 Yellow (suffix YL)

Upholstery options:
 Full cover (suffix U)
 Seat cushion only (suffix K)
 Back pad and seat cushion combination (suffix KP)

Upholstery/COM information:
 Prices shown include fabric or leather upholstery. Contact your Knoll representative for colors. Only approved KnollTextiles and Spinneybeck leathers may be ordered.

Customer's Own Material is available pending approval. For approval requirements, processing instructions and ordering information please see page 18.

 *KnollStudio 20 Day Program:*
 The Bertoia 420 Side Chair is available in polished chrome finish on the 20-day program unupholstered or with a seat cushion upholstered with in-stock KnollTextile. Replacement seat cushions are also available with in-stock KnollTextiles. For specific information, consult pages 30 - 33.



Outdoor use:
 With proper care and limited exposure to the elements, the Bertoia Collection is appropriate for outdoor environments. Specify powder coat finish (red, yellow, green, blue, black, white). Consult a Knoll representative for appropriate upholstery options.

Cal 133 Fire Code #:
 The Bertoia Chairs with seat cushion attached comply with the California Technical Bulletin 133 standard in all upholstery. **All textiles marked with a flame are also Cal 133 approved for full cover or seat and back pad upholstery.** Specify suffix -C at end of pattern number and suffix -133 at end of textile selection.

Note:
 The Knoll logo is stamped into the base of the chair.

The Bertoia Side Chair is Greenguard certified.

Maintenance:
 See pages 28-29.

pattern no.	unuph. (remove suffix -K)	grades	COM	A	B	C	D	E	F	G	H	I	COL	U	V	W	X	Y
420C-(-)U		\$1,554.	\$1,636.	\$1,710.	\$1,803.	\$1,870.	\$1,924.	\$2,006.	\$2,175.	\$2,297.								
420C-CO-U		1,814.	1,897.	1,971.	2,062.	2,131.	2,186.	2,267.	2,435.	2,557.								
420F-(-)		691.	766.	834.	916.	983.	1,028.	1,104.	1,260.	1,370.								
420C-(-)KP		1,668.	1,710.	1,751.	1,795.	1,832.	1,860.	1,903.	1,989.	2,124.								
420C-CO-KP		1,939.	1,981.	2,021.	2,066.	2,103.	2,130.	2,175.	2,260.	2,395.								
420P-(-)		461.	479.	496.	516.	530.	542.	561.	598.	626.								
420KP-(-)		734.	771.	808.	850.	883.	908.	949.	1,026.	1,084.								
420C-(-)K 	876.	1,099.	1,133.	1,170.	1,210.	1,242.	1,270.	1,307.	1,383.	1,442.	1,657.	1,792.	2,065.	2,121.	2,188.			
420C-CO-K	1,145.	1,370.	1,405.	1,440.	1,481.	1,513.	1,541.	1,577.	1,654.	1,711.	1,928.	2,062.	2,336.	2,392.	2,459.			
420K-(-) 	263.	294.	327.	363.	390.	413.	447.	515.	564.	756.	874.	1,112.	1,160.	1,214.				

Construction

Base and basket:
Welded steel with rods in polished or satin chrome, or highly durable outdoor power coat (red, yellow, green, blue, white, black). The diameter of the base rods are 11mm. The diameter of the edge rods is 4.5 mm and the interlacings measure 4mm. The chair features stainless steel connections and plastic glides.

Upholstery:
Cushion and back pad secured to chair with domed metal lock snaps. Seat cushions and back pads have fabric edges. Full covers are stretched over wire seat basket and attach to seat basket with hooks. Back pad is not available with leather upholstery.

Approved KnollTextiles Grades/Fabrics

A Bocce Common Ground * Commuter Cloth * Delite * Hourglass Mariner * Petal Pusher * Presto * Soliloquy Sonnet * Stacks Trophy *	B continued Roam Rush Hour Soiree Spree Starry Night Summit * Sutton Synth Tabloid Venue Versa Vinyl Wide Angle Zipline	C Axiom Biota Classic Boucle * Dahlia CR Durand Earthwork Entourage * Hula Hoop Lagos Milestone Moto CR Noble Quark Roundtrip Smart Spectator Spot On Swing * Tight Rope * Tower Grid * Transition * Vibe	D Hologram Masquerade Menagerie Theory Zoom	E Highland Ikat Stripe Ikat Square Kampala Katazome Kimono Luberon Marquee Sherman * Tryst	F Atelier * Calais Cotton Velvet Cornaro * Eclipse Glider Icon Liberty Mod Plaid Totem Tweed Frieze	G Arabella Haze * Kamani Kinabalu * Kingston Melange * Metallic Gloss Sablon * Serendipity Straie Stripe Ultrasede * Utrillo *	H Arno * Bavaria * Gezelle * Magritte * Rosemond	I Aswan Byron Cato * Cummings Dynamic Intrigue * Ita * Knoll Velvet * North Island * Ravello * Rutledge Tudor Vermeer * Zimba
---	--	--	---	---	---	---	--	--

Spinneybeck Leather





U Vicenza Volo	V Acqua Andes Embossed Tipped Hand Tipped Velluto Pelle	W Alaska Amazon Antique Arizona Derby Forte Lucente Sabrina	X Ducale Ducale Velour	Y Capri Cervo Copenhagen Cordovan Distressed Lucca Marissa Portofino Prima Riva Torello
-----------------------------	---	--	-------------------------------------	---

* Approved for fully upholstered versions.
▲ Approved for Cal 133 upholstery.

Check with your KnollTextiles or Spinneybeck Representative for changes or additions.

Harry Bertoia

Two-Tone Side Chair

	description	seat h	w	d	h	textile fabric yds	req. leather sq. ft	weight
<i>Designer(s):</i> Harry Bertoia, 1952	420CT-U Two-Tone Side chair, full cover 	17 3/4"	21 3/4"	19 3/4"	28 3/4"	1.8	n/a	14 lbs.
<i>Award(s):</i> "Designer of the Year" 1955, USA; Certificate of Merit, American Institute of Architects	420CT-KP Two-Tone Side chair, back pad and seat cushion 	17 3/4"	21 3/4"	19 3/4"	28 3/4"	1.5	n/a	14 lbs.
	420CT-K Two-Tone Side chair, seat cushion 	17 3/4"	21 3/4"	19 3/4"	28 3/4"	0.8	14	14 lbs.
	420F Full cover replacement					1.8	n/a	
	420KP Back pad and seat cushion replacement					1.5	n/a	
	420P Back pad replacement					0.7	n/a	
	420K Seat cushion replacement					0.8	14	

Order Code

Example: **420CT-U-BU-W-K242/13**

420CT-U	Two-Tone Side chair, fully upholstered
BU	Blue basket
W	White base
K242/13	Vinyl, White

Specify:

1. Pattern number
2. Basket finish selection
3. Base finish selection
4. Textile selection

For cushion replacement specify:

1. Pattern number
2. Textile selection

Ordering Information

Frame finishes:

- Polished Chrome (suffix C)
- Black (suffix BL)
- Blue (suffix BU)
- Red (suffix RD)
- White (suffix W)

Upholstery options:

- Full cover (suffix U)
-  Seat cushion only (suffix K)
- Back pad and seat cushion combination (suffix KP)

Upholstery/COM information:

Prices shown include fabric or leather upholstery. Contact your Knoll representative for colors. Only approved KnollTextiles and Spinneybeck leathers may be ordered.

Customer's Own Material is available pending approval. For approval requirements, processing instructions and ordering information please see page 18.

 **KnollStudio 20 Day Program:** Replacement seat cushions are available with in-stock KnollTextiles. For specific information, consult pages 30 - 33.

Cal 133 Fire Code #:

The Bertoia Chairs with seat cushion attached comply with the California Technical Bulletin 133 standard in all upholstery. **All textiles marked with a flame are also Cal 133 approved for full cover or seat and back pad upholstery.** Specify suffix -C at end of pattern number and suffix -133 at end of textile selection.

Note:

The Knoll logo is stamped into the base of the chair.

The Bertoia Side Chair is Greenguard certified.

Maintenance:

See pages 28-29.

pattern no.	unuph.	COM									COL				
		A	B	C	D	E	F	G	H	I	U	V	W	X	Y
420CT-U-(-)-(-)		\$1,554.	\$1,636.	\$1,710.	\$1,803.	\$1,870.	\$1,924.	\$2,006.	\$2,175.	\$2,297.					
420CT-KP-(-)-(-)		1,668.	1,710.	1,751.	1,795.	1,832.	1,860.	1,903.	1,989.	2,124.					
420CT-K-(-)-(-)	876.	1,099.	1,133.	1,170.	1,210.	1,242.	1,270.	1,307.	1,383.	1,442.	1,657.	1,792.	2,065.	2,121.	2,188.
420F-(-)		691.	766.	834.	916.	983.	1,028.	1,104.	1,260.	1,370.					
420KP-(-)		734.	771.	808.	850.	883.	908.	949.	1,026.	1,084.					
420P-(-)		461.	479.	496.	516.	530.	542.	561.	598.	626.					
420K-(-) 		263.	294.	327.	363.	390.	413.	447.	515.	564.	756.	874.	1,112.	1,160.	1,214.

Construction

Base and basket:
Welded steel with rods in polished chrome, or highly durable power coat (red, blue, white, black). The diameter of the base rods are 11mm. The diameter of the edge rods is 4.5 mm and the interlacements measure 4mm. The chair features stainless steel connections and plastic glides.

Upholstery:
Cushion and back pad secured to chair with domed metal lock snaps. Seat cushions and back pads have fabric edges. Full covers are stretched over wire seat basket and attach to seat basket with hooks. Back pad is not available with leather upholstery.

Note:
Two-Tone Bertoia Chairs are not appropriate for outdoor use.

Screws that attach the base to the basket are not painted to match the basket finish.

Approved KnollTextiles Grades/Fabrics

- A** Bocce
Common Ground *
Commuter Cloth *
Delite *
Hourglass
Mariner *
Petal Pusher *
Presto *
Soliloquy
Sonnet *
Stacks
Trophy *
- B** continued
Roam
Rush Hour
Soiree
Spree
Starry Night
Summit *
Sutton
Synth
Tabloid
Venue
Versa
Vinyl
Wide Angle
Zipline
- C** Axiom
Biota
Classic Boucle *
Dahlia CR
Durand
Earthwork
Entourage *
Hula Hoop
Lagos
Milestone
Moto CR
Noble
Quark
Roundtrip
Smart
Spectator
Spot On
Swing *
Tight Rope *
Tower Grid *
Transition *
Vibe
- D** Hologram
Masquerade
Menagerie
Theory
Zoom
- E** Highland
Ikat Stripe
Ikat Square
Kampala
Katazome
Kimono
Luberon
Marquee
Sherman *
Tryst
- F** Atelier *
Calais
Cotton Velvet
Cornaro *
Eclipse
Glider
Icon
Liberty
Mod Plaid
Totem
Tweed Frieze
- G** Arabella
Haze *
Kamani
Kinabalu *
Kingston
Melange *
Metallic Gloss
Sablon *
Serendipity
Straie Stripe
Ultr suede *
Utrillo *
- H** Arno *
Bavaria *
Gezelle *
Magritte *
Rosemond
- I** Aswan
Byron
Cato *
Cummings
Dynamic
Intrigue *
Ita *
Knoll Velvet *
North Island *
Ravello *
Rutledge
Tudor
Vermeer *
Zimba

Spinneybeck Leather

- U** Vicenza
Volo
- V** Acqua
Andes
Embossed Tipped
Hand Tipped
Velluto Pelle
- W** Alaska
Amazon
Antique
Arizona
Derby
Forte
Lucente
Sabrina
- X** Ducale
Ducale Velour
- Y** Capri
Cervo
Copenhagen
Cordovan
Distressed
Lucca
Marissa
Portofino
Prima
Riva
Torello





* Approved for fully upholstered versions.
▲ Approved for Cal 133 upholstery.

Check with your KnollTextiles or Spinneybeck Representative for changes or additions.

Harry Bertoia

Barstools

Bar Height Stools

	description	seat h	w	d	h	textile fabric yds.	req. leather sq. ft.	weight
<i>Designer(s):</i> Harry Bertoia, 1952	428CU Barstool, full cover, bar height 	29 1/4"	21 3/4"	22"	41 1/4"	1.8	n/a	22 lbs.
		29 1/4"	21 3/4"	22"	41 1/4"	1.8	n/a	22 lbs.
<i>Award(s):</i> "Designer of the Year" 1955, USA; Certificate of Merit, American Institute of Architects	428F Full cover replacement for 428C					1.8	n/a	
		428C-KP Barstool, back pad and seat cushion, bar height 	29 1/4"	21 3/4"	22"	41 1/4"	1.5	n/a
	428P Back pad replacement					0.7	n/a	
		428KP Back pad and seat cushion replacement					1.5	n/a
	428C Barstool, seat cushion or unupholstered, bar height 	29 1/4"	21 3/4"	22"	41 1/4"	0.8	14	21 lbs.
		29 1/4"	21 3/4"	22"	41 1/4"	0.8	14	21 lbs.
	428K Seat cushion replacement for 428C					0.8	14	

Order Code

Example: **428C-C-KP-K1021/8**

428C	Barstool, bar height
C	Polished Chrome
KP	Back and seat pad
K1021/8	Ultrasuede, Poppy

Specify:

1. Pattern number
2. Finish selection
3. Upholstery option
4. Cal 133 Fire Code option
5. Textile selection

For cushion replacement, specify:

1. Pattern number
2. Textile selection

Ordering Information

Frame finishes:

- Black (suffix BL)
-  Polished Chrome (suffix C)
- Satin Chrome (suffix CO)
- White (suffix W)

Upholstery options:

- Full cover (suffix U)
-  Seat cushion only (suffix K)
- Back pad and seat cushion combination (suffix KP)

Upholstery/COM information:

Prices shown include fabric or leather upholstery. Contact your Knoll representative for colors. Only approved KnollTextiles and Spinneybeck leather may be ordered.

Outdoor use:

With proper care and limited exposure to the elements, the 428 Bertoia Barstool is appropriate for outdoor environments. Specify outdoor powder coat. Consult a Knoll representative for appropriate upholstery options.

Customer's Own Material is available pending approval. For approval requirements, processing instructions and ordering information, please see page 18.

KnollStudio 20-Day Program:

The Bertoia 428 barstool is available in a polished chrome finish on the 20-Day Program unupholstered or with seat cushion upholstered with any in-stock KnollTextile. Seat cushion only is available on the 20-day program with any in-stock KnollTextile. For specific information, consult pages 30-33.

Cal 133 Fire Code ♣ :

The Bertoia Barstools with seat cushion attached comply with the California Technical Bulletin 133 standard in all upholstery. **All textiles marked with a flame are also Cal 133 approved for full cover or seat and back pad upholstery.** Specify suffix -C at end of pattern number and suffix -133 at end of textile selection.



Maintenance:

See pages 28-29.

Note:

The Knoll logo is stamped into the base of the barstool.

The Bertoia Bar Height stool is Greenguard certified.

pattern no.	unuph. (remove suffix -K)	grades A	COM B	C	D	E	F	G	H	I	COL U	V	W	X	Y
428C-(-)U		\$2,108.	\$2,179.	\$2,246.	\$2,322.	\$2,383.	\$2,430.	\$2,503.	\$2,644.	\$2,751.					
428C-CO-U		2,553.	2,624.	2,692.	2,767.	2,830.	2,875.	2,948.	3,091.	3,195.					
428F-(-)		691.	766.	834.	916.	983.	1,028.	1,104.	1,260.	1,370.					
428C-(-)KP		2,349.	2,392.	2,432.	2,476.	2,513.	2,540.	2,584.	2,669.	2,732.					
428C-CO-KP		2,814.	2,856.	2,896.	2,942.	2,978.	3,003.	3,049.	3,135.	3,195.					
428P-(-)		461.	479.	496.	516.	530.	542.	561.	598.	626.					
428KP-(-)		734.	771.	808.	850.	883.	908.	949.	1,026.	1,084.					
428C-(-)K 	1,555.	1,745.	1,778.	1,809.	1,845.	1,873.	1,894.	1,925.	1,995.	2,044.	2,232.	2,346.	2,582.	2,630.	2,686.
428C-CO-K	2,019.	2,209.	2,242.	2,272.	2,309.	2,338.	2,358.	2,391.	2,460.	2,508.	2,696.	2,810.	3,046.	3,096.	3,151.
428K-(-) 		263.	294.	327.	363.	390.	413.	447.	515.	564.	756.	874.	1,112.	1,160.	1,214.

Construction

Base and basket:
Welded steel with rods in polished or satin chrome or highly durable bonded powder coat (white and black). Stainless steel connections. Holes pre-drilled for easy snap-in installation. 1 1/4" wide round articulated glides on barstool. Black plastic glide with metal cover. Barstool base wire diameter measures 14mm, basket edge measures 7mm and interlacements measure 5 mm.

Upholstery:
Cushion and back pad secured to chair with domed metal lock snaps. Seat cushions and back pads have fabric edges. Full covers are stretched over wire seat basket and attach to seat basket with hooks. Back pad is not available with leather upholstery.

Approved KnollTextiles Grades/Fabrics

- A** Bocce
Common Ground *
Commuter Cloth *
Delite *
Hourglass
Mariner *
Presto *
Soliloquy
Sonnet *
Stacks
Trophy *
- B** Abacus
Bank Shot * 
Belize
Cameo
Digit
Ferry *
Forza
Grande
Grandview
Holbrook
Journey *
Keaton *
Knoll Felt * 
Knoll Hopsack * 
Night Life
Nonchalant CR
Petal Pusher *
Pop
Prairie
Prim 
Ransom *
Ricochet
Roam
Rush Hour
- B** continued
Soiree
Spree
Starry Night
Summit *
Synth
Venue
Versa
Vinyl
Wide Angle
Zipline
- C** Axiom
Biota
Classic Boucle * 
Dahlia CR
Durand
Earthwork
Entourage *
Hula Hoop
Lagos
Milestone
Moto CR
Noble
Quark
Roundtrip
Smart
Spectator
Spot On
Swing *
Tight Rope *
Tower Grid *
Transition *
Vibe
- D** Hologram
Masquerade
Menagerie
Origins
Theory
Zoom
- E** Highland
Ikat Stripe
Ikat Square
Kampala
Katazome
Kimono
Luberon
Marquee
Tryst
- F** Atelier *
Calais Cotton
Velvet
Cornaro *
Cuddle Cloth *
Eclipse
Glider
Groove Line
Icon
Intrigue *
Liberty
Mod Plaid
Totem
Tweed Frieze
- G** Arabella
Haze *
Kamani
Kinabalu *
Kingston
Melange *
Metallic Gloss
Straie Stripe
Sablon *
Serendipity
Ultrasuede *
- H** Arno * 
Bavaria *
Gezelle *
Magritte *
Rosemond
- I** Aswan
Byron
Cato *
Cummings
Dynamic
Ita *
Knoll Velvet *
North Island * 
Ravello *
Rutledge
Tudor
Vermeer *
Zimba

Spinneybeck Leather

- U** Vicenza
Volo
- V** Acqua
Andes
Embossed Tipped
Hand Tipped
Velluto Pelle
- W** Alaska
Amazon
Antique
Arizona
Derby
Forte
- W** continued
Lucente
Sabrina
- X** Ducale
Ducale Velour
- Y** Capri
Cervo
Copenhagen
Cordovan
Distressed
Lucca
Marissa
Portofino
Prima
Riva
Torello





* Approved for fully upholstered versions.
 Available for Cal 133 upholstery.

Check with your KnollTextiles or Spinneybeck Representative for changes or additions.

Harry Bertoia

Barstools

Counter Height Stools

	description	seat h	w	d	h	textile fabric yds.	req. leather sq. ft.	weight
<i>Designer(s):</i> Harry Bertoia, 1952	427CU Barstool, full cover, counter height 	27 1/2"	21 3/4"	22"	39 1/2"	1.8	n/a	20 lbs.
		27 1/2"	21 3/4"	22"	39 1/2"	1.8	n/a	20 lbs.
<i>Award(s):</i> "Designer of the Year" 1955, USA; Certificate of Merit, American Institute of Architects	427F Full cover replacement for 427C					1.8	n/a	
	427C-KP Barstool, back pad and seat cushion, counter height 	27 1/2"	21 3/4"	22"	39 1/2"	1.5	n/a	20 lbs.
	427P Back pad replacement					0.7	n/a	
	427KP Back pad and seat cushion replacement					1.5	n/a	
	427C Barstool, seat cushion or upholstered, counter height 	27 1/2"	21 3/4"	22"	39 1/2"	0.8	14	20 lbs.
		27 1/2"	21 3/4"	22"	39 1/2"	0.8	14	20 lbs.
	427K Seat cushion replacement for 427C					0.8	14	

Order Code

<i>Example:</i>	427C-C-U-K1207/2
427C	Barstool, counter height
C	Polished Chrome
U	Fully upholstered
K1207/2	Knoll Felt, Tan

Specify:

1. Pattern number
2. Finish selection
3. Upholstery option
4. Cal 133 Fire Code option
5. Textile selection

For cushion replacement, specify:

1. Pattern number
2. Textile selection

Ordering Information

Frame finishes:
Black (suffix BL)
 Polished Chrome (suffix C)
Satin Chrome (suffix CO)
White (suffix W)

Upholstery options:
Full cover (suffix U)
 Seat cushion only (suffix K)
Back pad and seat cushion combination (suffix KP)

Upholstery/COM information:
Prices shown include fabric or leather upholstery. Contact your Knoll representative for colors. Only approved KnollTextiles and Spinneybeck leathers may be ordered.

Outdoor use:
With proper care and limited exposure to the elements, the 427 Bertoia Barstool is appropriate for outdoor environments. Specify outdoor powder coat. Consult a Knoll representative for appropriate upholstery options.

Customer's Own Material is available pending approval for approval requirements, processing instructions and ordering information please see page 18.

 *KnollStudio 20-Day Program:*
The Bertoia 427 barstool is available in a polished chrome finish upholstered or with a seat pad on the 20-day program. Replacement seat cushion is also available. Seat cushion must be upholstered with an in-stock KnollTextile. For specific information, consult pages 30-33.



Cal 133 Fire Code ▲ :

The Bertoia Barstools with seat cushion attached comply with the California Technical Bulletin 133 standard in all upholstery. **All textiles marked with a flame are also Cal 133 approved for full cover or seat and back pad upholstery.** Specify suffix -C at end of pattern number and suffix -133 at end of textile selection.

Maintenance:
See pages 28-29.

Note:
The Knoll logo is stamped into the base of the barstool.

The Bertoia Counter Height stool is Greenguard certified

pattern no.	unuph. (remove suffix -K)	grades									COL					
		A	B	C	D	E	F	G	H	I	U	V	W	X	Y	
427C-(-)U		\$2,108.	\$2,179.	\$2,246.	\$2,322.	\$2,383.	\$2,430.	\$2,503.	\$2,644.	\$2,751.						
427C-CO-U		2,553.	2,624.	2,692.	2,767.	2,830.	2,875.	2,948.	3,091.	3,195.						
427F-(-)		691.	766.	834.	916.	983.	1,028.	1,104.	1,260.	1,370.						
427C-(-)KP		2,349.	2,392.	2,432.	2,476.	2,513.	2,540.	2,584.	2,669.	2,732.						
427C-CO-KP		2,814.	2,856.	2,896.	2,942.	2,978.	3,003.	3,049.	3,135.	3,195.						
427P-(-)		461.	479.	496.	516.	530.	542.	561.	598.	626.						
427KP-(-)		734.	771.	808.	850.	883.	908.	949.	1,026.	1,084.						
427C-(-)K 		1,555.	1,745.	1,778.	1,809.	1,845.	1,873.	1,894.	1,925.	1,995.	2,044.	2,232.	2,346.	2,582.	2,630.	2,686.
427C-CO-K		2,019.	2,209.	2,242.	2,272.	2,309.	2,338.	2,358.	2,391.	2,460.	2,508.	2,696.	2,810.	3,046.	3,096.	3,151.
427K-(-) 		263.	294.	327.	363.	390.	413.	447.	515.	564.	756.	874.	1,112.	1,160.	1,214.	

Construction

Base and basket:
Welded steel with rods in polished or satin chrome or highly durable bonded powder coat (white and black). Stainless steel connections. Holes pre-drilled for easy snap-in installation. 1 1/4" wide round articulated glides on barstool. Black plastic glide with metal cover. Barstool base wire diameter measures 14mm, basket edge measures 7mm and interlacements measure 5 mm.

Upholstery:
Cushion and back pad secured to chair with domed metal lock snaps. Seat cushions and back pads have fabric edges. Full covers are stretched over wire seat basket and attach to seat basket with hooks. Back pad is not available with leather upholstery.

Approved KnollTextiles Grades/Fabrics







- | | | | | | | | | |
|---|--|--|---|---|--|--|--|--|
| A
Bocce
Common Ground *
Commuter Cloth *
Delite *
Hourglass
Mariner *
Presto *
Soliloquy
Sonnet *
Stacks
Trophy * | B continued
Soiree
Spree
Starry Night
Summit *
Sutton
Synth
Venue
Versa
Vinyl
Wide Angle
Zipline | C
Axiom
Biota
Classic Boucle *
Dahlia CR
Durand
Earthwork
Entourage *
Hula Hoop
Lagos
Milestone
Moto CR
Noble
Quark
Roundtrip
Smart
Spectator
Spot On
Swing *
Tight Rope *
Tower Grid *
Transition *
Vibe | D
Hologram
Masquerade
Menagerie
Theory
Zoom | E
Highland
Ikat Stripe
Ikat Square
Kampala
Katazome
Kimono
Luberon
Marquee
Sherman *
Tryst | F
Atelier *
Calais Cotton
Velvet
Cornaro *
Cuddle Cloth *
Eclipse
Glider
Groove Line
Icon
Intrigue *
Liberty
Mod Plaid
Totem
Tweed Frieze | G
Arabella
Haze *
Kamani
Kinabalu *
Kingston
Melange *
Metallic Gloss
Sablon *
Serendipity
Straie Stripe
Ultrasuede *
Utrillo * | H
Arno *
Bavaria *
Gezelle *
Magritte *
Rosemond | I
Aswan
Byron
Cato *
Cummings
Dynamic
Ita *
Knoll Velvet *
North Island *
Ravello *
Rutledge
Tudor
Vermeer *
Zimba |
|---|--|--|---|---|--|--|--|--|

Spinneybeck Leather

- | | | | | | |
|-----------------------------|---|--|--|-------------------------------------|---|
| U
Vicenza
Volo | V
Acqua
Andes
Embossed Tipped
Hand Tipped
Velluto Pelle | W
Alaska
Amazon
Antique
Arizona
Derby
Forte | W continued
Lucente
Sabrina | X
Ducale
Ducale Velour | Y
Capri
Cervo
Copenhagen
Cordovan
Distressed
Lucca
Marissa
Portofino
Prima
Riva
Torello |
|-----------------------------|---|--|--|-------------------------------------|---|
- * Approved for fully upholstered versions.
‡ Available for Cal 133 upholstery.
- Check with your KnollTextiles or Spinneybeck Representative for changes or additions.*

Harry Bertoia

Diamond Lounge Seating

	description	seat h	w	d	h	textile fabric yds.	req. leather sq. ft.	weight
<i>Designer(s):</i> Harry Bertoia, 1952	421L Diamond chair, seat cushion with glides 	16 1/2"	33 1/2"	28 1/4"	30"	0.7	14	16 lbs.
		16 1/2"	33 1/2"	28 1/4"	30"	0.7	14	16 lbs.
		16 1/2"	33 1/2"	28 1/4"	30"	0.7	14	16 lbs.
<i>Award(s):</i> "Designer of the Year" 1955, USA; Certificate of Merit, American Institute of Architects	421K Seat cushion replacement					0.7	14	
	421LU Diamond chair, full cover with glides 	16 1/2"	33 1/2"	28 1/4"	30"	3.0	n/a	16 lbs.
		16 1/2"	33 1/2"	28 1/4"	30"	3.0	n/a	16 lbs.
	421F Full cover replacement					3.0	n/a	
	421LS Child's Diamond chair, seat cushion with glides 	11 3/4"	24 1/2"	22 3/4"	24"	0.7	11	9 lbs.
		11 3/4"	24 1/2"	22 3/4"	24"	0.7	11	9 lbs.
	421KS Child's Diamond, seat cushion replacement					0.7	11	
	421LS Child's Diamond chair, full cover with glides 	11 3/4"	24 1/2"	22 3/4"	24"	2.5	n/a	10 lbs.
		11 3/4"	24 1/2"	22 3/4"	24"	2.5	n/a	10 lbs.
	421FS Child's Diamond, full cover replacement					2.5	n/a	
	422LU Large diamond chair, full cover with glides 	15 1/4"	45"	31 1/2"	28 1/4"	3.8	n/a	24 lbs.
		15 1/4"	45"	31 1/2"	28 1/4"	3.8	n/a	24 lbs.
	422F Full cover replacement					3.8	n/a	

Order Code

<i>Example:</i>	421L-CO-U-K231/1
421L	Diamond chair
CO	Satin Chrome
U	Fully upholstered
K231/1	Cuddle Cloth, Neutral

Specify:

1. Pattern number
2. Finish selection
3. Upholstery option
4. Cal 133 Fire Code Option
5. Textile selection

For cushion replacement, specify:

1. Pattern number
2. Textile selection

Ordering Information

Frame finishes (421L,LU,LS):
 Black (suffix BL)
 Polished Chrome (suffix C)
 Satin Chrome (suffix CO)
 White (suffix W)
 18k Gold Plated (suffix GLD)

Frame finishes (422LU):
 Black (suffix 1)
 Polished Chrome (suffix C)
 White (suffix 2)

Upholstery options:
 Full cover (suffix U)
 Seat cushion only (suffix K)

Upholstery/COM information:
 Prices shown include fabric or leather upholstery. Contact your Knoll representative for colors. Only approved KnollTextiles and Spinneybeck leathers may be ordered.

Customer's Own Material is available pending approval. For approval requirements, processing instructions and ordering information please see page 18.

 *KnollStudio 20-Day Program:*
 The Diamond chair in a polished chrome finish is available on the KnollStudio 20-Day program with seat cushion upholstered with any in-stock KnollTextile. For specific information, consult pages 31 -33.

Outdoor use:
 With proper care and limited exposure to the elements, the 421 Bertoia Diamond Chair is appropriate for outdoor environments. Specify powder coat finish. Consult a Knoll representative for appropriate upholstery options.



Cal 133 Fire Code  :
 Bertoia 421 chair with seat pad attached complies with the California Technical Bulletin 133 standard in *all* upholstery. Cal 133 is approved for selected fabrics marked with a flame for fully upholstered versions. Specify suffix -C at end of pattern number.

Maintenance:
 See pages 28-29.

Note:
 The Knoll logo is stamped into the base of the chair.

The Bertoia Diamond Lounge Seating is Greenguard certified.

The Child's Diamond Chair is compliant to the Consumer Product Safety Improvement Act of 2008 for Children's Products, 16 C.F.R. 1303, CPSIA Title 1 Section 101 for Total Lead in Substrates and Surface Coatings.

pattern no.	grades									COL				
	A	B	C	D	E	F	G	H	I	U	V	W	X	Y
421L-(-)K 	\$1,728.	\$1,766.	\$1,804.	\$1,839.	\$1,870.	\$1,893.	\$1,932.	\$2,005.	\$2,056.	\$2,436.	\$2,580.	\$2,877.	\$2,940.	\$3,012.
421L-GLD-K 	2,990.	3,005.	3,022.	3,042.	3,069.	3,086.	3,114.	3,132.	3,188.	4,438.	4,497.	4,616.	4,640.	4,669.
421LCO-K	2,100.	2,138.	2,176.	2,211.	2,243.	2,266.	2,306.	2,377.	2,428.	2,809.	2,954.	3,251.	3,312.	3,385.
421K-(-)	437.	471.	502.	536.	564.	586.	617.	684.	733.	1,073.	1,207.	1,472.	1,526.	1,591.
421L-(-)U	2,728.	2,885.	3,025.	3,181.	3,308.	3,401.	3,557.	3,858.	4,078.					
421LCO-U	3,085.	3,242.	3,381.	3,537.	3,666.	3,757.	3,913.	4,215.	4,434.					
421F-(-)	1,067.	1,204.	1,329.	1,470.	1,583.	1,664.	1,808.	2,071.	2,268.					
421LS-C-K	1,009.	1,024.	1,038.	1,054.	1,067.	1,075.	1,095.	1,125.	1,153.	1,245.	1,307.	1,431.	1,457.	1,487.
421KS-(-)	259.	277.	296.	313.	330.	341.	361.	394.	422.	540.	611.	759.	790.	825.
421LS-C-U	1,311.	1,365.	1,417.	1,475.	1,522.	1,557.	1,616.	1,726.	1,806.					
421FS-(-)	658.	721.	785.	853.	908.	949.	1,017.	1,146.	1,241.					
422L-(C,1,2)U	3,644.	3,809.	3,956.	4,126.	4,259.	4,360.	4,529.	4,847.	5,081.					
422F-(-)	1,106.	1,247.	1,379.	1,524.	1,642.	1,728.	1,873.	2,151.	2,355.					

Construction



Frame:
Welded steel with rods in polished or satin (421L only) chrome finish, powder coat (white and black), or plated in 18k gold. Stainless steel connections. Four plastic glides. On all Diamond chairs, the base wire diameter measures 11mm. The frame edge wire diameter measures 4.5mm, the interlacements measure 4mm in diameter.

Upholstery:
Cushion secured to chair with lock-snaps. Full covers are stretched over wire frame and attach to seat basket with hooks. Cushions and covers fit all Bertioia Diamond Chairs manufactured since 1952 within a limited range of tolerance.

422L is not available with seat pad option.

Child's Diamond Chair:
The Child's Diamond Chair is 75% scale of the standard size and is only available with polished chrome frame.

Approved KnollTextiles Grades/Fabrics

- | | | | | | | | | | | | | | |
|---|--|---|---|---|--|---|--|--|--|---|--|---|--|
| A
Common Ground 
Delite
Hourglass
Mariner
Presto
Stacks *
Sonnet
Trophy | B continued
Prairie
Ransom *
Ricochet *
Starry Night *
Synth
Venue
Vinyl * | C
Classic Boucle 
Entourage
Hula Hoop *
Moto CR *
Quark *
Swing
Transition
Vibe * | D
Hologram *
Masquerade *
Satellite *
Zoom * | E
Highland
Luberon *
Marquee *
Sherman | F
Atelier
Calais Cotton
Velvet * | G
Cornaro
Eclipse *
Icon *
Intrigue
Totem *
Tweed Frieze * | H
Arno
Bavaria
Gezelle
Magritte | I
Cato
Dynamic
Ita
Knoll Velvet
North Island
Vermeer
Zimba | U
Haze
Kinabalu
Melange
Sablon
Ultrasuede 
Utrillo * | V
Acqua *
Andes *
Embossed Tipped *
Hand Tipped *
Velluto Pelle * | W
Alaska *
Amazon *
Antique *
Arizona *
Derby *
Forte *
Lucente *
Sabrina * | X
Ducale *
Ducale Velour * | Y
Capri *
Cervo *
Copenhagen *
Cordovan *
Distressed *
Lucca *
Marissa *
Portofino *
Prima *
Riva *
Saddle *
Salon *
Torello * |
|---|--|---|---|---|--|---|--|--|--|---|--|---|--|



Spinneybeck Leather

- * Available on 421K and 421KS seat cushion only.
 Available for Cal 133 upholstery.

Check with your KnollTextiles or Spinneybeck Representative for changes or additions.

Harry Bertoia

Two-Tone Diamond Chair

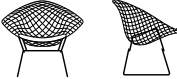
	description	seat h	w	d	h	textile fabric yds.	req. leather sq. ft.	weight
<p><i>Designer(s):</i> Harry Bertoia, 1952</p> <p><i>Award(s):</i> “Designer of the Year” 1955, USA; Certificate of Merit, American Institute of Architects</p> 	<p>421LT-U Two-Tone Diamond chair, full cover with glides</p> 	16 1/2"	33 1/2"	28 1/4"	30"	3.0	n/a	16 lbs.
	<p>421LT-K Two-Tone Diamond chair, seat cushion with glides</p> 	16 1/2"	33 1/2"	28 1/4"	30"	0.7	14	16 lbs.
	421F Full cover replacement					3.0	n/a	
	421K Seat cushion replacement					0.7	14	

Order Code

<i>Example:</i>	421LT-K-RD-BL-H800/19
421LT-K	Two-Tone Diamond chair, seat pad
RD	Red basket
BL	Black base
H800/19	Cato, Fire Red

Specify:

1. Pattern number
2. Basket finish selection
3. Base finish selection
4. Textile selection

For cushion replacement, specify:

1. Pattern number
2. Textile selection

Ordering Information

Frame finishes:

- Polished Chrome (suffix C)
- Black (suffix BL)
- Blue (suffix BU)
- Red (suffix RD)
- White (suffix W)

Upholstery options:

- Full cover (suffix U)
- Seat cushion only (suffix K)

Upholstery/COM information:

Prices shown include fabric or leather upholstery. Contact your Knoll representative for colors. Only approved KnollTextiles and Spinneybeck leathers may be ordered.

Customer's Own Material is available pending approval. For approval requirements, processing instructions and ordering information please see page 18.

Cal 133 Fire Code ✱ :

Bertoia 421 chair with seat pad attached complies with the California Technical Bulletin 133 standard in *all* upholstery. Cal 133 is approved for selected fabrics marked with a flame for fully upholstered versions. Specify suffix -C at end of pattern number.

Maintenance:

See pages 28-29.

Note:

The Knoll logo is stamped into the base of the chair.

The Bertoia Diamond Lounge Seating is Greenguard certified.

The Child's Diamond Chair is compliant to the Consumer Product Safety Improvement Act of 2008 for Children's Products, 16 C.F.R. 1303, CPSIA Title 1 Section 101 for Total Lead in Substrates and Surface Coatings.

pattern no.	grades		COM							COL				
	A	B	C	D	E	F	G	H	I	U	V	W	X	Y
421LT-U-(-)-(-)	\$2,728.	\$2,885.	\$3,025.	\$3,181.	\$3,308.	\$3,401.	\$3,557.	\$3,858.	\$4,078.					
421LT-K-(-)-(-)	1,728.	1,766.	1,804.	1,839.	1,870.	1,893.	1,932.	2,005.	2,056.	2,436.	2,580.	2,877.	2,940.	3,012.
421F-(-)	1,067.	1,204.	1,329.	1,470.	1,583.	1,664.	1,808.	2,071.	2,268.					
421K-(-)	437.	471.	502.	536.	564.	586.	617.	684.	733.	1,073.	1,207.	1,472.	1,526.	1,591.

Construction

Frame:
Welded steel with rods in polished chrome finish and powder coat. Stainless steel connections. Four plastic glides. On all Diamond chairs, the base wire diameter measures 11mm. The frame edge wire diameter measures 4.5mm, the interlacements measure 4mm in diameter.

Upholstery:
Cushion secured to chair with lock-snaps. Full covers are stretched over wire frame and attach to seat basket with hooks. Cushions and covers fit all Bertoia Diamond Chairs manufactured since 1952 within a limited range of tolerance.

Note:
Two-Tone Bertoia Diamond Chairs are not appropriate for outdoor use.

Screws that attach the base to the basket are not painted to match the basket finish.

Approved KnollTextiles Grades/Fabrics

- | | | | |
|--|---|---|--|
| <p>A
Common Ground ▲
Delite
Hourglass
Mariner
Presto
Stacks *
Sonnet
Trophy</p> | <p>B continued
Prairie
Ransom *
Ricochet *
Starry Night *
Synth
Venue
Vinyl *</p> <p>C
Classic Boucle ▲
Entourage
Hula Hoop *
Moto CR *
Quark *
Swing
Transition
Vibe *</p> | <p>D
Hologram *
Masquerade *
Satellite *
Zoom *</p> <p>E
Highland
Luberon *
Marquee *
Sherman</p> <p>F
Atelier
Calais Cotton
Velvet *
Cornaro
Dynamic
Eclipse *
Icon *
Intrigue
Totem *
Tweed Frieze *</p> | <p>G
Haze
Kinabalu
Melange
Sablon
Ultrasuede ▲
Utrillo *</p> <p>H
Arno
Bavaria
Gezelle
Magritte</p> <p>I
Cato
Dynamic
Ita
Knoll Velvet
North Island
Vermeer
Zimba</p> |
|--|---|---|--|

Spinneybeck Leather



- | | |
|--|---|
| <p>U
Vicenza *
Volo *</p> <p>V
Acqua *
Andes *
Embossed Tipped *
Hand Tipped *
Velluto Pelle *</p> <p>W
Alaska *
Amazon *
Antique *
Arizona *
Forte *
Lucente *
Sabrina *</p> | <p>X
Ducale *
Ducale Velour *</p> <p>Y
Capri *
Cervo *
Copenhagen *
Cordovan *
Distressed *
Lucca *
Marissa *
Portofino *
Prima *
Riva *
Saddle *
Salon *
Torello *</p> |
|--|---|

* Available on 421K seat cushion only.
▲ Available for Cal 133 upholstery.

Check with your KnollTextiles or Spinneybeck Representative for changes or additions.

Harry Bertoia

Bird Lounge Chair and Ottoman

	description	seat h	w	d	h	textile fabric yds.	req. leather sq. ft.	weight
<i>Designer(s):</i> Harry Bertoia, 1952	423LU Bird high back chair, full cover with glides	14 1/2"	38 1/2"	33"	40 1/4"	3.8	n/a	21 lbs.
<i>Award(s):</i> "Designer of the Year," USA, 1955; Certificate of Merit, American Institute of Architects; Design Center Stuttgart Award, W. Germany, 1962								
	423F Full cover replacement					3.8	n/a	
	424YU Ottoman, full cover with glides	14 1/2"	23 1/2"	17 1/4"	14 1/2"	1.3	n/a	9 lbs.
								
	424F Full cover replacement					1.3	n/a	



Order Code

<i>Example:</i>	423L-C-U-K1084/9
423L	Bird high back chair
C	Polished Chrome
U	Full cover
K1084/9	Harrison, Dunbar

Specify:

1. Pattern number
2. Finish selection
3. Upholstery option
4. Textile selection

For cushion replacement, specify:

1. Pattern number
2. Textile selection

Ordering Information

Frame finishes:

Black (suffix 1)
Polished Chrome (suffix C)
White (suffix 2)

Upholstery/COM information:

Prices shown include fabric or leather upholstery. Contact your Knoll representative for colors. Only approved KnollTextiles and Spinneybeck leathers may be ordered.

Customer's Own Material is available pending approval. For approval requirements, processing instructions and ordering information please see page 18.

Cal 133 Fire Code ▲:

The Bird chair and ottoman complies with the California Technical Bulletin 133 standard if upholstered in Cal133 approved KnollTextiles. Specify suffix -C at end of pattern number and suffix -133 at end of textile selection.

Maintenance:

See pages 28-29.

Note:

The Knoll logo is stamped into the base of the chair and bench.

The Bertoia Bird Lounge Seating is Greenguard certified.

Construction

Frame:

Welded steel with rods in polished chrome or bonded rilsan, a very durable and adhesive fused nylon-dipped finish. Scratch, chip, and chemical resistant. Stainless steel connections. Four plastic glides. Frame wire diameter measures 4.5mm. Interlacement wire diameter measures 4mm.

Upholstery:

High back chairs only available with full cover. Full covers are stretched over wire frame and attach to seat basket with hooks. Full cover replacement for High Back Chairs fit all Bertoia High Back Chairs manufactured since 1952 within a limited range of tolerance.

pattern no.	grades A	COM B	C	D	E	F	G	H	I
423L-(C,1,2)-U	\$4,360.	\$4,533.	\$4,696.	\$4,877.	\$5,021.	\$5,127.	\$5,307.	\$5,652.	\$5,902.
423F-()	1,350.	1,507.	1,657.	1,820.	1,952.	2,050.	2,209.	2,528.	2,753.
424Y-(C,1,2)-U	1,421.	1,478.	1,529.	1,593.	1,643.	1,682.	1,737.	1,858.	1,943.
424F-()	569.	622.	670.	722.	771.	805.	857.	967.	1,045.



Approved KnollTextiles Grades/Fabrics

A Common Ground Delite Hourglass Mariner Presto Sonnet Trophy	C Classic Boucle ‡ Entourage Ferry Swing Transition	H Arno Bavaria Gezelle Magritte
B Bank Shot ‡ Journey Keaton Knoll Felt Knoll Hopsack Synth	E Highland	I Cato Dynamic Ita Knoll Velvet North Island Vermeer Zimba
	F Atelier Cornaro Intrigue	
	G Haze Melange Sablon Ultrasuede	

*Check with your KnollTextiles
Representative for changes or additions.*

Harry Bertoia

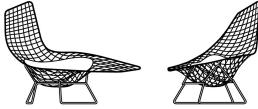
Asymmetric Chaise

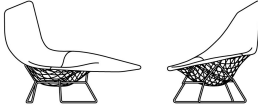
	description	seat h	w	d	h	textile fabric yds.	weight
Designer(s): Harry Bertoia, 1952 Award(s): Honorable Mention, Annual Design Awards, ID Magazine 2006	429L Asymmetric Chaise, unupholstered, with glides 		52"	38½"	40¼"		23 lbs.
	429L Asymmetric Chaise, seat pad, with glides 		52"	38½"	40¼"	2.5	24 lbs.
	429K Seat cushion replacement					2.5	
	429L Asymmetric Chaise, fully upholstered, with glides 		52"	38½"	40¼"	4.5	22 lbs.
	429F Full cover replacement					4.5	

Order Code

<i>Example:</i>	429L-C-U-K1152/8
429L	Asymmetric chaise
C	Polished Chrome
U	Fully upholstered
K1152/8	Stirling, Cobble

Specify:

1. Pattern number
2. Frame finish
3. Upholstery option
4. Textile selection

For seat cushion replacement specify:

1. Pattern number
2. Textile selection

Ordering Information

Frame finishes:
 Chrome (suffix C)
 White (suffix 2)

Upholstery options:
 Fully upholstered (suffix U)
 Seat cushion only (suffix K)

Upholstery/COM information:
 Prices shown include fabric or leather upholstery. Contact your Knoll representative for colors. Only approved KnollTextiles and Spinneybeck leathers may be ordered.

Customer's Own Material is available pending approval. For approval requirements, processing instructions and ordering information please see page 18.

Outdoor Use:

With proper care and limited exposure to the elements, the 429 Bertoia Asymmetric chaise is appropriate for outdoor environments. Specify rilsan finish. Consult a Knoll representative for appropriate upholstery options.

Cal 133 Fire Code ▲:

The Asymmetric chaise complies with the California Technical Bulletin 133 standard if upholstered in Cal 133 approved KnollTextiles. Specify suffix -C at end of pattern number and suffix -133 at end of textile selection.

Maintenance:

See pages 28-29.

Note:

The Knoll logo is stamped into the base of the Chaise.

The Bertoia Asymmetric Chaise is Greenguard certified.

Construction

Frame:

Welded steel rods in polished chrome or bonded white rilsan, a very durable and adhesive fused nylon-dipped finish. Scratch, chip and chemical resistant. Chrome chair features chrome connections. White rilsan chair features stainless steel connections suitable for outdoor use. Holes are drilled for the glides, and are included with the Chaise.

Upholstery:

Seat cushion secured to chair with lock-snaps. Full covers are stretched over wire frame and attach with hooks. Seat cushions and full covers will ship already attached to the chaise. If ordering a full cover replacement, installation must be performed by Knoll Field Services.

pattern no.	grades A	COM B	C	D	E	F	G	H	I
429L- ()	\$10,039.								
429L- ()-K	10,780.	10,853.	10,926.	11,006.	11,071.	11,121.	11,200.	11,355.	11,466.
429K- ()	788.	859.	929.	1,004.	1,066.	1,109.	1,187.	1,330.	1,437.
429L- ()-U	11,502.	11,638.	11,771.	11,915.	12,031.	12,119.	12,264.	12,539.	12,740.
429F- ()	1,878.	2,007.	2,130.	2,267.	2,379.	2,460.	2,596.	2,856.	3,045.

Approved KnollTextiles Grades/Fabrics

A Delite Hourglass Mariner Presto * Sonnet Trophy	C Classic Boucle † Entourage Ferry Swing * Transition * E Highland	F Atelier Cornaro Intrigue G Haze * Kinabalu * Melange Sablon Ultrasuede *	H Arno ** Bavaria Gezelle Haiku Magritte I Fiori Ita Knoll Velvet * North Island Vermeer Zimba Dynamic *
--	---	---	---

* Available on seat cushion only.
** Available on full cover only.

*Check with your KnollTextiles
Representative for changes or additions.*

Harry Bertoia Bench

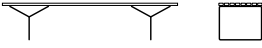
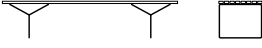
	description	seat h	w	d	h	textile fabric yds.	req. leather sq. ft.	weight	frame
<i>Designer(s):</i> Harry Bertoia, 1952 	400Y Bench 	15 1/4"	72"	19"	15 1/4"			32 lbs.	Chrome
	400K Seat cushion (one of maximum three)		19"	19"	3"	1.2	15	2 lbs.	
	410Y Outdoor Teak Bench 	15 1/4"	72"	19"	15 1/4"			32 lbs.	Paint
		15 1/4"	72"	19"	15 1/4"			32 lbs.	Stainless
	410K Outdoor Seat cushion (one of maximum three)		19"	19"	3"	1.2	15	2 lbs.	

Order Code

<i>Example:</i>	400Y-CBL
400Y	Bench
C1	Chrome frame with black slats
<i>Example:</i>	400K-H800/19
400K	Seat cushion
H800/19	Cato, Fire Red
<i>Example:</i>	410K-K1557/8
410K	Outdoor Seat Cushion
K1557/8	Baxter, Hazel

Specify:

1. Pattern number
2. Frame/Slat finish selection
3. Seat cushion option
4. Textile selection

For seat cushion only, specify:

1. Pattern number
2. Textile selection

Ordering Information

Bench frame/slat finish combinations:

Chrome/black (suffix CBL)
Chrome/white (suffix CW)
Black/teak (suffix BLK)
White/teak (suffix WK)
Stainless/teak (suffix SK)

Upholstery/COM information:

Prices shown include fabric or leather upholstery. Contact your Knoll representative for colors. Only approved Knoll Textiles and Spinneybeck leathers may be ordered.

Customer's Own Material is available pending approval. For approval requirements, processing instructions and ordering information please see page 18.

Maintenance:

See pages 28-29.

Note:

The Knoll logo is stamped into the base of the bench.

Construction

Bench platform:

Solid wood horizontal slats pre-treated to help prevent sagging or warping. Slats in black or white painted finish and teak. Base wire diameter measures 12mm.

Platform bench cushion available separately: firm foam cushions upholstered with welt detail. Three cushions maximum per bench.

Outdoor use:

With proper care and preventative maintenance, benches specified with painted or stainless steel base and teak slats are appropriate for outdoor use.

To specify outdoor bench cushions, use pattern number 410K and appropriate outdoor upholstery.

Outdoor paint:

Ultra-durable polyester powder coat paint.

pattern no.	grades	COM	A	B	C	D	E	F	G	H	I	COL	U	V	W	X	Y
400Y-(CBL,CW)	\$3,451.																
400K(-)		453.	500.	543.	592.	632.	662.	709.	802.	872.	958.	1,074.	1,308.	1,359.	1,413.		
410Y-(BLK, WK)	2,549.																
410Y-SK	3,219.																
410K(-)		0.	500.	543.	0.	0.	0.	0.	0.	0.	0.	0.	0.	0.	0.	0.	0.

Approved KnollTextiles Grades/Fabrics

A	Alignment Bocce Cat's Cradle Chance Common Ground Commuter Cloth Dristi Foil Rap Heavy Metal Hourglass Mariner Monarch Prep Presto Soliloquy Sonnet Stacks Trophy	B	continued Ludlow Lyric Mini Stitch Night Life Nonchalant CR Paradigm Petal Pusher Pogo Pop Prairie * Prim Radiance Ransom Ricochet Roam Rush Hour Soiree Spark Spinoff Nuance Spree Starry Night Summit Sutton Synth Venue Versa Westwood Wide Angle Zephyr Zipline	C	continued Enmesh Entourage Fable CR Fibra Greenwich Hudson Hula Hoop Kaleidoscope CR Kora CR Lagos Legend CR Lore CR Metro Milestone Moto CR Noble * Palisade Panache CR Quark Regard CR Roundtrip Sahara Sandpiper Sequin CR Sinclair * Smart Spectator Spot On Star Struck Stepping Stones Swing Tilden Tower Grid Transition Treble CR Vibe Zari CR	D	Compass CR Coterie Eclat Weave Hologram In The Loop Island Masquerade Menagerie Origins Satellite Satin Chisel Tara Theory Woodland Zoom Ikat Stripe Ikat Square Kampala Katazome Kimono Luberon Mamba Marquee Meroe Sherman Shima Tryst	E	Atelier Biscayne Century Coco Cornaro Eclipse Glider Icon Intrigue Liberty Mod Plaid Rivington Topography Totem Tweed Frieze
----------	--	----------	---	----------	---	----------	--	----------	--

Spinneybeck Leather

U	Vicenza Volo	V	Acqua Andes Embossed Tipped España Hand Tipped Maremma Velluto Pelle	W	Alaska Amazon Antique Arizona Derby Forte Lucente Sabrina	X	Ducale Ducale Velour	Y	Capri Cervo Copenhagen Cordovan Distressed Lucca Marissa Portofino Prima Riva Saddle Salon Torello
----------	-----------------	----------	--	----------	--	----------	-------------------------	----------	--

*Appropriate for outdoor use. Specify 410K.

Check with your KnollTextiles or Spinneybeck Representative for changes or additions.

Pierre Beucler and Jean-Christophe Poggioli
 Architecture & Associés
 Contract Lounge Seating

Designer(s):
 Pierre Beucler and
 Jean-Christophe Poggioli, 2012



description	seat h	arm h	w	d	h	type	textile fabric yds	leather sq ft	weight
AAC4 AA Small Lounge chair, low back, std. wing, same upholstery, frame and cushions	16 1/2"	—	27 3/8"	32 3/4"	30 1/8"		4.4	81	—
AAC4 AA Small Lounge chair, low back, std. wing, combination upholstery, frame and cushions	—	—	—	—	—	frame uph.	2.4	41	—
	—	—	—	—	—	upchg, cushions	2.3	40	—
AAC1 AA Lounge chair, low back, std. wing, arm cushions, same upholstery, frame and cushions	16 1/2"	—	31 1/2"	32 3/4"	30 1/8"		6.3	113	—
AAC1 AA Lounge chair, low back, std. wing, arm cushions, combination upholstery, frame and cushions	—	—	—	—	—	frame uph.	3.2	50	—
	—	—	—	—	—	upchg, cushions	3.5	63	—

Order Code

Example: **AAC4-CU-K1479/6-K1406/7**

AAC4	AA Small Lounge Chair
CU	Copper legs
K1479/6	Surround in Haiku, Storm
K1406/7	Cushions in Sonnet, Denim

Specify:

1. Pattern number
2. Leg finish
3. Textile selection

Specify with split upholstery:

1. Pattern number
2. Leg finish
3. Textile selection, Surround
4. Textile selection, Cushions

Ordering Information

Leg finishes:
 Chrome (suffix C)
 Copper (suffix CU)

Copper leg upcharge:
 Copper leg finish is available at an upcharge of \$382 list. Use suffix CU to specify.

Upholstery/ COM information:
 Prices shown includes fabric or leather upholstery. Contact your Knoll representative for colors. Only approved KnollTextiles and Spinneybeck leathers may be ordered.

Customer's Own Material is available pending approval. For approval requirements, processing instructions and ordering information please see page 18.

Maintenance:
 See pages 28-29.

Construction

Frame:
 Constructed in two formed plywood frames, back and seat, giving the pieces their architectural form. Frames are softened with highly resilient urethane foam wrapping.

Upholstery:
 Interior loose cushions are available in either residential or contract versions. Contract cushions provide a tailored look for high use areas, while residential cushions convey a relaxed aesthetic. For units with combination upholstery, add list price of surround in appropriate grade with the list price of cushions to obtain total list price for item.

Cushion fill:
 "Contract" back and seat cushion are multi-density urethane foam.

Legs:
 Machined steel legs feature height adjustable feet for leveling.

pattern no.	grades A	COM B	C	D	E	F	G	H	I	COL U	V	W	X	Y
AAC4-(-)(-)	\$3,878.	\$3,975.	\$4,069.	\$4,172.	\$4,255.	\$4,317.	\$4,419.	\$4,615.	\$4,761.	\$5,821.	\$6,180.	\$6,910.	\$7,063.	\$7,240.
AAC4S-(-)(-)(-)	2,936.	2,989.	3,040.	3,096.	3,142.	3,175.	3,230.	3,337.	3,418.	3,865.	4,046.	4,417.	4,494.	4,584.
AAC4 cushions	1,148.	1,201.	1,249.	1,303.	1,347.	1,379.	1,433.	1,535.	1,611.	2,034.	2,211.	2,572.	2,647.	2,734.
AAC1-(-)(-)	4,259.	4,399.	4,533.	4,680.	4,801.	4,887.	5,035.	5,315.	5,522.	6,886.	7,386.	8,406.	8,618.	8,864.
AAC1S-(-)(-)(-)	3,164.	3,237.	3,304.	3,379.	3,440.	3,484.	3,560.	3,702.	3,807.	4,269.	4,491.	4,942.	5,035.	5,144.
AAC1 cushions	1,308.	1,386.	1,461.	1,543.	1,610.	1,657.	1,739.	1,895.	2,011.	2,694.	2,974.	3,542.	3,661.	3,798.

Approved KnollTextiles Grades/Fabrics

A Chance Common Ground Commuter Cloth Delite Dristi Hourglass Mariner Prep * Presto * Sonnet Stacks * Trophy	B Argyle * Bank Shot Belize * Cameo Chroma Ferry * Journey Knoll Felt ■ Knoll Hopsack Ludlow Lyric	C Atlas * Biota * Charm *† Circa * Classic Boucle Decade * Earthwork Enmesh * Entourage Hudson Hula Hoop Kora CR * Lagos	D Eclat Weave * Menagerie Satellite *	E Highland Kampala * Katazome Sherman Shima	F Atelier Calais Cotton Velvet * Coco * Cornaro Icon Liberty Rivington * Soon Topography *	G Hampshire * Haze Kamani * Kingston Melange Ultrasuede	H Arno Gezelle Magritte Rosemond	I Cato Dynamic Knoll Velvet *† Ravello *† Rutledge Tudor Vermeer
---	--	--	---	---	---	--	---	--

Spinneybeck Leather

U Vicenza Volo	V Acqua Andes Embossed Tipped España Velluto Pelle	W Alaska Amazon Antique Arizona Forte Sabrina	X Ducale Velour	Y Capri Cervo Copenhagen Cordovan Distressed Marissa Prima Riva Saddle
-----------------------------	--	--	---------------------------	--

* Not approved on frame
† Indicates fabrics without topstitching
■ Knoll Felt/Ivory K1207/I not approved

Check with your KnollTextiles or Spinneybeck Representative for additions or changes.

Pierre Beucler and Jean-Christophe Poggioli
 Architecture & Associés
 Contract Lounge Seating

Designer(s):
 Pierre Beucler and
 Jean-Christophe Poggioli, 2012



description	seat h	arm h	w	d	h	type	textile fabric yds	leather sq ft	weight
AAC2 AA Settee, low back, std. wing, arm cushions, same upholstery, frame and cushions	16 1/2"	—	58"	32 3/4"	30 1/8"		9.3	170	—
AAC2 AA Settee, low back, std. wing, arm cushions, combination upholstery, frame and cushions	—	—	—	—	—	frame uph.	4	70	—
	—	—	—	—	—	upchg, cushions	5.3	100	—
AAC3 AA Sofa, low back, std. wing, arm cushions, same upholstery, frame and cushions	16 1/2"	—	85 1/4"	32 3/4"	30 1/8"		11.5	225	—
AAC3 AA Sofa, low back, std. wing, arm cushions, combination upholstery, frame and cushions	—	—	—	—	—	frame uph.	4.7	90	—
	—	—	—	—	—	upchg, cushions	7.2	138	—

Order Code

Example: **AAC4-CU-K1479/6-K1406/7**

AAC4	AA Small Lounge Chair
CU	Copper legs
K1479/6	Surround in Haiku, Storm
K1406/7	Cushions in Sonnet, Denim

Specify:

1. Pattern number
2. Leg finish
3. Textile selection

Specify with split upholstery:

1. Pattern number
2. Leg finish
3. Textile selection, Surround
4. Textile selection, Cushions

Ordering Information

Leg finishes:
 Chrome (suffix C)
 Copper (suffix CU)

Copper leg upcharge:
 Copper leg finish is available at an upcharge of \$382 list. Use suffix CU to specify.

Upholstery/ COM information:
 Prices shown includes fabric or leather upholstery. Contact your Knoll representative for colors. Only approved KnollTextiles and Spinneybeck leathers may be ordered.

Customer's Own Material is available pending approval. For approval requirements, processing instructions and ordering information please see page 18.

Maintenance:
 See pages 28-29.

Construction

Frame:
 Constructed in two formed plywood frames, back and seat, giving the pieces their architectural form. Frames are softened with highly resilient urethane foam wrapping.

Upholstery:
 Interior loose cushions are available in either residential or contract versions. Contract cushions provide a tailored look for high use areas, while residential cushions convey a relaxed aesthetic. For units with combination upholstery, add list price of surround in appropriate grade with the list price of cushions to obtain total list price for item.

Cushion fill:
 "Contract" back and seat cushion are multi-density urethane foam.

Legs:
 Machined steel legs feature height adjustable feet for leveling.

pattern no.	grades A	COM B	C	D	E	F	G	H	I	COL U	V	W	X	Y
AAC2-(-)(-)	\$6,012.	\$6,219.	\$6,416.	\$6,634.	\$6,811.	\$6,939.	\$7,156.	\$7,571.	\$7,877.	\$10,001.	\$10,754.	\$12,287.	\$12,606.	\$12,978.
AAC2S-(-)(-)(-)	4,416.	4,504.	4,590.	4,682.	4,760.	4,814.	4,908.	5,086.	5,218.	5,982.	6,292.	6,924.	7,056.	7,208.
AAC2 cushions	1,906.	2,023.	2,135.	2,260.	2,361.	2,434.	2,557.	2,793.	2,968.	4,112.	4,556.	6,518.	5,645.	5,864.
AAC3-(-)(-)	7,683.	7,938.	8,182.	8,451.	8,671.	8,830.	9,098.	9,611.	9,988.	13,006.	14,004.	16,032.	16,455.	16,947.
AAC3S-(-)(-)(-)	5,554.	5,659.	5,759.	5,868.	5,958.	6,022.	6,132.	6,341.	6,496.	7,588.	7,987.	8,798.	8,968.	9,164.
AAC3 cushions	2,553.	2,715.	2,868.	3,035.	3,173.	3,272.	3,440.	3,761.	3,997.	5,599.	6,212.	7,456.	7,715.	8,018.

Approved KnollTextiles Grades/Fabrics

A Chance Common Ground Commuter Cloth Delite Dristi Hourglass Mariner Prep * Presto * Sonnet Stacks * Trophy	B Argyle * Bank Shot Belize * Cameo Chroma Ferry * Journey Knoll Felt ■ Knoll Hopsack Ludlow Lyric	C Atlas * Biota * Charm *† Circa * Classic Boucle Decade * Earthwork Enmesh * Entourage Hudson Hula Hoop Kora CR * Lagos	D Eclat Weave * Menagerie Satellite *	E Highland Kampala * Katazome Sherman Shima	F Atelier Calais Cotton Velvet * Coco * Cornaro Icon Liberty Rivington * Soon Topography *	G Hampshire * Haze Kamani * Kingston Melange Ultrasuede	H Arno Gezelle Magritte Rosemond	I Cato Dynamic Knoll Velvet *† Ravello *† Rutledge Tudor Vermeer
---	--	--	---	---	---	--	---	--

Spinneybeck Leather

U Vicenza Volo	V Acqua Andes Embossed Tipped España Velluto Pelle	W Alaska Amazon Antique Arizona Forte Sabrina	X Ducale Velour	Y Capri Cervo Copenhagen Cordovan Distressed Marissa Prima Riva Saddle
-----------------------------	--	--	---------------------------	--



* Not approved on frame
† Indicates fabrics without topstitching
■ Knoll Felt/Ivory K1207/I not approved

Check with your KnollTextiles or Spinneybeck Representative for additions or changes.

Pierre Beucler and Jean-Christophe Poggioli
 Architecture & Associés
 Contract Lounge Seating

Designer(s):
 Pierre Beucler and
 Jean-Christophe Poggioli, 2012



description	seat h	arm h	w	d	h	type	textile fabric yds	leather sq ft	weight
AAC5 AA Small Ottoman, same upholstery, frame and cushions 	–	–	27 1/2"	24 1/2"	16"		2.2	40	–
AAC5 AA Small Ottoman, combination upholstery, frame and cushions	–	–	–	–	–	frame uph.	1.2	18	–
	–	–	–	–	–	upchg, cushions	1.3	22	–
AAC6 AA Medium Ottoman, same upholstery, frame and cushions 	–	–	31 1/8"	29 1/2"	16"		3.3	60	–
AAC6 AA Medium Ottoman, combination upholstery, frame and cushions	–	–	–	–	–	frame uph.	1.8	28	–
	–	–	–	–	–	upchg, cushions	2.3	32	–
AAC7 AA Large Ottoman, same upholstery, frame and cushions 	–	–	59"	29 1/2"	16 1/2"		4.5	70	–
AAC7 AA Large Ottoman, combination upholstery, frame and cushions	–	–	–	–	–	frame uph.	2.2	31	–
	–	–	–	–	–	upchg, cushions	2.7	43	–

Order Code

<i>Example:</i>	AAC7-C-K1617/3
AAC7	AA Large Ottoman
C	Chrome legs
K1617/3	Dynamic, Radiant

Specify:

1. Pattern number
2. Leg finish
3. Textile selection

Specify with split upholstery:

1. Pattern number
2. Leg finish
3. Textile selection, Surround
4. Textile selection, Cushions

Ordering Information

Leg finishes:
 Chrome (suffix C)
 Copper (suffix CU)
Copper leg upcharge:
 Copper leg finish is available at an upcharge of \$382 list. Use suffix CU to specify.

Upholstery/ COM information:
 Prices shown includes fabric or leather upholstery. Contact your Knoll representative for colors. Only approved KnollTextiles and Spinneybeck leathers may be ordered.

Customer's Own Material is available pending approval. For approval requirements, processing instructions and ordering information please see page 18.

Maintenance:
 See pages 28-29.

Construction

Frame:
 Constructed in two formed plywood frames, back and seat, giving the pieces their architectural form. Frames are softened with highly resilient urethane foam wrapping.

Upholstery:
 Interior loose cushions are available in either residential or contract versions. Contract cushions provide a tailored look for high use areas, while residential cushions convey a relaxed aesthetic. For units with combination upholstery, add list price of surround in appropriate grade with the list price of cushions to obtain total list price for item.

Cushion fill:
 "Contract" back and seat cushion are multi-density urethane foam.

Legs:
 Machined steel legs feature height adjustable feet for leveling.

pattern no.	grades A	COM B	C	D	E	F	G	H	I	COL U	V	W	X	Y
AAC5-()-()	\$2,272.	\$2,323.	\$2,369.	\$2,419.	\$2,463.	\$2,492.	\$2,544.	\$2,642.	\$2,714.	\$3,259.	\$3,436.	\$3,797.	\$3,873.	\$3,959.
AAC5S-()-()-()	1,728.	1,755.	1,780.	1,809.	1,831.	1,848.	1,876.	1,930.	2,075.	2,129.	2,209.	2,372.	2,405.	2,445.
AAC5 cushions	685.	715.	743.	773.	798.	816.	846.	904.	947.	1,168.	1,266.	1,464.	1,506.	1,554.
AAC6-()-()	2,394.	2,467.	2,537.	2,614.	2,677.	2,722.	2,800.	2,946.	3,055.	3,812.	4,078.	4,620.	4,732.	4,864.
AAC6S-()-()-()	1,799.	1,840.	1,878.	1,920.	1,954.	1,980.	2,021.	2,101.	2,161.	2,413.	2,539.	2,791.	2,843.	2,905.
AAC6 cushions	768.	819.	868.	922.	965.	997.	1,052.	1,155.	1,230.	1,438.	1,579.	1,867.	1,928.	1,997.
AAC7-()-()	3,627.	3,727.	3,822.	3,927.	4,013.	4,075.	4,180.	4,381.	4,529.	5,319.	5,647.	6,315.	6,453.	6,616.
AAC7S-()-()-()	2,786.	2,835.	2,881.	2,933.	2,975.	3,006.	3,056.	3,155.	3,227.	3,449.	3,586.	3,867.	3,924.	3,992.
AAC7 cushions	988.	1,049.	1,105.	1,169.	1,221.	1,258.	1,320.	1,441.	1,530.	1,909.	2,099.	2,486.	2,568.	2,662.

Approved KnollTextiles Grades/Fabrics

A Chance Common Ground Commuter Cloth Delite Dristi Hourglass Mariner Prep * Presto * Sonnet Stacks * Trophy	B Argyle * Bank Shot Belize * Cameo Chroma Ferry * Journey Knoll Felt ■ Knoll Hopsack Ludlow Lyric	C continued Nonchalant CR * Prairie * Ransom Ricochet *† Rush Hour Spark * Starry Night Summit Sutton Venue * Westwood * Wide Angle Zipline	D continued Milestone * Palisade Panache * Quark * Sahara Sandpiper CR * Sequin CR * Spot On Stepping Stones * Swing Tilden * Transition *	E Highland Kampala * Katazome Sherman Shima	F Atelier Calais Cotton Velvet * Coco * Cornaro Icon Liberty Rivington * Soon Topography *	G Hampshire * Haze Kamani * Kingston Melange Ultrasuede	H Arno Gezelle Magritte Rosemond	I Cato Dynamic Knoll Velvet *† Ravello *† Rutledge Tudor Vermeer
---	--	--	--	---	---	--	---	--

Spinneybeck Leather

U Vicenza Volo	V Acqua Andes Embossed Tipped España Velluto Pelle	W Alaska Amazon Antique Arizona Forte Sabrina	X Ducale Velour	Y Capri Cervo Copenhagen Cordovan Distressed Marissa Prima Riva Saddle
-----------------------------	--	--	---------------------------	--

* Not approved on frame
† Indicates fabrics without topstitching
■ Knoll Felt/Ivory K1207/1 not approved

Check with your KnollTextiles or Spinneybeck Representative for additions or changes.

Pierre Beucler and Jean-Christophe Poggioli
 Architecture & Associés
Residential Lounge Seating

Designer(s):
 Pierre Beucler and
 Jean-Christophe Poggioli, 2012



description	seat h	arm h	w	d	h	type	textile fabric yds	leather sq ft	weight
AAR4 AA Small Lounge chair, low back, std. wing, same upholstery, frame and cushions	16 1/2"	—	27 3/8"	32 3/4"	30 1/8"		4.5	82	—
AAR4 AA Small Lounge chair, low back, std. wing, combination upholstery, frame and cushions	—	—	—	—	—	frame uph.	2.4	42	—
	—	—	—	—	—	upchg, cushions	2.5	40	—
AAR1 AA Lounge chair, low back, std. wing, arm cushions, same upholstery, frame and cushions	16 1/2"	—	31 1/2"	32 3/4"	30 1/8"		6.4	118	—
AAR1 AA Lounge chair, low back, std. wing, arm cushions, combination upholstery, frame and cushions	—	—	—	—	—	frame uph.	3.1	50	—
	—	—	—	—	—	upchg, cushions	4.7	68	—



Order Code

Example: **AAR1-CU-CV44-H800/2**

AAR1	AA Lounge Chair
CU	Copper legs
CV44	Surround in Cervo, Lessinia
H800/2	Cushions in Cato, Sand

Specify:

1. Pattern number
2. Leg finish
3. Textile selection

Specify with split upholstery:

1. Pattern number
2. Leg finish
3. Textile selection, Surround
4. Textile selection, Cushions

Ordering Information

Leg finishes:

Chrome (suffix C)
 Copper (suffix CU)

Copper leg upcharge:

Copper leg finish is available at an upcharge of \$382 list. Use suffix CU to specify.

Upholstery/ COM information:

Prices shown includes fabric or leather upholstery. Contact your Knoll representative for colors. Only approved KnollTextiles and Spinneybeck leathers may be ordered.

Customer's Own Material is available pending approval. For approval requirements, processing instructions and ordering information please see page 18.

Maintenance:

See pages 28-29.

Construction

Frame:

Constructed in two formed plywood frames, back and seat, giving the pieces their architectural form. Frames are softened with highly resilient urethane foam wrapping.

Upholstery:

Interior loose cushions are available in either residential or contract versions. Contract cushions provide a tailored look for high use areas, while residential cushions convey a relaxed aesthetic. For units with combination upholstery, add list price of surround in appropriate grade with the list price of cushions to obtain total list price for item.

Cushion fill:

"Residential" back cushion is 100% polyester fiber and the seat is a multi-density urethane foam.

Legs:

Machined steel legs feature height adjustable feet for leveling.

pattern no.	grades A	COM B	C	D	E	F	G	H	I	COL U	V	W	X	Y
AAR4-(-)(-)	\$3,865.	\$3,964.	\$4,060.	\$4,165.	\$4,251.	\$4,314.	\$4,419.	\$4,620.	\$4,767.	\$5,827.	\$6,190.	\$6,930.	\$7,083.	\$7,263.
AAR4S-(-)(-)(-)	2,923.	2,976.	3,027.	3,083.	3,128.	3,161.	3,218.	3,325.	3,403.	3,878.	4,063.	4,442.	4,522.	4,612.
AAR4 cushions	1,157.	1,211.	1,265.	1,323.	1,371.	1,406.	1,464.	1,576.	1,657.	2,027.	2,204.	2,566.	2,641.	2,727.
AAR1-(-)(-)	4,247.	4,389.	4,525.	4,674.	4,797.	4,884.	5,034.	5,319.	5,529.	6,993.	7,516.	8,580.	8,801.	9,059.
AAR1S-(-)(-)(-)	3,146.	3,215.	3,281.	3,353.	3,411.	3,455.	3,527.	3,666.	3,768.	4,255.	4,477.	4,928.	5,022.	5,131.
AAR1 cushions	1,382.	1,487.	1,587.	1,696.	1,787.	1,851.	1,960.	2,169.	2,325.	2,815.	3,116.	3,729.	3,857.	4,006.

Approved KnollTextiles Grades/Fabrics

A Chance Common Ground Commuter Cloth Delite Dristi Hourglass Mariner Prep * Presto * Sonnet Stacks * Trophy	B Argyle * Bank Shot Belize * Cameo Chroma Ferry * Journey Knoll Felt ■ Knoll Hopsack Ludlow Lyric	C Atlas * Biota * Charm *† Circa * Classic Boucle Decade * Earthwork Enmesh * Entourage Hudson Hula Hoop Kora CR * Lagos	E Highland Kampala * Katazome Sherman Shima	F Atelier Calais Cotton Velvet * Coco * Cornaro Icon Liberty Rivington * Soon Topography *	G Hampshire * Haze Kamani * Kingston Melange Ultrasuede	H Arno Gezelle Magritte Rosemond	I Cato Dynamic Knoll Velvet *† Ravello *† Rutledge Tudor Vermeer	U Vicenza Volo	V Acqua Andes Embossed Tipped España Velluto Pelle	W Alaska Amazon Antique Arizona Forte Sabrina	X Ducale Velour	Y Capri Cervo Copenhagen Cordovan Distressed Marissa Prima Riva Saddle
---	--	--	---	---	--	---	--	-----------------------------	--	--	---------------------------	--

Spinneybeck Leather

X Ducale Velour	Y Capri Cervo Copenhagen Cordovan Distressed Marissa Prima Riva Saddle
---------------------------	--

* Not approved on frame
† Indicates fabrics without topstitching
■ Knoll Felt/Ivory K1207/1 not approved

Check with your KnollTextiles or Spinneybeck Representative for additions or changes.

Pierre Beucler and Jean-Christophe Poggioli
 Architecture & Associés
Residential Lounge Seating

Designer(s):
 Pierre Beucler and
 Jean-Christophe Poggioli, 2012



description	seat h	arm h	w	d	h	type	textile fabric yds	leather sq ft	weight
AAR2 AA Settee, low back, std. wing, arms, arm cushions, same upholstery, frame and cushions	16 1/2"	—	69 1/2"	32 3/4"	30 1/8"		9.5	177	—
AAR2 AA Settee, low back, std. wing, arms, arm cushions, combination upholstery, frame and cushions	—	—	—	—	—	frame uph.	4.3	76	—
	—	—	—	—	—	upchg. cushions	6.7	101	—
AAR3 AA Sofa, low back, std. wing, arms, arm cushions, same upholstery, frame and cushions	16 1/2"	—	97"	32 3/4"	30 1/8"		12.5	231	—
AAR3 AA Sofa, low back, std. wing, arms, arm cushions, combination upholstery, frame and cushions	—	—	—	—	—	frame uph.	5.4	93	—
	—	—	—	—	—	upchg. cushions	8.5	138	—

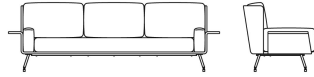

Order Code

Example: **AAR1-CU-CV44-H800/2**

AAR1	AA Lounge Chair
CU	Copper legs
CV44	Surround in Cervo, Lessinia
H800/2	Cushions in Cato, Sand

Specify:

1. Pattern number
2. Leg finish
3. Textile selection

Specify with split upholstery:

1. Pattern number
2. Leg finish
3. Textile selection, Surround
4. Textile selection, Cushions

Ordering Information

Leg finishes:

Chrome (suffix C)
 Copper (suffix CU)

Copper leg upcharge:

Copper leg finish is available at an upcharge of \$382 list. Use suffix CU to specify.

Upholstery/ COM information:

Prices shown includes fabric or leather upholstery. Contact your Knoll representative for colors. Only approved KnollTextiles and Spinneybeck leathers may be ordered.

Customer's Own Material is available pending approval. For approval requirements, processing instructions and ordering information please see page 18.

Maintenance:

See pages 28-29.

Construction

Frame:

Constructed in two formed plywood frames, back and seat, giving the pieces their architectural form. Frames are softened with highly resilient urethane foam wrapping.

Upholstery:

Interior loose cushions are available in either residential or contract versions. Contract cushions provide a tailored look for high use areas, while residential cushions convey a relaxed aesthetic. For units with combination upholstery, add list price of surround in appropriate grade with the list price of cushions to obtain total list price for item.

Cushion fill:

"Residential" back cushion is 100% polyester fiber and the seat is a multi-density urethane foam.

Legs:

Machined steel legs feature height adjustable feet for leveling.

pattern no.	grades A	COM B	C	D	E	F	G	H	I	COL U	V	W	X	Y
AAR2-(-)(-)	\$6,026.	\$6,237.	\$6,439.	\$6,660.	\$6,841.	\$6,973.	\$7,195.	\$7,618.	\$7,930.	\$10,178.	\$10,963.	\$12,559.	\$12,891.	\$13,278.
AAR2S-(-)(-)(-)	4,435.	8,775.	4,623.	4,723.	4,805.	4,865.	4,964.	5,156.	5,297.	6,134.	6,470.	7,155.	7,299.	7,464.
AAR2 cushions	1,999.	2,149.	2,291.	2,446.	2,575.	2,667.	2,823.	3,122.	3,342.	4,138.	4,586.	5,496.	5,687.	5,907.
AAR3-(-)(-)	7,741.	8,021.	8,285.	8,578.	8,816.	8,988.	9,279.	9,837.	10,249.	13,150.	14,175.	16,258.	16,691.	17,196.
AAR3S-(-)(-)(-)	5,595.	5,715.	5,830.	5,955.	6,058.	6,134.	6,259.	6,500.	6,679.	7,659.	8,070.	8,910.	9,085.	9,288.
AAR3 cushions	2,639.	2,827.	3,008.	3,206.	3,368.	3,487.	3,684.	4,063.	4,342.	5,597.	6,210.	7,454.	7,713.	8,014.

Approved KnollTextiles Grades/Fabrics

A Chance Common Ground Commuter Cloth Delite Dristi Hourglass Mariner Prep * Presto * Sonnet Stacks * Trophy	B Argyle * Bank Shot Belize * Cameo Chroma Ferry * Journey Knoll Felt ■ Knoll Hopsack Ludlow Lyric	C Atlas * Biota * Charm *† Circa * Classic Boucle Decade * Earthwork Enmesh * Entourage Hudson Hula Hoop Kora CR * Lagos	E Highland Kampala * Katazome Sherman Shima	F Atelier Calais Cotton Velvet * Coco * Cornaro Icon Liberty Rivington * Soon Topography *	G Hampshire * Haze Kamani * Kingston Melange Ultrasuede	H Arno Gezelle Magritte Rosemond	I Cato Dynamic Knoll Velvet *† Ravello *† Rutledge Tudor Vermeer	U Vicenza Volo	V Acqua Andes Embossed Tipped España Velluto Pelle	W Alaska Amazon Antique Arizona Forte Sabrina	X Ducale Velour	Y Capri Cervo Copenhagen Cordovan Distressed Marissa Prima Riva Saddle
---	--	--	---	---	--	---	--	-----------------------------	--	--	---------------------------	--



Spinneybeck Leather

X Ducale Velour	Y Capri Cervo Copenhagen Cordovan Distressed Marissa Prima Riva Saddle
---------------------------	--

* Not approved on frame
† Indicates fabrics without topstitching
■ Knoll Felt/Ivory K1207/1 not approved

Check with your KnollTextiles or Spinneybeck Representative for additions or changes.

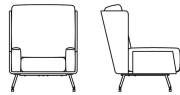
Pierre Beucler and Jean-Christophe Poggioli
 Architecture & Associés
Residential Lounge Seating

	description	seat h	arm h	w	d	h	type	textile fabric yds	leather sq ft	weight
Designer(s): Pierre Beucler and Jean-Christophe Poggioli, 2012 	AAR8 AA Lounge chair, high back, std. wing, arm cushions, same upholstery, frame and cushions 	16 1/2"	–	31 1/2"	36"	36 7/8"		7.3	132	–
	AAR8 AA Lounge chair, high back, std. wing, arm cushions, combination upholstery, frame and cushions	–	–	–	–	–	–	frame uph.	3.6	60
		–	–	–	–	–	upchg, cushions	4.5	72	–
	AAR9 AA Settee, high back, std. wing, arms, arm cushions, same upholstery, frame and cushions 	16 1/2"	–	69 1/2"	36"	36 7/8"		11.2	203	–
	AAR9 AA Settee, high back, std. wing, arms, arm cushions, combination upholstery, frame and cushions	–	–	–	–	–	frame uph.	5	89	–
		–	–	–	–	–	upchg, cushions	6.8	114	–

Order Code

<i>Example:</i>	AAR9-C-PR34-K128/3
AAR9	AA Settee, high back
C	Chrome legs
PR34	Surround in Prima, Scarlatti
K128/3	Cushions in Arno, Obsidian

Specify:

1. Pattern number
2. Leg finish
3. Textile selection

Specify with split upholstery:

1. Pattern number
2. Leg finish
3. Textile selection, Surround
4. Textile selection, Cushions

Ordering Information

Leg finishes:

Chrome (suffix C)
 Copper (suffix CU)

Copper leg upcharge:

Copper leg finish is available at an upcharge of \$382 list. Use suffix CU to specify.

Upholstery/ COM information:

Prices shown includes fabric or leather upholstery. Contact your Knoll representative for colors. Only approved KnollTextiles and Spinneybeck leathers may be ordered.

Customer's Own Material is available pending approval. For approval requirements, processing instructions and ordering information please see page 18.

Maintenance:

See pages 28-29.

Construction

Frame:

Constructed in two formed plywood frames, back and seat, giving the pieces their architectural form. Frames are softened with highly resilient urethane foam wrapping.

Upholstery:

Interior loose cushions are available in either residential or contract versions. Contract cushions provide a tailored look for high use areas, while residential cushions convey a relaxed aesthetic. For units with combination upholstery, add list price of surround in appropriate grade with the list price of cushions to obtain total list price for item.

Cushion fill:

"Residential" back cushion is 100% polyester fiber and the seat is a multi-density urethane foam.

Legs:

Machined steel legs feature height adjustable feet for leveling.

pattern no.	grades A	COM B	C	D	E	F	G	H	I	COL U	V	W	X	Y
AAR8-(-)(-)	\$4,326.	\$4,489.	\$4,643.	\$4,814.	\$4,953.	\$5,054.	\$5,225.	\$5,550.	\$5,791.	\$7,366.	\$7,952.	\$9,142.	\$9,391.	\$9,678.
AAR8S-(-)(-)(-)	3,192.	3,272.	3,349.	3,432.	3,501.	3,550.	3,635.	3,795.	3,914.	4,522.	4,787.	5,329.	5,441.	5,573.
AAR8 cushions	1,375.	1,476.	1,571.	1,676.	1,762.	1,824.	1,929.	2,129.	2,277.	2,922.	3,241.	3,890.	4,026.	4,183.
AAR9-(-)(-)	6,307.	6,556.	6,794.	7,057.	7,270.	7,424.	7,685.	8,184.	8,553.	11,003.	11,905.	13,734.	14,116.	14,560.
AAR9S-(-)(-)(-)	4,595.	4,706.	4,812.	4,929.	5,024.	5,093.	5,210.	5,433.	5,597.	6,576.	6,970.	7,772.	7,940.	8,134.
AAR9 cushions	2,061.	2,212.	2,357.	2,515.	2,645.	2,739.	2,897.	3,201.	3,425.	4,523.	5,027.	6,055.	6,270.	6,519.

Approved KnollTextiles Grades/Fabrics

A Chance Common Ground Commuter Cloth Delite Dristi Hourglass Mariner Prep * Presto * Sonnet Stacks * Trophy	B Argyle * Bank Shot Belize * Cameo Chroma Ferry * Journey Knoll Felt ■ Knoll Hopsack Ludlow Lyric	B continued Nonchalant CR * Pogo * Prairie * Ransom Ricochet *† Rush Hour Spark * Starry Night Summit Sutton Venue * Westwood * Wide Angle Zipline	C continued Milestone * Palisade Panache * Quark * Sahara Sandpiper CR * Sequin CR * Spot On Stepping Stones * Swing Tilden * Transition *	D Eclat Weave * Menagerie Satellite *	C Atlas * Biota * Charm *† Circa * Classic Boucle Decade * Earthwork Enmesh * Entourage Hudson Hula Hoop Kora CR * Lagos	E Highland Kampala * Katazome Sherman Shima	F Atelier Calais Cotton Velvet * Coco * Cornaro Icon Liberty Rivington * Soon Topography *	G Hampshire * Haze Kamani * Kingston Melange Ultrasuede	H Arno Gezelle Magritte Rosemond	I Cato Dynamic Knoll Velvet *† Ravello *† Rutledge Tudor Vermeer	U Vicenza Volo	V Acqua Andes Embossed Tipped España Velluto Pelle	W Alaska Amazon Antique Arizona Forte Sabrina	X Ducale Velour	Y Capri Cervo Copenhagen Cordovan Distressed Marissa Prima Riva Saddle
---	--	---	---	---	--	---	---	--	---	--	-----------------------------	--	--	---------------------------	--

Spinneybeck Leather

U Vicenza Volo	V Acqua Andes Embossed Tipped España Velluto Pelle	W Alaska Amazon Antique Arizona Forte Sabrina	X Ducale Velour	Y Capri Cervo Copenhagen Cordovan Distressed Marissa Prima Riva Saddle
-----------------------------	--	--	---------------------------	--

* Not approved on frame
† Indicates fabrics without topstitching
■ Knoll Felt/Ivory K1207/1 not approved

Check with your KnollTextiles or Spinneybeck Representative for additions or changes.

Pierre Beucler and Jean-Christophe Poggioli
 Architecture & Associés
 Residential Lounge Seating

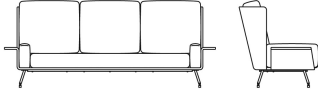
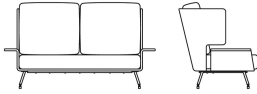
	description	seat h	arm h	w	d	h	type	textile fabric yds	leather sq ft	weight
Designer(s): Pierre Beucler and Jean-Christophe Poggioli, 2012 	AAR10 AA Sofa, high back, std. wing, arms, arm cushions, same upholstery, frame and cushions 	16 1/2"	–	97"	36"	36 7/8"		13.8	243	–
	AAR10 AA Sofa, high back, std. wing, arms, arm cushions, combination upholstery, frame and cushions	–	–	–	–	–	–	frame uph.	6.1	110
		–	–	–	–	–	upchg, cushions	8.6	157	–
	AAR11 AA Settee, high back, large wing, arms, same upholstery, frame and cushions 	16 1/2"	–	69 1/2"	36"	36 7/8"		10.3	190	–
	AAR11 AA Settee, high back, large wing, arms, combination upholstery, frame and cushions	–	–	–	–	–	frame uph.	5.5	97	–
		–	–	–	–	–	upchg, cushions	5	93	–

Order Code

<i>Example:</i>	AAR9-C-PR34-K128/3
AAR9	AA Settee, high back
C	Chrome legs
PR34	Surround in Prima, Scarlatti
K128/3	Cushions in Arno, Obsidian

Specify:

1. Pattern number
2. Leg finish
3. Textile selection

Specify with split upholstery:

1. Pattern number
2. Leg finish
3. Textile selection, Surround
4. Textile selection, Cushions

Ordering Information

Leg finishes:

Chrome (suffix C)
 Copper (suffix CU)

Copper leg upcharge:

Copper leg finish is available at an upcharge of \$382 list. Use suffix CU to specify.

Upholstery/ COM information:

Prices shown includes fabric or leather upholstery. Contact your Knoll representative for colors. Only approved KnollTextiles and Spinneybeck leathers may be ordered.

Customer's Own Material is available pending approval. For approval requirements, processing instructions and ordering information please see page 18.

Maintenance:

See pages 28-29.

Construction

Frame:

Constructed in two formed plywood frames, back and seat, giving the pieces their architectural form. Frames are softened with highly resilient urethane foam wrapping.

Upholstery:

Interior loose cushions are available in either residential or contract versions. Contract cushions provide a tailored look for high use areas, while residential cushions convey a relaxed aesthetic. For units with combination upholstery, add list price of surround in appropriate grade with the list price of cushions to obtain total list price for item.

Cushion fill:

"Residential" back cushion is 100% polyester fiber and the seat is a multi-density urethane foam.

Legs:

Machined steel legs feature height adjustable feet for leveling.

pattern no.	grades A	COM B	C	D	E	F	G	H	I	COL U	V	W	X	Y
AAR10-(-)-()	\$8,056.	\$8,363.	\$8,656.	\$8,977.	\$9,241.	\$9,432.	\$9,754.	\$10,368.	\$10,822.	\$13,680.	\$14,758.	\$16,949.	\$17,405.	\$17,936.
AAR10S-(-)-(-)	5,794.	5,930.	6,058.	6,201.	6,318.	6,402.	6,545.	6,817.	7,016.	8,240.	8,728.	9,720.	9,927.	10,166.
AAR10 cushions	2,720.	2,911.	3,093.	3,294.	3,459.	3,577.	3,778.	4,161.	4,444.	6,153.	6,850.	8,265.	8,559.	8,903.
AAR11-(-)-()	6,809.	7,038.	7,256.	7,497.	7,694.	7,836.	8,076.	8,535.	8,874.	11,237.	12,080.	13,793.	14,149.	14,565.
AAR11S-(-)-(-)	5,005.	5,127.	5,244.	5,372.	5,478.	5,553.	5,681.	5,927.	6,108.	7,154.	7,584.	8,459.	8,641.	8,853.
AAR11 cushions	2,126.	2,237.	2,343.	2,461.	2,555.	2,624.	2,742.	2,964.	3,128.	4,176.	4,589.	5,427.	5,601.	5,805.

Approved KnollTextiles Grades/Fabrics

A Chance Common Ground Commuter Cloth Delite Dristi Hourglass Mariner Prep * Presto * Sonnet Stacks * Trophy	B Argyle * Bank Shot Belize * Cameo Chroma Ferry * Journey Knoll Felt ■ Knoll Hopsack Ludlow Lyric	B continued Nonchalant CR * Pogo * Prairie * Ransom Ricochet *† Rush Hour Spark * Starry Night Summit Sutton Venue * Westwood * Wide Angle Zipline	C Atlas * Biota * Charm *† Circa * Classic Boucle Decade * Earthwork Enmesh * Entourage Hudson Hula Hoop Kora CR * Lagos	C continued Milestone * Palisade Panache * Quark * Sahara Sandpiper CR * Sequin CR * Spot On Stepping Stones * Swing Tilden * Transition *	D Eclat Weave * Menagerie Satellite *	E Highland Kampala * Katazome Sherman Shima	F Atelier Calais Cotton Velvet * Coco * Cornaro Icon Liberty Rivington * Soon Topography *	G Hampshire * Haze Kamani * Kingston Melange Ultrasuede	H Arno Gezelle Magritte Rosemond	I Cato Dynamic Knoll Velvet *† Ravello *† Rutledge Tudor Vermeer
---	--	---	--	---	---	---	---	--	---	--

Spinneybeck Leather

U Vicenza Volo	V Acqua Andes Embossed Tipped España Velluto Pelle	W Alaska Amazon Antique Arizona Forte Sabrina	X Ducale Velour	Y Capri Cervo Copenhagen Cordovan Distressed Marissa Prima Riva Saddle
-----------------------------	--	--	---------------------------	--

* Not approved on frame
† Indicates fabrics without topstitching
■ Knoll Felt/Ivory K1207/1 not approved

Check with your KnollTextiles or Spinneybeck Representative for additions or changes.

Pierre Beucler and Jean-Christophe Poggioli
 Architecture & Associés
 Residential Lounge Seating

Designer(s):
 Pierre Beucler and
 Jean-Christophe Poggioli, 2012



description	seat h	arm h	w	d	h	type	leather sq ft	textile fabric yds	weight
AAR12L AA Chaise, high back, large wing, left arm, same upholstery, frame and cushions	16 1/2"	—	35 1/2"	69"	36 7/8"		150	8.3	—
AAR12L AA Chaise, high back, large wing, left arm, combination upholstery, frame and cushions	—	—	—	—	—	frame uph.	86	5.3	—
	—	—	—	—	—	upchg, cushions	64	4.4	—
AAR12R AA Chaise, high back, large wing, right arm, same upholstery, frame and cushions	16 1/2"	—	35 1/2"	69"	36 7/8"		150	8.3	—
AAR12R AA Chaise, high back, large wing, right arm, combination upholstery, frame and cushions	—	—	—	—	—	frame uph.	86	5.3	—
	—	—	—	—	—	upchg, cushions	64	4.4	—

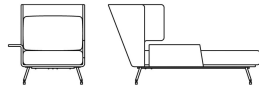

Order Code

Example: **AAR12L-CU-RA1805-K1021/5**

AAR12L	AA Chaise, left arm
CU	Copper legs
RA1805	Surround in Riva, Labbo
K1021/5	Cushions in Ultrasuede, Aztec

Specify:

1. Pattern number
2. Leg finish
3. Textile selection

Specify with split upholstery:

1. Pattern number
2. Leg finish
3. Textile selection, Surround
4. Textile selection, Cushions

Ordering Information

Leg finishes:

Chrome (suffix C)
 Copper (suffix CU)

Copper leg upcharge:

Copper leg finish is available at an upcharge of \$382 list. Use suffix CU to specify.

Upholstery/ COM information:

Prices shown includes fabric or leather upholstery. Contact your Knoll representative for colors. Only approved KnollTextiles and Spinneybeck leathers may be ordered.

Customer's Own Material is available pending approval. For approval requirements, processing instructions and ordering information please see page 18.

Maintenance:

See pages 28-29.

Construction

Frame:

Constructed in two formed plywood frames, back and seat, giving the pieces their architectural form. Frames are softened with highly resilient urethane foam wrapping.

Upholstery:

Interior loose cushions are available in either residential or contract versions. Contract cushions provide a tailored look for high use areas, while residential cushions convey a relaxed aesthetic. For units with combination upholstery, add list price of surround in appropriate grade with the list price of cushions to obtain total list price for item.

Cushion fill:

"Residential" back cushion is 100% polyester fiber and the seat is a multi-density urethane foam.

Legs:

Machined steel legs feature height adjustable feet for leveling.

pattern no.	grades A	COM B	C	D	E	F	G	H	I	COL U	V	W	X	Y
AAR12L-(-)(-)	\$6,545.	\$6,730.	\$6,906.	\$7,100.	\$7,258.	\$7,372.	\$7,566.	\$7,936.	\$8,209.	\$10,094.	\$10,759.	\$12,113.	\$12,393.	\$12,722.

AAR12LS-(-)(-)	4,980.	5,097.	5,210.	5,334.	5,435.	5,508.	5,632.	5,868.	6,042.	6,864.	7,246.	8,022.	8,182.	8,371.
AAR12L cushions	1,967.	2,065.	2,159.	2,262.	2,345.	2,406.	2,509.	2,706.	2,850.	3,324.	3,607.	4,184.	4,305.	4,445.

AAR12R-(-)(-)	6,545.	6,730.	6,906.	7,100.	7,258.	7,372.	7,566.	7,936.	8,209.	10,094.	10,759.	12,113.	12,393.	12,722.
----------------------	--------	--------	--------	--------	--------	--------	--------	--------	--------	---------	---------	---------	---------	---------

AAR12RS-(-)(-)	4,980.	5,097.	5,210.	5,334.	5,435.	5,508.	5,632.	5,868.	6,042.	6,864.	7,246.	8,022.	8,182.	8,371.
AAR12R cushions	1,967.	2,065.	2,159.	2,262.	2,345.	2,406.	2,509.	2,706.	2,850.	3,324.	3,607.	4,184.	4,305.	4,445.

Approved KnollTextiles Grades/Fabrics

A Chance Common Ground Commuter Cloth Delite Dristi Hourglass Mariner Prep * Presto * Sonnet Stacks * Trophy	B Argyle * Bank Shot Belize * Cameo Chroma Ferry * Journey Knoll Felt ■ Knoll Hopsack Ludlow Lyric	C Atlas * Biota * Charm *† Circa * Classic Boucle Decade * Earthwork Enmesh * Entourage Hudson Hula Hoop Kora CR * Lagos	E Highland Kampala * Katazome Sherman Shima	F Atelier Calais Cotton Velvet * Coco * Cornaro Icon Liberty Rivington * Soon Topography *	G Hampshire * Haze Kamani * Kingston Melange Ultrasuede	H Arno Gezelle Magritte Rosemond	I Cato Dynamic Knoll Velvet *† Ravello *† Rutledge Tudor Vermeer	U Vicenza Volo	V Acqua Andes Embossed Tipped España Velluto Pelle	W Alaska Amazon Antique Arizona Forte Sabrina	X Ducale Velour	Y Capri Cervo Copenhagen Cordovan Distressed Marissa Prima Riva Saddle
---	--	--	---	---	--	---	--	-----------------------------	--	--	---------------------------	--





Spinneybeck Leather

U Vicenza Volo	V Acqua Andes Embossed Tipped España Velluto Pelle	W Alaska Amazon Antique Arizona Forte Sabrina	X Ducale Velour	Y Capri Cervo Copenhagen Cordovan Distressed Marissa Prima Riva Saddle
-----------------------------	--	--	---------------------------	--

* Not approved on frame
† Indicates fabrics without topstitching
■ Knoll Felt/Ivory K1207/1 not approved

Check with your KnollTextiles or Spinneybeck Representative for additions or changes.

Pierre Beucler and Jean-Christophe Poggioli
 Architecture & Associés
 Residential Lounge Seating

	description	seat h	arm h	w	d	h	type	textile fabric yds	leather sq ft	weight
<i>Designer(s):</i> Pierre Beucler and Jean-Christophe Poggioli, 2012	AAR5 AA Small Ottoman, same upholstery, frame and cushions 	–	–	27 1/2"	24 1/2"	16"		2.2	40	–
	AAR5 AA Small Ottoman, combination upholstery, frame and cushions	–	–	–	–	–	frame uph. upchg, cushions	1.2 1.3	18 22	– –
	AAR6 AA Medium Ottoman, same upholstery, frame and cushions 	–	–	31 1/8"	29 1/2"	16"		3.3	60	–
	AAR6 AA Medium Ottoman, combination upholstery, frame and cushions	–	–	–	–	–	frame uph. upchg, cushions	1.8 2.3	28 32	– –
	AAR7 AA Large Ottoman, same upholstery, frame and cushions 	–	–	59"	29 1/2"	16 1/2"		4.5	74	–
	AAR7 AA Large Ottoman, combination upholstery, frame and cushions	–	–	–	–	–	frame uph. upchg, cushions	2.2 2.7	31 43	– –

Order Code

<i>Example:</i>	AAR5-C-SL69
AAR5	AA Small Ottoman
C	Chrome legs
SL69	Saddle, Seal Bay

Specify:

1. Pattern number
2. Leg finish
3. Textile selection

Specify with split upholstery:

1. Pattern number
2. Leg finish
3. Textile selection, Surround
4. Textile selection, Cushions

Ordering Information

Leg finishes:

- Chrome (suffix C)
- Copper (suffix CU)

Copper leg upcharge:

Copper leg finish is available at an upcharge of \$382 list. Use suffix CU to specify.

Upholstery/ COM information:

Prices shown includes fabric or leather upholstery. Contact your Knoll representative for colors. Only approved KnollTextiles and Spinneybeck leathers may be ordered.

Customer's Own Material is available pending approval. For approval requirements, processing instructions and ordering information please see page 18.

Maintenance:

See pages 28-29.

Construction

Frame:

Constructed in two formed plywood frames, back and seat, giving the pieces their architectural form. Frames are softened with highly resilient urethane foam wrapping.

Upholstery:

Interior loose cushions are available in either residential or contract versions. Contract cushions provide a tailored look for high use areas, while residential cushions convey a relaxed aesthetic. For units with combination upholstery, add list price of surround in appropriate grade with the list price of cushions to obtain total list price for item.

Cushion fill:

"Residential" back cushion is 100% polyester fiber and the seat is a multi-density urethane foam.

Legs:

Machined steel legs feature height adjustable feet for leveling.

pattern no.	grades A	COM B	C	D	E	F	G	H	I	COL U	V	W	X	Y
AAR5-(-)(-)	\$2,272.	\$2,323.	\$2,369.	\$2,419.	\$2,463.	\$2,492.	\$2,544.	\$2,642.	\$2,714.	\$3,259.	\$3,436.	\$3,797.	\$3,873.	\$3,959.
AAR5S-(-)(-)(-)	1,728.	1,755.	1,780.	1,809.	1,831.	1,848.	1,876.	1,930.	1,969.	2,129.	2,209.	2,372.	2,405.	2,445.
AAR5 cushions	685.	715.	743.	773.	798.	816.	846.	904.	947.	1,168.	1,266.	1,464.	1,506.	1,554.
AAR6-(-)(-)	2,394.	2,467.	2,537.	2,614.	2,677.	2,722.	2,800.	2,946.	3,055.	3,812.	4,078.	4,620.	4,732.	4,864.
AAR6S-(-)(-)(-)	1,799.	1,840.	1,878.	1,920.	1,954.	1,980.	2,021.	2,101.	2,161.	2,413.	2,539.	2,791.	2,843.	2,905.
AAR6 cushions	768.	819.	868.	922.	965.	997.	1,052.	1,155.	1,230.	1,438.	1,579.	1,867.	1,928.	1,997.
AAR7-(-)(-)	3,627.	3,727.	3,822.	3,927.	4,013.	4,075.	4,180.	4,381.	4,529.	5,319.	5,647.	6,315.	6,453.	6,616.
AAR7S-(-)(-)(-)	2,786.	2,835.	2,881.	2,933.	2,975.	3,006.	3,056.	3,155.	3,227.	3,449.	3,586.	3,867.	3,924.	3,992.
AAR7 cushions	988.	1,049.	1,105.	1,169.	1,221.	3,592.	1,320.	1,441.	1,530.	1,909.	2,099.	2,486.	2,568.	2,662.

Approved KnollTextiles Grades/Fabrics

A Chance Common Ground Commuter Cloth Delite Dristi Hourglass Mariner Prep * Presto * Sonnet Stacks * Trophy	B Argyle * Bank Shot Belize * Cameo Chroma Ferry * Journey Knoll Felt ■ Knoll Hopsack Ludlow Lyric	C continued Nonchalant CR * Prairie * Ransom Ricochet *† Rush Hour Spark * Starry Night Summit Sutton Venue * Westwood * Wide Angle Zipline	D continued Milestone * Palisade Panache * Quark * Sahara Sandpiper CR * Sequin CR * Spot On Stepping Stones * Swing Tilden * Transition *	E Highland Kampala * Katazome Sherman Shima	F Atelier Calais Cotton Velvet * Coco * Cornaro Icon Liberty Rivington * Soon Topography *	G Hampshire * Haze Kamani * Kingston Melange Ultrasuede	H Arno Gezelle Magritte Rosemond	I Cato Dynamic Knoll Velvet *† Ravello *† Rutledge Tudor Vermeer
---	--	--	--	---	---	--	---	--

Spinneybeck Leather

U Vicenza Volo	V Acqua Andes Embossed Tipped España Velluto Pelle	W Alaska Amazon Antique Arizona Forte Sabrina	X Ducale Velour	Y Capri Cervo Copenhagen Cordovan Distressed Marissa Prima Riva Saddle
-----------------------------	--	--	---------------------------	--

* Not approved on frame
† Indicates fabrics without topstitching
■ Knoll Felt/Ivory K1207/1 not approved



Check with your KnollTextiles or Spinneybeck Representative for additions or changes.

Cini Boeri

Lounge Collection

Designer(s):
Cini Boeri, 2008

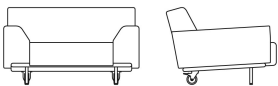
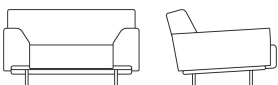
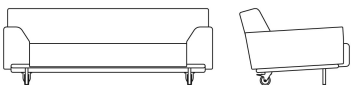
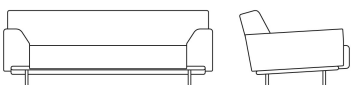

description	seat h	arm h	w	d	h	textile fabric yds.	req. leather sq. ft.	weight
CB1-C Lounge chair 	16 3/8"	22 3/16"	53 3/8"	43 3/8"	30 7/16"	6.2	145	113 lbs.
CB1-L Lounge chair with four standard legs 	16 3/8"	22 3/16"	53 3/8"	43 3/8"	30 7/16"	6.2	145	113 lbs.
CB2-C Sofa 	16 3/8"	22 3/16"	83"	43 3/8"	30 7/16"	7.8	200	142 lbs.
CB2-L Sofa with four standard legs 	16 3/8"	22 3/16"	83"	43 3/8"	30 7/16"	7.8	200	142 lbs.
CB3 Ottoman 			33"	33"	13 1/2"	3.6	50	50 lbs.

Order Code

Example: **CB2-L-K1152/1**

CB2	Cini Boeri sofa
L	Four standard legs
K1152/1	Stirling, Gable

Ordering Information

Upholstery/COM information:
Prices shown include fabric or leather upholstery. Contact your Knoll representative for colors. Only approved KnollTextiles and Spinneybeck leathers may be ordered.

Customer's Own Material in textile applications is limited and no COL leather applications are approved.
For approval requirements, processing instructions and ordering information, please see page 13.

Pillow:
Throw pillows for the Cini Boeri Lounge Collection are available in two sizes. Pillows are composed of recycled polyester. Since pillow is not fitted it is available in fabric only.

Maintenance:
See pages 28-29.

Note:
The Cini Boeri Lounge Collection is Greenguard certified.

Construction

Frame:
Formed steel tubing with powder coat finish. Finish color is Dark Grey paint (113).

Legs:
Available with four legs or a combination of legs and casters. Fixed rear locking casters are standard on Lounge Chair and Sofa. Swivel casters on ottoman do not lock.

Seat Cushion:
Seat cushion is made of highly-resilient polyurethane open-cell Cal 117 foam. Cushion is not reversible.

Upholstery:
Textile application must be railroaded. Textile applications are standard with single needle top stitch. Leather applications are standard with double needle top stitch. Please note that ottoman stitch detail is applicable to top seams only; side seams for both textile and leather are single blind seams.

Specify:

1. Pattern number
2. Leg selection
3. Textile selection

pattern no.	grades					COM					COL				
	A	B	C	D	E	F	G	H	I	U	V	W	X	Y	
CB1-C	\$7,473.	\$7,634.	\$7,809.	\$7,987.	\$8,139.	\$8,240.	\$8,421.	\$8,759.	\$9,013.	\$11,858.	\$12,756.	\$14,365.	\$14,724.	\$15,083.	
CB1-L	7,473.	7,634.	7,809.	7,987.	8,139.	8,240.	8,421.	8,759.	9,013.	11,858.	12,756.	14,365.	14,724.	15,083.	
CB2-C	9,629.	9,850.	10,092.	10,333.	10,542.	10,679.	10,931.	11,394.	11,740.	15,808.	17,044.	19,268.	19,762.	20,256.	
CB2-L	9,629.	9,850.	10,092.	10,333.	10,542.	10,679.	10,931.	11,394.	11,740.	15,808.	17,044.	19,268.	19,762.	20,256.	
CB3-()	2,692.	2,785.	2,888.	2,990.	3,079.	3,137.	3,245.	3,438.	3,585.	3,681.	3,960.	4,460.	4,572.	4,682.	

Approved KnollTextiles Grades/Fabrics

A	Alignment *	Beacon	Bocce	Cat's Cradle *	Common Ground	Commuter Cloth	Delite	Dristi	Heavy Metal *	Hourglass	Mariner	Metaphor **	Monarch *	Prep *	Presto *	Sonnet	Stacks *	Trophy
B	Abacus *	Argyle	Bank Shot	Belize *	Betwixt *	Bistro	Cameo	Chroma	Chronicle *	Close Knit *	Digit *	Dovetail *	Fairway	Ferry	Gala II *	Grandview *	Holbrook ** *	
C	Autobahn *	Axiom *	Biota *	Cairo *	Charm *	Circa *	Classic Boucle											
C continued	Journey	Keaton	Knoll Felt ‡	Knoll Hopsack ‡	Ludlow	Mini Stitch *	Nightlife	Nonchalant CR *	Paradigm *	Pogo *	Pop	Prairie	Radiance	Ransom	Ricochet ‡	Roam *	Rush Hour	Soiree *
C continued	Dahlia CR	Decade *	Durand **	Earthwork ‡	Echo *	Empire Stripe *	Enmesh *	Entourage	Fable CR *	Fibra *	Greenwich *	Hudson *	Kaleidoscope *	Kora CR *	Lagos	Lore CR *	Metro *	Milestone ** *
C continued	Tight Rope *	Tilden	Tower Grid *	Transition *	Treble CR *	Vibe	Zari CR *											
D	Compass CR	Coterie *	Eclat Weave *	Hologram *	Island **	Masquerade *	Menagerie	Origins *	Satelite *	Satin Chisel *	Tara	Theory *	Woodland **	Zoom *				
E	Highland	Ikat Stripe *	Ikat Square *	Kampala	Katazome	Kimono *	Liberty **	Luberon **	Mamba *	Marquee *	Meroe **	Sherman	Shima	Tryst *	Whip			

Spinneybeck Leather

U	Vicenza	Volo
V	Acqua	Andes
V	Espana	Embossed Tipped
V	Hand Tipped	Velluto Pelle
W	Alaska	Amazon
W	Antique	Arizona
W	Derby	Forte
W	Lucente	Sabrina
X	Ducale	Ducale Velour
Y	Capri	Cervo
Y	Copenhagen	Cordovan
Y	Distressed	Marissa
Y	Prima	Riva
Y	Saddle	Salon

* Approved for CB3 ottoman, CBP1 and CBP2 throw pillows only.
 ** Approved for CBP1 and CBP2 throw pillows only.



Check with your KnollTextiles or Spinneybeck Representative for changes or additions.

Cini Boeri

Lounge Collection

Designer(s):
Cini Boeri, 2008



description	seat h	arm h	w	d	h	textile fabric yds.	req. leather sq. ft.	weight
CBP1 Large throw pillow 			31"		24"	2	n/a	
CBP2 Small throw pillow 			24"		18"	1.6	n/a	

Order Code

Example: **CB2-L-K1152/1**

CB2 Cini Boeri sofa

L Four standard legs

K1152/1 Stirling, Gable

Specify:

1. Pattern number
2. Leg selection
3. Textile selection

Ordering Information

Upholstery/COM information:
Prices shown include fabric or leather upholstery. Contact your Knoll representative for colors. Only approved KnollTextiles and Spinneybeck leathers may be ordered.

Customer's Own Material in textile applications is limited and no COL leather applications are approved.
For approval requirements, processing instructions and ordering information, please see page 13.

Pillow:
Throw pillows for the Cini Boeri Lounge Collection are available in two sizes. Pillows are composed of recycled polyester. Since pillow is not fitted it is available in fabric only.

Maintenance:
See pages 28-29.

Note:
The Cini Boeri Lounge Collection is Greenguard certified.

Construction

Frame:
Formed steel tubing with powder coat finish. Finish color is Dark Grey paint (113).

Legs:
Available with four legs or a combination of legs and casters. Fixed rear locking casters are standard on Lounge Chair and Sofa. Swivel casters on ottoman do not lock.

Seat Cushion:
Seat cushion is made of highly-resilient polyurethane open-cell Cal 117 foam. Cushion is not reversible.

Upholstery:
Textile application must be railroaded. Textile applications are standard with single needle top stitch. Leather applications are standard with double needle top stitch. Please note that ottoman stitch detail is applicable to top seams only; side seams for both textile and leather are single blind seams.

pattern no.	grades A	COM B	C	D	E	F	G	H	I	COL U	V	W	X	Y
CBP1-()	\$470.	\$519.	\$569.	\$618.	\$662.	\$692.	\$746.	\$845.	\$917.					
CBP2-()	403.	448.	499.	552.	596.	624.	678.	774.	849.					

Approved KnollTextiles Grades/Fabrics

A	Alignment *	B	Journey	C	continued	C	continued	F	Atelier	H	Arno	U	Vicenza	X	Ducale
	Beacon		Keaton		Dahlia CR		Tight Rope *		Biscayne *		Constance *		Volo		Ducale Velour
	Bocce		Knoll Felt †		Decade *		Tilden		Calais Cotton		Firefly **		V	V	Capri
	Cat's Cradle *		Knoll Hopsack †		Durand **		Tower Grid *		Velvet *		Magritte		Acqua		Cervo
	Common Ground		Ludlow		Earthwork †		Transition *		Century *		Rosemond		Andes		Copenhagen
	Commuter Cloth		Mini Stitch *		Echo *		Treble CR *		Coco *				Espana		Cordovan
	Delite		Nightlife		Empire Stripe *		Vibe		Cornaro		I		Embossed Tipped		Distressed
	Dristi		Nonchalant CR *		Enmesh *		Zari CR *		Eclipse *		Byron **		Hand Tipped		Marissa
	Heavy Metal *		Paradigm *		Entourage				Glider *		Cato		Velluto Pelle		Prima
	Hourlglass		Pogo *		Fable CR *		D		Intrigue *		Diamond Days				Riva
	Mariner		Pop		Fibra *		Compass CR		Mod Plaid *		Digi Velvet **				Saddle
	Metaphor **		Prairie		Greenwich *		Coterie *		Rivington *		Dynamic		W		Salon
	Monarch *		Radiance		Hudson *		Eclat Weave *		Soon		Gates		Alaska		
	Prep *		Ransom		Kaleidoscope *		Hologram *		Topography *		Jaipur **		Amazon		
	Presto *		Ricochet †		Kora CR *		Island **		Totem *		Knoll Velvet		Antique		
	Sonnet		Roam *		Lagos		Masquerade *				Olema		Arizona		
	Stacks *		Rush Hour		Lore CR *		Menagerie		G		Piper		Derby		
	Trophy		Soiree *		Metro *		Origins *				Ravello		Forte		
			Spark *		Milestone **		Satelite *				Rutledge		Lucente		
			Spree *		Moto CR *		Satin Chisel *				Sandis *		Sabrina		
			Starry Night †		Palisade		Tara				Tudor				
			Summit		Panache CR *		Theory *				Vermeer				
			Sutton		Quark *		Woodland **				Walker *				
			Synth		Regard CR *		Zoom *				Worth **				
			Tabloid **		Roundtrip **						Zimba				
			Utmost **		Sahara		E								
			Venue *		Sandpiper *		Highland								
			Versa *		Spectator **		Ikat Stripe *								
			Westwood		Spot On		Ikat Square *								
			Zephyr *		Star Struck *		Kampala								
			Zipline		Stepping Stones		Katazome								
					Swing		Kimono *								
			C				Liberty **								
			Autobahn *				Luberon **								
			Axiom *				Mamba *								
			Biota *				Marquee *								
			Cairo *				Meroe **								
			Charm *				Sherman								
			Circa *				Shima								
			Classic Boucle				Tryst *								
							Whip								

Spinneybeck Leather



U	Vicenza	X	Ducale
	Volo		Ducale Velour
V	Acqua	Y	Capri
	Andes		Cervo
	Espana		Copenhagen
	Embossed Tipped		Cordovan
	Hand Tipped		Distressed
	Velluto Pelle		Marissa
W	Alaska		Prima
	Amazon		Riva
	Antique		Saddle
	Arizona		Salon
	Derby		
	Forte		
	Lucente		
	Sabrina		

* Approved for CB3 ottoman, CBP1 and CBP2 throw pillows only.
 ** Approved for CBP1 and CBP2 throw pillows only.

Check with your KnollTextiles or Spinneybeck Representative for changes or additions.

Marcel Breuer

Cesca Chair

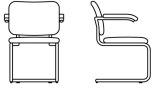
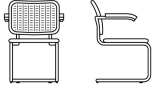
	description	seat h	arm h	w	d	h	textile fabric yds.	req. leather sq. ft.	weight
<p><i>Designer(s):</i> Marcel Breuer, 1928</p>  	50A-7 Arm chair, fully upholstered seat and back 	17 3/4"	27"	23 1/2"	23 1/2"	31 1/2"	1.1	20	17 lbs.
	50AR-7 Replacement seat, back and arms for 50A-7						1.1	20	
	50A-5 Arm chair, wood frame, handwoven cane inset seat and back 	17 3/4"	27"	23 1/2"	23 1/2"	31 1/2"			16 lbs.
	50AR-5 Replacement seat, back, arms for 50A-5								

Order Code

<i>Example:</i>	50A-5-BE
50A-5	Cesca arm chair, cane seat
BE	Ebonized frame
<i>Example:</i>	50C-2-K1106/8
50C-2	Cesca armless chair, fully upholstered
K1106/8	Spencer, Apricot

Note:
Cesca chairs are part of a collection. Please refer to the Wassily lounge chair and Laccio tables on pages 90 and 310.

Specify:

1. Pattern number
2. Seat/back frame finish suffix

For fully upholstered specify:

1. Pattern number
2. Seat/back frame finish suffix
3. Textile selection

Ordering Information

Seat and back finishes:
Clear (suffix B)
Ebonized (suffix BE)

Upholstery/COM information:
Prices shown include fabric or leather upholstery. Contact your Knoll representative for colors. Only approved KnollTextiles and Spinneybeck leathers may be ordered.

Customer's Own Material is available pending approval. For approval requirements, processing instructions and ordering information please see page 18.

Cal 133 Fire Code ▲ :
The Cesca chair complies with California Technical Bulletin 133 with select KnollTextiles. Upcharge applies, see page 18.

Note:
The KnollStudio logo and signature of Marcel Breuer are stamped into the base of the chair.

The Cesca Chair is Greenguard certified.

Maintenance:
See pages 28-29.

Construction

Fully upholstered chairs:
Urethane foam over molded plywood seat and back. Solid hardwood arms. Arms are upholstered.

Cane inset chairs:
Hardwood beech seat/back frames and arms with natural clear lacquer or matte ebonized finish. Handwoven cane insets.

Frame:
1" diameter round steel tube with chrome-plated and polished finish.

Glides:
Opaque plastic; snap-in place design. Glides shipped with each chair for optional in-field insertion.

Replacement seat baskets:
Cesca seat baskets can be replaced in the field by field services or a furniture repair specialist. Seat basket replacements do not ship with hardware and are not pre-drilled. They consist of seat and back for armless chairs; seat, back and arms for arm chair.

pattern no.	cane seat	grades										COL			
		A	B	C	D	E	F	G	H	I	U	V	W	X	Y
50A-7		\$1,411.	\$1,457.	\$1,501.	\$1,530.	\$1,560.	\$1,584.	\$1,613.	\$1,679.	\$1,810.	\$2,205.	\$2,358.	\$2,667.	\$2,748.	\$2,808.
50AR-7		825.	864.	906.	934.	962.	987.	1,011.	1,074.	1,198.	1,577.	1,725.	2,020.	2,094.	2,154.
50A-5-B	2,189.														
50A-5-BE	2,439.														
50AR-5-B	1,502.														
50AR-5-BE	1,749.														

Approved KnollTextiles Grades/Fabrics

A	B	C	C continued
Alignment	Forza	Atlas	Roundtrip
Beacon	Gala II	Autobahn	Sequin CR
Bocce	Grande	Axiom	Sinclair
Chance	Grandview	Baxter	Smart
Common Ground	Journey	Biota	Spectator
Commuter Cloth	Keaton	Charm	Spot On
Delite	Knoll Felt	Circa	Star Struck
Dristi	Knoll Hopsack	Classic Boucle	Stepping Stones
Hourlgass	Lyric	Dahlia CR	Swing
Mariner	Night Life	Decade	Tight Rope
Prep	Nonchalant CR	Durand	Tilden
Presto	Paradigm	Earthwork	Tower Grid
Soliloquy	Petal Pusher	Echo	Transition
Sonnet	Pogo	Empire Stripe	Treble CR
Stacks	Pop	Enmesh	Vibe
Trophy	Prairie	Entourage	Zari CR
B	Prim	Fable CR	D
Abacus	Radiance	Fibra	Coterie
Argyle	Ransom	Greenwich	Eclat Weave
Bank Shot	Ricochet	Hudson	Hologram
Betwixt	Roam	Hula Hoop	In The Loop
Bistro	Rush Hour	Kora CR	Island
Boundary	Soiree	Lagos	Masquerade
Cameo	Spark	Metro	Menagerie
Chroma	Spinoff Nuance	Moto CR	Origins
Chronicle	Spree	Noble	Satellite
Close Knit	Starry Night	Palisade	Satin Chisel
Digit	Summit	Panache CR	Tara
Digital Tape	Sutton	Quark	Theory
Dovetail	Synth		Woodand
Ferry	Tabloid		Zoom
	Venue		E
	Versa		Highland
	Vinyl		Ikat Stripe
	Westwood		Ikat Square
	Wide Angle		Kampala
	Zephyr		Katazome
	Zipline		Luberon
			Mamba
			Marquee
			Sherman
			Shima
			Whip



Spinneybeck Leather

U	X
Vicenza	Ducale Velour
Volo	
V	Y
Acqua	Capri
Andes	Cervo
Embossed Tipped	Copenhagen
España	Distressed
Velluto Pelle	Lucca
	Marissa
W	Riva
Alaska	
Amazon	
Antique	
Arizona	
Derby	
Forte	
Lucente	
Sabrina	
‡ Approved for Cal 133 upholstery	

Check with your KnollTextiles or Spinneybeck Representative for changes or additions.

Marcel Breuer

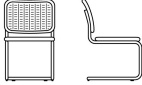
Cesca Chair

	description	seat h	arm h	w	d	h	textile fabric yds.	leather sq. ft.	weight
<p><i>Designer(s):</i> Marcel Breuer, 1928</p> 	<p>50C-1 Armless chair, wood frame handwoven cane inset seat and back</p> 	17 3/4"		18 1/2"	23 1/2"	31 1/2"			11 lbs.
	<p>50CR-1 Replacement seat and back for 50C-1</p>								
	<p>50C-2 Armless chair, fully upholstered seat and back</p> 	17 3/4"		18 1/2"	23 1/2"	31 1/2"	1.1	20	14 lbs.
	<p>50CR-2 Replacement seat, back and arms for 50C-2</p>						1.1	20	

Order Code

<i>Example:</i>	50A-5-BE
50A-5	Cesca arm chair, cane seat
BE	Ebonized frame
<i>Example:</i>	50C-2-K1106/8
50C-2	Cesca armless chair, fully upholstered
K1106/8	Spencer, Apricot

Note:
Cesca chairs are part of a collection. Please refer to the Wassily lounge chair and Laccio tables on pages 90 and 310.

Specify:

1. Pattern number
2. Seat/back frame finish suffix

For fully upholstered specify:

1. Pattern number
2. Seat/back frame finish suffix
3. Textile selection

Ordering Information

Seat and back finishes:
Clear (suffix B)
Ebonized (suffix BE)

Upholstery/COM information:
Prices shown include fabric or leather upholstery. Contact your Knoll representative for colors. Only approved KnollTextiles and Spinneybeck leathers may be ordered.

Customer's Own Material is available pending approval. For approval requirements, processing instructions and ordering information please see page 18.

Cal 133 Fire Code ▲ :
The Cesca chair complies with California Technical Bulltin 133 with select KnollTextiles. Upcharge applies, see page 18.

Note:
The KnollStudio logo and signature of Marcel Breuer are stamped into the base of the chair.

The Cesca Chair is Greenguard certified.

Maintenance:
See pages 28-29.

Construction

Fully upholstered chairs:
Urethane foam over molded plywood seat and back. Solid hardwood arms. Arms are upholstered.

Cane inset chairs:
Hardwood beech seat/back frames and arms with natural clear lacquer or matte ebonized finish. Handwoven cane insets.

Frame:
1" diameter round steel tube with chrome-plated and polished finish.

Glides:
Opaque plastic; snap-in place design. Glides shipped with each chair for optional in-field insertion.

Replacement seat baskets:
Cesca seat baskets can be replaced in the field by field services or a furniture repair specialist. Seat basket replacements do not ship with hardware and are not pre-drilled. They consist of seat and back for armless chairs; seat, back and arms for arm chair.

pattern no.	cane seat	grades	COM											COL				
		A	B	C	D	E	F	G	H	I	U	V	W	X	Y			
50C-1-BE	\$2,251.																	
50C-1-B	2,007.																	
50CR-1-B	1,314.																	
50CR-1-BE	1,564.																	
50C-2		1,130.	1,176.	1,217.	1,246.	1,277.	1,299.	1,329.	1,399.	1,524.	1,923.	2,073.	2,384.	2,463.	2,525.			
50CR-2		555.	596.	634.	664.	691.	716.	742.	805.	929.	1,307.	1,452.	1,748.	1,822.	1,884.			

Approved KnollTextiles Grades/Fabrics

A	Alignment Beacon Bocce Chance Common Ground Commuter Cloth Delite Dristi Hourlgass Mariner Prep Presto Soliloquy Sonnet Stacks Trophy	B	Abacus Argyle Bank Shot Betwixt Bistro Boundary Cameo Chroma Chronicle Close Knit Digit Digital Tape Dovetail Ferry	E continued	Forza Gala II Grande Grandview Journey Keaton Knoll Felt Knoll Hopsack Lyric Night Life Nonchalant CR Paradigm Petal Pusher Pogo Pop Prairie Prim Radiance Ransom Ricochet Roam Rush Hour Soiree Spark Spinoff Nuance Spree Starry Night Summit Sutton Synth Tabloid Venue Versa Vinyl Westwood Wide Angle Zephyr Zipline	C	Atlas Autobahn Axiom Baxter Biota Charm Circa Classic Boucle Dahlia CR Decade Durand Earthwork Echo Empire Stripe Enmesh Entourage Fable CR Fibra Greenwich Hudson Hula Hoop Kora CR Lagos Metro Moto CR Noble Palisade Panache CR Quark	C continued	Roundtrip Sequin CR Sinclair Smart Spectator Spot On Star Struck Stepping Stones Swing Tight Rope Tilden Tower Grid Transition Treble CR Vibe Zari CR	D	Coterie Eclat Weave Hologram In The Loop Island Masquerade Menagerie Origins Satellite Satin Chisel Tara Theory Woodland Zoom	E	Highland Ikat Stripe Ikat Square Kampala Katazome Luberon Mamba Marquee Sherman Shima Whip
----------	--	----------	--	--------------------	--	----------	--	--------------------	--	----------	--	----------	--

Spinneybeck Leather

U	Vicenza Volo	X	Ducale Velour
V	Acqua Andes Embossed Tipped España Velluto Pelle	Y	Capri Cervo Copenhagen Cordovan Distressed Lucca Marissa Prima Riva
W	Alaska Amazon Antique Arizona Derby Forte Lucente Sabrina # Approved for Cal 133 upholstery		

Check with your KnollTextiles or Spinneybeck Representative for changes or additions.

Marcel Breuer

Wassily Chair

	description	seat h	arm h	w	d	h	weight
<i>Designer(s):</i> Marcel Breuer, 1925	50L Wassily chair	16 1/2"	23"	31"	27"	28 3/4"	25 lbs.

Award(s):
The Museum of Modern Art, New York, USA, 1968; Recognition as "Piece of Art," W. Germany, 1982

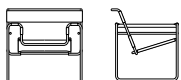

Order Code

<i>Example:</i>	50L-3COLHH
50L	Wassily chair
3COLHH	Haired Hide, Tri-Colored

Note:
The Wassily Chair is part of a collection. Please refer to Cesca side chairs and Laccio tables on pages 86 and 310.

Specify:

1. Pattern number
2. Sling material and color selection

Ordering Information

Spinneybeck Belting Leather:

- ☞ Black (suffix BLBLCK)
- Brown (suffix BL1923)
- Burnt Orange (suffix BL1907)
- Chocolate (suffix BL1902)
- Cognac (suffix BL1904)
- Cream (suffix BL1919)
- Dark Mustard (suffix BL1903)
- Dark Salmon (suffix BL1906)
- Deep Green (suffix BL1911)
- Deep Purple (suffix BL1913)
- Eggplant (suffix BL1926)
- Fudge (suffix BL1901)
- Gun Metal (suffix BL1917)
- Key Lime (suffix BL1910)
- Khaki (suffix BL1922)
- Lemon Meringue (suffix BL1909)
- Light Grey (suffix BL1916)
- Medium Grey (suffix BL1918)
- Putty (suffix BL1920)
- ☞ Simply Red (suffix BL1905)
- Smoke (suffix BL1915)
- Sunshine (suffix BL1908)
- Taupe (suffix BL1921)
- Umber (suffix BL1925)
- Warm Beige (suffix BL1924)
- White (suffix BL1914)

Cowhide leather colors:

- Black (suffix L80)
- Light Brown (suffix L82)
- White Beige (suffix L84)

Haired Hide:

- Black (suffix BLCKHH)
- Black and White (suffix BKWHHH)
- Chestnut (suffix OA12HH)
- Coffee (suffix OA18HH)
- Gold (suffix OCP5HH)
- Mahogany (suffix OA19HH)
- Tan (suffix OCP3HH)
- Tri-Color (suffix 3COLHH)

Upholstery note:

No Customer's Own Materials can be used.

Replacement slings:

Knoll does not recommend replacement slings. This procedure requires the chair to be disassembled and rebuilt, a complex and time consuming process.

☞ KnollStudio 20-Day Program:

The Wassily Chair is available on the KnollStudio 20-Day program in Black and Simply Red Spinneybeck belting leather. For specific information, consult pages 30-33.

pattern no.

50L-() 

\$3,673.

Construction*Cal 133 Fire Code #:*

The Wassily chair complies with California Technical Bulletin 133, see page 18.

Maintenance:

See pages 28-29.

Note:

The KnollStudio logo and signature of Marcel Breuer is stamped into the base of the chair.

The Wassily Chair is Greenguard certified.

Please ask your Spinneybeck Representative for samples of the belting leather and haired hide.

Frame:

Tubular steel with a polished chrome finish

*Upholstery:**Cowhide Slings:*

Thick cowhide leather slings in three colors. Edges dyed to match for Black and Light Brown colors. White Beige will have edges matching Light Brown cowhide color.

Belting Leather:

Highly durable Spinneybeck belting leather in twenty seven colors. Belting leather edges will always match specified color.







Haired Hide:

Spinneybeck haired hide in eight colors. Haired Hide is a natural material, markings are one-of-a-kind and will vary from piece to piece.

Glides:

Four, molded clear plastic glides with twin-pin snap-in construction included with each chair.

Don Chadwick Spark® Series

	description	seat h	w	d	h	textile fabric yds.	weight	arm h
<i>Designer(s):</i> Don Chadwick, 2009	4-C-SD-N Spark stacking side chair 	18"	20 1/2"	22"	31"	0.75	10 lbs.	
<i>Award(s):</i> Editors' Choice Award, Best of NeoCon, June 2009, USA GOOD DESIGN Award, Chicago Athenaeum, 2009, USA	4-C-SD-S Spark stacking side chair, with seat pad 	18"	20 1/2"	22"	31"	0.75	10 lbs.	
	4SDSEAT Seat pad replacement for 4-C-SD-S 							
	4DOLLY Spark stacking dolly 		25"	43"	30 1/4"		19 lbs.	
	4GA Spark ganging mechanism for side chair 							







Order Code

<i>Example:</i>	4-C-SD-S-04-K1000/11
4-C-SD	Spark stacking side chair
S	Seat pad
04	Light Grey
K1000/11	Presto, Navy Blue

Specify:

1. Pattern number
2. Finish selection
3. Cal 133 Fire Code option
4. Textile selection

Finishes:

-  Blue (suffix 02)
-  Citron (suffix 03)
-  Dark Grey (suffix 05)
-  Light Grey (suffix 04)
-  Recycled Black (suffix 06)
-  Red (suffix 01)

Note:

Spark colors Red, Blue and Citron coordinate with KnollStudio Maya Lin Stones in Warm Red, Blue and Chartreuse finishes.

Ordering Information

Maintenance:
See pages 28-29.

Cal 133 Fire Code ♣:
The Spark stacking side and lounge chair complies with the Cal 133 fire code standard if upholstered in Cal 133 approved upholstery. Unupholstered chairs are not Cal 133 approved. Specify suffix -C at end of pattern number and suffix -133 at end of textile selection. Upcharge applies, see page 19.

 **KnollStudio 20-Day Program:**
Spark side and lounge chairs with no upholstery are available on the 20-day program in all finishes. For specific ordering information consult pages 30-30.

Outdoor use:
With proper care and preventative maintenance, the Spark Series is appropriate for outdoor environments.

Note:

The Spark Series is Greenguard certified. The Spark Series is Greenguard Children & Schools certified.

Upholstery/COM information:
Prices shown include fabric upholstery. Contact your Knoll representative for colors. Only approved KnollTextiles may be ordered.

Customer's Own Material is available pending approval. For approval requirements, processing instructions and ordering information please see page 18.

Recycled Content:

The Recycled Black color of both the non-upholstered side chair and the non-upholstered lounge chair contain 40% post-industrial recycled content. Recycled content percentages for the Recycled Black chairs with seat pads will vary depending on the fabric used. All other finishes do not contain recycled content.

Construction

Frame:

Integrally colored, textured, glass reinforced polypropylene; approved for indoor and out door use.

Seat Pad:

Molded highly-resilient polyurethane foam with textile cover and steel fasteners; approved for indoor use only.

Stacking:

Spark side and lounge chairs stack up to 6 units high on the floor and 10 units high on the Spark dolly, which can accommodate the side or lounge chair. The dolly stacked with 10 side chairs measures 54" high and with 10 lounge chairs measures 53" high.

Dolly:





























Tubular metal frame with textured powder coat finish, four handles made of black thermoplastic elastomer (TPE) that act as bumpers to cushion the chairs, and four locking casters. **Not appropriate for outdoor storage.**

pattern no.	unuphol.	grades A	COM B	C	D	E	F	G	H	I
4-C-SD-N 	\$278.									
4-C-SD-S-()	0.	412.	430.	447.	461.	481.	494.	512.	549.	578.
4SDSEAT		178.	197.	214.	228.	248.	261.	278.	315.	346.
4DOLLY	398.									
4GA	7.									

Approved KnollTextiles Grades/Fabrics

Ganging Device:



Semi-translucent TPE. The Spark ganging device adjoins the Spark side chairs' back legs. Position the ganging device so the raised surface in the middle of the device faces toward the front of the chair. The angle of the device should mirror the angle of the chair's back legs.

<p>A</p> <p>Alignment </p> <p>Cat's Cradle </p> <p>Chance</p> <p>Common Ground </p> <p>Commuter Cloth </p> <p>Delite</p> <p>Dristi</p> <p>Hourglass</p> <p>Mariner</p> <p>Prep </p> <p>Presto </p> <p>Sonnet</p> <p>Stacks</p> <p>B</p> <p>Abacus </p> <p>Argyle</p> <p>Bank Shot </p> <p>Belize</p> <p>Betwixt </p> <p>Bistro</p> <p>Boundary </p> <p>Cameo</p> <p>Chronicle</p> <p>Close Knit</p> <p>Digit</p> <p>Dovetail </p> <p>Fast Forward</p> <p>Ferry</p> <p>Gala II</p> <p>Grande</p> <p>Grandview</p> <p>Holbrook</p> <p>Journey</p> <p>Keaton</p> <p>Knoll Felt </p> <p>Knoll Hopsack </p>	<p>B continued</p> <p>Ludlow</p> <p>Lyric</p> <p>Mini Stitch </p> <p>Night Life</p> <p>Paradigm</p> <p>Petal Pusher</p> <p>Pop</p> <p>Prairie</p> <p>Prim</p> <p>Radiance</p> <p>Ransom</p> <p>Ricochet </p> <p>Roam</p> <p>Soiree</p> <p>Rush Hour</p> <p>Spark </p> <p>Spree</p> <p>Starry Night </p> <p>Summit</p> <p>Sutton</p> <p>Tabloid</p> <p>Venue</p> <p>Versa</p> <p>Westwood</p> <p>Zephyr</p> <p>Zipline</p> <p>C</p> <p>Atlas </p> <p>Axiom</p> <p>Baxter</p> <p>Biota </p> <p>Cairo</p> <p>Charm</p> <p>Circa</p> <p>Dahlia CR</p> <p>Decade</p> <p>Durand</p> <p>Earthwork </p> <p>Echo</p>	<p>C continued</p> <p>Enmesh </p> <p>Entourage </p> <p>Fable CR</p> <p>Fibra</p> <p>Greenwich</p> <p>Hudson</p> <p>Hula Hoop</p> <p>Kaleidoscope CR</p> <p>Kora CR</p> <p>Prim</p> <p>Radiance</p> <p>Ransom</p> <p>Ricochet </p> <p>Roam</p> <p>Soiree</p> <p>Rush Hour</p> <p>Spark </p> <p>Spree</p> <p>Starry Night </p> <p>Summit</p> <p>Sutton</p> <p>Tabloid</p> <p>Venue</p> <p>Versa</p> <p>Westwood</p> <p>Zephyr</p> <p>Zipline</p>	<p>C continued</p> <p>Swing</p> <p>Tight Rope</p> <p>Tilden</p> <p>Tower Grid</p> <p>Transition </p> <p>Trable CR</p> <p>Vibe</p> <p>Zari CR</p> <p>D</p> <p>Compass CR</p> <p>Coterie</p> <p>Eclat Weave</p> <p>Hologram</p> <p>Island</p> <p>Masquerade</p> <p>Menagerie</p> <p>Origins</p> <p>Satellite</p> <p>Satin Chisel</p> <p>Tara</p> <p>Theory</p> <p>Woodland</p> <p>Zoom</p> <p>E</p> <p>Highland</p> <p>Ikat Stripe</p> <p>Ikat Square</p> <p>Kampala</p> <p>Katazome</p> <p>Kimono</p> <p>Luberon</p> <p>Mamba</p> <p>Marquee</p> <p>Meroe</p> <p>Sherman</p> <p>Tryst</p> <p>Whip</p>	<p>F</p> <p>Atelier</p> <p>Biscayne</p> <p>Century</p> <p>Coco</p> <p>Cornaro</p> <p>Glider</p> <p>Icon</p> <p>Intrigue</p> <p>Liberty</p> <p>Mod Plaid</p> <p>Rivington</p> <p>Soon</p> <p>Topography</p>	<p>G</p> <p>Djenne</p> <p>Gibson</p> <p>Haze</p> <p>Kinabalu</p> <p>Melange</p> <p>Sablon</p> <p>Serendipity</p> <p>Straie Stripe</p> <p>Ultrasuede </p> <p>H</p> <p>Arno </p> <p>Constance</p> <p>Firefly</p> <p>Gezelle</p> <p>Magritte</p> <p>Rosemond</p> <p>I</p> <p>Aswan</p> <p>Diamond Days</p> <p>Digi Velvet</p> <p>Dynamic</p> <p>Ita</p> <p>Olema</p> <p>Piper</p> <p>Rutledge</p> <p>Vermeer</p> <p>Zimba</p>
---	--	--	---	---	---

 Approved for Cal 133 upholstery.

Check with your KnollTextiles or Spinneybeck Representative for changes or additions.

Don Chadwick Spark® Series

	description	seat h	w	d	h	textile fabric yds.	weight	arm h
<i>Designer(s):</i> Don Chadwick, 2009	4-C-LG-N Spark stacking lounge chair	17"	25 1/2"	25 1/2"	30 1/2"	0.80	14 lbs.	
<i>Award(s):</i> Editors' Choice Award, Best of NeoCon, June 2009, USA GOOD DESIGN Award, Chicago Athenaeum, 2009, USA								
	4-C-LG-S Spark stacking lounge chair, with seat pad	17"	25 1/2"	25 1/2"	30 1/2"	0.80	14 lbs.	
								
	4LGSEAT Seat pad replacement for 4-C-LG-S							









Order Code

<i>Example:</i>	4-C-SD-S-04-K1000/11
4-C-SD	Spark stacking side chair
S	Seat pad
04	Light Grey
K1000/11	Presto, Navy Blue

Specify:

1. Pattern number
2. Finish selection
3. Cal 133 Fire Code option
4. Textile selection

Finishes:

-  Blue (suffix 02)
-  Citron (suffix 03)
-  Dark Grey (suffix 05)
-  Light Grey (suffix 04)
-  Recycled Black (suffix 06)
-  Red (suffix 01)

Note:

Spark colors Red, Blue and Citron coordinate with KnollStudio Maya Lin Stones in Warm Red, Blue and Chartreuse finishes.

Ordering Information

Maintenance:
See pages 28-29.

Cal 133 Fire Code #:
The Spark stacking side and lounge chair complies with the Cal 133 fire code standard if upholstered in Cal 133 approved upholstery. Unupholstered chairs are not Cal 133 approved. Specify suffix -C at end of pattern number and suffix -133 at end of textile selection. Upcharge applies, see page 19.

 *KnollStudio 20-Day Program:*
Spark side and lounge chairs with no upholstery are available on the 20-day program in all finishes. For specific ordering information consult pages 30-30.

Outdoor use:
With proper care and preventative maintenance, the Spark Series is appropriate for outdoor environments.

Note:

The Spark Series is Greenguard certified. The Spark Series is Greenguard Children & Schools certified.

Upholstery/COM information:

Prices shown include fabric upholstery. Contact your Knoll representative for colors. Only approved KnollTextiles may be ordered.

Customer's Own Material is available pending approval. For approval requirements, processing instructions and ordering information please see page 18.

Recycled Content:

The Recycled Black color of both the non-upholstered side chair and the non-upholstered lounge chair contain 40% post-industrial recycled content. Recycled content percentages for the Recycled Black chairs with seat pads will vary depending on the fabric used. All other finishes do not contain recycled content.

Construction

Frame:

Integrally colored, textured, glass reinforced polypropylene; approved for indoor and out door use.

Seat Pad:

Molded highly-resilient polyurethane foam with textile cover and steel fasteners; approved for indoor use only.

Stacking:

Spark side and lounge chairs stack up to 6 units high on the floor and 10 units high on the Spark dolly, which can accommodate the side or lounge chair. The dolly stacked with 10 side chairs measures 54" high and with 10 lounge chairs measures 53" high.

Dolly:





























Tubular metal frame with textured powder coat finish, four handles made of black thermoplastic elastomer (TPE) that act as bumpers to cushion the chairs, and four locking casters. **Not appropriate for outdoor storage.**

pattern no.	unuphol.	grades A	COM B	C	D	E	F	G	H	I
4-C-LG-N 	\$432.									
4-C-LG-S-()		564.	582.	600.	614.	634.	647.	665.	702.	732.
4LGSEAT		190.	208.	225.	240.	259.	273.	290.	328.	356.

Approved KnollTextiles Grades/Fabrics

Ganging Device:

Semi-translucent TPE. The Spark ganging device adjoins the Spark side chairs' back legs. Position the ganging device so the raised surface in the middle of the device faces toward the front of the chair. The angle of the device should mirror the angle of the chair's back legs.





<p>A</p> <p>Alignment </p> <p>Cat's Cradle </p> <p>Chance</p> <p>Common Ground </p> <p>Commuter Cloth </p> <p>Delite</p> <p>Dristi</p> <p>Hourglass</p> <p>Mariner</p> <p>Prep </p> <p>Presto </p> <p>Sonnet</p> <p>Stacks</p> <p>B</p> <p>Abacus </p> <p>Argyle</p> <p>Bank Shot </p> <p>Belize</p> <p>Betwixt </p> <p>Bistro</p> <p>Boundary </p> <p>Cameo</p> <p>Chronicle</p> <p>Close Knit</p> <p>Digit</p> <p>Dovetail </p> <p>Fast Forward</p> <p>Ferry</p> <p>Gala II</p> <p>Grande</p> <p>Grandview</p> <p>Holbrook</p> <p>Journey</p> <p>Keaton</p> <p>Knoll Felt </p> <p>Knoll Hopsack </p>	<p>B continued</p> <p>Ludlow</p> <p>Lyric</p> <p>Mini Stitch </p> <p>Night Life</p> <p>Paradigm</p> <p>Petal Pusher</p> <p>Pop</p> <p>Prairie</p> <p>Prim</p> <p>Radiance</p> <p>Ransom</p> <p>Ricochet </p> <p>Roam</p> <p>Soiree</p> <p>Rush Hour</p> <p>Spark </p> <p>Spree</p> <p>Starry Night </p> <p>Summit</p> <p>Sutton</p> <p>Tabloid</p> <p>Venue</p> <p>Versa</p> <p>Westwood</p> <p>Zephyr</p> <p>Zipline</p> <p>C</p> <p>Atlas </p> <p>Axiom</p> <p>Baxter</p> <p>Biota </p> <p>Cairo</p> <p>Charm</p> <p>Circa</p> <p>Dahlia CR</p> <p>Decade</p> <p>Durand</p> <p>Earthwork </p> <p>Echo</p>	<p>C continued</p> <p>Enmesh </p> <p>Entourage </p> <p>Fable CR</p> <p>Fibra</p> <p>Greenwich</p> <p>Hudson</p> <p>Hula Hoop</p> <p>Kaleidoscope CR</p> <p>Kora CR</p> <p>Lagos</p> <p>Legend CR</p> <p>Lore CR</p> <p>Milestone</p> <p>Metro</p> <p>Noble</p> <p>Palisade</p> <p>Panache CR</p> <p>Quark </p> <p>Roundtrip </p> <p>Sandpiper</p> <p>Sequin CR</p> <p>Sinclair</p> <p>Smart</p> <p>Spectator </p> <p>Spot On</p> <p>Star Struck</p> <p>Stepping Stones</p>	<p>C continued</p> <p>Swing</p> <p>Tight Rope</p> <p>Tilden</p> <p>Tower Grid</p> <p>Transition </p> <p>Trable CR</p> <p>Vibe</p> <p>Zari CR</p> <p>D</p> <p>Compass CR</p> <p>Coterie</p> <p>Eclat Weave</p> <p>Hologram</p> <p>Island</p> <p>Masquerade</p> <p>Menagerie</p> <p>Origins</p> <p>Satellite</p> <p>Satin Chisel</p> <p>Tara</p> <p>Theory</p> <p>Woodland</p> <p>Zoom</p> <p>E</p> <p>Highland</p> <p>Ikat Stripe</p> <p>Ikat Square</p> <p>Kampala</p> <p>Katazome</p> <p>Kimono</p> <p>Luberon</p> <p>Mamba</p> <p>Marquee</p> <p>Meroe</p> <p>Sherman</p> <p>Tryst</p> <p>Whip</p>	<p>F</p> <p>Atelier</p> <p>Biscayne</p> <p>Century</p> <p>Coco</p> <p>Cornaro</p> <p>Glider</p> <p>Icon</p> <p>Intrigue</p> <p>Liberty</p> <p>Mod Plaid</p> <p>Rivington</p> <p>Soon</p> <p>Topography</p>	<p>G</p> <p>Djenne</p> <p>Gibson</p> <p>Haze</p> <p>Kinabalu</p> <p>Melange</p> <p>Sablon</p> <p>Serendipity</p> <p>Straie Stripe</p> <p>Ultrasuede </p> <p>H</p> <p>Arno </p> <p>Constance</p> <p>Firefly</p> <p>Gezelle</p> <p>Magritte</p> <p>Rosemond</p> <p>I</p> <p>Aswan</p> <p>Diamond Days</p> <p>Digi Velvet</p> <p>Dynamic</p> <p>Ita</p> <p>Olema</p> <p>Piper</p> <p>Rutledge</p> <p>Vermeer</p> <p>Zimba</p>
---	--	--	---	---	---

 Approved for Cal 133 upholstery.

Check with your KnollTextiles or Spinneybeck Representative for changes or additions.

Pepe Cortés

Jamaica Barstool

	description	seat h	w	d	h	type	weight
<i>Designer(s):</i> Pepe Cortés, 1993 	30C Jamaica Barstool, bar height 	30"	20"	20"	32"	aluminum seat	11 lbs.
	30C2 Jamaica Barstool, counter height 	26"	17 1/2"	17 1/2"	28 1/4"	aluminum seat	11 lbs.
	30C3 Jamaica Barstool, low, on casters 		19"	19"	17 1/4"		10 lbs.

Order Code

<i>Example:</i>	30C-A
30C	Jamaica barstool, bar height
A	Aluminum

Specify:

1. Pattern number
2. Finish selection

Ordering Information

Finishes:
Aluminum (suffix A)

Note:
Available in the United States only.

 *KnollStudio 20-Day Program:*
The Jamaica bar and counter height stools in aluminum finish are available on the 20-day program. For specific information, consult pages 30-33.

Outdoor use:
The Jamaica Stool is approved for indoor use only.

Cal 133 Fire Code #:
The Jamaica Stool in aluminum finish comply with California Technical Bulletin 133. See page 18.

Maintenance:
See pages 28-29.

Note:
The Jamaica Barstool is Greenguard certified.

pattern no.

30C-A 

\$1,343.

30C2-A 

1,343.

30C3-A

1,307.



Construction

Seat and Frame

Contoured seat swivels 360°.
Constructed of anodized aluminum.
Base is chrome plated steel with plastic
glides.
The Jamaica aluminum stools on glides
are 100% recyclable.

Jamaica Barstool is manufactured in
Spain by Amat-3.

Jonathan Crinion Crinion Chair

	description	seat h	arm h	w	d	h	textile fabric yds.	req. leather sq. ft.	weight	finish
<i>Designer(s):</i> Jonathan Crinion, 1999	58A Arm chair, upholstered seat 	17 1/2"	26 1/2"	23 1/4"	19 1/2"	30 3/4"	0.7	13	18 lbs.	beech stains
		17 1/2"	26 1/2"	23 1/4"	19 1/2"	30 3/4"	0.7	13	17 lbs.	maple
<i>Award(s):</i> FX International Interior Design Award, 1999	58C Armless chair, upholstered seat 	17 1/2"		20 1/2"	19 1/2"	30 3/4"	0.7	13	16 lbs.	beech stains
		17 1/2"		20 1/2"	19 1/2"	30 3/4"	0.7	13	15 lbs.	maple
	58A-R Seat pad replacement, for arm chair with upholstered seat 58A						0.7	13		
	58C-R Seat pad replacement, for armless chair with upholstered seat 58C						0.7	13		

Order Code

<i>Example:</i>	58A-BB-K715/3
58A	Crinion arm chair
B323	Medium Walnut
K715/3	Abacus, Gold Coin

Specify:

1. Pattern number
2. Finish selection
3. Textile selection

Ordering Information

Clear Maple finish:
European Maple (suffix EKC)

Beech frame stains:
Beech (suffix B311)
Bronzed Cherry (suffix B312A)
Burnt Walnut (suffix B313)
Deep Red Mahogany (suffix B328)
Ebonized (suffix BE)
Light Cherry (suffix B315)
Medium Cherry (suffix B319)
Medium Red Mahogany (suffix BR)
Medium Walnut (suffix B323)
Natural Beech (suffix BN)
Warm Brown Walnut (suffix J)

Upholstery/COM information:
Prices shown include fabric or leather upholstery. Contact your Knoll representative for colors. Only approved KnollTextiles and Spinneybeck leathers may be ordered.

Customer's Own Material is available pending approval. For approval requirements, processing instructions and ordering information please see page 18.

KnollStudio wood finishes:

KnollStudio wood finishes complement a large variety of KnollStudio veneer and Knoll Office veneer finishes. To select correct complementary finish, please refer to KnollStudio Wood Finish Matrix on page 25. Complementary finishes are available at no upcharge. If no complementary standard finish is available, please refer to custom finish policy below.

Custom finishes:

To complement non-Knoll wood veneer or lumber finishes, a one-time, non-negotiable net upcharge of \$618 applies. Re-orders are at no upcharge.

Please contact your KnollStudio representative, dealer or Customer Service associate for complete custom finish information and Order Code. Minimum order quantity for any custom finish order: 4 chairs.

Cal 133 Fire Code:

Crinion Chairs with upholstered seat comply with the California Technical Bulletin 133 standard if upholstered in Cal 133 approved upholstery. Specify suffix -C at end of pattern number and suffix -133 at end of textile selection. Upcharge applies, see page 18.

Maintenance:

See pages 28-29.

Note:

The Crinion Chair is Greenguard certified.

Construction

Frame:

Clear Maple Chair: Select clear European maple hardwood frame with maple plywood back panel in clear finish. Dowel, mortise and tenon construction. Arm supported by metal cross dowel.

Maple option on the Crinion chair is manufactured in Europe using European maple. European Maple (EKC) has more white/yellow tones than the North American Maple which tends to be more pink.

Beech Chair: Select beech hardwood frame with plywood back panel in clear or stained finishes. Arm supported by metal cross dowel.

Seat pad:

Upholstered, high-density polyurethane foam seat pad on a plywood seat basket with Dymetrol® suspension. Seat pad reaches to the seat frame edge, surrounds arm.

Seat pad replacement:

Seat pad can be replaced in the field.

Finish:

Catalyzed lacquer protective coating. Hand-applied final wax coating.

High Traffic Areas:

When specifying armless chair in high use or high traffic areas, we recommend the use of a stretcher for added strength. Contact CPD or your KnollStudio sales representative for more information.

pattern no.	grades A	COM B	C	D	E	F	G	H	I	COL U	V	W	X	Y
58A-()	\$1,593.	\$1,624.	\$1,652.	\$1,684.	\$1,709.	\$1,728.	\$1,763.	\$1,819.	\$1,868.	\$2,021.	\$2,133.	\$2,362.	\$2,407.	\$2,463.
58A-(EKC)	1,952.	1,982.	2,010.	2,042.	2,067.	2,087.	2,121.	2,177.	2,227.	2,380.	2,492.	2,720.	2,766.	2,820.
58C-()	1,357.	1,388.	1,417.	1,446.	1,478.	1,492.	1,522.	1,587.	1,630.	1,785.	1,896.	2,123.	2,172.	2,224.
58C-(EKC)	1,616.	1,646.	1,675.	1,704.	1,735.	1,749.	1,780.	1,843.	1,888.	2,042.	2,153.	2,380.	2,430.	2,479.
58A-R-()	266.	297.	320.	351.	377.	390.	423.	481.	523.	667.	774.	989.	1,035.	1,086.
58C-R-()	266.	297.	320.	351.	377.	390.	423.	481.	523.	667.	774.	989.	1,035.	1,086.

Approved KnollTextiles Grades/Fabrics

A	E continued	C	C continued
Alignment ‡	Forza	Atlas	Stepping Stones
Analogy	Gala II	Autobahn	Spectator
Beacon	Grande	Axiom	Spot On
Bocce	Grandview	Baxter	Swing
Chance	Holbrook	Biota ‡	Tight Rope
Common Ground ‡	Journey	Charm	Tilden
Commuter Cloth ‡	Keaton	Circa	Tower Grid
Cotton Duck	Knoll Felt	Classic Boucle	Transition ‡
Delite	Knoll Hopsack	Dahlia CR	Treble CR
Dristi	Ludlow	Decade	Vibe
Foil Rap	Lytic	Durand	Zari CR
Heavy Metal	Mini Stitch ‡	Earthwork ‡	
Hourglass	Night Life	Echo	D
Mariner	Nonchalant CR	Empire Stripe	Compass CR
Metaphor	Paradigm	Enmesh ‡	Coterie
Monarch ‡	Petal Pusher	Entourage	Hologram
Noble	Pop	Fable CR	In The Loop
Prep ‡	Prairie	Greenwich	Masquerade
Presto ‡	Prim ‡	Hudson	Menagerie
Sinclair	Radiance	Hula Hoop	Origins
Soliloquy	Ransom	Kaleidoscope CR	Satellite
Sonnet	Ricochet ‡	Kora CR	Satin Chisel
Stacks	Roam	Lagos	Tara
Trophy	Rush Hour	Legend CR	Theory
	Soiree	Lore CR	Zoom
	Spark ‡	Magnolia	
B	Spinoff Nuance	Metro	E
Abacus ‡	Spree	Milestone	Highland
Argyle	Starry Night ‡	Moto CR	Ikot Stripe
Backdrop	Sutton	Palisade	Ikot Square
Bank Shot	Synth	Panache CR	Kampala
Belize	Tabloid	Posh	Katazome
Betwixt ‡	Utmost	Quark	Luberon
Bistro ‡	Venue	Regard CR	Mamba
Boundary ‡	Versa	Roundtrip	Marquee
Cameo	Vinyl	Sandpiper	Sherman
Chroma ‡	Westwood	Sequin CR	Shima
Chronicle	Wide Angle ‡	Smart	Tryst
Close Knit	Zephyr	Star Struck	Whip ‡
Digit	Zipline		
Digital Tape			
Dovetail ‡			
Fast Forward			
Ferry			

Spinneybeck Leather

U	V	Y
Vicenza ‡	Acqua ‡	Capri ‡
Volo ‡	Andes ‡	Cervo
	Embossed Tipped	Copenhagen ‡
	España ‡	Cordovan ‡
	Hand Tipped	Distressed
	Velluto Pelle ‡	Lucca
		Marissa ‡
W		Portofino
Alaska ‡		Prima ‡
Amazon ‡		Riva ‡
Antique ‡		Torello
Arizona ‡		
Forte ‡		
Lucente		
Sabrina ‡		
	X	
	Ducale ‡	
	Ducale Velour ‡	

‡ Available for Cal 133 upholstery.

Check with your KnollTextiles or Spinneybeck Representative for changes or additions.

Joseph Paul D'Urso

Contract Lounge Seating

Designer(s):
Joseph Paul D'Urso, 2008



description	w	d	h	seat h	arm h	type	textile fabric yds.	leather sq ft	weight
2160 Contract Lounge chair, same upholstery, frame and cushions	34"	36 1/2"	30 1/2"	17 3/8"	22 3/8"		7.6	105	70 lbs.
2160 Contract Lounge chair, combination upholstery, frame and cushions	34"	36 1/2"	30 1/2"	17 3/8"		frame uph.	4.6	60	
						upchg, cushions	3.2	50	

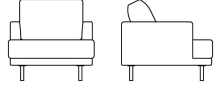

Order Code

<i>Example:</i>	2160-C-H800/40
2160	D'Urso Contract Lounge Collection, lounge chair
C	Polished Chrome legs
H800/40	Cato, Orange
<i>Example:</i>	2161-C-S-HT1502-K1206/6
2161	D'Urso Contract Lounge Collection, small sofa
C	Polished Chrome legs
S	Split upholstery
HT1502	Surround in Hand Tipped, Mesa Verde
K1206/6	Cushions in Knoll Hopsack, Gold

Specify:

1. Pattern number
2. Leg finish
3. Textile selection

Specify with split upholstery:

1. Pattern number
2. Leg finish
3. Split upholstery option
4. Textile selection, Surround
5. Textile selection, Cushions

Ordering Information

Leg finishes:
Polished Chrome (suffix C)

Upholstery/COM information:
Prices shown includes fabric or leather upholstery. Contact your Knoll representative for colors. Only approved KnollTextles and Spinneybeck leathers may be ordered.

Customer's Own Material is available pending approval. For approval requirements, processing instructions and ordering information please see page 13.

Maintenance:
See pages 28-29.

Construction

Frame:
Constructed of plywood with sinuous spring seat suspension and matrix back suspension. Standard lounge chair and small sofa depth is 36"; residential sofa is 40" deep.

Upholstery:
One seat and back cushion for the Lounge Chair, two seat and back cushions for the Small Sofa, one semi-attached cushion for Ottoman. For units with combination upholstery, add list price of surround in appropriate grade with the list price of cushions to obtain total list price for item.

Railroad upholstery application is standard for all non-directional textiles. Please see 'Stitching' for seam details.

Cushions:
Seat cushions constructed of highly resilient polyurethane foam and polyester fiber, wrapped in polyester fiber batting. Back cushion constructed with a soft polyurethane foam core and polyester fiber fill. Side cushion constructed of 10/90 down with a down proof ticking. Leather cushions feature a perforated zipper breather panel.

Stitching:
Non-directional textiles with railroad application, single needle topstitch for arms, double needle topstitch for seat and back cushions; directional textiles, single needle topstitch for arms, double needle topstitch for seat and back cushions, single blind stitch for vertical seams of seat cushion, a vertical single blind center seam joins inside and outside back panels of the sofa; leather, single needle topstitch for arms, double needle topstitch for seat and back cushions, single blind stitch for vertical seams of seat cushion, a vertical double needle topstitch seam joins inside and outside back panels of sofa. Ottoman; all applications, double needle topstitch for horizontal cushion seams, single blind seam for vertical seams of seat cushion.

Legs:
6" steel leg, 1 1/4" diameter, available in polished chrome with black nylon glides.

pattern no.	grades													
	A	B	C	D	E	F	G	H	I	U	V	W	X	Y
2160-C(-)	\$4,080.	\$4,263.	\$4,434.	\$4,625.	\$4,779.	\$4,891.	\$5,082.	\$5,445.	\$5,713.	\$6,912.	\$7,413.	\$8,424.	\$8,637.	\$8,882.
2160S-C-(-)(-)	3,113.	3,252.	3,384.	3,529.	3,646.	3,734.	3,878.	4,156.	4,358.	4,960.	5,335.	6,098.	6,256.	6,442.
upchg, cushions	1,334.	1,394.	1,450.	1,513.	1,563.	1,600.	1,661.	1,781.	1,868.	2,126.	2,287.	2,614.	2,681.	2,760.

Approved KnollTextiles Grades/Fabrics

A	Alignment ‡ Beacon Bocce Cat's Cradle Common Ground Commuter Cloth ‡ Delite Dristi Hourglass Mariner Monarch ‡ Prep ‡ Presto ‡ Sonnet Stacks Trophy	B	continued Mini Stitch ‡ Night Life Nonchalant CR Paradigm Pogo Pop Prairie Prim Radiance Ransom Ricochet ‡ Rush Hour Spark ‡ Spree Starry Night ‡ Summit Sutton Synth Tabloid Venue Versa Vinyl Westwood Wide Angle ‡ Zephyr Zipline	C	continued Echo Empire Stripe Emmesh ‡ Entourage Fable CR Fibra Hudson Hula Hoop Kaleidoscope CR Kora CR Lagos Legend CR Lore CR Metro Milestone Moto CR Palisade Panache CR Quark Regard CR Roundtrip Sahara Sandpiper Sequin CR Spectator * Spot On Star Struck Stepping Stones Swing Tilden Transition ‡ Vibe Zari CR	D	Compass CR Coterie Eclat Weave Hologram Island Masquerade Menagerie Satelite Satin Chisel Tara Theory Woodland Zoom	E	Highland Ikat Stripe Ikat Square Kampala Katazome Kimono Luberon Mamba Marquee Meroe Sherman Shima Tryst Whip
----------	--	----------	--	----------	--	----------	---	----------	--

Spinneybeck Leather

F	Atelier Calais Cotton Velvet Coco Cornaro Eclipse Icon Intrigue Liberty Mod Plaid Rivington Soon Topography Totem Tweed Frieze	H	Arno ‡ Constance Firefly Gezelle Magritte Rosemond	I	Byron Cato Diamond Days Digi Velvet Dynamic Gates Knoll Velvet Piper Ravello Tudor Vermeer Walker Worth Zimba	U	Vicenza ‡ Volo ‡	V	Acqua ‡ Andes ‡ Embossed Tipped España ‡ Hand Tipped ‡ Velluto Pelle ‡	W	Alaska ‡ Amazon ‡ Antique ‡ Arizona Derby ‡ Forte ‡ Lucente Sabrina ‡	X	Ducale Ducale Velour ‡	Y	Capri ‡ Cervo Copenhagen ‡ Cordovan ‡ Distressed ‡ Marissa ‡ Prima ‡ Riva ‡ Saddle ‡
----------	--	----------	---	----------	--	----------	---------------------	----------	---	----------	--	----------	---------------------------	----------	--

* Approved for 2161P only.

Check with your KnollTextiles or Spinneybeck Representative for additions or changes.

Joseph Paul D'Urso

Contract Lounge Seating

Designer(s):
Joseph Paul D'Urso, 2008



description	width	depth	height	seat h, max	arm h, max	type	textile fabric yards	leather sq ft	weight
2161 Contract Small Sofa, same upholstery, frame and cushions	74"	36 1/2"	30 1/2"	17 3/8"	22 1/8"		13.5	215	135 lbs.
2161 Contract Small Sofa, combination upholstery, frame and cushions	74"	36 1/2"	30 1/2"	17 3/8"		frame uph.	6.5	95	
						upchg, cushions	7	120	
2163 Contract Ottoman, same upholstery, frame and cushions	28 1/2"	28 1/2"	16"	16"			3.5	45	29 lbs.
2163 Contract Ottoman, combination upholstery, frame and cushions	28 1/2"	28 1/2"	16"	16"		frame uph.	1.4	15	
						upchg, cushions	2.8	30	
2161P Optional side cushion for small sofa	17"	3"	11"				1	n/a	5 lbs.

Order Code

<i>Example:</i>	2160-C-H800/40
2160	D'Urso Contract Lounge Collection, lounge chair
C	Polished Chrome legs
H800/40	Cato, Orange
<i>Example:</i>	2161-C-S-HT1502-K1206/6
2161	D'Urso Contract Lounge Collection, small sofa
C	Polished Chrome legs
S	Split upholstery
HT1502	Surround in Hand Tipped, Mesa Verde
K1206/6	Cushions in Knoll Hopsack, Gold

Specify:

1. Pattern number
2. Leg finish
3. Textile selection

Specify with split upholstery:

1. Pattern number
2. Leg finish
3. Split upholstery option
4. Textile selection, Surround
5. Textile selection, Cushions

Ordering Information

Leg finishes:
Polished Chrome (suffix C)

Upholstery/COM information:
Prices shown includes fabric or leather upholstery. Contact your Knoll representative for colors. Only approved KnollTextles and Spinneybeck leathers may be ordered.

Customer's Own Material is available pending approval. For approval requirements, processing instructions and ordering information please see page 13.

Maintenance:
See pages 28-29.

Construction

Frame:
Constructed of plywood with sinuous spring seat suspension and matrix back suspension. Standard lounge chair and small sofa depth is 36"; residential sofa is 40" deep.

Upholstery:
One seat and back cushion for the Lounge Chair, two seat and back cushions for the Small Sofa, one semi-attached cushion for Ottoman. For units with combination upholstery, add list price of surround in appropriate grade with the list price of cushions to obtain total list price for item.

Railroad upholstery application is standard for all non-directional textiles. Please see 'Stitching' for seam details.

Cushions:
Seat cushions constructed of highly resilient polyurethane foam and polyester fiber, wrapped in polyester fiber batting. Back cushion constructed with a soft polyurethane foam core and polyester fiber fill. Side cushion constructed of 10/90 down with a down proof ticking. Leather cushions feature a perforated zipper breather panel.

Stitching:
Non-directional textiles with railroad application, single needle topstitch for arms, double needle topstitch for seat and back cushions; directional textiles, single needle topstitch for arms, double needle topstitch for seat and back cushions, single blind stitch for vertical seams of seat cushion, a vertical single blind center seam joins inside and outside back panels of the sofa; leather, single needle topstitch for arms, double needle topstitch for seat and back cushions, single blind stitch for vertical seams of seat cushion, a vertical double needle topstitch seam joins inside and outside back panels of sofa. Ottoman; all applications, double needle topstitch for horizontal cushion seams, single blind seam for vertical seams of seat cushion.

Legs:
6" steel leg, 1 1/4" diameter, available in polished chrome with black nylon glides.

pattern no.	grade A	COM B	C	D	E	F	G	H	I	COL U	V	W	X	Y
2161-C(-)	\$6,440.	\$6,762.	\$7,069.	\$7,407.	\$7,683.	\$7,883.	\$8,219.	\$8,864.	\$9,340.	\$12,174.	\$13,195.	\$15,273.	\$15,705.	\$16,209.
2161S-C-(-)(-)	4,914.	5,159.	5,394.	5,651.	5,863.	6,014.	6,271.	6,763.	7,125.	8,736.	9,468.	10,958.	11,269.	11,630.
upchg, cushions	2,106.	2,211.	2,311.	2,422.	2,512.	2,577.	2,687.	2,898.	3,054.	3,744.	4,058.	4,697.	4,831.	4,985.
2163-C(-)	2,457.	2,557.	2,652.	2,757.	2,843.	2,906.	3,010.	3,211.	3,360.	3,815.	4,028.	4,463.	4,554.	4,660.
2163S-C-(-)(-)	1,874.	1,952.	2,023.	2,103.	2,169.	2,218.	2,297.	2,450.	2,563.	2,737.	2,891.	3,203.	3,266.	3,343.
upchg, cushions	803.	836.	867.	902.	930.	950.	985.	1,051.	1,098.	1,173.	1,239.	1,373.	1,401.	1,434.
2161P(-)	453.	478.	500.	525.	545.	560.	585.	633.	668.					

Approved KnollTextiles Grades/Fabrics

A Alignment ‡ Beacon Bocce Cat's Cradle Common Ground Commuter Cloth ‡ Delite Dristi Hourglass Mariner Monarch ‡ Prep ‡ Presto ‡ Sonnet Stacks Trophy	B continued Mini Stitch ‡ Night Life Nonchalant CR Paradigm Pogo Pop Prairie Prim Radiance Ransom Ricochet ‡ Rush Hour Spark ‡ Spree Starry Night ‡ Summit Sutton Synth Tabloid Venue Versa Vinyl Westwood Wide Angle ‡ Zephyr Zipline	C continued Echo Empire Stripe Enmesh ‡ Entourage Fable CR Fibra Hudson Hula Hoop Kaleidoscope CR Kora CR Lagos Legend CR Lore CR Metro Milestone Moto CR Palisade Panache CR Quark Regard CR Roundtrip Sahara Sandpiper Sequin CR Spectator * Spot On Star Struck Stepping Stones Swing Tilden Transition ‡ Vibe Zari CR	D Compass CR Coterie Eclat Weave Hologram Island Masquerade Menagerie Satelite Satin Chisel Tara Theory Woodland Zoom	E Highland Ikat Stripe Ikat Square Kampala Katazome Kimono Luberon Mamba Marquee Meroe Sherman Shima Tryst Whip
--	---	---	---	--

Spinneybeck Leather



U Vicenza ‡ Volo ‡	V Acqua ‡ Andes ‡ Embossed Tipped España ‡ Hand Tipped ‡ Velluto Pelle ‡	W Alaska ‡ Amazon ‡ Antique ‡ Arizona Derby ‡ Forte ‡ Lucente Sabrina ‡	X Ducale Ducale Velour ‡	Y Capri ‡ Cervo Copenhagen ‡ Cordovan ‡ Distressed ‡ Marissa ‡ Prima ‡ Riva ‡ Saddle ‡
---------------------------------	---	--	---------------------------------------	--

* Approved for 2161P only.

Check with your KnollTextiles or Spinneybeck Representative for additions or changes.

Joseph Paul D'Urso

Residential Lounge Seating

	description	w	d	h	seat h	arm h	type	textile fabric yds.	leather sq ft.	weight
<i>Designer(s):</i> Joseph Paul D'Urso, 2008	2160R Residential Lounge chair, same upholstery, frame and cushions	34"	36 1/2"	28 1/2"	15 3/8"	20 7/8"		7.6	105	67 lbs.
	 									
	2160R Residential Lounge chair, combination upholstery, frame and cushions	34"	36 1/2"	28 1/2"	15 3/8"		frame uph.	4.6	60	
							upchg, cushions	3.2	50	

Order Code

<i>Example:</i>	2160R-OE-K162/25
2160R	D'Urso Residential Lounge Collection, lounge chair
OE	Ebonized legs
K162/25	Classic Boucle, Aegean
<i>Example:</i>	21623R-0313-S-K1152/8-K1024/3
2163R	D'Urso Residential Lounge Collection, ottoman
0313	Burnt Walnut legs
S	Split upholstery
K1152/8	Surround in Stirling, Cobble
K1024/3	Cushions in Coco, Ciel

Specify:

1. Pattern number
2. Leg finish
3. Textile selection

Specify with split upholstery:

1. Pattern number
2. Leg finish
3. Split upholstery option
4. Textile selection, Surround
5. Textile selection, Cushions

Ordering Information

Leg finishes:
Burnt Walnut on Oak (suffix 0313)
Clear Oak (suffix OC)
Ebonized on Oak (suffix OE)
Polished Chrome (suffix C)

Upholstery/COM information:
Prices shown includes fabric or leather upholstery. Contact your Knoll representative for colors. Only approved KnollTexiles and Spinneybeck leathers may be ordered.

Customer's Own Material is available pending approval. For approval requirements, processing instructions and ordering information please see page 18.

Maintenance:
See pages 28-29.

Construction

Frame:
Constructed of plywood with sinuous spring seat suspension and matrix back suspension. Standard lounge chair and sofa depth is 36"; residential sofa is 40" deep.

Upholstery:
One seat and back cushion for the Lounge Chair, two seat and back cushions for the Sofa, one semi-attached cushion for Ottoman. For units with combination upholstery, add list price of surround in appropriate grade with the list price of cushions to obtain total list price for item.

Railroad upholstery application is standard for all non-directional textiles. Please see 'Stitching' for seam details.

Cushions:
Seat cushions constructed of highly resilient polyurethane foam and polyester fiber, wrapped in polyester fiber batting. Back cushion constructed with a soft polyurethane foam core and polyester fiber fill. Side cushion constructed of 10/90 down with a down proof ticking.

Leather cushions feature a perforated zipper breather panel.

Stitching:
Non-directional textiles with railroad application, single needle topstitch for arms, double needle topstitch for seat and back cushions; directional textiles, single needle topstitch for arms, double needle topstitch for seat and back cushions, single blind stitch for vertical seams of seat cushion, a vertical single blind center seam joins inside and outside back panels of the sofa; leather, single needle topstitch for arms, double needle topstitch for seat and back cushions, single blind stitch for vertical seams of seat cushion, a vertical double needle topstitch seam joins inside and outside back panels of sofa. Ottoman; all applications, double needle topstitch for horizontal cushion seams, single blind seam for vertical seams of seat cushion.

Legs:
4" steel leg, 1 1/4" diameter, available in polished chrome with black nylon glides, or 4" turned solid oak leg available in natural oak, medium walnut on oak and ebonized oak with white nylon glides.

pattern no.	grades													
	A	B	C	D	E	F	G	H	I	U	V	W	X	Y
2160R-(-)(-)	\$4,080.	\$4,263.	\$4,434.	\$4,625.	\$4,779.	\$4,891.	\$5,082.	\$5,445.	\$5,713.	\$6,912.	\$7,413.	\$8,424.	\$8,637.	\$8,882.
2160RS-(-)(-)(-)	3,113.	3,252.	3,384.	3,529.	3,646.	3,734.	3,878.	4,156.	4,358.	4,960.	5,335.	6,098.	6,256.	6,442.
upchg, cushions	1,334.	1,394.	1,450.	1,513.	1,563.	1,600.	1,661.	1,781.	1,868.	2,126.	2,287.	2,614.	2,681.	2,760.

Approved KnollTextiles Grades/Fabrics

A	Alignment † Beacon Bocce Cat's Cradle Common Ground Commuter Cloth † Delite Dristi Hourglass Mariner Monarch † Prep † Presto † Sonnet Stacks Trophy	B	continued Mini Stitch † Night Life Nonchalant CR Paradigm Pogo Pop Prairie Prim Radiance Ransom Ricochet † Rush Hour Spark † Spree Starry Night † Summit Sutton Synth Tabloid Venue Versa Vinyl Westwood Wide Angle † Zephyr Zipline	C	continued Echo Empire Stripe Emmesh † Entourage Fable CR Fibra Hudson Hula Hoop Kaleidoscope CR Kora CR Lagos Legend CR Lore CR Metro Milestone Moto CR Palisade Panache CR Quark Regard CR Roundtrip Sahara Sandpiper Sequin CR Spectator * Spot On Star Struck Stepping Stones Swing Tilden Transition † Vibe Zari CR	D	Compass CR Coterie Eclat Weave Hologram Island Masquerade Menagerie Satelite Satin Chisel Tara Theory Woodland Zoom	E	Highland Ikat Stripe Ikat Square Kampala Katazome Kimono Luberon Mamba Marquee Meroe Sherman Shima Tryst Whip
----------	--	----------	--	----------	--	----------	---	----------	--

Spinneybeck Leather

F	Atelier Calais Cotton Velvet Coco Cornaro Eclipse Icon Intrigue Liberty Mod Plaid Rivington Soon Topography Totem Tweed Frieze	H	Arno † Constance Firefly Gezelle Magritte Rosemond	I	Byron Cato Diamond Days Digi Velvet Dynamic Gates Knoll Velvet Piper Ravello Tudor Vermeer Walker Worth Zimba	U	Vicenza † Volo †	V	Acqua † Andes † Embossed Tipped España † Hand Tipped † Velluto Pelle †	W	Alaska † Amazon † Antique † Arizona Derby † Forte † Lucente Sabrina †	X	Ducale Ducale Velour †	Y	Capri † Cervo Copenhagen † Cordovan † Distressed † Marissa † Prima † Riva † Saddle †
----------	--	----------	---	----------	--	----------	---------------------	----------	---	----------	--	----------	---------------------------	----------	--

* Approved for 2162P only.

Check with your KnollTextiles or Spinneybeck Representative for additions or changes.

Joseph Paul D'Urso

Residential Lounge Seating

Designer(s):
Joseph Paul D'Urso, 2008



description	width	depth	height	seat h, max	arm h, max	type	textile fabric yards	leather sq ft	weight
2162R Residential Sofa, same upholstery, frame and cushions	90"	40 1/2"	28 1/2"	15 3/8"	20 7/8"		14	250	151 lbs.
2162R Residential Sofa, combination upholstery, frame and cushions	90"	40 1/2"	28 1/2"	15 3/8"		frame uph.	6.7	110	
						upchg, cushions	7.7	145	
2163R Residential Ottoman, same upholstery, frame and cushions	28 1/2"	28 1/2"	14"	14"			3.5	45	26 lbs.
2163R Residential Ottoman, combination upholstery, frame and cushions	28 1/2"	28 1/2"	14"	14"		frame uph.	1.4	15	
						upchg, cushions	2.8	30	
2162P Optional side cushion for residential sofa	21"	5"	11"				1	n/a	6 lbs.

Order Code

<i>Example:</i>	2160R-OE-K162/25
2160R	D'Urso Residential Lounge Collection, lounge chair
OE	Ebonized legs
K162/25	Classic Boucle, Aegean
<i>Example:</i>	21623R-0313-S-K1152/8-K1024/3
2163R	D'Urso Residential Lounge Collection, ottoman
0313	Burnt Walnut legs
S	Split upholstery
K1152/8	Surround in Stirling, Cobble
K1024/3	Cushions in Coco, Ciel

Specify:

1. Pattern number
2. Leg finish
3. Textile selection

Specify with split upholstery:

1. Pattern number
2. Leg finish
3. Split upholstery option
4. Textile selection, Surround
5. Textile selection, Cushions

Ordering Information

Leg finishes:
Burnt Walnut on Oak (suffix 0313)
Clear Oak (suffix OC)
Ebonized on Oak (suffix OE)
Polished Chrome (suffix C)

Upholstery/COM information:
Prices shown includes fabric or leather upholstery. Contact your Knoll representative for colors. Only approved KnollTextiles and Spinneybeck leathers may be ordered.

Customer's Own Material is available pending approval. For approval requirements, processing instructions and ordering information please see page 18.

Maintenance:
See pages 28-29.

Construction

Frame:
Constructed of plywood with sinuous spring seat suspension and matrix back suspension. Standard lounge chair and sofa depth is 36"; residential sofa is 40" deep.

Upholstery:
One seat and back cushion for the Lounge Chair, two seat and back cushions for the Sofa, one semi-attached cushion for Ottoman. For units with combination upholstery, add list price of surround in appropriate grade with the list price of cushions to obtain total list price for item.

Railroad upholstery application is standard for all non-directional textiles. Please see 'Stitching' for seam details.

Cushions:
Seat cushions constructed of highly resilient polyurethane foam and polyester fiber, wrapped in polyester fiber batting. Back cushion constructed with a soft polyurethane foam core and polyester fiber fill. Side cushion constructed of 10/90 down with a down proof ticking.

Leather cushions feature a perforated zipper breather panel.

Stitching:
Non-directional textiles with railroad application, single needle topstitch for arms, double needle topstitch for seat and back cushions; directional textiles, single needle topstitch for arms, double needle topstitch for seat and back cushions, single blind stitch for vertical seams of seat cushion, a vertical single blind center seam joins inside and outside back panels of the sofa; leather, single needle topstitch for arms, double needle topstitch for seat and back cushions, single blind stitch for vertical seams of seat cushion, a vertical double needle topstitch seam joins inside and outside back panels of sofa. Ottoman; all applications, double needle topstitch for horizontal cushion seams, single blind seam for vertical seams of seat cushion.

Legs:
4" steel leg, 1 1/4" diameter, available in polished chrome with black nylon glides, or 4" turned solid oak leg available in natural oak, medium walnut on oak and ebonized oak with white nylon glides.

pattern no.	grade A	COM B	C	D	E	F	G	H	I	COL U	V	W	X	Y
2162R-(-)(-)	\$7,895.	\$8,240.	\$8,567.	\$8,927.	\$9,221.	\$9,434.	\$9,794.	\$10,481.	\$10,988.	\$14,581.	\$15,768.	\$18,183.	\$18,684.	\$19,271.
2162RS-(-)(-)(-)	6,023.	6,287.	6,536.	6,811.	7,036.	7,199.	7,473.	7,997.	8,384.	10,461.	11,314.	13,046.	13,406.	13,827.
upchg, cushions	2,582.	2,694.	2,802.	2,920.	3,015.	3,084.	3,203.	3,427.	3,594.	4,484.	4,848.	5,592.	5,745.	5,926.
2163R-(-)(-)	2,457.	2,557.	2,652.	2,757.	2,843.	2,906.	3,010.	3,211.	3,360.	3,815.	4,028.	4,463.	4,554.	4,660.
2163RS-(-)(-)(-)	1,874.	1,952.	2,023.	2,103.	2,169.	2,218.	2,297.	2,450.	2,563.	2,737.	2,891.	3,203.	3,266.	3,343.
upchg, cushions	803.	836.	867.	902.	930.	950.	985.	1,051.	1,098.	1,173.	1,239.	1,373.	1,401.	1,434.
2162P-(-)	453.	478.	500.	525.	545.	560.	585.	633.	668.					

Approved KnollTextiles Grades/Fabrics

A	Alignment ‡ Beacon Bocce Cat's Cradle Common Ground Commuter Cloth ‡ Delite Dristi Hourglass Mariner Monarch ‡ Prep ‡ Presto ‡ Sonnet Stacks Trophy	B	continued Mini Stitch ‡ Night Life Nonchalant CR Paradigm Pogo Pop Prairie Prim Radiance Ransom Ricochet ‡ Rush Hour Spark ‡ Spree Starry Night ‡ Summit Sutton Synth Tabloid Venue Versa Vinyl Westwood Wide Angle ‡ Zephyr Zipline	C	continued Echo Empire Stripe Emmesh ‡ Entourage Fable CR Fibra Hudson Hula Hoop Kaleidoscope CR Kora CR Lagos Legend CR Lore CR Metro Milestone Moto CR Palisade Panache CR Quark Regard CR Roundtrip Sahara Sandpiper Sequin CR Spectator * Spot On Star Struck Stepping Stones Swing Tilden Transition ‡ Vibe Zari CR	D	Compass CR Coterie Eclat Weave Hologram Island Masquerade Menagerie Satelite Satin Chisel Tara Theory Woodland Zoom	E	Highland Ikat Stripe Ikat Square Kampala Katazome Kimono Luberon Mamba Marquee Meroe Sherman Shima Tryst Whip
----------	--	----------	--	----------	--	----------	---	----------	--

Spinneybeck Leather

U	Vicenza ‡ Volo ‡	X	Ducale Ducale Velour ‡
V	Acqua ‡ Andes ‡ Embossed Tipped España ‡ Hand Tipped ‡ Velluto Pelle ‡	Y	Capri ‡ Cervo Copenhagen ‡ Cordovan ‡ Distressed ‡ Marissa ‡ Prima ‡ Riva ‡ Saddle ‡
W	Alaska ‡ Amazon ‡ Antique ‡ Arizona Derby ‡ Forte ‡ Lucente Sabrina ‡		

* Approved for 2162P only.

Check with your KnollTextiles or Spinneybeck Representative for additions or changes.

Joseph Paul D'Urso Swivel Lounge Seating

	description	seat h, min	seat h, max	w	d	h, min	h, max	textile fabric yds.	req. leather sq. ft.	weight
<i>Designer(s):</i> Joseph Paul D'Urso, 2008	2165 Swivel Lounge chair	17"	20"	32"	30"	25 3/4"	28 3/4"	4.25	100	52 lbs.

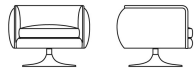

Order Code

<i>Example:</i>	2165-RC-AP-K1320/4
2165	Joseph Paul D'Urso Swivel lounge
RC	Return to center mechanism
AP	Polished Aluminum
K1320/4	Cornaro, Tabasco

Note:

The Joseph Paul D'Urso Swivel lounge chair is part of a collection. Please refer to the Joseph Paul D'Urso Lounge and Table Collections on pages 100, 104, 312, 314 and 318.

Specify:

1. Pattern number
2. Return to center mechanism, option
3. Frame finish
4. Textile selection

Ordering Information

Frame finish:
Polished Aluminum (suffix AP)
Textured Black (suffix TB)
Warm White (suffix WW)

Upholstery/COM information:
Prices shown include fabric upholstery. Contact your Knoll representative for colors. Only approved KnollTextiles may be ordered.

Customer's Own Material in textile applications is limited.

For approval requirements, processing instructions and ordering information please see page 18.

Maintenance:
See pages 28-29.

Note:
The KnollStudio logo and signature of Joseph Paul D'Urso are located on the underside of chair.

Construction

Frame:
Inner frame of solid wood and bent laminate plywood.

Base:
Die cast aluminum base available in polished aluminum or powder coat paint finish.

Upholstery:
Textile application must be railroded. Urethane foam with polyester top layer wraps interior frame and a fully upholstered panel surrounds chair.

Leather upholstery features two vertical double-needle top stitched seams on the outside back of the chair.

Cushion:
Urethane foam with polyester fiber wrap. Case with a single needle-top stitch detail.

pattern no.	grades A	COM B	C	D	E	F	G	H	I	U	V	W	X	Y
2165-(-)(-)(-)	\$2,984.	\$3,085.	\$3,182.	n/a	n/a	\$3,438.	n/a	\$3,747.	\$3,896.	n/a	\$6,022.	\$6,819.	n/a	\$7,179.

Approved KnollTextiles Grades/Fabrics

Spinneybeck Leather

Control:

360° Swivel mechanism with pneumatic seat height adjustment, cable operated with a low profile lever, flush mounted on the underside of the chair.

Return to center mechanism:

Optional return to center mechanism allows for 360° swivel movement and returns to a center position when not engaged. Available as fixed height only with an 19" seat height and a 27 3/4" overall height.

To specify return to center mechanism, add suffix RC following parent pattern number.





A Mariner Sonnet	F Coco Cornaro Cuddle Cloth Rivington
B Bankshot Knoll Felt ‡ Knoll Hopsack Sutton	H Arno Bavaria
C Classic Boucle	I Aswan Cato North Island Vermeer
E Highland	

V Andes Espana	Y Cordovan Marissa Prima Riva Torello
W Arizona Sabrina	

Check with your KnollTextiles Representative for changes or additions.

Raul de Armas

de Armas Chair

Designer(s): Raul de Armas, 1991	description	seat h	arm h	w	d	h	textile	req.	weight	finish
							fabric yds/ welt	leather sq. ft.		
	38A Arm chair, upholstered seat, no welt	17 1/2"	25 1/2"	21 1/4"	22 1/2"	33 1/2"	0.7/1.4	13	17 lbs.	other finishes
	38AW Arm chair, upholstered seat, with welt	17 1/2"	25 1/2"	21 1/4"	22 1/2"	33 1/2"	0.7/1.4	13	16 lbs.	maple
	 									
	38AW-U Arm chair, fully upholstered, with welt	17 1/2"	25 1/2"	21 1/4"	22 1/2"	33 1/2"	1.5	27	18 lbs.	other finishes
	 	17 1/2"	25 1/2"	21 1/4"	22 1/2"	33 1/2"	1.5	27	17 lbs.	maple

Order Code

<i>Example:</i>	38A-B319-K787/174
38A	de Armas arm chair, upholstered seat
B319	Medium Cherry
K787/174	Calais Cotton Velvet, Black Plum

Specify:

1. Pattern number
2. Finish selection
3. Cal 133 Fire Code option
4. Textile selection

Ordering Information:

Maple:
Clear Maple (suffix KC)

Beech frame stains:
Beech (suffix B311)
Bronzed Cherry (suffix B312A)
Burnt Walnut (suffix B313)
Deep Red Mahogany (suffix B328)
Ebonized (suffix BE)
Light Cherry (suffix B315)
Medium Cherry (suffix B319)
Medium Red Mahogany (suffix BR)
Medium Walnut (suffix B323)
Natural Beech (suffix BN)
Warm Brown Walnut (suffix J)

Ordering Information

Upholstery/COM information:
Prices shown include fabric or leather upholstery. Contact your Knoll representative for colors. Only approved KnollTextiles and Spinneybeck leathers may be ordered.

Customer's Own Material is available pending approval. For approval requirements, processing instructions and ordering information please see page 18.

KnollStudio wood finishes:
KnollStudio wood finishes complement a large variety of KnollStudio veneer and Knoll Office veneer finishes. To select correct complementary finish, please refer to KnollStudio Wood Finish Matrix on page 25. Complimentary finishes are available at no upcharge. If no complementary standard finish is available, please refer to custom finish policy below.

Custom finishes:
To complement non-Knoll wood veneer or lumber finishes, a one-time, non-negotiable net upcharge of \$618 applies. Re-orders are at no upcharge.

Please contact your KnollStudio representative, dealer or Customer Service associate for complete custom finish information and Order Code. Minimum order quantity for any custom finish order: 4 chairs.

Cal 133 Fire Code ▲ :
The de Armas Chairs comply with the California Technical Bulletin 133 standard if upholstered in Cal 133 approved upholstery. Specify suffix -C at end of pattern number and suffix -133 at end of textile selection. Upcharge applies, see page 18.

Certified Wood:
Chairs manufactured using FSC certified hardwoods are available through Custom Product Development. Extended leadtime and upcharge apply.

Maintenance:
See pages 28-29.

Note:
The de Armas Chair is Greenguard certified.

Construction

Frame:
Select clear maple hardwood in clear finish or select beech hardwood in stained finish.

Finish:
Catalyzed lacquer protective coating. Hand-applied final wax coating.

Seat:
Highly elastic woven membrane suspension with polyurethane foam insert.

Upholstery:
Inset seat available with optional welt detail. Fully upholstered features inset back with welt detail.

Glides:
Recessed plastic glides.

High Traffic Areas:
When specifying armless chair in high use or high traffic areas, we recommend the use of a stretcher for added strength. Contact CPD or your KnollStudio sales representative for more information.

pattern no.	grades A	COM B	C	D	E	F	G	H	I	COL U	V	W	X	Y
38A-() or 38AW-()	\$1,343.	\$1,368.	\$1,395.	\$1,411.	\$1,428.	\$1,445.	\$1,461.	\$1,505.	\$1,576.	\$1,742.	\$1,842.	\$2,037.	\$2,080.	\$2,125.
38A-KC or 38AW-KC	1,475.	1,499.	1,525.	1,543.	1,559.	1,576.	1,592.	1,634.	1,707.	1,873.	1,973.	2,167.	2,211.	2,257.
38AW-U-()	2,012.	2,054.	2,094.	2,140.	2,175.	2,202.	2,246.	2,333.	2,395.	2,639.	2,789.	3,099.	3,164.	3,237.
38AW-U-KC	2,205.	2,247.	2,288.	2,335.	2,369.	2,396.	2,440.	2,526.	2,588.	2,833.	2,983.	3,292.	3,359.	3,431.

Approved KnollTextiles Grades/Fabrics

A	Alignment *▲	Analogy *	Beacon	Bocce *	Cat's Cradle *	Chance	Common Ground *	Commuter Cloth ▲	Delite *	Dristi *	Foil Rap *	Heavy Metal *	Hourglass	Mariner *	Metaphor *	Monarch *▲	Prep *▲	Presto *▲	Sonnet	Stacks *	Trophy																	
B	Abacus *▲	Argyle *	Backdrop **	Bank Shot *	Belize *	Betwixt *▲	Bistro▲	Boundary▲	Cameo	Chroma *▲	Chronicle	Close Knit *	Digit *	Dovetail *▲	Fast Forward **	Ferry	Forza *																					
C	Gala II	Grandview	Grande *	Holbrook *	Journey	Keaton	Knoll Felt *	Knoll Hopsack *	Ludlow *	Lyric *	Mini Stitch *▲	Night Life *	Nonchalant CR *	Paradigm *	Petal Pusher *	Pop *	Prairie	Prim▲	Radiance *	Ransom	Ricochet *▲	Roam	Rush Hour	Soiree	Spark *▲	Spree	Starry Night *▲	Summit	Sutton▲	Synth	Tabloid *	Utmost *	Venue	Versa	Vinyl *	Westwood *	Wide Angle *▲	Zephyr *
C continued	Axiom	Atlas *	Autobahn *	Baxter	Biota *	Cairo	Charm *	Circa *	Classic Boucle *	Dahlia CR	Decade *	Durand	Earthwork *	Echo *	Empire Stripe *	Enmesh *▲	Entourage *	Fable CR *	Fibra *	Greenwich	Hudson	Hula Hoop *	Kaleidoscope CR *	Kora CR *	Lagos	Legend CR *	Lore CR *	Magnolia *	Metro *	Milestone	Moto CR *	Noble	Palisade *	Panache CR *				
D	Compass CR *	Coterie	Eclat Weave *	Hologram *	In The Loop **	Island	Masquerade *	Menagerie	Origins	Satellite *	Satin Chisel *	Tara *	Theory	Woodland	Zoom *																							
E	Highland *	Ikat Stripe	Ikat Square	Kampala	Katazome	Kimono *	Luberon *	Mamba *	Marquee	Meroe	Sherman	Shima	Tryst	Whip *																								
F	Atelier	Biscayne	Calais Cotton	Velvet *	Century *	Coco **	Cornaro *	Djenne	Eclipse *	Glider	Icon *	Intrigue	Liberty *	Mod Plaid	Rivington *▲	Soon	Topography *	Totem	Tweed Frieze *																			
G	Arabella	Arber	Gibson *	Hampshire **	Haze *	Kamani																																

Spinneybeck Leather

U	Vicenza *▲	Volo *▲											
V	Acqua *▲	Andes *▲	Embossed Tipped *	España *▲	Hand Tipped **	Velluto Pelle *▲							
W	Alaska *▲	Amazon *▲	Antique *▲	Arizona *▲	Derby **▲	Forte *▲	Lucente	Sabrina *▲					
X	Ducale **▲	Ducale Velour **▲											
Y	Capri *▲	Cervo *	Copenhagen *▲	Cordovan *▲	Distressed *▲	Lucca *	Marissa **▲	Portofino **	Prima *▲	Riva *▲	Saddle **▲	Salon **▲	Torello *

* Approved for fully upholstered versions.
 ** Approved for seat pad with no welting only.
 ▲ Approved for Cal 133 upholstery.

Check with your KnollTextiles or Spinneybeck Representative for changes or additions.

Raul de Armas de Armas Chair

	description	seat h	arm h	w	d	h	textile	req.	weight	finish
							fabric	leather		
							yds/ welt	sq. ft.		
<i>Designer(s):</i> Raul de Armas, 1991	38C Armless chair, upholstered seat, no welt	17 1/2"		21 1/4"	22 1/2"	33 1/2"	0.7/1.4	13	15 lbs.	other
	38CW Armless chair, upholstered seat, with welt	17 1/2"		21 1/4"	22 1/2"	33 1/2"	0.7/1.4	13	15 lbs.	maple



Order Code

<i>Example:</i>	38A-B319-K787/174
38A	de Armas arm chair, upholstered seat
B319	Medium Cherry
K787/174	Calais Cotton Velvet, Black Plum

Specify:

1. Pattern number
2. Finish selection
3. Cal 133 Fire Code option
4. Textile selection

Ordering Information:

Maple:
Clear Maple (suffix KC)

Beech frame stains:
Beech (suffix B311)
Bronzed Cherry (suffix B312A)
Burnt Walnut (suffix B313)
Deep Red Mahogany (suffix B328)
Ebonized (suffix BE)
Light Cherry (suffix B315)
Medium Cherry (suffix B319)
Medium Red Mahogany (suffix BR)
Medium Walnut (suffix B323)
Natural Beech (suffix BN)
Warm Brown Walnut (suffix J)

Ordering Information

Upholstery/COM information:
Prices shown include fabric or leather upholstery. Contact your Knoll representative for colors. Only approved KnollTextiles and Spinneybeck leathers may be ordered.

Customer's Own Material is available pending approval. For approval requirements, processing instructions and ordering information please see page 18.

KnollStudio wood finishes:
KnollStudio wood finishes complement a large variety of KnollStudio veneer and Knoll Office veneer finishes. To select correct complementary finish, please refer to KnollStudio Wood Finish Matrix on page 25. Complimentary finishes are available at no upcharge. If no complementary standard finish is available, please refer to custom finish policy below.

Custom finishes:
To complement non-Knoll wood veneer or lumber finishes, a one-time, non-negotiable net upcharge of \$618 applies. Re-orders are at no upcharge.

Please contact your KnollStudio representative, dealer or Customer Service associate for complete custom finish information and Order Code. Minimum order quantity for any custom finish order: 4 chairs.

Cal 133 Fire Code ▲ :
The de Armas Chairs comply with the California Technical Bulletin 133 standard if upholstered in Cal 133 approved upholstery. Specify suffix -C at end of pattern number and suffix -133 at end of textile selection. Upcharge applies, see page 18.

Certified Wood:
Chairs manufactured using FSC certified hardwoods are available through Custom Product Development. Extended leadtime and upcharge apply.

Maintenance:
See pages 28-29.

Note:
The de Armas Chair is Greenguard certified.

Construction

Frame:
Select clear maple hardwood in clear finish or select beech hardwood in stained finish.

Finish:
Catalyzed lacquer protective coating. Hand-applied final wax coating.

Seat:
Highly elastic woven membrane suspension with polyurethane foam insert.

Upholstery:
Inset seat available with optional welt detail. Fully upholstered features inset back with welt detail.

Glides:
Recessed plastic glides.

High Traffic Areas:
When specifying armless chair in high use or high traffic areas, we recommend the use of a stretcher for added strength. Contact CPD or your KnollStudio sales representative for more information.

pattern no.	grades													
	A	B	C	D	E	F	G	H	I	U	V	W	X	Y
38C-() or 38CW-()	\$1,270.	\$1,296.	\$1,324.	\$1,340.	\$1,357.	\$1,372.	\$1,392.	\$1,431.	\$1,507.	\$1,674.	\$1,772.	\$1,967.	\$2,006.	\$2,054.
38C-KC or 38CW-KC	1,396.	1,422.	1,450.	1,466.	1,483.	1,499.	1,517.	1,557.	1,630.	1,800.	1,897.	2,092.	2,131.	2,181.

Approved KnollTextiles Grades/Fabrics

A	Alignment *▲	Analogy *	Beacon	Bocce *	Cat's Cradle *	Chance	Common Ground *	Commuter Cloth ▲	Delite *	Dristi *	Foil Rap *	Heavy Metal *	Hourglass	Mariner *	Metaphor *	Monarch *▲	Prep *▲	Presto *▲	Sonnet	Stacks *	Trophy																	
B	Abacus *▲	Argyle *	Backdrop **	Bank Shot *	Belize *	Betwixt *▲	Bistro ▲	Boundary ▲	Cameo	Chroma *▲	Chronicle	Close Knit *	Digit *	Dovetail *▲	Fast Forward **	Ferry	Forza *																					
B continued	Gala II	Grandview	Grande *	Holbrook *	Journey	Keaton	Knoll Felt *	Knoll Hopsack *	Ludlow *	Lyric *	Mini Stitch *▲	Night Life *	Nonchalant CR *	Paradigm *	Petal Pusher *	Pop *	Prairie	Prim ▲	Radiance *	Ransom	Ricochet *▲	Roam	Rush Hour	Soiree	Spark *▲	Spree	Starry Night *▲	Summit	Sutton ▲	Synth	Tabloid *	Utmost *	Venue	Versa	Vinyl *	Westwood *	Wide Angle *▲	Zephyr *
C	Axiom	Atlas *	Autobahn *	Baxter	Biota *	Cairo	Charm *	Circa *	Classic Boucle *	Dahlia CR	Decade *	Durand	Earthwork *	Echo *	Empire Stripe *	Enmesh *▲	Entourage *	Fable CR *	Fibra *	Greenwich	Hudson	Hula Hoop *	Kaleidoscope CR *	Kora CR *	Lagos	Legend CR *	Lore CR *	Magnolia *	Metro *	Milestone	Moto CR *	Noble	Palisade *	Panache CR *				
C continued	Posh *	Quark *	Regard CR *	Roundtrip *	Sahara *	Sandpiper **	Sequin CR *	Sinclair	Smart *	Spectator *	Spot On	Star Struck *	Stepping Stones *	Swing *	Tight Rope	Tilden	Tower Grid	Transition *▲	Treble CR *	Vibe *	Zari CR *																	
D	Compass CR *	Coterie	Eclat Weave *	Hologram *	In The Loop **	Island	Masquerade *	Menagerie	Origins	Satellite *	Satin Chisel *	Tara *	Theory	Woodland	Zoom *																							
E	Highland *	Ikat Stripe	Ikat Square	Kampala	Katazome	Kimono *	Luberon *	Mamba *	Marquee	Meroe	Sherman	Shima	Tryst	Whip *																								
F	Atelier	Biscayne	Calais Cotton	Velvet *	Century *	Coco **	Cornaro *	Djenne	Eclipse *	Glider	Icon *	Intrigue	Liberty *	Mod Plaid	Rivington *▲	Soon	Topography *	Totem	Tweed Frieze *																			
G	Arabella	Arber	Gibson *	Hampshire **	Haze *	Kamani																																
G continued	Kinabalu	Kingston *	Melange *	Metallic Gloss *	Sablon	Serendipity	Spencer *	Straie Stripe *	Ultrasede *▲	Utrillo																												
H	Arno *	Bavaria **	Constance	Firefly	Gezelle	Magritte	Rosemond																															
I	Aswan	Byron *	Canaan *	Cato **	Cummings *	Diamond Days	Digi Velvet *	Dynamic	Gates *	Ita *	Jaipur *	Knoll Velvet *▲	Mepal *	North Island **	Olema	Piper	Ravello *	Rutledge	Sandis *	Tudor	Walker *	Worth **	Vermeer	Zimba														

Spinneybeck Leather

U	Vicenza *▲	Volo *▲											
V	Acqua *▲	Andes *▲	Embossed Tipped *▲	España *▲	Hand Tipped **	Velluto Pelle *▲							
W	Alaska *▲	Amazon *▲	Antique *▲	Arizona *▲	Derby **▲	Forte *▲	Lucente	Sabrina *▲					
X	Ducale **▲	Ducale Velour **▲											
Y	Capri *▲	Cervo *	Copenhagen *▲	Cordovan *▲	Distressed *▲	Lucca *	Marissa **▲	Portofino **	Prima *▲	Riva *▲	Saddle **▲	Salon **▲	Torello *

* Approved for fully upholstered versions.

** Approved for seat pad with no welting only.

▲ Approved for Cal 133 upholstery.

Check with your KnollTextiles or Spinneybeck Representative for changes or additions.

Raul de Armas de Armas Chair

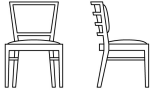
Designer(s): Raul de Armas, 1991	description	seat h	arm h	w	d	h	textile	req.	weight	finish
							fabric yds/ welt	leather sq. ft.		
	38CW-U Armless chair, fully upholstered, with welt	17 1/2"		21 1/4"	22 1/2"	33 1/2"	1.5	27	16 lbs.	other finishes
			17 1/2"		21 1/4"	22 1/2"	33 1/2"	1.5	27	16 lbs.
	38R Seat basket replacement						0.7/1.4	13		

Order Code

<i>Example:</i>	38A-B319-K787/174
38A	de Armas arm chair, upholstered seat
B319	Medium Cherry
K787/174	Calais Cotton Velvet, Black Plum

Specify:

1. Pattern number
2. Finish selection
3. Cal 133 Fire Code option
4. Textile selection

Ordering Information:

Maple:
Clear Maple (suffix KC)

Beech frame stains:
Beech (suffix B311)
Bronzed Cherry (suffix B312A)
Burnt Walnut (suffix B313)
Deep Red Mahogany (suffix B328)
Ebonized (suffix BE)
Light Cherry (suffix B315)
Medium Cherry (suffix B319)
Medium Red Mahogany (suffix BR)
Medium Walnut (suffix B323)
Natural Beech (suffix BN)
Warm Brown Walnut (suffix J)

Ordering Information

Upholstery/COM information:
Prices shown include fabric or leather upholstery. Contact your Knoll representative for colors. Only approved KnollTextiles and Spinneybeck leathers may be ordered.

Customer's Own Material is available pending approval. For approval requirements, processing instructions and ordering information please see page 18.

KnollStudio wood finishes:
KnollStudio wood finishes complement a large variety of KnollStudio veneer and Knoll Office veneer finishes. To select correct complementary finish, please refer to KnollStudio Wood Finish Matrix on page 25. Complimentary finishes are available at no upcharge. If no complementary standard finish is available, please refer to custom finish policy below.

Custom finishes:
To complement non-Knoll wood veneer or lumber finishes, a one-time, non-negotiable net upcharge of \$618 applies. Re-orders are at no upcharge.

Please contact your KnollStudio representative, dealer or Customer Service associate for complete custom finish information and Order Code. Minimum order quantity for any custom finish order: 4 chairs.

Cal 133 Fire Code ▲ :
The de Armas Chairs comply with the California Technical Bulletin 133 standard if upholstered in Cal 133 approved upholstery. Specify suffix -C at end of pattern number and suffix -133 at end of textile selection. Upcharge applies, see page 18.

Certified Wood:
Chairs manufactured using FSC certified hardwoods are available through Custom Product Development. Extended leadtime and upcharge apply.

Maintenance:
See pages 28-29.

Note:
The de Armas Chair is Greenguard certified.

Construction

Frame:
Select clear maple hardwood in clear finish or select beech hardwood in stained finish.

Finish:
Catalyzed lacquer protective coating. Hand-applied final wax coating.

Seat:
Highly elastic woven membrane suspension with polyurethane foam insert.

Upholstery:
Inset seat available with optional welt detail. Fully upholstered features inset back with welt detail.

Glides:
Recessed plastic glides.

High Traffic Areas:
When specifying armless chair in high use or high traffic areas, we recommend the use of a stretcher for added strength. Contact CPD or your KnollStudio sales representative for more information.

pattern no.	grades													
	A	B	C	D	E	F	G	H	I	U	V	W	X	Y
38CW-U- ()	\$1,811.	\$1,851.	\$1,893.	\$1,937.	\$1,975.	\$2,001.	\$2,046.	\$2,128.	\$2,194.	\$2,444.	\$2,594.	\$2,889.	\$2,968.	\$3,042.
38CW-U-KC	1,984.	2,025.	2,066.	2,112.	2,149.	2,173.	2,220.	2,302.	2,367.	2,617.	2,768.	3,064.	3,144.	3,217.
38R- ()	412.	435.	464.	479.	497.	512.	528.	571.	642.	813.	911.	1,104.	1,147.	1,192.

Approved KnollTextiles Grades/Fabrics

A	Alignment *▲ Analogy * Beacon Bocce * Cat's Cradle * Chance Common Ground * Commuter Cloth ▲ Delite * Dristi * Foil Rap * Heavy Metal * Hourglass Mariner * Metaphor * Monarch *▲ Prep *▲ Presto *▲ Sonnet Stacks * Trophy	B continued Gala II Grandview Grande * Holbrook * Keaton Knoll Felt * Knoll Hopsack * Ludlow * Lyric * Mini Stitch *▲ Night Life * Nonchalant CR * Paradigm * Petal Pusher * Pop * Prairie Prim ▲ Radiance * Ransom Ricochet *▲ Roam Rush Hour Soiree Spark *▲ Spree Starry Night *▲ Summit Sutton ▲ Synth Tabloid * Utmost * Venue Versa Vinyl * Westwood * Wide Angle *▲ Zephyr *	C Axiom Atlas * Autobahn * Baxter Biota * Cairo Charm * Circa * Classic Boucle * Dahlia CR Decade * Durand Earthwork * Echo * Empire Stripe * Enmesh *▲ Entourage * Fable CR * Fibra * Greenwich Hudson Hula Hoop * Kaleidoscope CR * Kora CR * Lagos Legend CR * Lore CR * Magnolia * Metro * Milestone Moto CR * Noble Palisade * Panache CR *	C continued Posh * Quark * Regard CR * Roundtrip * Sahara * Sandpiper * * Sequin CR * Sinclair Smart * Spectator * Spot On Star Struck * Stepping Stones * Swing * Tight Rope Tilden Tower Grid Transition *▲ Treble CR * Vibe * Zari CR *	D Compass CR * Coterie Eclat Weave * Hologram * In The Loop * * Island Masquerade * Menagerie Origins Satellite * Satin Chisel * Tara * Theory Woodland Zoom *
----------	--	---	---	--	--

Spinneybeck Leather

E Highland * Ikat Stripe Ikat Square Kampala Katazome Kimono * Luberon * Mamba * Marquee Meroe Sherman Shima Tryst Whip *	F Atelier Biscayne Calais Cotton Velvet * Century * Coco * * Cornaro * Djenne Eclipse * Glider Icon * Intrigue Liberty * Mod Plaid Rivington *▲ Soon Topography * Totem Tweed Frieze *	G continued Kinabalu Kingston * Melange * Metallic Gloss * Sablon Serendipity Spencer * Straie Stripe * Ultrasuede *▲ Utrillo	H Arno * Bavaria * * Constance Firefly Gezelle Magritte Rosemond	I Aswan Byron * Canaan * Cato * * Cummings * Diamond Days Digi Velvet * Dynamic Gates * Ita * Jaipur * Knoll Velvet *▲ Mepal * North Island * * Olema Piper Ravello * Rutledge Sandis * Tudor Walker * Worth * * Vermeer Zimba	U Vicenza *▲ Volo *▲	V Acqua *▲ Andes *▲ Embossed Tipped * España *▲ Hand Tipped * * Velluto Pelle *▲	W Alaska *▲ Amazon *▲ Antique *▲ Arizona *▲ Derby * *▲ Forte *▲ Lucente Sabrina *▲	X Ducale * *▲ Ducale Velour * *▲	Y Capri *▲ Cervo * Copenhagen *▲ Cordovan *▲ Distressed *▲ Lucca * Marissa * *▲ Portofino * * Prima *▲ Riva *▲ Saddle * *▲ Salon * *▲ Torello *
--	--	--	--	---	-----------------------------------	---	---	---	---

* Approved for fully upholstered versions.
* * Approved for seat pad with no wetting only.
▲ Approved for Cal 133 upholstery.

Check with your KnollTextiles or Spinneybeck Representative for changes or additions.

Raul de Armas

Vertical de Armas Chair

Designer(s):
Raul de Armas, 2000



description	seat h	arm h	w	d	h	textile	req.	weight	finish
						fabric yds/ welt	leather sq. ft.		
41A Arm chair, upholstered seat, no welt	17 1/2"	25 1/2"	21 1/4"	22 1/2"	33 1/2"	0.7/1.4	13	17 lbs.	other
41AW Arm chair, upholstered seat, with welt	17 1/2"	25 1/2"	21 1/4"	22 1/2"	33 1/2"	0.7/1.4	13	16 lbs.	finishes maple
41AW-U Arm chair, fully upholstered, with welt	17 1/2"	25 1/2"	21 1/4"	22 1/2"	33 1/2"	1.5	27	18 lbs.	other finishes
	17 1/2"	25 1/2"	21 1/4"	22 1/2"	33 1/2"	1.5	27	17 lbs.	maple
41R Seat basket replacement						0.7/1.4	13		

Order Code

<i>Example:</i>	41A-B319-K787/174
41A	de Armas arm chair
B319	Medium Cherry
K787/174	Calais Cotton Velvet, Black Plum

Specify:

1. Pattern number
2. Finish selection
3. Cal 133 Fire Code option
4. Textile selection

Ordering Information:

Maple:
Clear Maple (suffix KC)

Beech frame stains:

- Beech (suffix B311)
- Bronzed Cherry (suffix B312A)
- Burnt Walnut (suffix B313)
- Deep Red Mahogany (suffix B328)
- Ebonized (suffix BE)
- Light Cherry (suffix B315)
- Medium Cherry (suffix B319)
- Medium Red Mahogany (suffix BR)
- Medium Walnut (suffix B323)
- Natural Beech (suffix BN)
- Warm Brown Walnut (suffix J)

Ordering Information

Upholstery/COM information:

Prices shown include fabric or leather upholstery. Contact your Knoll representative for colors. Only approved KnollTextiles and Spinneybeck leathers may be ordered.

Customer's Own Material is available pending approval. For approval requirements, processing instructions and ordering information please see page 18.

KnollStudio wood finishes:

KnollStudio wood finishes complement a large variety of KnollStudio veneer and Knoll Office veneer finishes. To select correct complementary finish, please refer to KnollStudio Wood Finish Matrix on page 25. Complementary finishes are available at no upcharge. If no complementary standard finish is available, please refer to custom finish policy below.

Custom finishes:

To complement non-Knoll wood veneer or lumber finishes, a one-time, non-negotiable net upcharge of \$618 applies. Re-orders are at no upcharge.

Please contact your KnollStudio representative, dealer or Customer Service associate for complete custom finish information and Order Code. Minimum order quantity for any custom finish order: 4 chairs.

Cal 133 Fire Code ▲ :

The de Armas Chairs comply with the California Technical Bulletin 133 standard if upholstered in Cal 133 approved upholstery. Specify suffix -C at end of pattern number and suffix -133 at end of textile selection. Upcharge applies, see page 18.

Certified Wood:

Chairs manufactured using FSC certified hardwoods are available through Custom Product Development. Extended leadtime and upcharge apply.

Maintenance:

See pages 28-29.

Note:

The Vertical de Armas Chair is Greenguard certified.

Construction

Frame:

Select clear maple hardwood in clear finish or select beech hardwood in stained finish.

Finish:

Catalyzed lacquer protective coating. Hand-applied final wax coating.

Seat:

Highly elastic woven membrane suspension with polyurethane foam insert.

Upholstery:

Inset seat available with optional welt detail. Fully upholstered features inset back with welt detail.

Glides:

Recessed plastic glides.

High Traffic Areas:

When specifying armless chair in high use or high traffic areas, we recommend the use of a stretcher for added strength. Contact CPD or your KnollStudio sales representative for more information.

pattern no.	grades A	COM B	C	D	E	F	G	H	I	COL U	V	W	X	Y
41A-() or 41AW-()	\$1,343.	\$1,368.	\$1,395.	\$1,411.	\$1,428.	\$1,445.	\$1,461.	\$1,505.	\$1,576.	\$1,742.	\$1,842.	\$2,037.	\$2,080.	\$2,125.
41A-KC or 41AW-KC	1,475.	1,499.	1,525.	1,543.	1,559.	1,576.	1,592.	1,634.	1,707.	1,873.	1,973.	2,167.	2,211.	2,257.
41AW-U-()	2,012.	2,054.	2,094.	2,140.	2,175.	2,202.	2,246.	2,333.	2,395.	2,639.	2,789.	3,099.	3,164.	3,237.
41AW-U-KC	2,205.	2,247.	2,288.	2,335.	2,369.	2,396.	2,440.	2,526.	2,588.	2,833.	2,983.	3,292.	3,359.	3,431.
41R-()	412.	435.	464.	479.	497.	512.	528.	571.	642.	813.	911.	1,104.	1,147.	1,192.

Approved KnollTextiles Grades/Fabrics

A	Alignment *▲ Analogy * Beacon Bocce * Cat's Cradle * Chance Common Ground * Commuter Cloth ▲ Delite * Dristi * Foil Rap * Heavy Metal * Hourglass Mariner * Metaphor * Monarch *▲ Prep *▲ Presto *▲ Sonnet Stacks * Trophy	B continued Gala II Grandview Grande * Holbrook * Keaton Knoll Felt * Knoll Hopsack * Ludlow * Lyric * Mini Stitch *▲ Night Life * Nonchalant CR * Paradigm * Petal Pusher * Pop * Prairie Prim ▲ Radiance * Ransom Ricochet *▲ Roam Rush Hour Soiree Spark *▲ Spree Starry Night *▲ Summit Sutton ▲ Synth Tabloid * Utmost * Venue Versa Vinyl * Westwood * Wide Angle *▲ Zephyr *	C Axiom Atlas * Autobahn * Baxter Biota * Cairo Charm * Circa * Classic Boucle * Dahlia CR Decade * Durand Earthwork * Echo * Empire Stripe * Enmesh *▲ Entourage * Fable CR * Fibra * Greenwich Hudson Hula Hoop * Kaleidoscope CR * Kora CR * Lagos Legend CR * Lore CR * Magnolia * Metro * Milestone Moto CR * Noble Palisade * Panache CR *	C continued Posh * Quark * Regard CR * Roundtrip * Sahara * Sandpiper * * Sequin CR * Sinclair Smart * Spectator * Spot On Star Struck * Stepping Stones * Swing * Tight Rope Tilden Tower Grid Transition *▲ Treble CR * Vibe * Zari CR *	D Compass CR * Coterie Eclat Weave * Hologram * In The Loop * * Island Masquerade * Menagerie Origins Satellite * Satin Chisel * Tara * Theory Woodland Zoom *
----------	--	---	---	--	--

Spinneybeck Leather

E Highland * Ikat Stripe Ikat Square Kampala Katazome Kimono * Luberon * Mamba * Marquee Meroe Sherman Shima Tryst Whip *	F Atelier Biscayne Calais Cotton Velvet * Century * Coco * * Cornaro * Djenne Eclipse * Glider Icon * Intrigue Liberty * Mod Plaid Rivington *▲ Soon Topography * Totem Tweed Frieze *	G continued Kinabalu Kingston * Melange * Metallic Gloss * Sablon Serendipity Spencer * Straie Stripe * Ultrasuede *▲ Utrillo	H Arno * Bavaria * * Constance Firefly Gezelle Magritte Rosemond	I Aswan Byron * Canaan * Cato * * Cummings * Diamond Days Digi Velvet * Dynamic Gates * Ita * Jaipur * Knoll Velvet *▲ Mepal * North Island * * Olema Piper Ravello * Rutledge Sandis * Tudor Walker * Worth * * Vermeer Zimba	U Vicenza *▲ Volo *▲	V Acqua *▲ Andes *▲ Embossed Tipped * España *▲ Hand Tipped * * Velluto Pelle *▲	W Alaska *▲ Amazon *▲ Antique *▲ Arizona *▲ Derby * *▲ Forte *▲ Lucente Sabrina *▲	X Ducale * *▲ Ducale Velour * *▲	Y Capri *▲ Cervo * Copenhagen *▲ Cordovan *▲ Distressed *▲ Lucca * Marissa * *▲ Portofino * * Prima *▲ Riva *▲ Saddle * *▲ Salon * *▲ Torello *
--	--	--	--	---	-----------------------------------	---	---	---	---

* Approved for fully upholstered versions.
* * Approved for seat pad with no welting only.
▲ Approved for Cal 133 upholstery.

Check with your KnollTextiles or Spinneybeck Representative for changes or additions.

Raul de Armas

Vertical de Armas Chair

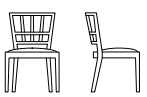
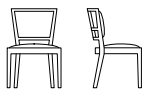
Designer(s) Raul de Armas, 2000	description	seat h	arm h	w	d	h	textile	leather	weight	finish	
							fabric yds/ welt	sq. ft.			
	41C Armless chair, upholstered seat, no welt	17 1/2"		21 1/4"	22 1/2"	33 1/2"	0.7/1.4	13	15 lbs.	other finishes	
	41CW Armless chair, upholstered seat, with welt	17 1/2"		21 1/4"	22 1/2"	33 1/2"	0.7/1.4	13	16 lbs.	maple	
											
											
	41CW-U Armless chair, fully upholstered, with welt	17 1/2"		21 1/4"	22 1/2"	33 1/2"	1.5	27	16 lbs.	other finishes	
		17 1/2"		21 1/4"	22 1/2"	33 1/2"	1.5	27	17 lbs.	maple	
	41R Seat basket replacement						0.7/1.4	13			

Order Code

<i>Example:</i>	41A-B319-K787/174
41A	de Armas arm chair
B319	Medium Cherry
K787/174	Calais Cotton Velvet, Black Plum

Specify:

1. Pattern number
2. Finish selection
3. Cal 133 Fire Code option
4. Textile selection

Ordering Information:

Maple:
Clear Maple (suffix KC)

Beech frame stains:

- Beech (suffix B311)
- Bronzed Cherry (suffix B312A)
- Burnt Walnut (suffix B313)
- Deep Red Mahogany (suffix B328)
- Ebonized (suffix BE)
- Light Cherry (suffix B315)
- Medium Cherry (suffix B319)
- Medium Red Mahogany (suffix BR)
- Medium Walnut (suffix B323)
- Natural Beech (suffix BN)
- Warm Brown Walnut (suffix J)

Ordering Information

Upholstery/COM information:

Prices shown include fabric or leather upholstery. Contact your Knoll representative for colors. Only approved KnollTextiles and Spinneybeck leathers may be ordered.

Customer's Own Material is available pending approval. For approval requirements, processing instructions and ordering information please see page 18.

KnollStudio wood finishes:

KnollStudio wood finishes complement a large variety of KnollStudio veneer and Knoll Office veneer finishes. To select correct complementary finish, please refer to KnollStudio Wood Finish Matrix on page 25. Complementary finishes are available at no upcharge. If no complementary standard finish is available, please refer to custom finish policy below.

Custom finishes:

To complement non-Knoll wood veneer or lumber finishes, a one-time, non-negotiable net upcharge of \$618 applies. Re-orders are at no upcharge.

Please contact your KnollStudio representative, dealer or Customer Service associate for complete custom finish information and Order Code. Minimum order quantity for any custom finish order: 4 chairs.

Cal 133 Fire Code ▲ :

The de Armas Chairs comply with the California Technical Bulletin 133 standard if upholstered in Cal 133 approved upholstery. Specify suffix -C at end of pattern number and suffix -133 at end of textile selection. Upcharge applies, see page 18.

Certified Wood:

Chairs manufactured using FSC certified hardwoods are available through Custom Product Development. Extended leadtime and upcharge apply.

Maintenance:

See pages 28-29.

Note:

The Vertical de Armas Chair is Greenguard certified.

Construction

Frame:

Select clear maple hardwood in clear finish or select beech hardwood in stained finish.

Finish:

Catalyzed lacquer protective coating. Hand-applied final wax coating.

Seat:

Highly elastic woven membrane suspension with polyurethane foam insert.

Upholstery:

Inset seat available with optional welt detail. Fully upholstered features inset back with welt detail.

Glides:

Recessed plastic glides.

High Traffic Areas:

When specifying armless chair in high use or high traffic areas, we recommend the use of a stretcher for added strength. Contact CPD or your KnollStudio sales representative for more information.

pattern no	grades		COM											
	A	B	C	D	E	F	G	H	I	COL U	V	W	X	Y
41C-() or 41CW-()	\$1,270.	\$1,296.	\$1,324.	\$1,340.	\$1,357.	\$1,372.	\$1,392.	\$1,431.	\$1,507.	\$1,674.	\$1,772.	\$1,967.	\$2,006.	\$2,054.
41C-KC or 41CW-KC	1,396.	1,422.	1,450.	1,466.	1,483.	1,499.	1,517.	1,557.	1,630.	1,800.	1,897.	2,092.	2,131.	2,181.
41CW-U-()	1,811.	1,851.	1,893.	1,937.	1,975.	2,001.	2,046.	2,128.	2,194.	2,444.	2,594.	2,889.	2,968.	3,042.
41CW-U-KC	1,984.	2,025.	2,066.	2,112.	2,149.	2,173.	2,220.	2,302.	2,367.	2,617.	2,768.	3,064.	3,144.	3,217.
41R-()	412.	435.	464.	479.	497.	512.	528.	571.	642.	813.	911.	1,104.	1,147.	1,192.

Approved KnollTextiles Grades/Fabrics

A	Alignment *▲	Analogy *	Beacon	Bocce *	Cat's Cradle *	Chance	Common Ground *	Commuter Cloth ▲	Delite *	Dristi *	Foil Rap *	Heavy Metal *	Hourglass	Mariner *	Metaphor *	Monarch *▲	Prep *▲	Presto *▲	Sonnet	Stacks *	Trophy													
B	Abacus *▲	Argyle *	Backdrop **	Bank Shot *	Belize *	Betwixt *▲	Bistro▲	Boundary▲	Cameo	Chroma *▲	Chronicle	Close Knit *	Digit *	Dovetail *▲	Fast Forward **	Ferry	Forza *																	
C	Axiom	Atlas *	Autobahn *	Baxter	Biota *	Cairo	Charm *	Circa *	Classic Boucle *	Dahlia CR	Decade *	Durand	Earthwork *	Echo *	Empire Stripe *	Enmesh *▲	Entourage *	Fable CR *	Fibra *	Greenwich	Hudson	Hula Hoop *	Kaleidoscope CR *	Kora CR *	Lagos	Legend CR *	Lore CR *	Magnolia *	Metro *	Milestone	Moto CR *	Noble	Palisade *	Panache CR *
C	continued	Posh *	Quark *	Regard CR *	Roundtrip *	Sahara *	Sandpiper **	Sequin CR *	Sinclair	Smart *	Spectator *	Spot On	Star Struck *	Stepping Stones *	Swing *	Tight Rope	Tilden	Tower Grid	Transition *▲	Treble CR *	Vibe *	Zari CR *												
D	Compass CR *	Coterie	Eclat Weave *	Hologram *	In The Loop **	Island	Masquerade *	Menagerie	Origins	Satellite *	Satin Chisel *	Tara *	Theory	Woodland	Zoom *																			

Spinneybeck Leather



E	Highland *	Ikat Stripe	Ikat Square	Kampala	Katazome	Kimono *	Luberon *	Mamba *	Marquee	Meroe	Sherman	Shima	Tryst	Whip *										
F	Atelier	Biscayne	Calais Cotton	Velvet *	Century *	Coco **	Cornaro *	Djenne	Eclipse *	Glider	Icon *	Intrigue	Liberty *	Mod Plaid	Rivington *▲	Soon	Topography *	Totem	Tweed Frieze *					
G	Arabella	Arber	Gibson *	Hampshire **	Haze *	Kamani																		
G	continued	Kinabalu	Kingston *	Melange *	Metallic Gloss *	Sablon	Serendipity	Spencer *	Straie Stripe *	Ultrasede *▲	Utrillo													
H	Arno *	Bavaria **	Constance	Firefly	Gezelle	Magritte	Rosemond																	
I	Aswan	Byron *	Canaan *	Cato **	Cummings *	Diamond Days	Digi Velvet *	Dynamic	Gates *	Ita *	Jaipur *	Knoll Velvet *▲	Mepal *	North Island **	Olema	Piper	Ravello *	Rutledge	Sandis *	Tudor	Walker *	Worth **	Vermeer	Zimba
U	Vicenza *▲	Volo *▲																						
V	Acqua *▲	Andes *▲	Embossed Tipped *	España *▲	Hand Tipped **	Velluto Pelle *▲																		
W	Alaska *▲	Amazon *▲	Antique *▲	Arizona *▲	Derby **▲	Forte *▲	Lucente	Sabrina *▲																
X	Ducale **▲	Ducale Velour **▲																						
Y	Capri *▲	Cervo *	Copenhagen *▲	Cordovan *▲	Distressed *▲	Lucca *	Marissa **▲	Portofino **	Prima *▲	Riva *▲	Saddle **▲	Salon **▲	Torello *											

* Approved for fully upholstered versions.
 ** Approved for seat pad with no wetting only.
 ▲ Approved for Cal 133 upholstery.

Check with your KnollTextiles or Spinneybeck Representative for changes or additions.

Frank Gehry

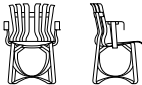
Side and Dining Chairs

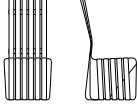
	description	seat h	arm h	w	d	h	textile fabric yds.	req. leather sq. ft.	weight
<i>Designer(s):</i> Frank Gehry, 1990	91A-GC Hat Trick arm chair 	18"	25 ⁷ / ₈ "	23 ³ / ₈ "	22 ¹ / ₄ "	33 ¹ / ₂ "			14 lbs.
		18"	25 ⁷ / ₈ "	23 ³ / ₈ "	22 ¹ / ₄ "	33 ¹ / ₂ "	0.8	15	14 lbs.
<i>Award(s):</i> ASID Award, 1992; ROSCOE Award, 1992; ID Magazine Gold Award, 1992; ICFE Award for Excellence, 1992; IBD Award (Silver), 1992; Premium Imperiale Award (Prince Takamatsu World Culture Award), 1992; Time Magazine, Best Design of 1992	91C-GC Hat Trick armless chair 	18"		20"	22 ¹ / ₄ "	33 ¹ / ₂ "			11 lbs.
		18"		20"	22 ¹ / ₄ "	33 ¹ / ₂ "	0.8	15	11 lbs.
	91K Seat cushion replacement for Hat Trick arm and armless chair						0.8	15	
	92C-GC High Sticking high back chair 	17 ⁷ / ₈ "		20 ¹ / ₈ "	23 ⁷ / ₈ "	43 ³ / ₈ "			12 lbs.
		17 ⁷ / ₈ "		20 ¹ / ₈ "	23 ⁷ / ₈ "	43 ³ / ₈ "	0.7	14	12 lbs.
	92K Seat cushion replacement						0.7	14	

Order Code

<i>Example:</i>	91A-GC-K-SA783
91A	Hat Trick arm chair
GC	Clear Maple
K	Seat cushion
SA783	Sabrina, Carmen
<i>Example:</i>	92K-K1320/4
92K	High sticking seat cushion replacement
K1320/4	Cornaro, Tabasco

Note:
The Gehry chairs are part of a collection. Please refer to Gehry tables on page 320.

Specify:

1. Pattern number
2. Finish selection
3. Textile selection

Seat cushion replacement, specify:

1. Pattern number
2. Textile selection

Ordering Information

Finishes:
Clear Maple (suffix GC)

Seat cushion option:
To specify seat cushion, add "K" to end of pattern number and then list textile/leather pattern number.

Upholstery/COM information:
Prices shown include fabric or leather upholstery. Contact your Knoll representative for colors. Only approved KnollTextiles and Spinneybeck leathers may be ordered.

Customer's Own Material is available pending approval. For approval requirements, processing instructions and ordering information please see page 18.

Hat Trick note:
Hat Trick arms are 9-ply and arm supports are a total of 26-ply for added strength. Arms may be retrofitted on armless Hat Trick chair, or removed from arm version. Easily added or removed with bolts. Contoured seat constructed of cross-ply maple for rigidity.

High Sticking note:
Built-in lumbar curve for enhanced back support. To maximize tension compression, limited assembly glue is used in woven seat: weaves flex in unison for spring-like comfort.

Note:
The underside of each piece is embossed with the Knoll logo and Frank Gehry's signature.

Maintenance:
See pages 28-29.

Construction

Frame:
Constructed of hard white maple veneers in 2" wide, ¹/₃₂" thick strips on Hat Trick and High Sticking chair, laminated to 7 to 9-ply thickness with high-bonding urea glue. All wood grains run in same direction for resilience. Thermo-set assembly glue provides structural rigidity without the need for metal connectors, while allowing for ergonomic movement and flexibility. Backs on all chairs flex for added comfort.

Cushions:
¹/₂" thick high resiliency foam on Hat Trick. ¹/₄" thick high resiliency foam on High Sticking. Hat Trick cushion "shower cap" design envelopes entire seat. Square High Sticking cushion snap-locks underneath chair.

Glides:
Clear plastic with matte frost finish.

pattern no.	unuphol.	grades A	COM B	C	D	E	F	G	H	I	COL U	V	W	X	Y
91A-GC	\$3,623.														
91A-GC-K		3,964.	3,984.	4,005.	4,026.	4,044.	4,057.	4,079.	4,119.	4,150.	4,259.	4,339.	4,497.	4,529.	4,568.
91C-GC	2,755.														
91C-GC-K		3,097.	3,118.	3,137.	3,159.	3,178.	3,189.	3,212.	3,254.	3,284.	3,395.	3,471.	3,630.	3,663.	3,701.
91K-()		410.	431.	449.	471.	490.	501.	524.	567.	596.	708.	785.	941.	975.	1,014.
92C-GC	4,736.														
92C-GC-K		5,078.	5,100.	5,118.	5,140.	5,158.	5,169.	5,192.	5,234.	5,264.	5,352.	5,425.	5,572.	5,602.	5,637.
92K-()		440.	461.	481.	502.	521.	531.	555.	597.	627.	715.	788.	934.	964.	999.

Approved KnollTextiles Grades/Fabrics



A	Alignment Beacon Bocce Chance Common Ground Commuter Cloth Delite Dristi Hourglass Mariner Prep Presto Soliloquy Sonnet Stacks Trophy	E continued Night Life Nonchalant CR Paradigm Pop Prairie Prim # Radiance Ransom Ricochet Roam Rush Hour Soiree Spark Spinoff Nuance Spree Starry Night Summit Sutton Synth Tabloid Utmost Venue Versa Vinyl Westwood Wide Angle Zephyr Zipline	C continued Earthwork Echo Empire Stripe Enmesh Entourage Fibra Greenwich Hudson Hula Hoop Kora CR Lagos Legend CR Lore CR Magnolia Metro Milestone Moto CR Noble Palisade Panache CR Quark Regard CR Roundtrip Sequin CR Sinclair Smart Spot On Star Struck Stepping Stones	C continued Swing Tilden Tower Grid Transition Treble CR Vibe Zari CR D Compass CR Coterie Eclat Weave Hologram Island Masquerade Menagerie Origins Satellite Satin Chisel Tara Theory Woodland Zoom E Highland Ikat Stripe Ikat Square Kampala Katazome Kimono Luberon Mamba Marquee Sherman Shima Tryst
B	Abacus Argyle Bank Shot Belize Betwixt Bistro Boundary Cameo Chroma Chronicle Close Knit Digit Dovetail Ferry Forza Gala II Grande Grandview Holbrook Journey Keaton Knoll Felt Knoll Hopsack Ludlow Lyric Mini Stitch	C Autobahn Biota Charm Circa Classic Boucle Dahlia CR Decade Dune Durand		

Spinneybeck Leather

U Vicenza Volo	V Acqua Andes Embossed Tipped España Velluto Pelle	W Alaska Amazon Antique Arizona Forte Lucente Sabrina	X Ducale Ducale Velour
Y Capri Cervo Copenhagen Cordovan Distressed Lucca Marissa Prima Riva			

Check with your KnollTextiles or Spinneybeck Representative for changes or additions.

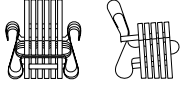
Frank Gehry Lounge Seating

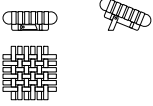
	description	seat h	arm h	w	d	h	textile fabric yds.	req. leather sq. ft.	weight
<i>Designer(s):</i> Frank Gehry, 1990	93A-GC Cross Check arm chair 	18 1/8"	28 3/4"	28 1/2"	24 7/8"	33 3/8"			12 lbs.
		18 1/8"	28 3/4"	28 1/2"	24 7/8"	33 3/8"	0.8	15	12 lbs.
<i>Award(s):</i> ASID Award, 1992; ROSCOE Award, 1992; ID Magazine Gold Award, 1992; ICFE Award for Excellence, 1992; IBD Award (Silver), 1992; Premium Imperiale Award (Prince Takamatsu World Culture Award), 1992; Time Magazine, Best Design of 1992	93K Seat cushion replacement						0.8	15	
	94L-GC Power Play club chair 	16"	23 1/2"	31 3/8"	30 1/8"	32 7/8"			26 lbs.
		16"	23 1/2"	31 3/8"	30 1/8"	32 7/8"	0.7	14	26 lbs.
	94K Seat cushion replacement						0.7	14	
	94LY-GC Off Side ottoman 			23 1/8"	23 3/8"	8 1/8" - 13 7/8"			6 lbs.
				23 3/8"	23 3/8"	8 1/8" - 13 7/8"	0.7	14	6 lbs.
	94YK Seat cushion replacement						0.7	14	

Order Code

<i>Example:</i>	93A-GC-K-K124/14
93A	Cross Check arm chair
GC	Clear Maple
K	Seat cushion
K1106/8	Spencer, Apricot
<i>Example:</i>	93K-K1106/8
93K	Cross Check chair seat cushion replacement
K1175/3	Obi, Geta

Note:
The Gehry chairs are part of a collection. Please refer to Gehry tables on page 320.

Specify:

1. Pattern number
2. Seat cushion option
3. Textile selection

Seat cushion replacement, specify:

1. Pattern number
2. Textile selection

Ordering Information

Finishes:
Clear Maple (suffix GC)

Seat cushion option:
To specify seat cushion, add "K" to end of pattern number and then list textile/leather pattern number.

Upholstery/COM information:
Prices shown include fabric or leather upholstery. Contact your Knoll representative for colors. Only approved Knoll Textiles and Spinneybeck leathers may be ordered.

Customer's Own Material is available pending approval. For approval requirements, processing instructions and ordering information please see page 18.

Power Play note:
Power Play slats flex individually for added comfort. Recessed screws connect seat and arm.

Off Side note:
Ottoman has one pair of legs that, locked in upright position, create a slanted leg and foot rest (metal fasteners). Legs fold underneath for low foot rest or floor cushion.

Note:
The underside of each piece is embossed with the Knoll logo and Frank Gehry's signature.

Maintenance:
See pages 28-29.

Construction

Frame:
Constructed of hard white maple veneers in 2" wide, 1/32" thick strips. Laminated to 6 to 9-ply thickness with high-bonding urea glue. All wood grains run in same direction for resilience. Thermoset assembly glue provides structural rigidity minimizing the need for metal connectors, while allowing for ergonomic movement and flexibility. Backs on all chairs flex for added comfort.

To maximize tension compression, no assembly glues are used in woven seat: weaves flex in unison for spring-like comfort.

Cushions:
1" thick high resiliency foam for fish-shaped Cross Check cushion. 3/4" thick high resiliency foam for square Power Play and Off Side cushions. Cushions snap-lock underneath chair.

Glides:
Clear plastic with a matte frost finish.

pattern no.	unuphol.	grades	COM								COL				
		A	B	C	D	E	F	G	H	I	U	V	W	X	Y
93A-GC	\$5,858.														
93A-GC-K		6,407.	6,458.	6,507.	6,562.	6,604.	6,635.	6,692.	6,790.	6,865.	7,230.	7,425.	7,812.	7,892.	7,987.
93K-(-)		643.	695.	745.	799.	844.	871.	926.	1,027.	1,102.	1,466.	1,659.	2,047.	2,130.	2,224.
94L-GC	12,088.														
94L-GC-K		12,601.	12,649.	12,689.	12,739.	12,779.	12,806.	12,855.	12,949.	13,018.	13,404.	13,588.	13,958.	14,037.	14,132.
94K-(-)		605.	647.	693.	743.	781.	810.	858.	953.	1,019.	1,409.	1,592.	1,964.	2,042.	2,133.
94LY-GC	3,623.														
94LY-GC-K		4,111.	4,156.	4,197.	4,245.	4,279.	4,306.	4,353.	4,442.	4,509.	4,878.	5,053.	5,408.	5,486.	5,568.
94YK-(-)		578.	618.	662.	709.	745.	773.	821.	911.	976.	1,343.	1,518.	1,874.	1,950.	2,037.

Approved KnollTextiles Grades/Fabrics

A	Alignment Beacon Bocce Chance Common Ground Commuter Cloth Delite Dristi Hourglass Mariner Prep Presto Soliloquy Sonnet Stacks Trophy	E continued Night Life Nonchalant CR Paradigm Pop Prairie Prim # Radiance Ransom Ricochet Roam Rush Hour Soiree Spark Spinoff Nuance Spree Starry Night Summit Sutton Synth Tabloid Utmost Venue Versa Vinyl Westwood Wide Angle Zephyr Zipline	C continued Earthwork Echo Empire Stripe Enmesh Entourage Fibra Greenwich Hudson Hula Hoop Kora CR Lagos Legend CR Lore CR Magnolia Metro Milestone Moto CR Noble Palisade Panache CR Quark Regard CR Roundtrip Sequin CR Sinclair Smart Spot On Star Struck Stepping Stones	C continued Swing Tower Grid Transition Treble CR Vibe Zari CR D Compass CR Coterie Eclat Weave Hologram Island Masquerade Menagerie Origins Satellite Satin Chisel Tara Tilden Theory Woodland Zoom E Highland Ikat Stripe Ikat Square Kampala Katazome Kimono Luberon Mamba Marquee Sherman Shima Tryst
B	Abacus Argyle Bank Shot Belize Betwixt Bistro Boundary Cameo Chroma Chronicle Close Knit Digit Dovetail Ferry Forza Gala II Grande Grandview Holbrook Journey Keaton Knoll Felt Knoll Hopsack Ludlow Lyric Mini Stitch			





Spinneybeck Leather

U	Vicenza Volo	V	Capri Cervo Copenhagen Cordovan Distressed Lucca Marissa Prima Riva
V	Acqua Andes Embossed Tipped España Velluto Pelle	W	Alaska Amazon Antique Arizona Forte Lucente Sabrina
X	Ducale Ducale Velour		

Check with your KnollTextiles or Spinneybeck Representative for changes or additions.

Markus Jehs and Jürgen Laub

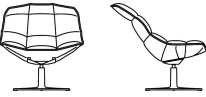
Jehs+Laub Lounge Collection, pedestal base

	description	seat h	w	d	h	weight	type	textile fabric yds.	req. leather sq. ft.
<i>Designer(s):</i> Markus Jehs and Jürgen Laub, 2008	JL1-P Jehs+Laub Lounge chair, fixed back, pedestal base	15"	33 1/4"	30 1/2"	38 1/2"	48 lbs.		3.1	50
									
	JL1-PLT Jehs+Laub Lounge chair, fixed back, pedestal base, contrast leather welt option	15"	33 1/4"	30 1/2"	38 1/2"	48 lbs.	uphol.	3.1	50
							welt		4
	JL2-P Jehs+Laub Lounge chair, articulating back, pedestal base	15"	33 1/4"	30 1/2"	38 1/2"	47 lbs.		3.1	50
									
	JL2-PLT Jehs+Laub Lounge chair, articulating back, pedestal base, contrast leather welt option	15"	33 1/4"	30 1/2"	38 1/2"	47 lbs.	uphol.	3.1	50
							welt		4
	JL3-P Jehs+Laub Ottoman, pedestal base		31"	22 1/2"	17 1/4"	27 lbs.		1.2	20
									
	JL3-PLT Jehs+Laub Ottoman, pedestal base, contrast leather welt option		31"	22 1/2"	17 1/4"	27 lbs.	uphol.	1.2	20
							welt		3

Order Code

<i>Example:</i>	JL2-PLT-AP-K1080/8-VO939
JL2	Jehs+Laub Lounge chair, articulating back
PLT	Pedestal base with contrast leather trim
AP	Polished Aluminum
K1080/8	Rivington, Parchment
VO939	Volo, Talc

Ordering Information

Base finishes:
Polished Aluminum (suffix AP)
Textured Black paint (suffix TB)

Upholstery/COM information:
Prices shown include fabric or leather upholstery. Contact your Knoll representative for colors. Only approved KnollTextiles and Spinneybeck leathers may be ordered.

Customer's Own Material is available pending approval. For approval requirements, processing instructions and ordering information please see page 18.

Maintenance:
See pages 28-29.

Note:
The KnollStudio logo and signature of Markus Jehs and Jürgen Laub are located on the underside of the chair and ottoman.

The Jehs+Laub Lounge Collection with pedestal base is Greenguard certified.

Construction

Shell:
Molded and reinforced urethane.

Base:
Pedestal base is available with polished aluminum finish and wire base is available with polished chrome finish, both bases are also available with textured black paint finish.

Upholstery:
Polyurethane foam with polyester-fiber backing. Hidden seam tufting eliminates the need for traditional pulls or buttons. A perimeter welt is standard on both chair and ottoman and is available as a self welt (same material) or as a contrasting leather welt. Please specify pattern number with LT suffix, for contrasting welt, and add appropriate leather upcharge for total list price of the piece. Leather welt option is available on textile and leather upholstery.

Specify:

1. Pattern number
2. Return to center mechanism, option
3. Base finish selection
4. Textile selection
5. Contrast leather trim selection, upcharge applies

pattern no.	grades A	COM B	C	D	E	F	G	H	I	COL U	V	W	X	Y
JL1-P-()-()-()	\$4,416.	\$4,490.	\$4,559.	\$4,636.	\$4,700.	\$4,745.	\$4,823.	\$4,972.	\$5,081.	\$6,234.	\$6,471.	\$6,955.	\$7,053.	\$7,171.
JL1-PLT-()-()-()	4,416.	4,490.	4,559.	4,636.	4,700.	4,745.	4,823.	4,972.	5,081.	6,234.	6,471.	6,955.	7,053.	7,171.
upchg, welt										755.	876.	1,115.	1,167.	1,225.
JL2-P-()-()-()	5,376.	5,450.	5,520.	5,597.	5,660.	5,706.	5,786.	5,933.	6,041.	7,438.	7,676.	8,159.	8,259.	8,376.
JL2-PLT-()-()-()	5,376.	5,450.	5,520.	5,597.	5,660.	5,706.	5,786.	5,933.	6,041.	7,438.	7,676.	8,159.	8,259.	8,376.
upchg, welt										755.	876.	1,115.	1,167.	1,225.
JL3-P-()-()-()	2,575.	2,604.	2,630.	2,659.	2,685.	2,703.	2,733.	2,790.	2,834.	3,057.	3,151.	3,344.	3,386.	3,432.
JL3-PLT-()-()-()	2,575.	2,604.	2,630.	2,659.	2,685.	2,703.	2,733.	2,790.	2,834.	3,057.	3,151.	3,344.	3,386.	3,432.
upchg, welt										613.	733.	974.	1,025.	1,084.

Approved KnollTextiles Grades/Fabrics

Spinneybeck Leather

Return to center mechanism:

Optional return to center mechanism allows for 360° swivel movement and returns to a center position when not engaged.

To specify return to center mechanism, add suffix RC following the parent pattern number.

Glides:

Nylon glides, natural.

Control:

360° swivel mechanism.

- | | | | | | | | | |
|--|--|--|-----------------------|------------------------------|--|---|--|---|
| A
Analogy
Common Ground
Delite
Dristi
Hourglass
Mariner
Presto
Sonnet | B cont.
Ransom
Ricochet
Spark
Starry Night
Summit
Synth
Venue
Vinyl
Westwood | C
Atlas
Bank Shot ♣
Cameo
Chroma
Ferry
Forza
Journey
Keaton
Knoll Felt ♣
Knoll Hopsack ♣
Ludlow
Nonchalant CR
Pop
Prairie | D
Satellite | E
Highland
Whip | F
Atelier
Calais Cotton
Velvet
Coco
Cornaro
Rivington
Soon
Tweed Frieze | G
Haze
Kingston
Melange
Ultrasuede | H
Arno ♣
Magritte
Rosemond | I
Gates
Knoll Velvet
Ravello
Tudor |
|--|--|--|-----------------------|------------------------------|--|---|--|---|

- | | | | | |
|---------------------------------|---|--|---------------------------|---|
| U
Vicenza ♣
Volo ♣ | V
Acqua ♣
Andes ♣
Embossed Tipped
España ♣
Maremma ♣
Velluto Pelle ♣ | W
Alaska ♣
Antique ♣
Arizona ♣
Forte ♣
Sabrina ♣ | X
Ducale Velour | Y
Capri ♣
Cervo ♣
Copenhagen ♣
Cordovan
Distressed ♣
Marissa ♣
Prima ♣
Riva ♣
Saddle ♣
Torello |
|---------------------------------|---|--|---------------------------|---|

Check with your KnollTextiles or Spinneybeck Representative for changes or additions.

Markus Jehs and Jürgen Laub

Jehs+Laub Lounge Collection, wire base

Designer(s):
Markus Jehs and Jürgen Laub,
2008



description	seat h	w	d	h	weight	type	textile fabric yds.	req. leather sq. ft.
JL1-W Jehs+Laub Lounge chair, fixed back, wire base	14 1/2"	33 1/4"	30 1/2"	38"	43 lbs.		3.1	50
JL1-WLT Jehs+Laub Lounge chair, fixed back, wire base, contrast leather welt option	14 1/2"	33 1/4"	30 1/2"	38"	43 lbs.	uphol. welt	3.1	50 4
JL2-W Jehs+Laub Lounge chair, articulating back, wire base	14 1/2"	33 1/4"	30 1/2"	38"	42 lbs.		3.1	50
JL2-WLT Jehs+Laub Lounge chair, articulating back, wire base, contrast leather welt option	14 1/2"	33 1/4"	30 1/2"	38"	42 lbs.	uphol. welt	3.1	50 4
JL3-W Jehs+Laub Ottoman, wire base		31"	22 1/2"	16 3/4"	22 lbs.		1.2	20
JL3-WLT Jehs+Laub Ottoman, wire base, contrast leather welt option		31"	22 1/2"	16 3/4"	22 lbs.	uphol. welt	1.2	20 3



Order Code

Example: **JL1-W-TB-CO2206**

JL1	Jehs+Laub Lounge chair, fixed back
W	Wire base
TB	Textured Black
CO2206	Copenhagen, Amaliehaven

Specify:

1. Pattern number
2. Base finish selection
3. Textile selection
4. Contrast leather trim selection, upcharge applies

Ordering Information

Base finishes:
Polished Chrome (suffix C)
Textured Black paint (suffix TB)

Upholstery/COM information:
Prices shown include fabric or leather upholstery. Contact your Knoll representative for colors. Only approved KnollTextiles and Spinneybeck leathers may be ordered.

Customer's Own Material is available pending approval. For approval requirements, processing instructions and ordering information please see page 18.

Maintenance:
See pages 28-29.

Note:
The KnollStudio logo and signature of Markus Jehs and Jürgen Laub are located on the underside of the chair and ottoman.

The Jehs+Laub Lounge Collection with wire base is Greenguard certified.

Construction

Shell:
Molded and reinforced urethane.

Base:
Pedestal base is available with polished aluminum finish and wire base is available with polished chrome finish, both bases are also available with textured black paint finish.

Upholstery:
Polyurethane foam with polyester-fiber backing. Hidden seam tufting eliminates the need for traditional pulls or buttons. A perimeter welt is standard on both chair and ottoman and is available as a self welt (same material) or as a contrasting leather welt. Please specify pattern number with LT suffix, for contrasting welt, and add appropriate leather upcharge for total list price of the piece. Leather welt option is available on textile and leather upholstery.

Glides:
Nylon glides, natural.

pattern no.	grades A	COM B	C	D	E	F	G	H	I	COL U	V	W	X	Y
JL1-W-(-)(-)	\$4,416.	\$4,490.	\$4,559.	\$4,636.	\$4,700.	\$4,745.	\$4,823.	\$4,972.	\$5,081.	\$6,234.	\$6,471.	\$6,955.	\$7,053.	\$7,171.

JL1-WLT-(-)(-)(-)	4,416.	4,490.	4,559.	4,636.	4,700.	4,745.	4,823.	4,972.	5,081.	6,234.	6,471.	6,955.	7,053.	7,171.
upchg, welt										755.	876.	1,115.	1,167.	1,225.

JL2-W-(-)(-)	5,376.	5,450.	5,520.	5,597.	5,660.	5,706.	5,786.	5,933.	6,041.	7,438.	7,676.	8,159.	8,259.	8,376.
---------------------	--------	--------	--------	--------	--------	--------	--------	--------	--------	--------	--------	--------	--------	--------

JL2-WLT-(-)(-)(-)	5,376.	5,450.	5,520.	5,597.	5,660.	5,706.	5,786.	5,933.	6,041.	7,438.	7,676.	8,159.	8,259.	8,376.
upchg, welt										755.	876.	1,115.	1,167.	1,225.

JL3-W-(-)(-)	2,575.	2,604.	2,630.	2,659.	2,685.	2,703.	2,733.	2,790.	2,834.	3,057.	3,151.	3,344.	3,386.	3,432.
---------------------	--------	--------	--------	--------	--------	--------	--------	--------	--------	--------	--------	--------	--------	--------

JL3-WLT-(-)(-)(-)	2,575.	2,604.	2,630.	2,659.	2,685.	2,703.	2,733.	2,790.	2,834.	3,057.	3,151.	3,344.	3,386.	3,432.
upchg, welt										613.	733.	974.	1,025.	1,084.

Approved KnollTextiles Grades/Fabrics

Spinneybeck Leather





- A**
Analogy
Common Ground
Delite
Dristi
Hourglass
Mariner
Presto
Sonnet
- B**
Bank Shot #
Cameo
Chroma
Ferry
Forza
Journey
Keaton
Knoll Felt #
Knoll Hopsack #
Ludlow
Nonchalant CR
Pop
Prairie
- C**
Atlas
Biota
Circa
Classic Boucle #
Enmesh
Palisade
Regard
Sahara
Sequin CR
Spot On
Star Struck
Swing
Transition
Vibe
- D**
Ransom
Ricochet
Spark
Starry Night
Summit
Synth
Venue
Vinyl
Westwood
- E**
Highland
Whip
- F**
Atelier
Calais Cotton
Velvet
Coco
Cornaro
Rivington
Soon
Tweed Frieze
- G**
Satellite
- H**
Arno #
Magritte
Rosemond
- I**
Gates
Knoll Velvet
Ravello
Tudor

- U**
Vicenza #
Volo #
- V**
Acqua #
Andes #
Embossed Tipped
España #
Maremma #
Velluto Pelle #
- W**
Alaska #
Antique #
Arizona #
Forte #
Sabrina #
- X**
Ducale Velour
- Y**
Capri #
Cervo #
Copenhagen #
Cordovan
Distressed #
Marissa #
Prima #
Riva #
Saddle #
Torello

Check with your KnollTextiles or Spinneybeck Representative for changes or additions.

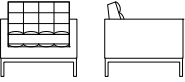
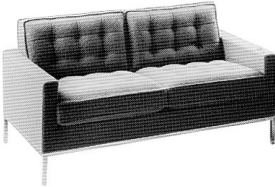
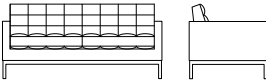
Florence Knoll

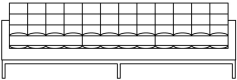
Lounge Seating

	description	seat h	arm h	w	d	h	textile fabric yds.	req. leather sq. ft.	weight
<i>Designer(s):</i> Florence Knoll, 1954	1205S1 Lounge chair 	17 1/2"	23 1/2"	32 1/4"	32 1/4"	31 1/4"	6.75	97	70 lbs.
		17 1/2"	23 1/2"	32 1/4"	32 1/4"	31 1/4"	6.75	97	70 lbs.
	1205S2 Settee 	17 1/2"	23 1/2"	62 1/2"	32 1/4"	31 1/4"	11.8	145	101 lbs.
		17 1/2"	23 1/2"	62 1/2"	32 1/4"	31 1/4"	11.8	145	101 lbs.
	1205S3 Sofa 	17 1/2"	23 1/2"	90 1/2"	32 1/4"	31 1/4"	15.7	193	166 lbs.
		17 1/2"	23 1/2"	90 1/2"	32 1/4"	31 1/4"	15.7	193	166 lbs.
	2530Y2C Two Seater Bench 			36 1/4"	19 1/2"	16 3/4"	1.6	20	29 lbs.
	2530Y3C Three Seater Bench 			60 1/4"	19 1/2"	16 3/4"	2.5	32	47 lbs.

Order Code

<i>Example:</i>	1205-CO-S3-K349/4
1205	Florence Knoll lounge
CO	Satin Chrome
S3	Sofa
K349/4	Alignment, Paprika

Note:
Florence Knoll lounge seating is part of a collection. Please refer to Florence Knoll executive collection, conference and low tables beginning on page 324.

Specify:

1. Pattern number
2. Base finish selection (chair, settee and sofa only)
3. Textile selection

Ordering Information

Base finish options:
Polished Chrome (suffix C)
Satin Chrome (suffix CO) Not available on bench

Upholstery/COM information:
Prices shown include fabric or leather upholstery. Contact your Knoll representative for colors. Only approved KnollTextiles and Spinneybeck leathers may be ordered.

Customer's Own Material is available pending approval. For approval requirements, processing instructions and ordering information please see page 18.

Note:
Designer signature and KnollStudio logo are stamped into the base of the frame.

Cal 133 Fire Code:
The Florence Knoll Lounge collection complies with the California Technical Bulletin 133 standard if upholstered in Cal 133 approved upholstery. Specify suffix -C at end of pattern number and suffix -133 at end of textile selection. Upcharge applies, see page 18.

Maintenance:
See pages 28-29.

Note:
The Florence Knoll Lounge Collection is Greenguard certified.

Construction

Chair, Settee and Sofa:
Inner frame solid wood. Exposed metal frame and legs heavy gauge tubular steel in polished or satin chrome finish.

Bench:
Upholstered seat attached to exposed metal frame. Heavy gauge steel in a polished chrome finish. Seat cushion is permanently attached to frame. Large bench consists of 2 separate 30" cushions. Frame only available in polished chrome.

Upholstery:
Seat suspension with No-Sag springs. Arm, seat and back cushions variable density foam. Seat and back covering is fully welted and tufted. Pieces upholstered in leather have matching buttons, pieces upholstered in fabric do not have buttons.

Glides:
Bench and lounge collection have chrome-plated adjustable glides used for levelling.

pattern no.	grades													
	A	B	C	D	E	F	G	H	I	U	V	W	X	Y
1205-C-S1	\$7,109.	\$7,275.	\$7,431.	\$7,606.	\$7,746.	\$7,847.	\$8,022.	\$8,353.	\$8,597.	\$10,393.	\$11,033.	\$12,341.	\$12,613.	\$12,930.
1205-CO-S1	7,246.	7,414.	7,569.	7,744.	7,885.	7,985.	8,160.	8,490.	8,736.	10,531.	11,172.	12,478.	12,752.	13,068.
1205-C-S2	11,360.	11,617.	11,867.	12,135.	12,357.	12,518.	12,791.	13,306.	13,689.	16,175.	17,140.	19,094.	19,499.	19,974.
1205-CO-S2	11,569.	11,825.	12,076.	12,346.	12,567.	12,727.	12,999.	13,515.	13,898.	16,386.	17,349.	19,303.	19,707.	20,183.
1205-C-S3	15,716.	16,045.	16,358.	16,698.	16,982.	17,186.	17,531.	18,182.	18,671.	22,269.	23,549.	26,153.	26,691.	27,323.
1205-CO-S3	15,996.	16,327.	16,638.	16,982.	17,263.	17,466.	17,812.	18,464.	18,952.	22,551.	23,829.	26,435.	26,974.	27,605.
2530Y2C	3,489.	3,535.	3,576.	3,626.	3,666.	3,694.	3,744.	3,834.	3,902.	4,114.	4,278.	4,609.	4,681.	4,761.
2530Y3C	5,764.	5,847.	5,927.	6,014.	6,083.	6,133.	6,221.	6,387.	6,505.	6,748.	7,009.	7,543.	7,653.	7,787.

Approved KnollTextiles Grades/Fabrics

A	Alignment ‡	Beacon	Bocce	Chance	Common Ground	Commuter Cloth	Cotton Duck	Delite	Dristi	Hourglass	Mariner	Metaphor	Monarch ‡	Presto ‡ **	Sonnet	Trophy
B	Abacus ‡	Bank Shot	Cameo	Chroma	Digit	Ferry										
C	Atlas	Autobahn	Biota ‡	Circa	Classic Boucle	Entourage	Greenwich	Hula Hoop	Lagos	Lore CR	Palisade	Sahara	Sequin CR			
D	Spot On	Stepping Stones	Swing **	Tilden	Transition ‡											
E	Highland	Katazome	Luberon	Mamba	Whip											
F	Atelier	Calais Cotton	Velvet	Coco **	Cornaro **	Eclipse	Rivington	Soon	Topography							
G	Haze	Kingston	Melange	Spencer	Ultrasuede ‡											
H	Arno	Gezelle	Magritte	Rosemond												
I	Cato	Dynamic	Gates	Knoll Velvet	Ravello **	Tudor	Vermeer									

Spinneybeck Leather













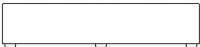

U	Vicenza ‡	Volo ‡
V	Acqua ‡	Andes ‡
W	Alaska ‡	Amazon ‡
X	Antique ‡	Arizona ‡
Y	Capri ‡	Cervo
	Copenhagen ‡	Cordovan ‡
	Distressed ‡	Marissa ‡
	Embossed Tipped	España ‡
	Esperanza ‡	Velluto Pelle ‡
	Prima ‡	Riva ‡
	Saddle ‡	

‡ Available for Cal 133 upholstery.
 * Will be produced with matching buttons rather than tufted
 ** Fabric will be railroaded

Check with your KnollTextiles or Spinneybeck Representative for changes or additions.

Knoll Design

k.™ lounge Collection

	description	seat h	w	d	h	textile fabric yds.
<p>Designer(s): Knoll Design, 2014</p>   	<p>KL1 Bench, two seat</p>   	17 1/4"	52"	21 1/2"	17 1/4"	4
	<p>KL2 Bench, three seat</p>   	17 1/4"	78"	21 1/2"	17 1/4"	7
	<p>KL3 Bench, 48" inside radius, 60°</p>   	17 1/4"	38 3/4"	38 3/4"	17 1/4"	3.25
	<p>KL4 Bench with back, single seat</p>   	17 1/4"	26"	28 3/4"	26"	3.5

Order Code

Example:	KL1-KLF01
KL1	Bench, two seat
KLF01	k.™ lounge textile, Green Tea

Specify:

1. Pattern number
2. Textile selection

Ordering Information

Upholstery/COM information:
Prices shown include fabric upholstery. Contact your Knoll representative for colors. Only approved KnollTextiles may be ordered.

Customer's Own Material is available pending approval. For approval requirements, processing instructions and ordering information please see page 422.

Cal 133 Fire Code #:
The k.lounge Collection complies with the California Technical Bulletin 133 standard if upholstered in Cal 133 approved upholstery. Specify suffix -C at end of pattern number. Upcharge applies, see page 0

Split upholstery option:
The seat and back sections of the KL4, KL5, KL6, KL7, and KL8 may be specified with split upholstery for **KnollTextiles ONLY**. Indicate B before selected back upholstery, followed by selected seat upholstery. Price equals the higher upholstery grade.

Note:
Split upholstery with base grade textiles or a combination of KnollTextiles and base grade textiles must be requested through Custom Product Development.

COM split fabric requirements:

KL4 seat:	2 yards
KL4 back:	1.75 yards
KL5 seat:	4 yards
KL5 back:	2.75 yards
KL6 seat:	4.75 yards
KL6 back:	3.5 yards
KL7 seat:	3 yards
KL7 back:	4 yards
KL8 seat:	3.5 yards
KL8 back:	2.5 yards

Construction

Frame:
Constructed from zero-emission plywood frames and joined by CNC finger joints. Joinery is glued and reinforced with corner blocks and fasteners.

Upholstery:
High resilience, multi-density urethane foam. Exceeds Cal 117 standards, and meets British Standards.

Glides:
Large footprint, non-marking nylon leveling glides, standard on all k.™ lounge except stool. Stool has flat, non-marking teflon glides at bottom edge of frame.

Ganging:
Four no-tool nylon ganging brackets standard on all k.™ lounge except stool and pouf.

pattern no.	k.™ lounge fabric	A	COM B	C	D	E	F	G	H	I
KL1(-)	\$1,380.	\$1,651.	\$1,700.	\$1,754.	\$1,819.	\$1,908.	\$1,960.	\$2,052.	\$2,112.	\$2,293.
KL2(-)	1,864.	2,173.	2,235.	2,304.	2,387.	2,501.	2,567.	2,683.	2,760.	2,991.
KL3(-)	1,288.	1,564.	1,612.	1,667.	1,731.	1,820.	1,873.	1,964.	2,024.	2,205.
KL4(-)	1,689.	2,021.	2,081.	2,148.	2,227.	2,336.	2,401.	2,512.	2,586.	2,809.

Approved k.™ lounge Fabric

Fabric, Base Grade:
 Green Tea (suffix KLF01) ‡
 Heirloom Tomato (suffix KLF02) ‡
 Blue Moon (suffix KLF03) ‡
 Earl Grey (suffix KLF04) ‡
 Chocolate Stout (suffix KLF05) ‡
 Black Tea (suffix KLF06) ‡

Approved KnollTextiles Grades/Fabrics

<p>A Delite ‡ Hourglass Mariner Presto ‡ Sonnet</p> <p>B Bank Shot Cameo Chroma Chronicle Gala II Holbrook * Journey Keaton Knoll Felt Knoll Hopsack</p>	<p>B continued Paradigm Prairie Ricochet ‡ Rush Hour Sutton ‡ Tabloid * Utmost ‡ Venue ‡ Westwood Wide Angle *</p>	<p>C Atlas Classic Boucle Dahlia CR Durand Lagos Lore CR Noble Roundtrip * Sinclair * Spot On Star Struck Swing</p> <p>D Tara * Theory *</p>	<p>E Shima Whip</p>	<p>F Atelier Rivington</p> <p>G Haze Melange Ultrasuede</p> <p>I Cato</p>
---	---	--	--	--

‡ Approved for Cal 133 upholstery
 *Not approved on KL3, KL7, KL8, and KL11

Check with your KnollTextiles Representative for changes or additions.

Knoll Design

k.™ lounge Collection

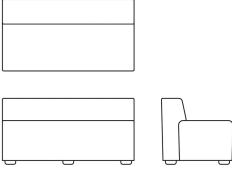
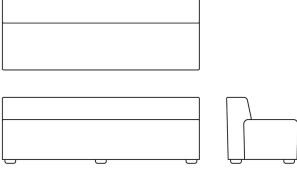
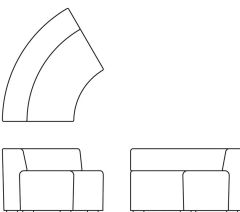
	description	seat h	w	d	h	textile fabric yds.
<p>Designer(s): Knoll Design, 2014</p> 	<p>KL5 Bench with back, two seat</p> 	17 1/4"	52"	28 1/4"	26"	6
	<p>KL6 Bench with back, three seat</p> 	17 1/4"	78"	28 1/4"	26"	8
	<p>KL7 60° Curved bench with back, inside radius</p> 	17 1/4"	44 1/2"	44 1/2"	26"	5.5

Order Code

<i>Example:</i>	KL1-KLF01
KL1	Bench, two seat
KLF01	k.™ lounge textile, Green Tea

Specify:

1. Pattern number
2. Textile selection

Ordering Information

Upholstery/COM information:
Prices shown include fabric upholstery. Contact your Knoll representative for colors. Only approved KnollTextiles may be ordered.

Customer's Own Material is available pending approval. For approval requirements, processing instructions and ordering information please see page 422.

Cal 133 Fire Code #:
The k.lounge Collection complies with the California Technical Bulletin 133 standard if upholstered in Cal 133 approved upholstery. Specify suffix -C at end of pattern number. Upcharge applies, see page 0

Split upholstery option:
The seat and back sections of the KL4, KL5, KL6, KL7, and KL8 may be specified with split upholstery for **KnollTextiles ONLY**. Indicate B before selected back upholstery, followed by selected seat upholstery. Price equals the higher upholstery grade.

Note:
Split upholstery with base grade textiles or a combination of KnollTextiles and base grade textiles must be requested through Custom Product Development.

COM split fabric requirements:

KL4 seat:	2 yards
KL4 back:	1.75 yards
KL5 seat:	4 yards
KL5 back:	2.75 yards
KL6 seat:	4.75 yards
KL6 back:	3.5 yards
KL7 seat:	3 yards
KL7 back:	4 yards
KL8 seat:	3.5 yards
KL8 back:	2.5 yards

Construction

Frame:
Constructed from zero-emission plywood frames and joined by CNC finger joints. Joinery is glued and reinforced with corner blocks and fasteners.

Upholstery:
High resilience, multi-density urethane foam. Exceeds Cal 117 standards, and meets British Standards.

Glides:
Large footprint, non-marking nylon leveling glides, standard on all k.™ lounge except stool. Stool has flat, non-marking teflon glides at bottom edge of frame.

Ganging:
Four no-tool nylon ganging brackets standard on all k.™ lounge except stool and pouf.

pattern no.	k.™ lounge fabric	A	COM B	C	D	E	F	G	H	I
KL5(-)	\$2,256.	\$2,796.	\$2,894.	\$3,003.	\$3,132.	\$3,311.	\$3,415.	\$3,598.	\$3,719.	\$4,082.

KL6(-)	3,054.	3,736.	3,857.	3,993.	4,155.	4,379.	4,509.	4,737.	4,888.	5,342.
---------------	--------	--------	--------	--------	--------	--------	--------	--------	--------	--------

KL7(-)	2,034.	2,454.	2,539.	2,633.	2,745.	2,899.	2,989.	3,147.	3,252.	3,565.
---------------	--------	--------	--------	--------	--------	--------	--------	--------	--------	--------

Approved k.™ lounge Fabric

Fabric, Base Grade:
 Green Tea (suffix KLF01) ‡
 Heirloom Tomato (suffix KLF02) ‡
 Blue Moon (suffix KLF03) ‡
 Earl Grey (suffix KLF04) ‡
 Chocolate Stout (suffix KLF05) ‡
 Black Tea (suffix KLF06) ‡

Approved KnollTextiles Grades/Fabrics



A Delite ‡ Hourglass Mariner Presto ‡ Sonnet	B continued Paradigm Prairie Ricochet ‡ Rush Hour Sutton ‡ Tabloid * Utmost ‡ Venue ‡ Westwood Wide Angle *	C Atlas Classic Boucle Dahlia CR Durand Lagos Lore CR Noble Roundtrip * Sinclair * Spot On Star Struck Swing	E Shima Whip	F Atelier Rivington	G Haze Melange Ultrasuede	I Cato
B Bank Shot Cameo Chroma Chronicle Gala II Holbrook * Journey Keaton Knoll Felt Knoll Hopsack		D Tara * Theory *				

‡ Approved for Cal 133 upholstery
 *Not approved on KL3, KL7, KL8, and KL11

Check with your KnollTextiles Representative for changes or additions.

Knoll Design

k.™ lounge Collection

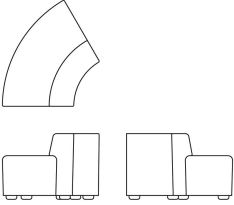
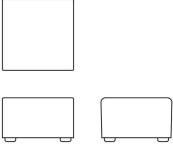
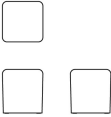
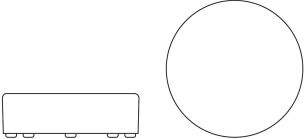
	description	seat h	w	d	h	textile fabric yds.
<p>Designer(s): Knoll Design, 2014</p>   	<p>KL8 60° Curved bench with back, outside radius</p> 	17 1/4"	42"	42"	26"	4.5
	<p>KL9 Ottoman</p> 	17 1/4"	28 1/4"	28"	17 1/4"	2.75
	<p>KL10 Stool</p> 	17 1/4"	16"	16"	17 1/4"	1.75
	<p>KL11 Pouf</p> 	17 1/4"	50"	50"	17 1/4"	4.75

Order Code

<i>Example:</i>	KL1-KLF01
KL1	Bench, two seat
KLF01	k.™ lounge textile, Green Tea

Specify:

1. Pattern number
2. Textile selection

Ordering Information

Upholstery/COM information:
Prices shown include fabric upholstery. Contact your Knoll representative for colors. Only approved KnollTextiles may be ordered.

Customer's Own Material is available pending approval. For approval requirements, processing instructions and ordering information please see page 422.

Cal 133 Fire Code #:
The k.lounge Collection complies with the California Technical Bulletin 133 standard if upholstered in Cal 133 approved upholstery. Specify suffix -C at end of pattern number. Upcharge applies, see page 0

Split upholstery option:
The seat and back sections of the KL4, KL5, KL6, KL7, and KL8 may be specified with split upholstery for **KnollTextiles ONLY**. Indicate B before selected back upholstery, followed by selected seat upholstery. Price equals the higher upholstery grade.

Note:
Split upholstery with base grade textiles or a combination of KnollTextiles and base grade textiles must be requested through Custom Product Development.

COM split fabric requirements:

KL4 seat: 2 yards
KL4 back: 1.75 yards
KL5 seat: 4 yards
KL5 back: 2.75 yards
KL6 seat: 4.75 yards
KL6 back: 3.5 yards
KL7 seat: 3 yards
KL7 back: 4 yards
KL8 seat: 3.5 yards
KL8 back: 2.5 yards

Construction

Frame:
Constructed from zero-emission plywood frames and joined by CNC finger joints. Joinery is glued and reinforced with corner blocks and fasteners.

Upholstery:
High resilience, multi-density urethane foam. Exceeds Cal 117 standards, and meets British Standards.

Glides:
Large footprint, non-marking nylon leveling glides, standard on all k.™ lounge except stool. Stool has flat, non-marking teflon glides at bottom edge of frame.

Ganging:
Four no-tool nylon ganging brackets standard on all k.™ lounge except stool and pouf.

pattern no.	k.™ lounge fabric	A	COM B	C	D	E	F	G	H	I
KL8-()	\$2,034.	\$2,454.	\$2,539.	\$2,633.	\$2,745.	\$2,899.	\$2,989.	\$3,147.	\$3,252.	\$3,565.
KL9-()	1,025.	1,213.	1,251.	1,294.	1,343.	1,412.	1,453.	1,523.	1,570.	1,710.
KL10-()	613.	758.	783.	810.	843.	887.	914.	959.	989.	1,079.
KL11-()	2,245.	2,646.	2,719.	2,801.	2,897.	3,032.	3,111.	3,247.	3,338.	3,610.

Approved k.™ lounge Fabric

Fabric, Base Grade:
 Green Tea (suffix KLF01) ‡
 Heirloom Tomato (suffix KLF02) ‡
 Blue Moon (suffix KLF03) ‡
 Earl Grey (suffix KLF04) ‡
 Chocolate Stout (suffix KLF05) ‡
 Black Tea (suffix KLF06) ‡

Approved KnollTextiles Grades/Fabrics

<p>A Delite ‡ Hourglass Mariner Presto ‡ Sonnet</p> <p>B Bank Shot Cameo Chroma Chronicle Gala II Holbrook * Journey Keaton Knoll Felt Knoll Hopsack</p>	<p>B continued Paradigm Prairie Ricochet ‡ Rush Hour Sutton ‡ Tabloid * Utmost ‡ Venue ‡ Westwood Wide Angle *</p>	<p>C Atlas Classic Boucle Dahlia CR Durand Lagos Lore CR Noble Roundtrip * Sinclair * Spot On Star Struck Swing</p> <p>D Tara * Theory *</p>	<p>E Shima Whip</p>	<p>F Atelier Rivington</p> <p>G Haze Melange Ultrasuede</p> <p>I Cato</p>
---	---	--	--	--







‡ Approved for Cal 133 upholstery
 *Not approved on KL3, KL7, KL8, and KL11

Check with your KnollTextiles Representative for changes or additions.

KnollStudio

Throw Pillows



description	w	d	textile fabric yds.	type
KSP1 Lumbar pillow 	20"	10.5"	0.4	same upholstery
KSP1S Lumbar pillow 	20"	10.5"	0.4	combination upholstery
KSP2 Throw pillow 	16"	16"	0.4	same upholstery
KSP2S Throw pillow 	16"	16"	0.4	combination upholstery
KSP3 Large throw pillow 	20"	20"	0.7	same upholstery
KSP3S Large throw pillow 	20"	20"	0.7	combination upholstery

Order Code

<i>Example:</i>	KSP1-K1174/6
KSP1	Lumbar pillow, same upholstery
K1174/6	Kimono, Sakura
<i>Example:</i>	KSP3S-K1155/6-K1021/2
KSP3S	Large throw pillow, combination upholstery
K1155/6	Jaipur, Ginger
K1021/2	Ultrasuede, Sand

Ordering Information

Upholstery/COM information:
Prices shown include fabric upholstery only. Contact your Knoll representative for colors. Only approved KnollTextiles may be ordered.

Customer's Own Material is not approved.

Note:
For pillows with combination upholstery, list price is the highest of the two grades.

Construction

Fill:
Made from 100% recycled polyester.

Tickings:
100% cotton.

Specify:

1. Pattern number
2. Upholstery selection
3. Upholstery selection for split upholstery

pattern no.	A	B	C	D	E	F	G	H	I
KSP1-()	\$174.	\$182.	\$190.	\$199.	\$205.	\$211.	\$219.	\$237.	\$248.
KSP1S-()-()	191.	200.	208.	216.	224.	228.	238.	254.	267.
KSP2-()	218.	227.	236.	243.	250.	255.	266.	281.	294.
KSP2S-()-()	241.	249.	258.	267.	273.	277.	287.	304.	315.
KSP3-()	348.	364.	380.	396.	412.	421.	439.	471.	496.
KSP3S-()-()	384.	402.	416.	434.	448.	459.	475.	507.	533.









Approved KnollTextiles Grades/Fabrics

A	Alignment Beacon Bocce Cat's Cradle Chance Common Ground Commuter Cloth Cotton Duck Delite Dristi Heavy Metal Hourglass Mariner Metaphor Monarch Prep Presto Soliloquy Sonnet Stacks Trophy	B continued Ludlow Mini Stitch Nonchalant CR Paradigm Pogo Pop Prairie Prim Radiance Ransom Ricochet Roam Rush Hour Soiree Spark Spree Starry Night Summit Sutton Synth Tabloid Utmost Venue Versa Westwood Zephyr Zipline	C continued Hudson Hula Hoop Kaleidoscope Kora CR Lagos Lore CR Magnolia Metro Milestone Moto CR Noble Panache CR Quark Regard CR Roundtrip Sahara Sandpiper Sequin CR Sinclair Spot On Star Struck Stepping Stones Swing Tight Rope Tilden Tower Grid Transition Treble CR Vibe Zari CR	D Coterie Eclat Weave Hologram Island Masquerade Menagerie Origins Satellite Satin Chisel Tara Theory Woodland Zoom	E Highland Ikat Square Ikat Stripe Kampala Katazome Kimono Luberon Mamba Marquee Meroe Sherman Shima Tryst Whip	F Atelier Biscayne Calais Cotton Velvet Century Coco Cornaro Glider Intrigue Liberty Mod Plaid Rivington Soon Topography Totem	G Arabella Arber Djenne Gibson Hampshire Haze Kamani Kinabalu Kingston Melange Metallic Gloss Sablon Serendipity Spencer Straie Stripe Ultrasuede Utrillo	H Arno Bavaria Constance Firefly Gezelle Magritte Rosemond	I Aswan Cato Dynamic Gates Diamond Days Digi Velvet Jaipur Ita Knoll Velvet Olema Piper Ravello Rutledge Sandis Tudor Vermeer Walker Worth Zimba
----------	---	--	---	---	--	--	---	--	--

Check with your KnollTextiles
Representative for changes or additions.

Antti Kotilainen

CHIP Chair and Barstool

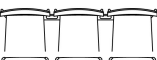
	description	seat h	arm h, max	w	d	h	weight
Designer(s): Antti Kotilainen, 2002 Award(s): Good Design Award, 2002	23C CHIP armless chair 	17 3/4"		20"	19 3/4"	31"	7 lbs.
	23CK CHIP armless chair, seat pad 	17 3/4"		20"	19 3/4"	31"	8 lbs.
 	23A CHIP arm chair 	17 3/4"	26 3/4"	21 1/2"	19 3/4"	31"	10 lbs.
	23AK CHIP arm chair, seat pad 	17 3/4"	26 3/4"	21 1/2"	19 3/4"	31"	10 lbs.
	23CH-C CHIP Barstool, bar height, chrome base 	29 1/2"		19 1/2"	17 1/2"	33 3/4"	10 lbs.
	23DOLLY Dolly for 20 chairs 			23 7/8"	32 1/4"	34 7/8"	24 lbs.
	23GA Ganging mechanism 						

Order Code

<i>Example:</i>	23CK-N-WV-C-D893
23CK-N	Chip armless non-stacking chair
WV	White shell
C	Chrome base
D893	Divina 893 fabric
<i>Example:</i>	23CH-BU-C
23CH	Chip barstool
BU	Blue shell
C	Chrome base

Ordering Information

<i>Shell Finishes:</i>
 Birch (suffix FMB)
Blue (suffix BU)
Black (suffix BL)
Oak (suffix FMO)
Red (suffix RD)
 Grey (suffix SL)
 White (suffix WV)
<i>Frame Finishes:</i>
 Chrome (suffix C)

 **KnollStudio 20-Day Program:**
The Chip armless chair with a chrome base and white, birch or grey shells are available on the 20-day program. For more specific information, please consult pages 30-33.

Maintenance:
See pages 28-29.

Cal 133 Fire Code #:
The Chip chair and Barstool, if unupholstered, passes the Cal 133 standard.

Note:
The CHIP chair and stool are Greenguard certified.

Construction

Chair:
Constructed of melamine covered molded birch on a chrome plated base.

Note: The backrest mounts will always be in the silver grey powder paint, even on a chair with chrome frame.

Seat pad:
CHIP chair with seat pad does not stack. Seat pad is a dacron covered piece of plywood attached to the chair seat. Seat pad is permanently attached to seat by discrete screws not visible from top of chair. Upholstery available in Gabriel fabrics: Event, Fame, and Gaja. Please contact your KnollStudio sales representative for samples.

Specify:

1. Pattern number
2. Shell finish
3. Frame finish
4. Textile selection

pattern no.	unuphol.	seat pad
23C-()-C 	\$803.	
23CK-N-()-C-()		1,295.
23A-()-C	1,153.	
23AK-N-()-C-()		1,693.
23CH-()-C	849.	
23DOLLY	1,683.	
23GA	71.	

Barstool:
Constructed of melamine covered molded birch on a chrome plated base. Foot rest is 11 1/2" from the floor.

Stackability:
Chair
CHIP stacks 12 on the floor. Height of 12 CHIP chairs measures 46" high.

Barstool
CHIP Barstool stacks 6 high on the floor.

Transportation Dolly:
Zinc coated dolly allows CHIP arm and armless chairs to stack 20 high. Height of dolly with 20 CHIP chairs, fully loaded is 63". Empty dollies can be stacked 5 high.

Ganging Mechanism:
The easy to attach and detach mechanism links the back of the chair frames. The mechanism is composed of translucent polypropylene. Can be used for both arm and armless chairs.

Approved Textiles

Event (E):
100% polyester crepe fabric. It is a synthetic fabric suitable for environments with special requirements regarding cleaning.

Fame (F):
A unique woollen upholstery fabric with a wearability of 200,000 Martindale. Extra soft and stretchable with an elegant and vibrant color scale.

Gaja (G):
Non directional crepe weave made from 100% pure New Wool from New Zealand with anti-slip properties.

Please contact your KnollStudio representative for colorways, color codes and samples.



Marc Krusin

Guest Seating Collection

Side Chair with Arms

Designer(s):
Marc Krusin, 2011

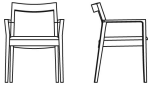

description	seat h	arm h	w	d	h	textile fabric yds.	required leather sq. ft.	weight	finish
MK01A Krusin arm chair 	18 1/2"	24 1/2"	23 1/2"	21 3/4"	30 1/2"	0.8	14.5	14 lbs.	beech finish
	18 1/2"	24 1/2"	23 1/2"	21 3/4"	30 1/2"	0.8	14.5	14 lbs.	ash or oak finish
	18 1/2"	24 1/2"	23 1/2"	21 3/4"	30 1/2"	0.8	14.5	14 lbs.	walnut finish
MK01AU Krusin arm chair, uphol. inset back 	18 1/2"	24 1/2"	23 1/2"	21 3/4"	30 1/2"	0.8	14.5	14 lbs.	beech finish
	18 1/2"	24 1/2"	23 1/2"	21 3/4"	30 1/2"	0.8	14.5	14 lbs.	ash or oak finish
	18 1/2"	24 1/2"	23 1/2"	21 3/4"	30 1/2"	0.8	14.5	14 lbs.	walnut finish
MK01R Seat basket replacement for side chair						0.8	14.5		
MK01RCN Woven rush seat basket replacement for side chair									light kraft

Order Code

<i>Example:</i>	MK01A-BE-K1207/17
MK01A	Krusin arm chair
BE	Ebonized
K1207/17	Knoll Felt, Pewter

Specify:

1. Pattern number
2. Woven rush seat, optional
3. Finish selection
4. Textile selection

Ordering Information:

Ash:

White Ash (suffix A101)

Beech frame stains:

Beech (suffix B311)
Bronzed Cherry (suffix B312A)
Burnt Walnut (suffix B313)
Deep Red Mahogany (suffix B328)
Ebonized (suffix BE)
Light Cherry (suffix B315)
Light Walnut (suffix B411)
Medium Cherry (suffix B319)
Medium Red Mahogany (suffix BR)
Medium Walnut (suffix B323)
Natural Beech (suffix BN)
Warm Brown Walnut (J)

Oak:

Ebonized Oak (suffix OE)
Fumed Oak (suffix OF)
Grey Oak, White Ceruse (suffix OGW)
Grey Oak, Black Ceruse (suffix OGB)
Natural Oak (suffix ON)

Walnut:

American Walnut (suffix AW)

Optional Woven Seat:

An optional woven paper rush seat is available at an upcharge, from grade A pricing, of \$276 for side chairs and \$309 for lounge chairs. Place suffix CN between parent pattern number and wood finish suffix.
Example:MK01A-CN-BE

Upholstery/COM information:

List prices shown include fabric or leather upholstery. Contact your Knoll representative for colors. Only approved KnollTextiles and Spinneybeck leathers may be ordered.

Customer's Own Material is available pending approval. For approval requirements, processing instructions and ordering information please see page 18.

KnollStudio natural wood finishes:

The Krusin Collection of guest seating features a low sheen, Greenguard approved, urethane finish. This finish, available on Ash, Oak, and Walnut delivers the tactility of natural wood while providing a durable matte finish.

Ash and Oak feature a unique staining process that replicate traditional cereused finishes.

KnollStudio Beech wood finishes:

KnollStudio Beech finishes complement a large variety of KnollStudio veneer and Knoll Office veneer finishes. To select correct complementary finish, please refer to KnollStudio Wood Finish Matrix on page 25. If no complementary finish is available, please refer to custom finish policy below.

Custom finishes:

Complementary finishes to any KnollStudio or Knoll Office wood finish are available at no upcharge. To complement non-Knoll wood veneer or lumber finishes, a one-time, non-negotiable net upcharge of \$618 applies. Re-orders are at no upcharge. Please contact your KnollStudio representative, dealer or Customer Service associate for complete custom finish information and Order Code. Minimum order quantity for any custom finish order: 4 chairs.

Certified Wood:

Chairs manufactured using FSC certified hardwoods are available through Custom Product Development. Extended leadtime and upcharge apply.

Maintenance:

See pages 28-29

Note:

The Krusin Collection chairs are Greenguard certified in all wood finishes.

Cal 133 Fire Code #:

The Krusin Side Chairs comply with the California Technical Bulletin 133 standard if upholstered in Cal 133 approved upholstery. Specify suffix -C at end of pattern number and suffix -133 at end of textile selection. Upcharge applies, see page 18.

Construction

Frame:

Select American and European hard wood frames. Dowel and mortise and tenon construction, steam bent top rail. A bent laminate upholstered inset back is available. The back of inset features horizontal grain direction.

Upholstered Seat:

High density, polyurethane foam used in all upholstered areas. Elastic seat belt suspension.

Woven Rush Seats:

A woven natural paper rush seat is available on side and lounge chairs. Not available on chairs with inset back upholstery. Paper rush is a natural, uncoated material.

KnollStudio will not warrant soiled or stained woven seats. A one year warranty will cover woven seats for manufacturer's defects.

Seat basket replacements:

Upholstered and woven seats sit on chair frame. Screws lock basket in place for easy installation or removal.

Finish:

Beech, Catalyzed lacquer protective coating. Hand applied final wax coating. Ash, Oak, and Walnut, urethane protective coating. Hand applied final wax coating.

Glides:

Chairs feature nylon glides.

pattern no.	grades	COM											COL				
	A	B	C	D	E	F	G	H	I	U	V	W	X	Y			
MK01A-()	\$1,098.	\$1,114.	\$1,133.	\$1,154.	\$1,168.	\$1,179.	\$1,199.	\$1,237.	\$1,264.	\$1,467.	\$1,519.	\$1,656.	\$1,684.	\$1,717.			
MK01A-(A101, O)	1,357.	1,374.	1,392.	1,412.	1,428.	1,439.	1,458.	1,496.	1,522.	1,727.	1,778.	1,915.	1,943.	1,977.			
MK01A-(AW)	1,672.	1,688.	1,707.	1,727.	1,742.	1,754.	1,773.	1,811.	1,838.	2,041.	2,093.	2,230.	2,258.	2,291.			
MK01AU-()	1,402.	1,417.	1,437.	1,456.	1,472.	1,483.	1,502.	1,541.	1,567.	1,771.	1,823.	1,959.	1,987.	2,020.			
MK01AU-(A101, O)	1,660.	1,677.	1,695.	1,716.	1,731.	1,742.	1,762.	1,799.	1,826.	2,030.	2,082.	2,219.	2,246.	2,279.			
MK01AU-(AW)	1,976.	1,991.	2,011.	2,030.	2,046.	2,057.	2,076.	2,115.	2,141.	2,344.	2,397.	2,534.	2,561.	2,594.			
MK01R	320.	337.	355.	376.	390.	402.	421.	459.	486.	679.	730.	867.	894.	928.			
MK01RCN	414.	0.	0.	0.	0.	0.	0.	0.	0.	0.	0.	0.	0.	0.			

Approved KnollTextiles Grades/Fabrics

A	Alignment ♣ Analogy Beacon Bocce ♣ Cat's Cradle ♣ Chance Common Ground ♣ Commuter Cloth ♣ Cotton Duck Delite Dristi Foil Rap Gala II Heavy Metal Hourglass Mariner Metaphor Monarch Prep ♣ Presto ♣ Soliloquy Sonnet Stacks ♣ Trophy ♣	B	Abacus ♣ Argyle Backdrop Bank Shot Belize Betwixt Bistro ♣ Boundary ♣ Cameo Chroma ♣ Chronicle Close Knit Digit Digital Tape Dovetail Fast Forward	C	Atlas Autobahn Axiom Baxter Biota ♣ Cairo Charm Circa Classic Boucle Dahlia CR Decade Durand Earthwork ♣ Echo Empire Stripe Enmesh ♣ Entourage ♣ Fable CR * Fibra Greenwich Hudson Hula Hoop Kaleidoscope CR Kora CR Soiree ♣ Spark ♣ Legend CR Lore CR Magnolia Metro Milestone Moto CR Noble Palisade Panache CR Posh Quark Regard CR Roundtrip ♣ Sahara Sandpiper Sequin CR Sinclair Smart	C continued	Spectator ♣ Spot On Star Struck Stepping Stones Swing Tight Rope Tilden * Tower Grid Transition ♣ Treble CR Vibe Zari CR	D	Compass CR Coterie Eclat Weave Hologram In The Loop Island Masquerade Menagerie Origins Satellite Satin Chisel Tara Theory Woodland Zoom	E	Highland Ikat Stripe Ikat Square Kampala Katazome Kimono Luberon Mamba Marquee Sherman Shima Tryst Whip	F	Atelier Biscayne Calais Cotton Velvet Century Coco Cornaro Eclipse Glider Icon Intrigue Liberty Mod Plaid Rivington Soon Topography Totem Tweed Frieze	G	Arabella Arber Djenne Gibson Hampshire * Haze Kamani Kinabalu Kingston Melange Metallic Gloss Sablon Serendipity Spencer Straie Stripe Ultrasuede Utrillo	H	Arno Bavaria Constance Firefly Gezelle Magritte Rosemond	I	Aswan Byron Canaan Cato Cummings Diamond Days Digi Velvet Dynamic Gates Ita Jaipur Knoll Velvet Mepal North Island Olema Piper Ravello Rutledge Sandis Tudor Vermeer Walker Worth Zimba	U	Vicenza ♣ Volo ♣	V	Acqua ♣ Andes ♣ Embossed Tip ♣ España ♣ Hand Tipped Maremma ♣ Velluto Pelle ♣	W	Alaska ♣ Amazon ♣ Antique ♣ Arizona ♣ Derby Forte ♣ Lucente Sabrina ♣	X	Ducale * ♣ Ducale Velour ♣	Y	Capri * ♣ Cervo * ♣ Copenhagen ♣ Cordovan ♣ Distressed ♣ Lucca * Marissa ♣ Portofino Prima ♣ Riva ♣ Saddle Salon ♣ Torello * ♣
----------	---	----------	---	----------	--	--------------------	---	----------	--	----------	---	----------	---	----------	---	----------	--	----------	--	----------	---------------------	----------	---	----------	--	----------	-------------------------------	----------	--

Spinneybeck Leather

U	Vicenza ♣ Volo ♣	V	Acqua ♣ Andes ♣ Embossed Tip ♣ España ♣ Hand Tipped Maremma ♣ Velluto Pelle ♣	W	Alaska ♣ Amazon ♣ Antique ♣ Arizona ♣ Derby Forte ♣ Lucente Sabrina ♣	X	Ducale * ♣ Ducale Velour ♣	Y	Capri * ♣ Cervo * ♣ Copenhagen ♣ Cordovan ♣ Distressed ♣ Lucca * Marissa ♣ Portofino Prima ♣ Riva ♣ Saddle Salon ♣ Torello * ♣
----------	---------------------	----------	---	----------	--	----------	-------------------------------	----------	--

*Not approved for inset back.

Check with your KnollTextiles or Spinneybeck Representative for changes or additions.



Marc Krusin

Guest Seating Collection

Armless Side Chair

Designer(s):
Marc Krusin, 2011

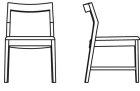

description	seat h	w	d	h	textile fabric yds.	required leather sq. ft.	weight	finish
MK01C Krusin armless chair 	18 1/2"	20 1/4"	21 3/4"	30 1/2"	0.8	14.5	12 lbs.	beech finish
	18 1/2"	20 1/4"	21 3/4"	30 1/2"	0.8	14.5	12 lbs.	ash or oak finish
	18 1/2"	20 1/4"	21 3/4"	30 1/2"	0.8	14.5	12 lbs.	walnut or lacquer finish
MK01CU Krusin armless chair, uphol. inset back 	18 1/2"	20 1/4"	21 3/4"	30 1/2"	0.8	14.5	12 lbs.	beech finish
	18 1/2"	20 1/4"	21 3/4"	30 1/2"	0.8	14.5	12 lbs.	ash or oak finish
	18 1/2"	20 1/4"	21 3/4"	30 1/2"	0.8	14.5	12 lbs.	walnut or lacquer finish
MK01R Seat basket replacement for side chair					0.8	14.5		
MK01RCN Woven rush seat basket replacement for side chair								light kraft

Order Code

<i>Example:</i>	MK01CU-OGW-H800/2
MK01CU	Krusin armless chair, uphol. inset back
OGW	Grey Oak with white ceruse
H800/2	Cato, Sand

Specify:

1. Pattern number
2. Woven rush seat, optional
3. Finish selection
4. Textile selection

Ordering Information:

Ash:
White Ash (suffix A101)

Beech frame stains:
Beech (suffix B311)
Bronzed Cherry (suffix B312A)
Burnt Walnut (suffix B313)
Deep Red Mahogany (suffix B328)
Ebonized (suffix BE)
Light Cherry (suffix B315)
Light Walnut (suffix B411)
Medium Cherry (suffix B319)
Medium Red Mahogany (suffix BR)
Medium Walnut (suffix B323)
Natural Beech (suffix BN)
Warm Brown Walnut (J)

Oak:
Ebonized Oak (suffix OE)
Fumed Oak (suffix OF)
Grey Oak, White Ceruse (suffix OGW)
Grey Oak, Black Ceruse (suffix OGB)
Natural Oak (suffix ON)

Walnut:
American Walnut (suffix AW)

Optional Woven Seat:
An optional woven paper rush seat is available at an upcharge, from grade A pricing, of \$276 for side chairs and \$309 for lounge chairs. Place suffix CN between parent pattern number and wood finish suffix.
Example:MK01C-CN-OGW

Upholstery/COM information:
List prices shown include fabric or leather upholstery. Contact your Knoll representative for colors. Only approved KnollTextiles and Spinneybeck leathers may be ordered.

Customer's Own Material is available pending approval. For approval requirements, processing instructions and ordering information please see page 18.

KnollStudio natural wood finishes:
The Krusin Collection of guest seating features a low sheen, Greenguard approved, urethane finish. This finish, available on Ash, Oak, and Walnut delivers the tactility of natural wood while providing a durable matte finish.

Ash and Oak feature a unique staining process that replicate traditional cereused finishes.

KnollStudio Beech wood finishes:
KnollStudio Beech finishes complement a large variety of KnollStudio veneer and Knoll Office veneer finishes. To select correct complementary finish, please refer to KnollStudio Wood Finish Matrix on page 25. If no complementary finish is available, please refer to custom finish policy below.

Custom finishes:
Complementary finishes to any KnollStudio or Knoll Office wood finish are available at no upcharge. To complement non-Knoll wood veneer or lumber finishes, a one-time, non-negotiable net upcharge of \$618 applies. Re-orders are at no upcharge. Please contact your KnollStudio representative, dealer or Customer Service associate for complete custom finish information and Order Code. Minimum order quantity for any custom finish order: 4 chairs.

Certified Wood:
Chairs manufactured using FSC certified hardwoods are available through Custom Product Development. Extended leadtime and upcharge apply.

Maintenance:
See pages 28-29

Note:
The Krusin Collection chairs are Greenguard certified in all wood finishes.

Cal 133 Fire Code:
The Krusin Side Chairs comply with the California Technical Bulletin 133 standard if upholstered in Cal 133 approved upholstery. Specify suffix -C at end of pattern number and suffix -133 at end of textile selection. Upcharge applies, see page 18.

Construction

Frame:
Select American and European hard wood frames. Dowel and mortise and tenon construction, steam bent top rail. A bent laminate upholstered inset back is available. The back of inset features horizontal grain direction.

Upholstered Seat:
High density, polyurethane foam used in all upholstered areas. Elastic seat belt suspension.

Woven Rush Seats:
A woven natural paper rush seat is available on side and lounge chairs. Not available on chairs with inset back upholstery. Paper rush is a natural, uncoated material.

KnollStudio will not warrant soiled or stained woven seats. A one year warranty will cover woven seats for manufacturer's defects.

Seat basket replacements:
Upholstered and woven seats sit on chair frame. Screws lock basket in place for easy installation or removal.

Finish:
Beech, Catalyzed lacquer protective coating. Hand applied final wax coating. Ash, Oak, and Walnut, urethane protective coating. Hand applied final wax coating.

Glides:
Chairs feature nylon glides.

pattern no.	grades	COM											COL				
	A	B	C	D	E	F	G	H	I	U	V	W	X	Y			
MK01C-()	\$1,003.	\$1,021.	\$1,039.	\$1,059.	\$1,074.	\$1,086.	\$1,105.	\$1,142.	\$1,169.	\$1,357.	\$1,409.	\$1,546.	\$1,573.	\$1,606.			
MK01C-(A101, O)	1,264.	1,279.	1,299.	1,318.	1,334.	1,345.	1,365.	1,403.	1,429.	1,633.	1,685.	1,822.	1,849.	1,882.			
MK01C-(AW, L)	1,578.	1,594.	1,613.	1,633.	1,649.	1,659.	1,679.	1,717.	1,743.	1,948.	1,999.	2,135.	2,163.	2,197.			
MK01CU-()	1,307.	1,324.	1,343.	1,363.	1,378.	1,388.	1,409.	1,446.	1,473.	1,660.	1,712.	1,849.	1,877.	1,910.			
MK01CU-(A101, O)	1,567.	1,583.	1,602.	1,622.	1,637.	1,649.	1,668.	1,706.	1,732.	1,936.	1,988.	2,125.	2,153.	2,186.			
MK01CU-(AW, L)	1,881.	1,898.	1,916.	1,936.	1,952.	1,963.	1,983.	2,020.	2,047.	2,252.	2,302.	2,439.	2,467.	2,501.			
MK01R	320.	337.	355.	376.	390.	402.	421.	459.	486.	679.	730.	867.	894.	928.			
MK01RCN	414.	0.	0.	0.	0.	0.	0.	0.	0.	0.	0.	0.	0.	0.			

Approved KnollTextiles Grades/Fabrics

A	Alignment ‡ Analogy Beacon Bocce ‡ Cat's Cradle ‡ Chance Common Ground ‡ Commuter Cloth ‡ Cotton Duck Delite Dristi Foil Rap Gala II Heavy Metal Hourglass Mariner Metaphor Monarch Prep ‡ Presto ‡ Soliloquy Sonnet Stacks ‡ Trophy ‡	B continued Ferry Forza Grande Grandview Holbrook Journey Keaton Knoll Felt Knoll Hopsack Ludlow Lyric Mini Stitch ‡ Night Life Nonchalant CR Odeon * Paradigm Petal Pusher Prairie Prim ‡ Radiance Ransom Ricochet ‡ Roam Rush Hour Soiree ‡ Spark ‡ Spinoff Nuance Spree ‡ Starry Night Summit Sutton Synth Tabloid Utmost Venue ‡ Versa ‡ Vinyl Westwood Wide Angle ‡ Zephyr Zipline ‡	C Atlas Autobahn Axiom Baxter Biota ‡ Cairo Charm Circa Classic Boucle Dahlia CR Decade Durand Earthwork ‡ Echo Empire Stripe Enmesh ‡ Entourage ‡ Fable CR * Fibra Greenwich Hudson Hula Hoop Kaleidoscope CR Kora CR Lagos Legend CR Lore CR Magnolia Metro Milestone Moto CR Noble Palisade Panache CR Posh Quark Regard CR Roundtrip ‡ Sahara Sandpiper Sequin CR Sinclair Smart	C continued Spectator ‡ Spot On Star Struck Stepping Stones Swing Tight Rope Tilden * Tower Grid Transition ‡ Treble CR Vibe Zari CR	D Compass CR Coterie Eclat Weave Hologram In The Loop Island Masquerade Menagerie Origins Satellite Satin Chisel Tara Theory Woodland Zoom	E Highland Ikat Stripe Ikat Square Kampala Katazome Kimono Luberon Mamba Marquee Sherman Shima Tryst Whip
----------	---	---	--	---	--	---

Spinneybeck Leather

F Atelier Biscayne Calais Cotton Velvet Century Coco Cornaro Eclipse Glider Icon Intrigue Liberty Mod Plaid Rivington Soon Topography Totem Tweed Frieze	G Arabella Djenne Gibson Hampshire * Haze Kamani Kinabalu Kingston Melange Metallic Gloss Sablon Serendipity Spencer Straie Stripe Ultrasuede Utrillo	H Arno Bavaria Constance Firefly Gezelle Magritte Rosemond	I Aswan Byron Canaan Cato Cummings Diamond Days Digi Velvet Dynamic Gates Ita Jaipur Knoll Velvet Mepal North Island Olema Piper Ravello Rutledge Sandis Tudor Vermeer Walker Worth Zimba	U Vicenza ‡ Volo ‡	V Acqua ‡ Andes ‡ Embossed Tip ‡ España ‡ Hand Tipped Maremma ‡ Velluto Pelle ‡	W Alaska ‡ Amazon ‡ Antique ‡ Arizona ‡ Derby Forte ‡ Lucente Sabrina ‡	X Ducale * ‡ Ducale Velour ‡	Y Capri * ‡ Cervo * ‡ Copenhagen ‡ Cordovan ‡ Distressed ‡ Lucca * ‡ Marissa ‡ Portofino Prima ‡ Riva ‡ Saddle Salon ‡ Torello * ‡
---	--	--	--	---------------------------------	---	--	---	--

*Not approved for inset back.
Check with your KnollTextiles or Spinneybeck Representative for changes or additions.

Marc Krusin

Guest Seating Collection

Lounge Seating

Designer(s):
Marc Krusin, 2011

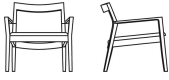
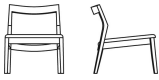

description	seat h	arm h	w	d	h	textile fabric yds.	required leather sq. ft.	weight	finish
MK02A Krusin Lounge arm chair 	16"	21 1/2"	27"	25 3/4"	26"	0.9	16.5	14 lbs.	beech finish
	16"	21 1/2"	27"	25 3/4"	26"	0.9	16.5	14 lbs.	ash or oak finish
	16"	21 1/2"	27"	25 3/4"	26"	0.9	16.5	14 lbs.	walnut finish
MK02C Krusin Lounge armless chair 	16"		23 1/2"	25 3/4"	26"	0.9	16.5	12 lbs.	beech finish
	16"		23 1/2"	25 3/4"	26"	0.9	16.5	12 lbs.	ash or oak finish
	16"		23 1/2"	25 3/4"	26"	0.9	16.5	12 lbs.	walnut finish
MK02R Seat basket replacement for lounge chair						0.9	16.5		
MK02RCN Woven rush seat basket replacement for lounge chair									light kraft

Order Code

<i>Example:</i>	MK02A-CN-A101
MK02A	Krusin lounge arm chair
CN	Woven rush seat
A101	White Ash

Specify:

1. Pattern number
2. Woven rush seat, optional
3. Finish selection
4. Textile selection

Ordering Information:

Ash:
White Ash (suffix A101)

Beech frame stains:
Beech (suffix B311)
Bronzed Cherry (suffix B312A)
Burnt Walnut (suffix B313)
Deep Red Mahogany (suffix B328)
Ebonized (suffix BE)
Light Cherry (suffix B315)
Light Walnut (suffix B411)
Medium Cherry (suffix B319)
Medium Red Mahogany (suffix BR)
Medium Walnut (suffix B323)
Natural Beech (suffix BN)
Warm Brown Walnut (J)

Oak:
Ebonized Oak (suffix OE)
Fumed Oak (suffix OF)
Grey Oak, White Ceruse (suffix OGW)
Grey Oak, Black Ceruse (suffix OGB)
Natural Oak (suffix ON)

Walnut:
American Walnut (suffix AW)

Optional Woven Seat:

An optional woven paper rush seat is available at an upcharge, from grade A pricing, of \$276 for side chairs and \$309 for lounge chairs. Place suffix CN between parent pattern number and wood finish suffix.

Example: **MK02A-CN-A101**

Upholstery/COM information:

List prices shown include fabric or leather upholstery. Contact your Knoll representative for colors. Only approved KnollTextiles and Spinneybeck leathers may be ordered.

Customer's Own Material is available pending approval. For approval requirements, processing instructions and ordering information please see page 18.

KnollStudio natural wood finishes:
The Krusin Collection of guest seating features a low sheen, Greenguard approved, urethane finish. This finish, available on Ash, Oak, and Walnut delivers the tactility of natural wood while providing a durable matte finish.

Ash and Oak feature a unique staining process that replicate traditional cerused finishes.

KnollStudio Beech wood finishes:

KnollStudio Beech finishes complement a large variety of KnollStudio veneer and Knoll Office veneer finishes. To select correct complementary finish, please refer to KnollStudio Wood Finish Matrix on page 25. If no complementary finish is available, please refer to custom finish policy below.

Custom finishes:

Complementary finishes to any KnollStudio or Knoll Office wood finish are available at no upcharge. To complement non-Knoll wood veneer or lumber finishes, a one-time, non-negotiable net upcharge of \$618 applies. Re-orders are at no upcharge. Please contact your KnollStudio representative, dealer or Customer Service associate for complete custom finish information and Order Code. Minimum order quantity for any custom finish order: 4 chairs.

Certified Wood:

Chairs manufactured using FSC certified hardwoods are available through Custom Product Development. Extended leadtime and upcharge apply.

Maintenance:

See pages 28-29

Note:

The Krusin Collection chairs are Greenguard certified in all wood finishes.

Cal 133 Fire Code #:

The Krusin Lounge Chairs comply with the California Technical Bulletin 133 standard if upholstered in Cal 133 approved upholstery. Specify suffix -C at end of pattern number and suffix -133 at end of textile selection. Upcharge applies, see page 18.

Construction

Frame:

Select American and European hard wood frames. Dowel and mortise and tenon construction, steam bent top rail.

Upholstered Seat:

High density, polyurethane foam used in all upholstered areas. Elastic seat belt suspension.

Woven Rush Seats:

A woven natural paper rush seat is available on side and lounge chairs. Not available on chairs with inset back upholstery. Paper rush is a natural, uncoated material.

KnollStudio will not warrant soiled or stained woven seats. A one year warranty will cover woven seats for manufacturer's defects.

Seat basket replacements:

Upholstered and woven seats sit on chair frame. Screws lock basket in place for easy installation or removal.

Finish:

Beech, Catalyzed lacquer protective coating. Hand applied final wax coating. Ash, Oak, and Walnut, urethane protective coating. Hand applied final wax coating.

Glides:

Chairs feature nylon glides.

pattern no.	grades	COM											COL				
	A	B	C	D	E	F	G	H	I	U	V	W	X	Y			
MK02A-()	\$1,611.	\$1,627.	\$1,649.	\$1,668.	\$1,686.	\$1,700.	\$1,721.	\$1,762.	\$1,793.	\$1,996.	\$2,057.	\$2,211.	\$2,243.	\$2,282.			
MK02A-(A101, O_)	1,677.	1,693.	1,714.	1,735.	1,753.	1,765.	1,788.	1,828.	1,859.	2,080.	2,140.	2,294.	2,327.	2,365.			
MK02A-(AW)	1,958.	1,976.	1,995.	2,016.	2,034.	2,047.	2,069.	2,109.	2,141.	2,362.	2,421.	2,575.	2,609.	2,646.			
MK02C-()	1,495.	1,512.	1,533.	1,552.	1,570.	1,583.	1,605.	1,647.	1,677.	1,881.	1,941.	2,095.	2,128.	2,166.			
MK02C-(A101, O_)	1,561.	1,578.	1,599.	1,619.	1,636.	1,650.	1,672.	1,712.	1,743.	1,964.	2,023.	2,178.	2,211.	2,250.			
MK02C-(AW)	1,843.	1,859.	1,880.	1,900.	1,918.	1,931.	1,953.	1,993.	2,024.	2,244.	2,305.	2,460.	2,492.	2,531.			
MK02R	397.	414.	433.	452.	468.	479.	499.	536.	562.	805.	857.	994.	1,022.	1,055.			
MK02RCN	447.	0.	0.	0.	0.	0.	0.	0.	0.	0.	0.	0.	0.	0.			

Approved KnollTextiles Grades/Fabrics

A	Alignment ‡ Analogy Beacon Boce ‡ Cat's Cradle ‡ Chance Common Ground ‡ Commuter Cloth ‡ Cotton Duck Delite Dristi Foil Rap Gala II Heavy Metal Hourglass Mariner Metaphor Monarch Prep ‡ Presto ‡ Soliloquy Sonnet Stacks ‡ Trophy ‡	B	Abacus ‡ Argyle Backdrop Bank Shot Belize Betwixt Bistro ‡ Boundary ‡ Cameo Chroma ‡ Chronicle Close Knit Digit Digital Tape Dovetail Fast Forward	C	Atlas Autobahn Axiom Baxter Biota ‡ Cairo Charm Circa Classic Boucle Dahlia CR Decade Durand Earthwork ‡ Echo Empire Stripe Enmesh ‡ Entourage ‡ Fable CR * Fibra Greenwich Hudson Hula Hoop Kaleidoscope CR Kora CR Lagos Legend CR Lore CR Magnolia Metro Milestone Moto CR Noble Palisade Panache CR Posh Quark Regard CR Roundtrip ‡ Sahara Sandpiper Sequin CR Sinclair Smart	C continued	Spectator ‡ Spot On Star Struck Stepping Stones Swing Tight Rope Tilden * Tower Grid Transition ‡ Treble CR Vibe Zari CR	D	Compass CR Coterie Eclat Weave Hologram In The Loop Island Masquerade Menagerie Origins Satellite Satin Chisel Tara Theory Woodland Zoom	E	Highland Ikat Stripe Ikat Square Kampala Katazome Kimono Luberon Mamba Marquee Sherman Shima Tryst Whip	F	Atelier Biscayne Calais Cotton Velvet Century Coco Cornaro Eclipse Glider Icon Intrigue Liberty Mod Plaid Rivington Soon Topography Totem Tweed Frieze	G	Arabella Djenne Gibson Hampshire * Haze Kamani Kinabalu Kingston Melange Metallic Gloss Sablon Serendipity Spencer Straie Stripe Ultrasuede Utrillo	H	Arno Bavaria Constance Firefly Gezelle Magritte Rosemond	I	Aswan Byron Canaan Cato Cummings Diamond Days Digi Velvet Dynamic Gates Ita Jaipur Knoll Velvet Mepal North Island Olema Piper Ravello Rutledge Sandis Tudor Vermeer Walker Worth Zimba	U	Vicenza ‡ Volo ‡	V	Acqua ‡ Andes ‡ Embossed Tip ‡ Hand Tipped España ‡ Maremma ‡ Velluto Pelle ‡	W	Alaska ‡ Amazon ‡ Antique ‡ Arizona ‡ Derby Forte ‡ Lucente Sabrina ‡	X	Ducale ‡ Ducale Velour ‡	Y	Capri ‡ Cervo ‡ Copenhagen ‡ Cordovan ‡ Distressed ‡ Lucca Marissa ‡ Portofino Prima ‡ Riva ‡ Saddle Salon ‡ Torello ‡
----------	--	----------	---	----------	--	--------------------	---	----------	--	----------	---	----------	---	----------	--	----------	--	----------	--	----------	---------------------	----------	---	----------	--	----------	-----------------------------	----------	--

Spinneybeck Leather

U	Vicenza ‡ Volo ‡	V	Acqua ‡ Andes ‡ Embossed Tip ‡ Hand Tipped España ‡ Maremma ‡ Velluto Pelle ‡	W	Alaska ‡ Amazon ‡ Antique ‡ Arizona ‡ Derby Forte ‡ Lucente Sabrina ‡	X	Ducale ‡ Ducale Velour ‡	Y	Capri ‡ Cervo ‡ Copenhagen ‡ Cordovan ‡ Distressed ‡ Lucca Marissa ‡ Portofino Prima ‡ Riva ‡ Saddle Salon ‡ Torello ‡
----------	---------------------	----------	---	----------	--	----------	-----------------------------	----------	--

Check with your KnollTextiles or Spinneybeck Representative for changes or additions.

Maya Lin

Stones

Seats and Coffee Table

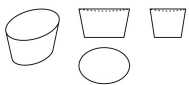
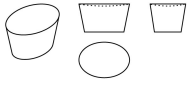
	description	w	d	h	material	textile fabric yds.	req. leather sq. ft.	weight
<p><i>Designer(s):</i> Maya Lin, 1998</p> <p><i>Award(s):</i> Best of Neocon Silver Award, 1998; Good Design Award, Chicago Athenaeum, 1998; Good Design Award, 2006</p> 	<p>83Y Stones adult seat</p> 	27"	19"	15"	molded polyethylene with weight			22 lbs.
	<p>83YM Stones adult seat</p> 	27"	19"	15"	molded polyethylene no weight			13 lbs.
	83Y-K Seat cushion for adult seat					1.3	30	

Order Code

<i>Example:</i>	84YM-W-KHRC-K642/5
84YM	Stones child seat
W	With weight
KHRC	Khaki
K642/5	Mariner, Steel

Specify:

1. Pattern number
2. Weight option
3. Finish option
4. Textile selection

Ordering Information:

Molded Polyethylene finish:
White (suffix WV)

Molded Polyethylene finishes with 100% recycled content:

Blue (suffix BLRC)
Chartreuse (CHRC)
Khaki (suffix KHRC)
Silver (suffix SPRC)
Tarmac (suffix TARC)
Warm Red (suffix WRRC)

Upholstery/COM information:

Prices shown include fabric or leather upholstery. Contact your Knoll representative for colors. Only approved Knoll Textiles and Spinneybeck leathers may be ordered.

Customer's Own Material is available pending approval. For approval requirements, processing instructions and ordering information please see page 18.

Seats and Table:

Stones are available in molded polyethylene in virgin or recycled material. Both versions are fully finished and are enclosed on top, bottom and sides. Seat tops are slightly concave and table top is slightly convex.

Note:

The original Maya Lin Coffee Table (85T42) is no longer available and has been replaced by a modified version (85T32). Please note the new dimensions and weight.

Outdoor application note:

With proper care and limited exposure to the elements, Stones tables and seats without seat pads are suitable for outdoor use. Polyethylene stones in all colors can be used outdoors. Remove water in the concave seats to avoid permanent stains. White patina may appear on surface. During cool or inclement weather, it is recommended to bring Stones inside.

Child seat application note:

Child seat is for child use only and not sized to be used by adults. Do not use as stepping stool.

Security Kit:

Security kit hooks onto latch on underside of polyethylene Stone directly into the ground for permanent applications. Due to variations in flooring, kit does not include hardware.

UV Testing:

Maya Lin Stones in polyethylene in all colors have passed UV testing standards including 100 hours under intense UV radiation to test for colorfastness.

Cal 133:

For polyethylene Maya Lin Stones in a Cal 133 finish please request through CPD. Please note, specifying the Maya Lin Stone seat pad in a Cal 133 textile does not make the polyethylene Stone Cal 133 approved.

Maintenance:

See pages 28-29.

Note:

The Maya Lin Seat and Coffee Table are Greenguard approved.

The Child's Maya Lin Stone is compliant to the Consumer Product Safety Improvement Act of 2008 for Children's Products, 16 C.F.R. 1303, CPSIA Title 1 Section 101 for Total Lead in Substrates and Surface Coatings.

Construction

Molded Polyethylene Stones:

Polyethylene stones have integral color with a light texture and a low gloss finish, available in one color.

Recycled Molded Polyethylene Stones:

Recycled polyethylene stones are composed of 100% recycled polyethylene in six colors. Black specs will appear randomly on the surface of the stone. Color will vary slightly from stone to stone. Warranty claims for color variations will not be honored.

Weighted Polyethylene Stones:

Adult and child stones in molded polyethylene can be specified with or without weight. For stones with weight, sand is added at the factory. Weight can be adjusted in the field through access on underside of the stones. There is no option for a sand kit if the Stones are ordered without weight. The coffee table can only be specified without weight.

Seat cushions (seats only):

Seat cushions are 2 1/4" thick, solid foam piece with tapered edge and fabric or leather zip-lock cover. Seat cushions are fully upholstered on top and bottom. Seat cushions are not attached to Stone.

pattern no.	unuphol.	grades	COM	A	B	C	D	E	F	G	H	I	COL	U	V	W	X	Y
83YMW-()	\$717.																	
83YM-()	607.																	
83Y-K-()		630.	662.	695.	729.	759.	780.	816.	882.	930.	1,292.	1,456.	1,796.	1,866.	1,950.			

Approved KnollTextiles Grades/Fabrics

A	Alignment ‡ Beacon Bocce Cat's Cradle Chance Common Ground ‡ Commuter Cloth ‡ Cotton Duck Delite Dristi Hourglass Mariner ‡ Monarch ‡ Prep ‡ Presto ‡ Soliloquy Sonnet Stacks Trophy	B	Abacus ‡ Argyle Backdrop Bank Shot Belize Betwixt Bistro ‡ Boundary ‡ Cameo Chroma ‡ Chronicle Close Knit ‡ Digit Dovetail ‡ Ferry Forza Gala II Grande Grandview Holbrook Journey Keaton Knoll Felt Knoll Hopsack	E continued	Ludlow Mini Stitch Night Life Nonchalant CR Palisade Paradigm Petal Pusher Pogo ‡ Pop Prairie Prim Radiance Ransom Ricochet ‡ Roam Rush Hour Soiree Spark ‡ Spinoff Nuance Spree Starry Night ‡ Summit Sutton Synth Tabloid Venue Versa Vinyl Westwood Wide Angle ‡ Zephyr Zipline	C continued	Empire Stripe Enmesh ‡ Entourage Fable CR Fibra Greenwich Hudson Hula Hoop Kaleidoscope CR Kora CR Lagos Legend CR Lore CR Magnolia Metro Milestone Moto CR Noble Panache CR Posh Quark Regard CR Roundtrip Sahara Sandpiper Sequin CR Sinclair Smart Spectator Spot On Star Struck Stepping Stones Swing Tilden Tower Grid Transition ‡ Treble CR Zari CR	D	Compass CR Coterie Eclat Weave Hologram Island Masquerade Menagerie Origins Satellite Satin Chisel Tara Theory Woodland Zoom	E	Fiori Highland Ikat Stripe Ikat Square Kampala Katazome Kimono Luberon Mamba Marquee Meroe Sherman Shima Tryst Whip	F continued	Glider Icon Liberty Mod Plaid Rivington Soon Topography Totem Tweed Frieze	G	Arabella Arber Djenne Gibson Hampshire Haze Kamani Kinabalu Kingston Melange Metallic Gloss Sablón Serendipity Spencer Straie Stripe Ultrasuede ‡ Utrillo	H	Arno Bavaria Constance Firefly Gezelle Magritte Rosemond Aswan Byron Canaan Cato Diamond Days Digi Velvet Dynamic Gates Ita Jaipur Knoll Velvet North Island Olema Piper Ravello Rutledge Tudor Vermeer Walker Worth Zimba	I		U	Vicenza Volo	V	Acqua Andes Embossed Tipped España Hand Tipped Velluto Pelle	W	Alaska Amazon Antique Arizona Derby Forte Lucente Sabrina	X	Ducale Ducale Velour	Y	Capri Cervo Copenhagen Cordovan Distressed Lucca Marissa Portofino Prima Riva Torello
----------	--	----------	---	--------------------	---	--------------------	---	----------	---	----------	---	--------------------	--	----------	---	----------	---	----------	--	----------	-----------------	----------	---	----------	--	----------	-------------------------	----------	---

Spinneybeck Leather



‡ Approved for Cal 133 upholstery.

Check with your KnollTextiles or Spinneybeck Representative for changes or additions.

Maya Lin

Stones

Seats and Coffee Table

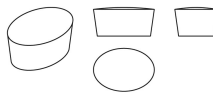
	description	w	d	h	material	textile fabric yds.	req. leather sq. ft.	weight
Designer(s): Maya Lin, 1998 Award(s): Best of Neocon Silver Award, 1998; Good Design Award, Chicago Athenaeum, 1998; Good Design Award, 2006 	84Y Stones child seat 	16"	12"	10"	molded polyethylene with weight			17 lbs.
	84YM Stones child seat 	16"	12"	10"	molded polyethylene no weight			6 lbs.
	84Y-K Seat cushion for child seat 					1.0	25	
	85T32M Stones coffee table 	32"	22 1/2"	15"	molded polyethylene no weight			26.5 lbs.

Order Code

<i>Example:</i>	84YM-W-KHRC-K642/5
84YM	Stones child seat
W	With weight
KHRC	Khaki
K642/5	Mariner, Steel

Specify:

1. Pattern number
2. Weight option
3. Finish option
4. Textile selection

Ordering Information:

Molded Polyethylene finish:
White (suffix WV)

Molded Polyethylene finishes with 100% recycled content:

- Blue (suffix BLRC)
- Chartreuse (CHRC)
- Khaki (suffix KHRC)
- Silver (suffix SPRC)
- Tarmac (suffix TARC)
- Warm Red (suffix WRRC)

Upholstery/COM information:

Prices shown include fabric or leather upholstery. Contact your Knoll representative for colors. Only approved Knoll Textiles and Spinneybeck leathers may be ordered.

Customer's Own Material is available pending approval. For approval requirements, processing instructions and ordering information please see page 18.

Seats and Table:

Stones are available in molded polyethylene in virgin or recycled material. Both versions are fully finished and are enclosed on top, bottom and sides. Seat tops are slightly concave and table top is slightly convex.

Note:

The original Maya Lin Coffee Table (85T42) is no longer available and has been replaced by a modified version (85T32). Please note the new dimensions and weight.

Outdoor application note:

With proper care and limited exposure to the elements, Stones tables and seats without seat pads are suitable for outdoor use. Polyethylene stones in all colors can be used outdoors. Remove water in the concave seats to avoid permanent stains. White patina may appear on surface. During cool or inclement weather, it is recommended to bring Stones inside.

Child seat application note:

Child seat is for child use only and not sized to be used by adults. Do not use as stepping stool.

Security Kit:

Security kit hooks onto latch on underside of polyethylene Stone directly into the ground for permanent applications. Due to variations in flooring, kit does not include hardware.

UV Testing:

Maya Lin Stones in polyethylene in all colors have passed UV testing standards including 100 hours under intense UV radiation to test for colorfastness.

Cal 133:

For polyethylene Maya Lin Stones in a Cal 133 finish please request through CPD. Please note, specifying the Maya Lin Stone seat pad in a Cal 133 textile does not make the polyethylene Stone Cal 133 approved.

Maintenance:

See pages 28-29.

Note:

The Maya Lin Seat and Coffee Table are Greenguard approved.

The Child's Maya Lin Stone is compliant to the Consumer Product Safety Improvement Act of 2008 for Children's Products, 16 C.F.R. 1303, CPSIA Title 1 Section 101 for Total Lead in Substrates and Surface Coatings.

Construction

Molded Polyethylene Stones:

Polyethylene stones have integral color with a light texture and a low gloss finish, available in one color.

Recycled Molded Polyethylene Stones:

Recycled polyethylene stones are composed of 100% recycled polyethylene in six colors. Black specs will appear randomly on the surface of the stone. Color will vary slightly from stone to stone. Warranty claims for color variations will not be honored.

Weighted Polyethylene Stones:

Adult and child stones in molded polyethylene can be specified with or without weight. For stones with weight, sand is added at the factory. Weight can be adjusted in the field through access on underside of the stones. There is no option for a sand kit if the Stones are ordered without weight. The coffee table can only be specified without weight.

Seat cushions (seats only):

Seat cushions are 2 1/4" thick, solid foam piece with tapered edge and fabric or leather zip-lock cover. Seat cushions are fully upholstered on top and bottom. Seat cushions are not attached to Stone.

pattern no.	unuphol.	grades	COM	A	B	C	D	E	F	G	H	I	COL	U	V	W	X	Y
84YMW-()	\$482.																	
84YM-()	417.																	
84Y-K-()		460.	494.	523.	555.	581.	598.	630.	695.	740.	1,143.	1,298.	1,608.	1,676.	1,749.			
85T32M-()	1,092.																	

Approved KnollTextiles Grades/Fabrics

A	Alignment ‡ Beacon Bocce Cat's Cradle Chance Common Ground ‡ Commuter Cloth ‡ Cotton Duck Delite Dristi Hourglass Mariner ‡ Monarch ‡ Prep ‡ Presto ‡ Soliloquy Sonnet Stacks Trophy	B	Abacus ‡ Argyle Backdrop Bank Shot Belize Betwixt Bistro ‡ Boundary ‡ Cameo Chroma ‡ Chronicle Close Knit ‡ Digit Dovetail ‡ Ferry Forza Gala II Grande Grandview Holbrook Journey Keaton Knoll Felt Knoll Hopsack	E continued	Ludlow Mini Stitch Night Life Nonchalant CR Palisade Paradigm Petal Pusher Pogo ‡ Pop Prairie Prim Radiance Ransom Ricochet ‡ Roam Rush Hour Soiree Spark ‡ Spinoff Nuance Spree Starry Night ‡ Summit Sutton Synth Tabloid Venue Versa Vinyl Westwood Wide Angle ‡ Zephyr Zipline	C continued	Empire Stripe Enmesh ‡ Entourage Fable CR Fibra Greenwich Hudson Hula Hoop Kaleidoscope CR Kora CR Lagos Legend CR Lore CR Magnolia Metro Milestone Moto CR Noble Panache CR Posh Quark Regard CR Roundtrip Sahara Sandpiper Sequin CR Sinclair Smart Spectator Spot On Star Struck Stepping Stones Swing Tilden Tower Grid Transition ‡ Treble CR Zari CR	D	Compass CR Coterie Eclat Weave Hologram Island Masquerade Menagerie Origins Satellite Satin Chisel Tara Theory Woodland Zoom	E	Fiori Highland Ikat Stripe Ikat Square Kampala Katazome Kimono Luberon Mamba Marquee Meroe Sherman Shima Tryst Whip	F continued	Glider Icon Liberty Mod Plaid Rivington Soon Topography Totem Tweed Frieze	G	Arabella Arber Djenne Gibson Hampshire Haze Kamani Kinabalu Kingston Melange Metallic Gloss Sablón Serendipity Spencer Straie Stripe Ultrasuede ‡ Utrillo	H	Arno Bavaria Constance Firefly Gezelle Magritte Rosemond Aswan Byron Canaan Cato Diamond Days Digi Velvet Dynamic Gates Ita Jaipur Knoll Velvet North Island Olema Piper Ravello Rutledge Tudor Vermeer Walker Worth Zimba	I		U	Vicenza Volo	V	Acqua Andes Embossed Tipped España Hand Tipped Velluto Pelle	W	Alaska Amazon Antique Arizona Derby Forte Lucente Sabrina	X	Ducale Ducale Velour	Y	Capri Cervo Copenhagen Cordovan Distressed Lucca Marissa Portofino Prima Riva Torello
----------	--	----------	---	--------------------	---	--------------------	---	----------	---	----------	---	--------------------	--	----------	---	----------	---	----------	--	----------	-----------------	----------	---	----------	--	----------	-------------------------	----------	---

Spinneybeck Leather

U	Vicenza Volo	V	Acqua Andes Embossed Tipped España Hand Tipped Velluto Pelle	W	Alaska Amazon Antique Arizona Derby Forte Lucente Sabrina	X	Ducale Ducale Velour	Y	Capri Cervo Copenhagen Cordovan Distressed Lucca Marissa Portofino Prima Riva Torello
----------	-----------------	----------	---	----------	--	----------	-------------------------	----------	---

‡ Approved for Cal 133 upholstery.

Check with your KnollTextiles or Spinneybeck Representative for changes or additions.

Maya Lin

Stones

Seats and Coffee Table

description	w	d	h	material	textile fabric yds.	req. leather sq. ft.	weight
<i>Designer(s):</i> Maya Lin, 1998	83ANCHOR Stone Security Kit						

Award(s):
Best of Neocon Silver Award,
1998; Good Design Award,
Chicago Athenaeum, 1998; Good
Design Award, 2006



Order Code

<i>Example:</i>	84YM-W-KHRC-K642/5
84YM	Stones child seat
W	With weight
KHRC	Khaki
K642/5	Mariner, Steel

Specify:

1. Pattern number
2. Weight option
3. Finish option
4. Textile selection

Ordering Information:

Molded Polyethylene finish:
White (suffix WV)

Molded Polyethylene finishes with 100% recycled content:

Blue (suffix BLRC)
Chartreuse (CHRC)
Khaki (suffix KHRC)
Silver (suffix SPRC)
Tarmac (suffix TARC)
Warm Red (suffix WRRC)

Upholstery/COM information:
Prices shown include fabric or leather upholstery. Contact your Knoll representative for colors. Only approved KnollTextiles and Spinneybeck leathers may be ordered.

Customer's Own Material is available pending approval. For approval requirements, processing instructions and ordering information please see page 18.

Seats and Table:

Stones are available in molded polyethylene in virgin or recycled material. Both versions are fully finished and are enclosed on top, bottom and sides. Seat tops are slightly concave and table top is slightly convex.

Note:

The original Maya Lin Coffee Table (85T42) is no longer available and has been replaced by a modified version (85T32). Please note the new dimensions and weight.

Outdoor application note:

With proper care and limited exposure to the elements, Stones tables and seats without seat pads are suitable for outdoor use. Polyethylene stones in all colors can be used outdoors. Remove water in the concave seats to avoid permanent stains. White patina may appear on surface. During cool or inclement weather, it is recommended to bring Stones inside.

Child seat application note:

Child seat is for child use only and not sized to be used by adults. Do not use as stepping stool.

Security Kit:

Security kit hooks onto latch on underside of polyethylene Stone directly into the ground for permanent applications. Due to variations in flooring, kit does not include hardware.

UV Testing:

Maya Lin Stones in polyethylene in all colors have passed UV testing standards including 100 hours under intense UV radiation to test for colorfastness.

Cal 133:

For polyethylene Maya Lin Stones in a Cal 133 finish please request through CPD. Please note, specifying the Maya Lin Stone seat pad in a Cal 133 textile does not make the polyethylene Stone Cal 133 approved.

Maintenance:

See pages 28-29.

Note:

The Maya Lin Seat and Coffee Table are Greenguard approved.

The Child's Maya Lin Stone is compliant to the Consumer Product Safety Improvement Act of 2008 for Children's Products, 16 C.F.R. 1303, CPSIA Title 1 Section 101 for Total Lead in Substrates and Surface Coatings.

Construction

Molded Polyethylene Stones:

Polyethylene stones have integral color with a light texture and a low gloss finish, available in one color.

Recycled Molded Polyethylene Stones:

Recycled polyethylene stones are composed of 100% recycled polyethylene in six colors. Black specs will appear randomly on the surface of the stone. Color will vary slightly from stone to stone. Warranty claims for color variations will not be honored.

Weighted Polyethylene Stones:

Adult and child stones in molded polyethylene can be specified with or without weight. For stones with weight, sand is added at the factory. Weight can be adjusted in the field through access on underside of the stones. There is no option for a sand kit if the Stones are ordered without weight. The coffee table can only be specified without weight.

Seat cushions (seats only):

Seat cushions are 2 1/4" thick, solid foam piece with tapered edge and fabric or leather zip-lock cover. Seat cushions are fully upholstered on top and bottom. Seat cushions are not attached to Stone.

pattern no.	unuphol.	grades	COM								COL				
		A	B	C	D	E	F	G	H	I	U	V	W	X	Y
83ANCHOR	\$143.														

Approved KnollTextiles Grades/Fabrics

A	Alignment ‡ Beacon Bocce Cat's Cradle Chance Common Ground ‡ Commuter Cloth ‡ Cotton Duck Delite Dristi Hourglass Mariner ‡ Monarch ‡ Prep ‡ Presto ‡ Soliloquy Sonnet Stacks Trophy	B	Abacus ‡ Argyle Backdrop Bank Shot Belize Betwixt Bistro ‡ Boundary ‡ Cameo Chroma ‡ Chronicle Close Knit ‡ Digit Dovetail ‡ Ferry Forza Gala II Grande Grandview Holbrook Journey Keaton Knoll Felt Knoll Hopsack	E continued	Ludlow Mini Stitch Night Life Nonchalant CR Palisade Paradigm Petal Pusher Pogo ‡ Pop Prairie Prim Radiance Ransom Ricochet ‡ Roam Rush Hour Soiree Spark ‡ Spinoff Nuance Spree Starry Night ‡ Summit Sutton Synth Tabloid Venue Versa Vinyl Westwood Wide Angle ‡ Zephyr Zipline	C continued	Empire Stripe Enmesh ‡ Entourage Fable CR Fibra Greenwich Hudson Hula Hoop Kaleidoscope CR Kora CR Lagos Legend CR Lore CR Magnolia Metro Milestone Moto CR Noble Panache CR Posh Quark Regard CR Roundtrip Sahara Sandpiper Sequin CR Sinclair Smart Spectator Spot On Star Struck Stepping Stones Swing Tilden Tower Grid Transition ‡ Treble CR Zari CR	D	Compass CR Coterie Eclat Weave Hologram Island Masquerade Menagerie Origins Satellite Satin Chisel Tara Theory Woodland Zoom	E	Fiori Highland Ikat Stripe Ikat Square Kampala Katazome Kimono Luberon Mamba Marquee Meroe Sherman Shima Tryst Whip	F continued	Glider Icon Liberty Mod Plaid Rivington Soon Topography Totem Tweed Frieze	G	Arabella Arber Djenne Gibson Hampshire Haze Kamani Kinabalu Kingston Kampala Metallic Gloss Sablon Serendipity Spencer Straie Stripe Ultrasuede ‡ Utrillo	H	Arno Bavaria Constance Firefly Gezelle Magritte Rosemond	I	Aswan Byron Canaan Cato Diamond Days Digi Velvet Dynamic Gates Ita Jaipur Knoll Velvet North Island Olema Piper Ravello Rutledge Tudor Vermeer Walker Worth Zimba	U	Vicenza Volo	V	Acqua Andes Embossed Tipped España Hand Tipped Velluto Pelle	W	Alaska Amazon Antique Arizona Derby Forte Lucente Sabrina	X	Ducale Ducale Velour	Y	Capri Cervo Copenhagen Cordovan Distressed Lucca Marissa Portofino Prima Riva Torello
----------	--	----------	---	--------------------	---	--------------------	---	----------	---	----------	---	--------------------	--	----------	---	----------	--	----------	---	----------	-----------------	----------	---	----------	--	----------	-------------------------	----------	---

Spinneybeck Leather

U	Vicenza Volo	X	Ducale Ducale Velour
V	Acqua Andes Embossed Tipped España Hand Tipped Velluto Pelle	Y	Capri Cervo Copenhagen Cordovan Distressed Lucca Marissa Portofino Prima Riva Torello
W	Alaska Amazon Antique Arizona Derby Forte Lucente Sabrina		

‡ Approved for Cal 133 upholstery.

Check with your KnollTextiles or Spinneybeck Representative for changes or additions.

Piero Lissoni

Divina® Lounge Seating

Designer(s):
Piero Lissoni, 2001

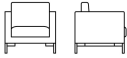
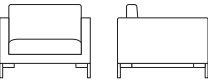

description	seat h	arm h	w	d	h	foam type	textile fabric yds.	req. leather sq. ft.	weight
67S Petite lounge chair 	16 1/4"	24 1/2"	30 1/2"	31 1/4"	32 1/2"	standard	4.5	72	42 lbs.
67 Standard lounge chair 	16 1/4"	24 1/4"	37"	35 1/2"	31 1/4"	standard	7.5	108	59 lbs.
	16 1/4"	24 1/4"	37"	35 1/2"	31 1/4"	dual density	7.5	108	59 lbs.

Order Code

<i>Example:</i>	69R-K1052/7
69R	Divina sofa, dual density
K1052/7	Topography, Canyon
<i>Example:</i>	68C-K1052/7
68C	Divina side cushion
K1052/7	Topography, Canyon

Specify:

1. Pattern number
2. R for dual density cushions
3. Textile selection

Side cushion, specify:

1. Pattern number
2. Textile selection

Ordering Information

Upholstery/COM information:

Prices shown include fabric or leather upholstery. Contact your Knoll representative for colors. Only approved Knoll Textiles and Spinneybeck leathers may be ordered.

Customer's Own Material is available pending approval. For approval requirements, processing instructions and ordering information please see page 18.

Optional Side Cushion:

One or two cushions can be specified for the standard lounge chair, settee and sofa. Side cushion is composed of polyurethane with polyester wrap. Since cushion is not fitted, it is available in fabric only.

Cal 133 Fire Code ▲:

The Divina Lounge collection complies with the California Technical Bulletin 133 standard if upholstered in Cal 133 approved upholstery. Specify suffix -C at end of pattern number and suffix -133 at end of textile or leather selection. For Cal 133 approval, leather units must be double upholstered: in the F187 fabric barrier and then in leather. Upcharge applies, see page 18.

Maintenance:

See pages 28-29.

Note:

The Divina Lounge Collection is Greenguard certified.

Construction

Frame:

Inner frame solid wood. Exposed metal frame and legs in heavy gauge tubular steel in polished chrome finish.

Feet:

Chrome-plated feet with polyurethane glides measuring 5.75" high.

Standard Cushions:

Seat cushion in polyurethane with polyester fiber wrap. Back cushion in polyurethane. Cushions are not reversible.

Dual Density Cushions:

Back cushion is polyurethane. Seat cushion is dual density foam: a soft foam core with a memory topper. Cushions are not reversible.

Upholstery:

Double-needled stitching on leather upholstery. Double-needled stitching on thin solid textiles, single-needled stitching on heavily ribbed fabrics and multicolor prints.

pattern no.	COL													
	A	B	C	D	E	F	G	H	I	U	V	W	X	Y
67S-()	\$4,904.	\$5,083.	\$5,258.	\$5,447.	\$5,602.	\$5,714.	\$5,906.	\$6,265.	\$6,536.	\$7,918.	\$8,568.	\$9,887.	\$10,161.	\$10,481.
67-()	5,651.	5,893.	6,123.	6,377.	6,587.	6,735.	6,994.	7,476.	7,835.	9,575.	10,450.	12,223.	12,593.	13,022.
67R-()	5,934.	6,185.	6,430.	6,697.	6,917.	7,072.	7,342.	7,851.	8,226.	10,052.	10,972.	12,833.	13,223.	13,674.

Approved KnollTextiles Grades/Fabrics

A	Alignment ‡ Beacon Bocce Cat's Cradle Common Ground Commuter Cloth ‡ Cotton Duck Delite Hourglass Mariner Monarch ‡ Prep ‡ Presto ‡ Sonnet Stacks Trophy	B	Abacus ‡ Argyle Bank Shot ‡ Belize Betwixt Bistro ‡ Cameo Chance Chroma Chronicle Digit Ferry	E continued	Grandview Holbrook Journey ‡ Keaton Knoll Felt Knoll Hopsack Ludlow Lyric Nonchalant CR Paradigm Petal Pusher Pogo Pop Prairie Prim Radiance Ransom Ricochet ‡ Roam Rush Hour Soiree Spark ‡ Spinoff Nuance Spree Starry Night ‡ Summit Sutton ‡ Synth Tabloid Venue Versa Vinyl Westwood Wide Angle ‡ Zephyr Zipline	C	Atlas Axiom Biota ‡ Cairo Charm Circa Classic Boucle ‡ Dahlia CR Durand Earthwork ‡ Echo Empire Stripe Entourage Fable CR Fibra Gala II Greenwich Hudson Hula Hoop Kaleidoscope CR Kora CR Lagos Lore CR Metro Milestone Moto CR Palisade Panache CR	C continued	Quark Roundtrip Sahara Sandpiper Sequin CR Spot On Star Struck Stepping Stones Swing Tight Rope Tilden Tower Grid Transition ‡ Zari CR	D	Coterie Origins Eclat Weave Hologram Island Masquerade Menagerie Satellite Satin Chisel Tara Theory Woodland Zoom	E	Highland Kampala Katazome Luberon Mamba Marquee Meroe Ikat Stripe Ikat Square Shima Tryst Whip	F	Atelier Biscayne Calais Cotton Velvet Century Coco Cornaro Eclipse Icon Intrigue Liberty Mod Plaid Rivington Soon Topography Totem
----------	---	----------	--	--------------------	--	----------	---	--------------------	---	----------	---	----------	---	----------	---

Spinneybeck Leather

U	Vicenza ‡ Volo ‡	X	Ducale ‡ Ducale Velour ‡
V	Acqua ‡ Andes ‡ Serendipity España ‡ Hand Tipped Velluto Pelle ‡	Y	Capri ‡ Cervo Copenhagen ‡ Cordovan ‡ Distressed ‡ Marissa ‡ Prima ‡ Riva ‡ Saddle ‡
W	Alaska ‡ Amazon ‡ Antique ‡ Arizona ‡ Derby ‡ Forte ‡ Lucente Sabrina ‡		

‡ Approved for Cal 133 upholstery.

Check with your KnollTextiles or Spinneybeck Representative for changes or additions.

Piero Lissoni

Divina® Lounge Seating

Designer(s):
Piero Lissoni, 2001

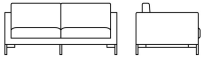
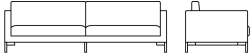

description	seat h	arm h	w	d	h	foam type	textile fabric yds.	req. leather sq. ft.	weight
68 Settee 	16 1/4"	24 1/4"	66"	35 1/2"	31 1/4"	standard	11.3	163	83 lbs.
	16 1/4"	24 1/4"	66"	35 1/2"	31 1/4"	dual density	11.3	163	83 lbs.
69 Sofa 	16 1/4"	24 1/4"	91"	35 1/2"	31 1/4"	standard	13.3	192	130 lbs.
	16 1/4"	24 1/4"	91"	35 1/2"	31 1/4"	dual density	13.3	192	130 lbs.

Order Code

<i>Example:</i>	69R-K1052/7
69R	Divina sofa, dual density
K1052/7	Topography, Canyon
<i>Example:</i>	68C-K1052/7
68C	Divina side cushion
K1052/7	Topography, Canyon

Specify:

1. Pattern number
2. R for dual density cushions
3. Textile selection

Side cushion, specify:

1. Pattern number
2. Textile selection

Ordering Information

Upholstery/COM information:

Prices shown include fabric or leather upholstery. Contact your Knoll representative for colors. Only approved Knoll Textiles and Spinneybeck leathers may be ordered.

Customer's Own Material is available pending approval. For approval requirements, processing instructions and ordering information please see page 18.

Optional Side Cushion:

One or two cushions can be specified for the standard lounge chair, settee and sofa. Side cushion is composed of polyurethane with polyester wrap. Since cushion is not fitted, it is available in fabric only.

Cal 133 Fire Code #:

The Divina Lounge collection complies with the California Technical Bulletin 133 standard if upholstered in Cal 133 approved upholstery. Specify suffix -C at end of pattern number and suffix -133 at end of textile or leather selection. For Cal 133 approval, leather units must be double upholstered: in the F187 fabric barrier and then in leather. Upcharge applies, see page 18.

Maintenance:

See pages 28-29.

Note:

The Divina Lounge Collection is Greenguard certified.

Construction

Frame:

Inner frame solid wood. Exposed metal frame and legs in heavy gauge tubular steel in polished chrome finish.

Feet:

Chrome-plated feet with polyurethane glides measuring 5.75" high.

Standard Cushions:

Seat cushion in polyurethane with polyester fiber wrap. Back cushion in polyurethane. Cushions are not reversible.

Dual Density Cushions:

Back cushion is polyurethane. Seat cushion is dual density foam: a soft foam core with a memory topper. Cushions are not reversible.

Upholstery:

Double-needled stitching on leather upholstery. Double-needled stitching on thin solid textiles, single-needled stitching on heavily ribbed fabrics and multicolor prints.

pattern no.	COL													
	grades	A	B	C	D	E	F	G	H	I	U	V	W	X
68- ()	\$8,565.	\$8,936.	\$9,292.	\$9,684.	\$10,001.	\$10,232.	\$10,628.	\$11,371.	\$11,920.	\$14,615.	\$15,954.	\$18,684.	\$19,254.	\$19,915.
68R- ()	8,992.	9,383.	9,757.	10,168.	10,501.	10,746.	11,160.	11,940.	12,517.	15,344.	16,752.	19,620.	20,218.	20,911.
69- ()	9,688.	10,173.	10,632.	11,137.	11,550.	11,849.	12,353.	13,315.	14,029.	18,556.	20,289.	23,806.	24,544.	25,395.
69R- ()	10,173.	10,680.	11,164.	11,695.	12,127.	12,440.	12,971.	13,979.	14,728.	19,482.	21,300.	24,997.	25,770.	26,665.

Approved KnollTextiles Grades/Fabrics

A	Alignment ‡ Beacon Bocce Cat's Cradle Common Ground Commuter Cloth ‡ Cotton Duck Delite Hourglass Mariner Monarch ‡ Prep ‡ Presto ‡ Sonnet Stacks Trophy	B	Abacus ‡ Argyle Bank Shot ‡ Belize Betwixt Bistro ‡ Cameo Chance Chroma Chronicle Digit Ferry	E continued	Grandview Holbrook Journey ‡ Keaton Knoll Felt Knoll Hopsack Ludlow Lyric Nonchalant CR Paradigm Petal Pusher Pogo Pop Prairie Prim Radiance Ransom Ricochet ‡ Roam Rush Hour Soiree Spark ‡ Spinoff Nuance Spree Starry Night ‡ Summit Sutton ‡ Synth Tabloid Venue Versa Vinyl Westwood Wide Angle ‡ Zephyr Zipline	C	Atlas Axiom Biota ‡ Cairo Charm Circa Classic Boucle ‡ Dahlia CR Durand Earthwork ‡ Echo Empire Stripe Entourage Fable CR Fibra Gala II Greenwich Hudson Hula Hoop Kaleidoscope CR Kora CR Lagos Lore CR Metro Milestone Moto CR Palisade Panache CR	C continued	Quark Roundtrip Sahara Sandpiper Sequin CR Spot On Star Struck Stepping Stones Swing Tight Rope Tilden Tower Grid Transition ‡ Zari CR	D	Coterie Origins Eclat Weave Hologram Island Masquerade Menagerie Satellite Satin Chisel Tara Theory Woodland Zoom	E	Highland Kampala Katazome Luberon Mamba Marquee Meroe Ikat Stripe Ikat Square Shima Tryst Whip	F	Atelier Biscayne Calais Cotton Velvet Century Coco Cornaro Eclipse Icon Intrigue Liberty Mod Plaid Rivington Soon Topography Totem
----------	---	----------	--	--------------------	--	----------	---	--------------------	---	----------	---	----------	---	----------	---

Spinneybeck Leather

U	Vicenza ‡ Volo ‡	X	Ducale ‡ Ducale Velour ‡
V	Acqua ‡ Andes ‡ Serendipity España ‡ Hand Tipped Velluto Pelle ‡	Y	Capri ‡ Cervo Copenhagen ‡ Cordovan ‡ Distressed ‡ Marissa ‡ Prima ‡ Riva ‡ Saddle ‡
W	Alaska ‡ Amazon ‡ Antique ‡ Arizona ‡ Derby ‡ Forte ‡ Lucente Sabrina ‡		

‡ Approved for Cal 133 upholstery.



Check with your KnollTextiles or Spinneybeck Representative for changes or additions.

Piero Lissoni

Divina® Lounge Seating

Designer(s):
Piero Lissoni, 2001



description	seat h	arm h	w	d	h	foam type	textile fabric yds.	req. leather sq. ft.	weight
68C Optional side cushion for standard chair, settee and sofa 			21"	2½"	13¼"	standard	1	n/a	5 lbs.
73 Ottoman 			29½"	29½"	16"	standard	4.1	43	27 lbs.
			29½"	29½"	16"	dual density	4.1	43	27 lbs.

Order Code

<i>Example:</i>	69R-K1052/7
69R	Divina sofa, dual density
K1052/7	Topography, Canyon
<i>Example:</i>	68C-K1052/7
68C	Divina side cushion
K1052/7	Topography, Canyon

Specify:

1. Pattern number
2. R for dual density cushions
3. Textile selection

Side cushion, specify:

1. Pattern number
2. Textile selection

Ordering Information

Upholstery/COM information:

Prices shown include fabric or leather upholstery. Contact your Knoll representative for colors. Only approved Knoll Textiles and Spinneybeck leathers may be ordered.

Customer's Own Material is available pending approval. For approval requirements, processing instructions and ordering information please see page 18.

Optional Side Cushion:

One or two cushions can be specified for the standard lounge chair, settee and sofa. Side cushion is composed of polyurethane with polyester wrap. Since cushion is not fitted, it is available in fabric only.

Cal 133 Fire Code ▲:

The Divina Lounge collection complies with the California Technical Bulletin 133 standard if upholstered in Cal 133 approved upholstery. Specify suffix -C at end of pattern number and suffix -133 at end of textile or leather selection. For Cal 133 approval, leather units must be double upholstered: in the F187 fabric barrier and then in leather. Upcharge applies, see page 18.

Maintenance:

See pages 28-29.

Note:

The Divina Lounge Collection is Greenguard certified.

Construction

Frame:

Inner frame solid wood. Exposed metal frame and legs in heavy gauge tubular steel in polished chrome finish.

Feet:

Chrome-plated feet with polyurethane glides measuring 5.75" high.

Standard Cushions:

Seat cushion in polyurethane with polyester fiber wrap. Back cushion in polyurethane. Cushions are not reversible.

Dual Density Cushions:

Back cushion is polyurethane. Seat cushion is dual density foam: a soft foam core with a memory topper. Cushions are not reversible.

Upholstery:

Double-needled stitching on leather upholstery. Double-needled stitching on thin solid textiles, single-needled stitching on heavily ribbed fabrics and multicolor prints.

pattern no.	grades A	COM B	C	D	E	F	G	H	I	COL U	V	W	X	Y
68C-()	\$588.	\$620.	\$653.	\$688.	\$717.	\$741.	\$775.	\$846.	\$893.					
73-()	2,925.	3,052.	3,171.	3,301.	3,408.	3,488.	3,620.	3,869.	3,913.	4,056.	4,174.	4,708.	4,818.	4,948.
73R-()	3,071.	3,204.	3,330.	3,467.	3,578.	3,664.	3,801.	4,063.	4,109.	4,258.	4,384.	4,944.	5,059.	5,195.

Approved KnollTextiles Grades/Fabrics

A	Alignment ‡ Beacon Bocce Cat's Cradle Common Ground Commuter Cloth ‡ Cotton Duck Delite Hourglass Mariner Monarch ‡ Prep ‡ Presto ‡ Sonnet Stacks Trophy	B	Abacus ‡ Argyle Bank Shot ‡ Belize Betwixt Bistro ‡ Cameo Chance Chroma Chronicle Digit Ferry	E continued	Grandview Holbrook Journey ‡ Keaton Knoll Felt Knoll Hopsack Ludlow Lyric Nonchalant CR Paradigm Petal Pusher Pogo Pop Prairie Prim Radiance Ransom Ricochet ‡ Roam Rush Hour Soiree Spark ‡ Spinoff Nuance Spree Starry Night ‡ Summit Sutton ‡ Synth Tabloid Venue Versa Vinyl Westwood Wide Angle ‡ Zephyr Zipline	C	Atlas Axiom Biota ‡ Cairo Charm Circa Classic Boucle ‡ Dahlia CR Durand Earthwork ‡ Echo Empire Stripe Entourage Fable CR Fibra Gala II Greenwich Hudson Hula Hoop Kaleidoscope CR Kora CR Lagos Lore CR Metro Milestone Moto CR Palisade Panache CR	C continued	Quark Roundtrip Sahara Sandpiper Sequin CR Spot On Star Struck Stepping Stones Swing Tight Rope Tilden Tower Grid Transition ‡ Zari CR	D	Coterie Origins Eclat Weave Hologram Island Masquerade Menagerie Satellite Satin Chisel Tara Theory Woodland Zoom	E	Highland Kampala Katazome Luberon Mamba Marquee Meroe Ikat Stripe Ikat Square Shima Tryst Whip	F	Atelier Biscayne Calais Cotton Velvet Century Coco Cornaro Eclipse Icon Intrigue Liberty Mod Plaid Rivington Soon Topography Totem
----------	---	----------	--	--------------------	--	----------	---	--------------------	---	----------	---	----------	---	----------	---

Spinneybeck Leather



U	Vicenza ‡ Volo ‡	X	Ducale ‡ Ducale Velour ‡
V	Acqua ‡ Andes ‡ Embossed Tipped España ‡ Hand Tipped Velluto Pelle ‡	Y	Capri ‡ Cervo Copenhagen ‡ Cordovan ‡ Distressed ‡ Marissa ‡ Prima ‡ Riva ‡ Saddle ‡
W	Alaska ‡ Amazon ‡ Antique ‡ Arizona ‡ Derby ‡ Forte ‡ Lucente Sabrina ‡		
I	Byron Cato Diamond Days Digi Velvet Dynamic Gates Knoll Velvet Olema Piper Ravello Rutledge Sandis Tudor Vermeer Walker Worth Zimba		

Check with your KnollTextiles or Spinneybeck Representative for changes or additions.

Ross Lovegrove Sprite Armless Chair

Designer(s):
Ross Lovegrove, 2004



description	face/back	seat h	w	d	h	textile fabric yds.	leather sq ft.	weight
27C Same finish, face and back 	maple/maple	17"	22"	22"	32"	0.5	10	10 lbs.
	paint A/paint A	17"	22"	22"	32"	0.5	10	10 lbs.
	veneer/veneer	17"	22"	22"	32"	0.5	10	10 lbs.
27C Combination face and back 	maple/paint or paint/maple	17"	22"	22"	32"	0.5	10	10 lbs.
	paint A/paint B or paint B/Paint A	17"	22"	22"	32"	0.5	10	10 lbs.
	veneer/paint or paint/veneer	17"	22"	22"	32"	0.5	10	10 lbs.
Sprite Dolly 			14.5"	31"	26.5"			10 lbs.
27CGA Sprite Ganging Mechanism, Armless								
TR Sprite Tablet Arm				9 1/4"	13"			

Order Code

Example: **27CTR-KC-BL-C-K(VP-BLK)**

27C	Armless chair
TR	Tablet Arm (\$394 list upcharge)
KC	Rotary Maple face
BL	Black painted back
C	Chrome legs
K	Seat cushion
VP-BLK	Velluto Pelle, Black

Specify:

1. Pattern number
2. Optional tablet arm (\$394 list upcharge)
3. Finish selection, face
4. Finish selection, back
5. Leg finish (chrome only)
6. Seat cushion option
7. Textile selection

Ordering Information:



Maple finish:

 Rotary Maple (suffix KC)

Exotic Alpi and Veneer finishes:

Beech (suffix BN)
Cherry (suffix CY)
Walnut (suffix WA)
Zebra (suffix ZE)
Macasser Ebony (suffix ME)
Black and White Woodgrain (suffix WB)

Paint finishes:

 Black (suffix BL)
Grey (suffix SL)
Lime (suffix LI)
Navy (suffix NA)
Red (suffix RD)
 White (suffix WV)

Leg finish:

 Chrome (suffix C)

KnollStudio 20-Day Program:

The Sprite armless chair with a chrome base and white, black or rotary maple shells are available on the 20-day program. For more specific information, please consult pages 30-33.

Maintenance:

See pages 28-29.

Cal 133 Fire Code ♣:

The Sprite chair complies with the Cal 133 standard if unupholstered or if upholstered in Cal 133 approved upholstery. Specify suffix -C at end of pattern number and suffix -133 at end of textile selection. Upcharge applies, see page 19.

Note:

The Sprite Chair in Maple, Exotic Alpi and Veneer finishes are Greenguard certified.

Construction

Shell:

Molded plywood shell made of six layers of maple and three layers of adhesive.

Alpi Veneers:

Reconstituted veneers made of both plantation poplar and Obce/Ayous, a bland African wood from well-managed sources with a long term forestry management plan.

Paint:

Smooth highly durable paint.

Edge finish:

On chairs painted one color, edge will be painted. For chairs in two-tone combination or with veneer option, edges are natural maple. For chairs in exotic Alpi veneer finish, edges are natural maple. For high use applications, maple or veneer options are recommended.

Base:

3/8" tubular steel with mirror chrome finish. Shell connected to the seat with four screws. Four rubber bumpers assure proper stacking.

Upholstery:

Seat pad, upholstered in fabric or leather with urethane foam. Water based glue used for upholstery. Seat pad is attached to chair by four screws.

Stacking:

Armless Sprite chairs without seatpad can stack 8-10 high, with seatpad, 4-6.

Transportation Dolly:

Chrome plated steel frame with rubber wheels, 10-12 Sprite armless chairs can stack on a dolly. Dolly with 10 armless chairs measures: 53" h x 40" w x 22" d

Ganging Mechanism:

Armless mechanism measures 7.4". Device is constructed of a low durometer thermoplastic elastomer with a neodymium magnet. When not in use, the mechanism is easily stored (magnetized) to the underside of the chair.

Tablet Arm:

Tablet is right-handed with a fixed, chrome-plated arm. Integral to the frame, the tablet is black laminate with a 1/2" beveled birch edge. Tablet is factory installed and cannot be retrofitted in the field. For left handed version, please contact CPD. Sprite tablet arm passes BIFMA standards. Sprite chairs with tablet arm stack 4 high.

pattern no.	unuphol. (remove suffix -k)	grades A	COM B	C	D	E	F	G	H	I	COL.				
											U	V	W	X	Y
27C-(KC)-(KC) -C-K	\$600.	\$750.	\$767.	\$781.	\$798.	\$811.	\$823.	\$838.	\$871.	\$893.	\$994.	\$1,056.	\$1,183.	\$1,211.	\$1,242.
27C-()-() -C-K	720.	873.	887.	904.	918.	933.	943.	959.	992.	1,015.	1,115.	1,177.	1,305.	1,333.	1,364.
27C-()-)-C-K	1,054.	1,205.	1,218.	1,236.	1,250.	1,265.	1,275.	1,293.	1,324.	1,347.	1,447.	1,510.	1,637.	1,664.	1,695.
27C-()-)-C-K	1,054.	1,205.	1,218.	1,236.	1,250.	1,265.	1,275.	1,293.	1,324.	1,347.	1,447.	1,510.	1,637.	1,664.	1,695.
27C-()-)-C-K	1,054.	1,205.	1,218.	1,236.	1,250.	1,265.	1,275.	1,293.	1,324.	1,347.	1,447.	1,510.	1,637.	1,664.	1,695.
27DOLLY	661.														
27CGA	26.														
TR	466.														

Approved KnollTextiles Grades/Fabrics

A	B continued	C continued	C continued
Alignment	Holbrook	Cairo	Tight Rope
Analogy	Journey	Charm	Tilden
Bocce	Keaton	Circa	Tower Grid
Cat's Cradle	Knoll Felt	Classic Boucle	Transition
Common Ground	Knoll Hopsack	Decade	Treble CR
Commuter Cloth	Ludlow	Durand	Zari CR
Cotton Duck	Lyric	Earthwork	
Dristi	Mini Stitch	Echo	D
Foil Rap	Night Life	Empire Stripe	Compass CR
Heavy Metal	Nonchalant CR	Fable CR	Coterie
Hourglass	Paradigm	Fibra	Eclat Weave
Mariner	Petal Pusher	Greenwich	Hologram
Metaphor	Pogo	Hudson	In The Loop
Monarch	Pop	Hula Hoop	Island
Prep	Prairie	Kaleidoscope CR	Masquerade
Presto	Prim	Lagos	Menagerie
Sonnet	Radiance	Legend CR	Origins
Stacks	Ransom	Lore CR	Satellite
	Ricochet	Metro	Satin Chisel
B	Rush Hour	Milestone	Tara
Abacus	Soiree	Moto CR	Woodland
Argyle	Spark	Palisade	Zoom
Backdrop	Spinoff Nuance	Posh	
Bank Shot	Spree	Quark	E
Belize	Starry Night	Regard CR	Ikat Square
Betwixt	Summit	Roundtrip	Ikat Stripe
Bistro	Sutton	Sandpiper	Kampala
Cameo	Versa	Smart	Katazome
Boundary	Vinyl	Spectator	Kimono
Chronicle	Westwood	Star Struck	Luberon
Close Knit	Wide Angle	Stepping Stones	Mamba
Digit	Zephyr		Marquee
Digital Tape	Zipline		Meroe
Dovetail			Sherman
Fast Forward	C		Shima
Forza	Atlas		Whip
Grande	Autobahn		
Grandview	Axiom		
	Biota		

Spinneybeck Leather

U	V
Vicenza	Capri
Volo	Cervo
	Copenhagen
V	Cordovan
Acqua	Distressed
Andes	Marissa
Embossed Tipped	Portofino
España	Prima
Hand Tipped	Riva
Maremma	Saddle
Velluto Pelle	Salon
	Torrello
W	
Alaska	
Amazon	
Antique	
Arizona	
Derby	
Forte	
Lucente	
Sabrina	
X	
Ducale	
Ducale Velour	



Approved for Cal 133 upholstery.

Check with your KnollTextiles or Spinneybeck Representative for changes or additions.

Ross Lovegrove Sprite Arm Chair

Designer(s):
Ross Lovegrove, 2004



description	face/back/arm	arm h	seat h	w	d	h	textile fabric yds.	leather sq ft.	weight
27A Same finish, face and back 	maple/maple/urethane arms	25 1/2"	17"	29"	22"	32"	0.5	10	13 lbs.
	paint A/paint A/urethane arms	25 1/2"	17"	29"	22"	32"	0.5	10	13 lbs.
	veneer/veneer/urethane arms	25 1/2"	17"	29"	22"	32"	0.5	10	13 lbs.
27A Combination, face and back 	maple/paint or paint/maple urethane arms	25 1/2"	17"	29"	22"	32"	0.5	10	13 lbs.
	paint A/paint B or paint B/paint A urethane arms	25 1/2"	17"	29"	22"	32"	0.5	10	13 lbs.
	veneer/paint or paint/veneer urethane arms	25 1/2"	17"	29"	22"	32"	0.5	10	13 lbs.
Sprite Dolly 				14.5"	31"	26.5"			10 lbs.

27AGA Sprite Ganging Mechanism, Arm

Order Code

Example: **27C-KC-BL-C-BP-K(VP-BLK)**

27C	Armless chair
KC	Rotary Maple face
BL	Black painted back
C	Chrome legs
BP	Urethane arms
K	Seat cushion
VP-BLK	Velluto Pelle, Black

Specify:

1. Pattern number
2. Finish selection, face
3. Finish selection, back
4. Leg finish (chrome only)
5. Arm finish
6. Seat cushion option
7. Textile selection

Ordering Information:

Maple finish:
Rotary Maple (suffix KC)

Exotic Alpi and Veneer finishes:

Beech (suffix BN)
Cherry (suffix CY)
Walnut (suffix WA)
Zebra (suffix ZE)
Macassar Ebony (suffix ME)
Black and White Woodgrain (suffix WB)

Paint finishes:

Black (suffix BL)
Grey (suffix SL)
Lime (suffix LI)
Navy (suffix NA)
Red (suffix RD)
White (suffix WV)

Leg finish:

Chrome (suffix C)

Maintenance:

See pages 28-29.

Cal 133 Fire Code ♣:

The Sprite chair complies with the Cal 133 standard if upholstered or if upholstered in Cal 133 approved upholstery. Specify suffix -C at end of pattern number and suffix -133 at end of textile selection. Upcharge applies, see page 19.

Note:

The Sprite Chair in Maple, Exotic Alpi and Veneer finishes are Greenguard certified.

Construction

Shell:

Molded plywood shell made of six layers of maple and three layers of adhesive.

Paint:

Smooth highly durable paint.

Edge finish:

On chairs painted one color, edge will be painted. For chairs in two-tone combination or with veneer option, edge will be natural maple. For chairs in Exotic Alpi veneer finish, edges are natural maple. For high use applications, maple or veneer options are recommended.

Base:

3/8" tubular steel with mirror chrome finish. Shell connected to the seat with four screws. Four rubber bumpers assure proper stacking.

Upholstery:

Seat pad, upholstered in fabric or leather with urethane foam. Water based glue used for upholstery. Seat pad is attached to chair by four screws.

Armpads:

Black self skinning polyurethane pads (available on painted or maple/veneer chairs).

Stacking:

Arm Sprite chairs with or without seatpad can stack 4-6 high.

Transportation Dolly:

Chrome-plated steel frame with rubber wheels. 4-6 Sprite arm chairs stack on a dolly. Dolly with 10 armless chairs measures:
53" h x 40" w x 29" d

Ganging Mechanism

Arm mechanism measures 10". Device is constructed of a low durometer thermoplastic elastomer with a neodymium magnet. When not in use, the mechanism is easily stored (magnetized) to the underside of the chair.

pattern no.	unuphol. (remove suffix -k)	grades A	COM B	C	D	E	F	G	H	I	COL U	V	W	X	Y
27A-(KC)-(KC)-C-(BP)-K	\$817.	\$971.	\$988.	\$1,002.	\$1,022.	\$1,036.	\$1,045.	\$1,065.	\$1,097.	\$1,122.	\$1,225.	\$1,292.	\$1,423.	\$1,452.	\$1,483.
27A-(-)(-)-C-(BP)-K	1,223.	1,379.	1,396.	1,410.	1,429.	1,444.	1,452.	1,473.	1,506.	1,527.	1,632.	1,698.	1,830.	1,860.	1,891.
27A-(-)(-)-C-(BP)-K	1,223.	1,379.	1,396.	1,410.	1,429.	1,444.	1,452.	1,473.	1,506.	1,527.	1,632.	1,698.	1,830.	1,860.	1,891.
27A-(KC)-(-)-C-(BP)-K	915.	1,071.	1,089.	1,102.	1,123.	1,135.	1,145.	1,164.	1,198.	1,218.	1,325.	1,391.	1,522.	1,553.	1,584.
27A-(-)(-)-C-(BP)-K	1,223.	1,379.	1,396.	1,410.	1,429.	1,444.	1,452.	1,473.	1,506.	1,527.	1,632.	1,698.	1,830.	1,860.	1,891.
27A-(-)(-)-C-(BP)-K	1,223.	1,379.	1,396.	1,410.	1,429.	1,444.	1,452.	1,473.	1,506.	1,527.	1,632.	1,698.	1,830.	1,860.	1,891.
27DOLLY	661.														
27AGA	26.														

Approved KnollTextiles Grades/Fabrics





A Alignment ‡ Analogy Bocce Cat's Cradle Common Ground Commuter Cloth ‡ Cotton Duck Dristi Foil Rap Heavy Metal Hourglass Mariner Metaphor Monarch ‡ Prep ‡ Presto ‡ Sonnet Stacks	B continued Holbrook Journey Keaton Knoll Felt ‡ Knoll Hopsack ‡ Ludlow Lyric Mini Stitch ‡ Night Life Nonchalant CR Paradigm Petal Pusher Pogo Pop Prairie Prim Radianc Ransom Ricochet ‡ Roam Rush Hour Soiree Spark ‡ Spinoff Nuance Spree Starry Night ‡ Summit Sutton ‡ Versa Vinyl Westwood Wide Angle ‡ Zephyr Zipline	C continued Cairo Charm Circa Classic Boucle Dahlia CR Decade Durand Earthwork ‡ Echo Empire Stripe Fable CR Fibra Greenwich Hudson Hula Hoop Kaleidoscope CR Lagos Legend CR Lore CR Metro Milestone Moto CR Palisade Quark Regard CR Roundtrip Sandpiper Smart Spectator Star Struck Stepping Stones	C continued Tight Rope Tilden Tower Grid Transition ‡ Treble CR Zari CR D Compass CR Coterie Eclat Weave Hologram In The Loop Island Masquerade Menagerie Origins Satellite Satin Chisel Tara Theory Woodland Zoom E Ikat Square Ikat Stripe Kampala Katazome Kimono Luberon Mamba Marquee Meroe Sherman Shima Whip	F Atelier Biscayne Calais Cotton Velvet Century Coco Eclipse Glider Icon Intrigue Liberty Mod Plaid Rivington Soon Topography Totem Tweed Frieze	G Arabella Djenne Gibson Hampshire Haze Kamani Kinabalu Mélange Sablon Serendipity Spencer Straie Stripe Ultrasuede ‡	H Arno Bavaria Constance Firefly Gezelle Magritte Rosemond I Aswan Byron Canaan Cato Diamond Days Digi Velvet Dynamic Gates Ita Jaipur Knoll Velvet North Island Olema Piper Ravello Rutledge Sandis Vermeer Walker Worth Zimba	U Vicenza ‡ Volo ‡ V Acqua Andes Embossed Tipped España Hand Tipped Maremma Velluto Pelle W Alaska Amazon Antique Arizona Derby Forte Lucente	W continued Sabrina X Ducale Ducale Velour Y Capri Cervo Copenhagen Cordovan Distressed Lucca Marissa Portofino Prima Riva Saddle Salon Torello
---	--	--	---	--	---	--	--	--

Spinneybeck Leather

‡ Approved for Cal 133 upholstery.
Check with your KnollTextiles or Spinneybeck Representative for changes or additions.

Ross Lovegrove

Sprite Medium and Small Armless Chair

	description	face/back	seat h	w	d	h
<i>Designer(s):</i> Ross Lovegrove, 2004	27CM Medium chair. Same finish, face and back 	maple/maple	14 1/2"	18 3/4"	18 3/4"	27 1/4"
		paint A / paint A	14 1/2"	18 3/4"	18 3/4"	27 1/4"
	27CM Medium chair. Combination face and back 	maple/paint or paint/maple	14 1/2"	18 3/4"	18 3/4"	27 1/4"
		paint A/paint B or paint B/paint A	14 1/2"	18 3/4"	18 3/4"	27 1/4"
	27CS Small chair. Same finish, face and back 	maple/maple	12 3/4"	16 1/2"	16 1/2"	24"
		paint A / paint A	12 3/4"	16 1/2"	16 1/2"	24"
	27CS Small chair. Combination face and back 	maple/paint or paint/maple	12 3/4"	16 1/2"	16 1/2"	24"
		paint A/paint B or paint B/paint A	12 3/4"	16 1/2"	16 1/2"	24"

Order Code

<i>Example:</i>	27CM-KC-NA-C
27CM	Medium armless chair
KC	Rotary Maple face
NA	Navy painted back
C	Chrome legs

Specify:

1. Pattern number
2. Finish selection, face
3. Finish selection, back
4. Leg finish (chrome only)

Ordering Information

Maple finish:
Rotary Maple (suffix KC)

Paint finishes:
Black (suffix BL)
Grey (suffix SL)
Lime (suffix LI)
Navy (suffix NA)
Red (suffix RD)
White (suffix WV)

Leg finish:
Chrome (suffix C)

Maintenance:
See pages 0-0

Construction

Shell:
Molded plywood shell made of six layers of maple and three layers of adhesive.

Paint:
Smooth highly durable paint.

Edge finish:
On chairs painted one color, edge will be painted. For chairs in two-tone combination option, edges are natural maple. For high use applications, maple option is recommended.

Base:
3/8" tubular steel with mirror chrome finish. Shell connected to the seat with four screws. Four rubber bumpers assure proper stacking.

Stacking:
Medium and Small Armless Sprite chairs can stack 8-10 high.

pattern no.

27CM-(KC)-(KC)-C	\$493.
27CM-(-)-(-)-C	605.

27CM-(-)-(-)-C	605.
-----------------------	------

27CM-(-)-(-)-C	605.
-----------------------	------

27CS-(KC)-(KC)-C	493.
-------------------------	------

27CS-(-)-(-)-C	605.
-----------------------	------





27CS-(-)-(-)-C	605.
-----------------------	------

27CS-(-)-(-)-C	605.
-----------------------	------

Vico Magistretti Cirene Stacking Chair

Designer(s):
Vico Magistretti, 1999

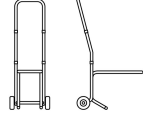

description	seat h	arm h	w	d	h	weight	
46A Arm chair, unupholstered 	18"	24 ³ / ₈ "	22 ³ / ₈ "	20 ¹ / ₂ "	29 ¹ / ₂ "	14 lbs.	
	18"	24 ⁷ / ₈ "	22 ⁷ / ₈ "	20 ¹ / ₂ "	29 ¹ / ₂ "	14 lbs.	
46A-U Arm chair, upholstered 	18"	24 ³ / ₈ "	22 ³ / ₈ "	20 ¹ / ₂ "	29 ¹ / ₂ "	15 lbs.	
46C Armless chair, unupholstered 	18"		21"	21 ¹ / ₄ "	29 ¹ / ₂ "	11 lbs.	
	18"		21"	21 ¹ / ₄ "	29 ¹ / ₂ "	11 lbs.	
46C-U Armless chair, upholstered 	18"		21"	21 ¹ / ₄ "	29 ¹ / ₂ "	13 lbs.	
59Dolly Dolly for 8 Cirene chairs, unupholstered 				15 ³ / ₄ "	27 ¹ / ₂ "	43 ¹ / ₈ "	7 lbs.
L Arm / Armless chair with ganging mechanism, installed, stored under seat							

Order Code

Example:	46C-W-L
46C	Cirene armless stacking chair
W	White shell
L	With ganging mechanism
Example:	46A-U-MA
46A-U	Cirene arm chair, upholstered
MA	Brown Leather

Ordering Information

Melamine Shell Finishes:
White (suffix W)

Paint Shell Finishes:
Charcoal (suffix CG)

Veneer Shell Finishes:
Maple (suffix KC)
Wengè-stained oak (suffix WE)

Transportation Dolly:

Aluminum frame with rubber wheels. Up to 8 Cirene chairs can be loaded on the dolly. Dolly with 6 chairs measures 39" high, 8 chairs measures 43" high.

Stackability:

The Cirene unupholstered chair and armchair stack 10 high. The upholstered versions do not stack.

Ganging Mechanism:

Mechanism ships installed underneath the seat. Composed of chrome-plated steel, the hook stores underneath the seat and pulls out for ganging. Chairs stack with ganging mechanism installed. Add suffix L to pattern number.

Note:

For high use and high traffic areas, the Cirene chairs with veneer or melamine shell is recommended.

The Cirene Stacking Chair is Greenguard certified.

Maintenance:

See pages 28-29.

Specify:

1. Pattern number
2. Shell color
3. Ganging option (suffix L)

For leather option, specify:

1. Pattern number
2. Textile selection

pattern no.	unuphol.	fabric	leather
46A(CG,W)	\$1,258.		
46A-(KC,WE)	1,323.		
<hr/>			
46A-U()		1,704.	2,377.
<hr/>			
46C-(CG,W)	1,044.		
46C-(KC,WE)	1,105.		
<hr/>			
46C-U()		1,584.	2,266.
<hr/>			
59Dolly	1,234.		
<hr/>			
L	132.		
<hr/>			

Construction

Description:
 Molded plywood shell in natural veneer finish (maple, wengè); smooth paint finish (charcoal); melamine finish with plywood edge (white). Frame is chrome-plated tubular steel. Arm chair features black polypropylene molded armpads. Armpads are not removable and cannot be retrofitted.

Fabric & Leather cover:
 Cirene can be ordered with full cover. Plywood-shell is covered with pad and fabric/leather is attached with velcro on the underside of the chair. Cover is not removable.



Approved Textiles

Trevira textile colors:
 Plain weave cross-dye fabrics:
 Blue (F941741)
 Orange (F941511)
 Red (F941521)

Leather colors:
 Tabacco (TA)
 Black (NE)

For samples of leathers and fabrics, please contact your KnollStudio sales representative.

Marco Maran Gigi® Arm Chair

	description	seat h	arm h	w	d	h	textile fabric yds.	weight
Designer(s): Marco Maran, 2000 	87A Arm chair, stacking 	18"	26 1/2"	19 3/4"	20"	34 1/4"		14 lbs.
	87A-K-N Arm chair with seat pad, non-stacking 	18"	26 1/2"	19 3/4"	20"	34 1/4"	0.7	15 lbs.

Order Code





<i>Example:</i>	87A-014
87A	Gigi arm stacking chair
014	Black shell

Specify:

1. Pattern number
2. Shell finish
3. Textile selection

Ordering Information

Shell finishes:

-  Black (suffix 014)
-  Graphite (suffix 003)
- Mango (suffix 006)
-  Navy (suffix 012)
-  Red (suffix 007)
- Seafoam (suffix 010)
-  White (suffix 001)

KnollStudio 20-Day Program:

Gigi arm chair is available on the 20-day program, unupholstered, in white, graphite, black, red and navy shell finishes. For specific ordering information consult pages 27-28.

Upholstery/Com information:

Prices shown include fabric or leather upholstery. Contact your Knoll representative for colors. Only approved KnollTextiles and Spinneybeck leathers may be ordered.

Customer's Own Material is available pending approval. For approval requirements, processing instructions and ordering information, please see page 18.

Maintenance:

See pages 28-29.

Stacking feature:

Gigi armless unupholstered chairs stack 4 high on floor.

Gigi armless chairs with seat pad and bumper stack 4 high on floor.

Gigi armless chairs with seat pad and stacking bumper stack 8-10 high on a dolly.

Gigi arm chair with seat pad and stacking bumper stack 4 high on floor and dolly.

Gigi arm chair stacks 4 high on floor and dolly.

Gigi chairs with seatpad without bumper (87CK-N, 87AK-N) do not stack.

Note:

The Gigi Chair is Greenguard certified.

Construction

Description:

Coloured polypropylene shell on a chrome-plated base. Arm chairs have black polypropylene molded arm pads. Chair back flexes for comfort. Gigi chairs are easily cleaned in food areas and work with a booster seat.

Seat Pad:

Seat pad is permanently attached to the seat with bolts in the factory. Seat pad is not retrofittable in the field. Constructed of ABS with high resilient foam.

Stacking bumper:

Black flexible urethane stacking pad secured between base and shell.

Transportation Dolly:

Chrome plated steel frame with rubber wheels. 10 Gigi armless chairs can be stacked on the dolly. Dollies can stack three high for compact storage. Dolly with 10 chairs will measure 56.3" h, 19.75" w, 41" d. Dolly does not lock.

pattern no.	unuphol.	A	COM B	C	D	E	F	G	H	I
87A-() 	\$684.									
87A-K-N-()-()		954.	969.	986.	1,001.	1,017.	1,026.	1,044.	1,075.	1,100.

Approved KnollTextiles Grades/Fabrics

Tablet Arm:

The tablet attaches to the chair frame underneath the seat. It is aligned with the front leg and has a flip up mechanism. Tablet is black melamine. Steel support with chrome finish. Tablet arm can be used with armless chair only. Gigi with tablet can be stacked 4 high on the floor and on the dolly.

Note:

Tablet arm option is not offered with stacking bumper.





Ganging Mechanism:

The easy-to-detach ganging mechanism links two adjoining frames at the front legs or rear legs. Ganging mechanism consists of black molded polypropylene. Chairs with ganging mechanism can be stacked. Tablet arm ships separate from the chair and can be retrofitted in the field. Arm chairs can not be ganged with armless chairs.

A	Alignment Analogy Bocce Cat's Cradle Chance Common Ground Commuter Cloth Cotton Duck Delite Dristi Foil Rap Heavy Metal Hourglass Mariner Metaphor Monarch Prep Presto Soliloquy Sonnet Stacks	B	continued Gala II Grande Grandview Holbrook Journey Keaton Knoll Felt Knoll Hopsack Ludlow Lyric Mini Stitch Night Life Paradigm Petal Pusher Pogo Pop Prairie Prim Radiance Ransom Ricochet Roam Rush Hour Soiree Spark Spinoff Nuance Spree Starry Night Summit Sutton Tabloid Venue Versa Westwood Wide Angle Zephyr Zipline	C	continued Dahlia CR Decade Durand Earthwork Echo Enmesh Entourage Fable CR Fibra Greenwich Hudson Hula Hoop Kaleidoscope CR Kora CR Legend CR Lore CR Metro Milestone Moto CR Noble Palisade Panache CR Quark Regard CR Roundtrip Sandpiper Sequin CR Sinclair Smart Spectator Spot On Star Struck Stepping Stones Swing Tight Rope Tilden Tower Grid Transition	C	continued Treble CR Vibe Zari CR	D	Compass CR Coterie Eclat Weave Hologram Island In The Loop Masquerade Menagerie Origins Satellite Satin Chisel Tara Theory Woodland Zoom	E	Highland Ikat Square Ikat Stripe Kampala Katazome Kimono Luberon Mamba Marquee Meroc Sherman Tryst Whip	F	Atelier Biscayne Calais Cotton Velvet Century Coco Cornaro Eclipse Glider Icon Intrigue Mod Plaid Liberty Rivington Soon Topography Totem Tweed Frieze	G	Arabella Djenne Gibson Hampshire Haze Kamani Kinabalu Melange Sablon Serendipity Straie Stripe Ultrasuede	H	Arno Bavaria Constance Firefly Gezelle Magritte Rosemond	I	Aswan Byron Canaan Cato Cummings Dynamic Gates Diamond Days Digi Velvet Ita Jaipur Mepal Olema Piper Rutledge Sandis Vermeer Walker Worth Zimba
----------	--	----------	--	----------	--	----------	---	----------	--	----------	---	----------	---	----------	--	----------	--	----------	--

Check with your KnollTextiles representative for changes or additions.

Marco Maran Gigi® Arm Chair

	description	seat h	arm h	w	d	h	textile fabric yds.	weight
Designer(s): Marco Maran, 2000 	87A-K-S Arm chair with seat pad, stacking 	18"	26 1/2"	19 3/4"	20"	34 1/4"	0.7	16 lbs.
	87Dolly Dolly for 10 Gigi chairs 				19.2"	31"	26 1/2"	
	87Tablet Folding tablet arm, right for armless chair 				9 3/4"	12"		
	87GA Gigi ganging mechanism 							

Order Code





<i>Example:</i>	87A-014
87A	Gigi arm stacking chair
014	Black shell

Specify:

1. Pattern number
2. Shell finish
3. Textile selection

Ordering Information

Shell finishes:

-  Black (suffix 014)
-  Graphite (suffix 003)
- Mango (suffix 006)
-  Navy (suffix 012)
-  Red (suffix 007)
- Seafoam (suffix 010)
-  White (suffix 001)

KnollStudio 20-Day Program:

Gigi arm chair is available on the 20-day program, unupholstered, in white, graphite, black, red and navy shell finishes. For specific ordering information consult pages 27-28.

Upholstery/Com information:

Prices shown include fabric or leather upholstery. Contact your Knoll representative for colors. Only approved KnollTextiles and Spinneybeck leathers may be ordered.

Customer's Own Material is available pending approval. For approval requirements, processing instructions and ordering information, please see page 18.

Maintenance:

See pages 28-29.

Stacking feature:

Gigi armless unupholstered chairs stack 4 high on floor.
 Gigi armless chairs with seat pad and bumper stack 4 high on floor.
 Gigi armless chairs with seat pad and stacking bumper stack 8-10 high on a dolly.
 Gigi arm chair with seat pad and stacking bumper stack 4 high on floor and dolly.
 Gigi arm chair stacks 4 high on floor and dolly.
 Gigi chairs with seatpad without bumper (87CK-N, 87AK-N) do not stack.

Note:

The Gigi Chair is Greenguard certified.

Construction

Description:

Coloured polypropylene shell on a chrome-plated base. Arm chairs have black polypropylene molded arm pads. Chair back flexes for comfort. Gigi chairs are easily cleaned in food areas and work with a booster seat.

Seat Pad:

Seat pad is permanently attached to the seat with bolts in the factory. Seat pad is not retrofittable in the field. Constructed of ABS with high resilient foam.

Stacking bumper:

Black flexible urethane stacking pad secured between base and shell.

Transportation Dolly:

Chrome plated steel frame with rubber wheels. 10 Gigi armless chairs can be stacked on the dolly. Dollies can stack three high for compact storage. Dolly with 10 chairs will measure 56.3" h, 19.75" w, 41" d. Dolly does not lock.

pattern no.	unuphol.	COM								
		A	B	C	D	E	F	G	H	I
87A-K-S-(-)(-)		\$1,050.	\$1,067.	\$1,083.	\$1,100.	\$1,114.	\$1,125.	\$1,142.	\$1,176.	\$1,201.

87Dolly	722.
---------	------

87TABLET	296.
----------	------



87GA	36.
------	-----

Approved KnollTextiles Grades/Fabrics

<p><i>Tablet Arm:</i> The tablet attaches to the chair frame underneath the seat. It is aligned with the front leg and has a flip up mechanism. Tablet is black melamine. Steel support with chrome finish. Tablet arm can be used with armless chair only. Gigi with tablet can be stacked 4 high on the floor and on the dolly.</p> <p><i>Note:</i> Tablet arm option is not offered with stacking bumper.</p> <p><i>Ganging Mechanism:</i> The easy-to-detach ganging mechanism links two adjoining frames at the front legs or rear legs. Ganging mechanism consists of black molded polypropylene. Chairs with ganging mechanism can be stacked. Tablet arm ships separate from the chair and can be retrofitted in the field. Arm chairs can not be ganged with armless chairs.</p>	A	B continued	C continued	C continued	F	H
	Alignment	Gala II	Dahlia CR	Treble CR	Atelier	Arno
	Analogy	Grande	Decade	Vibe	Biscayne	Bavaria
	Bocce	Grandview	Durand	Zari CR	Calais Cotton	Constance
	Cat's Cradle	Holbrook	Earthwork		Velvet	Firefly
	Chance	Journey	Echo	D	Century	Gezelle
	Common Ground	Keaton	Enmesh	Compass CR	Coco	Magritte
	Commuter Cloth	Knoll Felt	Entourage	Coterie	Cornaro	Rosemond
	Cotton Duck	Knoll Hopsack	Fable CR	Eclat Weave	Eclipse	
	Delite	Ludlow	Fibra	Hologram	Glider	I
Dristi	Lyric	Greenwich	Island	Icon	Aswan	
Foil Rap	Mini Stitch	Hudson	In The Loop	Intrigue	Byron	
Heavy Metal	Night Life	Hula Hoop	Masquerade	Mod Plaid	Canaan	
Hourglass	Paradigm	Kaleidoscope CR	Menagerie	Liberty	Cato	
Mariner	Petal Pusher	Kora CR	Origins	Rivington	Cummings	
Metaphor	Pogo	Lagos	Satellite	Soon	Dynamic	
Monarch	Pop	Legend CR	Satin Chisel	Topography	Gates	
Prep	Prairie	Lore CR	Tara	Totem	Diamond Days	
Presto	Prim	Metro	Theory	Tweed Frieze	Digi Velvet	
Soliloquy	Radiance	Milestone	Woodland		Ita	
Sonnet	Ransom	Moto CR	Zoom	G	Jaipur	
Stacks	Ricochet	Noble		Arabella	Mepal	
	Roam	Palisade	E	Djenne	Olema	
B	Rush Hour	Panache CR	Highland	Gibson	Piper	
Abacus	Soiree	Quark	Ikat Square	Hampshire	Rutledge	
Argyle	Spark	Regard CR	Ikat Stripe	Haze	Sandis	
Bank Shot	Spinoff Nuance	Roundtrip	Kampala	Kamani	Vermeer	
Belize	Spree	Sandpiper	Katazome	Kinabalu	Walker	
Betwixt	Starry Night	Sequin CR	Kimono	Melange	Worth	
Bistro	Summit	Sinclair	Luberon	Sablon	Zimba	
Boundary	Sutton	Smart	Mamba	Serendipity		
Cameo	Tabloid	Spectator	Marquee	Straie Stripe		
Chroma	Venue	Spot On	Meroe	Ultrasuede		
Chronicle	Versa	Star Struck	Sherman			
Close Knit	Westwood	Stepping Stones	Tryst			
Digit	Wide Angle	Swing	Whip			
Dovetail	Zephyr	Tight Rope				
Fast Forward	Zipline	Tilden				
Ferry		Tower Grid				
	C	Transition				
	Atlas					
	Autobahn					
	Axiom					
	Baxter					
	Biota					
	Cairo					
	Charm					
	Circa					
	Classic Boucle					

Check with your KnollTextiles representative for changes or additions.

Marco Maran Gigi® Armless Chair

	description	seat h	w	d	h	textile fabric yds.	weight
Designer(s): Marco Maran, 2000 	87C Armless chair, stacking 	18"	19 3/4"	20"	34 1/4"		11 lbs.
	87C-K-N Armless chair with seat pad, non-stacking 	18"	19 3/4"	20"	34 1/4"	0.7	12 lbs.

Order Code





<i>Example:</i>	87C-K-S-010-K1207/1
87C-K-S	Gigi armless stacking chair with seat pad
010	Seafoam shell
K1207/1	Knoll Felt, Ivory

Specify:

1. Pattern number
2. Shell finish
3. Textile finish

Ordering Information

Shell finishes:

-  Black (suffix 014)
-  Graphite (suffix 003)
- Mango (suffix 006)
-  Navy (suffix 012)
-  Red (suffix 007)
- Seafoam (suffix 010)
-  White (suffix 001)

 **KnollStudio 20-Day Program:**
Gigi armless chair is available on the 20-day program, unupholstered, in white, graphite, black, red and navy shell finishes. For specific ordering information consult pages 27-28.

Upholstery/Com information:
Prices shown include fabric or leather upholstery. Contact your Knoll representative for colors. Only approved KnollTextiles and Spinneybeck leathers may be ordered.

Customer's Own Material is available pending approval. For approval requirements, processing instructions and ordering information, please see page 18.

Maintenance:

See pages 28-29.

Stacking feature:

Gigi armless unupholstered chairs stack 4 high on floor.
Gigi armless chairs with seat pad and bumper stack 4 high on floor.
Gigi armless chairs with seat pad and stacking bumper stack 8-10 high on a dolly.
Gigi arm chair with seat pad and stacking bumper stack 4 high on floor and dolly.
Gigi arm chair stacks 4 high on floor and dolly.
Gigi chairs with seatpad without bumper (87CK-N, 87AK-N) do not stack.

Note:

The Gigi Chair is Greenguard certified.

Construction

Description:

Coloured polypropylene shell on a chrome-plated base. Arm chairs have black polypropylene molded arm pads. Chair back flexes for comfort. Gigi chairs are easily cleaned in food areas and work with a booster seat.

Seat Pad:

Seat pad is permanently attached to the seat with bolts in the factory. Seat pad is not retrofittable in the field. Constructed of ABS with high resilient foam.

Stacking bumper:

Black flexible urethane stacking pad secured between base and shell.

Transportation Dolly:

Chrome plated steel frame with rubber wheels. 10 Gigi chairs can be stacked on the dolly. Dollies can stack three high for compact storage. Dolly with 10 chairs will measure 56.3" h, 19.75" w, 41" d. Dolly does not lock.

pattern no.	unuphol.	A	B	C	D	E	F	G	H	I
87C-()	\$434.									

87C-K-N-()-()		706.	721.	737.	754.	769.	780.	798.	830.	856.
-----------------	--	------	------	------	------	------	------	------	------	------

Approved KnollTextiles Grades/Fabrics

Tablet Arm:

The tablet attaches to the chair frame underneath the seat. It is aligned with the front leg and has a flip up mechanism. Tablet is black melamine. Steel support with chrome finish. Tablet arm can be used with armless chair only. Gigi with tablet can be stacked 4 high on the floor and on the dolly.

Note:

Tablet arm option is not offered with stacking bumper.





Ganging Mechanism:

The easy-to-detach ganging mechanism links two adjoining frames at the front legs or rear legs. Ganging mechanism consists of black molded polypropylene. Chairs with ganging mechanism can be stacked. Tablet arm ships separate from the chair and can be retrofitted in the field. Arm chairs can not be ganged with armless chairs.

A	Alignment Analogy Bocce Cat's Cradle Chance Common Ground Commuter Cloth Cotton Duck Delite Dristi Foil Rap Heavy Metal Hourglass Mariner Metaphor Monarch Prep Presto Soliloquy Sonnet Stacks	B	continued Gala II Grande Grandview Holbrook Journey Keaton Knoll Felt Knoll Hopsack Ludlow Lyric Mini Stitch Night Life Paradigm Petal Pusher Pogo Pop Prairie Prim Radiance Ransom Ricochet Roam Rush Hour Soiree Spark Spinoff Nuance Spree Starry Night Summit Sutton Tabloid Venue Versa Westwood Wide Angle Zephyr Zipline	C	continued Dahlia CR Decade Durand Earthwork Echo Enmesh Entourage Fable CR Fibra Greenwich Hudson Hula Hoop Kaleidoscope CR Kora CR Legend CR Lore CR Metro Milestone Moto CR Noble Palisade Panache CR Quark Regard CR Roundtrip Sandpiper Sequin CR Sinclair Smart Spectator Spot On Star Struck Stepping Stones Swing Tight Rope Tilden Tower Grid Transition	C	continued Treble CR Vibe Zari CR	D	Compass CR Coterie Eclat Weave Hologram In The Loop Island Masquerade Menagerie Origins Satellite Satin Chisel Tara Theory Woodland Zoom	E	Highland Ikat Square Ikat Stripe Kampala Katazome Kimono Luberon Mamba Marquee Meroc Sherman Tryst Whip	F	Atelier Biscayne Calais Cotton Velvet Century Coco Cornaro Eclipse Glider Icon Intrigue Mod Plaid Liberty Rivington Soon Topography Totem Tweed Frieze	G	Arabella Djenne Gibson Hampshire Haze Kamani Kinabalu Melange Sablon Serendipity Straie Stripe Ultrasuede	H	Arno Bavaria Constance Firefly Gezelle Magritte Rosemond	I	Aswan Byron Canaan Cato Cummings Dynamic Gates Diamond Days Digi Velvet Ita Jaipur Mepal Olema Piper Rutledge Sandis Vermeer Walker Worth Zimba
----------	--	----------	--	----------	--	----------	---	----------	--	----------	---	----------	---	----------	--	----------	--	----------	--

Check with your KnollTextiles representative for changes or additions.

Marco Maran Gigi® Armless Chair

	description	seat h	w	d	h	textile fabric yds.	weight
Designer(s): Marco Maran, 2000 	87C-K-S Armless chair with seat pad, stacking 	18"	19 3/4"	20"	34 1/4"	0.7	13 lbs.
	87Dolly Dolly for 10 Gigi chairs 		19.2"	31"	26 1/2"		11 lbs.
	87Tablet Folding tablet arm, right for armless chair 			9 3/4"	12"		
	87GA Gigi ganging mechanism 						

Order Code

<i>Example:</i>	87C-K-S-010-K1207/1
87C-K-S	Gigi armless stacking chair with seat pad
010	Seafoam shell
K1207/1	Knoll Felt, Ivory

Specify:

1. Pattern number
2. Shell finish
3. Textile finish

Ordering Information

Shell finishes:

- ☑ Black (suffix 014)
- ☑ Graphite (suffix 003)
- Mango (suffix 006)
- ☑ Navy (suffix 012)
- ☑ Red (suffix 007)
- Seafoam (suffix 010)
- ☑ White (suffix 001)

☑ **KnollStudio 20-Day Program:**
Gigi armless chair is available on the 20-day program, unupholstered, in white, graphite, black, red and navy shell finishes. For specific ordering information consult pages 27-28.

Upholstery/Com information:
Prices shown include fabric or leather upholstery. Contact your Knoll representative for colors. Only approved KnollTextiles and Spinneybeck leathers may be ordered.

Customer's Own Material is available pending approval. For approval requirements, processing instructions and ordering information, please see page 18.

Maintenance:

See pages 28-29.

Stacking feature:

Gigi armless unupholstered chairs stack 4 high on floor.
Gigi armless chairs with seat pad and bumper stack 4 high on floor.
Gigi armless chairs with seat pad and stacking bumper stack 8-10 high on a dolly.
Gigi arm chair with seat pad and stacking bumper stack 4 high on floor and dolly.
Gigi arm chair stacks 4 high on floor and dolly.
Gigi chairs with seatpad without bumper (87CK-N, 87AK-N) do not stack.

Note:

The Gigi Chair is Greenguard certified.

Construction

Description:

Coloured polypropylene shell on a chrome-plated base. Arm chairs have black polypropylene molded arm pads. Chair back flexes for comfort. Gigi chairs are easily cleaned in food areas and work with a booster seat.

Seat Pad:

Seat pad is permanently attached to the seat with bolts in the factory. Seat pad is not retrofittable in the field. Constructed of ABS with high resilient foam.

Stacking bumper:

Black flexible urethane stacking pad secured between base and shell.

Transportation Dolly:

Chrome plated steel frame with rubber wheels. 10 Gigi chairs can be stacked on the dolly. Dollies can stack three high for compact storage. Dolly with 10 chairs will measure 56.3" h, 19.75" w, 41" d. Dolly does not lock.

pattern no.	unuphol.	A	COM B	C	D	E	F	G	H	I
87C-K-S-(-)(-)		\$802.	\$820.	\$835.	\$853.	\$867.	\$878.	\$895.	\$929.	\$954.

87Dolly 722.

87TABLET 296.

87GA 36.

Approved KnollTextiles Grades/Fabrics

Tablet Arm:

The tablet attaches to the chair frame underneath the seat. It is aligned with the front leg and has a flip up mechanism. Tablet is black melamine. Steel support with chrome finish. Tablet arm can be used with armless chair only. Gigi with tablet can be stacked 4 high on the floor and on the dolly.

Note:

Tablet arm option is not offered with stacking bumper.

Ganging Mechanism:



The easy-to-detach ganging mechanism links two adjoining frames at the front legs or rear legs. Ganging mechanism consists of black molded polypropylene. Chairs with ganging mechanism can be stacked. Tablet arm ships separate from the chair and can be retrofitted in the field. Arm chairs can not be ganged with armless chairs.

A	Alignment Analogy Bocce Cat's Cradle Chance Common Ground Commuter Cloth Cotton Duck Delite Dristi Foil Rap Heavy Metal Hourglass Mariner Metaphor Monarch Prep Presto Soliloquy Sonnet Stacks	B	continued Gala II Grande Grandview Holbrook Journey Keaton Knoll Felt Knoll Hopsack Ludlow Lyric Mini Stitch Night Life Paradigm Petal Pusher Pogo Pop Prairie Prim Radiance Ransom Ricochet Roam Rush Hour Soiree Spark Spinoff Nuance Spree Starry Night Summit Sutton Tabloid Venue Versa Westwood Wide Angle Zephyr Zipline	C	continued Dahlia CR Decade Durand Earthwork Echo Enmesh Entourage Fable CR Fibra Greenwich Hudson Hula Hoop Kaleidoscope CR Kora CR Legend CR Lore CR Metro Milestone Moto CR Noble Palisade Panache CR Quark Regard CR Roundtrip Sandpiper Sequin CR Sinclair Smart Spectator Spot On Star Struck Stepping Stones Swing Tight Rope Tilden Tower Grid Transition	C	continued Treble CR Vibe Zari CR	D	Compass CR Coterie Eclat Weave Hologram In The Loop Island Masquerade Menagerie Origins Satellite Satin Chisel Tara Theory Woodland Zoom	E	Highland Ikat Square Ikat Stripe Kampala Katazome Kimono Luberon Mamba Marquee Meroc Sherman Tryst Whip	F	Atelier Biscayne Calais Cotton Velvet Century Coco Cornaro Eclipse Glider Icon Intrigue Mod Plaid Liberty Rivington Soon Topography Totem Tweed Frieze	G	Arabella Djenne Gibson Hampshire Haze Kamani Kinabalu Melange Sablon Serendipity Straie Stripe Ultrasuede	H	Arno Bavaria Constance Firefly Gezelle Magritte Rosemond	I	Aswan Byron Canaan Cato Cummings Dynamic Gates Diamond Days Digi Velvet Ita Jaipur Mepal Olema Piper Rutledge Sandis Vermeer Walker Worth Zimba
----------	--	----------	--	----------	--	----------	---	----------	--	----------	---	----------	---	----------	--	----------	--	----------	--

Check with your KnollTextiles representative for changes or additions.

Marco Maran

Gigi® Armless Chair with Sled Base

	description	seat h	w	d	h	textile fabric yds.	weight
Designer(s): Marco Maran, 2000 	87CSB Armless chair with sled base, stacking 	18"	21 3/8"	21"	34 1/4"	0.7	14 lbs.
	87CSB-K-N Armless chair with sled base, seat pad upholstery, non-stacking 	18"	21 3/8"	21"	34 1/4"	0.7	14 lbs.

Order Code





<i>Example:</i>	87CSB-K-N-010-K1621/21
87CSB-K-N	Gigi armless chair with sled base, non-stacking with seat pad
010	Seafoam shell
K1621/21	Classic Boucle, Smoke

Specify:

1. Pattern number
2. Shell finish
3. Textile selection

Ordering Information

Shell finishes:

-  Black (suffix 014)
-  Graphite (suffix 003)
- Mango (suffix 006)
-  Navy (suffix 012)
-  Red (suffix 007)
- Seafoam (suffix 010)
-  White (suffix 001)

Upholstery/COM information:
 Prices shown include fabric or leather upholstery. Contact your Knoll representative for colors. Only approved KnollTextiles and Spinneybeck leathers may be ordered.

Customer's Own Material is available pending approval. For approval requirements, processing instructions and ordering information, please see page 18.

Maintenance:
 See pages 28-28.

Stacking feature:
 Gigi with sled base, armless, unupholstered stack 4 high on floor.
 Gigi with sled base, armless, unupholstered stack 8-10 high on dolly.
 Gigi with sled base, armless, seat pad upholstery with stacking bumper stack 4 high on floor.
 Gigi with sled base, armless, seat pad upholstery with stacking bumper stack 8-10 high on dolly.

Construction

Description:
 Coloured polypropylene shell on a chrome-plated base. Arm chairs have black polypropylene molded arm pads. Chair back flexes for comfort. Gigi chairs are easily cleaned in food areas and work with a booster seat.

Seat Pad:
 Seat pad is permanently attached to the seat with bolts in the factory. Seat pad is not retrofittable in the field. Constructed of ABS with high resilient foam.

Stacking bumper:
 Black flexible urethane stacking pad secured between base and shell.

Transportation Dolly:
 Chrome plated steel frame with rubber wheels. 10 Gigi chairs can be stacked on the dolly. Dollies can stack three high for compact storage. Dolly with 10 chairs will measure 56.3" h, 19.75" w, 41" d. Dolly does not lock.

pattern no.	unuphol.	A	B	C	D	E	F	G	H	I
87CSB-()	\$598.									

87CSB-K-N-()-()	868.	885.	902.	918.	933.	943.	961.	994.	1,020.
-------------------	------	------	------	------	------	------	------	------	--------



Approved KnollTextiles Grades/Fabrics

A	Alignment Analogy Bocce Cat's Cradle Chance Common Ground Commuter Cloth Cotton Duck Delite Dristi Foil Rap Heavy Metal Hourglass Mariner Metaphor Monarch Prep Presto Soliloquy Sonnet Stacks	B	Gala II Grande Grandview Holbrook Journey Keaton Knoll Felt Knoll Hopsack Ludlow Lyric Mini Stitch Night Life Paradigm Petal Pusher Pogo Pop Prairie Prim Radiance Ransom Ricochet Roam Rush Hour Soiree Spark Spinoff Nuance Spree Starry Night Summit Sutton Tabloid Venue Versa Westwood Wide Angle Zephyr Zipline	C	continued Dahlia CR Decade Durand Earthwork Echo Enmesh Entourage Fable CR Fibra Greenwich Hudson Hula Hoop Kaleidoscope CR Kora CR Lagos Legend CR Lore CR Metro Milestone Moto CR Noble Palisade Panache CR Quark Regard CR Roundtrip Sandpiper Sequin CR Sinclair Smart Spectator Spot On Star Struck Stepping Stones Swing Tight Rope Tilden Tower Grid Transition	C	continued Treble CR Vibe Zari CR	D	Compass CR Coterie Eclat Weave Hologram In The Loop Island Masquerade Menagerie Origins Satellite Satin Chisel Tara Theory Woodland Zoom	E	Highland Ikat Square Ikat Stripe Kampala Katazome Kimono Luberon Mamba Marquee Meroc Sherman Tryst Whip	F	Atelier Biscayne Calais Cotton Velvet Century Coco Cornaro Eclipse Glider Icon Intrigue Mod Plaid Liberty Rivington Soon Topography Totem Tweed Frieze	G	Arabella Djenne Gibson Hampshire Haze Kamani Kinabalu Melange Sablon Serendipity Straie Stripe Ultrasuede	H	Arno Bavaria Constance Firefly Gezelle Magritte Rosemond	I	Aswan Byron Canaan Cato Cummings Dynamic Gates Diamond Days Digi Velvet Ita Jaipur Mepal Olema Piper Rutledge Sandis Vermeer Walker Worth Zimba
----------	--	----------	---	----------	---	----------	---	----------	--	----------	---	----------	---	----------	--	----------	--	----------	--

Check with your KnollTextiles representative for changes or additions.

Marco Maran

Gigi® Armless Chair with Sled Base

	description	height, seat	width	depth	height	textile fabric yds.	weight
<p><i>Designer(s):</i> Marco Maran, 2000</p> 	<p>87CSB-K-S Armless chair with sled base, seat pad upholstery, stacking</p> 	18"	21 3/8"	21"	34 1/4"	0.7	14 lbs.
	<p>87Dolly Dolly for 10 Gigi chairs</p> 		19.2"	31"	26 1/2"		11 lbs.

Order Code

Example: **87CSB-K-N-010-K1621/21**





87CSB-K-N	Gigi armless chair with sled base, non-stacking with seat pad
010	Seafoam shell
K1621/21	Classic Boucle, Smoke

Specify:

1. Pattern number
2. Shell finish
3. Textile selection

Ordering Information

Shell finishes:

-  Black (suffix 014)
-  Graphite (suffix 003)
- Mango (suffix 006)
-  Navy (suffix 012)
-  Red (suffix 007)
- Seafoam (suffix 010)
-  White (suffix 001)

Upholstery/COM information:

Prices shown include fabric or leather upholstery. Contact your Knoll representative for colors. Only approved KnollTextiles and Spinneybeck leathers may be ordered.

Customer's Own Material is available pending approval. For approval requirements, processing instructions and ordering information, please see page 18.

Maintenance:

See pages 28-28.

Stacking feature:

Gigi with sled base, armless, unupholstered stack 4 high on floor.
Gigi with sled base, armless, unupholstered stack 8-10 high on dolly.
Gigi with sled base, armless, seat pad upholstery with stacking bumper stack 4 high on floor.
Gigi with sled base, armless, seat pad upholstery with stacking bumper stack 8-10 high on dolly.

Construction

Description:

Coloured polypropylene shell on a chrome-plated base. Arm chairs have black polypropylene molded arm pads. Chair back flexes for comfort. Gigi chairs are easily cleaned in food areas and work with a booster seat.

Seat Pad:

Seat pad is permanently attached to the seat with bolts in the factory. Seat pad is not retrofittable in the field. Constructed of ABS with high resilient foam.

Stacking bumper:

Black flexible urethane stacking pad secured between base and shell.

Transportation Dolly:

Chrome plated steel frame with rubber wheels. 10 Gigi chairs can be stacked on the dolly. Dollies can stack three high for compact storage. Dolly with 10 chairs will measure 56.3" h, 19.75" w, 41" d. Dolly does not lock.

pattern no.	unuphol.	A	B	C	D	E	F	G	H	I
87CSB-K-S-()-()		\$966.	\$984.	\$998.	\$1,017.	\$1,030.	\$1,040.	\$1,059.	\$1,093.	\$1,117.

87Dolly 722.

Approved KnollTextiles Grades/Fabrics

A	Alignment Analogy Bocce Cat's Cradle Chance Common Ground Commuter Cloth Cotton Duck Delite Dristi Foil Rap Heavy Metal Hourglass Mariner Metaphor Monarch Prep Presto Soliloquy Sonnet Stacks	B	Gala II Grande Grandview Holbrook Journey Keaton Knoll Felt Knoll Hopsack Ludlow Lyric Mini Stitch Night Life Paradigm Petal Pusher Pogo Pop Prairie Prim Radiance Ransom Ricochet Roam Rush Hour Soiree Spark Spinoff Nuance Spree Starry Night Summit Sutton Tabloid Venue Versa Westwood Wide Angle Zephyr Zipline	C	continued Dahlia CR Decade Durand Earthwork Echo Enmesh Entourage Fable CR Fibra Greenwich Hudson Hula Hoop Kaleidoscope CR Kora CR Lagos Legend CR Lore CR Metro Milestone Moto CR Noble Palisade Panache CR Quark Regard CR Roundtrip Sandpiper Sequin CR Sinclair Smart Spectator Spot On Star Struck Stepping Stones Swing Tight Rope Tilden Tower Grid Transition	C	continued Treble CR Vibe Zari CR	D	Compass CR Coterie Eclat Weave Hologram In The Loop Island Masquerade Menagerie Origins Satellite Satin Chisel Tara Theory Woodland Zoom	E	Highland Ikat Square Ikat Stripe Kampala Katazome Kimono Luberon Mamba Marquee Meroc Sherman Tryst Whip	F	Atelier Biscayne Calais Cotton Velvet Century Coco Cornaro Eclipse Glider Icon Intrigue Mod Plaid Liberty Rivington Soon Topography Totem Tweed Frieze	G	Arabella Djenne Gibson Hampshire Haze Kamani Kinabalu Melange Sablon Serendipity Straie Stripe Ultrasuede	H	Arno Bavaria Constance Firefly Gezelle Magritte Rosemond	I	Aswan Byron Canaan Cato Cummings Dynamic Gates Diamond Days Digi Velvet Ita Jaipur Mepal Olema Piper Rutledge Sandis Vermeer Walker Worth Zimba
----------	--	----------	---	----------	---	----------	---	----------	--	----------	---	----------	---	----------	--	----------	--	----------	--





Check with your KnollTextiles representative for changes or additions.

Marco Maran

Gigi® Barstool and Swivel Chair

Designer(s):
Marco Maran, 2002



description	seat h, min	seat h, max	arm h, min	arm h, max	w	d	h, min	h, max	weight
87CS Gigi armless swivel chair 	17 1/4"	22 1/2"			22 9/10"	25"	33 1/2"	38 1/4"	17 lbs.
87AS Gigi arm swivel chair 	17 1/4"	22 1/2"	24 3/4"	29 1/4"	22 9/10"	25"	33 1/2"	38 1/4"	21 lbs.
87CM Gigi barstool, counter-height 		24"			19 3/4"	20"		40 1/2"	14 lbs.
87CH Gigi barstool, bar-height 		29 1/2"			19 3/4"	20"		46"	15 lbs.

Order Code





Example: **87AS-006**
87AS Gigi arm swivel chair
006 Mango shell

Specify:

1. Pattern number
2. Shell finish

Ordering Information

Shell Finishes:

-  Black (suffix 014)
-  Graphite (suffix 003)
- Mango (suffix 006)
-  Navy (suffix 012)
-  Red (suffix 007)
- Seafoam (suffix 010)
-  White (suffix 001)

KnollStudio 20-Day Program:

Gigi arm and armless swivel chair and counter and bar-height barstools are available on the 20-day program, upholstered, in white, graphite, black, red and navy shell finishes. For specific ordering information consult pages 27-28.

Maintenance:

See pages 28-29.

Note:

The Gigi Stool and Swivel Chair are Greenguard certified.

Construction

Description:

Coloured polypropylene and 15% fiberglass shell on a chrome-plated base. Arm chairs have black polypropylene molded arm pads. Chair back flexes for comfort. Gigi chairs are easily cleaned in food service areas.

Swivel:

Swivel mechanism with pneumatic seat height adjustment T-section polished aluminum base, with hard black casters. Colored polypropylene shell on a chrome-plated base. Armchairs have black polypropylene molded arm pads.

pattern no.

87CS-()	\$1,177.
----------------	----------





87AS-()	1,365.
----------------	--------

87CM-()	833.
----------------	------

87CH-()	833.
----------------	------

Marco Maran

X3 Chair and Barstool

	description	seat h	w	d	h	weight
<p><i>Designer(s):</i> Marco Maran, 2005</p> 	<p>78 X3 Stacking chair</p> 	17 1/4"	20 1/2"	19"	30 1/4"	16 lbs.
	<p>78CM X3 Barstool, counter-height</p> 	24 1/2"	20 1/2"	19"	37 1/2"	19 lbs.
	<p>78CH X3 Barstool, bar-height</p> 	29 1/2"	20 1/2"	19"	42 1/2"	20 lbs.
	X3Dolly Dolly for 15 X3 chairs		19.2"	31"	26 1/2"	10 lbs.

Order Code

<i>Example:</i>	78-OR-C
78	X3 Stacking chair
OR	Tangerine shell
C	Chrome base

Specify:

1. Pattern number
2. Finish option
3. Chrome base

Ordering Information

Finishes:
 Clear Gray (suffix GR)
 Lime (suffix GE)
 Sapphire (suffix BU)
 Tangerine (suffix OR)

Maintenance:
 Clean with mild soap and water only. Do not use chemical cleaners such as Windex or Fantastik.

Note:
 The X3 Collection is Greenguard certified.

Construction

Frame:
 Sled base constructed of chrome-plated steel. Base is polished chrome finish.

Shell:
 One piece seat shell, constructed by the bi-injection of transparent polycarbonate and a Desmopan lattice.

pattern no.

78-()-C	\$824.
-----------------	--------

78CM-()-C	1,353.
-------------------	--------

78CH-()-C	1,353.
-------------------	--------

87DOLLY	722.
----------------	------

Stackability:

Chair stacks 8 on the floor. Barstool does not stack.

Glides:

4 white nylon glides included with the chair.

Transportation Dolly:

Dolly is chrome plated steel with rubber wheels. 8 chairs stack on the dolly.

Ludwig Mies van der Rohe

Tubular Brno Chair

description	frame	seat	arm	w	d	h	textile	req.	weight
		h	h				fabric	leather	
		yds.	sq. ft.						
245A Brno Tugendhat arm chair - tubular frame, with thin seat and back	polished chrome	17 1/4"	25 3/4"	22 3/4"	22 1/2"	31 1/2"	1.7	28	23 lbs.
	stainless steel	17 1/4"	25 3/4"	22 3/4"	22 1/2"	31 1/2"	1.7	28	24 lbs.
245AT Brno Classic arm chair - tubular frame, with thick seat and back	polished chrome	17 1/4"	25 3/4"	22 3/4"	22 1/2"	31 1/2"	1.7	28	23 lbs.
	stainless steel	17 1/4"	25 3/4"	22 3/4"	22 1/2"	31 1/2"	1.7	28	24 lbs.
G Glides (add -G to end of pattern number)									
P Perforated leather option (add P to end of pattern number and suffix -PERF to leather selection)								30	

Designer(s):
Ludwig Mies van der Rohe, 1930
Design from the Mies van der Rohe Archive of The Museum of Modern Art

Award(s):
The Museum of Modern Art, New York, USA, 1977



Order Code

<i>Example:</i>	245A-S-P-VO906-PERF
245A	Tubular arm chair, thin seat
S	Stainless Steel
P	Perforated leather
VO906-PERF	Volo, Navy, perforated

Note:
The Tubular and Flat Bar Brno chairs are part of a collection. Please refer to Mies side chairs and lounge seating beginning on page 182 and tables, beginning on page 346.

Specify:

1. Pattern number
2. Glide option
3. Cal 133 Fire Code option
4. Perforated leather option
5. Textile selection

Ordering Information

Finishes:
Polished Chrome (suffix C)
Stainless Steel (suffix S)

Upholstery/COM information:
Prices shown include fabric or leather upholstery. Contact your Knoll representative for colors. Only approved KnollTextiles and Spinneybeck leathers may be ordered.

Customer's Own Material is available pending approval. For approval requirements, processing instructions and ordering information please see page 18.

Woven leather option:
The Tubular Brno Chairs can be upholstered in woven leather as a COL. 30 sq. ft. of woven leather required. Specify suffix -W after pattern number.

Perforated leather option:
The Tubular Brno Chairs are available in perforated leather upholstery. Specify suffix -P at end of pattern number and suffix -PERF at end of leather selection. 30 sq. ft. of leather required.

Cal 133 Fire Code # :
The Tubular Brno Chairs comply with the California Technical Bulletin 133 standard if upholstered in Cal 133 approved upholstery. Specify suffix -C at end of pattern number and suffix -133 at end of textile selection. Upcharge applies, see page 19.

Maintenance:
See pages 28-29.

Note:
The KnollStudio logo and signature of Ludwig Mies van der Rohe are stamped into the frame of the chair under the arm.

The Tubular Bar Brno Chair is Greenguard certified.

Construction

Frame:
Stainless steel:
Tubular pre-stressed, pre-buffed 14 gauge stainless steel. Clean, seamless joints and hidden drilled or countersunk holes (as opposed to punched) render the chair free of deformation.

Polished chrome:
11 gauge steel. The mirror chrome-plating process includes lengthy nickel and silicone coatings for rust protection and increased durability. All chairs are polished to a mirror finish. Clean, seamless joints and hidden drilled or countersunk holes (as opposed to punched) render the chair free of deformation.

Upholstery:
Inner hardwood frame cushioned with variable density foam. Dymetrol seat suspension enhances comfort level. Replacement seat and backs are not available on Brno chairs. Tubular Brno with thin seat (245A, 245AS) has no welt detail. Tubular Brno with thick seat (245AT, 245AB) has welt detail on underside of seat.

Optional glides:
Six clear plastic glides in specially drilled holes.

pattern no.	grades										COL			
	A	B	C	D	E	F	G	H	I	U	V	W	X	Y
245A-C	\$2,160.	\$2,227.	\$2,291.	\$2,339.	\$2,382.	\$2,422.	\$2,465.	\$2,574.	\$2,767.	\$2,990.	\$3,208.	\$3,640.	\$3,746.	\$3,840.
245A-S	2,794.	2,861.	2,925.	2,973.	3,016.	3,055.	3,099.	3,208.	3,400.	3,624.	3,841.	4,275.	4,381.	4,472.

245AT-C	2,473.	2,538.	2,604.	2,653.	2,693.	2,734.	2,777.	2,885.	3,079.	3,301.	3,517.	3,953.	4,059.	4,150.
245AT-S	3,095.	3,159.	3,224.	3,274.	3,316.	3,356.	3,398.	3,506.	3,701.	3,923.	4,139.	4,575.	4,681.	4,773.

G	28.
P	876.

Approved KnollTextiles Grades/Fabrics

A	Alignment ‡ Analogy Beacon Bocce Cat's Cradle Chance Common Ground ‡ Commuter Cloth ‡ Cotton Duck Delite Dristi Foil Rap Hourglass Heavy Metal Mariner Metaphor Monarch ‡ Prep ‡ Presto ‡ Soliloquy Sonnet Stacks Trophy	B continued Digit Digital Tape Dovetail ‡ Fast Forward Ferry Forza Gala II Grande Grandview Holbrook Journey Keaton Knoll Felt Knoll Hopsack Ludlow Lyric Mini Stitch ‡ Night Life Nonchalant CR Paradigm Petal Pusher Pogo ‡ Pop Prairie Prim ‡ Prompt Radiance Ransom Ricochet ‡ Roam Rush Hour Soiree Spark ‡ Spinoff Nuance ‡ Spree Starry Night ‡ Summit Sutton Synth Tabloid Venue Versa Vinyl Westwood Wide Angle ‡ Zephyr Zipline	C Atlas Autobahn Axiom Baxter Biota ‡ Cairo Charm Circa Classic Boucle Dahlia CR Decade Dune Durand Earthwork ‡ Echo Empire Stripe Enmesh Entourage Fable CR Fibra Greenwich Hudson Hula Hoop Kaleidoscope CR Kora CR Lagos Legend CR Lore CR Magnolia Metro Milestone Moto CR Noble Palisade Panache CR Posh Quark Regard CR Roundtrip Sahara Sandpiper Sequin CR	C continued Sinclair Smart Spectator Spot On Star Struck Stepping Stones Swing Tight Rope Tilden Tower Grid Transition ‡ Treble CR Vibe Zari CR	D Compass CR Coterie Eclat Weave Hologram In The Loop Island Masquerade Menagerie Origins Satellite Satin Chisel Tara Theory Woodland Zoom	E Highland Ikat Square Ikat Stripe Kampala Katazome Kimono Luberon Mamba Marquee Meroe Sherman Shima Tryst Whip
----------	--	---	---	--	--	--

Spinneybeck Leather



U Vicenza ‡ Volo ‡	V Acqua ‡ Andes ‡ Embossed Tipped España ‡ Hand Tipped Maremma Velluto Pelle ‡	W Alaska ‡ Amazon ‡ Antique ‡ Arizona ‡ Derby ‡ Forte ‡ Lucente Sabrina ‡	X Ducale ‡ Ducale Velour ‡	Y Capri ‡ Cervo Copenhagen ‡ Cordovan ‡ Distressed Lucca Marissa ‡ Portofino Prima ‡ Riva ‡ Saddle ‡ Salon ‡ Torello
---------------------------------	--	--	---	--

‡ Approved for Cal 133 upholstery.

Check with your KnollTextiles or Spinneybeck Representative for changes or additions.

Ludwig Mies van der Rohe

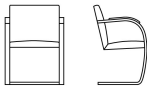
Flat Bar Brno Chair

description	frame	seat	arm	w	d	h	textile	req.	weight	
		h	h				fabric	leather		
<i>Designer(s):</i> Ludwig Mies van der Rohe, 1930	255A Brno arm chair, flat bar frame, with armpads	polished chrome	17 1/2"	25 3/4"	22 3/4"	22 1/2"	31 1/2"	1.7	28	37 lbs.
		stainless steel	17 1/2"	25 3/4"	22 3/4"	22 1/2"	31 1/2"	1.7	28	38 lbs.
<i>Award(s):</i> The Museum of Modern Art, New York, USA, 1977		polished chrome	17 1/2"	25 3/4"	22 3/4"	22 1/2"	31 1/2"	1.7	28	37 lbs.
		stainless steel	17 1/2"	25 3/4"	22 3/4"	22 1/2"	31 1/2"	1.7	28	38 lbs.
	255C Brno arm chair, flat bar frame, without armpads	polished chrome	17 1/2"	25 3/4"	22 3/4"	22 1/2"	31 1/2"	1.7	28	37 lbs.
		stainless steel	17 1/2"	25 3/4"	22 3/4"	22 1/2"	31 1/2"	1.7	28	38 lbs.
		P Perforated leather option (add P to end of pattern number and suffix -PERF to leather selection)								30
		G Glides (add -G to end of pattern number)								

Order Code

<i>Example:</i>	255A-S-DL301
255A	Flat bar arm chair, with armpads
S	Stainless Steel
DL301	Ducale, Aqua

Note:

The Tubular and Flat Bar Brno chairs are part of a collection. Please refer to Mies side chairs and lounge seating, beginning on page 182 and tables, beginning on page 346.

Specify:

1. Pattern number
2. Glide option
3. Cal 133 Fire Code option
4. Textile selection

Ordering Information

Finishes:
Polished Chrome (suffix C)
Stainless Steel (suffix S)

Upholstery/COM information:
Prices shown include fabric or leather upholstery. Contact your Knoll representative for colors. Only approved KnollTextiles and Spinneybeck leathers may be ordered.

Customer's Own Material is available pending approval. For approval requirements, processing instructions and ordering information please see page 18.

Woven leather option:
The 255CS Flat Bar Brno Chair without armpads can be upholstered in woven leather COL. 30 sq. ft. of woven leather required. Specify suffix -W after pattern number.

Perforated leather option:
The Flat Bar Brno Chairs without pads are available in perforated leather upholstery. Specify suffix -P at end of pattern number and suffix -PERF at end of leather selection. 30 sq. ft. of leather required.

Cal 133 Fire Code #:
The Flat Bar Brno Chairs comply with the California Technical Bulletin 133 standard if upholstered in Cal 133 approved upholstery. Specify suffix -C at end of pattern number and suffix -133 at end of textile selection. Upcharge applies, see page 19.

Maintenance:
See pages 28-29.

Note:
The KnollStudio logo and signature of Ludwig Mies van der Rohe are stamped into the frame under the arm of the chair.

The Flat Bar Brno Chair is Greenguard certified.

Construction

Frame:
Stainless steel:
Stainless steel frame is 304 bar stock stainless steel. Frame is hand-grained and hand-buffed to mirror finish. No visible connections between seat and frame. Seat and back constructed of durable hardwood.

Polished chrome:
Frame is chrome-plated on steel frame. Available with or without arm pads.

Upholstery:
Inner hardwood frame cushioned with variable density foam. Dymetrol seat suspension enhances comfort level. Replacement seat and backs are not available on Brno chairs. Flat Bar Brno Chair with and without armpads has welt detail on underside of seat and outside of back. Optional armpads have welt around perimeter.

Optional glides:
Four charcoal-colored nylon glides recessed in base of frame.

pattern no.	grades													
	A	B	C	D	E	F	G	H	I	U	V	W	X	Y
255A-C	\$3,079.	\$3,150.	\$3,217.	\$3,265.	\$3,309.	\$3,349.	\$3,394.	\$3,503.	\$3,703.	\$3,928.	\$4,146.	\$4,592.	\$4,699.	\$4,796.
255A-S	4,609.	4,680.	4,746.	4,797.	4,839.	4,880.	4,922.	5,032.	5,233.	5,459.	5,678.	6,123.	6,229.	6,324.

255C-C	2,777.	2,843.	2,907.	2,958.	3,003.	3,041.	3,082.	3,189.	3,388.	3,610.	3,824.	4,259.	4,365.	4,457.
255C-S	4,284.	4,352.	4,416.	4,466.	4,512.	4,550.	4,590.	4,697.	4,895.	5,118.	5,332.	5,768.	5,874.	5,964.

P 876.

G 28.

Approved KnollTextiles Grades/Fabrics

A	Alignment ‡ Analogy Beacon Bocce Cat's Cradle Chance Common Ground ‡ Commuter Cloth ‡ Cotton Duck Delite Dristi Foil Rap Hourglass Heavy Metal Mariner Metaphor Monarch ‡ Prep ‡ Presto ‡ Soliloquy Sonnet Stacks Trophy	B continued Digit Digital Tape Dovetail ‡ Fast Forward Ferry Forza Gala II Grande Grandview Holbrook Journey Keaton Knoll Felt Knoll Hopsack Ludlow Lyric Mini Stitch ‡ Night Life Nonchalant CR Paradigm Petal Pusher Pogo ‡ Pop Prairie Prim ‡ Prompt Radiance Ransom Ricochet ‡ Roam Rush Hour Soiree Spark ‡ Spinoff Nuance ‡ Spree Starry Night ‡ Summit Sutton Synth Tabloid Venue Versa Vinyl Westwood Wide Angle ‡ Zephyr Zipline	C Atlas Autobahn Axiom Baxter Biota ‡ Cairo Charm Circa Classic Boucle Dahlia CR Decade Dune Durand Earthwork ‡ Echo Empire Stripe Enmesh Entourage Fable CR Fibra Greenwich Hudson Hula Hoop Kaleidoscope CR Kora CR Lagos Legend CR Lore CR Magnolia Metro Milestone Moto CR Noble Palisade Panache CR Posh Quark Regard CR Roundtrip Sahara Sandpiper Sequin CR	C continued Sinclair Smart Spectator Spot On Star Struck Stepping Stones Swing Tight Rope Tilden Tower Grid Transition ‡ Treble CR Vibe Zari CR	D Compass CR Coterie Eclat Weave Hologram In The Loop Island Masquerade Menagerie Origins Satellite Satin Chisel Tara Theory Woodland Zoom	E Highland Ikat Square Ikat Stripe Kampala Katazome Kimono Luberon Mamba Marquee Meroe Sherman Shima Tryst Whip
----------	--	---	---	--	--	--

Spinneybeck Leather

U Vicenza ‡ Volo ‡	V Acqua ‡ Andes ‡ Embossed Tipped España ‡ Hand Tipped * Maremma Velluto Pelle ‡	W Alaska ‡ Amazon ‡ Antique ‡ Arizona ‡ Derby * ‡ Forte ‡ Lucente Sabrina ‡	X Ducale * ‡ Ducale Velour * ‡	Y Capri ‡ Cervo Copenhagen * Cordovan ‡ Distressed * Lucca Marissa ‡ Portofino * Prima ‡ Riva ‡ Saddle * ‡ Salon * ‡ Torello
---------------------------------	--	--	---	--

‡ Approved for Cal 133 upholstery.
* Not approved for 255AS armpad version

Check with your KnollTextiles or Spinneybeck Representative for changes or additions.

Ludwig Mies van der Rohe

Four Seasons Stool

	description	w	d	seat h	textile fabric yds.	req. leather sq. ft.	weight
<i>Designer(s):</i> Ludwig Mies van der Rohe, 1958	257C Four Seasons Stool	17"	17"	30"	0.8	15	24 lbs.

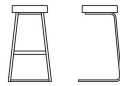

Order Code

<i>Example:</i>	257C-DV116
257C	Four Seasons Stool
DV116	Ducale Velour, Lava

Specify:

1. Pattern number
2. Textile selection

Ordering Information

Upholstery/COM information:
Prices shown include fabric or leather upholstery. Contact your Knoll representative for colors. Only approved KnollTextiles and Spinneybeck leathers may be ordered.

Customer's Own Material is available pending approval. For approval requirements, processing instructions and ordering information please see page 18.

Maintenance:
See pages 28-29.

Note:
The KnollStudio logo and signature of Ludwig Mies van der Rohe are stamped into the base of the stool.

Cal 133 Fire Code#:
The Four Seasons Stools comply with the California Technical Bulletin 133 standard if upholstered in Cal 133 approved upholstery. Specify suffix -C at end of pattern number and suffix -133 at end of textile selection. Upcharge applies, see page 19.

The Four Season Stool is Greenguard certified.

Construction

Frame:
Bent steel frame with chrome plating.

Upholstery:
Seat upholstered in leather or fabric over foam cushion reinforced with a plywood form.

Stitching:
Stitching detail is found on the rear left hand corner of the stool.

pattern no.	grades	COM	C	D	E	F	G	H	I	COL	V	W	X	Y
	A	B								U				
257C(-)	\$3,286.	\$3,308.	\$3,329.	\$3,351.	\$3,369.	\$3,383.	\$3,405.	\$3,452.	\$3,482.	\$3,601.	\$3,683.	\$3,849.	\$3,885.	\$3,925.

Approved KnollTextiles Grades/Fabrics

A	Alignment ‡ Analogy Beacon Bocce Cat's Cradle Chance Common Ground ‡ Commuter Cloth ‡ Cotton Duck Delite Dristi Foil Rap Hourglass Heavy Metal Mariner Metaphor Monarch ‡ Prep ‡ Presto ‡ Soliloquy Sonnet Stacks Trophy	B	Abacus ‡ Argyle Backdrop Bank Shot Belize Betwixt Bistro ‡ Boundary ‡ Cameo Chroma ‡ Chronicle Close Knit	E continued	Digit Digital Tape Dovetail ‡ Fast Forward Ferry Forza Gala II Grande Grandview Holbrook Journey Keaton Knoll Felt Knoll Hopsack Ludlow Lyric Mini Stitch ‡ Night Life Nonchalant CR Paradigm Petal Pusher Pogo ‡ Pop Prairie Prim ‡ Prompt Radiance Ransom Ricochet ‡ Roam Rush Hour Soiree Spark ‡ Spinoff Nuance ‡ Spree Starry Night ‡ Summit Sutton Synth Tabloid Venue Versa Vinyl Westwood Wide Angle ‡ Zephyr Zipline	C	Atlas Autobahn Axiom Baxter Biota ‡ Cairo Charm Circa Classic Boucle Dahlia CR Decade Dune Durand Earthwork ‡ Echo Empire Stripe Enmesh Entourage Fable CR Fibra Greenwich Hudson Hula Hoop Kaleidoscope CR Kora CR Lagos Legend CR Lore CR Magnolia Metro Milestone Moto CR Noble Palisade Panache CR Posh Quark Regard CR Roundtrip Sahara Sandpiper Sequin CR	C continued	Sinclair Smart Spectator Spot On Star Struck Stepping Stones Swing Tight Rope Tilden Tower Grid Transition ‡ Treble CR Vibe Zari CR	D	Compass CR Coterie Eclat Weave Hologram In The Loop Island Masquerade Menagerie Origins Satellite Satin Chisel Tara Theory Woodland Zoom	E	Highland Ikat Square Ikat Stripe Kampala Katazome Kimono Luberon Mamba Marquee Meroe Sherman Shima Tryst Whip	F	Atelier Biscayne Calais Cotton Velvet Century Coco Cornaro Eclipse Glider Icon Intrigue Liberty Mod Plaid Rivington Soon Topography Totem Tweed Frieze	G	Arabella Arber Djenne Gibson Hampshire Haze Kamani Kinabalu Kingston Melange Metallic Gloss Sablon Serendipity Spencer Straie Stripe Ultrasuede Utrillo	H	Arno Bavaria Constance Firefly Gezelle Magritte Rosemond	I	Aswan Byron Canaan Cato Cummings Diamond Days Digi Velvet Dynamic Gates Ita Jaipur Knoll Velvet Mepal North Island Olema Piper Ravello Rutledge Sandis Tudor Vermeer Walker Worth Zimba	U	Vicenza ‡ Volo ‡	V	Acqua ‡ Andes ‡ Embossed Tipped ‡ España ‡ Hand Tipped ‡ Velluto Pelle ‡	W	Alaska ‡ Amazon ‡ Antique ‡ Arizona ‡ Derby ‡ Forte ‡ Lucente Sabrina ‡	X	Ducale Ducale Velour	Y	Capri ‡ Cervo Copenhagen Cordovan ‡ Distressed Lucca Marissa ‡ Portofino Prima ‡ Riva ‡ Saddle ‡ Salon
----------	--	----------	--	--------------------	---	----------	---	--------------------	--	----------	--	----------	--	----------	---	----------	---	----------	--	----------	--	----------	---------------------	----------	---	----------	--	----------	-------------------------	----------	---



Spinneybeck Leather

U	Vicenza ‡ Volo ‡	V	Acqua ‡ Andes ‡ Embossed Tipped ‡ España ‡ Hand Tipped ‡ Velluto Pelle ‡	W	Alaska ‡ Amazon ‡ Antique ‡ Arizona ‡ Derby ‡ Forte ‡ Lucente Sabrina ‡	X	Ducale Ducale Velour	Y	Capri ‡ Cervo Copenhagen Cordovan ‡ Distressed Lucca Marissa ‡ Portofino Prima ‡ Riva ‡ Saddle ‡ Salon
----------	---------------------	----------	---	----------	--	----------	-------------------------	----------	---

Check with your KnollTextiles or Spinneybeck Representative for changes or additions.

Ludwig Mies van der Rohe

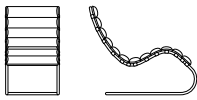
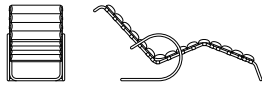
MR Lounge Seating

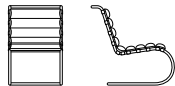
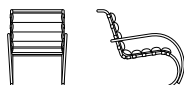
	description	frame	seat h	arm h	w	d	h	req. leather sq. ft.	weight
<i>Designer(s):</i> Mies van der Rohe, 1929 Design from the Mies van der Rohe Archive of The Museum of Modern Art	241LS MR chaise lounge 	Cowhide straps			23 1/2"	47 1/4"	37 1/2"	72	39 lbs.
		Sandwiched straps			23 1/2"	47 1/4"	37 1/2"	106	39 lbs.
<i>Award(s):</i> The Museum of Modern Art, New York, USA; Design Center Stuttgart Award, W. Germany, 1978	242LS MR adjustable chaise lounge 	Cowhide straps		19 1/2"	25 1/2"	70 1/4"	31 3/4"	91	43 lbs.
		Sandwiched straps		19 1/2"	25 1/2"	70 1/4"	31 3/4"	133	43 lbs.
	247LS MR armless lounge chair 	Cowhide straps	15 3/4"		23 1/2"	34 3/4"	33"	50	24 lbs.
		Sandwiched straps	15 3/4"		23 1/2"	34 3/4"	33"	75	24 lbs.
	248LS MR lounge chair with arms 	Cowhide straps	15 3/4"	23"	25 1/2"	36 1/4"	33"	50	32 lbs.
		Sandwiched straps	15 3/4"	23"	25 1/2"	36 1/4"	33"	75	32 lbs.

Order Code

<i>Example:</i>	241LS-H01-VP03
241LS	Chaise lounge
H01	Black cowhide straps
VP03	Velluto Pelle, Espresso
<i>Example:</i>	242LS-DE221-DE221
242LS	Chaise lounge
DE221	Sandwiched Derby straps, Brick
DE221	Derby, Brick

Note:
The Mies lounge chairs are part of a collection. Please refer to Mies side chairs and lounge seating beginning on page 182, and tables, beginning on page 346.

Specify:

1. Pattern number
2. Strap selection
3. Textile selection

Ordering Information

Strap selection:
Cowhide belting frame supports to match the following colors:
Black (suffix H01)

For colors other than black, leather selected is sandwiched to belting thickness on cowhide backing. Select any approved Spinneybeck leather and color.

Upholstery note:
Prices shown include leather upholstery and strap selection. **No Customer's Own Material can be used.**

Note:
The MR Lounge Seating is Greenguard certified.

Construction

Frame:
Seamless tubular stainless steel with a polished finish. Glides not included.

Upholstery straps:
Black cowhide belting straps with front, back, and sides all stained. For all other colors, upholstery is sandwiched to belting thickness on both front and back, with sides left natural. Cowhide backing. 241LS contains 12 belting support straps; 242LS contains 15 straps; 247LS and 248LS contain 9 straps each.

Upholstery:
Leather is crafted in a series of quilted and seamed cushion sections.

pattern no.	U	V	W	X	Y
241LS-(H01)	\$13,178.	\$13,731.	\$14,858.	\$15,093.	\$15,367.
241LS-()	14,315.	15,128.	16,784.	17,130.	17,534.
242LS-(H01)	16,131.	16,831.	18,257.	18,551.	18,894.
242LS-()	17,535.	18,555.	20,635.	21,068.	21,572.
247LS-(H01)	8,724.	9,111.	9,893.	10,052.	10,244.
247LS-()	9,559.	10,135.	11,308.	11,554.	11,837.
248LS-(H01)	10,181.	10,566.	11,344.	11,507.	11,698.
248LS-()	11,014.	11,589.	12,762.	13,009.	13,292.

Spinneybeck Leather

U Vicenza Volo	X Ducale Ducale Velours
V Acqua Andes Embossed Tipped España Hand Tipped Velluto Pelle	Y Capri Cervo Copenhagen Cordovan Distressed Lucca Marissa Portofino
W Alaska Amazon Antique Arizona Derby Forte Lucente Sabrina	Prima Riva Saddle Salon Torello

*Check with your Spinneybeck
Representative for changes or additions.*

Ludwig Mies van der Rohe

MR Chair

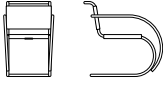
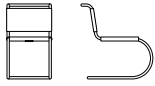
	description	seat h	arm h	w	d	h	weight
<p><i>Designer(s):</i> Ludwig Mies van der Rohe, 1927</p> <p><i>Award(s):</i> The Museum of Modern Art, New York, USA, 1977; Design Center Stuttgart Award, W.Germany, 1978</p> 	<p>256AS MR side chair with arms</p> 	18"	27"	21"	32 1/2"	31"	24 lbs.
	<p>256CS MR side chair, armless</p> 	18"		19 1/4"	27 1/4"	31"	17 lbs.
	256AKIT Replacement sling kit with laces for arm chair						
	256CKIT Replacement sling kit with laces for armless chair						
	256LACE Replacement leather laces for arm/armless chair						

Order Code

<i>Example:</i>	256AS-L82
256AS	MR side chair with arms
L82	Light Brown cowhide

Note:
The MR chairs are part of a collection. Please refer to Mies side chairs and lounge seating beginning on page 182 and tables, beginning on page 346.

Specify:

1. Pattern number
2. Cowhide selection

Ordering Information

Cowhide Selection:
Black(suffix L80)
Light Brown (suffix L82)
White Beige (suffix L84)

Upholstery/COM information:
Prices shown include leather upholstery.
No Customer's Own Material is available.

Note:
The KnollStudio logo and signature of Ludwig Mies van der Rohe is stamped into the base of the MR chair. Every piece of furniture has an individual production number of identification and authenticity.

The MR Chair is Greenguard certified.

Maintenance:
See pages 28-29.

Construction

MR CHAIR
Frame:
Tubular stainless steel in polished finish.

Upholstery:
Thick cowhide sling with leather laces.

Glides:
Four molded clear plastic glides with twin-pin snap-in construction included with all MR chairs.

Replacement Slings:
Slings can be replaced in the field by field services or a furniture repair specialist. Kit includes back and seat replacement slings with laces. Slings should be fitted by field services or by a professional reupholsterer.

pattern no.

256AS-L()	\$3,601.
------------	----------

256CS-L()	2,296.
------------	--------







256AKIT-L()	1,102.
--------------	--------

256CKIT-L()	1,102.
--------------	--------

256LACE-L()	84.
--------------	-----

Ludwig Mies van der Rohe

Barcelona® Lounge Seating

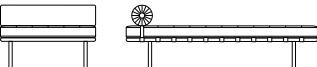
description	frame	straps	seat h	bolster			req. leather sq. ft.	weight			
				h	w	d					
<i>Designer(s):</i> Mies van der Rohe, 1929			250L Barcelona chair		chrome	17"	29 1/2"	30"	30 1/4"	50	47 lbs.
			stainless	17"	29 1/2"	30"	30 1/4"	50	53 lbs.		
<i>Award(s):</i> The Museum of Modern Art, New York, USA, 1977			251Y Barcelona stool		chrome	14 3/4"	25"	23 1/4"	14 3/4"	25	28 lbs.
			stainless	14 3/4"	25"	23 1/4"	14 3/4"	25	31 lbs.		
			251YC-L80 Barcelona stool with cowhide sling		chrome	12 1/4"	21 1/2"	23"	12 1/4"	n/a	26 lbs.
			250LC-S Child's Barcelona chair		chrome	14"	24"	24"	25"	32	41 lbs.
			251YC-S Child's Barcelona stool		chrome	12"	19"	18"	12"	15	25 lbs.
			258L Barcelona couch		stainless	black	15.35"	25"	39"	78"	25"
				stainless	colors	15.35"	25"	39"	78"	25"	84 lbs.

Order Code

<i>Example:</i>	250LS-DV116
250LS	Barcelona chair
DV116	Ducale Velour, Lava

Note:
Barcelona lounge seating and couch are part of a collection. Please refer to Mies side chairs and lounge seating beginning on page 182 and tables, beginning on page 346.

Specify:

1. Pattern number
2. Cal 133 Fire Code option (chair and stool only)
3. Leather selection

Ordering Information

Upholstery note:
Prices shown include leather upholstery and strap selection. **No Customer's Own Material can be used.**

 **KnollStudio 20-day Program:**
The Barcelona chair and stool are available on the KnollStudio 20-day program with black volo leather and a chrome base. For specific information, consult pages 30-33.

Cal 133 Fire Code :

The Barcelona Lounge Chair and Stool comply with the California Technical Bulletin 133 standard if upholstered in Cal 133 approved upholstery. Specify suffix -C after pattern number. Upcharge applies, see page 19.

Maintenance:

See pages 28-29.

Note:

The KnollStudio logo and signature of Ludwig Mies van der Rohe is stamped on each piece.

The Barcelona Lounge Seating Collection is Greenguard certified.

The Child's Barcelona chair and stool are compliant to the Consumer Product Safety Improvement Act of 2008 for Children's Products, 16 C.F.R. 1303, CPSIA Title 1 Section 101 for Total Lead in Substrates and Surface Coatings.

Construction

BARCELONA CHAIR AND STOOL



Stainless Steel Frame:
Premium grade 304 bar stock stainless steel. Single piece construction ensures long-term durability. Frame is shaped, welded and hand-buffed to mirror finish. Upholstery straps attached with solid stainless steel screws.

Chrome Frame:

Hand-ground and hand-buffed to a mirror finish. Upholstery attaches with aluminum rivets.

Upholstery straps:

Cowhide belting straps. Side and all sides are dyed to match specified upholstery color. Chair contains 17 belting support straps; stool 7. Child's Chair contains 13 belting support straps; stool 7.

pattern no.	cowhide	U	V	W	X	Y
250LC 		\$8,224.	\$10,125.	\$10,775.	\$10,906.	\$11,063.
250LS		12,559.	12,991.	13,768.	13,904.	14,116.
<hr/>						
251YC 		3,888.	4,778.	5,103.	5,169.	5,247.
251YS		7,268.	7,459.	7,847.	7,941.	8,024.
<hr/>						
251YC-L80	2,665.					
<hr/>						
250LC-S		6,980.	8,597.	9,147.	9,260.	9,395.
<hr/>						
251YC-S		3,300.	4,057.	4,331.	4,390.	4,456.
<hr/>						
258LS-(HO1)		14,370.	14,923.	16,047.	16,280.	16,552.
258LS-()		15,482.	16,285.	17,922.	18,260.	18,655.

Upholstery:
Chair has 40 individual panels for the chair and 16 for the stool; Child's Chair has 40 individual panels for the chair and 16 for the stool. Individual panels are cut, hand-welted, and hand-tufted with leather and buttons produced from a single cowhide. Cushions are premium quality, highly resilient urethane foam with down-like dacron polyester fiberfill.

Child's Barcelona Chair and Stool:
The Child's Barcelona Chair and Stool is 80% scale of standard size.

BARCELONA STOOL WITH COWHIDE SLING:
Thick cowhide sling in black with nylon laces on a chrome frame.

BARCELONA COUCH
Platform:
Hardwood frame is Sapele Mahogany from Africa. Wood has oak-like strength and is characterized by a dark or reddish-brown color. Frame is finished with a protective clear lacquer finish. 11 thick cowhide leather straps over rubber webbing.

Legs:
Tubular steel in polished stainless steel finish.

Bolster:
Bolster in matching leather is secured to cushion platform with straps complete with lock snaps.

Upholstery straps:
Cowhide belting straps with front, back, and side edges all stained to match specified upholstery color. For black straps, specify option (HO1). For matching straps in all other colors, specify leather upholstery selection and straps will be produced to match. Couch contains 11 belting support straps over rubber webbing.

Upholstery:
72 individual panels are cut, hand-welted and hand-tufted with leather and buttons produced from a single cowhide. Cushions are premium quality, fire retardant, high resilient urethane foam with down-like dacron polyester fiberfill.

Spinneybeck Leather

- | | |
|--|---|
| U
Vicenza 
Volo  | X
Ducale 
Ducale Velours  |
| V
Acqua 
Andes 
Embossed Tipped *
España 
Hand Tipped  *
Maremma 
Velluto Pelle  | Y
Capri 
Cervo  *
Copenhagen 
Cordovan 
Distressed 
Lucca
Marissa 
Portofino  *
Prima 
Riva 
Saddle 
Salon  |
| W
Alaska 
Amazon 
Antique 
Arizona 
Derby 
Forte 
Lucente  *
Sabrina  | |

 Approved for Cal 133 upholstery.
* Not approved for Cal133 upholstery on 258LS.

Check with your KnollTextiles or Spinneybeck Representative for changes or additions.

Ludwig Mies van der Rohe

Krefeld™ Collection

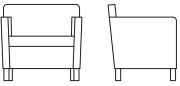
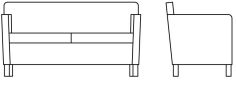
description	seat h	arm h	w	d	h	type	textile	req.	weight
							fabric	leather	
	yds.	sq. ft.							
751 Lounge chair 	17 1/4"	25"	32"	27"	30"		6.5	80	59 lbs.
Lounge chair in textile with leather welt option						uphol.	6.5		
						welt		21	
752 Settee 	17 1/4"	25"	57"	27"	30"		8	120	93 lbs.
Settee in textile with leather welt option						uphol.	8		
						welt		25	

Designer(s):
Ludwig Mies van der Rohe, 1930
Design from the Mies van der Rohe Archive of The Museum of Modern Art



Order Code

<i>Example:</i>	751-AWE-DV112
751	Krefeld lounge chair
AWE	Wenge legs
DV112	Ducale Velour, Brandy
<i>Example:</i>	752-AWA-K1026/3-VO904
752	Krefeld settee
AWA	Light Walnut legs
K1026/3	Cross Stitch, Windsor
VO904	Volo, Stallion welt

Krefeld lounge seating is part of a collection. Please refer to Mies side chairs and lounge seating beginning on page 182 and tables, beginning on page 346.

Specify:

1. Pattern number
2. Leg finish
3. Textile selection

Leather Welt selection, specify:

1. Pattern number
2. Leg finish
3. Textile selection
4. Leather Welt Selection (upcharge applies)

Ordering Information

Leg finishes:

Clear Oak (suffix AOC)
Deep Red Mahogany (suffix AF)
Light Walnut (suffix AWA)
Medium Cherry (suffix AM)
Wenge (suffix AWE)

Leather Welt Option:

The Krefeld collection may be specified with an optional leather welt option. Welt contours all edges, including cushions. Please specify pattern number with LT suffix and add appropriate leather upcharge for total list price of the piece. Leather welt option is available on textile upholstery only.

Cal 133 Fire Code#:

The Krefeld Lounge Collection complies with the California Technical Bulletin 133 standard if upholstered in Cal 133 approved upholstery. Specify suffix -C after pattern number. Upcharge applies, see page 19.

Maintenance:

See pages 28-29.

Note:

The Krefeld Collection is Greenguard certified.

Construction

Frame:

Inner frame in engineered hardwood and plywood. Legs are removable, and are attached to metal plate attached to frame. Coil spring suspension for enhanced comfort. Dynamic suspension in the back for added flexibility and support. Legs are ash hardwood stained (in wenge, medium cherry, deep red mahogany, walnut and clear oak).

Upholstery:

High-density foam cushions with dacron top layer. Benches and ottoman feature dual density foam for added softness and support. Side panel upholstery is tailored to fit, seat and back cushions are more loose.

Inside dimensions:

751 Lounge Chair:
d: 21"
w: 26" *

752 Settee:

d: 21"
w: 51" *

753 Sofa:

d: 21"
w: 76" *

*Width measured at the inside of the front of the arms. The chair tapers back, resulting in less width at the back of the chair than the front.

pattern no.	grades													
	A	B	C	D	E	F	G	H	I	U	V	W	X	Y
751-(-)-(-)	\$3,464.	\$3,744.	\$4,006.	\$4,298.	\$4,534.	\$4,709.	\$4,998.	\$5,556.	\$6,123.	\$6,888.	\$7,394.	\$8,438.	\$8,651.	\$8,904.
751LT-(-)-(-)	3,464.	3,744.	4,006.	4,298.	4,534.	4,709.	4,998.	5,556.	6,123.					
upchg, welt										973.	1,095.	1,342.	1,394.	1,453.
752-(-)-(-)	5,454.	5,741.	6,019.	6,323.	6,570.	6,753.	7,058.	7,640.	8,067.	10,794.	11,466.	12,830.	13,114.	13,444.
752LT-(-)-(-)	5,454.	5,741.	6,019.	6,323.	6,570.	6,753.	7,058.	7,640.	8,067.					
upchg, welt										1,151.	1,295.	1,590.	1,652.	1,721.

Approved KnollTextiles Grades/Fabrics

A	Alignment ‡ Beacon Bocce Cat's Cradle Chance Common Ground ‡ Commuter Cloth ‡ Delite Hourglass Mariner Metaphor Monarch ‡ Prep ‡ Sonnet Stacks Trophy	B continued Digit Ferry Gala II Grande Grandview Holbrook Journey Keaton Knoll Felt ‡ Knoll Hopsack ‡ Ludlow Lyric ‡ Night Life Nonchalant CR Paradigm Petal Pusher Prairie Prim ‡ Pogo Pop Radiance Ransom Ricochet ‡ Roam Rush Hour Soiree Spark ‡ Spree Starry Night ‡ Summit Sutton ‡ Synth Tabloid Venue Versa Vinyl Westwood Wide Angle ‡ Zephyr Zipline	C Atlas Autobahn Axiom Biota ‡ Cairo Charm Circa Classic Boucle Dahlia CR Decade Durand Earthwork ‡ Echo Empire Stripe Entourage Fable CR Fibra Greenwich Hudson Hula Hoop Kora CR Lagos Lore CR Metro Milestone Moto CR Palisade Panache CR Quark Roundtrip	C continued Sahara Sequin CR Spot On Star Struck Stepping Stones Swing Tight Rope Tilden Tower Grid Transition ‡ Vibe Zari CR	D Coterie Eclat Weave Hologram Island Masquerade Menagerie Origins Satellite Satin Chisel Theory Woodland Zoom
E	Highland Ikat Square Ikat Stripe Kampala Katazome Kimono Luberon Mamba Marquee Meroe Sherman Shima Tryst Whip	F Atelier Biscayne Calais Cotton Velvet Century Coco Cornaro Eclipse Glider Icon Intrigue Liberty Mod Plaid Rivington Soon Topography Totem			
G	Djenne Hampshire Haze Kinabalu Kingston Melange Spencer Ultrasuede ‡	H Arno Constance Firefly Gezelle Magritte Rosemond	I Byron Cato Diamond Days Dynamic Gates Knoll Velvet Olema Piper Ravello Rutledge Sandis Tudor Vermeer Walker Worth Zimba		

Spinneybeck Leather

U Vicenza ‡ Volo ‡	V Acqua ‡ Andes ‡ Embossed Tipped España ‡ Hand Tipped ‡ Velluto Pelle ‡	W Alaska ‡ Amazon ‡ Antique ‡ Arizona ‡ Forte ‡ Lucente Sabrina ‡	Y Capri ‡ Cervo Copenhagen ‡ Cordovan ‡ Distressed ‡ Marissa ‡ Prima ‡ Riva ‡ Saddle ‡
---------------------------------	---	---	--

‡ Approved for Cal 133 upholstery.

Check with your KnollTextiles or Spinneybeck Representative for changes or additions.

Ludwig Mies van der Rohe

Krefeld™ Collection

description	seat h	arm h	w	d	h	type	textile	req.	weight	
							fabric	leather		
yds.	sq. ft.									
753 Sofa	17 1/4"	25"	82"	27"	30"		11	160	122 lbs.	
Sofa in textile with leather welt option							uphol.	11		
							welt		34	
754 Ottoman	17 1/4"		26"	20 1/2"	17 1/4"		3	50	17 lbs.	
Ottoman in textile with leather welt option							uphol.	3		
							welt		15	

Designer(s):
Ludwig Mies van der Rohe, 1930
Design from the Mies van der Rohe Archive of The Museum of Modern Art

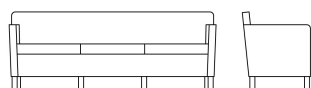

Order Code

<i>Example:</i>	751-AWE-DV112
751	Krefeld lounge chair
AWE	Wenge legs
DV112	Ducale Velour, Brandy
<i>Example:</i>	752-AWA-K1026/3-VO904
752	Krefeld settee
AWA	Light Walnut legs
K1026/3	Cross Stitch, Windsor
VO904	Volo, Stallion welt

Krefeld lounge seating is part of a collection. Please refer to Mies side chairs and lounge seating beginning on page 132 and tables, beginning on page 346.

Specify:

1. Pattern number
2. Leg finish
3. Textile selection

Leather Welt selection, specify:

1. Pattern number
2. Leg finish
3. Textile selection
4. Leather Welt Selection (upcharge applies)

Ordering Information

Leg finishes:

Clear Oak (suffix AOC)
Deep Red Mahogany (suffix AF)
Light Walnut (suffix AWA)
Medium Cherry (suffix AM)
Wenge (suffix AWE)

Leather Welt Option:

The Krefeld collection may be specified with an optional leather welt option. Welt contours all edges, including cushions. Please specify pattern number with LT suffix and add appropriate leather upcharge for total list price of the piece. Leather welt option is available on textile upholstery only.

Cal 133 Fire Code#:

The Krefeld Lounge Collection complies with the California Technical Bulletin 133 standard if upholstered in Cal 133 approved upholstery. Specify suffix -C after pattern number. Upcharge applies, see page 19.

Maintenance:

See pages 28-29.

Note:

The Krefeld Collection is Greenguard certified.

Construction

Frame:

Inner frame in engineered hardwood and plywood. Legs are removable, and are attached to metal plate attached to frame. Coil spring suspension for enhanced comfort. Dynamic suspension in the back for added flexibility and support. Legs are ash hardwood stained (in wenge, medium cherry, deep red mahogany, walnut and clear oak).

Upholstery:

High-density foam cushions with dacron top layer. Benches and ottoman feature dual density foam for added softness and support. Side panel upholstery is tailored to fit, seat and back cushions are more loose.

Inside dimensions:

751 Lounge Chair:
d: 21"
w: 26" *

752 Settee:

d: 21"
w: 51" *

753 Sofa:

d: 21"
w: 76" *

*Width measured at the inside of the front of the arms. The chair tapers back, resulting in less width at the back of the chair than the front.

pattern no.	grades									COL				
	A	B	C	D	E	F	G	H	I	U	V	W	X	Y
753-(-)(-)	\$7,104.	\$7,436.	\$7,752.	\$8,103.	\$8,391.	\$8,597.	\$8,947.	\$9,614.	\$10,105.	\$13,734.	\$14,548.	\$16,212.	\$16,557.	\$16,960.
753LT-(-)(-)(-)	7,104.	7,436.	7,752.	8,103.	8,391.	8,597.	8,947.	9,614.	10,105.					
upchg, welt										1,564.	1,762.	2,161.	2,244.	2,341.
754-(-)(-)	2,031.	2,116.	2,197.	2,286.	2,360.	2,412.	2,502.	2,672.	2,797.	3,741.	3,932.	4,325.	4,408.	4,502.
754LT-(-)(-)(-)	2,031.	2,116.	2,197.	2,286.	2,360.	2,412.	2,502.	2,672.	2,797.					
upchg, welt										690.	778.	954.	991.	1,033.

Approved KnollTextiles Grades/Fabrics

A	B continued	C	C continued
Alignment ‡	Digit	Atlas	Sahara
Beacon	Ferry	Autobahn	Sequin CR
Bocce	Gala II	Axiom	Spot On
Cat's Cradle	Grande	Biota ‡	Star Struck
Chance	Grandview	Cairo	Stepping Stones
Common Ground ‡	Holbrook	Charm	Swing
Commuter Cloth ‡	Journey	Circa	Tight Rope
Delite	Keaton	Classic Boucle	Tilden
Hourglass	Knoll Felt ‡	Dahlia CR	Tower Grid
Mariner	Knoll Hopsack ‡	Decade	Transition ‡
Metaphor	Ludlow	Durand	Vibe
Monarch ‡	Lyric ‡	Earthwork ‡	Zari CR
Prep ‡	Night Life	Echo	
Sonnet	Nonchalant CR	Empire Stripe	D
Stacks	Paradigm	Entourage	Coterie
Trophy	Petal Pusher	Fable CR	Eclat Weave
	Prairie	Fibra	Hologram
	Prim ‡	Greenwich	Island
B	Pogo	Hudson	Masquerade
Abacus ‡	Pop	Hula Hoop	Menagerie
Argyle	Radiance	Kora CR	Origins
Bank Shot	Ransom	Lagos	Satellite
Belize	Ricochet ‡	Lore CR	Satin Chisel
Bistro ‡	Roam	Metro	Theory
Cameo	Rush Hour	Milestone	Woodland
Chroma ‡	Soiree	Moto CR	Zoom
Chronicle	Spark ‡	Palisade	
	Spree	Panache CR	
	Starry Night ‡	Quark	
	Summit	Roundtrip	
	Sutton ‡		
	Synth		
	Tabloid		
	Venue		
	Versa		
	Vinyl		
	Westwood		
	Wide Angle ‡		
	Zephyr		
	Zipline		

Spinneybeck Leather

U	V	W	Y
Vicenza ‡	Acqua ‡	Alaska ‡	Capri ‡
Volo ‡	Andes ‡	Amazon ‡	Cervo
	Embossed Tipped	Antique ‡	Copenhagen ‡
	España ‡	Arizona ‡	Cordovan ‡
	Hand Tipped ‡	Forte ‡	Distressed ‡
	Velluto Pelle ‡	Lucente	Marissa ‡
		Sabrina ‡	Prima ‡
			Riva ‡
			Saddle ‡

‡ Approved for Cal 133 upholstery.

Check with your KnollTextiles or Spinneybeck Representative for changes or additions.

Ludwig Mies van der Rohe

Krefeld™ Collection

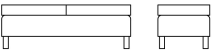
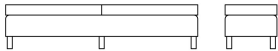
description	seat h	arm h	w	d	h	type	textile	req.	weight	
							fabric	leather		
yds.	sq. ft.									
755 Medium Bench	17 1/4"		51"	20 1/2"	17 1/4"		5	64	21 lbs.	
										
Medium Bench in textile with leather welt option							uphol.	5		
							welt	20		
756 Large Bench	17 1/4"		76"	20 1/2"	17 1/4"		5.5	80	45 lbs.	
										
Large Bench in textile with leather welt option							uphol.	5.5		
							welt	20		

Designer(s):
Ludwig Mies van der Rohe, 1930
Design from the Mies van der Rohe Archive of The Museum of Modern Art



Order Code

<i>Example:</i>	751-AWE-DV112
751	Krefeld lounge chair
AWE	Wenge legs
DV112	Ducale Velour, Brandy
<i>Example:</i>	752-AWA-K1026/3-VO904
752	Krefeld settee
AWA	Light Walnut legs
K1026/3	Cross Stitch, Windsor
VO904	Volo, Stallion welt

Krefeld lounge seating is part of a collection. Please refer to Mies side chairs and lounge seating beginning on page 132 and tables, beginning on page 346.

Specify:

1. Pattern number
2. Leg finish
3. Textile selection

Leather Welt selection, specify:

1. Pattern number
2. Leg finish
3. Textile selection
4. Leather Welt Selection (upcharge applies)

Ordering Information

Leg finishes:

Clear Oak (suffix AOC)
Deep Red Mahogany (suffix AF)
Light Walnut (suffix AWA)
Medium Cherry (suffix AM)
Wenge (suffix AWE)

Leather Welt Option:

The Krefeld collection may be specified with an optional leather welt option. Welt contours all edges, including cushions. Please specify pattern number with LT suffix and add appropriate leather upcharge for total list price of the piece. Leather welt option is available on textile upholstery only.

Cal 133 Fire Code#:

The Krefeld Lounge Collection complies with the California Technical Bulletin 133 standard if upholstered in Cal 133 approved upholstery. Specify suffix -C after pattern number. Upcharge applies, see page 19.

Maintenance:

See pages 28-29.

Note:

The Krefeld Collection is Greenguard certified.

Construction

Frame:

Inner frame in engineered hardwood and plywood. Legs are removable, and are attached to metal plate attached to frame. Coil spring suspension for enhanced comfort. Dynamic suspension in the back for added flexibility and support. Legs are ash hardwood stained (in wenge, medium cherry, deep red mahogany, walnut and clear oak).

Upholstery:

High-density foam cushions with dacron top layer. Benches and ottoman feature dual density foam for added softness and support. Side panel upholstery is tailored to fit, seat and back cushions are more loose.

Inside dimensions:

751 Lounge Chair:
d: 21"
w: 26" *

752 Settee:
d: 21"
w: 51" *

753 Sofa:
d: 21"
w: 76" *

*Width measured at the inside of the front of the arms. The chair tapers back, resulting in less width at the back of the chair than the front.

pattern no.	grades A	COM B	C	D	E	F	G	H	I	COL U	V	W	X	Y
755-(-)(-)	\$2,817.	\$2,964.	\$3,109.	\$3,267.	\$3,395.	\$3,489.	\$3,645.	\$3,947.	\$4,167.	\$4,471.	\$4,849.	\$5,620.	\$5,780.	\$5,965.
755LT-(-)(-)(-)	2,817.	2,964.	3,109.	3,267.	3,395.	3,489.	3,645.	3,947.	4,167.					
upchg, welt										922.	1,040.	1,284.	1,336.	1,395.
756-(-)(-)	3,269.	3,468.	3,662.	3,870.	4,044.	4,167.	4,376.	4,778.	5,074.	5,827.	6,360.	7,440.	7,663.	7,926.
756LT-(-)(-)(-)	3,269.	3,468.	3,662.	3,870.	4,044.	4,167.	4,376.	4,778.	5,074.					
upchg, welt										951.	1,069.	1,313.	1,365.	1,424.

Approved KnollTextiles Grades/Fabrics

A	Alignment ‡ Beacon Bocce Cat's Cradle Chance Common Ground ‡ Commuter Cloth ‡ Delite Hourglass Mariner Metaphor Monarch ‡ Prep ‡ Sonnet Stacks Trophy	B continued Digit Ferry Gala II Grande Grandview Holbrook Journey Keaton Knoll Felt ‡ Knoll Hopsack ‡ Ludlow Lyric ‡ Night Life Nonchalant CR Paradigm Petal Pusher Prairie Prim ‡ Pogo Pop Radiance Ransom Ricochet ‡ Roam Rush Hour Soiree Spark ‡ Spree Starry Night ‡ Summit Sutton ‡ Synth Tabloid Venue Versa Vinyl Westwood Wide Angle ‡ Zephyr Zipline	C Atlas Autobahn Axiom Biota ‡ Cairo Charm Circa Classic Boucle Dahlia CR Decade Durand Earthwork ‡ Echo Empire Stripe Entourage Fable CR Fibra Greenwich Hudson Hula Hoop Kora CR Lagos Lore CR Metro Milestone Moto CR Palisade Panache CR Quark Roundtrip	C continued Sahara Sequin CR Spot On Star Struck Stepping Stones Swing Tight Rope Tilden Tower Grid Transition ‡ Vibe Zari CR	D Coterie Eclat Weave Hologram Island Masquerade Menagerie Origins Satellite Satin Chisel Theory Woodland Zoom
----------	--	---	---	--	---



Spinneybeck Leather

E Highland Ikat Square Ikat Stripe Kampala Katazome Kimono Luberon Mamba Marquee Meroe Sherman Shima Tryst Whip	F Atelier Biscayne Calais Cotton Velvet Century Coco Cornaro Eclipse Glider Icon Intrigue Liberty Mod Plaid Rivington Soon Topography Totem	G Djenne Hampshire Haze Kinabalu Kingston Melange Spencer Ultrasuede ‡	H Arno Constance Firefly Gezelle Magritte Rosemond	I Byron Cato Diamond Days Dynamic Gates Knoll Velvet Olema Piper Ravello Rutledge Sandis Tudor Vermeer Walker Worth Zimba	U Vicenza ‡ Volo ‡	V Acqua ‡ Andes ‡ Embossed Tipped España ‡ Hand Tipped ‡ Velluto Pelle ‡	W Alaska ‡ Amazon ‡ Antique ‡ Arizona ‡ Forte ‡ Lucente Sabrina ‡	Y Capri ‡ Cervo Copenhagen ‡ Cordovan ‡ Distressed ‡ Marissa ‡ Prima ‡ Riva ‡ Saddle ‡
--	---	---	---	--	---------------------------------	---	---	--

‡ Approved for Cal 133 upholstery.

Check with your KnollTextiles or Spinneybeck Representative for changes or additions.

George Nakashima Straight Chair

	description	seat h	w	d	h	weight
<p><i>Designer(s):</i> George Nakashima, 1946</p> 	<p>N19 Straight Chair</p> 	17 1/4"	22 1/2"	17 1/2"	30"	11 lbs.

Order Code

<i>Example:</i>	N19-AW
N19	Straight Chair
AW	American Walnut

Note:
The Straight chair is part of a collection. Please refer to the Splay-Leg table on page 356.

Specify:
1. Pattern number
2. Finish

Ordering Information

Finishes:
American Walnut (suffix AW)

Maintenance:
See pages 28-29.

Note:
The Straight Chair is Greenguard certified.

Each chair features George Nakashima's signature under the seat.

Construction

Frame:
Constructed from solid American Walnut, turned American Walnut legs and stretchers, and contrasting Hickory spindles, clear low-sheen finish and nylon glides.

Note:
American Walnut exhibits a high degree of natural color characteristics, ranging from chocolate, grey and purplish-browns to deep honey. Color variation will soften and become more uniform over time.



pattern no.

N19-AW

\$1,153.

Jonathan Olivares

Aluminum Stacking Chair

	description	seat h	w	d	h	weight
<p><i>Designer(s):</i> Jonathan Olivares, 2012</p> 	<p>OAC1 Olivares Chair</p> 	17 1/2"	22 1/3"	21 1/2"	31 1/5"	15 lbs.

Order Code

Example: **OAC1-WHT**

OAC1 Olivares chair

WHT White paint finish

Specify:

1. Pattern number
2. Paint finish selection

Ordering Information

Paint finishes:

White (suffix WHT)
 Grey (suffix GRY)
 Yellow (suffix YEL)
 Lime Green (suffix LGR)
 Orange (suffix ORG)
 Plum (suffix PLM)
 Sky Blue (suffix SBL)
 Blue (suffix BLU)
 Dark Charcoal (CHR)

Maintenance:

See pages 28-29.

Construction

Shell:

Constructed from die-cast aluminum with integrated leg tenons. A long low-profile nylon stacking bumper distributes the chair's weight over a wide area providing a more stable stacking condition. The designer's signature and KnollStudio logo are located under the seat.

Legs:

Aluminum extruded legs are secured to the chair's shell using epoxy and stainless steel fasteners.

Paint:

Ultra-durable polyester powder coat paint.

Glides:

1/4" flat nylon glides.

Stacking:

Chairs stack six on the floor.

Outdoor use:

With proper preventative maintenance, the Olivares chair is appropriate for outdoor environments.

pattern no.



list

OAC1-()

\$896.

Jorge Pensi

Toledo Stacking Chair

	description	seat h	arm h	w	d	h	textile fabric yds.	req. leather sq. ft.	weight
<p><i>Designer(s):</i> Jorge Pensi, 1988</p> <p><i>Award(s):</i> First Place, Sidi Selection, Valencia, Spain, 1988; "Delta Plate" of ADI FAD, 1988; Design Center Stuttgart Award, W. Germany, 1990</p>	<p>29C Toledo Chair</p> 	17 7/8"	27 1/4"	21 3/8"	21 1/4"	29 7/8"			15 lbs.
	<p>29K Toledo Chair, seat cushion replacement</p> 						0.6	7	



Order Code

<i>Example:</i>	29C-29K-K161/1
29C	Toledo chair
29K	Seat cushion option
K161/1	Classic Boucle, Pearl

Note:
Toledo Chairs are part of a collection. Please refer to Pensi Tables on pages 360.

Specify:

1. Pattern number
2. Seat pad option
3. Textile selection

Ordering Information

Note:
The Toledo Chair is available in the United States only.

 *KnollStudio 20-Day Program:*
The Toledo Chair is available on the KnollStudio 20-Day program. For specific information, consult pages 30 - 33.

Upholstery/COM information:
Prices shown include fabric or leather upholstery. Contact your Knoll representative for colors. Only approved KnollTextiles and Spinneybeck leathers may be ordered.

Customer's Own Material is available pending approval. For approval requirements, processing instructions and ordering information please see page 18.

Cal 133 Fire Code #:
The Toledo Chair without seat pad complies with California Technical Bulletin 133. See page 18.

Maintenance:
See pages 28-29.

Note:
Toledo Chairs are stamped under the seat with the name of the designer and the manufacturer, AMAT 3.

The Toledo Stacking Chair is Greenguard certified.

Construction

Seat, back, arms:
Polished cast aluminum, thermo-treated.

Legs:
Anodized, polished tubular aluminum. The Toledo chair is 100% recyclable.

Stacking feature:
Chairs can be stacked up to 4 high for compact storage.

Outdoor use:
With proper preventative maintenance, the Toledo Chair is appropriate for outdoor environments. Aluminum will not reflect extreme outdoor temperatures.

Optional seat pad:
Regardless of the textile, the seat pad is not approved for outdoor use.

pattern no.	grades	COM	A	B	C	D	E	F	G	H	I	COL	U	V	W	X	Y
29C																	
	\$1,879.																

29K	266.	290.	309.	334.	352.	366.	390.	437.	472.	466.	520.	624.	646.	672.
-----	------	------	------	------	------	------	------	------	------	------	------	------	------	------

Approved KnollTextiles Grades/Fabrics

A Alignment Analogy Beacon Bocce Cat's Cradle Chance Common Ground Commuter Cloth Delite Dristi Foil Rap Heavy Metal Hourglass Mariner Metaphor Monarch Prep Presto Soliloquy Sonnet Stacks Trophy	B Abacus Argyle Backdrop Bank Shot Belize Betwixt Bistro Boundary Cameo Chroma Chronicle Close Knit Digit Digital Tape Dovetail Fast Forward Ferry	E continued Forza Gala II Grande Grandview Holbrook Journey Keaton Knoll Felt Knoll Hopsack Ludlow Lyric Mini Stitch Night Life Nonchalant CR Paradigm Petal Pusher Pogo Pop Prairie Prim Radiance Ransom Ricochet Roam Rush Hour Soiree Spark Spinoff Nuance Spree Starry Night Sutton Synth Tabloid Venue Versa Vinyl Westwood Wide Angle Zephyr Zipline	C Atlas Autobahn Axiom Baxter Biota Charm Circa Classic Boucle Dahlia CR Decade Durand Earthwork Echo Empire Stripe Enmesh Entourage Fable CR Fibra Greenwich Hudson Hula Hoop Kaleidoscope CR Kora CR Legend CR Lagos Lore CR Magnolia Metro Milestone Moto CR Noble Palisade Panache CR Posh Quark Regard CR Roundtrip Sequin CR Sahara Sandpiper Sinclair Smart Spectator	C continued Spot On Star Struck Stepping Stones Swing Tight Rope Tilden Tower Grid Transition Treble CR Vibe Zari CR	D Compass CR Coterie Eclat Weave Hologram In The Loop Masquerade Menagerie Origins Satellite Satin Chisel Tara Theory Zoom	E Highland Ikat Square Ikat Stripe Katazome Kampala Kimono Luberon Mamba Marquee Meroe Sherman Shima Tryst Whip
---	--	---	--	--	--	--

Spinneybeck Leather

U Vicenza Volo	V Acqua Andes Embossed Tipped España Hand Tipped Maremma Velluto Pelle	W Alaska Amazon Antique Arizona Derby Forte Lucente Sabrina	X Ducale Ducale Velour
Y Capri Cervo Copenhagen Cordovan Distressed Lucca Marissa Portofino Prima Riva Torello			

Check with your KnollTextiles or Spinneybeck Representative for changes or additions.

Charles Pfister

Petite Lounge Seating

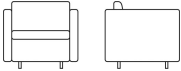
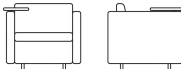
	description	seat h	arm h	w	d	h	textile fabric yds.	req. leather sq. ft.	weight
Designer(s): Charles Pfister, 1971 	1051C-S Petite lounge chair 	16"	24"	29½"	29½"	26"	6.5	117	39 lbs.
	1051C-ST-() Petite Pfister lounge chair with optional tablet arm 	16"	24"	29½"	29½"	26"	6.5	117	41 lbs.

Order Code

<i>Example:</i>	1051C-ST-R-H-K109/15
1051C	Petite Pfister lounge chair
ST	Tablet arm option
R	Right handed tablet arm
H	Caster option
K109/15	Haze, Persimmon

Specify:

1. Pattern number
2. Cal 133 Fire Code option
3. Tablet option (lounge chair only), right or left
4. Caster option (lounge chair only)
5. Textile selection

Ordering Information

Tablet arm option (suffix ST),

lounge chair only:

Left handed (suffix L)

Right handed (suffix R)

Caster option (suffix H),

lounge chair only:

To specify four casters add -H to end of pattern number before upholstery selection.

Upholstery/COM information:

Prices shown include fabric or leather upholstery. Contact your Knoll representative for colors. Only approved KnollTextiles and Spinneybeck leathers may be ordered.

Customer's Own Material is available pending approval. Non-railroad COM fabrics will require additional yardage. For approval requirements, processing instructions and ordering information please see page 18.

Cal 133 Fire Code#:

Petite Pfister lounge seating complies with the California Technical Bulletin 133 standard if upholstered in Cal 133 approved upholstery. Specify suffix -C at end of pattern number and suffix -133 at end of textile selection. Upcharge applies, see page 19.

Note:

The Petite Pfister Lounge Seating Collection is Greenguard certified.

Construction

Frame:

Constructed in sections with a combination plywood/hardwood seat and back.

Upholstery:

Petite Pfister lounge seat and back cushion are fully upholstered. Double-needled top stitching on leather upholstery and on thin solid textiles. Single-needled top stitching on heavily ribbed fabrics and multicolor prints. No sag spring deck covered in black cotton textile.

Swivel tablet:

Machined aluminum, post and socket mechanism with black phenolic rectangular tablet; swivels 360°. Tablet dimensions are 10" x 14".

Seat height:

Seat height is measured from the floor to the crown of the seat cushion. Height could vary up to ½" depending on leather or textile specified.

Glides:

Nylon, adjustable.

Cushion fill:

Polyester wrap: foam core with polyester fiber wrap for tight, tailored aesthetic.

pattern no.	upcharge	grades													
		A	B	C	D	E	F	G	H	I	U	V	W	X	Y
1051C-S		\$2,665.	\$2,916.	\$3,155.	\$3,417.	\$3,632.	\$3,784.	\$4,045.	\$4,547.	\$5,058.	\$6,365.	\$7,262.	\$9,166.	\$9,463.	\$9,902.
1051C-ST-()		3,366.	3,615.	3,857.	4,116.	4,331.	4,486.	4,745.	5,248.	5,760.	7,067.	7,962.	9,867.	10,162.	10,604.

Approved KnollTextiles Grades/Fabrics

A	B continued	C	C continued
Alignment ‡	Digit	Atlas	Sequin CR
Beacon	Dovetail	Autobahn	Sinclair
Bocce	Ferry	Axiom	Smart
Cat's Cradle	Gala II	Baxter	Spectator
Chance	Grande	Biota ‡	Spot On
Common Ground ‡	Grandview	Cairo	Star Struck
Commuter Cloth ‡	Holbrook	Charm	Stepping Stones
Cotton Duck	Journey	Circa	Swing
Delite	Keaton	Classic Boucle	Tight Rope
Dristi	Knoll Felt ‡	Dahlia CR	Tilden
Hourglass	Knoll Hopsack ‡	Decade	Tower Grid
Mariner	Ludlow	Dune	Transition
Monarch	Lytic	Durand	Treble CR
Prep	Mini Stitch	Earthwork ‡	Zari CR
Soliloquy	Night Life	Echo	D
Sonnet	Nonchalant CR	Empire Stripe	Compass CR
Stacks	Paradigm	Entourage	Coterie
Trophy	Petal Pusher	Fable CR	Eclat Weave
	Pogo ‡	Fibra	Hologram
B	Pop	Greenwich	Island
Abacus ‡	Prairie	Hudson	Island
Argyle	Prim ‡	Hula Hoop	Masquerade
Bank Shot	Radiance	Kaleidoscope CR	Menagerie
Belize	Ransom	Kora CR	Origins
Betwixt	Ricochet ‡	Lagos	Satellite
Bistro ‡	Roam	Legend CR	Satin Chisel
Boundary ‡	Rush Hour	Lore CR	Tara
Cameo	Soiree	Magnolia	Theory
Chroma ‡	Spark ‡	Metro	Woodland
Chronicle	Spinoff Nuance ‡	Milestone	Zoom
	Spree	Moto CR	E
	Starry Night ‡	Noble	Highland
	Summit	Palisade	Ikat Square
	Sutton	Panache CR	Ikat Stripe
	Synth	Posh	Kampala
	Tabloid	Quark	Katazome
	Venue	Regard CR	Kimono
	Versa	Roundtrip	Luberon
	Vinyl	Sahara	Mamba
	Westwood	Sandpiper	Marquee
	Wide Angle ‡		Meroe
	Zephyr		Sherman
	Zipline		Shima
			Tryst
			Whip

Spinneybeck Leather

U	X
Vicenza ‡	Ducale ‡
Volo ‡	Ducale Velour ‡
V	Y
Acqua ‡	Capri ‡
Andes ‡	Cervo
Embossed Tipped	Copenhagen ‡
España ‡	Cordovan ‡
Hand Tipped	Distressed ‡
Maremma	Lucca
Velluto Pelle ‡	Marissa ‡
W	Portofino
Alaska ‡	Prima ‡
Amazon ‡	Riva ‡
Antique ‡	Saddle ‡
Arizona ‡	Salon ‡
Derby ‡	Torello
Forte ‡	
Lucente ‡	
Sabrina ‡	

‡ Approved for Cal 133 upholstery.



Check with your KnollTextiles or Spinneybeck Representative for changes or additions.

Charles Pfister

Petite Lounge Seating

Designer(s):
Charles Pfister, 1971

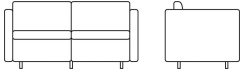
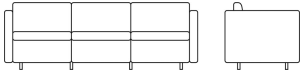

description	height, seat	height, arm	width	depth	height	textile fabric yards	leather sq ft	weight
1052C-S Petite settee 	16"	24"	53"	29 1/2"	26"	10.8	194	64 lbs.
1053C-S Petite sofa 	16"	24"	76 1/2"	29 1/2"	26"	15.0	270	88 lbs.
1059C-S Petite ottoman 			22"	22"	16"	3.8	69	18 lbs.
H Optional casters for Petite lounge chair								

Order Code

<i>Example:</i>	1051C-ST-R-H-K109/15
1051C	Petite Pfister lounge chair
ST	Tablet arm option
R	Right handed tablet arm
H	Caster option
K109/15	Haze, Persimmon

Specify:

1. Pattern number
2. Cal 133 Fire Code option
3. Tablet arm (lounge chair only), right or left
4. Caster option (lounge chair only)
5. Textile selection

Ordering Information

Tablet arm option (suffix ST), lounge chair only:
Left handed (suffix L)
Right handed (suffix R)

Caster option (suffix H), lounge chair only:
To specify four casters add -H to end of pattern number before upholstery selection.

Upholstery/COM information:
Prices shown include fabric or leather upholstery. Contact your Knoll representative for colors. Only approved KnollTextiles and Spinneybeck leathers may be ordered.

Customer's Own Material is available pending approval. Non-railroad COM fabrics will require additional yardage. For approval requirements, processing instructions and ordering information please see page 18.

Cal 133 Fire Code#:
Petite Pfister lounge seating complies with the California Technical Bulletin 133 standard if upholstered in Cal 133 approved upholstery. Specify suffix -C at end of pattern number and suffix -133 at end of textile selection. Upcharge applies, see page 19.

Note:
The Petite Pfister Lounge Seating Collection is Greenguard certified.

Construction

Frame:
Constructed in sections with a combination plywood/hardwood seat and back.

Upholstery:
Petite Pfister lounge seat and back cushion are fully upholstered. Double-needled top stitching on leather upholstery and on thin solid textiles. Single-needled top stitching on heavily ribbed fabrics and multicolor prints. No sag spring deck covered in black cotton textile.

Swivel tablet:
Machined aluminum, post and socket mechanism with black phenolic rectangular tablet; swivels 360°. Tablet dimensions are 10" x 14".

Seat height:
Seat height is measured from the floor to the crown of the seat cushion. Height could vary up to 1/2" depending on leather or textile specified.

Glides:
Nylon, adjustable.

Cushion fill:
Polyester wrap: foam core with polyester fiber wrap for tight, tailored aesthetic.

pattern no.	upcharge	grade A	COM B	C	D	E	F	G	H	I	COL U	V	W	X	Y
1052C-S		\$4,681.	\$5,092.	\$5,489.	\$5,917.	\$6,273.	\$6,529.	\$6,963.	\$7,788.	\$8,633.	\$10,843.	\$12,328.	\$15,486.	\$15,978.	\$16,708.
1053C-S		6,542.	7,118.	7,666.	8,271.	8,765.	9,123.	9,727.	10,878.	12,059.	15,169.	17,232.	21,626.	22,310.	23,327.
1059C-S		1,968.	2,107.	2,235.	2,377.	2,491.	2,575.	2,718.	2,984.	3,260.	4,157.	4,654.	5,710.	5,876.	6,121.
H	n/c														

Approved KnollTextiles Grades/Fabrics

A	B continued	C	C continued
Alignment ‡	Digit	Atlas	Sequin CR
Beacon	Dovetail	Autobahn	Sinclair
Bocce	Ferry	Axiom	Smart
Cat's Cradle	Gala II	Baxter	Spectator
Chance	Grande	Biota ‡	Spot On
Common Ground ‡	Grandview	Cairo	Star Struck
Commuter Cloth ‡	Holbrook	Charm	Stepping Stones
Cotton Duck	Journey	Circa	Swing
Delite	Keaton	Classic Boucle	Tight Rope
Dristi	Knoll Felt ‡	Dahlia CR	Tilden
Hourglass	Knoll Hopsack ‡	Decade	Tower Grid
Mariner	Ludlow	Dune	Transition
Monarch	Lyric	Durand	Treble CR
Prep	Mini Stitch	Earthwork ‡	Zari CR
Soliloquy	Night Life	Echo	D
Sonnet	Nonchalant CR	Empire Stripe	Compass CR
Stacks	Paradigm	Entourage	Coterie
Trophy	Petal Pusher	Fable CR	Eclat Weave
	Pogo ‡	Fibra	Hologram
B	Pop	Greenwich	Island
Abacus ‡	Prairie	Hudson	Island
Argyle	Prim ‡	Hula Hoop	Masquerade
Bank Shot	Radiance	Kaleidoscope CR	Menagerie
Belize	Ransom	Kora CR	Origins
Betwixt	Ricochet ‡	Lagos	Satellite
Bistro ‡	Roam	Legend CR	Satin Chisel
Boundary ‡	Rush Hour	Lore CR	Tara
Cameo	Soiree	Magnolia	Theory
Chroma ‡	Spark ‡	Metro	Woodland
Chronicle	Spinoff Nuance ‡	Milestone	Zoom
	Spree	Moto CR	E
	Starry Night ‡	Noble	Highland
	Summit	Palisade	Ikat Square
	Sutton	Panache CR	Ikat Stripe
	Synth	Posh	Kampala
	Tabloid	Quark	Katazome
	Venue	Regard CR	Kimono
	Versa	Roundtrip	Luberon
	Vinyl	Sahara	Mamba
	Westwood	Sandpiper	Marquee
	Wide Angle ‡		Meroe
	Zephyr		Sherman
	Zipline		Shima
			Tryst
			Whip



Spinneybeck Leather

U	X
Vicenza ‡	Ducale ‡
Volo ‡	Ducale Velour ‡
V	Y
Acqua ‡	Capri ‡
Andes ‡	Cervo
Embossed Tipped	Copenhagen ‡
España ‡	Cordovan ‡
Hand Tipped	Distressed ‡
Maremma	Lucca
Velluto Pelle ‡	Marissa ‡
W	Portofino
Alaska ‡	Prima ‡
Amazon ‡	Riva ‡
Antique ‡	Saddle ‡
Arizona ‡	Salon ‡
Derby ‡	Torello
Forte ‡	
Lucente ‡	
Sabrina ‡	

‡ Approved for Cal 133 upholstery.

Check with your KnollTextiles or Spinneybeck Representative for changes or additions.

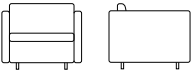
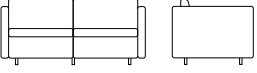
Charles Pfister Lounge Seating

	description	seat h	arm h	w	d	h	textile fabric yds.	req. leather sq. ft.	weight
<p><i>Designer(s):</i> Charles Pfister, 1971</p> 	1051C Standard lounge chair 	16"	24"	33 1/2"	33"	26"	7.2	130	44 lbs.
	1052C Standard settee 	16"	24"	60 1/2"	33"	26"	12.4	224	73 lbs.
	1053C Standard sofa 	16"	24"	87"	33"	26"	17.6	318	101 lbs.
	1059C Standard ottoman 			27 3/4"	27 3/4"	16"	3.8	69	20 lbs.

Order Code

Example: **1053C-MABLK**

1053C Pfister sofa

MABLK Marissa, Black

Specify:

1. Pattern number
2. Cal 133 Fire Code option
3. Textile selection

Ordering Information

Upholstery/COM information:

Prices shown include fabric or leather upholstery. Contact your Knoll representative for colors. Only approved KnollTextiles and Spinneybeck leathers may be ordered.

Customer's Own Material is available pending approval. Non-railroad COM fabrics will require additional yardage. For approval requirements, processing instructions and ordering information please see page 18.

Cal 133 Fire Code#:

Pfister lounge seating complies with the California Technical Bulletin 133 standard if upholstered in Cal 133 approved upholstery. Specify suffix -C at end of pattern number and suffix -133 at end of textile selection. Upcharge applies, see page 19.

Maintenance:

To fluff standard Pfister cushions, turn cushion upside down occasionally. See also pages 28-29.

Note:

The Pfister Lounge Seating Collection is Greenguard certified.

Construction

Frame:

Constructed in sections with a combination plywood/hardwood seat and back.

Upholstery:

Pfister lounge seat and back cushion are fully upholstered. Double-needled top stitching on leather upholstery and on thin solid textiles. Single-needled top stitching on heavily ribbed fabrics and multicolor prints. No sag spring deck covered in black cotton textile.

Seat height:

Seat height is measured from the floor to the crown of the seat cushion. Height could vary up to 1/2" depending on leather or textile specified.

Glides:

Nylon, adjustable.

Cushion fill:

Polyester wrap: foam core with polyester fiber wrap for tight, tailored aesthetic.

pattern no.	grades													
	A	B	C	D	E	F	G	H	I	U	V	W	X	Y
1051C	\$3,340.	\$3,607.	\$3,864.	\$4,143.	\$4,371.	\$4,539.	\$4,817.	\$5,354.	\$5,906.	\$7,381.	\$8,348.	\$10,393.	\$10,713.	\$11,189.
1052C	5,906.	6,368.	6,806.	7,288.	7,687.	7,969.	8,456.	9,377.	10,321.	12,881.	14,542.	18,072.	18,620.	19,437.
1053C	8,275.	8,931.	9,553.	10,241.	10,803.	11,206.	11,895.	13,204.	14,545.	18,225.	20,580.	25,592.	26,368.	27,533.
1059C	2,485.	2,630.	2,765.	2,912.	3,032.	3,119.	3,270.	3,550.	3,839.	4,799.	5,308.	6,393.	6,565.	6,816.

Approved KnollTextiles Grades/Fabrics

A	B continued	C	C continued
Alignment ‡	Digit	Atlas	Sequin CR
Beacon	Dovetail	Autobahn	Sinclair
Bocce	Ferry	Axiom	Smart
Cat's Cradle	Gala II	Baxter	Spectator
Chance	Grande	Biota ‡	Spot On
Common Ground ‡	Grandview	Cairo	Star Struck
Commuter Cloth ‡	Holbrook	Charm	Stepping Stones
Cotton Duck	Journey	Circa	Swing
Delite	Keaton	Classic Boucle	Tight Rope
Dristi	Knoll Felt ‡	Dahlia CR	Tilden
Hourglass	Knoll Hopsack ‡	Decade	Tower Grid
Mariner	Ludlow	Dune	Transition
Monarch	Lytic	Durand	Treble CR
Prep	Mini Stitch	Earthwork ‡	Zari CR
Soliloquy	Night Life	Echo	D
Sonnet	Nonchalant CR	Empire Stripe	Compass CR
Stacks	Paradigm	Entourage	Coterie
Trophy	Petal Pusher	Fable CR	Eclat Weave
	Pogo ‡	Fibra	Hologram
B	Pop	Greenwich	Island
Abacus ‡	Prairie	Hudson	Island
Argyle	Prim ‡	Hula Hoop	Masquerade
Bank Shot	Radiance	Kaleidoscope CR	Menagerie
Belize	Ransom	Kora CR	Origins
Betwixt	Ricochet ‡	Lagos	Satellite
Bistro ‡	Roam	Legend CR	Satin Chisel
Boundary ‡	Rush Hour	Lore CR	Tara
Cameo	Soiree	Magnolia	Theory
Chroma ‡	Spark ‡	Metro	Woodland
Chronicle	Spinoff Nuance ‡	Milestone	Zoom
	Spree	Moto CR	E
	Starry Night ‡	Noble	Highland
	Summit	Palisade	Ikat Square
	Sutton	Panache CR	Ikat Stripe
	Synth	Posh	Kampala
	Tabloid	Quark	Katazome
	Venue	Regard CR	Kimono
	Versa	Roundtrip	Luberon
	Vinyl	Sahara	Mamba
	Westwood	Sandpiper	Marquee
	Wide Angle ‡		Meroe
	Zephyr		Sherman
	Zipline		Shima
			Tryst
			Whip





Spinneybeck Leather

U	X
Vicenza ‡	Ducale ‡
Volo ‡	Ducale Velour ‡
V	Y
Acqua ‡	Capri ‡
Andes ‡	Cervo
Embossed Tipped	Copenhagen ‡
España ‡	Cordovan ‡
Hand Tipped	Distressed ‡
Maremma	Lucca
Velluto Pelle ‡	Marissa ‡
W	Portofino
Alaska ‡	Prima ‡
Amazon ‡	Riva ‡
Antique ‡	Saddle ‡
Arizona ‡	Salon ‡
Derby ‡	Torello
Forté ‡	
Lucente ‡	
Sabrina ‡	

‡ Approved for Cal 133 upholstery.

Check with your KnollTextiles or Spinneybeck Representative for changes or additions.

Charles Pfister Sofa System

	description	seat h	arm h	w	d	h	textile fabric yds.	req. leather sq. ft.	weight
<p><i>Designer(s):</i> Charles Pfister, 1971</p> 	1050C Center module 	16"		27 1/4"	33"	26"	5.2	94	28 lbs.
	1050C-1 End module, arm panel on right side of user 	16"	24"	30 1/8"	33"	26"	6.2	112	36 lbs.
	1050C-2 End module, arm panel on left side of user 	16"	24"	30 1/8"	33"	26"	6.2	112	36 lbs.
	1050C-3 Corner module 	16"	24"	33"	33"	26"	7.0	126	41 lbs.

Order Code

<i>Example:</i>	1050C-3-K349/1
1050C-3	Pfister corner module
K349/1	Alignment, Sand

Specify:

1. Pattern number
2. Cal 133 Fire Code option
3. Textile selection

Ordering information

Upholstery/COM information:
Prices shown include fabric or leather upholstery. Contact your Knoll representative for colors. Only approved Knoll Textiles and Spinneybeck leathers may be ordered. Note: Non-railroad COM fabrics will require additional yardage.

Customer's Own Material is available pending approval. For approval requirements, processing instructions and ordering information please see page 18.

Note:
Modules shipped with unupholstered sides unless specified. For upholstered sides, contact your Knoll representative for pricing. All modules shipped knocked-down (KD), assembly required.

Cal 133 Fire Code ♣ :
The Pfister Collection complies with the California Technical Bulletin 133 standard if upholstered in Cal 133 approved upholstery. Specify polyester fiber wrap and suffix -C at end of pattern number and suffix -133 at end of textile selection. Upcharge applies, see page 18.

Seat height:
Seat height is measured from the floor to the crown of the seat cushion. Height could vary up to 1/2" depending on leather or textile specified.

Maintenance:
To fluff cushions, turn cushion upside down occasionally. See also pages 28-29.

Note:
The Pfister Sofa System is Greenguard certified.

Construction

Frame:
Constructed in sections with a combination plywood/hardwood seat and back.

Upholstery:
Pfister sofa system cushions are fully upholstered. Coverings are upholstered on both sides in fabric or leather. Double-needled top stitching on leather upholstery and thin solid textiles. Single-needled top stitching on heavily ribbed fabrics and multicolor prints. No sag spring deck covered in black cotton textile.

Cushion fill:
Polyester wrap: foam core with polyester fiber wrap for tight, tailored aesthetic.

Glides:
Nylon, adjustable.

pattern no.	grades A	COM B	C	D	E	F	G	H	I	COL U	V	W	X	Y
1050C	\$2,547.	\$2,742.	\$2,922.	\$3,127.	\$3,293.	\$3,414.	\$3,616.	\$4,006.	\$4,400.	\$5,597.	\$6,293.	\$7,707.	\$8,005.	\$8,350.
1050C-1	3,160.	3,393.	3,613.	3,858.	4,052.	4,197.	4,436.	4,901.	5,371.	6,843.	7,674.	9,360.	9,711.	10,121.
1050C-2	3,160.	3,393.	3,613.	3,858.	4,052.	4,197.	4,436.	4,901.	5,371.	6,843.	7,674.	9,360.	9,711.	10,121.
1050C-3	3,901.	4,163.	4,409.	4,684.	4,909.	5,069.	5,342.	5,863.	6,395.	8,132.	9,062.	10,960.	11,358.	11,817.

Approved KnollTextiles Grades/Fabrics

A	Alignment ‡ Beacon Bocce Cat's Cradle Chance Common Ground ‡ Commuter Cloth ‡ Cotton Duck Delite Dristi Hourglass Mariner Monarch Prep Soliloquy Sonnet Stacks Trophy	B continued Digit Dovetail Ferry Gala II Grande Grandview Holbrook Journey Keaton Knoll Felt ‡ Knoll Hopsack ‡ Ludlow Lyric Mini Stitch Night Life Nonchalant CR Paradigm Petal Pusher Pogo ‡ Pop Prairie Prim ‡ Radiance Ransom Ricochet ‡ Roam Rush Hour Soiree Spark ‡ Spinoff Nuance ‡ Spree Starry Night ‡ Summit Sutton Synth Tabloid Venue Versa Vinyl Westwood Wide Angle ‡ Zephyr Zipline	C Atlas Autobahn Axiom Baxter Biota ‡ Cairo Charm Circa Classic Boucle Dahlia CR Decade Dune Durand Earthwork ‡ Echo Empire Stripe Entourage Fable CR Fibra Greenwich Hudson Hula Hoop Kaleidoscope CR Kora CR Lagos Legend CR Lore CR Magnolia Metro Milestone Moto CR Noble Palisade Panache CR Posh Quark Regard CR Roundtrip Sahara Sandpiper	C continued Sequin CR Sinclair Smart Spectator Spot On Star Struck Stepping Stones Swing Tight Rope Tilden Tower Grid Transition Treble CR Zari CR	D Compass CR Coterie Eclat Weave Hologram Island Masquerade Menagerie Origins Satelite Satin Chisel Tara Theory Woodland Zoom	E Highland Ikat Square Ikat Stripe Kampala Katazome Kimono Luberon Mamba Marquee Meroe Sherman Shima Tryst Whip
----------	--	--	--	---	--	--





Spinneybeck Leather

U Vicenza ‡ Volo ‡	V Ducale ‡ Ducale Velour ‡
V Acqua ‡ Andes ‡ Embossed Tipped España ‡ Hand Tipped Maremma Velluto Pelle ‡	V Capri ‡ Cervo Copenhagen ‡ Cordovan ‡ Distressed ‡ Lucca Marissa ‡ Portofino Prima ‡ Riva ‡ Saddle ‡ Salon ‡ Torello
W Alaska ‡ Amazon ‡ Antique ‡ Arizona ‡ Derby ‡ Forte ‡ Lucente ‡ Sabrina ‡	

‡ Approved for Cal 133 upholstery.

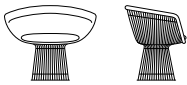
Check with your KnollTextiles or Spinneybeck Representative for changes or additions.

Warren Platner Seating Collection

	description	seat h	w	d	h	frame	textile fabric yds.	req. leather sq ft	weight
<i>Designer(s):</i> Warren Platner, 1962	1715L Lounge chair 	18 1/2"	36 1/2"	25 1/2"	30 1/4"	nickel	4.0	n/a	37 lbs.
		18 1/2"	36 1/2"	25 1/2"	30 1/4"	bronze	4.0	n/a	37 lbs.
		18 1/2"	36 1/2"	25 1/2"	30 1/4"	gold	4.0	n/a	37 lbs.
<i>Award(s):</i> 1966 American Institute of Architects International Award	1725A Arm chair 	19"	26 1/2"	22"	28 3/4"	nickel	1.8	35	21 lbs.
		19"	26 1/2"	22"	28 3/4"	bronze	1.8	35	21 lbs.
		19"	26 1/2"	22"	28 3/4"	gold	1.8	35	21 lbs.
	1719Y Stool 	22 3/4"	15 1/4"		22 3/4"	nickel	1.1	20	12 lbs.
		22 3/4"	15 1/4"		22 3/4"	bronze	1.1	20	12 lbs.
		22 3/4"	15 1/4"		22 3/4"	gold	1.1	20	12 lbs.

Order Code

<i>Example:</i>	1725A-N-H800/2
1725A	Platner arm chair
N	Nickel frame
H800/2	Cato, Sand

Note:
Platner lounge seating is part of a collection. Please refer to Platner Easy Chair and Ottoman on page 216 and Platner tables on page 366.

Specify:

1. Pattern number
2. Frame finish
3. Textile selection

Ordering Information

Frame:
Metallic Bronze (suffix BRM)
Polished Nickel (suffix N)
18k Gold Plated (suffix GLD)

Upholstery/COM information:
Prices shown include fabric or leather upholstery. Contact your Knoll representative for colors. Only approved KnollTextiles and Spinneybeck leathers may be ordered.

Customer's Own Material is available pending approval. For approval requirements, processing instructions and ordering information please see page 18.

Cal 133 Fire Code ♣:
The Platner Seating Collection complies with the California Technical Bulletin 133 standard if upholstered in Cal 133 approved upholstery. Specify suffix -C at end of pattern number and suffix -133 at end of textile selection. Upcharge applies, see page 19.

Maintenance:
See pages 28-29.

Note:
The Platner Seating Collection is Greenguard certified.

Construction

Frame:
Forms created by vertical steel wire rods welded to circular horizontal and edge-framing rods. Finish in bright nickel with clear lacquer protection, painted bronze metallic, or plated in 18k gold.

Base:
Clear plastic extrusion ring for smooth bottom surface.

Upholstery:
Molded fiberglass shell with molded latex foam cushion. Cushions with latex core and zipper cover attach to seat with Velcro.

pattern no.	grades										COL			
	A	B	C	D	E	F	G	H	I	U	V	W	X	Y
1715L-N(-)	\$8,030.	\$8,148.	\$8,264.	\$8,387.	\$8,489.	\$8,562.	\$8,689.	\$8,927.	\$9,102.					
1715L-BRM(-)	8,484.	8,603.	8,718.	8,842.	8,945.	9,018.	9,142.	9,382.	9,555.					
1715L-GLD(-)	10,709.	10,795.	10,891.	11,005.	11,163.	11,255.	11,416.	11,523.	11,843.					
1725A-N(-)	4,609.	4,663.	4,714.	4,770.	4,817.	4,850.	4,907.	5,015.	5,093.	5,412.	5,619.	6,040.	6,127.	6,230.
1725A-BRM(-)	4,976.	5,029.	5,082.	5,138.	5,185.	5,219.	5,273.	5,382.	5,461.	5,782.	5,986.	6,409.	6,498.	6,598.
1725A-GLD(-)	6,720.	6,759.	6,802.	6,854.	6,925.	6,966.	7,038.	7,087.	7,231.	10,344.	10,490.	10,787.	10,849.	10,921.
1719Y-N(-)	2,602.	2,633.	2,664.	2,698.	2,726.	2,748.	2,782.	2,848.	2,896.	3,055.	3,173.	3,415.	3,465.	3,524.
1719Y-BRM(-)	2,716.	2,749.	2,779.	2,814.	2,842.	2,862.	2,898.	2,962.	3,012.	3,171.	3,288.	3,530.	3,580.	3,639.
1719Y-GLD(-)	3,898.	3,922.	3,948.	3,980.	4,023.	4,049.	4,093.	4,122.	4,210.	5,957.	6,040.	6,210.	6,246.	6,287.

Approved KnollTextiles Grades/Fabrics

A	E continued	C continued	D
Beacon	Roam	Greenwich	Compass CR *
Boce	Rush Hour **	Hudson	Eclat Weave
Cat's Cradle	Soiree	Hula Hoop	Hologram
Chance	Spark	Kaleidoscope CR *	Island **
Common Ground	Spinoff Nuance	Kora CR **	Menagerie
Commuter Cloth	Spree	Lagos **	Origins
Delite	Starry Night	Legend CR *	Satellite *
Dristi	Summit	Magnolia	Satin Chisel *
Hourglass	Synth	Metro	Theory
Mariner	Venue	Milestone	Woodland **
Monarch	Westwood	Moto CR **	
Soliloquy	Wide Angle	Noble	E
Sonnet	Zephyr	Palisade	Highland
Stacks	Zipline	Panache CR *	Ikat Square
Trophy		Posh	Ikat Stripe
	C	Quark	Kampala
	Atlas **	Regard CR **	Katazome
	Autobahn *	Roundtrip	Kimono
	Axiom	Sahara **	Luberon
	Bank Shot	Sandpiper *	Mamba
	Belize	Sequin CR	Marquee
	Betwixt	Sinclair	Meroe
	Bistro **	Smart	Sherman **
	Boundary	Circa	Shima
	Cameo	Classic Boucle	Tryst
	Chroma	Dahlia CR	Whip
	Chronicle	Dune	F
	Close Knit *	Durand **	Atelier
	Dovetail	Earthwork	Biscayne
	Ferry	Echo	Century
	Gala II	Enmesh	Coco
	Grande	Entourage	Cornaro
	Grandview	Fable CR	Eclipse
	Holbrook	Fibra	Glider
	Journey		Icon
	Keaton		Intrigue
	Knoll Felt ‡		Liberty
	Knoll Hopsack ‡		Mod Plaid
	Ludlow		Rivington
	Lyric		Soon **
	Mini Stitch		Topography
	Night Life		Totem
	Paradigm		Tweed Frieze
	Petal Pusher **		
	Pogo		
	Pop		
	Prim		
	Radiance		
	Ransom		
	Ricochet		



Spinneybeck Leather

U	X
Vicenza **	Ducale **
Volo **	Ducale Velour **
V	Y
Acqua **	Capri **
Andes **	Cervo **
Embossed	Copenhagen **
Tipped **	Cordovan **
España **	Distressed **
Hand Tipped **	Lucca
Maremma **	Marissa **
Velluto Pelle **	Portofino **
	Prima **
W	Riva **
Alaska **	Saddle **
Amazon **	Salon **
Antique **	Torollo **
Arizona **	
Derby **	
Forte **	
Lucente	
Sabrina **	

* Approved for 1719Y stool only
 ** Not approved for 1715L lounge chair
 ‡ Approved for Call133 upholstery

Check with your KnollTextiles or Spinneybeck Representative for changes or additions.

Warren Platner Easy Chair and Ottoman

	description	seat h	w	d	h	frame	textile fabric yds.	weight
Designer(s): Warren Platner, 1962 	1705L Easy Chair 	18 ^{3/4} "	39 ^{7/8} "	37"	38 ^{3/4} "	nickel	7.0	n/a
	1709Y Ottoman 	–	26 ^{3/4} "	26 ^{3/4} "	16 ^{7/8} "	nickel	2.75	n/a

Order Code

<i>Example:</i>	1705L-N-H800/2
1705L	Platner Easy chair
N	Nickel frame
H800/2	Cato, Sand

Note:
Platner Easy Chair and Ottoman is part of a collection. Please refer to Platner Seating Collection on page 214 and Platner tables on page 366.

Specify:

1. Pattern number
2. Frame finish
3. Textile selection

Ordering Information

Frame:
Polished Nickel (suffix N)

Upholstery/COM information:
Prices shown include fabric upholstery. Contact your Knoll representative for colors. Only approved KnollTextiles may be ordered. All textiles will be cut railroad.

Customer's Own Material is available pending approval. For approval requirements, processing instructions and ordering information please see page 18.

Cal 133 Fire Code#:
The Easy Chair and Ottoman comply with the California Technical Bulletin 133 standard if upholstered in Cal 133 approved upholstery. Specify suffix -C at end of pattern number and suffix -133 at end of textile selection. Upcharge applies, see page 19.

Maintenance:
See pages 28-29.

Note:
The Platner Easy Chair and Ottoman are Greenguard certified.

Construction

Construction:
Hand bent vertical steel wire rods welded to circular horizontal and edge-framing rods. Finish in bright nickel with a clear lacquer protection. Clear plastic extrusion ring for a smooth bottom surface. Molded fiberglass shell with highly resilient molded urethane foam cushions. Seat and ottoman cushion utilize the same highly resilient molded urethane foam cushion.

pattern no.	grades A	COM B	C	D	E	F	G	H	I
1705L-N	\$12,565.	\$12,727.	\$12,881.	\$13,051.	\$13,190.	\$13,291.	\$13,461.	\$13,786.	\$14,024.
1709Y-N	3,444.	3,508.	3,569.	3,637.	3,690.	3,730.	3,797.	3,924.	4,019.







Approved KnollTextiles Grades/Fabrics

A	B continued	C continued	D	G	I
Bocce	Roam	Hudson	Eclat Weave	Arabella	Canaan
Cat's Cradle	Soiree	Hula Hoop	Hologram	Gibson	Cato
Common Ground ‡	Spark	Metro	Menagerie	Hampshire	Diamond Days
Commuter Cloth	Spree	Milestone	Origins	Haze	Dynamic
Delite	Starry Night ‡	Posh	Theory	Kamani	Gates
Hourglass	Summit	Quark		Kinabalu	Jaipur
Monarch	Zipline	Regard CR	E	Kingston	Knoll Velvet
Sonnet		Roundtrip	Highland	Melange	North Island ‡
Stacks	C	Smart	Ikat Square	Metallic Gloss	Olema
Trophy	Biota	Star Struck	Ikat Stripe	Sablon	Piper
	Charm	Swing	Kampala	Serendipity	Rutledge
B	Circa	Tight Rope	Katazome	Spencer	Vermeer
Abacus	Classic Boucle ‡	Tower Grid	Kimono	Straie Stripe	Walker
Argyle	Dahlia CR	Transition	Luberon	Ultrasede	Worth
Bank Shot ‡	Dune	Treble CR	Mamba	Utrillo	Zimba
Belize	Earthwork		Marquee		
Betwixt	Echo		Meroe	H	
Boundary	Fibra		Shima	Arno	
Cameo	Greenwich		Whip	Bavaria	
Chronicle				Constance	
Dovetail			F	Firefly	
Ferry			Atelier	Gezelle	
Grande			Biscayne	Magritte	
Grandview			Coco	Rosemond	
Holbrook			Eclipse		
Journey			Glider		
Keaton			Icon		
Knoll Felt ‡			Intrigue		
Knoll Hopsack ‡			Liberty		
Ludlow			Mod Plaid		
Lyric			Rivington		
Mini Stitch			Topography		
Night Life ‡					
Paradigm					
Petal Pusher					
Pogo					
Prim					
Radiance					
Ransom					

‡ Approved for Cal 133 upholstery

Charles Pollock

Executive Conference Arm and Armless Chairs

	description	seat h	arm h	w	d	h	textile fabric yds.	req. leather sq. ft.	weight
Designer(s): Charles Pollock, 1963  	12A-(1, 2, 3 or 4)-D5G-H Arm chair, swivel/tilt, pneumatic height, seat height adjustment  	18"-23"	24"-29"	26 1/4"	28 1/4"	31"-36"	1.1	20	44 lbs. 44 lbs.
	12C-(1, 2, 3 or 4)-D5G-H Armless chair, swivel/tilt, pneumatic height, seat height adjustment  	18"-23"		23 1/2"	28 1/4"	31"-36"	1.1	20	41 lbs. 41 lbs.
	R Optional casters for hard floors (substitute -R for -H in pattern number)								
	1250BUTTON Replacement buttons (specify upholstery)								

Order Code

<i>Example:</i>	12A-1-D5G-H-AM3030
12A	Pollock arm chair
1	Polished aluminum frame/stainless steel base top caps
D5G	Swivel/tilt control with pneumatic seat height adjustment
H	Hard-wheel casters
AM3030	Amazon, Bossa Nova

Specify:

1. Pattern number
2. Frame/base top cap finish
3. Cal 133 Fire Code option
4. Textile selection

Ordering Information

Frame/base top cap finishes:
 Polished aluminum/stainless steel (suffix 1)
 Satin anodized aluminum/brushed stainless steel (suffix 2)
 Black anodized aluminum/black epoxy (suffix 3)
 Black anodized aluminum/stainless steel (suffix 4)

Upholstery/COM information:
 Prices shown include fabric or leather upholstery. Contact your Knoll representative for colors. Only approved Knoll Textiles and Spinneybeck leathers may be ordered.

Customer's Own Material is available pending approval. For approval requirements, processing instructions and ordering information please see page 18.

Maintenance:
 See pages 28-29.

Cal 133 Fire Code:
 The Pollock Chair complies with the California Technical Bulletin 133 standard if upholstered in Cal 133 approved upholstery. Specify suffix -C at end of pattern number and suffix -133 at end of textile selection. Upcharge applies, see page 19.

Note:
 The Pollock Executive Conference Arm and Armless Chair is Greenguard certified.

Construction

Outer shell:
 Integrally colored, black textured polypropylene.

Frame:
 Extruded aluminum with polished, satin or black anodized finish. Steel support plate spans the width of the seat cushion.

Upholstery:
 Multi-density urethane foam (4 1/2" maximum thickness); button tufting on fabric and leather detail.

Arms:
 Seamless, black phenolic plastic.

Column cover:
 Polypropylene on pneumatic seat height models; steel with epoxy finish on mechanical seat height models.

Base:
 Steel armature with epoxy finish; polished stainless or black epoxy finished top caps. Standard five-star design.

Standard casters:
 Hard wheel casters standard.

Controls:
 360° swivel; tilt with tilt tension and pneumatic seat height adjustment.

Replacement buttons:
 Set of 6 buttons for one chair.

pattern no.	grades										COL			
	A	B	C	D	E	F	G	H	I	U	V	W	X	Y
12A-(1 or 2)-D5G-H	\$2,856.	\$2,903.	\$2,946.	\$2,981.	\$3,009.	\$3,035.	\$3,064.	\$3,135.	\$3,265.	\$3,386.	\$3,540.	\$3,891.	\$3,952.	\$3,989.
12A-(3 or 4)-D5G-H	2,613.	2,659.	2,704.	2,738.	2,767.	2,793.	2,820.	2,892.	3,024.	3,144.	3,299.	3,647.	3,711.	3,748.
12C-(1 or 2)-D5G-H	2,623.	2,667.	2,711.	2,740.	2,769.	2,794.	2,820.	2,891.	3,016.	3,135.	3,282.	3,618.	3,680.	3,713.
12C-(3 or 4)-D5G-H	2,393.	2,436.	2,478.	2,509.	2,538.	2,563.	2,589.	2,659.	2,785.	2,904.	3,049.	3,388.	3,451.	3,481.
R	n/c													
1250BUTTON- ()	55.	55.	55.	55.	55.	55.	55.	55.	55.	81.	81.	81.	81.	81.

Approved KnollTextiles Grades/Fabrics

A	B	C	D	E
Beacon	Paradigm	Fibra	Compass CR	Atelier
Bocce	Petal Pusher	Greenwich	Coterie	Biscayne
Cat's Cradle	Pogo ♣	Hudson	Eclat Weave	Century
Common Ground ♣	Pop	Hula Hoop	Hologram	Coco
Commuter Cloth ♣	Prairie	Kora CR	In The Loop	Cornaro
Cotton Duck	Prim	Lagos	Island	Eclipse
Delite	Radiance	Legend CR	Masquerade	Glider
Dristi	Ransom	Lore CR	Menagerie	Icon
Hourglass	Ricochet ♣	Magnolia	Origins	Intrigue
Mariner	Roam	Metro	Satellite	Liberty
Monarch ♣	Rush Hour	Milestone	Satin Chisel	Mod Plaid
Prep ♣	Soiree	Moto CR	Tara	Rivington
Presto ♣	Spark ♣	Noble	Theory	Topography
Soliloquy	Spinoff Nuance ♣	Palisade	Woodland	Totem
Sonnet	Spree	Panache CR	Zoom	Tweed Frieze
Stacks	Starry Night ♣	Quark		
Trophy	Summit	Regard CR	E	G
	Sutton	Roundtrip	Highland	Arabella
B	Synth	Sequin CR	Ikat Square	Arber
Abacus ♣	Tabloid	Sinclair	Ikat Stripe	Djenne
Argyle	Venue	Smart	Kampala	Gibson
Bank Shot ♣	Versa	Spectator	Katazome	Hampshire
Belize	Vinyl	Spot On	Kimono	Haze
Betwixt ♣	Westwood	Star Struck	Luberon	Kamani
Bistro ♣	Wide Angle ♣	Stepping Stones	Mamba	Kinabalu
Boundary	Zephyr	Swing	Marquee	Kingston
Cameo	Zipline	Tight Rope	Meroe	Melange
Chance		Tower Grid	Sherman	Metallic Gloss
Chroma ♣	C	Tilden	Shima	Sablon
Chronicle	Autobahn	Transition ♣	Tryst	Serendipity
Close Knit	Axiom	Treble CR	Whip	Spencer
Digit	Baxter	Vibe		Straie Stripe
Dovetail ♣	Biota ♣	Zari CR		Ultrasuede ♣
Ferry	Cairo			Utrillo
Gala II	Charm			
Grande	Circa			
Grandview	Classic Boucle			
Holbrook	Dahlia CR			
Journey	Durand			
Keaton	Earthwork ♣			
Knoll Felt ♣	Echo			
Knoll Hopsack ♣	Empire Stripe			
Ludlow	Enmesh ♣			
Lyric	Entourage			
Mini Stitch ♣	Fable CR			
Night Life				
Nonchalant CR				

Spinneybeck Leather



U	X
Vicenza ♣	Ducale ♣
Volo ♣	Ducale Velour ♣
V	Y
Acqua ♣	Capri ♣
Andes ♣	Cervo
Embossed Tipped	Copenhagen ♣
España ♣	Cordovan ♣
Hand Tipped	Distressed
Velluto Pelle ♣	Lucca
W	Marissa ♣
Alaska ♣	Portofino
Amazon ♣	Prima ♣
Antique ♣	Riva ♣
Arizona ♣	Torello
Derby ♣	
Forte ♣	
Lucente	
Sabrina ♣	

♣ Approved for Cal 133 upholstery.

Check with your KnollTextiles or Spinneybeck Representative for changes or additions.

Charles Pollock

Arm Chair

	description	seat h	arm h	w	d	h	weight
<p><i>Designer(s):</i> Charles Pollock, 1960</p> 	<p>657 Arm Chair</p> 	16 1/4"	22 3/4"	25"	26"	27 3/4"	32 lbs.

Order Code

<i>Example:</i>	657-BL-PT
657	arm chair
BL	belting leather
PT	Portofino

Specify:

1. Pattern number
2. Belting leather selection
3. Cushion upholstery selection

Ordering Information

Frame finishes:
Chrome/black

Sling upholstery:
Spinneybeck Belting Leather (suffix BL__)

Seat pad:
Spinneybeck Portofino (suffix PT__)
Spinneybeck Hand Tipped (suffix HT__)

Upholstery note:
No Customer's Own Materials can be used.

Replacement slings:
Knoll does not recommend replacement slings. This procedure requires the chair to be disassembled and rebuilt, a complex and time consuming process.

Maintenance:
See pages 28-29.

Please ask your Spinneybeck Representative for samples of the belting leather.

pattern no.

657-(BL_) - (PT_, HT_)

\$3,605.

Construction

Frame:

Tubular steel legs, polished chrome finish. Cast aluminum arms and stretchers, black painted finish. Stamped steel glides.

Upholstery:

Belting leather sling. Cushion is urethane foam upholstered in Portofino or Hand Tipped leather.

Carlos Riart

Riart Rocker

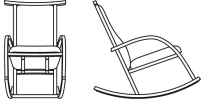
	description	seat h	arm h	w	d	h	textile fabric yds.	req. leather sq. ft.	weight
<p><i>Designer(s):</i> Carlos Riart, 1982</p> 	<p>790 Riart Rocker</p> 	21"	24 1/2"	24 1/4"	42 1/2"	38 1/4"	2	38	25 lbs.

Order Code

<i>Example:</i>	790-LWT-K1320/6
790	Riart Rocker
LWT	Light Walnut
K1320/6	Cornaro, Meadow

Specify:

1. Pattern number
2. Finish selection
3. Textile selection

Ordering Information

Walnut with light lacquer finish:
Light Walnut (suffix LWT)

Medium Figured English Sycamore:
Sycamore (suffix S515)

Upholstery/COM information:
Prices shown include fabric or leather upholstery. Contact your Knoll representative for colors. Only approved Knoll Textiles and Spinneybeck leathers may be ordered.

Customer's Own Material is available pending approval. For approval requirements, processing instructions and ordering information please see page 18.

Maintenance:
See pages 23-28.

Note:
Carlos Riart's signature is engraved in each chair.

The Riart Rocker is Greenguard approved.

Construction

Frame:
Solid lumber frame construction with laminated runners and arms.

Upholstery:
High density, polyurethane foam used in all upholstered areas. Elastic seat belt suspension.

Inlays:
Mother of Pearl inlays for product specified in Light Walnut. Ebony inlays for product in Sycamore.

pattern no.	grades A	COM B	C	D	E	F	G	H	I	COL U	V	W	X	Y
790-(-)(-)	\$5,135.	\$5,183.	\$5,228.	\$5,277.	\$5,318.	\$5,348.	\$5,399.	\$5,493.	\$5,564.	\$6,105.	\$6,286.	\$6,653.	\$6,729.	\$6,818.

Approved KnollTextiles Grades/Fabrics

A Cat's Cradle Chance Common Ground Hourglass Mariner Presto Sonnet	B continued Nonchalant CR Petal Pusher Pogo Pop Prairie Ricochet Spinoff Nuance Spark Venue Vinyl Westwood Zephyr	C continued Kaleidoscope CR Lore CR Palisade Panache CR Posh Quark Regard CR Roundtrip Sahara Sandpiper Sequin CR Smart Spot On Swing Tilden Transition Treble CR Vibe Zari CR	D Compass CR Eclat Weave Hologram Masquerade Theory Zoom	E Highland Katazome Shima	F Atelier Calais Cotton Velvet Coco Cornaro Eclipse Icon Intrigue Rivington Shima Tweed Frieze
---	--	--	---	---	--

Spinneybeck Leather

U Vicenza Volo	V Acqua Andes España Velluto Pelle	W Alaska Antique Arizona Forte Lucente Sabrina	Y Copenhagen Cordovan Marissa Prima Riva Salon
-----------------------------	---	---	---

Check with your KnollTextiles or Spinneybeck Representatives for changes or additions.

Joe Ricchio Joe™ Chair

Designer(s):
Joe Ricchio

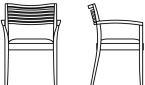

description	seat h	arm h	w	d	h	textile fabric yds.	req. leather sq. ft.	weight	finish
48A Joe arm chair	19"	26"	24"	22"	32"	0.8	14.5	16 lbs.	other stains
	19"	26"	24"	22"	32"	0.8	14.5	16 lbs.	maple, ebonized
48R Seat basket replacement for 48A						0.8	13		

Order Code

<i>Example:</i>	48A-BN-K224/1
48A	Joe arm chair
BN	Natural Beech
K224/1	Wide Angle, Castor

Specify:

1. Pattern number
2. Finish
3. Cal 133 fire code option
4. Textile selection

Ordering Information

Maple:
Clear Maple (suffix KC)

Beech frame stains:
Beech (suffix B311)
Bronzed Cherry (suffix B312A)
Burnt Walnut (suffix B313)
Deep Red Mahogany (suffix B328)
Ebonized (suffix BE)
Light Cherry (suffix B315)
Medium Cherry (suffix B319)
Medium Red Mahogany (suffix BR)
Medium Walnut (suffix B323)
Natural Beech (suffix BN)
Warm Brown Walnut (suffix J)

Upholstery/COM information:
Prices shown include fabric or leather upholstery. Contact your Knoll representative for colors. Only approved KnollTextiles and Spinneybeck leathers may be ordered.

Customer's Own Material is available pending approval. For approval requirements, processing instructions and ordering information please see page 18.

KnollStudio wood finishes:
KnollStudio wood finishes complement a large variety of KnollStudio veneer and Knoll Office veneer finishes. To select correct complementary finish, please refer to KnollStudio Wood Finish Matrix on page 25. If no complementary standard finish is available, please refer to custom finish policy below.

Custom finishes:
Complementary finishes to any KnollStudio or Knoll Office wood finish are available at no upcharge. To complement non-Knoll wood veneer or lumber finishes, a one-time, non-negotiable net upcharge of \$618 applies. Re-orders are at no upcharge. Please contact your KnollStudio representative, dealer or Customer Service associate for complete custom finish information and Order Code. Minimum order quantity for any custom finish order: 4 chairs.

Cal 133 Fire Code#:
The Joe Chair complies with the California Technical Bulletin 133 standard if upholstered in Cal 133 approved upholstery. Specify suffix -C at end of pattern number and suffix -133 at end of textile selection. Upcharge applies, see page 19.

Certified Wood:
Chairs manufactured using FSC certified hardwoods are available through Custom Product Development. Extended leadtime and upcharge apply.

Maintenance:
See pages 28-29.

Note:
The Joe Chair is Greenguard certified.

Construction

Frame:
Select maple hardwood in clear or beech hardwood in stained finish.

Upholstered seat:
Elastic seat belt suspension, high resilient foam. Seat basket is 1.25" thick.

pattern no.	grades													
	A	B	C	D	E	F	G	H	I	U	V	W	X	Y
48A-()	\$1,108.	\$1,134.	\$1,159.	\$1,186.	\$1,208.	\$1,222.	\$1,247.	\$1,301.	\$1,339.	\$1,465.	\$1,557.	\$1,747.	\$1,785.	\$1,830.
48A-(KC, BE)	1,277.	1,302.	1,327.	1,353.	1,376.	1,389.	1,416.	1,471.	1,508.	1,632.	1,726.	1,916.	1,954.	1,999.
48R-()	225.	252.	276.	305.	327.	342.	374.	420.	464.	597.	692.	891.	932.	979.

Approved KnollTextiles Grades/Fabrics

A	Alignment ‡	Analogy	Beacon	Bocce	Cat's Cradle	Chance	Common Ground ‡	Commuter Cloth ‡	Cotton Duck ‡	Dristi	Foil Rap	Heavy Metal	Hourglass	Mariner	Metaphor	Monarch ‡	Prep ‡	Presto ‡	Soliloquy	Sonnet	Stacks	Trophy										
B	Abacus ‡	Argyle	Backdrop	Bank Shot	Belize	Betwixt ‡	Bistro ‡	Boundary ‡ ‡	Cameo	Chroma ‡	Chronicle	Close Knit	Digit ‡	Digital Tape	Dovetail ‡	Fast Forward	Ferry															
C	Atlas	Autobahn ‡	Axiom	Baxter	Biota ‡	Cairo	Charm ‡	Circa	Classic Boucle	Dahlia CR	Decade	Dune	Durand	Earthwork ‡	Echo	Empire Stripe	Enmesh ‡	Entourage	Fable CR	Fibra	Greenwich	Hudson	Hula Hoop ‡	Kaleidoscope CR	Kora CR	Lagos	Legend CR	Lore CR	Metro	Milestone	Moto CR ‡	Noble
C	Palisade	Panache CR	Posh	Quark	Regard CR	Roundtrip	Sequin CR	Sahara	Sandpiper	Sinclair	Smart	Star Struck ‡	Stepping Stones	Spectator	Spot On	Swing	Tight Rope	Tilden	Tower Grid	Transition ‡	Treble CR	Vibe	Zari CR									
D	Compass CR	Coterie	Eclat Weave	Hologram ‡	In The Loop	Island	Masquerade	Menagerie	Origins	Satellite ‡	Satin Chisel ‡	Theory	Woodland	Zoom																		

Spinneybeck Leather





E	Ikat Square	Ikat Stripe	Kampala	Katazome	Kimono	Luberon	Mamba	Marquee	Meroe	Sherman	Shima	Tryst	Whip									
F	Atelier	Biscayne	Calais Cotton	Velvet	Century	Coco	Cornaro	Eclipse	Glider	Icon ‡	Intrigue	Mod Plaid	Rivington	Soon	Topography	Totem	Tweed Frieze					
G	Arabella	Arber	Djenne	Gibson	Hampshire	Haze																
G	Kamani	Kinabalu	Sablon	Serendipity	Spencer	Ultrasuede ‡	Utrillo															
H	Arno	Bavaria	Constance	Firefly	Gezelle	Magritte	Rosemond															
I	Aswan	Byron	Canaan	Cato	Cummings	Glider	Dynamic	Gates	Jaipur	Knoll Velvet	Mepal	North Island	Olema	Piper	Ravello	Rutledge	Sandis	Tudor	Vermeer	Walker	Worth	Zimba
U	Vicenza ‡	Volo ‡																				
V	Acqua ‡	Andes ‡	Embossed Tipped	España ‡	Hand Tipped ‡	Maremma ‡	Velluto Pelle ‡															
W	Alaska ‡	Amazon ‡	Antique ‡	Arizona ‡	Derby ‡	Forte ‡	Lucente ‡	Sabrina ‡														
X	Ducale ‡	Ducale Velour ‡																				
Y	Capri ‡	Cervo	Copenhagen ‡	Cordovan ‡	Distressed ‡	Lucca	Marissa ‡	Portofino ‡	Prima ‡	Riva ‡	Saddle ‡	Salon ‡	Torollo									

‡ Approved for Cal 133 upholstery.

Check with your KnollTextiles or Spinneybeck Representative for changes or additions.

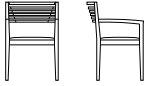
Joe and Linda Ricchio

JR[®] and Ricchio Chair with Upholstered Seat

	description	seat h	arm h	w	d	h	textile fabric yds.	req. leather sq. ft.	weight	finish
<i>Designer(s):</i> Joseph and Linda Ricchio, 1990	37A Arm chair	18"	25 1/4"	21 1/4"	23 1/2"	32 1/4"	0.7	13	17 lbs.	maple, ebonized
		18"	25 1/4"	21 3/4"	23 1/2"	32 1/4"	0.7	13	17 lbs.	other finishes
<i>Award(s):</i> Roscoe, 1991	37C Armless chair	18"		21 1/4"	23 1/2"	32 1/4"	0.7	13	15 lbs.	maple, ebonized
		18"		21 1/4"	23 1/2"	32 1/4"	0.7	13	15 lbs.	other finishes
 	T Thick seat option (add -T to end of pattern number)									
	37R-T Thick seat basket replacement for 37A and 37C						0.7	13		
	37R Seat basket replacement for 37A and 37C						0.7	13		

Order Code

<i>Example:</i>	37A-T-BN-K1320/4
37A	Arm chair
T	Thick seat
BN	Natural Beech
K1320/4	Cornaro, Tabasco

Specify:

1. Pattern number
2. Thick seat option (Ricchio chair only)
3. Finish selection
4. Cal 133 Fire Code option
5. Textile selection

Maple:

Clear Maple (suffix KC)

Beech frame stains:

- Beech (suffix B311)
- Bronzed Cherry (suffix B312A)
- Burnt Walnut (suffix B313)
- Deep Red Mahogany (suffix B328)
- Ebonized (suffix BE)
- Light Cherry (suffix B315)
- Medium Cherry (suffix B319)
- Medium Red Mahogany (suffix BR)
- Medium Walnut (suffix B323)
- Natural Beech (suffix BN)
- Warm Brown Walnut (suffix J)

Ordering Information

Upholstery/COM information:

Prices shown include fabric or leather upholstery. Contact your Knoll representative for colors. Only approved KnollTextiles and Spinneybeck leathers may be ordered.

Customer's Own Material is available pending approval. For approval requirements, processing instructions and ordering information please see page 18.

KnollStudio wood finishes:

KnollStudio wood finishes complement a large variety of KnollStudio veneer and Knoll Office veneer finishes. To select correct complementary finish, please refer to KnollStudio Wood Finish Matrix on page 25. If no complementary standard finish is available, please refer to custom finish policy below.

Custom finishes:

Complementary finishes to any KnollStudio or Knoll Office wood finish are available at no upcharge. To complement non-Knoll wood veneer or lumber finishes, a one-time, non-negotiable net upcharge of \$618 applies. Re-orders are at no upcharge. Please contact your KnollStudio representative, dealer or Customer Service associate for complete custom finish information and Order Code. Minimum order quantity for any custom finish order: 4 chairs.

Cal 133 Fire Code #:

The JR and Ricchio Chairs comply with the California Technical Bulletin 133 standard if upholstered in Cal 133 approved upholstery. Specify suffix -C at end of pattern number and suffix -133 at end of textile selection. Upcharge applies, see page 19.

Certified Wood:

Chairs manufactured using FSC certified hardwoods are available through Custom Product Development. Extended leadtime and upcharge apply.

Maintenance:

See pages 28-29.

Note:

The JR and Ricchio Chair are Greenguard certified.

JR Chair (44A) does not stack.

Construction

Frame:

Select clear maple hardwood in clear or beech hardwood in stained finish. Dowel and mortise and tenon construction.

Upholstered seat:

Injection-molded copolymer plastic seat pan screws into corner blocks of chair frame. Standard seat basket is 1" thick. Thick seat basket option is 2" (Ricchio chair only). Note upcharge above.

Upholstered Seat:

High density, polyurethane foam used in all upholstered areas. Elastic seat belt suspension.

Seat Basket Replacement:

Upholstered seat sits on chair frame. Screws lock basket in place for easy installation or removal. For seat basket replacements for JR chairs ordered prior to February 2007, specify pattern numbers 37R-S. Pricing for 44R will apply.

Finish:

Catalyzed lacquer protective coating. Hand-applied final wax coating.

Glides:

Recessed plastic glides.

pattern no.	upcharge	grades										COL				
		A	B	C	D	E	F	G	H	I	U	V	W	X	Y	
37A-(KC, BE)		\$1,265.	\$1,292.	\$1,312.	\$1,340.	\$1,365.	\$1,378.	\$1,406.	\$1,457.	\$1,495.	\$1,657.	\$1,756.	\$1,948.	\$1,986.	\$2,034.	
37A-()		1,203.	1,229.	1,247.	1,277.	1,301.	1,316.	1,342.	1,396.	1,433.	1,594.	1,693.	1,885.	1,924.	1,970.	
37C-(KC, BE)		1,187.	1,214.	1,237.	1,264.	1,288.	1,300.	1,329.	1,381.	1,418.	1,582.	1,678.	1,869.	1,910.	1,956.	
37C-()		1,129.	1,158.	1,178.	1,206.	1,230.	1,242.	1,271.	1,324.	1,361.	1,522.	1,621.	1,812.	1,851.	1,898.	
T	27.															
37R-T-()		267.	295.	317.	340.	364.	381.	408.	460.	497.	660.	757.	950.	990.	1,036.	
37R-()		240.	268.	290.	313.	337.	354.	381.	434.	471.	633.	730.	923.	963.	1,009.	

Approved KnollTextiles Grades/Fabrics

A	B continued	C	C continued
Alignment ‡	Forza	Atlas	Smart
Analogy	Gala II	Autobahn ‡	Star Struck ‡
Beacon	Grande	Axiom	Stepping Stones
Bocce	Grandview	Baxter	Spectator
Cat's Cradle	Holbrook	Biota ‡	Swing
Chance	Journey	Cairo	Tight Rope
Common Ground ‡	Knoll Felt	Charm ‡	Tilden
Commuter Cloth ‡	Knoll Hopsack	Circa	Tower Grid
Cotton Duck ‡	Ludlow	Classic Boucle	Transition ‡
Dristi	Lyric ‡	Dahlia CR	Treble CR
Foil Rap	Keaton	Decade	Vibe
Heavy Metal	Mini Stitch ‡	Dune	Zari CR
Hourglass	Night Life	Durand	D
Mariner	Nonchalant CR	Earthwork ‡	Compass CR
Metaphor	Odeon	Echo	Coterie
Monarch ‡	Paradigm	Empire Stripe	Eclat Weave
Prep ‡	Petal Pusher	Enmesh ‡	Hologram ‡
Presto ‡	Pop	Entourage	In The Loop
Soliloquy	Radiance	Fable CR	Island
Sonnet	Ransom	Fibra	Masquerade
Stacks	Ricochet ‡	Greenwich	Menagerie
Trophy	Roam	Hudson	Origins
	Rush Hour	Hula Hoop ‡	Satellite ‡
	Prairie	Kaleidoscope CR	Satin Chisel ‡
B	Prim ‡	Kora CR	Tara
Abacus ‡	Soiree	Lagos	Theory
Argyle	Spark ‡	Legend CR	Woodland
Backdrop	Bank Shot	Lore CR	Zoom
Bank Shot	Belize	Metro	E
Betwixt ‡	Bistro ‡	Milestone	Ikat Square
Bistro ‡	Boundary ‡	Moto CR ‡	Ikat Stripe
Boundary ‡	Cameo	Noble	Kampala
Cameo	Chroma ‡	Palisade	Katazome
Chroma ‡	Chronicle	Panache CR	Kimono
Chronicle	Close Knit	Posh	Luberon
Close Knit	Digit ‡	Quark	Mamba
Digit ‡	Digital Tape	Regard CR	Marquee
Digital Tape	Dovetail ‡	Roundtrip	Meroe
Dovetail ‡	Fast Forward	Sequin CR	Sherman
Fast Forward	Ferry	Sahara	Shima
Ferry		Sandpiper	Tryst
		Sinclair	Whip

Spinneybeck Leather

U	X
Vicenza ‡	Ducale ‡
Volo ‡	Ducale Velour ‡
V	Y
Acqua ‡	Capri ‡
Andes ‡	Cervo
Embossed Tipped	Copenhagen ‡
España ‡	Cordovan ‡
Hand Tipped ‡	Distressed ‡
Maremma ‡	Lucca
Velluto Pelle ‡	Marissa ‡
	Portofino ‡
W	Prima ‡
Alaska ‡	Riva ‡
Amazon ‡	Saddle ‡
Antique ‡	Salon ‡
Arizona ‡	Torello
Derby ‡	
Forte ‡	
Lucente ‡	
Sabrina ‡	

‡ Approved for Cal 133 upholstery.

Check with your KnollTextiles or Spinneybeck Representative for changes or additions.

Joe and Linda Ricchio

JR[®] and Ricchio Chair with Upholstered Seat

	description	seat h	arm h	w	d	h	textile fabric yds.	req. leather sq. ft.	weight	finish
<i>Designer(s):</i> Joseph and Linda Ricchio, 1990	44A JR Arm chair, non-stacking 	19"	25 3/4"	23 1/2"	21 5/8"	32 1/8"	0.7	13	14 lbs.	maple, ebonized
		19"	25 3/4"	23 1/2"	21 5/8"	32 1/8"	0.7	13	14 lbs.	other finishes
<i>Award(s):</i> Roscoe, 1991										
	44R Seat basket replacement for 44A and 44A-U						0.8	14.5		



Order Code

<i>Example:</i>	37A-T-BN-K1320/4
37A	Arm chair
T	Thick seat
BN	Natural Beech
K1320/4	Cornaro, Tabasco

Specify:

1. Pattern number
2. Thick seat option (Ricchio chair only)
3. Finish selection
4. Cal 133 Fire Code option
5. Textile selection

Maple:

Clear Maple (suffix KC)

Beech frame stains:

Beech (suffix B311)
 Bronzed Cherry (suffix B312A)
 Burnt Walnut (suffix B313)
 Deep Red Mahogany (suffix B328)
 Ebonized (suffix BE)
 Light Cherry (suffix B315)
 Medium Cherry (suffix B319)
 Medium Red Mahogany (suffix BR)
 Medium Walnut (suffix B323)
 Natural Beech (suffix BN)
 Warm Brown Walnut (suffix J)

Ordering Information

Upholstery/COM information:

Prices shown include fabric or leather upholstery. Contact your Knoll representative for colors. Only approved KnollTextiles and Spinneybeck leathers may be ordered.

Customer's Own Material is available pending approval. For approval requirements, processing instructions and ordering information please see page 18.

KnollStudio wood finishes:

KnollStudio wood finishes complement a large variety of KnollStudio veneer and Knoll Office veneer finishes. To select correct complementary finish, please refer to KnollStudio Wood Finish Matrix on page 25. If no complementary standard finish is available, please refer to custom finish policy below.

Custom finishes:

Complementary finishes to any KnollStudio or Knoll Office wood finish are available at no upcharge. To complement non-Knoll wood veneer or lumber finishes, a one-time, non-negotiable net upcharge of \$618 applies. Re-orders are at no upcharge. Please contact your KnollStudio representative, dealer or Customer Service associate for complete custom finish information and Order Code. Minimum order quantity for any custom finish order: 4 chairs.

Cal 133 Fire Code #:

The JR and Ricchio Chairs comply with the California Technical Bulletin 133 standard if upholstered in Cal 133 approved upholstery. Specify suffix -C at end of pattern number and suffix -133 at end of textile selection. Upcharge applies, see page 19.

Certified Wood:

Chairs manufactured using FSC certified hardwoods are available through Custom Product Development. Extended leadtime and upcharge apply.

Maintenance:

See pages 28-29.

Note:

The JR and Ricchio Chair are Greenguard certified.

JR Chair (44A) does not stack.

Construction

Frame:

Select clear maple hardwood in clear or beech hardwood in stained finish. Dowel and mortise and tenon construction.

Upholstered seat:

Injection-molded copolymer plastic seat pan screws into corner blocks of chair frame. Standard seat basket is 1" thick. Thick seat basket option is 2" (Ricchio chair only). Note upcharge above.

Upholstered Seat:

High density, polyurethane foam used in all upholstered areas. Elastic seat belt suspension.

Seat Basket Replacement:

Upholstered seat sits on chair frame. Screws lock basket in place for easy installation or removal. For seat basket replacements for JR chairs ordered prior to February 2007, specify pattern numbers 37R-S. Pricing for 44R will apply.

Finish:

Catalyzed lacquer protective coating. Hand-applied final wax coating.

Glides:

Recessed plastic glides.

pattern no.	upcharge	grades										COL			
		A	B	C	D	E	F	G	H	I	U	V	W	X	Y
44A-(KC, BE)		\$1,250.	\$1,280.	\$1,301.	\$1,329.	\$1,354.	\$1,368.	\$1,399.	\$1,451.	\$1,487.	\$1,626.	\$1,719.	\$1,918.	\$1,957.	\$2,005.
44A-()		1,187.	1,215.	1,238.	1,265.	1,292.	1,302.	1,334.	1,387.	1,424.	1,563.	1,655.	1,853.	1,894.	1,941.
44R-()		225.	252.	276.	305.	327.	342.	374.	420.	464.	597.	692.	891.	932.	979.

Approved KnollTextiles Grades/Fabrics

A	B	C	C
Alignment ‡	Forza	Atlas	Smart
Analogy	Gala II	Autobahn ‡	Star Struck ‡
Beacon	Grande	Axiom	Stepping Stones
Bocce	Grandview	Baxter	Spectator
Cat's Cradle	Holbrook	Biota ‡	Swing
Chance	Journey	Cairo	Tight Rope
Common Ground ‡	Knoll Felt	Charm ‡	Tilden
Commuter Cloth ‡	Knoll Hopsack	Circa	Tower Grid
Cotton Duck ‡	Ludlow	Classic Boucle	Transition ‡
Dristi	Lyric ‡	Dahlia CR	Treble CR
Foil Rap	Keaton	Decade	Vibe
Heavy Metal	Mini Stitch ‡	Dune	Zari CR
Hourglass	Night Life	Durand	
Mariner	Nonchalant CR	Earthwork ‡	D
Metaphor	Odeon	Echo	Compass CR
Monarch ‡	Paradigm	Empire Stripe	Coterie
Prep ‡	Petal Pusher	Enmesh ‡	Eclat Weave
Presto ‡	Pop	Entourage	Hologram ‡
Soliloquy	Radiance	Fable CR	In The Loop
Sonnet	Ransom	Fibra	Island
Stacks	Ricochet ‡	Greenwich	Masquerade
Trophy	Roam	Hudson	Menagerie
	Rush Hour	Hula Hoop ‡	Origins
	Prairie	Kaleidoscope CR	Satellite ‡
E	Prim ‡	Kora CR	Satin Chisel ‡
Abacus ‡	Soiree	Lagos	Tara
Argyle	Spark ‡	Legend CR	Theory
Backdrop	Spinoff Nuance ‡	Lore CR	Woodland
Bank Shot	Spree	Metro	Zoom
Belize	Starry Night ‡	Milestone	
Betwixt ‡	Summit	Moto CR ‡	E
Bistro ‡	Sutton	Noble	Ikat Square
Boundary ‡	Synth	Palisade	Ikat Stripe
Cameo	Utmost	Panache CR	Kampala
Chroma ‡	Venue	Posh	Katazome
Chronicle	Versa	Quark	Kimono
Close Knit	Vinyl	Regard CR	Luberon
Digit ‡	Westwood	Roundtrip	Mamba
Digital Tape	Wide Angle ‡	Sequin CR	Marquee
Dovetail ‡	Zephyr	Sahara	Meroe
Fast Forward	Zipline	Sandpiper	Sherman
Ferry		Sinclair	Shima
			Tryst
			Whip

Spinneybeck Leather

U	X
Vicenza ‡	Ducale ‡
Volo ‡	Ducale Velour ‡
V	Y
Acqua ‡	Capri ‡
Andes ‡	Cervo
Embossed Tipped	Copenhagen ‡
España ‡	Cordovan ‡
Hand Tipped ‡	Distressed ‡
Maremma ‡	Lucca
Velluto Pelle ‡	Marissa ‡
	Portofino ‡
W	Prima ‡
Alaska ‡	Riva ‡
Amazon ‡	Saddle ‡
Antique ‡	Salon ‡
Arizona ‡	Torello
Derby ‡	
Forte ‡	
Lucente ‡	
Sabrina ‡	

‡ Approved for Cal 133 upholstery.

Check with your KnollTextiles or Spinneybeck Representative for changes or additions.

Joe and Linda Ricchio

Fully Upholstered Ricchio and JR® Chairs

	description	seat h	arm h	w	d	h	textile fabric yds.	req. leather sq. ft.	weight	finish
<i>Designer(s):</i> Joseph and Linda Ricchio, 1994	37A-U Ricchio arm chair, uphol. seat and back 	18 1/2"	26"	21 3/8"	23 3/4"	32 1/4"	1	19	21 lbs.	maple, ebonized
		18 1/2"	26"	21 3/8"	23 3/4"	32 1/4"	1	19	21 lbs.	other finishes



Order Code

<i>Example:</i>	37A-U-B319-K1084/2
37A	Ricchio arm chair, upholstered seat and back
U	Upholstered seat and back
B319	Medium Cherry
K1084/2	Harrison, Campbell

Specify:

1. Pattern number
2. Finish selection
3. Cal 133 Fire Code option
4. Textile selection

Maple:

Clear Maple (suffix KC)

Beech frame stains:

Beech (suffix B311)
 Bronzed Cherry (suffix B312A)
 Burnt Walnut (suffix B313)
 Deep Red Mahogany (suffix B328)
 Ebonized (suffix BE)
 Light Cherry (suffix B315)
 Medium Cherry (suffix B319)
 Medium Red Mahogany (suffix BR)
 Medium Walnut (suffix B323)
 Natural Beech (suffix BN)
 Warm Brown Walnut (suffix J)

Ordering Information

Upholstery/COM information:

Prices shown include fabric or leather upholstery. Contact your Knoll representative for colors. Only approved KnollTextiles and Spinneybeck leathers may be ordered.

Customer's Own Material is available pending approval. For approval requirements, processing instructions and ordering information please see page 18.

KnollStudio wood finishes:

KnollStudio wood finishes complement a large variety of KnollStudio veneer and Knoll Office veneer finishes. To select correct complementary finish, please refer to KnollStudio Wood Finish Matrix on page 25. If no complementary standard finish is available, please refer to custom finish policy below.

Custom finishes:

Complementary finishes to any KnollStudio or Knoll Office wood finish are available at no upcharge. To complement non-Knoll wood veneer or lumber finishes, a one-time, non-negotiable net upcharge of \$618 applies. Re-orders are at no upcharge. Please contact your KnollStudio representative, dealer or Customer Service associate for complete custom finish information and Order Code. Minimum order quantity for any custom finish order: 4 chairs.

Cal 133 Fire Code:

The Fully Upholstered Ricchio Chairs comply with the California Technical Bulletin 133 standard if upholstered in Cal 133 approved upholstery. Specify suffix -C at end of pattern number and suffix -133 at end of textile selection. Upcharge applies, see page 19.

Certified Wood:

Chairs manufactured using FSC certified hardwoods are available through Custom Product Development. Extended leadtime and upcharge apply.

Maintenance:

See pages 28-29

Note:

The Fully Upholstered Ricchio and JR Chairs are Greenguard certified.

Construction

Frame:

Select clear maple hardwood in clear or beech hardwood in stained finish.

Fully upholstered chairs:

Plywood core back panel bolted to frame for added strength. Optional arm panels have plywood core bolted to frame. Injection-molded plastic seat pan. High density, polyurethane foam used in all upholstered areas. JR fully upholstered chair does not stack.

Finish:

Catalyzed lacquer protective coating. Hand-applied final wax coating.

Glides:

Recessed plastic glides.

pattern no.	grades A	COM B	C	D	E	F	G	H	I	COL U	V	W	X	Y
37A-U-(KC, BE)	\$1,689.	\$1,726.	\$1,762.	\$1,798.	\$1,831.	\$1,854.	\$1,894.	\$1,964.	\$2,019.	\$2,376.	\$2,519.	\$2,797.	\$2,858.	\$2,925.
37A-U(-)	1,603.	1,642.	1,677.	1,713.	1,747.	1,770.	1,810.	1,880.	1,936.	2,294.	2,435.	2,714.	2,774.	2,841.

Approved KnollTextiles Grades/Fabrics

A	E continued	C	C continued
Alignment ‡	Fast Forward	Atlas	Regard CR
Analogy	Ferry	Autobahn ‡	Roundtrip
Beacon	Forza	Axiom	Sandpiper
Bocce	Gala II	Baxter	Sequin CR
Cat's Cradle	Grande	Biota ‡	Sinclair
Common Ground ‡	Grandview	Cairo	Smart
Commuter Cloth ‡	Holbrook	Chance	Star Struck
Cotton Duck ‡	Journey	Charm	Stepping Stones
Dristi	Keaton	Circa	Spectator
Foil Rap	Knoll Felt	Classic Boucle	Swing
Heavy Metal	Knoll Hopsack	Decade	Tight Rope
Hourglass	Lytic ‡	Durand	Tilden
Mariner	Mini Stitch ‡	Earthwork ‡	Tower Grid
Metaphor	Night Life	Echo	Transition ‡
Prep ‡	Nonchalant CR	Empire Stripe	Treble CR
Presto ‡	Paradigm	Enmesh ‡	Vibe
Soliloquy	Petal Pusher	Entourage	Zari CR
Sonnet	Pop	Fibra	
Stacks	Prairie	Greenwich	D
Trophy	Prim ‡	Hudson	Compass CR
	Radiance	Hula Hoop	Coterie
	Ransom	Kaleidoscope CR	Eclat Weave
B	Ricochet ‡	Kora CR	Hologram ‡
Abacus ‡	Roam	Lagos	In The Loop
Argyle	Rush Hour	Legend CR	Island
Backdrop	Soiree	Lore CR	Masquerade
Bank Shot	Spark ‡	Metro	Menagerie
Belize	Spinoff Nuance ‡	Milestone	Origins
Betwixt ‡	Spree	Moto CR ‡	Satellite ‡
Bistro ‡	Starry Night ‡	Noble	Satin Chisel
Boundary ‡	Summit	Palisade	Tara
Cameo	Sutton	Panache CR	Theory
Chroma ‡	Synth	Quark	Woodland
Chronicle	Utmost		Zoom
Close Knit	Venue		
Digit ‡	Versa		
Digital Tape	Vinyl		
	Westwood		
	Wide Angle ‡		
	Zephyr		
	Zipline		

Spinneybeck Leather

U	W continued
Vicenza ‡	Forte ‡
Volo ‡	Lucente
	Sabrina ‡
V	X
Acqua ‡	Ducale Velour ‡
Andes ‡	
Embossed Tipped	Y
España ‡	Capri ‡
Velluto Pelle ‡	Cervo
	Copenhagen ‡
W	Cordovan ‡
Alaska ‡	Distressed ‡
Amazon ‡	Marissa ‡
Antique ‡	Prima ‡
Arizona ‡	Riva ‡
	Torello

‡ Approved for Cal 133 upholstery.

Check with KnollTextiles or Spinneybeck Representative for changes or additions.

Joe and Linda Ricchio

Fully Upholstered Ricchio and JR® Chairs

	description	seat h	arm h	w	d	h	textile fabric yds.	req. leather sq. ft.	weight	finish
<i>Designer(s):</i> Joseph and Linda Ricchio, 1994	37C-U Ricchio armless chair, uphol. seat and back 	18 1/2"		21 3/8"	23 3/4"	32 1/4"	1	19	19 lbs.	maple, ebonized
		18 1/2"		21 3/8"	23 3/4"	32 1/4"	1	19	19 lbs.	other finishes



Order Code

<i>Example:</i>	37A-U-B319-K1084/2
37A	Ricchio arm chair, upholstered seat and back
U	Upholstered seat and back
B319	Medium Cherry
K1084/2	Harrison, Campbell

Specify:

1. Pattern number
2. Finish selection
3. Cal 133 Fire Code option
4. Textile selection

Maple:

Clear Maple (suffix KC)

Beech frame stains:

Beech (suffix B311)
 Bronzed Cherry (suffix B312A)
 Burnt Walnut (suffix B313)
 Deep Red Mahogany (suffix B328)
 Ebonized (suffix BE)
 Light Cherry (suffix B315)
 Medium Cherry (suffix B319)
 Medium Red Mahogany (suffix BR)
 Medium Walnut (suffix B323)
 Natural Beech (suffix BN)
 Warm Brown Walnut (suffix J)

Ordering Information

Upholstery/COM information:

Prices shown include fabric or leather upholstery. Contact your Knoll representative for colors. Only approved KnollTextiles and Spinneybeck leathers may be ordered.

Customer's Own Material is available pending approval. For approval requirements, processing instructions and ordering information please see page 18.

KnollStudio wood finishes:

KnollStudio wood finishes complement a large variety of KnollStudio veneer and Knoll Office veneer finishes. To select correct complementary finish, please refer to KnollStudio Wood Finish Matrix on page 25. If no complementary standard finish is available, please refer to custom finish policy below.

Custom finishes:

Complementary finishes to any KnollStudio or Knoll Office wood finish are available at no upcharge. To complement non-Knoll wood veneer or lumber finishes, a one-time, non-negotiable net upcharge of \$618 applies. Re-orders are at no upcharge. Please contact your KnollStudio representative, dealer or Customer Service associate for complete custom finish information and Order Code. Minimum order quantity for any custom finish order: 4 chairs.

Cal 133 Fire Code:

The Fully Upholstered Ricchio Chairs comply with the California Technical Bulletin 133 standard if upholstered in Cal 133 approved upholstery. Specify suffix -C at end of pattern number and suffix -133 at end of textile selection. Upcharge applies, see page 19.

Certified Wood:

Chairs manufactured using FSC certified hardwoods are available through Custom Product Development. Extended leadtime and upcharge apply.

Maintenance:

See pages 28-29

Note:

The Fully Upholstered Ricchio and JR Chairs are Greenguard certified.

Construction

Frame:

Select clear maple hardwood in clear or beech hardwood in stained finish.

Fully upholstered chairs:

Plywood core back panel bolted to frame for added strength. Optional arm panels have plywood core bolted to frame. Injection-molded plastic seat pan. High density, polyurethane foam used in all upholstered areas. JR fully upholstered chair does not stack.

Finish:

Catalyzed lacquer protective coating. Hand-applied final wax coating.

Glides:

Recessed plastic glides.

pattern no.	grades A	COM B	C	D	E	F	G	H	I	COL U	V	W	X	Y
37C-U-(KC, BE)	\$1,613.	\$1,650.	\$1,681.	\$1,720.	\$1,754.	\$1,776.	\$1,815.	\$1,888.	\$1,941.	\$2,300.	\$2,439.	\$2,720.	\$2,780.	\$2,846.
37C-U(-)	1,532.	1,568.	1,600.	1,640.	1,674.	1,695.	1,736.	1,809.	1,860.	2,220.	2,360.	2,640.	2,699.	2,767.

Approved KnollTextiles Grades/Fabrics

A	E continued	C	C continued
Alignment ‡	Fast Forward	Atlas	Regard CR
Analogy	Ferry	Autobahn ‡	Roundtrip
Beacon	Forza	Axiom	Sandpiper
Bocce	Gala II	Baxter	Sequin CR
Cat's Cradle	Grande	Biota ‡	Sinclair
Common Ground ‡	Grandview	Cairo	Smart
Commuter Cloth ‡	Holbrook	Chance	Star Struck
Cotton Duck ‡	Journey	Charm	Stepping Stones
Dristi	Keaton	Circa	Spectator
Foil Rap	Knoll Felt	Classic Boucle	Swing
Heavy Metal	Knoll Hopsack	Decade	Tight Rope
Hourglass	Lytic ‡	Durand	Tilden
Mariner	Mini Stitch ‡	Earthwork ‡	Tower Grid
Metaphor	Night Life	Echo	Transition ‡
Prep ‡	Nonchalant CR	Empire Stripe	Treble CR
Presto ‡	Paradigm	Enmesh ‡	Vibe
Soliloquy	Petal Pusher	Entourage	Zari CR
Sonnet	Pop	Fibra	
Stacks	Prairie	Greenwich	D
Trophy	Prim ‡	Hudson	Compass CR
	Radiance	Hula Hoop	Coterie
	Ransom	Kaleidoscope CR	Eclat Weave
B	Ricochet ‡	Kora CR	Hologram ‡
Abacus ‡	Roam	Lagos	In The Loop
Argyle	Rush Hour	Legend CR	Island
Backdrop	Soiree	Lore CR	Masquerade
Bank Shot	Spark ‡	Metro	Menagerie
Belize	Spinoff Nuance ‡	Milestone	Origins
Betwixt ‡	Spree	Moto CR ‡	Satellite ‡
Bistro ‡	Starry Night ‡	Noble	Satin Chisel
Boundary ‡	Summit	Palisade	Tara
Cameo	Sutton	Panache CR	Theory
Chroma ‡	Synth	Quark	Woodland
Chronicle	Utmost		Zoom
Close Knit	Venue		
Digit ‡	Versa		
Digital Tape	Vinyl		
	Westwood		
	Wide Angle ‡		
	Zephyr		
	Zipline		

Spinneybeck Leather

U	W continued
Vicenza ‡	Forte ‡
Volo ‡	Lucente
	Sabrina ‡
V	X
Acqua ‡	Ducale Velour ‡
Andes ‡	
Embossed Tipped	Y
España ‡	Capri ‡
Velluto Pelle ‡	Cervo
	Copenhagen ‡
W	Cordovan ‡
Alaska ‡	Distressed ‡
Amazon ‡	Marissa ‡
Antique ‡	Prima ‡
Arizona ‡	Riva ‡
	Torello

‡ Approved for Cal 133 upholstery.

Check with KnollTextiles or Spinneybeck Representative for changes or additions.

Joe and Linda Ricchio

Fully Upholstered Ricchio and JR® Chairs

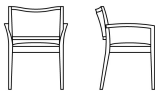
	description	seat h	arm h	w	d	h	textile fabric yds.	req. leather sq. ft.	weight	finish
<i>Designer(s):</i> Joseph and Linda Ricchio, 1994	44A-U JR Arm chair, uphol. seat and back 	19"	26"	24"	22"	32"	1	18	15 lbs.	maple, ebonized
		19"	26"	24"	22"	32"	1	18	15 lbs.	other finishes



Order Code

<i>Example:</i>	37A-U-B319-K1084/2
37A	Ricchio arm chair, upholstered seat and back
U	Upholstered seat and back
B319	Medium Cherry
K1084/2	Harrison, Campbell

Specify:

1. Pattern number
2. Finish selection
3. Cal 133 Fire Code option
4. Textile selection

Maple:

Clear Maple (suffix KC)

Beech frame stains:

Beech (suffix B311)
 Bronzed Cherry (suffix B312A)
 Burnt Walnut (suffix B313)
 Deep Red Mahogany (suffix B328)
 Ebonized (suffix BE)
 Light Cherry (suffix B315)
 Medium Cherry (suffix B319)
 Medium Red Mahogany (suffix BR)
 Medium Walnut (suffix B323)
 Natural Beech (suffix BN)
 Warm Brown Walnut (suffix J)

Ordering Information

Upholstery/COM information:

Prices shown include fabric or leather upholstery. Contact your Knoll representative for colors. Only approved KnollTextiles and Spinneybeck leathers may be ordered.

Customer's Own Material is available pending approval. For approval requirements, processing instructions and ordering information please see page 18.

KnollStudio wood finishes:

KnollStudio wood finishes complement a large variety of KnollStudio veneer and Knoll Office veneer finishes. To select correct complementary finish, please refer to KnollStudio Wood Finish Matrix on page 25. If no complementary standard finish is available, please refer to custom finish policy below.

Custom finishes:

Complementary finishes to any KnollStudio or Knoll Office wood finish are available at no upcharge. To complement non-Knoll wood veneer or lumber finishes, a one-time, non-negotiable net upcharge of \$618 applies. Re-orders are at no upcharge. Please contact your KnollStudio representative, dealer or Customer Service associate for complete custom finish information and Order Code. Minimum order quantity for any custom finish order: 4 chairs.

Cal 133 Fire Code:

The Fully Upholstered Ricchio Chairs comply with the California Technical Bulletin 133 standard if upholstered in Cal 133 approved upholstery. Specify suffix -C at end of pattern number and suffix -133 at end of textile selection. Upcharge applies, see page 19.

Certified Wood:

Chairs manufactured using FSC certified hardwoods are available through Custom Product Development. Extended leadtime and upcharge apply.

Maintenance:

See pages 28-29

Note:

The Fully Upholstered Ricchio and JR Chairs are Greenguard certified.

Construction

Frame:

Select clear maple hardwood in clear or beech hardwood in stained finish.

Fully upholstered chairs:

Plywood core back panel bolted to frame for added strength. Optional arm panels have plywood core bolted to frame. Injection-molded plastic seat pan. High density, polyurethane foam used in all upholstered areas. JR fully upholstered chair does not stack.

Finish:

Catalyzed lacquer protective coating. Hand-applied final wax coating.

Glides:

Recessed plastic glides.

pattern no.	grades A	COM B	C	D	E	F	G	H	I	COL U	V	W	X	Y
44AU-(KC, BE)	\$1,640.	\$1,668.	\$1,695.	\$1,727.	\$1,751.	\$1,769.	\$1,800.	\$1,858.	\$1,899.	\$2,035.	\$2,138.	\$2,349.	\$2,392.	\$2,445.
44AU-()	1,479.	1,508.	1,535.	1,565.	1,590.	1,606.	1,637.	1,695.	1,738.	1,872.	1,978.	2,188.	2,229.	2,282.

Approved KnollTextiles Grades/Fabrics

A	Alignment ‡	Analogy	Beacon	Bocce	Cat's Cradle	Common Ground ‡	Commuter Cloth ‡	Cotton Duck ‡	Dristi	Foil Rap	Heavy Metal	Hourglass	Mariner	Metaphor	Prep ‡	Presto ‡	Soliloquy	Sonnet	Stacks	Trophy													
B	Abacus ‡	Argyle	Backdrop	Bank Shot	Belize	Betwixt ‡	Bistro ‡	Boundary ‡	Cameo	Chroma ‡	Chronicle	Close Knit	Digit ‡	Digital Tape																			
C	Atlas	Autobahn ‡	Axiom	Baxter	Biota ‡	Cairo	Chance	Charm	Circa	Classic Boucle	Decade	Durand	Earthwork ‡	Echo	Empire Stripe	Enmesh ‡	Entourage	Fibra	Greenwich	Hudson	Hula Hoop	Kaleidoscope CR	Kora CR	Lagos	Legend CR	Lore CR	Metro	Milestone	Moto CR ‡	Noble	Palisade	Panache CR	Quark
C continued	Regard CR	Roundtrip	Sandpiper	Sequin CR	Sinclair	Smart	Star Struck	Stepping Stones	Spectator	Swing	Tight Rope	Tilden	Tower Grid	Transition ‡	Treble CR	Vibe	Zari CR																
D	Compass CR	Coterie	Eclat Weave	Hologram ‡	In The Loop	Island	Masquerade	Menagerie	Origins	Satellite ‡	Satin Chisel	Tara	Theory	Woodland	Zoom																		
E	Ikat Square	Ikat Stripe	Kampala	Katazome	Luberon	Mamba	Marquee	Meroe	Sherman	Shima	Tryst	Whip																					
F	Atelier	Biscayne	Calais Cotton	Velvet	Coco	Cornaro	Eclipse	Glider	Icon	Intrigue	Liberty	Mod Plaid	Rivington	Soon	Topography	Totem	Tweed Frieze																

Spinneybeck Leather

U	Vicenza ‡	Volo ‡							
V	Acqua ‡	Andes ‡	Embossed Tipped	España ‡	Velluto Pelle ‡				
W	Alaska ‡	Amazon ‡	Antique ‡	Arizona ‡					
W continued	Forte ‡	Lucente	Sabrina ‡						
X	Ducale Velour ‡								
Y	Capri ‡	Cervo	Copenhagen ‡	Cordovan ‡	Distressed ‡	Marissa ‡	Prima ‡	Riva ‡	Torello

‡ Approved for Cal 133 upholstery.



Check with KnollTextiles or Spinneybeck Representative for changes or additions.

Jens Risom

Side Chairs and Stool

Designer(s):
Jens Risom, 1943

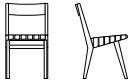

description	seat h	w	d	h	reuphol. kit ydg.	weight
666C-WB Side chair with webbed seat and back 	17 3/4"	17 1/4"	18"	30 3/8"		see below
666C-WB-KIT Re-upholstery kit for side chair with webbed back					14.0	
666C Side chair with webbed seat 	17 3/4"	17 1/4"	18"	30 3/8"		see below
666C-KIT Re-upholstery kit for side chair with wood back					9.0	
667Y Sitting stool 	17 1/8"	16 1/2"	15 1/8"	17 1/8"		see below
667Y-KIT Re-upholstery kit for stool					7.0	

Order Code

<i>Example:</i>	666C-WB-LWT-MZ
666C-WB	Risom side chair with webbed seat and back
LWT	Light Walnut
MZ	Maize cotton webbing

Note:
The Risom side chairs are part of a collection. Please refer to the Risom lounge chairs on page 240 and tables on page 370.

Specify:

1. Pattern number
2. Frame finish
3. Webbing color selection

Ordering Information

Frame finishes:
Clear Maple (suffix KC)
Ebonyed Maple (suffix KE)
Light Walnut (suffix LWT)

Cotton webbing colors:
Aubergine (suffix AU)
Black (suffix BL)
Dark Grey (suffix DG)
Flax (suffix FL)
Forest Green (suffix FG)
Khaki (suffix KH)
Maize (suffix MZ)
Navy (suffix NA)
Red (suffix RD)
Steel Blue (suffix SB)

Cotton/nylon webbing colors:
Blueberry (suffix BU)
Eucalyptus (suffix EU)
Licorice (suffix LC)
Nutmeg (suffix NM)
Squash (suffix SH)
Tomato (suffix TO)

Re-upholstery kit:
Webbing straps in one length to re-upholster existing chairs. Must be reupholstered by a professional upholsterer.

Note:
The Risom side chairs are Greenguard certified.

Maintenance:
See pages 28-29.

Construction

Frame:
Select maple or walnut hardwood with clear finish. Ebonyed finish is stained maple hardwood. Mortise and tenon construction.

Finish:
Catalyzed lacquer protective coating.

Upholstery:
Cotton webbing is 100% natural cotton. Nylon webbing straps are 60% nylon, 40% cotton with water repellent finish. Cotton and Nylon webbing are CAL133 approved.

pattern no.	maple, ebonized	walnut	webbing kit
666C-WB-(-)(-)	\$1,059.	\$1,321.	
666C-WB-KIT-(-)			117.
666C-(-)(-)	976.	1,267.	
666C-KIT-(-)			94.
667Y-(-)(-)	630.	660.	
667Y-KIT-(-)			81.

Weight:



Side chair with webbed seat and back in Maple and/or Ebonized finishes weigh 11 lbs, Walnut finish weigh 10 lbs. Side chair with webbed seat in Maple and/or Ebonized finishes weigh 10 lbs., Walnut finish weigh 9lbs. Sitting stool in Maple and/or Ebonized finishes weigh 7 lbs., Walnut finish weigh 6 lbs.

Jens Risom

Child's Side Chairs and Stool

Designer(s):
Jens Risom, 1943



description	seat h	w	d	h	reuphol. kit ydg.	weight
666CS Child's Risom chair, webbed seat only 	13 1/4"	13 1/8"	15 3/8"	23"		6 lbs.
666CS-KIT Re-upholstery kit for Child's side chair with webbed seat					7.0	
666CS-WB Child's Risom chair with webbed seat and back 	13 1/4"	13 1/8"	15 3/8"	23"		6 lbs.
666CS-WB-KIT Re-upholstery kit for Child's side chair with webbed seat and back					9.0	
667YS Child's sitting stool 	13 1/2"	12 3/8"	11 1/2"	13 1/2"		6 lbs.
667YS-KIT Re-upholstery kit for Child's Sitting stool					5.5	

Order Code

<i>Example:</i>	666CS-WB-HB-OR
666CS-WB	Child's Risom side chair with webbed seat and back
HB	Honey Beech
OR	Orange nylon webbing

Note:
The Child's Risom side chairs are part of a collection. Please refer to the Child's Risom Amoeba table on page 372.

Specify:

1. Pattern number
2. Frame finish
3. Webbing color selection

Ordering Information

Frame finishes:
Honey Beech (suffix HB)

Child's nylon webbing colors:
Blue (suffix BC)
Green (suffix GC)
Orange (suffix OC)
Red (suffix RC)

Re-upholstery kit:
Webbing straps in one length to re-upholster existing chairs. Must be reupholstered by a professional upholsterer.

Maintenance:
See pages 28-29.

Construction

Frame:
Select European Beech hardwood with a toned natural finish. Mortise and tenon construction.

Finish:
Toned catalyzed lacquer finish



Child's Risom Chairs:
Child's Risom Chairs are 75% scale of standard risom chair. Child's size chairs are only available in Honey Beech (HB) finish and approved nylon webbing.

Upholstery:
Nylon webbing straps are 60% nylon, 40% cotton with water repellent finish. Cotton and Nylon webbing are CAL133 approved.

Note:
The Child's Risom chair and stool are compliant to the Consumer Product Safety Improvement Act of 2008 for Children's Products, 16 C.F.R. 1303, CPSIA Title 1 Section 101 for Total Lead in Substrates and Surface Coatings.

pattern no.	honey beech	webbing kit
666CS-HB-()	\$357.	
666CS-KIT-()		68.
666CS-WB-HB-()	398.	
666CS-WB-KIT-()		99.
667YS-HB-()	259.	
667YS-KIT-()		60.

Jens Risom Lounge Chairs

	description	seat h	arm h	w	d	h	reuphol. kit ydg.	weight
<p><i>Designer(s):</i> Jens Risom, 1943</p> 	<p>654LA Arm lounge chair</p> 	16"	22"	23 3/4"	27 3/4"	30 1/4"		see below
	<p>654LC Armless lounge chair</p> 	16"		20"	27 1/2"	30 1/4"		see below
	<p>654L-KIT Re-upholstery kit for arm and armless lounge chair</p>						25	

Order Code

<i>Example:</i>	654LC-KC-RD
654LC	Risom lounge chair, armless
KC	Clear Maple
RD	Red cotton webbing

Note:
The Risom lounge chairs are part of a collection. Please refer to the Risom side chairs on page 236 and tables on page 370.

Specify:

1. Pattern number
2. Frame finish
3. Webbing color selection

Ordering Information

Frame finishes:
Clear maple (suffix KC)
Ebonized maple (suffix KE)
Light walnut (suffix LWT)

Cotton webbing colors:
Aubergine (suffix AU)
Black (suffix BL)
Dark grey (suffix DG)
Flax (suffix FL)
Forest green (suffix FG)
Khaki (suffix KH)
Maize (suffix MZ)
Navy (suffix NA)
Red (suffix RD)
Steel blue (suffix SB)

Cotton/nylon webbing colors:
Blueberry (suffix BU)
Eucalyptus (suffix EU)
Licorice (suffix LC)
Nutmeg (suffix NM)
Squash (suffix SH)
Tomato (suffix TO)

Re-upholstery kit:
Webbing straps in one length to re-upholster existing chairs. Must be reupholstered by a professional upholsterer.

Note:
The Risom Lounge chairs are Greenguard certified.

Maintenance:
See pages 28-29.

Construction

Frame:
Select maple or walnut hardwood with clear finish. Ebonized finish is stained maple hardwood. Mortise and tenon construction. Seat basket of arm lounge chair attaches to arm frame with invisible screws.

Finish:
Lacquer finish.

Upholstery:
Cotton webbing is 100% natural cotton. Nylon webbing straps are 60% nylon, 40% cotton with water repellent finish. Cotton and Nylon webbing are CAL133 approved.



pattern no.	maple, ebonized	walnut	webbing kit
654LA-(-)(-)	\$1,923.	\$2,019.	
654LC-(-)(-)	1,464.	1,537.	
654L-KIT-(-)			158.

Weight:

Arm lounge chair in Maple and/or Ebonized finishes weigh 20 lbs, Walnut finish weigh 17 lbs. Armless lounge chair in Maple and/or Ebonized finishes weigh 14 lbs., Walnut finish weigh 12 lbs.

Eero Saarinen

Tulip Chairs

description	upholstery	seat h	arm h	w	d	h	textile	req.	weight	
							fabric	leather		
							yds.	sq. ft.		
<i>Designer(s):</i> Eero Saarinen, 1957	150A Tulip arm chair 	inner shell	18"	25 7/8"	26"	23 1/4"	32"	2.3	n/a	24 lbs.
		seat cushion	18"	25 7/8"	26"	23 1/4"	32"	0.8	14	18 lbs.
	150K Upholstered cushion replacement, arm chair	inner shell	18"	25 7/8"	26"	23 1/4"	32"	2.3	n/a	23 lbs.
		seat cushion	18"	25 7/8"	26"	23 1/4"	32"	0.8	14	18 lbs.
<i>Award(s):</i> The Museum of Modern Art, New York, USA, 1969; Federal Award for Industrial Design, W. Germany, 1969; Design Center Stuttgart Award, W. Germany, 1962	151C Tulip armless chair 	inner shell	18 1/2"	20"	21 1/4"	32"	1.7	n/a	20 lbs.	
		seat cushion	18 1/2"	20"	21 1/4"	32"	0.8	14	17 lbs.	
		inner shell	18 1/2"	20"	21 1/4"	32"	1.7	n/a	19 lbs.	
		seat cushion	18 1/2"	20"	21 1/4"	32"	0.8	14	16 lbs.	
151K Upholstered cushion replacement, armless chair	seat cushion						0.8	14		
153Y Stool 		16 1/2"		15 1/2"		18"	0.8	14	10 lbs.	



Order Code

<i>Example:</i>	150AX-2-U-K451/4
150AX	Tulip arm chair, fixed position
2	White
U	Upholstered inner shell and seat cushion
K451/4	Una, Ebony

Note:
The Saarinen chairs are part of a collection. Please refer to Saarinen lounge seating, executive chairs and tables on pages 244 and 374.

Specify:

1. Pattern number
2. Swivel or fixed position
3. Finish selection
4. Upholstery option (except stool)
5. Textile selection

Ordering Information

Swivel or fixed position:
Swivel action (suffix S)
Fixed position (suffix X)

Base and shell finishes:
Black (suffix 1)
Platinum (suffix PL) (not on fully upholstered chairs)
White (suffix 2)

Upholstery options:
Upholstered seat cushion only (suffix K)
Upholstered inner shell and seat cushion (suffix U)

Upholstery/COM information:
Prices shown include fabric or leather upholstery. Contact your Knoll representative for colors. Only approved KnollTextiles and Spinneybeck leathers may be ordered.

Customer's Own Material is available pending approval. For approval requirements, processing instructions and ordering information please see page 18.

Maintenance:
See pages 28-29.

Note:
The signature of Eero Saarinen and the KnollStudio logo are located on the underside of the base.

The Tulip Chair is Greenguard certified.

Construction

Base:
Cast aluminum. Rilsan coated finish for black and white chairs, platinum polyurethane enamel wet coat with a clear satin finish.

Shell:
Molded fiberglass reinforced plastic bonded finish.

Upholstery:
Upholstered or unupholstered inner shell, with removable foam cushion (zippered cover and Velcro fastening).

Cal 133 Fire Code:
The 513Y Saarinen Stool complies with the California Technical Bulletin 133 standard if upholstered in Cal 133 approved upholstery. Specify suffix -C at end of pattern number and suffix -133 at end of textile selection. Upcharge applies, see page 19.

pattern no.	grades A	COM B	C	D	E	F	G	H	I	COL U	V	W	X	Y
150AS-(1,2)U	\$4,500.	\$4,575.	\$4,644.	\$4,725.	\$4,786.	\$4,835.	\$4,913.	\$5,060.	\$5,169.					
150AS-(1,2,PL)K	2,683.	2,706.	2,725.	2,749.	2,768.	2,780.	2,805.	2,848.	2,879.	2,973.	3,051.	3,207.	3,239.	3,275.
150AX-(1,2)U	4,203.	4,279.	4,349.	4,428.	4,492.	4,538.	4,616.	4,766.	4,877.					
150AX-(1,2,PL)K	2,530.	2,549.	2,572.	2,596.	2,613.	2,625.	2,650.	2,693.	2,725.	2,819.	2,896.	3,052.	3,083.	3,122.
150K	530.	553.	572.	595.	611.	624.	646.	687.	717.	876.	948.	1,095.	1,125.	1,160.
151CS-(1,2)U	3,795.	3,851.	3,902.	3,960.	4,008.	4,043.	4,099.	4,210.	4,290.					
151CS-(1,2,PL)K	2,312.	2,336.	2,357.	2,379.	2,398.	2,412.	2,435.	2,478.	2,510.	2,644.	2,722.	2,877.	2,909.	2,948.
151CX-(1,2)U	3,664.	3,718.	3,773.	3,830.	3,877.	3,910.	3,969.	4,080.	4,162.					
151CX-(1,2,PL)K	2,091.	2,115.	2,133.	2,157.	2,176.	2,189.	2,212.	2,256.	2,288.	2,521.	2,600.	2,754.	2,788.	2,824.
151K	530.	553.	572.	595.	611.	624.	646.	687.	717.	876.	948.	1,095.	1,125.	1,160.
153YS-(1, 2, PL)	1,367.	1,387.	1,407.	1,429.	1,446.	1,457.	1,481.	1,522.	1,553.	1,642.	1,712.	1,860.	1,891.	1,926.

Approved KnollTextiles Grades/Fabrics

A	Alignment *	Analogy	Beacon	Bocce *	Cat's Cradle *	Common Ground *	Commuter Cloth *▲	Delite *	Dristi *	Hourglass	Mariner *	Metaphor	Monarch	Prep	Presto (n/a on stool)	Soliloquy *	Sonnet *	Stacks *	Trophy *																				
B	Abacus *	Bank Shot *	Belize *	Betwixt *	Bistro *	Boundary *▲	Cameo *	Chroma	Chronicle	Close Knit *	Digit	Dovetail *	Ferry *	Gala II	Grande *																								
C	Atlas *	Autobahn	Axiom *	Baxter *	Biota *	Cairo *	Chance *	Charm *	Circa *	Classic Boucle *	Dahlia *	Dune	Durand *	Earthwork *	Echo *	Empire Stripe	Enmesh *	Entourage *	Fable CR *	Fibra *	Greenwich *	Hudson	Hula Hoop *	Kora CR	Lagos *	Legend CR	Lore CR	Magnolia	Metro	Milestone *	Moto CR *	Noble *	Panache CR *	Posh	Quark *	Regard CR *			
D	Roundtrip *	Sahara *	Sandpiper	Sequin CR *	Sinclair *	Smart *	Spectator *	Spot On *	Star Struck *	Stepping Stones	Swing *	Tight Rope *	Tilden *	Tower Grid *	Transition *	Treble CR *	Vibe *	Zari CR *																					
E	Highland *	Ikat Square *	Ikat Stripe *	Kampala *	Katazome *	Luberon *	Mamba *	Marquee *	Meroe *	Sherman *	Shima *	Whip *																											
F	Atelier *	Biscayne *	Calais Cotton Velvet	Century *	Coco *	Cornaro *	Eclipse *	Glider *	Icon *	Intrigue *	Liberty *	Mod Plaid *	Rivington *	Soon	Topography *	Totem *	Tweed Frieze *																						
G	Arabella *	Arber *	Djenne	Gibson *	Hampshire *	Haze *																																	

Spinneybeck Leather

U	Vicenza	Volo									
V	Acqua	Andes	Embossed Tipped	España	Hand Tipped	Velluto Pelle					
W	Alaska	Amazon	Antique	Arizona	Derby	Forté	Lucente	Sabrina			
X	Ducale	Ducale Velour									
Y	Capri	Cervo	Copenhagen	Cordovan	Distressed	Lucca	Marissa	Portofino	Prima	Riva	Torrello

* Approved for fully upholstered versions.

▲ Approved for Cal133 upholstery.

Check with your KnollTextiles or Spinneybeck Representative for changes or additions.

Eero Saarinen

Executive Arm Chairs

Designer(s): Eero Saarinen, 1950	description	seat h,	seat h,	w	d	h, min	h, max	textile	req.	weight	type
		min	max					fabric	leather		
	71A-T5G-H Executive arm chair with pneumatic seat height adjustment	16 1/2"	21 3/4"	26"	24 3/4"	31"	36 1/4"	2.9	47	34 lbs.	
	Executive arm chair with pneumatic seat height adjustment, contrast leather welt option	16 1/2"	21 3/4"	26"	24 3/4"	31"	36 1/4"	2.9	47	34 lbs.	uphol.
									6.25		welt
	71A Executive arm chair with tubular legs and glides	18"		26"	24 3/4"	31 1/2"		2.9	47	19 lbs.	
	Executive arm chair with tubular legs and glides, contrast leather welt option	18"		26"	24 3/4"	31 1/2"		2.9	47	19 lbs.	uphol.
									6.25		welt
	R Optional soft wheel casters (change -H to -R)										
	3 Optional black top caps (add -3 after 71A, not available for 71A-PC)										



Order Code

Example: **71A-3-T5G-R-ES8080**

71A	Open back arm chair
3	Black top caps
T5G	Advanced height adjustment, swivel/tilt
R	Soft wheel casters
ES8080	Espana, Serpentina

Note:

The Saarinen executive chairs are part of a collection. Please refer to Saarinen side chairs, lounge chairs and tables on beginning on pages 242 and 374.

Specify:

1. Pattern number
2. Black top cap option (swivel base only)
3. Caster type (swivel base only)
4. Cal 133 fire code option
5. Split upholstery option (add S)
6. Textile selection

Ordering Information

Wood Leg Finishes:

Ebonized Walnut (suffix D)
Light Oak (suffix LO)
Light Walnut (suffix LWA)
Pearwood (suffix P)
Polished Chrome (suffix C)
Reff Dark Cherry (suffix V314)

Tubular Leg Finishes:

Black (BL)
Polished Chrome (suffix C)

Caster option:

Hard wheel casters standard. For soft wheel casters, change -H in pattern number to -R. No glide option on swivel models.

Split upholstery option:

The seat and back of the Saarinen Executive Chair can be specified in split upholstery. Indicate S before selected seat upholstery, followed by selected back upholstery. The price equals the price of the higher upholstery grade.

COM split fabric requirements:

Back upholstery: 2.25 yards
Seat upholstery: 1.25 yards

COL split leather requirements:

Back upholstery: 40 square feet
Seat upholstery: 23 square feet

Upholstery/COM information:

Prices shown include fabric or leather upholstery. Contact your Knoll representative for colors. Only approved Knoll Textiles and Spinneybeck leathers may be ordered.

Customer's Own Material is available pending approval. For approval requirements, processing instructions and ordering information please see page 18.

Cal 133 Fire Code #:

The Saarinen Executive Chairs comply with the California Technical Bulletin 133 standard if upholstered in Cal 133 approved upholstery. Specify suffix -C at end of pattern number and suffix -133 at end of textile selection. Upcharge applies, see page 19.

Maintenance:

See pages 28-29.

Note:

The Saarinen Executive Arm Chair is Greenguard certified.

Construction

Frame:

Molded reinforced polyurethane shell.
Contoured plywood seat form.

Upholstery:

Urethane foam cushion. Welt detail along arm, back and top of seat is available as a self welt (same material) or as a contrasting leather welt. Please specify pattern number with LT suffix, for contrasting welt, and add appropriate leather upcharge for total list price of the piece. Leather welt option is available on both textile and leather upholstery.

Swivel base:

Five-star steel base in protective black epoxy finish. Stainless steel or optional black epoxy top caps.

Steel leg base:

Four legs in seamless tubular steel with polished chrome or matte black powder coat.

pattern no.	upcharge	grades A	COM B	C	D	E	F	G	H	I	COL U	V	W	X	Y
71A-T5G-(-)(-)		\$2,976.	\$3,054.	\$3,130.	\$3,215.	\$3,283.	\$3,332.	\$3,417.	\$3,575.	\$3,694.	\$4,645.	\$4,905.	\$5,427.	\$5,537.	\$5,662.
71A-T5G-(-)-LT-(-)(-)		2,976.	3,054.	3,130.	3,215.	3,283.	3,332.	3,417.	3,575.	3,694.	4,645.	4,905.	5,427.	5,537.	5,662.
upchg, welt											227.	258.	321.	334.	350.
71A-(BL,C)-(-)		2,196.	2,274.	2,353.	2,435.	2,504.	2,552.	2,638.	2,795.	2,914.	3,863.	4,119.	4,642.	4,750.	4,879.
71A-(BL,C)-LT-(-)(-)		2,196.	2,274.	2,353.	2,435.	2,504.	2,552.	2,638.	2,795.	2,914.	3,863.	4,119.	4,642.	4,750.	4,879.
upchg, welt											227.	258.	321.	334.	350.
R	n/c														
3	90.														

Approved KnollTextiles Grades/Fabrics

Spinneybeck Leather

Wood leg base:

Solid steam bent oak with a clear or stained finish. Finish is complementary match to Saarinen, Florence Knoll and Platner low tables.

Casters:

2" twin wheel hard casters for use on carpeted floors. Wheel and housing components in black textured plastic. Optional soft casters for use on wood and other resilient flooring (black with grey housing).

Glides:

Molded nylon disk in stamped steel shroud.

- A** Beacon
Common Ground ‡
Commuter Cloth ‡
Delite
Dristi
Hourglass
Mariner
Presto
Sonnet
Stacks
Trophy
- B** Abacus
Bank Shot
Boundary
Cameo
Digit
Ferry
Grande
Journey
Keaton
Knoll Felt ‡
Knoll Hopsack ‡
Lyric
Night Life
Petal Pusher
Pop
Prairie
Ricochet
Rush Hour
Spinoff Nuance
Starry Night
- C** Axiom
Classic Boucle
Durand
Echo
Entourage
Hula Hoop
Lagos
Metro
Palisade
Quark
Sequin CR
Sinclair
Smart
Stepping Stones
Swing
Tilden
Transition
- D** continued
Sutton
Synth
Venue
Vinyl
Westwood
Wide Angle
Zephyr
- E** continued
Satellite
Satin Chisel
Tara
Theory
Woodland
Zoom
- F** Highland
Kampala
Luberon
Mamba
Sherman
- G** Arber
Hampshire
Haze
Kinabalu
Melange
Metallic Gloss
Sablon
Serendipity
Ultrasuede
Utrillo
- H** Arno
Bavaria
Gezelle
Magritte
Rosemond
- I** Aswan
Cato
Diamond Days
Dynamic
Ita
Knoll Velvet
North Island
Rutledge
Tudor
Vermeer
Walker
Zimba

- U** Vicenza ‡
Volo ‡
- V** Acqua ‡
Andes ‡
España ‡
Velluto Pelle ‡
- W** Alaska ‡
Amazon ‡
Antique ‡
Arizona ‡
Derby ‡
Forte ‡
Lucente ‡
Sabrina ‡
- X** Ducale ‡
Ducale Velour ‡
- Y** Capri ‡
Cervo ‡
Copenhagen ‡
Cordovan ‡
Distressed ‡
Marissa ‡
Prima ‡
Riva ‡

‡ Approved for Cal 133 upholstery.

Check with your KnollTextiles or Spinneybeck Representative for changes or additions.

Eero Saarinen

Executive Arm Chairs

description	seat h,	seat h,	w	d	h, min	h, max	textile	req.	weight	type
	min	max					fabric	leather		
71A-W Executive arm chair with wood legs and glides 	18"	26"	24 3/4"	31 1/2"	2.9	47	18 lbs.			
Executive arm chair with wood legs and glides, contrast leather welt option	18"	26"	24 3/4"	31 1/2"	2.9	47	18 lbs.	uphol.		
							6.25		welt	

Designer(s):
Eero Saarinen, 1950



Order Code

Example: **71A-3-T5G-R-ES8080**

71A	Open back arm chair
3	Black top caps
T5G	Advanced height adjustment, swivel/tilt
R	Soft wheel casters
ES8080	Espana, Serpentina

Note:

The Saarinen executive chairs are part of a collection. Please refer to Saarinen side chairs, lounge chairs and tables on beginning on pages 242 and 374.

Specify:

1. Pattern number
2. Black top cap option (swivel base only)
3. Caster type (swivel base only)
4. Cal 133 fire code option
5. Split upholstery option (add S)
6. Textile selection

Ordering Information

Wood Leg Finishes:

Ebonized Walnut (suffix D)
Light Oak (suffix LO)
Light Walnut (suffix LWA)
Pearwood (suffix P)
Polished Chrome (suffix C)
Reff Dark Cherry (suffix V314)

Tubular Leg Finishes:

Black (BL)
Polished Chrome (suffix C)

Caster option:

Hard wheel casters standard. For soft wheel casters, change -H in pattern number to -R. No glide option on swivel models.

Split upholstery option:

The seat and back of the Saarinen Executive Chair can be specified in split upholstery. Indicate S before selected seat upholstery, followed by selected back upholstery. The price equals the price of the higher upholstery grade.

COM split fabric requirements:

Back upholstery: 2.25 yards
Seat upholstery: 1.25 yards

COL split leather requirements:

Back upholstery: 40 square feet
Seat upholstery: 23 square feet

Upholstery/COM information:

Prices shown include fabric or leather upholstery. Contact your Knoll representative for colors. Only approved Knoll Textiles and Spinneybeck leathers may be ordered.

Customer's Own Material is available pending approval. For approval requirements, processing instructions and ordering information please see page 18.

Cal 133 Fire Code #:

The Saarinen Executive Chairs comply with the California Technical Bulletin 133 standard if upholstered in Cal 133 approved upholstery. Specify suffix -C at end of pattern number and suffix -133 at end of textile selection. Upcharge applies, see page 19.

Maintenance:

See pages 28-29.

Note:

The Saarinen Executive Arm Chair is Greenguard certified.

Construction

Frame:

Molded reinforced polyurethane shell.
Contoured plywood seat form.

Upholstery:

Urethane foam cushion. Welt detail along arm, back and top of seat is available as a self welt (same material) or as a contrasting leather welt. Please specify pattern number with LT suffix, for contrasting welt, and add appropriate leather upcharge for total list price of the piece. Leather welt option is available on both textile and leather upholstery.

Swivel base:

Five-star steel base in protective black epoxy finish. Stainless steel or optional black epoxy top caps.

Steel leg base:

Four legs in seamless tubular steel with polished chrome or matte black powder coat.

pattern no.	upcharge	grades A	COM B	C	D	E	F	G	H	I	COL U	V	W	X	Y
71A-W-(-)(-)		\$2,571.	\$2,652.	\$2,730.	\$2,817.	\$2,888.	\$2,939.	\$3,026.	\$3,189.	\$3,311.	\$4,259.	\$4,528.	\$5,069.	\$5,180.	\$5,312.
71A-W-(-LT-(-)(-)		2,571.	2,652.	2,730.	2,817.	2,888.	2,939.	3,026.	3,189.	3,311.	4,259.	4,528.	5,069.	5,180.	5,312.
upchg, welt											227.	258.	321.	334.	350.

Approved KnollTextiles Grades/Fabrics

Wood leg base:
Solid steam bent oak with a clear or stained finish. Finish is complementary match to Saarinen, Florence Knoll and Platner low tables.

Casters:
2" twin wheel hard casters for use on carpeted floors. Wheel and housing components in black textured plastic. Optional soft casters for use on wood and other resilient flooring (black with grey housing).

Glides:
Molded nylon disk in stamped steel shroud.

- A** Beacon
Common Ground ‡
Commuter Cloth ‡
Delite
Dristi
Hourglass
Mariner
Presto
Sonnet
Stacks
Trophy
- B** Abacus
Bank Shot
Boundary
Cameo
Digit
Ferry
Grande
Journey
Keaton
Knoll Felt ‡
Knoll Hopsack ‡
Lyric
Night Life
Petal Pusher
Pop
Prairie
Ricochet
Rush Hour
Spinoff Nuance
Starry Night
- C** Axiom
Classic Boucle
Durand
Echo
Entourage
Hula Hoop
Lagos
Metro
Palisade
Quark
Sequin CR
Sinclair
Smart
Stepping Stones
Swing
Tilden
Transition
- D** continued
Sutton
Synth
Venue
Vinyl
Westwood
Wide Angle
Zephyr
- E** continued
Highland
Kampala
Luberon
Mamba
Sherman
- F** Atelier
Biscayne
Coco
Cornaro
Eclipse
Intrigue
Liberty
Rivington
Tweed Frieze
- D** continued
Satellite
Satin Chisel
Tara
Theory
Woodland
Zoom
- E** continued
Satellite
Satin Chisel
Tara
Theory
Woodland
Zoom
- G** Arber
Hampshire
Haze
Kinabalu
Melange
Metallic Gloss
Sablon
Serendipity
Ultrasuede
Utrillo
- H** Arno
Bavaria
Gezelle
Magritte
Rosemond
- I** Aswan
Cato
Diamond Days
Dynamic
Ita
Knoll Velvet
North Island
Rutledge
Tudor
Vermeer
Walker
Zimba

Spinneybeck Leather





- U** Vicenza ‡
Volo ‡
- V** Acqua ‡
Andes ‡
Embossed Tipped ‡
España ‡
Velluto Pelle ‡
- W** Alaska ‡
Amazon ‡
Antique ‡
Arizona ‡
Derby ‡
Forte ‡
Lucente ‡
Sabrina ‡
- X** Ducale ‡
Ducale Velour ‡
- Y** Capri ‡
Cervo ‡
Copenhagen ‡
Cordovan ‡
Distressed ‡
Marissa ‡
Prima ‡
Riva ‡

‡ Approved for Cal 133 upholstery.

Check with your KnollTextiles or Spinneybeck Representative for changes or additions.

Eero Saarinen

Executive Armless Chairs

	description	seat h, min	seat h, max	w	d	h, min	h, max	textile fabric yds.	req. leather sq. ft.	weight
<i>Designer(s):</i> Eero Saarinen, 1946	72C-T5G-H Executive armless chair with pneumatic seat height adjustment	14 1/2"	19 3/4"	22 1/2"	24"	31"	36 1/4"	2.0	35	29 lbs.
										
	72C Executive armless chair with tubular legs and glides	18 3/4"		22 1/2"	20 1/2"	31 1/2"		2.0	35	14 lbs.
										
	3 Optional black top caps (add -3 after 72C, not available for 72C-PC)									
	R Optional soft wheel casters (change -H to -R)									

Order Code

<i>Example:</i>	72C-C-S-CD70-AL5008
72C	Open back chair, armless
C	Polished chrome leg
S	Split upholstery option
CD70	seat: Cordovan, Rembrandt Brown
AL5008	back: Alaska, Caribou

Note:
The Saarinen executive chairs are part of a collection. Please refer to Saarinen side chairs, lounge chairs and tables on beginning on pages 242 and 374.

Specify:

1. Pattern number
2. Leg base option
3. Cal 133 fire code option
4. Split upholstery option (add S)
5. Textile selection, seat
6. Textile selection, back

Wood Leg Finishes:

Ebonized Walnut (suffix D)
Light Oak (suffix LO)
Light Walnut (suffix LWA)
Pearwood (suffix P)
Polished Chrome (suffix C)
Reff Dark Cherry (suffix V314)

Tubular Leg Finishes:

Black (suffix BL)
Polished Chrome (C)

Plastic Back Finishes:

Black (suffix 1)
White (suffix 2)

Ordering Information

Caster option:

Hard wheel casters standard. For soft wheel casters, change -H to -R. No glide option on swivel models.

Split upholstery option:

The seat and back of the Saarinen Executive Chair can be specified in split upholstery. Indicate S before selected seat upholstery, followed by selected back upholstery. The price equals the price of the higher upholstery grade.

COM split fabric requirements:

Back upholstery: 1.5 yards
Seat upholstery: .75 yards

COL split leather requirements:

Back upholstery: 27 square feet
Seat upholstery: 13.5 square feet

Upholstery/COM information:

Prices shown include fabric or leather upholstery. Contact your Knoll representative for colors. Only approved Knoll Textiles and Spinneybeck leathers may be ordered. Customer's Own Material is available pending approval. For approval requirements, processing instructions and ordering information please see page 18.

Cal 133 Fire Code:

The Saarinen Executive Chairs comply with the California Technical Bulletin 133 standard if upholstered in Cal 133 approved upholstery. Specify suffix -C at end of pattern number and suffix -133 at end of textile selection. Upcharge applies, see page 19.

Maintenance:

See pages 28-29.

Note:

The Saarinen Executive Armless Chair is Greenguard certified

Construction:

Frame:

Molded reinforced polyurethane shell. Contoured plywood seat form.

Plastic Back:

Polycarbonate with a wet coat paint in black or white. Note that the seat of the plastic back version is slightly wider than the fully upholstered version.

Upholstery:

Urethane foam cushion.

Swivel base:

Five-star steel base in protective black epoxy finish. Stainless steel or optional black epoxy top caps.

Steel Leg base:

Four legs in seamless tubular steel with polished chrome or matte black powder coat.

Wood leg base:

Solid steam bent oak with a clear or stained finish. Finish is complementary match to Saarinen, Florence Knoll and Platner low tables

Casters:

2" twin wheel hard casters for use on carpeted floors. Wheel and housing components in black textured plastic. Optional soft casters for use on wood and other resilient flooring (black with grey housing).

Glides:

Molded nylon disk in stamped steel shroud.

pattern no.	upcharge	grades A	COM B	C	D	E	F	G	H	I	COL U	V	W	X	Y
72C-T5G-H(-)		\$2,131.	\$2,187.	\$2,239.	\$2,297.	\$2,342.	\$2,377.	\$2,435.	\$2,545.	\$2,625.	\$3,137.	\$3,329.	\$3,717.	\$3,799.	\$3,893.
72C-(BL,C)-(-)		1,472.	1,526.	1,579.	1,636.	1,683.	1,718.	1,775.	1,885.	1,967.	2,447.	2,639.	3,027.	3,108.	3,203.
3	90.														
R	n/c														

Approved KnollTextiles Grades/Fabrics

A Beacon Bocce Cat's Cradle Chance Common Ground ♣ Commuter Cloth ♣ Delite Dristi Hourglass Mariner Prep ♣ Presto ♣ Soliloquy Sonnet Stacks Trophy	B Abacus ♣ Argyle Bank Shot ♣ Belize Betwixt Bistro ♣ Boundary Cameo Chroma Chronicle Digit Ferry Forza Gala II Grande Grandview Holbrook Journey Keaton Knoll Felt ♣ Knoll Hopsack ♣ Ludlow Lyric	B continued Mini Stitch ♣ Night Life Paradigm Petal Pusher Pop Prairie Prim ♣ Ransom Radiance Ricochet Roam Rush Hour Soiree Spark ♣ Spinoff Nuance Spree Starry Night ♣ Summit Sutton Synth Tabloid Venue Versa Vinyl Westwood Wide Angle ♣ Zephyr Zipline	C continued Empire Stripe Enmesh ♣ Entourage Fable CR Fibra Greenwich Hudson Hula Hoop Kaleidoscope CR Kora CR Lagos Lore CR Magnolia Metro Milestone Noble Palisade Panache CR Quark Regard CR Rountrip Sandpiper Sequin CR Sinclair Smart Spectator Spot On Star Struck ♣ Stepping Stones Swing Tilden Tower Grid Transition ♣ Treble CR Vibe Zari CR	D Compass CR Coterie Eclat Weave Hologram Island Masquerade Menagerie Origins Satellite Satin Chisel Tara Theory Woodland Zoom	E Highland Ikat Square Ikat Stripe Kampala Katazome Luberon Mamba Marquee Sherman Shima Tryst Whip
---	--	--	--	---	---

Spinneybeck Leather





F Atelier Biscayne Coco Cornaro Eclipse Glider Icon Intrigue Liberty Mod Plaid Rivington Soon Topography Totem Tweed Frieze	H Arno Bavaria Constance Gezelle Magritte Rosemond	I Aswan Canaan Cato Diamond Days Dynamic Gates Ita Jaipur Knoll Velvet North Island Olema Piper Rutledge Tudor Vermeer Walker Worth Zimba	U Vicenza ♣ Volo ♣	V Acqua ♣ Andes ♣ Embossed Tipped ♣ España ♣ Velluto Pelle ♣	W Alaska ♣ Amazon ♣ Antique ♣ Arizona ♣ Forte ♣ Lucente ♣ Sabrina ♣	X Ducale ♣ Ducale Velour ♣	Y Capri ♣ Cervo ♣ Copenhagen ♣ Cordovan ♣ Distressed ♣ Lucca ♣ Marissa ♣ Portofino ♣ Prima ♣ Riva ♣
---	---	--	---------------------------------	--	---	---	--

♣ Approved for Cal 133 upholstery; approval does not apply to chairs with plastic backs.

Check with your KnollTextiles or Spinneybeck Representative for changes or additions.

Eero Saarinen

Executive Armless Chairs

	description	seat h, min	seat h, max	width	d	h, min	h, max	textile fabric yds.	req. leather sq. ft.	weight
Designer(s): Eero Saarinen, 1946	72C-W Executive armless chair with wood legs and glides	18 3/4"		22 1/2"	20 1/2"	31 1/2"		2.0	35	13 lbs.
										
	72C Executive armless chair with plastic back, tubular legs and glides	18 3/4"		22"	20.5"	31 1/2"		1.3	12	16 lbs.
										

Order Code

<i>Example:</i>	72C-C-S-CD70-AL5008
72C	Open back chair, armless
C	Polished chrome leg
S	Split upholstery option
CD70	seat: Cordovan, Rembrandt Brown
AL5008	back: Alaska, Caribou

Note:
The Saarinen executive chairs are part of a collection. Please refer to Saarinen side chairs, lounge chairs and tables on beginning on pages 242 and 374.

Specify:

1. Pattern number
2. Leg base option
3. Cal 133 fire code option
4. Split upholstery option (add S)
5. Textile selection, seat
6. Textile selection, back

Wood Leg Finishes:

Ebonized Walnut (suffix D)
Light Oak (suffix LO)
Light Walnut (suffix LWA)
Pearwood (suffix P)
Polished Chrome (suffix C)
Reff Dark Cherry (suffix V314)

Tubular Leg Finishes:

Black (suffix BL)
Polished Chrome (C)

Plastic Back Finishes:

Black (suffix 1)
White (suffix 2)

Ordering Information

Caster option:

Hard wheel casters standard. For soft wheel casters, change -H to -R. No glide option on swivel models.

Split upholstery option:

The seat and back of the Saarinen Executive Chair can be specified in split upholstery. Indicate S before selected seat upholstery, followed by selected back upholstery. The price equals the price of the higher upholstery grade.

COM split fabric requirements:

Back upholstery: 1.5 yards
Seat upholstery: .75 yards

COL split leather requirements:

Back upholstery: 27 square feet
Seat upholstery: 13.5 square feet

Upholstery/COM information:

Prices shown include fabric or leather upholstery. Contact your Knoll representative for colors. Only approved Knoll Textiles and Spinneybeck leathers may be ordered. Customer's Own Material is available pending approval. For approval requirements, processing instructions and ordering information please see page 18.

Cal 133 Fire Code:

The Saarinen Executive Chairs comply with the California Technical Bulletin 133 standard if upholstered in Cal 133 approved upholstery. Specify suffix -C at end of pattern number and suffix -133 at end of textile selection. Upcharge applies, see page 19.

Maintenance:

See pages 28-29.

Note:

The Saarinen Executive Armless Chair is Greenguard certified

Construction:

Frame:

Molded reinforced polyurethane shell. Contoured plywood seat form.

Plastic Back:

Polycarbonate with a wet coat paint in black or white. Note that the seat of the plastic back version is slightly wider than the fully upholstered version.

Upholstery:

Urethane foam cushion.

Swivel base:

Five-star steel base in protective black epoxy finish. Stainless steel or optional black epoxy top caps.

Steel Leg base:

Four legs in seamless tubular steel with polished chrome or matte black powder coat.

Wood leg base:

Solid steam bent oak with a clear or stained finish. Finish is complementary match to Saarinen, Florence Knoll and Platner low tables

Casters:

2" twin wheel hard casters for use on carpeted floors. Wheel and housing components in black textured plastic. Optional soft casters for use on wood and other resilient flooring (black with grey housing).

Glides:

Molded nylon disk in stamped steel shroud.

pattern no.	upcharge	grades A	COM B	C	D	E	F	G	H	I	COL U	V	W	X	Y
72C-W-()-()		\$1,878.	\$1,933.	\$1,987.	\$2,048.	\$2,095.	\$2,131.	\$2,191.	\$2,305.	\$2,390.	\$2,876.	\$3,074.	\$3,476.	\$3,560.	\$3,658.
72C-(BL,C)-(1,2)-()		1,024.	1,060.	1,094.	1,131.	1,161.	1,182.	1,222.	1,293.	1,347.	1,268.	1,334.	1,467.	1,495.	1,527.

Approved KnollTextiles Grades/Fabrics

A Beacon Bocce Cat's Cradle Chance Common Ground ♣ Commuter Cloth ♣ Delite Dristi Hourglass Mariner Prep ♣ Presto ♣ Soliloquy Sonnet Stacks Trophy	B Abacus ♣ Argyle Bank Shot ♣ Belize Betwixt Bistro ♣ Boundary Cameo Chroma Chronicle Digit Ferry Forza Gala II Grande Grandview Holbrook Journey Keaton Knoll Felt ♣ Knoll Hopsack ♣ Ludlow Lyric	B continued Mini Stitch ♣ Night Life Paradigm Petal Pusher Pop Prairie Prim ♣ Ransom Radiance Ricochet Roam Rush Hour Soiree Spark ♣ Spinoff Nuance Spree Starry Night ♣ Summit Sutton Synth Tabloid Venue Versa Vinyl Westwood Wide Angle ♣ Zephyr Zipline	C continued Empire Stripe Enmesh ♣ Entourage Fable CR Fibra Greenwich Hudson Hula Hoop Kaleidoscope CR Kora CR Lagos Lore CR Magnolia Metro Milestone Noble Palisade Panache CR Quark Regard CR Rountrip Sandpiper Sequin CR Sinclair Smart Spectator Spot On Star Struck ♣ Stepping Stones Swing Tilden Tower Grid Transition ♣ Treble CR Vibe Zari CR	D Compass CR Coterie Eclat Weave Hologram Island Masquerade Menagerie Origins Satellite Satin Chisel Tara Theory Woodland Zoom	E Highland Ikat Square Ikat Stripe Kampala Katazome Luberon Mamba Marquee Sherman Shima Tryst Whip
---	--	--	--	---	---

Spinneybeck Leather



H Arno Bavaria Constance Cornaro Eclipse Glider Icon Intrigue Liberty Mod Plaid Rivington Soon Topography Totem Tweed Frieze	I Aswan Canaan Cato Diamond Days Dynamic Gates Ita Jaipur Knoll Velvet North Island Olema Piper Rutledge Tudor Vermeer Walker Worth Zimba	U Vicenza ♣ Volo ♣	V Acqua ♣ Andes ♣ Embossed Tipped ♣ España ♣ Velluto Pelle ♣	W Alaska ♣ Amazon ♣ Antique ♣ Arizona ♣ Forte ♣ Lucente ♣ Sabrina ♣	X Ducale ♣ Ducale Velour ♣	Y Capri ♣ Cervo ♣ Copenhagen ♣ Cordovan ♣ Distressed ♣ Lucca ♣ Marissa ♣ Portofino ♣ Prima ♣ Riva ♣
--	--	---------------------------------	--	---	---	--

♣ Approved for Cal 133 upholstery; approval does not apply to chairs with plastic backs.

Check with your KnollTextiles or Spinneybeck Representative for changes or additions.

Eero Saarinen

Womb Chair, Ottoman and Settee

	description	seat h	arm h	w	d	h	textile fabric yds.	req. leather sq. ft.	weight
Designer(s): Eero Saarinen, 1946	70L Womb chair 	16"	20 1/2"	40"	34"	35 1/2"	7.2	165	36 lbs.
	74Y Ottoman 			25 1/2"	20"	16"	2.1	55	13 lbs.



Order Code

Example:	70LM-BL-K530/4
70LM	Medium womb chair
BL	Black base
K530/4	Lyonese Velvet, Cognac

Note:
The Womb chair and ottoman and Womb Settee are part of a collection. Please refer to Saarinen side and executive chairs and tables on pages 242 and 374.

Specify:

1. Pattern number/size
2. Base finish selection
3. Cal 133 option
4. Split upholstery option (add S)
5. Textile selection

Ordering Information

Base finishes:
Black (suffix BL)
 Polished Chrome (suffix C)

Upholstery/COM information:
Prices shown include fabric or leather upholstery. Contact your Knoll representative for colors. Only approved KnollTextiles and Spinneybeck leathers may be ordered.

Customer's Own Material is available pending approval. For approval requirements, processing instructions and ordering information please see page 18.

 **KnollStudio 20-day Program:**
The standard Womb chair and ottoman are available in a chrome finish on the 20-day program upholstered with in-stock KnollTextile. For more information, please consult pages 30-33.

Split upholstery option:
The surround and cushions of the Womb chair and ottoman and Womb settee may be specified with split upholstery. Indicate S before selected surround upholstery, followed by selected cushion upholstery. Price equals the higher upholstery grade.

COM split fabric requirements:
75% Womb chair body: 3.5 yards
75% Womb chair seat/back: 1.25 yards
85% Womb chair body: 3.75 yards
85% Womb chair seat/back: 1.25 yards
85% Ottoman body: 1 yard
85% Ottoman cushion: .75 yards
100% Womb chair body: 5.50 yards
100% Womb chair seat/back: 2 yards
100% Ottoman body: 1 yard
100% Ottoman cushion: 1.25 yards
100% Womb settee body: 9 yards
100% Womb settee seat/back: 2.6 yards

COL split leather requirements:
75% Womb chair body: 90 square ft
75% Womb chair seat/back: 23 square ft
85% Womb chair body: 96 square ft
85% Womb chair seat/back: 25 square ft
85% Ottoman body: 48 square ft
85% Ottoman cushion: 25 square ft
100% Womb chair body: 110 square ft
100% Womb chair seat/back: 40 square ft
100% Ottoman body: 27.5 square ft
100% Ottoman cushion: 27.5 square ft
100% Womb settee body: 275 square ft
100% Womb settee seat/back: 110 square ft

Maintenance:
See pages 28-29.

Cal 133 Fire Code #:
The Womb Chair, Ottoman, and Settee comply with the California Technical Bulletin 133 standard if upholstered in Cal 133 approved upholstery. Specify suffix -C at end of pattern number and suffix -133 at end of textile selection. Upcharge applies, see page 19.

Note:
The Saarinen Womb chair and ottoman and Womb settee are Greenguard certified.

pattern no.	grades		COM											
	A	B	C	D	E	F	G	H	I	U	V	W	X	Y
70L-(BL,C)-() 	\$5,326.	\$5,593.	\$5,864.	\$6,163.	\$6,234.	\$6,391.	\$6,563.	\$6,996.	\$7,790.	\$8,881.	\$9,781.	\$12,088.	\$12,489.	\$12,735.

74Y-(BL,C)-() 	1,570.	1,637.	1,709.	1,760.	1,806.	1,848.	1,893.	2,003.	2,205.	2,399.	2,661.	3,230.	3,335.	3,398.
---	--------	--------	--------	--------	--------	--------	--------	--------	--------	--------	--------	--------	--------	--------

Construction

Base:
Steel wire with a polished chrome finish or matte black powder-coat.

Frame and upholstery:
Foam over molded, reinforced fiberglass shell on chair. Foam cushion over molded plywood platform on ottoman. Separate seat, back, and ottoman cushions constructed of polyester fiber with foam core.





























Glides:
Stainless steel and nylon articulating glides.

Medium and Child's Womb Chairs:
Medium Womb chair and ottoman are 85% scale of standard Womb chair. Child's Womb chair is 75% scale of standard chair. Child's chair does not have accompanying ottoman.

Approved KnollTextiles Grades/Fabrics

A	Alignment  Bocce Cat's Cradle Common Ground  Commuter Cloth  Delite Hourglass Mariner Prep Soliloquy * Sonnet Stacks	C	Atlas Autobahn Biota Cairo Charm Circa Classic Boucle Dahlia CR Durand Earthwork Echo Empire Stripe * Entourage * Fibra Greenwich Hudson Hula Hoop Kaleidoscope CR Kora CR * Lagos Legend CR Lore CR Metro Milestone Palisade Posh Quark Regard CR Roundtrip Sandpiper Sequin CR * Smart Spectator * Spot On * Star Struck Swing Tilden Tower Grid Transition  Treble CR Vibe * Zari CR *	D	Compass CR Coterie Eclat Weave Island Masquerade Menagerie Origins Satellite Tara Theory Woodland	E	Highland Ikat Square Ikat Stripe Kampala Katazome Kimono Luberon Mamba Marquee Meroe Shima Whip	F	Atelier Biscayne Coco Cornaro * Eclipse Glider Icon Intrigue Liberty Mod Plaid Rivington Soon Topography	G	Arabella Djenne Gibson Hampshire * Haze Kamani Melange Sablon Serendipity Spencer Straie Stripe Ultrasuede  Utrillo	H	Arno Bavaria Constance Firefly Gezelle Magritte Rosemond	I	Aswan Byron * Canaan Cato Cummings * Diamond Days Dynamic Gates Ita Jaipur Knoll Velvet Olema Piper Rutledge Sandis Vermeer Walker Worth Zimba
----------	--	----------	---	----------	---	----------	--	----------	--	----------	---	----------	--	----------	--

Spinneybeck Leather

U	Vicenza  Volo 	X	Ducale  + Ducale Velour 
V	Acqua  Andes  Embossed Tipped  España  + Velluto Pelle 	Y	Capri  Cervo  Copenhagen  Cordovan  Distressed  + Lucca  Marissa  Portofino  + Prima  + Riva  Torello 
W	Alaska  Amazon  Arizona  Antique  Derby  Forte  Lucente  Sabrina 		

Note: All KnollTextiles and COM fabrics are railroaded on the Womb chair.

* Approved for chair and ottoman cushion upholstery only.
+ Not approved for small and medium Womb chairs and ottomans.
 Approved for Cal 133 upholstery.

Check with your KnollTextile or Spinneybeck Representative for any changes or additions.

Eero Saarinen

Womb Chair, Ottoman and Settee

	description	seat h	arm h	w	d	h	textile fabric yds.	req. leather sq. ft.	weight
<i>Designer(s):</i> Eero Saarinen, 1946	73L Womb Settee	16"	20½"	62¾"	34"	35½"	11.4	385	–

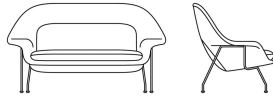

Order Code

<i>Example:</i>	70LM-BL-K530/4
70LM	Medium womb chair
BL	Black base
K530/4	Lyonese Velvet, Cognac

Note:
The Womb chair and ottoman and Womb Settee are part of a collection. Please refer to Saarinen side and executive chairs and tables on pages 242 and 374.

Specify:

1. Pattern number/size
2. Base finish selection
3. Cal 133 option
4. Split upholstery option (add S)
5. Textile selection

Ordering Information

Base finishes:
Black (suffix BL)
☞ Polished Chrome (suffix C)

Upholstery/COM information:
Prices shown include fabric or leather upholstery. Contact your Knoll representative for colors. Only approved KnollTextiles and Spinneybeck leathers may be ordered.

Customer's Own Material is available pending approval. For approval requirements, processing instructions and ordering information please see page 18.

☞ **KnollStudio 20-day Program:**
The standard Womb chair and ottoman are available in a chrome finish on the 20-day program upholstered with in-stock KnollTextile. For more information, please consult pages 30-33.

Split upholstery option:
The surround and cushions of the Womb chair and ottoman and Womb settee may be specified with split upholstery. Indicate S before selected surround upholstery, followed by selected cushion upholstery. Price equals the higher upholstery grade.

COM split fabric requirements:
75% Womb chair body: 3.5 yards
75% Womb chair seat/back: 1.25 yards
85% Womb chair body: 3.75 yards
85% Womb chair seat/back: 1.25 yards
85% Ottoman body: 1 yard
85% Ottoman cushion: .75 yards
100% Womb chair body: 5.50 yards
100% Womb chair seat/back: 2 yards
100% Ottoman body: 1 yard
100% Ottoman cushion: 1.25 yards
100% Womb settee body: 9 yards
100% Womb settee seat/back: 2.6 yards

COL split leather requirements:
75% Womb chair body: 90 square ft
75% Womb chair seat/back: 23 square ft
85% Womb chair body: 96 square ft
85% Womb chair seat/back: 25 square ft
85% Ottoman body: 48 square ft
85% Ottoman cushion: 25 square ft
100% Womb chair body: 110 square ft
100% Womb chair seat/back: 40 square ft
100% Ottoman body: 27.5 square ft
100% Ottoman cushion: 27.5 square ft
100% Womb settee body: 275 square ft
100% Womb settee seat/back: 110 square ft

Maintenance:
See pages 28-29.

Cal 133 Fire Code ♣:
The Womb Chair, Ottoman, and Settee comply with the California Technical Bulletin 133 standard if upholstered in Cal 133 approved upholstery. Specify suffix -C at end of pattern number and suffix -133 at end of textile selection. Upcharge applies, see page 19.

Note:
The Saarinen Womb chair and ottoman and Womb settee are Greenguard certified.

pattern no.	grades	COM	A	B	C	D	E	F	G	H	I	U	V	W	X	Y
73L-(BL,C)-()			\$8,274.	\$8,688.	\$9,109.	\$9,418.	\$9,683.	\$9,928.	\$10,195.	\$10,867.	\$12,101.	\$13,795.	\$15,194.	\$18,778.	\$19,400.	\$19,782.

Construction

Base:
Steel wire with a polished chrome finish or matte black powder-coat.

Frame and upholstery:
Foam over molded, reinforced fiberglass shell on chair. Foam cushion over molded plywood platform on ottoman. Separate seat, back, and ottoman cushions constructed of polyester fiber with foam core.

Glides:
Stainless steel and nylon articulating glides.

Medium and Child's Womb Chairs:
Medium Womb chair and ottoman are 85% scale of standard Womb chair. Child's Womb chair is 75% scale of standard chair. Child's chair does not have accompanying ottoman.

Approved KnollTextiles Grades/Fabrics

A	Alignment ‡ Bocce Cat's Cradle Common Ground ‡ Commuter Cloth ‡ Delite Hourglass Mariner Prep Soliloquy * Sonnet Stacks	C	Atlas Autobahn Biota Cairo Charm Circa Classic Boucle Dahlia CR Durand Earthwork Echo Empire Stripe * Entourage * Fibra Greenwich Hudson Hula Hoop Kaleidoscope CR Kora CR * Lagos Legend CR Lore CR Metro Milestone Palisade Posh Quark Regard CR Roundtrip Sandpiper Sequin CR * Smart Spectator * Spot On * Star Struck Swing Tilden Tower Grid Transition ‡ Treble CR Vibe * Zari CR *	D	Compass CR Coterie Eclat Weave Island Masquerade Menagerie Origins Satellite Tara Theory Woodland	E	Highland Ikat Square Ikat Stripe Kampala Katazome Kimono Luberon Mamba Marquee Meroe Shima Whip	F	Atelier Biscayne Coco Cornaro * Eclipse Glider Icon Intrigue Liberty Mod Plaid Rivington Soon Topography	G	Arabella Djenne Gibson Hampshire * Haze Kamani Melange Sablon Serendipity Spencer Straie Stripe Ultrasuede ‡ Utrillo	H	Arno Bavaria Constance Firefly Gezelle Magritte Rosemond	I	Aswan Byron * Canaan Cato Cummings * Diamond Days Dynamic Gates Ita Jaipur Knoll Velvet Olema Piper Rutledge Sandis Vermeer Walker Worth Zimba
----------	--	----------	---	----------	---	----------	--	----------	--	----------	--	----------	--	----------	--

Spinneybeck Leather

U	Vicenza ‡ Volo ‡	X	Ducale ‡+ Ducale Velour ‡
V	Acqua ‡ Andes ‡ Embossed Tipped ‡ España ‡+ Velluto Pelle ‡	Y	Capri ‡ Cervo ‡ Copenhagen ‡ Cordovan ‡ Distressed ‡+ Lucca ‡ Marissa ‡ Portofino ‡+ Prima ‡+ Riva ‡ Torello ‡
W	Alaska ‡ Amazon ‡ Arizona ‡ Antique ‡ Derby ‡ Forte ‡ Lucente ‡ Sabrina ‡		



Note: All KnollTextiles and COM fabrics are railroaded on the Womb chair.

* Approved for chair and ottoman cushion upholstery only.
+ Not approved for small and medium Womb chairs and ottomans.
‡ Approved for Cal 133 upholstery.

Check with your KnollTextile or Spinneybeck Representative for any changes or additions.

Eero Saarinen

Womb Chair, Ottoman and Settee

	description	seat h	arm h	w	d	h	textile fabric yds.	req. leather sq. ft.	weight
Designer(s): Eero Saarinen, 1946	70LM Medium Womb chair 	15"	18"	35"	31"	31 1/4"	5	96	31 lbs.
	74YM Medium ottoman 			21"	17 1/2"	14 1/4"	1.7	48	11 lbs.



Order Code

<i>Example:</i>	70LM-BL-K530/4
70LM	Medium womb chair
BL	Black base
K530/4	Lyonese Velvet, Cognac

Note:
The Womb chair and ottoman and Womb Settee are part of a collection. Please refer to Saarinen side and executive chairs and tables on pages 242 and 374.

Specify:

1. Pattern number/size
2. Base finish selection
3. Cal 133 option
4. Split upholstery option (add S)
5. Textile selection

Ordering Information

Base finishes:
Black (suffix BL)
 Polished Chrome (suffix C)

Upholstery/COM information:
Prices shown include fabric or leather upholstery. Contact your Knoll representative for colors. Only approved KnollTextiles and Spinneybeck leathers may be ordered.

Customer's Own Material is available pending approval. For approval requirements, processing instructions and ordering information please see page 18.

 **KnollStudio 20-day Program:**
The standard Womb chair and ottoman are available in a chrome finish on the 20-day program upholstered with in-stock KnollTextile. For more information, please consult pages 30-33.

Split upholstery option:
The surround and cushions of the Womb chair and ottoman and Womb settee may be specified with split upholstery. Indicate S before selected surround upholstery, followed by selected cushion upholstery. Price equals the higher upholstery grade.

COM split fabric requirements:
75% Womb chair body: 3.5 yards
75% Womb chair seat/back: 1.25 yards
85% Womb chair body: 3.75 yards
85% Womb chair seat/back: 1.25 yards
85% Ottoman body: 1 yard
85% Ottoman cushion: .75 yards
100% Womb chair body: 5.50 yards
100% Womb chair seat/back: 2 yards
100% Ottoman body: 1 yard
100% Ottoman cushion: 1.25 yards
100% Womb settee body: 9 yards
100% Womb settee seat/back: 2.6 yards

COL split leather requirements:
75% Womb chair body: 90 square ft
75% Womb chair seat/back: 23 square ft
85% Womb chair body: 96 square ft
85% Womb chair seat/back: 25 square ft
85% Ottoman body: 48 square ft
85% Ottoman cushion: 25 square ft
100% Womb chair body: 110 square ft
100% Womb chair seat/back: 40 square ft
100% Ottoman body: 27.5 square ft
100% Ottoman cushion: 27.5 square ft
100% Womb settee body: 275 square ft
100% Womb settee seat/back: 110 square ft

Maintenance:
See pages 28-29.

Cal 133 Fire Code:
The Womb Chair, Ottoman, and Settee comply with the California Technical Bulletin 133 standard if upholstered in Cal 133 approved upholstery. Specify suffix -C at end of pattern number and suffix -133 at end of textile selection. Upcharge applies, see page 19.

Note:
The Saarinen Womb chair and ottoman and Womb settee are Greenguard certified.

pattern no.	grades		COM											
	A	B	C	D	E	F	G	H	I	U	V	W	X	Y
70LM-(BL,C)-()	\$5,024.	\$5,276.	\$5,531.	\$5,720.	\$5,879.	\$6,029.	\$6,191.	\$6,597.	\$7,349.	\$8,378.	\$9,228.	\$11,405.	\$11,781.	\$12,015.
74YM-(BL,C)-()	1,482.	1,545.	1,615.	1,659.	1,704.	1,742.	1,785.	1,888.	2,081.	2,264.	2,482.	3,047.	3,146.	3,205.

Construction

Base:
Steel wire with a polished chrome finish or matte black powder-coat.

Frame and upholstery:
Foam over molded, reinforced fiberglass shell on chair. Foam cushion over molded plywood platform on ottoman. Separate seat, back, and ottoman cushions constructed of polyester fiber with foam core.

Glides:
Stainless steel and nylon articulating glides.

Medium and Child's Womb Chairs:
Medium Womb chair and ottoman are 85% scale of standard Womb chair. Child's Womb chair is 75% scale of standard chair. Child's chair does not have accompanying ottoman.

Approved KnollTextiles Grades/Fabrics

- A** Alignment ‡
Bocce
Cat's Cradle
Common Ground ‡
Commuter Cloth ‡
Delite
Hourglass
Mariner
Prep
Soliloquy *
Sonnet
Stacks
- B** Abacus ‡
Argyle
Bank Shot
Belize
Betwixt
Bistro ‡
Cameo
Chronicle
Digit
Dovetail ‡
Ferry
Grande
Grandview
Holbrook
Journey
Keaton
Knoll Felt
Knoll Hopsack
Ludlow
Lyric
Mini Stitch ‡
Night Life
Nonchalant CR
Paradigm
Pogo
Prairie
Prim ‡
Radiance
Ransom
Roam
Rush Hour
Soiree
Spark
Spree
Starry Night ‡
Summit
Sutton ‡
Tabloid
Versa
Westwood
Zipline
- C** Atlas
Autobahn
Biota
Cairo
Charm
Circa
Classic Boucle
Dahlia CR
Durand
Earthwork
Echo
Empire Stripe *
Entourage *
Fibra
Greenwich
Hudson
Hula Hoop
Kaleidoscope CR
Kora CR *
Lagos
Legend CR
Lore CR
Metro
Milestone
Palisade
Posh
Quark
Regard CR
Roundtrip
Sandpiper
Sequin CR *
Smart
Spectator *
Spot On *
Star Struck
Swing
Tilden
Tower Grid
Transition ‡
Treble CR
Vibe *
Zari CR *
- D** Compass CR
Coterie
Eclat Weave
Island
Masquerade
Menagerie
Origins
Satellite
Tara
Theory
Woodland
- E** Highland
Ikat Square
Ikat Stripe
Kampala
Katazome
Kimono
Luberon
Mamba
Marquee
Meroe
Shima
Whip
- F** Atelier
Biscayne
Coco
Cornaro *
Eclipse
Glider
Icon
Intrigue
Liberty
Mod Plaid
Rivington
Soon
Topography
- G** Arabella
Djenne
Gibson
Hampshire *
Haze
Kamani
Melange
Sablon
Serendipity
Spencer
Straie Stripe
Ultrasuede ‡
Utrillo
- H** Arno
Bavaria
Constance
Firefly
Gezelle
Magritte
Rosemond
- I** Aswan
Byron *
Canaan
Cato
Cummings *
Diamond Days
Dynamic
Gates
Ita
Jaipur
Knoll Velvet
Olema
Piper
Rutledge
Sandis
Vermeer
Walker
Worth
Zimba

Spinneybeck Leather

- U** Vicenza ‡
Volo ‡
- V** Acqua ‡
Andes ‡
Embossed Tipped ‡
España ‡+
Velluto Pelle ‡
- W** Alaska ‡
Amazon ‡
Arizona ‡
Antique ‡
Derby ‡
Forte ‡
Lucente ‡
Sabrina ‡
- X** Ducale ‡+
Ducale Velour ‡
- Y** Capri ‡
Cervo ‡
Copenhagen ‡
Cordovan ‡
Distressed ‡+
Lucca ‡
Marissa ‡
Portofino ‡+
Prima ‡+
Riva ‡
Torello ‡

Note: All KnollTextiles and COM fabrics are railroaded on the Womb chair.

* Approved for chair and ottoman cushion upholstery only.
+ Not approved for small and medium Womb chairs and ottomans.
‡ Approved for Cal 133 upholstery.

Check with your KnollTextile or Spinneybeck Representative for any changes or additions.

Eero Saarinen

Womb Chair, Ottoman and Settee

	description	seat h	arm h	w	d	h	textile fabric yds.	req. leather sq. ft.	weight
Designer(s): Eero Saarinen, 1946	70LS Child's Womb chair	14 1/2"	17"	31"	28"	27 1/4"	5	90	27 lbs.



Order Code

<i>Example:</i>	70LM-BL-K530/4
70LM	Medium womb chair
BL	Black base
K530/4	Lyonese Velvet, Cognac

Note:
The Womb chair and ottoman and Womb Settee are part of a collection. Please refer to Saarinen side and executive chairs and tables on pages 242 and 374.

Specify:

1. Pattern number/size
2. Base finish selection
3. Cal 133 option
4. Split upholstery option (add S)
5. Textile selection

Ordering Information

Base finishes:
Black (suffix BL)
☞ Polished Chrome (suffix C)

Upholstery/COM information:
Prices shown include fabric or leather upholstery. Contact your Knoll representative for colors. Only approved KnollTextiles and Spinneybeck leathers may be ordered.

Customer's Own Material is available pending approval. For approval requirements, processing instructions and ordering information please see page 18.

☞ **KnollStudio 20-day Program:**
The standard Womb chair and ottoman are available in a chrome finish on the 20-day program upholstered with in-stock KnollTextile. For more information, please consult pages 30-33.

Split upholstery option:
The surround and cushions of the Womb chair and ottoman and Womb settee may be specified with split upholstery. Indicate S before selected surround upholstery, followed by selected cushion upholstery. Price equals the higher upholstery grade.

COM split fabric requirements:
75% Womb chair body: 3.5 yards
75% Womb chair seat/back: 1.25 yards
85% Womb chair body: 3.75 yards
85% Womb chair seat/back: 1.25 yards
85% Ottoman body: 1 yard
85% Ottoman cushion: .75 yards
100% Womb chair body: 5.50 yards
100% Womb chair seat/back: 2 yards
100% Ottoman body: 1 yard
100% Ottoman cushion: 1.25 yards
100% Womb settee body: 9 yards
100% Womb settee seat/back: 2.6 yards

COL split leather requirements:
75% Womb chair body: 90 square ft
75% Womb chair seat/back: 23 square ft
85% Womb chair body: 96 square ft
85% Womb chair seat/back: 25 square ft
85% Ottoman body: 48 square ft
85% Ottoman cushion: 25 square ft
100% Womb chair body: 110 square ft
100% Womb chair seat/back: 40 square ft
100% Ottoman body: 27.5 square ft
100% Ottoman cushion: 27.5 square ft
100% Womb settee body: 275 square ft
100% Womb settee seat/back: 110 square ft

Maintenance:
See pages 28-29.

Cal 133 Fire Code ♣:
The Womb Chair, Ottoman, and Settee comply with the California Technical Bulletin 133 standard if upholstered in Cal 133 approved upholstery. Specify suffix -C at end of pattern number and suffix -133 at end of textile selection. Upcharge applies, see page 19.

Note:
The Saarinen Womb chair and ottoman and Womb settee are Greenguard certified.

pattern no.	grades	COM								COL				
	A	B	C	D	E	F	G	H	I	U	V	W	X	Y
70LS-(BL,C)-()	\$4,522.	\$4,748.	\$4,977.	\$5,148.	\$5,293.	\$5,426.	\$5,573.	\$5,938.	\$6,615.	\$7,540.	\$8,305.	\$10,264.	\$10,604.	\$10,813.

Construction

Base:
Steel wire with a polished chrome finish or matte black powder-coat.

Frame and upholstery:
Foam over molded, reinforced fiberglass shell on chair. Foam cushion over molded plywood platform on ottoman. Separate seat, back, and ottoman cushions constructed of polyester fiber with foam core.

Glides:
Stainless steel and nylon articulating glides.

Medium and Child's Womb Chairs:
Medium Womb chair and ottoman are 85% scale of standard Womb chair. Child's Womb chair is 75% scale of standard chair. Child's chair does not have accompanying ottoman.

Approved KnollTextiles Grades/Fabrics

A	Alignment ‡ Bocce Cat's Cradle Common Ground ‡ Commuter Cloth ‡ Delite Hourglass Mariner Prep Soliloquy * Sonnet Stacks	C	Atlas Autobahn Biota Cairo Charm Circa Classic Boucle Dahlia CR Durand Earthwork Echo Empire Stripe * Entourage * Fibra Greenwich Hudson Hula Hoop Kaleidoscope CR Kora CR * Lagos Legend CR Lore CR Metro Milestone Palisade Posh Quark Regard CR Roundtrip Sandpiper Sequin CR * Smart Spectator * Spot On * Star Struck Swing Tilden Tower Grid Transition ‡ Treble CR Vibe * Zari CR *	D	Compass CR Coterie Eclat Weave Island Masquerade Menagerie Origins Satellite Tara Theory Woodland	E	Highland Ikat Square Ikat Stripe Kampala Katazome Kimono Luberon Mamba Marquee Meroe Shima Whip	F	Atelier Biscayne Coco Cornaro * Eclipse Glider Icon Intrigue Liberty Mod Plaid Rivington Soon Topography	G	Arabella Djenne Gibson Hampshire * Haze Kamani Melange Sablon Serendipity Spencer Straie Stripe Ultrasuede ‡ Utrillo	H	Arno Bavaria Constance Firefly Gezelle Magritte Rosemond	I	Aswan Byron * Canaan Cato Cummings * Diamond Days Dynamic Gates Ita Jaipur Knoll Velvet Olema Piper Rutledge Sandis Vermeer Walker Worth Zimba
----------	--	----------	---	----------	---	----------	--	----------	--	----------	--	----------	--	----------	--

Spinneybeck Leather

U	Vicenza ‡ Volo ‡	X	Ducale ‡+ Ducale Velour ‡
V	Acqua ‡ Andes ‡ Embossed Tipped ‡ España ‡+ Velluto Pelle ‡	Y	Capri ‡ Cervo ‡ Copenhagen ‡ Cordovan ‡ Distressed ‡+ Lucca ‡ Marissa ‡ Portofino ‡+ Prima ‡+ Riva ‡ Torello ‡
W	Alaska ‡ Amazon ‡ Arizona ‡ Antique ‡ Derby ‡ Forte ‡ Lucente ‡ Sabrina ‡		



Note: All KnollTextiles and COM fabrics are railroaded on the Womb chair.

* Approved for chair and ottoman cushion upholstery only.
+ Not approved for small and medium Womb chairs and ottomans.
‡ Approved for Cal 133 upholstery.

Check with your KnollTextile or Spinneybeck Representative for any changes or additions.

Richard Schultz

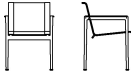
1966 Collection® Dining Chairs

	description	seat h	arm h	w	d	h	textile fabric yds.	weight
Designer(s): Richard Schultz, 1966 	1966-45H Dining chair with arms	18"	25"	23"	24 1/4"	31"		22 lbs.
								
	1966-45HCOV Dining chair with arms cover	–	–	–	–	–		–
	1966-46H Dining chair, armless	18"		19"	24 1/4"	31"		20 lbs.
								
	1966-46HCOV Dining chair, armless, cover							
	1966-45P Chair pad for 1966-45H, 46H, 46C, 46B						1.25	



Order Code

<i>Example:</i>	1966-45H-B-W-W
1966-45H	Dining chair with arms
B	Brown straps
W	White mesh
W	White frame

Specify:

1. Pattern number
2. Strap color
3. Mesh color
4. Frame color

Ordering Information

Strap finishes:

White (suffix W)
 Brown (suffix B)
 Grey (suffix G)
 Onyx (suffix O)
 Sand (suffix S)
 Bronze (suffix Z)

Mesh finishes:

White (suffix W)
 Grey Tone (suffix T)
 Onyx (suffix O)
 Aluminum (suffix A)
 Bronze (suffix Z)
 Chestnut (suffix N)

Frame finishes:

Blue (suffix BLU)
 Chestnut (suffix N)
 Dark Bronze (suffix 14)
 Green (suffix 007)
 Light Bronze (suffix 13)
 Lime Green (suffix LGR)
 Onyx (suffix O)
 Orange (suffix ORG)
 Plum (suffix PLM)
 Sky Blue (suffix 3)
 Warm Bronze (suffix 16)
 Warm Wood (suffix 12)
 Weatherable Silver (suffix S)
 White (suffix W)
 Yellow (suffix YEL)

Maintenance:

See pages 28-29.

Upholstery/COM information:

Prices shown include fabric upholstery only. Contact your Knoll representative for colors.

Customer's Own Material is available pending approval. For approval requirements, processing instructions and ordering information, please see page 18

pattern no.		COM	
1966-45H-(-)-(-)	\$1,861.	B	C
1966-45HCOV	313.		
1966-46H-(-)-(-)	1,861.		
1966-46HCOV	313.		
1966-45P		534.	560.

Construction

Frame:

Frame is aluminum castings and extrusions welded and glued together using a two-part epoxy. Finished in highly durable weather resistant polyester powder coat paint.

Seat:

Woven vinyl coated polyester mesh is sewn to pure vinyl straps using Teflon thread to form the seat and back. Stainless steel supports provides shape and is attached to the frame with stainless steel connectors.

Glides:

Clear butyrate plastic.

Approved KnollTextiles Grades/Fabrics

B

Belize
Prairie
Vinyl

C

Baxter
Noble
Sinclair

Check with your KnollTextiles Representative for changes or additions.

Richard Schultz

1966 Collection® Barstools

Designer(s):
Richard Schultz, 1966

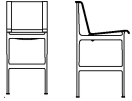

description	seat h	w	d	h	textile fabric yds.	weight
1966-46C Counter height armless barstool	26"	19"	24 1/4"	39 1/4"		24 lbs.
						
1966-46CCOV Counter height armless barstool cover						
1966-46B Bar height armless barstool	31"	19"	24 1/4"	44 1/4"		24 lbs.
						
1966-46BCOV Bar height armless barstool cover						
1966-45P Chair pad for 1966-45H, 46H, 46C, 46B					1.25	

Order Code

<i>Example:</i> 1966-46B-O-O-O
1966-46B Bar height barstool
O Onyx strap
O Onyx mesh
O Onyx frame

Specify:

1. Pattern number
2. Strap color
3. Mesh color
4. Frame color

Ordering Information

Strap finishes:

White (suffix W)
Brown (suffix B)
Grey (suffix G)
Onyx (suffix O)
Sand (suffix S)
Bronze (suffix Z)

Mesh finishes:

White (suffix W)
Grey Tone (suffix T)
Onyx (suffix O)
Aluminum (suffix A)
Bronze (suffix Z)
Chestnut (suffix N)

Frame finishes:

Blue (suffix BLU)
Chestnut (suffix N)
Dark Bronze (suffix 14)
Green (suffix 007)
Light Bronze (suffix 13)
Lime Green (suffix LGR)
Onyx (suffix O)
Orange (suffix ORG)
Plum (suffix PLM)
Sky Blue (suffix 3)
Warm Bronze (suffix 16)
Warm Wood (suffix 12)
Weatherable Silver (suffix S)
White (suffix W)
Yellow (suffix YEL)

Maintenance:

See pages 28-29.

Upholstery/COM information:

Prices shown include fabric upholstery only. Contact your Knoll representative for colors.

Customer's Own Material is available pending approval. For approval requirements, processing instructions and ordering information, please see page 18

pattern no.		COM	
1966-46C-(-)-(-)	\$2,096.	B	C
1966-46CCOV	400.		
1966-46B-(-)-(-)	2,333.		
1966-46BCOV	437.		
1966-45P		534.	560.

Construction

Frame:
 Frame is aluminum castings and extrusions welded and glued together using a two-part epoxy. Finished in highly durable weather resistant polyester powder coat paint.

Seat:
 Woven vinyl coated polyester mesh is sewn to pure vinyl straps using Teflon thread to form the seat and back. Stainless steel supports provides shape and is attached to the frame with stainless steel connectors.

Glides:
 Clear butyrate plastic.

Approved KnollTextiles Grades/Fabrics

B
 Belize
 Prairie
 Vinyl

C
 Baxter
 Noble
 Sinclair

Check with your KnollTextiles Representative for changes or additions.

Richard Schultz

1966 Collection® Lounge Seating

Designer(s):
Richard Schultz, 1966



description	seat h	arm h	w	d	h	textile fabric yds.	weight
1966-25 Lounge chair with arms	14"	20½"	26"	28¼"	26"		24 lbs.
1966-25COV Lounge chair with arms, cover							
1966-255 Two seat lounge chair with arms	14"	20½"	46"	28¼"	26"		28 lbs.
1966-255COV Two seat lounge chair with arms, cover							
1966-355 Three seat lounge chair with arms	14"	20½"	66"	28¼"	26"		32 lbs.
1966-355COV Three seat lounge chair with arms, cover							
1966-250 ottoman			23"	27"	14"		12 lbs.
1966-250COV ottoman cover							
1966-25P Chair pad for 1966-25, 255, 355						1.5	
1966-250P Ottoman pad for 1966-250						1.25	

Order Code

<i>Example:</i>	1966-25-G-T-S
1966-25	Lounge chair with arms
G	Grey strap
T	Grey Tone mesh
S	Weatherable Silver frame

Specify:

1. Pattern number
2. Strap color
3. Mesh color
4. Frame color

Ordering Information

Strap finishes:

White (suffix W)
Brown (suffix B)
Grey (suffix G)
Onyx (suffix O)
Sand (suffix S)
Bronze (suffix Z)

Mesh finishes:

White (suffix W)
Grey Tone (suffix T)
Onyx (suffix O)
Aluminum (suffix A)
Bronze (suffix Z)
Chestnut (suffix N)

Frame finishes:

Blue (suffix BLU)
Chestnut (suffix N)
Dark Bronze (suffix 14)
Green (suffix 007)
Light Bronze (suffix 13)
Lime Green (suffix LGR)
Onyx (suffix O)
Orange (suffix ORG)
Plum (suffix PLM)
Sky Blue (suffix 3)
Warm Bronze (suffix 16)
Warm Wood (suffix 12)
Weatherable Silver (suffix S)
White (suffix W)
Yellow (suffix YEL)

Maintenance:

See pages 28-29.

Upholstery/COM information:

Prices shown include fabric upholstery only. Contact your Knoll representative for colors.

Customer's Own Material is available pending approval. For approval requirements, processing instructions and ordering information, please see page 18

pattern no.		COM	
		B	C
1966-25-()-()-()	\$2,037.		
1966-25COV	369.		
1966-255-()-()-()	2,785.		
1966-255COV	653.		
1966-355-()-()-()	3,676.		
1966-355COV	899.		
1966-250-()-()-()	1,801.		
1966-250COV	478.		
1966-25P		460.	492.
1966-250P		427.	454.

Construction

Frame:

Frame is aluminum castings and extrusions welded and glued together using a two-part epoxy. Finished in highly durable weather resistant polyester powder coat paint.

Seat:

Woven vinyl coated polyester mesh is sewn to pure vinyl straps using Teflon thread to form the seat and back. Stainless steel supports provides shape and is attached to the frame with stainless steel connectors.

Glides:

Clear butyrate plastic.

Approved KnollTextiles Grades/Fabrics

B

Belize
Prairie
Vinyl



C

Baxter
Noble
Sinclair

Check with your KnollTextiles Representative for changes or additions.

Richard Schultz

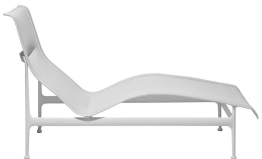
1966 Collection® Chaise Lounge Chairs

	description	seat h	w	d	h	textile fabric yds.	weight
<i>Designer(s):</i> Richard Schultz, 1966  	1966-41 Contour chaise lounge	13"	24½"	58"	33¾"		32 lbs.
	1966-41COV Contour chaise lounge cover						
	1966-42 Adjustable chaise lounge	14¼"	25½"	76"	36"		37 lbs.
	1966-42COV Adjustable chaise lounge cover						
	1966-41P 1966 Contour chaise pad					2.5	
	1966-42P 1966 Adjustable chaise pad					2.5	

Order Code

<i>Example:</i>	1966-41-W-W-W
1966-41	Contour chaise lounge
W	White strap
W	White mesh
W	White frame

Specify:

1. Pattern number
2. Strap color
3. Mesh color
4. Frame color

Ordering Information

Strap finishes:

White (suffix W)
Brown (suffix B)
Grey (suffix G)
Onyx (suffix O)
Sand (suffix S)
Bronze (suffix Z)

Mesh finishes:

White (suffix W)
Grey Tone (suffix T)
Onyx (suffix O)
Aluminum (suffix A)
Bronze (suffix Z)
Chestnut (suffix N)

Frame finishes:

Blue (suffix BLU)
Chestnut (suffix N)
Dark Bronze (suffix 14)
Green (suffix 007)
Light Bronze (suffix 13)
Lime Green (suffix LGR)
Onyx (suffix O)
Orange (suffix ORG)
Plum (suffix PLM)
Sky Blue (suffix 3)
Warm Bronze (suffix 16)
Warm Wood (suffix 12)
Weatherable Silver (suffix S)
White (suffix W)
Yellow (suffix YEL)

Maintenance:

See pages 28-29.

Upholstery/COM information:

Prices shown include fabric upholstery only. Contact your Knoll representative for colors.

Customer's Own Material is available pending approval. For approval requirements, processing instructions and ordering information, please see page 18

pattern no.		COM	
1966-41-(-)(-)(-)	\$3,183.	B	C
1966-41COV	920.		
1966-42-(-)(-)(-)	4,233.		
1966-42COV	796.		
1966-41P		852.	905.
1966-42P		667.	720.

Construction*Frame:*

Frame is aluminum castings and extrusions welded and glued together using a two-part epoxy. Finished in highly durable weather resistant polyester powder coat paint.

Seat:

Woven vinyl coated polyester mesh is sewn to pure vinyl straps using Teflon thread to form the seat and back. Stainless steel supports provides shape and is attached to the frame with stainless steel connectors.

Glides:

Clear butyrate plastic.

Approved KnollTextiles Grades/Fabrics**B**

Belize
Prairie
Vinyl





C

Baxter
Noble
Sinclair

*Check with your KnollTextiles
Representative for changes or additions.*

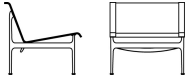
Richard Schultz

Swell® Seating Collection

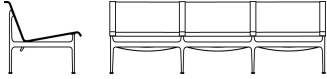
	description	seat h	w	d	h	textile fabric yds.	weight
<i>Designer(s):</i> Richard Schultz, 2007	SWELL-31 single seat club chair	16 1/2"	30"	31 1/2"	28"		22 lbs.
							
	SWELL-31COV single seat club chair cover						
							
	SWELL-32 two seat sofa	16 1/2"	58 1/2"	31 1/2"	28"		42 lbs.
							
	SWELL-32COV two seat sofa cover						
	SWELL-33 three seat sofa	16 1/2"	87"	31 1/2"	28"		63 lbs.
							
	SWELL-33COV three seat sofa cover						
	SWELL-20P 20" square pillow for SWELL-31, 32, 33					0.75	
	SWELL-31P Seat pad for SWELL-31, 32, 33					2.75	

Order Code

Example: **SWELL-33-B-W-W**

SWELL-33 Three seat sofa

B Brown strap

W White mesh

W White frame

Specify:

1. Pattern number
2. Strap color
3. Mesh color
4. Frame color

Ordering Information

Strap finishes:

White (suffix W)

Brown (suffix B)

Grey (suffix G)

Onyx (suffix O)

Sand (suffix S)

Bronze (suffix Z)

Mesh finishes:

White (suffix W)

Grey Tone (suffix T)

Onyx (suffix O)

Aluminum (suffix A)

Bronze (suffix Z)

Chestnut (suffix N)

Frame finishes:

Blue (suffix BLU)

Chestnut (suffix N)

Dark Bronze (suffix 14)

Green (suffix 007)

Light Bronze (suffix 13)

Lime Green (suffix LGR)

Onyx (suffix O)

Orange (suffix ORG)

Plum (suffix PLM)

Sky Blue (suffix 3)

Warm Bronze (suffix 16)

Warm Wood (suffix 12)

Weatherable Silver (suffix S)

White (suffix W)

Yellow (suffix YEL)

Maintenance:

See pages 28-29.

Upholstery/COM information:

Prices shown include fabric upholstery only. Contact your Knoll representative for colors.

Customer's Own Material is available pending approval. For approval requirements, processing instructions and ordering information, please see page 18

pattern no.		COM	
	-	B	C
SWELL-31-()-()-()	\$2,940.		
SWELL-31COV	450.		
SWELL-32-()-()-()	4,635.		
SWELL-32COV	752.		
SWELL-33-()-()-()	5,904.		
SWELL-33COV	947.		
SWELL-20P		235.	250.
SWELL-31P		916.	974.

Construction

Frame:

Frame is aluminum castings and extrusions welded and glued together using a two-part epoxy. Finished in highly durable weather resistant polyester powder coat paint.

Seat:

Woven vinyl coated polyester mesh is sewn to pure vinyl straps using Teflon thread to form the seat and back. Stainless steel supports provides shape and is attached to the frame with stainless steel connectors.

Glides:

Clear butyrate plastic.

Approved KnollTextiles Grades/Fabrics

B







Belize
Prairie
Vinyl

C

Baxter
Noble
Sinclair

Check with your KnollTextiles Representative for changes or additions.

Richard Schultz Topiary® Seating Collection

	description	seat h	arm h	w	d	h	textile fabric yds.	weight
Designer(s): Richard Schultz, 1996  	TOP-45 Topiary dining chair	18"	25"	26 1/2"	24"	34"		38 lbs.
								
	TDCP Chair pad for Topiary dining chair TOP-45						1.0	
	TOP-45COV Topiary dining chair cover							
	TOP-25 Topiary lounge chair	16"	21 1/2"	32"	32"	30 1/2"		45 lbs.
								
	TLCP Chair pad for Topiary lounge chair TOP-25						1.0	
	TOP-25COV Topiary lounge chair cover							
	TOP-455 Topiary bench	18"	25"	55"	26"	34 1/2"		84 lbs.
								
	TBP Chair pad for Topiary bench TOP-455						2.0	
	TOP-455COV Topiary bench cover							
	TOP-250 Topiary small ottoman/end table			20 3/4"	22"	15"		23 lbs.
								
	TSOP Seat pad for Topiary ottoman TOP-250						1.0	
	TOP-250COV Topiary small ottoman/end table cover							
	TOP-15 Topiary stacking chair	18 1/4"		22"	21"	30 1/4"		23 lbs.
								
	TSC Chair pad for Topiary stacking chair TOP-15						1.0	
	TSCOV Topiary stacking chair cover							
	TSCOV4 Topiary stacking chair cover for stack of four							

Order Code

<i>Example:</i>	TOP-455-1
TOP-455	Bench
1	Forest Green finish

Specify:

1. Pattern number
2. Finish color

Ordering Information

Finishes:

Blue (suffix BLU)
Chestnut (suffix N)
Choice White (suffix 6)
Daffodil Yellow (suffix 2)
Dark Bronze (suffix 14)
Forest Green (suffix 1)
Green (suffix 007)
Light Bronze (suffix 13)
Lime Green (suffix LGR)
Onyx (suffix O)
Orange (suffix ORG)
Plum (suffix PLM)

Sky Blue (suffix 3)
Terra Cotta (suffix 5)
Warm Bronze (suffix 16)
Warm Wood (suffix 12)
Weatherable Silver (suffix S)
White (suffix W)
Yellow (suffix YEL)

Maintenance:

See pages 28-29.

Upholstery/COM information:

Prices shown include fabric upholstery only. Contact your Knoll representative for colors.

Customer's Own Material is available pending approval. For approval requirements, processing instructions and ordering information, please see page 18

pattern no.		COM	
	-	B	C
TOP-45-()	\$1,832.		
TDCP		324.	346.
TOP-45COV	403.		
TOP-25-()	2,367.		
TLCP		346.	446.
TOP-25COV	432.		
TOP-455-()	3,509.		
TBP		675.	720.
TOP-455COV	781.		
TOP-250-()	1,559.		
TSOP		427.	449.
TOP-250COV	355.		
TOP-15-()	1,294.		
TSC		432.	453.
TSCOV	624.		
TSCOV4	745.		

Construction

Topiary frame:
 3/16" aluminum sheet stamped and formed. Stainless steel connectors and finished in highly durable weather resistant polyester powder coat paint. Clear butyrate plastic glides.

Stacking Chair:
 Seat and back is 3/16" aluminum sheet stamped and formed. Stainless steel connectors and finished in highly durable weather resistant polyester powder coat paint. Legs are 1" diameter stainless steel tubes attached to the seat using stainless steel connectors. Grey vinyl bumpers protect seats when stacked. Glides are natural color injection modded nylon.

Stacking:
 Topiary stacking chair stacks 15 high.

Approved KnollTextiles Grades/Fabrics

B
 Belize
 Prairie
 Vinyl

C
 Baxter
 Noble
 Sinclair

Check with your KnollTextiles Representative for changes or additions.

Richard Schultz

Fresh Air Dining Chair

Designer(s):
Richard Schultz, 2011



description	seat h	arm h	w	d	h	textile	
						fabric yds.	weight
FA-45TB Fresh Air dining chair	17 1/2"	25 1/2"	26 1/2"	24"	35"		18 lbs.
FA-45COV Fresh Air dining chair cover							
FA-45P Chair pad for Fresh Air FA-45TB						1.0	

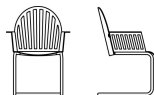

Order Code

<i>Example:</i>	FA-45TB-14
FA-45TB	Dining chair
14	Dark Bronze finish

Specify:

1. Pattern number
2. Finish color

Ordering Information

Finishes:
 Blue (suffix BLU)
 Chestnut (suffix N)
 Choice White (suffix 6)
 Daffodil Yellow (suffix 2)
 Dark Bronze (suffix 14)
 Forest Green (suffix 1)
 Green (suffix 007)
 Light Bronze (suffix 13)
 Lime Green (suffix LGR)
 Onyx (suffix O)
 Orange (suffix ORG)
 Plum (suffix PLM)
 Sky Blue (suffix 3)
 Terra Cotta (suffix 5)
 Warm Bronze (suffix 16)
 Warm Wood (suffix 12)
 Weatherable Silver (suffix S)
 White (suffix W)
 Yellow (suffix YEL)

Maintenance:
 See pages 28-29.

Upholstery/COM information:
 Prices shown include fabric upholstery only. Contact your Knoll representative for colors.

Customer's Own Material is available pending approval. For approval requirements, processing instructions and ordering information, please see page 18

Construction

Seat:
 3/16" aluminum sheet laser cut and formed. Two piece construction. Stainless steel connectors and finished in highly durable weather resistant polyester powder coat paint.

Base:
 1" diameter electropolished 304 stainless steel tube. Attached to seat using stainless steel screws and connectors.

Glides:
 Nylon glides.

pattern no.		COM	
FA-45TB-()	\$1,108.	B	C
FA-45COV	373.		
FA-45P		410.	431.

Approved KnollTextiles Grades/Fabrics

B
 Belize
 Prairie
 Vinyl

C
 Baxter
 Noble
 Sinclair

*Check with your KnollTextiles
 Representative for changes or additions.*



Shelton Mindel

Shelton Mindel Side Chair

Designer(s):
Peter Shelton and Lee Mindel,
2006

Award(s):
Good Design Award, 2006



description	seat h	arm h	w	d	h	textile fabric yds.	leather sq. ft.	weight	finish
SM8A Arm chair 	18"	23 1/2"	22"	23 1/2"	32"	1	18	19 lbs.	Other finishes
	18"	23 1/2"	22"	23 1/2"	32"	1	18	24 lbs.	Golden Oak, Maple
	18"	23 1/2"	22"	23 1/2"	32"	1	18	22 lbs.	Light Walnut
SM8A-U Arm chair, fully uph. 	18"	23 1/2"	22"	23 1/2"	32"	1.5	27	20 lbs.	Other finishes
	18"	23 1/2"	22"	23 1/2"	32"	1.5	27	25 lbs.	Golden Oak, Maple
	18"	23 1/2"	22"	23 1/2"	32"	1.5	27	23 lbs.	Light Walnut
SM8R seat basket replacement for SM8A and SM8A-U						1	18		

Order Code

<i>Example:</i>	SM8A-B312-K162/20
SM8A	Shelton Mindel side chair, seat upholstery only
B312	Bronzed Cherry
K162/20	Classic Boucle, Neutral

The Shelton Mindel side chair is part of a collection. Please refer to the SM lounge collections starting on page 276 and the SM table collection on page 406.

Specify:

1. Pattern number
2. Finish selection
3. Textile selection

Ordering Information

Oak with light lacquer finish:
Golden Oak (suffix GO)

Walnut with light lacquer finish:
Light Walnut (suffix LWT)

Maple:
Clear Maple (suffix KC)

Beech frame stains:
Bronzed Cherry (suffix B312A)
Burnt Walnut (suffix B313)
Ebonized (suffix BE)
Light Cherry (suffix B315)
Light Walnut (suffix B411)
Medium Cherry (suffix B319)
Medium Red Mahogany (suffix BR)
Medium Walnut (suffix B323)
Natural Beech (suffix BN)
Peacock Green Walnut (suffix B415)
Smoked Walnut (suffix B418)

Upholstery/COM information:
Prices shown include fabric or leather upholstery. Contact your Knoll representative for colors. Only approved KnollTextiles and Spinneybeck leathers may be ordered.

Customer's Own Material is available pending approval. For approval requirements, processing instructions and ordering information please see page 18.

Construction

Frame:
Available in Beech, Walnut and Oak hardwood with mortise and tenon construction.

Upholstered Seat:
1 3/4" thick seat filled with high density polyurethane foam, with elastic webbing suspension in a cross weave. Seat frame is constructed of 1" plywood.

Fully Upholstered:
Inside back upholstery is inset in frame. * indicates approved textiles and leathers.

Finish:
Satin catalyzed lacquer finish. Oak and Walnut versions have lower sheen.

Glides:
Chairs feature plastic glides.

Certified Wood:
Chairs manufactured using FSC certified hardwoods are available through Custom Product Development. Extended leadtime and upcharge apply.

KnollStudio wood finishes:
KnollStudio wood finishes complement a large variety of KnollStudio veneer and Knoll Office veneer finishes. To select correct complementary finish, please refer to KnollStudio Wood Finish Matrix on page 25. If no complementary standard finish is available, please refer to custom finish policy below.

Custom finishes:
Complementary finishes to any KnollStudio or Knoll Office wood finish are available at no upcharge. To complement non-Knoll wood veneer or lumber finishes, a one-time, non-negotiable net upcharge of \$600 applies. Re-orders are at no upcharge. Please contact your KnollStudio representative, dealer or Customer Service associate for complete custom finish information and Order Code. Minimum order quantity for any custom finish order: 4 chairs.

Cal 133 Fire Code:
The Shelton Mindel Side Chairs comply with the California Technical Bulletin 133 standard if upholstered in Cal 133 approved upholstery. Specify suffix -C at end of pattern number and suffix -133 at end of textile selection. Upcharge applies, see page 19.

Maintenance:
See pages 28-29.

Note:
The Shelton Mindel Side Chair is Greenguard certified.

pattern no.	grades	COM								COM				
	A	B	C	D	E	F	G	H	I	U	V	W	X	Y
SM8A-()	\$1,616.	\$1,643.	\$1,671.	\$1,701.	\$1,725.	\$1,741.	\$1,772.	\$1,828.	\$1,869.	\$2,004.	\$2,106.	\$2,311.	\$2,355.	\$2,406.
SM8A-(GO,KC)	1,939.	1,968.	1,995.	2,024.	2,049.	2,066.	2,095.	2,153.	2,195.	2,328.	2,431.	2,638.	2,680.	2,730.
SM8A-(LWT)	2,209.	2,238.	2,266.	2,296.	2,321.	2,337.	2,366.	2,424.	2,465.	2,600.	2,700.	2,907.	2,949.	3,001.
SM8A-U-()	1,946.	1,986.	2,028.	2,073.	2,108.	2,134.	2,181.	2,266.	2,327.	2,530.	2,680.	2,990.	3,055.	3,130.
SM8A-U-(GO,KC)	2,209.	2,252.	2,291.	2,337.	2,372.	2,399.	2,445.	2,531.	2,590.	2,793.	2,944.	3,255.	3,320.	3,395.
SM8A-U-(LWT)	2,503.	2,544.	2,583.	2,629.	2,665.	2,692.	2,737.	2,823.	2,885.	3,084.	3,236.	3,547.	3,612.	3,686.
SM8R-()	437.	461.	485.	509.	531.	547.	573.	623.	659.	993.	1,084.	1,264.	1,300.	1,346.

Approved KnollTextiles Grades/Fabrics

A	Alignment † Beacon Bocce * Cat's Cradle * Chance * Common Ground Commuter Cloth * † Delite * Dristi Hourglass * Mariner * Monarch † Prep * † Presto * † Soliloquy * Sonnet * Stacks Trophy	B	continued Night Life Petal Pusher * Pop Prairie * Prim * Radiance * Ransom * Ricochet † Roam * Rush Hour * Soiree * Spark † Spinoff Nuance Spree * Starry Night † * Summit * Sutton * Synth Tabloid * Utmost * Venue * Versa Vinyl Westwood * Wide Angle * † Zephyr Zipline *	C	continued Hudson * Hula Hoop Kaleidoscope CR Lagos * Legend CR * Lore CR * Magnolia Metro Milestone * Noble * Palisade * Panache CR Posh * Quark * Regard CR Roundtrip * Sahara Sandpiper * Sequin CR Sinclair * Smart * Spectator * Spot On * Star Struck Stepping Stones Swing * Tara * Tight Rope * Tilden Tower Grid * Transition † Treble CR Vibe *	D	continued Masquerade Menagerie * Origins Satellite Satin Chisel Theory Woodland * Zoom Highland * Ikat Square Ikat Stripe Kampala * Katazome * Kimono Luberon Mamba Marquee * Meroe Sherman * Shima * Tryst * Whip * Atelier * Biscayne Calais Cotton Velvet * Coco Cornaro * Eclipse * Glider Intrigue * Liberty * Mod Plaid * Rivington	E	continued Soon * Topography Totem * Tweed Frieze Arabella * Arber Djenne * Hampshire Haze Kamani * Kinabalu * Kingston * Melange * Metallic Gloss * Sablon * Serendipity * Spencer Straie Stripe * Ultrasuede * † Utrillo Arno * Bavaria * Constance * Firefly * Gezelle * Magritte * Rosemond	F	continued Aswan * Byron * Canaan * Cato * Cummings * Diamond Days Digi Velvet Dynamic * Gates * Maremma † Ita * Jaipur Knoll Velvet * North Island * Olema Piper Ravello * Rutledge Sandis Tudor * Vermeer * Walker * Worth Zimba	G	continued Arabella * Arber Djenne * Hampshire Haze Kamani * Kinabalu * Kingston * Melange * Metallic Gloss * Sablon * Serendipity * Spencer Straie Stripe * Ultrasuede * † Utrillo Arno * Bavaria * Constance * Firefly * Gezelle * Magritte * Rosemond	H	continued Aswan * Byron * Canaan * Cato * Cummings * Diamond Days Digi Velvet Dynamic * Gates * Maremma † Ita * Jaipur Knoll Velvet * North Island * Olema Piper Ravello * Rutledge Sandis Tudor * Vermeer * Walker * Worth Zimba	I	continued Aswan * Byron * Canaan * Cato * Cummings * Diamond Days Digi Velvet Dynamic * Gates * Maremma † Ita * Jaipur Knoll Velvet * North Island * Olema Piper Ravello * Rutledge Sandis Tudor * Vermeer * Walker * Worth Zimba	U	Vicenza * † Volo * † Acqua * † Andes * † Embossed Tipped * † España * † Maremma † Velluto Pelle * † Alaska * † Amazon * † Antique * † Arizona * † Forte * † Lucente Sabrina * †	V	Vicenza * † Volo * † Acqua * † Andes * † Embossed Tipped * † España * † Maremma † Velluto Pelle * † Alaska * † Amazon * † Antique * † Arizona * † Forte * † Lucente Sabrina * †	W	Vicenza * † Volo * † Acqua * † Andes * † Embossed Tipped * † España * † Maremma † Velluto Pelle * † Alaska * † Amazon * † Antique * † Arizona * † Forte * † Lucente Sabrina * †	X	Ducale * † Ducale Velour * † Capri * † Cervo * Copenhagen * † Cordovan * † Distressed * † Lucca Marissa * † Prima * † Riva * † Salon * † Torello	Y	Ducale * † Ducale Velour * † Capri * † Cervo * Copenhagen * † Cordovan * † Distressed * † Lucca Marissa * † Prima * † Riva * † Salon * † Torello
----------	--	----------	--	----------	---	----------	---	----------	---	----------	---	----------	--	----------	---	----------	---	----------	---	----------	---	----------	---	----------	--	----------	--

Spinneybeck Leather

U	Vicenza * † Volo * † Acqua * † Andes * † Embossed Tipped * † España * † Maremma † Velluto Pelle * † Alaska * † Amazon * † Antique * † Arizona * † Forte * † Lucente Sabrina * †	V	Vicenza * † Volo * † Acqua * † Andes * † Embossed Tipped * † España * † Maremma † Velluto Pelle * † Alaska * † Amazon * † Antique * † Arizona * † Forte * † Lucente Sabrina * †	W	Vicenza * † Volo * † Acqua * † Andes * † Embossed Tipped * † España * † Maremma † Velluto Pelle * † Alaska * † Amazon * † Antique * † Arizona * † Forte * † Lucente Sabrina * †	X	Ducale * † Ducale Velour * † Capri * † Cervo * Copenhagen * † Cordovan * † Distressed * † Lucca Marissa * † Prima * † Riva * † Salon * † Torello	Y	Ducale * † Ducale Velour * † Capri * † Cervo * Copenhagen * † Cordovan * † Distressed * † Lucca Marissa * † Prima * † Riva * † Salon * † Torello
----------	---	----------	---	----------	---	----------	--	----------	--

* Approved for fully upholstered versions.
† Approved for Cal 133 upholstery.

Check with your KnollTextiles or Spinneybeck Representative for changes or additions.

Shelton Mindel

SM1 Lounge Collection

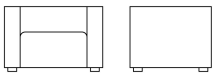
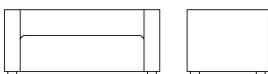
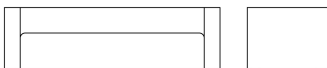
	description	seat h	arm h	w	d	h	textile fabric yds.	leather sq. ft.	weight
<p><i>Designer(s):</i> Peter Shelton and Lee Mindel, 2006</p> 	SM1-1 SM1 Lounge chair 	15 1/2"	25 1/2"	39"	32 1/4"	25 1/2"	6.5	80	83 lbs.
	SM1-2 SM1 Settee 	15 1/2"	25 1/2"	61 1/2"	32 1/4"	25 1/2"	9.0	120	96 lbs.
	SM1-3 SM1 Sofa 	15 1/2"	25 1/2"	85 1/2"	32 1/4"	25 1/2"	11.3	148	116 lbs.

Order Code

Example: **SM1-1-AOC-K349/1**

SM1-1 SM1 Lounge Chair

AOC Clear Oak legs

K349/1 Alignment, Sand

The SM1 lounge collection is part of a collection. Please refer to the Shelton Mindel side chair on page 274, SM2 lounge collection on page 278 and the SM table collection on page 406.

Specify:

1. Pattern number
2. Leg finish
3. Textile selection

Ordering Information

Leg finishes:

Clear Oak (suffix AOC)
Ebonized (suffix AE)
Polished Stainless Steel (suffix S)

Upholstery/COM information:

Prices shown include fabric or leather upholstery. Contact your Knoll representative for colors. Only approved KnollTextiles and Spinneybeck leathers may be ordered.

Customer's Own Material is available pending approval. For approval requirements, processing instructions and ordering information please see page 18.

Cal 133 Fire Code#:

The SM1 Lounge Collection complies with the California Technical Bulletin 133 standard if upholstered in Cal 133 approved upholstery. Specify suffix -C at end of pattern number and suffix -133 at end of textile selection. Upcharge applies, see page 19.

Maintenance:

See pages 28-29.

Construction

Frame:

Constructed in multi ply plywood with sinuous spring seat suspension and elastic webbing back suspension.

Upholstery:

Seat and back cushions are continuous on all models.

Cushion fill:

Arm, seat and back cushions in variable density foam with Dacron wrap.

Stitching:

Double-needled topstitching on leather upholstery. Double-needled topstitching on thin solid textiles, single-blind stitching on heavily ribbed fabrics and multicolor prints.

Legs:

Round legs in Ash hardwood stained in Clear Oak, Ebonized or Polished Stainless Steel finish.

pattern no.	grades	COM								COL				
	A	B	C	D	E	F	G	H	I	U	V	W	X	Y
SM1-1-(-)(-)	\$4,154.	\$4,338.	\$4,513.	\$4,706.	\$4,865.	\$4,980.	\$5,173.	\$5,542.	\$5,813.	\$6,659.	\$7,223.	\$8,374.	\$8,614.	\$8,892.
SM1-2-(-)(-)	6,203.	6,458.	6,702.	6,970.	7,188.	7,347.	7,614.	8,127.	8,502.	9,882.	10,731.	12,457.	12,814.	13,231.
SM1-3-(-)(-)	7,326.	7,647.	7,953.	8,289.	8,563.	8,763.	9,099.	9,740.	10,213.	11,822.	12,870.	14,995.	15,437.	15,953.

Approved KnollTextiles Grades/Fabrics

A	Alignment ‡ Beacon Bocce Cat's Cradle Chance Common Ground Commuter Cloth ‡ Cotton Duck Delite Dristi Heavy Metal Hourglass Mariner Monarch ‡ Prep ‡ Presto ‡ Sonnet Stacks Trophy	B	Argyle Bank Shot Belize Betwixt ‡ Bistro ‡ Cameo Chroma Chronicle Ferry Gala II Holbrook Journey Keaton Knoll Felt Knoll Hopsack Ludlow Nonchalant CR ‡	E continued	Paradigm Petal Pusher Pogo Pop Prairie Prim Radiance Ransom Ricochet ‡ Roam Rush Hour Soiree Spark ‡ Spinoff Nuance Spree Starry Night ‡ Summit Sutton Synth Tabloid Venue Versa Vinyl Westwood Zephyr Zipline	C continued	Roundtrip Sahara Sandpiper Sequin CR Spot On Star Struck Swing Tight Rope Tilden Tower Grid Transition ‡ Vibe	D	Coterie Eclat Weave * Island Menagerie Origins Satellite Satin Chisel Tara Theory Woodland	E	Highland Ikat Square Ikat Stripe Kampala Katazome Luberon * Mamba Marquee Meroe Tryst Whip	F	Atelier Biscayne Calais Cotton Velvet * Coco Cornaro Glider Intrigue Liberty Mod Plaid Rivington Soon Topography Totem Tweed Frieze *	G	Djenne Hampshire Haze * Kinabalu Kingston Melange Serendipity Spencer Ultrasuede ‡	H	Arno Constance Firefly Gezelle Magritte Rosemond	I	Cato Diamond Days Digi Velvet Dynamic Gates Knoll Velvet * Olema Piper Ravello Rutledge Sandis Tudor Vermeer Walker Worth Zimba
----------	--	----------	---	--------------------	---	--------------------	--	----------	---	----------	--	----------	---	----------	--	----------	---	----------	--

Spinneybeck Leather

U	Vicenza ‡ Volo ‡	X	Ducale ‡ Ducale Velour ‡
V	Acqua ‡ Andes ‡ Embossed Tipped España ‡ Velluto Pelle ‡	Y	Capri ‡ Cervo Copenhagen ‡ Cordovan ‡ Distressed ‡ Marissa ‡ Prima ‡ Riva ‡ Saddle ‡
W	Alaska ‡ Amazon ‡ Antique ‡ Arizona ‡ Derby ‡ Forte ‡ Lucente Sabrina ‡		

‡ Approved for Cal 133 upholstery.
* Indicates fabrics without topstitching.

Check with your KnollTextiles or Spinneybeck Representative for additions or changes.

Shelton Mindel

SM2 Lounge Collection

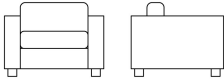
	description	seat h	arm h	w	d	h	type	textile	leather	weight
								fabric yds.	sq ft	
<p><i>Designer(s):</i> Peter Shelton and Lee Mindel, 2006</p> 	<p>SM2-1 SM2 Lounge chair, same upholstery, frame and cushions</p> 	17 3/4"	23 3/4"	39 1/4"	36 1/2"	29"		8.3	124	56 lbs.
	<p>SM2-1 SM2 Lounge chair, combination upholstery, frame and cushions</p>	17 3/4"		39 1/4"	36 1/2"	29"	frame uph.	5	76	
							upchg, cushions	4.25	56	

Order Code

<i>Example:</i>	SM2-2-S-K349/1
SM2-2	SM2 Lounge Collection, settee
S	Stainless Steel legs
K349/1	Alignment, Sand
<i>Example:</i>	SM2S-2-AE-VOBLK-K349/1
SM2-2	SM2 Lounge Collection, settee
AE	Ebonized legs
VOBLK	Surround in Volo, Black
K349/1	Cushions in Alignment, Sand

The SM2 lounge collection is part of a collection. Please refer to the Shelton Mindel side chair on page 274, SM1 lounge collection on page 276 and SM table collection on page 406.

Specify:

1. Pattern number
2. Leg finish
3. Textile selection

Specify with split upholstery:

1. Pattern number
2. Leg finish
3. Textile selection, Surround
4. Textile selection, Cushions

Ordering Information

Leg finishes:
Clear Oak (suffix AOC)
Ebonized (suffix AE)
Polished Stainless Steel (suffix S)

Upholstery/ COM information:
Prices shown includes fabric or leather upholstery. Contact your Knoll representative for colors. Only approved KnollTextiles and Spinneybeck leathers may be ordered.

Customer's Own Material is available pending approval. For approval requirements, processing instructions and ordering information please see page 18.

Cal 133 Fire Code #:

The SM2 Lounge Collection complies with the California Technical Bulletin 133 standard if upholstered in Cal 133 approved upholstery. Specify suffix -C at end of pattern number and suffix -133 at end of textile selection. Upcharge applies, see page 19.

Maintenance:

See pages 28-29.

Construction

Frame:
Constructed in 3/8" multi ply plywood with sinuous spring seat suspension and matrix back suspension.

Upholstery:
One seat and back cushion for the Lounge chair, two seat and back cushions for the Settee and three seat and back cushions for the Sofa. For units with combination upholstery, add list price of surround in appropriate grade with the list price of cushions to obtain total list price for item.

Cushion fill:

Arm, seat and back cushions in variable density foams with Dacron wrap. The seat and back cushions are filled with memory foam.

Stitching:

Double needle top stitching on arms and back. Single needle top stitching on seat and back cushions in textile, double needle stitching for leather.

Legs:

Round legs in Ash substrate with a Clear Oak, Ebonized or Polished Stainless Steel finish.

pattern no.	grades A	COM B	C	D	E	F	G	H	I	COL U	V	W	X	Y
SM2S-1-(-)(-)	\$5,353.	\$5,591.	\$5,813.	\$6,062.	\$6,262.	\$6,409.	\$6,657.	\$7,128.	\$7,474.	\$9,123.	\$9,997.	\$11,797.	\$12,153.	\$12,582.
SM2S-1-(-)(-)(-)	4,285.	4,457.	4,617.	4,798.	4,942.	5,049.	5,226.	5,567.	5,821.	6,296.	6,834.	7,927.	8,156.	8,419.
upchg, cushions	1,577.	1,697.	1,812.	1,939.	2,041.	2,118.	2,243.	2,485.	2,663.	3,069.	3,464.	4,271.	4,437.	4,632.

Approved KnollTextiles Grades/Fabrics

A Alignment ‡ Beacon Boce Cat's Cradle Chance Common Ground Commuter Cloth ‡ Cotton Duck Delite Dristi Heavy Metal Hourglass Mariner Monarch ‡ Prep ‡ Presto ‡ Sonnet Stacks Trophy	B Abacus ‡ Argyle Bank Shot Belize Betwixt ‡ Bistro ‡ Cameo Chroma Chronicle Digit Ferry Holbrook Gala II Grandview Journey Keaton Knoll Felt	C Atlas Autobahn Axiom Biota ‡ Cairo Circa Classic Boucle Dahlia CR Decade Durand Earthwork ‡	E continued Knoll Hopsack Ludlow Night Life Nonchalant CR ‡ Paradigm Petal Pusher Pogo Pop Prairie Prim Radiance Ransom Ricochet ‡ Roam Rush Hour Soiree Spark ‡ Spinoff Nuance Spree Starry Night ‡ Summit Sutton Synth Tabloid Venue Versa Vinyl Westwood Zephyr Zipline	C continued Enmesh ‡ Entourage Fibra Greenwich Hudson Hula Hoop Kaleidoscope CR Kora CR Lagos Metro Milestone Moto CR Palisade Panache CR * Roundtrip Sahara Sandpiper Sequin CR Spot On Star Struck Stepping Stones Swing Tight Rope Tilden Tower Grid Transition ‡ Vibe Zari CR	D continued Menagerie Origins Satellite Satin Chisel Tara Theory Woodland E Highland Ikat Square Ikat Stripe Kampala Katazome Luberon * Mamba Marquee Shima Meroe Tryst Whip F Atelier Biscayne Calais Cotton Velvet * Coco Cornaro Eclipse Fiori Glider Icon * Intrigue Liberty Mod Plaid Rivington	F continued Soon Topography Totem Tweed Frieze * G Djenne Gezelle Hampshire Haze * Kinabalu Kingston Melange Magritte Serendipity Spencer Ultrasuede ‡	H Arno Constance Firefly Rosemond I Cato * Diamond Days Digi Velvet Dynamic Gates Knoll Velvet * Olema Piper Ravello Rutledge Sandis Tudor Vermeer Walker Worth Zimba	U Vicenza ‡ Volo ‡ V Acqua ‡ Andes ‡ Embossed Tipped España ‡ Velluto Pelle ‡ W Alaska ‡ Amazon ‡ Antique ‡ Arizona ‡ Derby ‡ Forte ‡ Lucente Sabrina ‡	X Ducale ‡ Ducale Velour ‡ Y Capri ‡ Cervo Copenhagen ‡ Cordovan ‡ Distressed ‡ Marissa ‡ Prima ‡ Riva ‡ Saddle ‡
---	---	---	---	--	--	--	--	---	---

Spinneybeck Leather

U Vicenza ‡ Volo ‡	X Ducale ‡ Ducale Velour ‡
V Acqua ‡ Andes ‡ Embossed Tipped España ‡ Velluto Pelle ‡	Y Capri ‡ Cervo Copenhagen ‡ Cordovan ‡ Distressed ‡ Marissa ‡ Prima ‡ Riva ‡ Saddle ‡
W Alaska ‡ Amazon ‡ Antique ‡ Arizona ‡ Derby ‡ Forte ‡ Lucente Sabrina ‡	

‡ Approved for Cal 133 upholstery.
* Indicates fabrics without topstitching.

Check with your KnollTextiles or Spinneybeck Representative for additions or changes.

Shelton Mindel

SM2 Lounge Collection

Designer(s):
Peter Shelton and Lee Mindel,
2006



description	seat h	arm h	w	d	height	type	textile fabric yds.	leather sq ft	weight
SM2-2 SM2 Settee, same upholstery, frame and cushions	17 3/4"	23 3/4"	66 1/2"	36 1/2"	29"		13.25	168	77 lbs.
SM2-2 SM2 Settee, combination upholstery, frame and cushions	17 3/4"		66 1/2"	36 1/2"	29"	frame uph.	7.5	104	
						upchg, cushions	7.5	80	
SM2-3 SM2 Sofa, same upholstery, frame and cushions	17 3/4"	23 3/4"	93 1/2"	36 1/2"	29"		19.5	208	108 lbs.
SM2-3 SM2 Sofa, combination upholstery, frame and cushions	17 3/4"		93 1/2"	36 1/2"	29"	frame uph.	9.5	128	
						upchg, cushions	11.25	104	

Order Code

<i>Example:</i>	SM2-2-S-K349/1
SM2-2	SM2 Lounge Collection, settee
S	Stainless Steel legs
K349/1	Alignment, Sand
<i>Example:</i>	SM2S-2-AE-VOBLK-K349/1
SM2-2	SM2 Lounge Collection, settee
AE	Ebonized legs
VOBLK	Surround in Volo, Black
K349/1	Cushions in Alignment, Sand

The SM2 lounge collection is part of a collection. Please refer to the Shelton Mindel side chair on page 274, SM1 lounge collection on page 276 and SM table collection on page 406.

Specify:

1. Pattern number
2. Leg finish
3. Textile selection

Specify with split upholstery:

1. Pattern number
2. Leg finish
3. Textile selection, Surround
4. Textile selection, Cushions

Ordering Information

Leg finishes:
Clear Oak (suffix AOC)
Ebonized (suffix AE)
Polished Stainless Steel (suffix S)

Upholstery/ COM information:
Prices shown includes fabric or leather upholstery. Contact your Knoll representative for colors. Only approved KnollTextiles and Spinneybeck leathers may be ordered.

Customer's Own Material is available pending approval. For approval requirements, processing instructions and ordering information please see page 18.

Cal 133 Fire Code:

The SM2 Lounge Collection complies with the California Technical Bulletin 133 standard if upholstered in Cal 133 approved upholstery. Specify suffix -C at end of pattern number and suffix -133 at end of textile selection. Upcharge applies, see page 19.

Maintenance:

See pages 28-29.

Construction

Frame:
Constructed in 3/8" multi ply plywood with sinuous spring seat suspension and matrix back suspension.

Upholstery:
One seat and back cushion for the Lounge chair, two seat and back cushions for the Settee and three seat and back cushions for the Sofa. For units with combination upholstery, add list price of surround in appropriate grade with the list price of cushions to obtain total list price for item.

Cushion fill:

Arm, seat and back cushions in variable density foams with Dacron wrap. The seat and back cushions are filled with memory foam.

Stitching:

Double needle top stitching on arms and back. Single needle top stitching on seat and back cushions in textile, double needle stitching for leather.

Legs:

Round legs in Ash substrate with a Clear Oak, Ebonized or Polished Stainless Steel finish.

pattern no.	grade A	COM B	C	D	E	F	G	H	I	COL U	V	W	X	Y
SM2S-2-(-)(-)	\$8,018.	\$8,393.	\$8,751.	\$9,146.	\$9,468.	\$9,700.	\$10,097.	\$10,847.	\$11,402.	\$12,969.	\$14,155.	\$16,571.	\$17,073.	\$17,656.
SM2S-2-(-)(-)(-)	6,289.	6,516.	6,732.	6,971.	7,165.	7,306.	7,543.	7,998.	8,334.	9,054.	9,789.	11,284.	11,593.	11,958.
upchg, cushionsS	2,354.	2,566.	2,768.	2,991.	3,174.	3,305.	3,530.	3,955.	4,271.	4,409.	4,973.	6,123.	6,363.	6,642.
SM2-3-(-)(-)	10,375.	10,929.	11,456.	12,037.	12,511.	12,853.	13,436.	14,543.	15,359.	16,381.	17,851.	20,840.	21,463.	22,185.
SM2S-3-(-)(-)(-)	8,116.	8,443.	8,753.	9,095.	9,376.	9,578.	9,921.	10,573.	11,056.	11,432.	12,338.	14,177.	14,559.	15,004.
upchg, cushionsSO	3,092.	3,410.	3,715.	4,052.	4,324.	4,522.	4,855.	5,494.	5,967.	5,685.	6,420.	7,915.	8,226.	8,588.

Approved KnollTextiles Grades/Fabrics

A Alignment ‡ Beacon Bocce Cat's Cradle Chance Common Ground Commuter Cloth ‡ Cotton Duck Delite Dristi Heavy Metal Hourglass Mariner Monarch ‡ Prep ‡ Presto ‡ Sonnet Stacks Trophy	E continued Knoll Hopsack Ludlow Night Life Nonchalant CR ‡ Paradigm Petal Pusher Pogo Pop Prairie Prim Radiance Ransom Ricochet ‡ Roam Rush Hour Soiree Spark ‡ Spinoff Nuance Spree Starry Night ‡ Summit Sutton Synth Tabloid Venue Versa Vinyl Westwood Zephyr Zipline	C continued Enmesh ‡ Entourage Fibra Greenwich Hudson Hula Hoop Kaleidoscope CR Kora CR Lagos Metro Milestone Moto CR Palisade Panache CR * Roundtrip Sahara Sandpiper Sequin CR Spot On Star Struck Stepping Stones Swing Tight Rope Tilden Tower Grid Transition ‡ Vibe Zari CR	D continued Menagerie Origins Satellite Satin Chisel Tara Theory Woodland	E Highland Ikat Square Ikat Stripe Kampala Katazome Luberon * Mamba Marquee Shima Meroe Tryst Whip	F Atelier Biscayne Calais Cotton Velvet * Coco Cornaro Eclipse Fiori Glider Icon * Intrigue Liberty Mod Plaid Rivington
--	---	--	---	---	--

Spinneybeck Leather

U Vicenza ‡ Volo ‡	V Acqua ‡ Andes ‡ Embossed Tipped España ‡ Velluto Pelle ‡	W Alaska ‡ Amazon ‡ Antique ‡ Arizona ‡ Derby ‡ Forte ‡ Lucente Sabrina ‡	X Ducale ‡ Ducale Velour ‡	Y Capri ‡ Cervo Copenhagen ‡ Cordovan ‡ Distressed ‡ Marissa ‡ Prima ‡ Riva ‡ Saddle ‡
---------------------------------	--	--	---	--

‡ Approved for Cal 133 upholstery.
* Indicates fabrics without topstitching.

Check with your KnollTextiles or Spinneybeck Representative for additions or changes.

Stamberg Aferiat Salsa® Lounge Seating

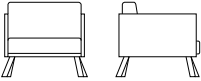
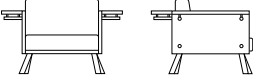
	description	seat h	arm h	w	d	h	textile fabric yds.	req. leather sq. ft.	weight
<p><i>Designer(s):</i> Peter Stamberg and Paul Aferiat, 1994</p> <p><i>Award(s):</i> Honorable Mention, ID Design Review, 1995</p> 	<p>66S1-Y Lounge chair without grommets</p> 	16 3/4"	24 3/8"	31"	30"	29"	2.8	50	87 lbs.
	<p>66S1-M Lounge chair with grommets for shelves</p> 	16 3/4"	24 3/8"	47"	30"	29"	2.8	50	89 lbs.

Order Code

Example: **66S1-M-TF-B-K787/10**
(2)66SH-A-TF-B

66S1	Lounge chair
M	Grommet option
TF	Tutti Frutti leg finishes
B	Natural Beech frame
K787/10	Calais Cotton Velvet, Lipstick
(2)66SH-A	Two arm shelves
TF	Tutti Frutti bracket finishes
B	Natural Beech shelf finish

Specify:

1. Pattern number
2. Grommet option
3. Leg finish selection
4. Wood frame finish
5. Textile selection
6. Arm shelf option pattern number
7. Shelf bracket finish
8. Shelf finish

Ordering Information

Grommet option:
Grommets (suffix M)
No grommets: (suffix Y)

Leg and shelf bracket finishes:
Real Red (suffix RR)
Nasturtium Orange (suffix NO)
Daffodil Yellow (suffix DY)
Spring Green (suffix SG)
Cornflower Blue (suffix CB)
Wisteria Violet (suffix WV)
Tutti Frutti, mix of all above colors (suffix TF)
Copper (suffix CO)
Tungsten (suffix TU)
Dark Metallic Grey (suffix V)

Custom mix of colors:
Add 5% to list price and provide descriptive drawing.

Wood frame and shelf finishes:
Maple (suffix K)
Natural Beech (suffix B)
Medium Red Mahogany (suffix Z)
Warm Brown Walnut (suffix J)
Ebonized Walnut (suffix D)

Side cushion:
Specify side cushions separately. Narrow side cushion recommended for lounge chairs.

Upholstery/COM information:
Prices shown include fabric or leather upholstery. Contact your Knoll representative for colors. Only approved Knoll Textiles and Spinneybeck leathers may be ordered.

Customer's Own Material is available pending approval. For approval requirements, processing instructions and ordering information please see page 18.

Shelf specification note:
Additional shelf options are listed on page 288. Shelves are shipped separately, and installed on site.

The Salsa Lounge Seating Collection is Greenguard certified.

Glides:
Plastic glides.

Maintenance:
See pages 28-29.

Construction

Grommets, legs & shelf supports:
1 1/8"D x 8 1/4"H legs are cold-rolled 14 gauge seamless steel tubing. 1 1/4"D shelf supports are aluminum alloy. Copper and tungsten finishes are powder-coated finishes. Grommets are 1 1/4" aluminum castings with tungsten powder-coat finish on side and back. 12 grommets per lounge chair; 14 grommets per settee; 16 grommets per sofa. Shelf supports are nickel-plated steel.

Wood frame and shelves:
Natural veneer over 1 1/4" thick solid fiberboard core.

Upholstery:
Highly resilient Dymetrol seat suspension over black plywood frame attached to black 12-gauge steel frame. Welting detail with both leather and textile upholstery.

Cushion fill:
5" thick polycore with a soft, double-wrapped quilted dacron wrap for a softer sit. Cushion displays moderate crowning.

pattern no.	grades													
	A	B	C	D	E	F	G	H	I	U	V	W	X	Y
66S1-Y	\$3,927.	\$4,044.	\$4,161.	\$4,249.	\$4,323.	\$4,389.	\$4,464.	\$4,648.	\$4,992.	\$5,833.	\$6,254.	\$7,105.	\$7,281.	\$7,490.
66S1-M	4,078.	4,197.	4,313.	4,394.	4,471.	4,536.	4,612.	4,800.	5,141.	5,982.	6,401.	7,256.	7,432.	7,637.

Approved KnollTextiles Grades/Fabrics

A	Alignment Beacon Bocce Cat's Cradle Chance Common Ground Commuter Cloth Cotton Duck Delite Dristi Hourglass Mariner Monarch Prep Presto Soliloquy Sonnet Stacks Trophy	B continued Digit Digital Tape Dovetail Ferry Gala II Grande Grandview Holbrook Journey Keaton Knoll Felt Knoll Hopsack Ludlow Lyric Mini Stitch Night Life Nonchalant CR Paradigm Petal Pusher Pogo Pop Prairie Prim Prompt Radiance Ransom Ricochet Roam Rush Hour Soiree Spark Spinoff Nuance Spree Starry Night Summit Sutton Synth Tabloid Venue Versa Vinyl Westwood Wide Angle Zephyr Zipline	C Autobahn Axiom Baxter Biota Charm Circa Classic Boucle Dahlia CR Dune Durand Earthwork Echo Empire Stripe Enmesh Entourage Fable CR Fibra Greenwich Hudson Hula Hoop Kaleidoscope CR Kora CR Lagos Legend CR Lore CR Metro Milestone Moto CR Noble	C continued Palisade Panache CR Quark Regard CR Roundtrip Sandpiper Sequin CR Sinclair Smart Spectator Spot On Star Struck Stepping Stones Swing Tilden Tower Grid Transition Treble CR Zari CR	D Compass CR Coterie Eclat Weave Hologram In The Loop Island Masquerade Menagerie Origins Satellite Satin Chisel Tara Theory Woodland Zoom
E	Highland Ikat Square Quark Kampala Katazome Kimono Luberon Mamba Marquee Meroe Sherman Shima Tryst Whip	F Atelier Biscayne Calais Cotton Velvet Cornaro Eclipse Glider Icon Intrigue Liberty Mod Plaid Rivington Topography Totem	G continued Haze Kamani Kinbalu Kingston Melange Metallic Gloss Sablon Serendipity Spencer Straie Stripe Ultrasede Utrillo	H Arno Bavaria Constance Firefly Gezelle Magritte Rosemond	I Aswan Byron Canaan Cato Cummings Diamond Days Digi Velvet Dynamic Gates Ita Jaipur Knoll Velvet North Island Olema Piper Ravello Rutledge Tudor Vermeer Walker Worth Zimba

Spinneybeck Leather

U Vicenza Volo	V Acqua Andes Embossed Tipped España Hand Tipped Velluto Pelle	W continued Forte Lucente Sabrina	X Ducale Ducale Velour	Y Capri Cervo Copenhagen Cordovan Distressed Lucca Marissa Portofino Prima Riva Torello
-----------------------------	---	---	-------------------------------------	---

Check with your KnollTextiles or Spinneybeck Representative for changes or additions.

Stamberg Aferiat Salsa® Lounge Seating

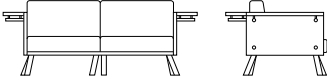
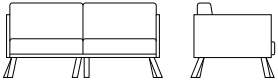
	description	seat h	arm h	w	d	h	textile fabric yds.	req. leather sq. ft.	weight
<p><i>Designer(s):</i> Peter Stamberg and Paul Aferiat, 1994</p> <p><i>Award(s):</i> Honorable Mention, ID Design Review, 1995</p> 	<p>66S2-M Settee with grommets for shelves</p> 	16 ^{3/4} "	24 ^{3/8} "	76"	30"	29"	5.5	100	138 lbs.
	<p>66S2-Y Settee without grommets</p> 	16 ^{3/4} "	24 ^{3/8} "	60"	30"	29"	5.5	100	136 lbs.

Order Code

Example: **66S1-M-TF-B-K787/10**
(2)66SH-A-TF-B

66S1	Lounge chair
M	Grommet option
TF	Tutti Frutti leg finishes
B	Natural Beech frame
K787/10	Calais Cotton Velvet, Lipstick
(2)66SH-A	Two arm shelves
TF	Tutti Frutti bracket finishes
B	Natural Beech shelf finish

Specify:

1. Pattern number
2. Grommet option
3. Leg finish selection
4. Wood frame finish
5. Textile selection
6. Arm shelf option pattern number
7. Shelf bracket finish
8. Shelf finish

Ordering Information

Grommet option:
Grommets (suffix M)
No grommets: (suffix Y)

Leg and shelf bracket finishes:
Real Red (suffix RR)
Nasturtium Orange (suffix NO)
Daffodil Yellow (suffix DY)
Spring Green (suffix SG)
Cornflower Blue (suffix CB)
Wisteria Violet (suffix WV)
Tutti Frutti, mix of all above colors (suffix TF)
Copper (suffix CO)
Tungsten (suffix TU)
Dark Metallic Grey (suffix V)

Custom mix of colors:
Add 5% to list price and provide descriptive drawing.

Wood frame and shelf finishes:
Maple (suffix K)
Natural Beech (suffix B)
Medium Red Mahogany (suffix Z)
Warm Brown Walnut (suffix J)
Ebonized Walnut (suffix D)

Side cushion:
Specify side cushions separately. Narrow side cushion recommended for lounge chairs.

Upholstery/COM information:
Prices shown include fabric or leather upholstery. Contact your Knoll representative for colors. Only approved Knoll Textiles and Spinneybeck leathers may be ordered.

Customer's Own Material is available pending approval. For approval requirements, processing instructions and ordering information please see page 18.

Shelf specification note:
Additional shelf options are listed on page 288. Shelves are shipped separately, and installed on site.

The Salsa Lounge Seating Collection is Greenguard certified.

Glides:
Plastic glides.

Maintenance:
See pages 28-29.

Construction

Grommets, legs & shelf supports:
1 1/8"D x 8 1/4"H legs are cold-rolled 14 gauge seamless steel tubing. 1 1/4"D shelf supports are aluminum alloy. Copper and tungsten finishes are powder-coated finishes. Grommets are 1 1/4" aluminum castings with tungsten powder-coat finish on side and back. 12 grommets per lounge chair; 14 grommets per settee; 16 grommets per sofa. Shelf supports are nickel-plated steel.

Wood frame and shelves:
Natural veneer over 1 1/4" thick solid fiberboard core.

Upholstery:
Highly resilient Dymetrol seat suspension over black plywood frame attached to black 12-gauge steel frame. Welting detail with both leather and textile upholstery.

Cushion fill:
5" thick polycore with a soft, double-wrapped quilted dacron wrap for a softer sit. Cushion displays moderate crowning.

pattern no.	grades											COL		
	A	B	C	D	E	F	G	H	I	U	V	W	X	Y
66S2-M	\$6,295.	\$6,525.	\$6,753.	\$6,922.	\$7,066.	\$7,200.	\$7,345.	\$7,707.	\$8,385.	\$10,110.	\$10,951.	\$12,655.	\$13,009.	\$13,422.
66S2-Y	6,046.	6,274.	6,501.	6,671.	6,814.	6,945.	7,093.	7,457.	8,132.	9,859.	10,699.	12,403.	12,760.	13,174.

Approved KnollTextiles Grades/Fabrics

A	Alignment	Beacon	Bocce	Cat's Cradle	Chance	Common Ground	Commuter Cloth	Cotton Duck	Delite	Dristi	Hourglass	Mariner	Monarch	Prep	Presto	Soliloquy	Sonnet	Stacks	Trophy																											
B	continued	Digit	Digital Tape	Dovetail	Ferry	Gala II	Grande	Grandview	Holbrook	Journey	Keaton	Knoll Felt	Knoll Hopsack	Ludlow	Lyric	Mini Stitch	Night Life	Nonchalant CR	Paradigm	Petal Pusher	Pogo	Pop	Prairie	Prim	Prompt	Radiance	Ransom	Ricochet	Roam	Rush Hour	Soiree	Spark	Spinoff Nuance	Spree	Starry Night	Summit	Sutton	Synth	Tabloid	Venue	Versa	Vinyl	Westwood	Wide Angle	Zephyr	Zipline
C	Autobahn	Axiom	Baxter	Biota	Charm	Circa	Classic Boucle	Dahlia CR	Dune	Durand	Earthwork	Echo	Empire Stripe	Enmesh	Entourage	Fable CR	Fibra	Greenwich	Hudson	Hula Hoop	Kaleidoscope CR	Kora CR	Lagos	Legend CR	Lore CR	Metro	Milestone	Moto CR	Noble																	
C	continued	Palisade	Panache CR	Quark	Regard CR	Roundtrip	Sandpiper	Sequin CR	Sinclair	Smart	Spectator	Spot On	Star Struck	Stepping Stones	Swing	Tilden	Tower Grid	Transition	Treble CR	Zari CR																										
D	Compass CR	Coterie	Eclat Weave	Hologram	In The Loop	Island	Masquerade	Menagerie	Origins	Satellite	Satin Chisel	Tara	Theory	Woodland	Zoom																															
E	Highland	Ikat Square	Ikata Stripe	Kampala	Katazome	Kimono	Luberon	Mamba	Marquee	Meroe	Sherman	Shima	Tryst	Whip																																
F	Atelier	Biscayne	Calais Cotton	Velvet	Cornaro	Eclipse	Glider	Icon	Intrigue	Liberty	Mod Plaid	Rivington	Topography	Totem																																
G	Arabella	Arber	Djenne	Gibson	Hampshire																																									

Spinneybeck Leather

U	Vicenza	Volo									
V	Acqua	Andes	Embossed Tipped	España	Hand Tipped	Velluto Pelle					
W	Alaska	Amazon	Antique	Arizona	Derby						
W	continued	Forte	Lucente	Sabrina							
X	Ducale	Ducale Velour									
Y	Capri	Cervo	Copenhagen	Cordovan	Distressed	Lucca	Marissa	Portofino	Prima	Riva	Torello

Check with your KnollTextiles or Spinneybeck Representative for changes or additions.

Stamberg Aferiat Salsa® Lounge Seating

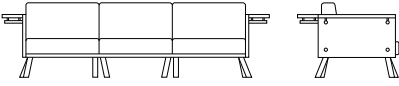
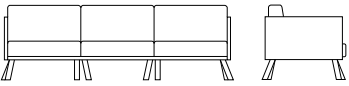
	description	seat h	arm h	w	d	h	textile fabric yds.	req. leather sq. ft.	weight
Designer(s): Peter Stamberg and Paul Aferiat, 1994 	66S3-M Sofa with grommets for shelves	16 ³ / ₄ "	24 ³ / ₈ "	104"	30"	29"	8.3	150	188 lbs.
									
	66S3-Y Sofa without grommets	16 ³ / ₄ "	24 ³ / ₈ "	88"	30"	29"	8.3	150	185 lbs.
									

Order Code

<i>Example:</i>	66S1-M-TF-B-K787/10 (2)66SH-A-TF-B
66S1	Lounge chair
M	Grommet option
TF	Tutti Frutti leg finishes
B	Natural Beech frame
K787/10	Calais Cotton Velvet, Lipstick
(2)66SH-A	Two arm shelves
TF	Tutti Frutti bracket finishes
B	Natural Beech shelf finish

Specify:

1. Pattern number
2. Grommet option
3. Leg finish selection
4. Wood frame finish
5. Textile selection
6. Arm shelf option pattern number
7. Shelf bracket finish
8. Shelf finish

Ordering Information

Grommet option:
Grommets (suffix M)
No grommets: (suffix Y)

Leg and shelf bracket finishes:
Real Red (suffix RR)
Nasturtium Orange (suffix NO)
Daffodil Yellow (suffix DY)
Spring Green (suffix SG)
Cornflower Blue (suffix CB)
Wisteria Violet (suffix WV)
Tutti Frutti, mix of all above colors (suffix TF)
Copper (suffix CO)
Tungsten (suffix TU)
Dark Metallic Grey (suffix V)

Custom mix of colors:
Add 5% to list price and provide descriptive drawing.

Wood frame and shelf finishes:
Maple (suffix K)
Natural Beech (suffix B)
Medium Red Mahogany (suffix Z)
Warm Brown Walnut (suffix J)
Ebonized Walnut (suffix D)

Side cushion:
Specify side cushions separately. Narrow side cushion recommended for lounge chairs.

Upholstery/COM information:
Prices shown include fabric or leather upholstery. Contact your Knoll representative for colors. Only approved Knoll Textiles and Spinneybeck leathers may be ordered.

Customer's Own Material is available pending approval. For approval requirements, processing instructions and ordering information please see page 18.

Shelf specification note:
Additional shelf options are listed on page 288. Shelves are shipped separately, and installed on site.

The Salsa Lounge Seating Collection is Greenguard certified.

Glides:
Plastic glides.

Maintenance:
See pages 28-29.

Construction

Grommets, legs & shelf supports:
1¹/₈"D x 8¹/₄"H legs are cold-rolled 14 gauge seamless steel tubing. 1¹/₄"D shelf supports are aluminum alloy. Copper and tungsten finishes are powder-coated finishes. Grommets are 1¹/₄" aluminum castings with tungsten powder-coat finish on side and back. 12 grommets per lounge chair; 14 grommets per settee; 16 grommets per sofa. Shelf supports are nickel-plated steel.

Wood frame and shelves:
Natural veneer over 1¹/₄" thick solid fiberboard core.

Upholstery:
Highly resilient Dymetrol seat suspension over black plywood frame attached to black 12-gauge steel frame. Welting detail with both leather and textile upholstery.

Cushion fill:
5" thick polycore with a soft, double-wrapped quilted dacron wrap for a softer sit. Cushion displays moderate crowning.

pattern no.	grades											COL		
	A	B	C	D	E	F	G	H	I	U	V	W	X	Y
66S3-M	\$8,518.	\$8,861.	\$9,206.	\$9,461.	\$9,684.	\$9,880.	\$10,104.	\$10,649.	\$11,671.	\$14,335.	\$15,498.	\$18,055.	\$18,690.	\$19,154.
66S3-Y	8,167.	8,513.	8,856.	9,105.	9,331.	9,532.	9,752.	10,300.	11,322.	13,985.	15,144.	17,702.	18,335.	18,803.

Approved KnollTextiles Grades/Fabrics

A	Alignment	Beacon	Bocce	Cat's Cradle	Chance	Common Ground	Commuter Cloth	Cotton Duck	Delite	Dristi	Hourglass	Mariner	Monarch	Prep	Presto	Soliloquy	Sonnet	Stacks	Trophy																											
B	continued	Digit	Digital Tape	Dovetail	Ferry	Gala II	Grande	Grandview	Holbrook	Journey	Keaton	Knoll Felt	Knoll Hopsack	Ludlow	Lyric	Mini Stitch	Night Life	Nonchalant CR	Paradigm	Petal Pusher	Pogo	Pop	Prairie	Prim	Prompt	Radiance	Ransom	Ricochet	Roam	Rush Hour	Soiree	Spark	Spinoff Nuance	Spree	Starry Night	Summit	Sutton	Synth	Tabloid	Venue	Versa	Vinyl	Westwood	Wide Angle	Zephyr	Zipline
C	Autobahn	Axiom	Baxter	Biota	Charm	Circa	Classic Boucle	Dahlia CR	Dune	Durand	Earthwork	Echo	Empire Stripe	Enmesh	Entourage	Fable CR	Fibra	Greenwich	Hudson	Hula Hoop	Kaleidoscope CR	Kora CR	Lagos	Legend CR	Lore CR	Metro	Milestone	Moto CR	Noble																	
C	continued	Palisade	Panache CR	Quark	Regard CR	Roundtrip	Sandpiper	Sequin CR	Sinclair	Smart	Spectator	Spot On	Star Struck	Stepping Stones	Swing	Tilden	Tower Grid	Transition	Treble CR	Zari CR	D	Compass CR	Coterie	Eclat Weave	Hologram	In The Loop	Island	Masquerade	Menagerie	Origins	Satellite	Satin Chisel	Tara	Theory	Woodland	Zoom										
E	Highland	Ikat Square	Kampala	Katazome	Kimono	Luberon	Mamba	Marquee	Meroe	Sherman	Shima	Tryst	Whip																																	
F	Atelier	Biscayne	Calais Cotton	Velvet	Cornaro	Eclipse	Glider	Icon	Intrigue	Liberty	Mod Plaid	Rivington	Topography	Totem																																
G	Arabella	Arber	Djenne	Gibson	Hampshire																																									

Spinneybeck Leather

U	Vicenza	Volo									
V	Acqua	Andes	Embossed Tipped	España	Hand Tipped	Velluto Pelle					
W	Alaska	Amazon	Antique	Arizona	Derby						
W	continued	Forte	Lucente	Sabrina							
X	Ducale	Ducale Velour									
Y	Capri	Cervo	Copenhagen	Cordovan	Distressed	Lucca	Marissa	Portofino	Prima	Riva	Torello





Check with your KnollTextiles or Spinneybeck Representative for changes or additions.

Stamberg Aferiat

Salsa® Lounge Seating Shelf and Side Cushion Options

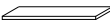
Designer(s):
Peter Stamberg and Paul Aferiat,
1994

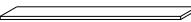

description	w	d	h	textile fabric yds.	req. leather sq. ft.	weight
66SH-A Arm shelf 	30 1/8"	8"	1 1/4"			11 lbs.
66SH-B Partial width single seat back shelf 	39 1/4"	8"	1 1/4"			13 lbs.
66SH-C Full width single seat back shelf 	47 1/4"	8"	1 1/4"			15 lbs.
66SH-D Partial width double seat back shelf 	67 1/4"	8"	1 1/4"			22 lbs.
66SH-E Full width double seat back shelf 	75 1/4"	8"	1 1/4"			25 lbs.
66SH-F Partial width triple seat back shelf 	96 1/4"	8"	1 1/4"			32 lbs.

Order Code

<i>Example:</i>	66SH-A-CO-D
66SH-A	Arm shelf
CO	Copper bracket
D	Ebonized Walnut shelf

Specify:

1. Pattern number
2. Bracket finish
3. Shelf finish

Ordering Information

Painted shelf bracket finishes:
Real Red (suffix RR)
Nasturtium Orange (suffix NO)
Daffodil Yellow (suffix DY)
Spring Green (suffix SG)
Cornflower Blue (suffix CB)
Wisteria Violet (suffix WV)
Tutti Frutti, mix of all above colors (suffix TF)
Copper (suffix CO)
Tungsten (suffix TU)
Dark Metallic Grey (suffix V)

Custom mix of colors:
For custom mix of colors, add 5% to list price and provide descriptive drawing.

Shelf finishes:
Maple (suffix K)
Natural Beech (suffix B)
Medium Red Mahogany (suffix Z)
Warm Brown Walnut (suffix J)
Ebonized Walnut (suffix D)

Shelf specification note:
Shelves are shipped separately, and installed on site. Partial width back shelves are non-handed with pre-drilled inserts for left or right installation.

Note:
The Salsa Lounge Seating Collection is Greenguard certified.

Maintenance:
See pages 28-29.

Construction

Shelf supports and spacers:
1 1/4" d shelf supports are aluminum alloy. Copper and tungsten finishes are powder-coated finishes. Shelf supports are nickel-plated steel.

Number of shelf supports per shelf:

A: 2 E: 3
B: 2 F: 4
C: 2 G: 4
D: 3

Shelves:
Natural veneer over 1 1/4" thick, solid fiberboard core.

pattern no.	list	grades	COM	A	B	C	D	E	F	G	H	I	COL	U	V	W	X	Y
66SH-A	\$500.																	
66SH-B	604.																	
66SH-C	705.																	
66SH-D	802.																	
66SH-E	905.																	
66SH-F	1,155.																	

Approved KnollTextiles Grades/Fabrics

A	Alignment Beacon Bocce Cat's Cradle Chance Common Ground Commuter Cloth Cotton Duck Delite Dristi Hourglass Mariner Monarch Prep Presto Soliloquy Sonnet Stacks Trophy	E continued Ferry Gala II Grande Grandview Holbrook Journey Keaton Knoll Felt Knoll Hopsack Ludlow Lyric Mini Stitch Night Life Nonchalant CR Paradigm Petal Pusher Pogo Pop Prairie Prim Prompt Radiance Ransom Ricochet Roam Rush Hour Soiree Spark Spinoff Nuance Spree Starry Night Summit Sutton Synth Tabloid Venue Versa Vinyl Westwood Wide Angle Zephyr Zipline	C Autobahn Axiom Baxter Biota Charm Circa Classic Boucle Dahlia CR Dune Durand Earthwork Echo Empire Stripe Enmesh Entourage Fable CR Fibra Greenwich Hudson Hula Hoop Kaleidoscope CR Kora CR Lagos Legend CR Lore CR Metro Milestone Moto CR Noble Palisade Panache CR Quark Regard CR Roundtrip Sandpiper Sequin CR Sinclair	C continued Smart Spectator Spot On Star Struck Stepping Stones Swing Tilden Tower Grid Transition Treble CR Zari CR	D Compass CR Coterie Eclat Weave Hologram In The Loop Island Masquerade Menagerie Origins Satellite Satin Chisel Tara Theory Woodland Zoom	E Highland Ikat Square Ikat Stripe Kampala Katazome Kimono Luberon Mamba Marquee Meroe
----------	--	---	---	--	--	---

Spinneybeck Leather

U Vicenza Volo	V Acqua Andes Embossed Tipped España Hand Tipped Velluto Pelle	W continued Forte Lucente Sabrina	X Ducale Ducale Velour	Y Capri Cervo Copenhagen Cordovan Distressed Lucca Marissa Portofino Prima Riva Torello
-----------------------------	---	---	-------------------------------------	---



Check with your KnollTextiles or Spinneybeck representative for changes or additions.

Stamberg Aferiat

Salsa® Lounge Seating Shelf and Side Cushion Options

Designer(s):
Peter Stamberg and Paul Aferiat,
1994

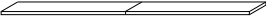

description	w	d	h	textile fabric yds.	req. leather sq. ft.	weight
66SH-G Full width triple seat back shelf 	104 1/4"	8"	1 1/4"			34 lbs.
66SC-N Narrow side cushion (single) 	3"	21"	9"	0.8	14	
66SC-W Wide side cushion (single) 	6"	21"	9"	0.8	14	

Order Code

<i>Example:</i>	66SH-A-CO-D
66SH-A	Arm shelf
CO	Copper bracket
D	Ebonized Walnut shelf

Specify:

1. Pattern number
2. Bracket finish
3. Shelf finish

Ordering Information

Painted shelf bracket finishes:
Real Red (suffix RR)
Nasturtium Orange (suffix NO)
Daffodil Yellow (suffix DY)
Spring Green (suffix SG)
Cornflower Blue (suffix CB)
Wisteria Violet (suffix WV)
Tutti Frutti, mix of all above colors (suffix TF)
Copper (suffix CO)
Tungsten (suffix TU)
Dark Metallic Grey (suffix V)

Custom mix of colors:
For custom mix of colors, add 5% to list price and provide descriptive drawing.

Shelf finishes:
Maple (suffix K)
Natural Beech (suffix B)
Medium Red Mahogany (suffix Z)
Warm Brown Walnut (suffix J)
Ebonized Walnut (suffix D)

Shelf specification note:
Shelves are shipped separately, and installed on site. Partial width back shelves are non-handed with pre-drilled inserts for left or right installation.

Note:
The Salsa Lounge Seating Collection is Greenguard certified.

Maintenance:
See pages 28-29.

Construction

Shelf supports and spacers:
1 1/4" d shelf supports are aluminum alloy. Copper and tungsten finishes are powder-coated finishes. Shelf supports are nickel-plated steel.

Number of shelf supports per shelf:

A: 2	E: 3
B: 2	F: 4
C: 2	G: 4
D: 3	

Shelves:
Natural veneer over 1 1/4" thick, solid fiberboard core.

pattern no.	list	grades	COM								COL				
		A	B	C	D	E	F	G	H	I	U	V	W	X	Y
66SH-G	\$1,352.														
66SC-N		281.	313.	350.	375.	392.	415.	435.	490.	586.	769.	887.	1,124.	1,178.	1,236.
66SC-W		281.	313.	350.	375.	392.	415.	435.	490.	586.	769.	887.	1,124.	1,178.	1,236.

Approved KnollTextiles Grades/Fabrics

A	Alignment Beacon Bocce Cat's Cradle Chance Common Ground Commuter Cloth Cotton Duck Delite Dristi Hourglass Mariner Monarch Prep Presto Soliloquy Sonnet Stacks Trophy	E continued Ferry Gala II Grande Grandview Holbrook Journey Keaton Knoll Felt Knoll Hopsack Ludlow Lyric Mini Stitch Night Life Nonchalant CR Paradigm Petal Pusher Pogo Pop Prairie Prim Prompt Radiance Ransom Ricochet Roam Rush Hour Betwixt Spark Spinoff Nuance Spree Starry Night Summit Sutton Synth Tabloid Venue Versa Vinyl Westwood Wide Angle Zephyr Zipline	C Autobahn Axiom Baxter Biota Charm Circa Classic Boucle Dahlia CR Dune Durand Earthwork Echo Empire Stripe Enmesh Entourage Fable CR Fibra Greenwich Hudson Hula Hoop Kaleidoscope CR Kora CR Lagos Legend CR Lore CR Metro Milestone Moto CR Noble Palisade Panache CR Quark Regard CR Roundtrip Sandpiper Sequin CR Sinclair	C continued Smart Spectator Spot On Star Struck Stepping Stones Swing Tilden Tower Grid Transition Treble CR Zari CR	D Compass CR Coterie Eclat Weave Hologram In The Loop Island Masquerade Menagerie Origins Satellite Satin Chisel Tara Theory Woodland Zoom	E Highland Ikat Square Ikat Stripe Kampala Katazome Kimono Luberon Mamba Marquee Meroe
----------	--	--	---	--	--	---

E continued Sherman Shima Tryst Whip	F Atelier Biscayne Calais Cotton Velvet Cornaro Eclipse Glider Icon Intrigue Liberty Mod Plaid Rivington Topography Totem	G Arabella Arber Djenne Gibson Hampshire Haze Kamani Kinabalu Kingston Melange Metallic Gloss Sablon Serendipity Spencer Straie Stripe Ultrasuede Utrillo
---	--	---

Spinneybeck Leather

U Vicenza Volo	V Acqua Andes Embossed Tipped España Hand Tipped Velluto Pelle	W continued Forte Lucente Sabrina	X Ducale Ducale Velour	Y Capri Cervo Copenhagen Cordovan Distressed Lucca Marissa Portofino Prima Riva Torello
-----------------------------	---	---	-------------------------------------	---

Check with your KnollTextiles or Spinneybeck representative for changes or additions.

Stamberg Aferiat

Salsa® Lounge Seating Specification Form

Lounge Seating Pattern Number						
Quantity	66S	Model	Grommet	Leg Color	Wood Finish	Upholstery
		1 Club Chair	Y no grommets	See below	See below	Textile
		2 Settee	M grommets			Leather
		3 Sofa				

Shelf Pattern Numbers			
Quantity	66SH	Type of Shelf	Bracket Color
			Wood Finish

- | | | |
|--|---|--|
| A
B
C
D
E
F
G | CO copper
TU tungsten
V dark metallic grey
RR real red
NO nasturtium orange
DY daffodil yellow
SG spring green
CB cornflower blue
WV wisteria violet
TF tutti frutti | K maple
B natural beech
Z med. red mahogany
J warm brown walnut
D ebonized walnut |
|--|---|--|

Side Cushions Pattern Number		
Quantity	66SC	Model
		N Narrow
		W Wide
		Upholstery
		Textile
		Leather

Type of Shelf Shelves are non-handed. They can be specified at left, right, top and bottom.

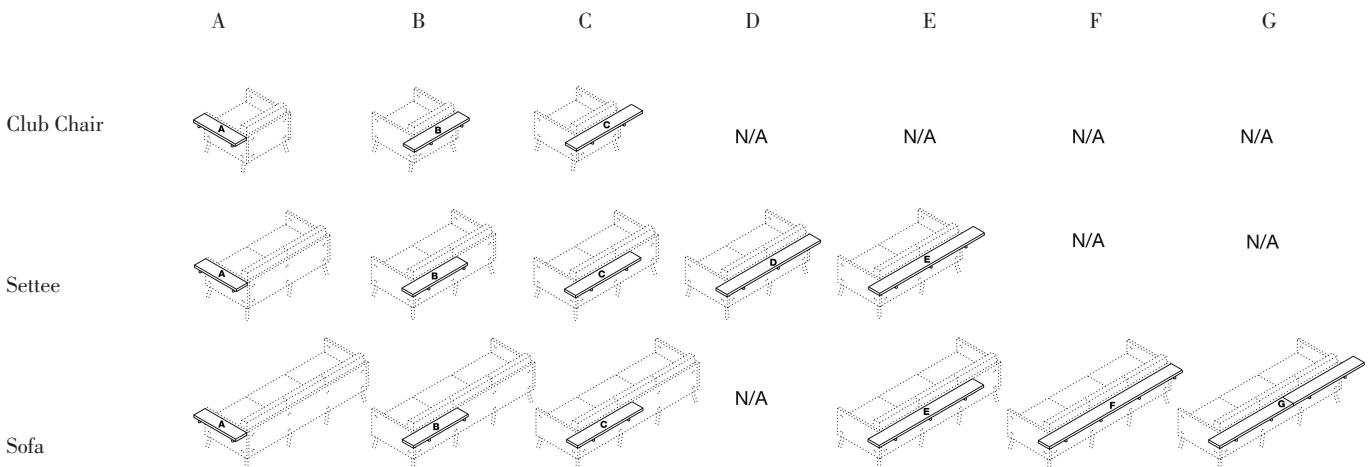

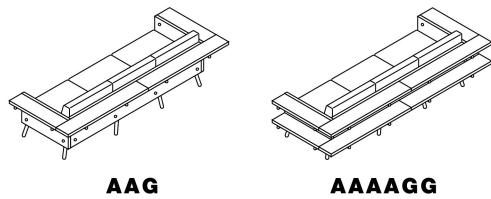
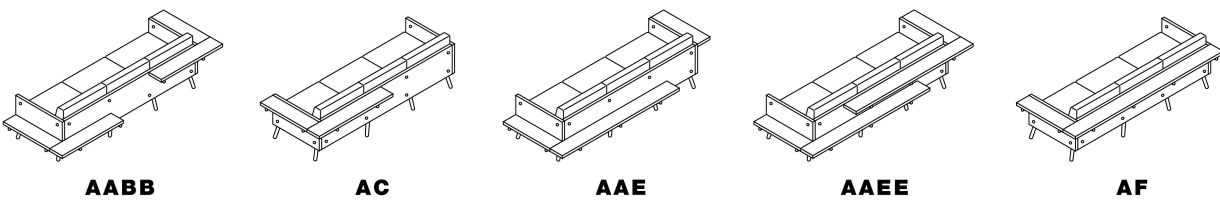
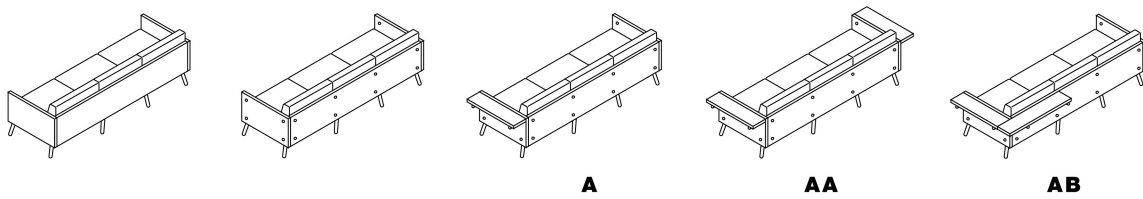
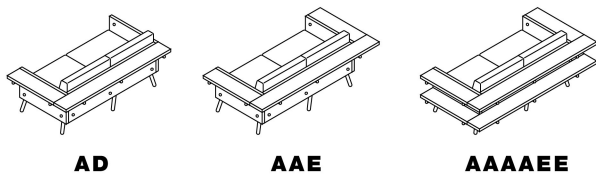
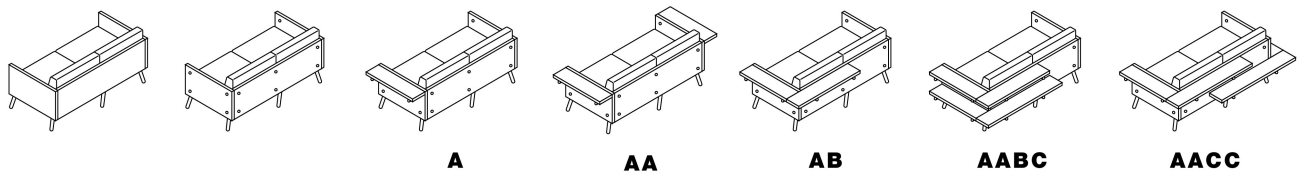
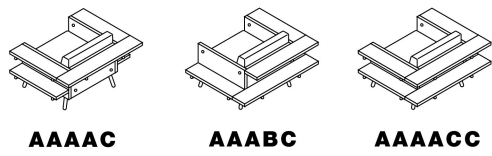
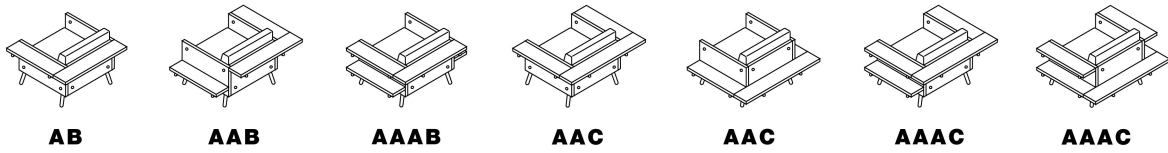
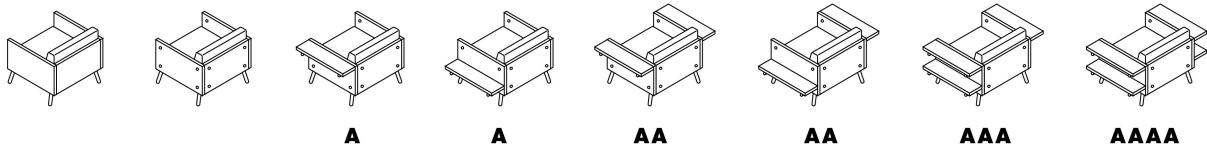

Recommended Shelf Combinations

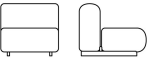
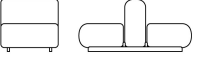

Kazuhide Takahama

Suzanne Lounge Seating

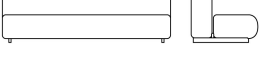
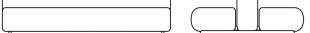
	description	seat h	w	d	h	textile fabric yds.	weight
<p><i>Designer(s):</i> Kazuhide Takahama, 1965</p> 	53S1 Lounge chair 	14 1/2"	30 1/2"	35"	27"	3.4	53 lbs.
	53D1 Double lounge chair 	14 1/2"	30 1/2"	59"	27"	4.6	79 lbs.
	53S2 Settee 	14 1/2"	60"	35"	27"	6.8	98 lbs.
	53D2 Double Settee 	14 1/2"	60"	59"	27"	8.7	150 lbs.
	53S3 Sofa 	14 1/2"	83"	35"	27"	10.2	146 lbs.
	53D3 Double Sofa 	14 1/2"	83"	59"	27"	12.4	225 lbs.

Order Code

<i>Example:</i>	53S1-K134/21
53S1	Suzanne lounge chair
K134/21	Bank Shot, Thyme

Specify:

1. Pattern number
2. Textile selection

Ordering Information

Upholstery/COM information:
Prices shown include fabric or leather upholstery. Contact your KnollStudio representative for colors .

Customer's Own Material is available pending approval. For approval requirements, processing instructions and ordering information please see page 18.

Maintenance:
See pages 28-29.

Notes:
The Suzanne Lounge Seating is Greenguard certified.

Split upholstery back and seat:
The Suzanne Lounge Collection may be specified with split upholstery, where the horizontal seat module and the vertical back module are upholstered in different textiles. Indicate B before selected back upholstery, followed by the selected seat upholstery. Price equals the higher upholstery grade.

COM split fabric requirements:

53S1 seat: 1.6 yards
 53S1 back: 1.8 yards
 53D1 seat: 3.2 yards
 53D1 back: 1.8 yards
 53S2 seat: 2.7 yards
 53S2 back: 2.8 yards
 53D2 seat: 4.4 yards
 53D2 back: 2.8 yards
 53S3 seat: 3.7 yards
 53S3 back: 4 yards
 53D3 seat: 7.4 yards
 53D3 back: 4 yards

Split upholstery side panel and main body:

The Suzanne Lounge Collection may be specified with split upholstery, where the side panels and the main body are upholstered in different textiles. Indicate P before selected side panel upholstery, followed by the selected main body upholstery. Price equals the higher upholstery grade.

COM split fabric requirements:

53S1 side: 0.9 yards
 53S1 main: 2.7 yards
 53D1 side: 1.2 yards
 53D1 main: 3.6 yards
 53S2 side: 0.9 yards
 53S2 main: 4.6 yards
 53D2 side: 1.2 yards
 53D2 main: 6.2 yards
 53S3 side: 0.9 yards
 53S3 main: 6.7 yards
 53D3 side: 1.2 yards
 53D3 main: 8.9 yards

pattern no.	Base Grade	grades A	COM B	C	D	E	F	G	H	I
53S1	\$1,854.	\$2,268.	\$2,343.	\$2,428.	\$2,528.	\$2,666.	\$2,746.	\$2,887.	\$2,981.	\$3,261.
53D1	3,039.	3,492.	3,600.	3,721.	3,865.	4,064.	4,181.	4,384.	4,519.	4,922.
53S2	3,224.	3,798.	3,935.	4,088.	4,270.	4,522.	4,669.	4,926.	5,096.	5,607.
53D2	5,129.	5,879.	6,072.	6,287.	6,543.	6,896.	7,103.	7,463.	7,702.	8,419.
53S3	5,062.	5,904.	6,103.	6,325.	6,590.	6,956.	7,169.	7,542.	7,790.	8,531.
53D3	7,931.	9,072.	9,347.	9,654.	10,018.	10,522.	10,816.	11,330.	11,672.	12,694.

Construction

Frame:
Aluminum extrusion, polished aluminum end caps and top edge. Brushed aluminum sides. Comes with plastic glides

Upholstery:
Separate high-resilient Cal 117 foam cushions with MDF seat and back supports structure.

Base Grade Textile

Fabric, Base Grade:
Green Tea (suffix KLF01)
Heirloom Tomato (suffix KLF02)
Blue Moon (suffix KLF03)
Earl Grey (suffix KLF04)
Chocolate Stout (suffix KLF05)
Black Tea (suffix KLF06)

Approved KnollTextiles Grades/Fabrics

- | | | |
|---|--|--|
| <p>A
Common Ground
Delite
Dristi
Hourlgass
Mariner
Presto *
Sonnet</p> <p>B
Bank Shot
Ferry
Journey
Knoll Felt
Knoll Hopsack
Prairie
Ricochet
Summit
Synth
Venue
Westwood</p> | <p>C
Classic Boucle
Dune
Entourage
Noble
Palisade
Smart
Spot On
Swing *
Tilden</p> <p>E
Highland
Marquee
Whip</p> <p>F
Atelier
Calais Cotton
Velvet
Cornaro
Intrigue
Tweed Frieze</p> | <p>G
Kingston
Melange
Metallic Gloss
Ultrasuede</p> <p>H
Bavaria
Firefly
Gezelle
Magritte</p> <p>I
Dynamic
Knoll Velvet
Tudor</p> |
|---|--|--|

* Fabric will be railroaded

Check with your KnollTextiles representative for changes or additions.

Ufficio Tecnico Spoleto Chair

Designer(s):
Ufficio Tecnico, 1971

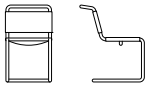

description	seat h	w	d	h	weight
50CS Spoleto armless chair 	18"	18 1/2"	23 1/2"	32"	17 lbs.
50KIT Replacement sling kit with nylon laces, cowhide					
50KIT Replacement sling kit with nylon laces, belting leather					
50LACE Replacement nylon laces for cowhide, belting leather and hair hide slings					

Order Code

<i>Example:</i>	50CS-BL1901
50CS	Spoleto armless chair
BL1901	Belting leather, Fudge

Specify:

1. Pattern number
2. Sling material and color selection

Ordering Information

Spinneybeck Belting Leather:

-  Black (suffix BLBLACK)
- Chocolate (suffix BL1902)
- Cognac (suffix BL1904)
- Dark Mustard (suffix BL1903)
- Dark Salmon (suffix BL1906)
- Deep Blue (suffix BL1912)
- Deep Green (suffix BL1911)
- Deep Purple (suffix BL1913)
- Fudge (suffix BL1901)
- Key Lime (suffix BL1910)
- Lemon Meringue (suffix BL1909)
- Simply Red (suffix BL1905)
- Sunshine (suffix BL1908)
- Sweet Potato (suffix BL1907)
- White (suffix BL1914)

Cowhide selection:

- Black (suffix L80)
- Light Brown (suffix L82)
- White Beige (suffix L84)

Haired Hide:

- Black (BLCKHH)
- Black and White (BKWHHH)
- Chestnut (suffix OA12HH)
- Coffee (suffix O18HH)
- Gold (suffix OCP5HH)
- Mahogany (suffix OA19HH)
- Tan (suffix OCP3HH)
- Tri-Color (3COLHH)

Upholstery/COM information:

Prices shown include leather upholstery.
Customer's Own Material is not available.

KnollStudio 20-day Program:

The Spoleto chair is available on the 20-day program in black belting leather. For more information, consult pages 30-33.

Maintenance:

See pages 28-29.

Note:

Please ask your Spinneybeck Representative for samples of the belting leather and haired hide.

pattern no.

50CS-() 	\$1,960.
50KIT-L ()	883.
50KIT-(BL, HH) ()	883.
50LACE-(L, BL, HH)-()	84.

Construction

Frame:

Seamless tubular steel in polished chrome finish.

Upholstery:

Cowhide Slings:

Thick cowhide leather slings in three colors. Edges dyed to match for Black and Light Brown colors. White Beige will have edges matching Light Brown cowhide color.

Belting Leather:

Highly durable Spinneybeck belting leather in fifteen colors. Belting leather edges will always match specified color.

Haired Hide:

Spinneybeck haired hide in eight colors. Haired Hide is a natural material, markings are one-of-a-kind and will vary from piece to piece.

Laces:

Nylon laces are dyed to match specified leather. Haired hide and belting leather option will have nylon laces.

Glides:





Four molded clear plastic glides with twin-pin snap-in construction included with all Spoleto chairs.

Replacement Slings:

Slings can be replaced in the field by field services or a furniture repair specialist. Kit includes back and seat replacement slings with nylon laces. Slings should be fitted by field services or by a professional upholsterer.

Vignelli Associates

Handkerchief Armless Chair

	description	seat h	w	d	h	textile fabric yds.	weight	
<p><i>Designer(s):</i> Vignelli Designs, 1983</p> 	4901 Armless chair, unupholstered shell	18"	23"	22 1/2"	29"		21 lbs.	
								
	4901K-N Armless chair, seat pad, non-stacking	18"	23"	22 1/2"	29"	0.7	23 lbs.	
								
	4901K-S Armless chair, seat pad, stacking	18"	23"	22 1/2"	29"	0.7	23 lbs.	
								
	49100D Stacking dolly		24 3/8"	26"	12"		10 lbs.	
	G Optional glides							

Order Code

<i>Example:</i>	4901-W-C
4901	Handkerchief unupholstered armless chair
W	White shell
C	Polished chrome frame

Note:
The Vignelli Handkerchief side chairs are part of a collection. Please refer to Vignelli PaperClip Tables on page 414.

Specify:

1. Pattern number
2. Shell color selection
3. Base finish selection
4. Glide option
5. Cal 133 Fire Code option for seat pad
6. Textile selection for seat pad

Ordering Information

Shell colors:
Black (suffix B)
Grey (suffix G)
Midnight (MD)
Red (suffix R)
White (suffix W)

Base finishes:
Polished Chrome (suffix C)

Upholstery/COM information:
Prices shown include fabric upholstery. Contact your Knoll representative for colors. Only approved KnollTextiles and Spinneybeck leathers may be ordered.

Customer's Own Material is available pending approval. For approval requirements, processing instructions and ordering information please see page 18.

Cal 133 Fire Code #:
The Handkerchief Chair complies with the California Technical Bulletin 133 standard if upholstered in Cal 133 approved upholstery. Specify suffix -C at end of pattern number and suffix -133 at end of textile selection. Upcharge applies, see page 19.

Maintenance:
See pages 28-29.

Note:
The Handkerchief Armless Chair is Greenguard certified.

Construction

Shell:
Compression-molded. Highly durable fiberglass reinforced polyester; with urethane paint finish.

Seat pad:
High-resilience polyurethane cushion bonded to a semi-rigid thermoformed support.

Base:
7/16" steel wire finished in brightly polished chrome.

Optional glides:
Nylon. (Add -G to end of pattern number)

Stacking bumper:
Black flexible urethane stacking pad secured between base and shell.

pattern no.	grades A	COM B	C	D	E	F	G	H	I
4901-(-)C		\$767.							
4901K-N-(-)C-(-)	1,114.	1,135.	1,160.	1,183.	1,205.	1,222.	1,245.	1,294.	1,329.
4901K-S-(-)C-(-)	1,155.	1,178.	1,202.	1,225.	1,245.	1,261.	1,286.	1,333.	1,369.
49100D		1,638.							
G		29.							

Approved KnollTextiles Grades/Fabrics

Stacking features:

4901 and 4901K-S chairs stack 15-20 high. Chairs without stacking bumper (4901K-N) do not stack.

Stacking dolly:

16 gauge steel with side bumper strips and four 5" casters (two which swivel). Total height of 24 chairs stacked on the dolly is 85".



A	B continued	C continued	E	G	H
Alignment	Prairie	Kaleidoscope CR	Highland	Arabella	Arno
Beacon	Prim ‡	Lagos	Ikat Square	Arber	Bavaria
Bocce	Radiance	Legend CR	Ikat Stripe	Djene	Constance
Cats Cradle	Ransom	Lore CR	Kampala	Gibson	Gezelle
Chance	Ricochet	Magnolia	Katazome	Hampshire	Magritte
Common Ground ‡	Roam	Milestone	Kimono	Kamani	Rosemond
Commuter Cloth	Rush Hour	Noble	Luberon	Kinabalu	
Delite	Soiree	Palisade	Marquee	Kingston	I
Hourglass	Spark	Regard CR	Meroe	Melange	Aswan
Monarch	Spree	Roundtrip	Sherman	Metallic Gloss	Byron
Prep	Starry Night	Sinclair	Triyst	Sablon	Canaan
Soliloquy	Sutton	Smart	Whip	Serendipity	Cato
Sonnet	Synth	Spectator		Straie Stripe	Cummings
Trophy	Tabloid	Spot On	F	Ultrasuede	Diamond Days
	Venue	Stepping Stones	Atelier	Utrillo	Digi Velvet
B	Versa	Tight Rope	Biscayne		Dynamic
Argyle	Westwood	Tilden	Cornaro		Gates
Bank Shot	Wide Angle	Tower Grid	Eclipse		Ita
Belize		Transition	Fiori		Jaipur
Betwixt	C	Treble CR	Glider		Mepal
Bistro	Atlas		Intrigue		Olema
Boundary	Autobahn	D	Liberty		Piper
Cameo	Axiom	Coterie	Mod Plaid		Sandis
Chroma ‡	Baxter	Eclat Weave	Rivington		Tudor
Chronicle	Biota	In The Loop	Soon		Vermeer
Close Knit	Cairo	Masquerade	Topography		Walker
Digit	Cairo	Menagerie	Tweed Frieze		Worth
Dovetail	Circa	Origins			Zimba
Ferry	Classic Boucle	Satellite			
Gala II	Compass CR	Satin Chisel			
Grandview	Dahlia CR	Tara			
Holbrook	Decade	Theory			
Journey	Durand				
Knoll Felt	Enmesh				
Knoll Hopsack	Entourage				
Ludlow	Fable CR				
Lyric	Fibra				
Mini Stitch	Greenwich				
Paradigm	Hudson				
Petal Pusher	Hula Hoop				
Pogo ‡					

‡ Approved for Cal 133 upholstery.

Check with your KnollTextiles representative for changes or additions.

Vignelli Associates

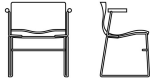
Handkerchief Arm Chair

	description	seat h	arm h	w	d	h	textile fabric yds.	weight
<p><i>Designer(s):</i> Vignelli Designs, 1983</p> 	4902 Arm chair, unupholstered shell	18"	26"	26"	22½"	29"		24 lbs.
								
	4902K-N Arm chair, seat pad, non-stacking	18"	26"	26"	22½"	29"	0.7	26 lbs.
								
	4902K-S Arm chair, seat pad, stacking	18"	26"	26"	22½"	29"	0.7	26 lbs.
								
	49100D Stacking dolly			24⅞"	26"	12"		10 lbs.
	G Glides (add -G to end of pattern number)							

Order Code

<i>Example:</i>	4902-MD-C
4902	Handkerchief unupholstered arm chair
MD	Midnight shell
C	Chrome frame

Note:

The Vignelli Handkerchief side chairs are part of a collection. Please refer to Vignelli PaperClip Tables on page 414.

Specify:

1. Pattern number
2. Shell color selection
3. Base finish selection
4. Glide option
5. Cal 133 Fire Code option for seat pad
6. Textile selection for seat pad

Ordering Information

Shell colors:
Black (suffix B)
Grey (suffix G)
Midnight (MD)
Red (suffix R)
White (suffix W)

Base finishes:
Polished Chrome (suffix C)

Upholstery/COM information:
Prices shown include fabric upholstery. Contact your Knoll representative for colors. Only approved KnollTextiles and Spinneybeck leathers may be ordered.

Customer's Own Material is available pending approval. For approval requirements, processing instructions and ordering information please see page 18.

Cal 133 Fire Code:
The Handkerchief Chair complies with the California Technical Bulletin 133 standard if upholstered in Cal 133 approved upholstery. Specify suffix -C at end of pattern number and suffix -133 at end of textile selection. Upcharge applies, see page 19.

Maintenance:
See pages 28-29.

Note:
The Handkerchief Arm Chair is Greenguard certified.

Construction

Shell:
Compression-molded. Highly durable fiberglass reinforced polyester; with urethane paint finish.

Seat pad:
High-resilience polyurethane cushion bonded to a semi-rigid thermoformed support.

Base:
7/16" steel wire finished in brightly polished chrome.

Optional glides:
Nylon. (Add -G to end of pattern number)

Stacking bumper:
Black flexible urethane stacking pad secured between base and shell.

pattern no.	grades A	COM B	C	D	E	F	G	H	I
4902-(-)C	\$956.								
4902K-N-(-)C-(-)	1,258.	1,280.	1,302.	1,328.	1,349.	1,365.	1,373.	1,437.	1,472.
4902K-S-(-)C-(-)	1,296.	1,319.	1,342.	1,368.	1,388.	1,403.	1,428.	1,475.	1,511.
49100D	1,638.								
G [4902]	29.								

Approved KnollTextiles Grades/Fabrics

Stacking features:

4902 and 4902K-S chairs stack 15-20 high. Chairs without stacking bumper (4902K-N) do not stack.

Stacking dolly:



16 gauge steel with side bumper strips and four 5" casters (two which swivel). Total height of 24 chairs stacked on the dolly is 85".

A	B continued	C continued	E	G	H
Alignment	Prairie	Kaleidoscope CR	Highland	Arabella	Arno
Beacon	Prim ‡	Lagos	Ikat Square	Arber	Bavaria
Bocce	Radiance	Legend CR	Ikat Stripe	Gibson	Constance
Cats Cradle	Ransom	Lore CR	Katazome	Hampshire	Gezelle
Chance	Ricochet	Magnolia	Kimono	Kamani	Magritte
Common Ground ‡	Roam	Milestone	Kampala	Kinabalu	Rosemond
Commuter Cloth	Rush Hour	Noble	Luberon	Kingston	
Delite	Soiree	Palisade	Marquee	Djenne	I
Hourglass	Spark	Regard CR	Meroe	Melange	Aswan
Monarch	Spree	Roundtrip	Sherman	Metallic Gloss	Byron
Prep	Starry Night	Sinclair	Tryst	Sablon	Canaan
Soliloquy	Sutton	Smart	Whip	Serendipity	Cato
Sonnet	Synth	Spectator		Straie Stripe	Cummings
Trophy	Tabloid	Spot On	F	Ultrasede	Diamond Days
	Venue	Stepping Stones	Atelier	Utrillo	Digi Velvet
B	Versa	Tight Rope	Biscayne		Dynamic
Argyle	Westwood	Tilden	Cornaro		Gates
Bank Shot	Wide Angle	Tower Grid	Eclipse		Ita
Belize		Transition	Fiori		Jaipur
Betwixt	C	Treble CR	Glider		Mepal
Bistro	Atlas		Intrigue		Olema
Boundary	Autobahn	D	Liberty		Piper
Cameo	Axiom	Coterie	Mod Plaid		Sandis
Chroma ‡	Baxter	Eclat Weave	Rivington		Tudor
Chronicle	Biota	In The Loop	Soon		Vermeer
Close Knit	Cairo	Masquerade	Topography		Walker
Digit	Circa	Menagerie	Tweed Frieze		Worth
Dovetail	Classic Boucle	Origins			Zimba
Ferry	Compass CR	Satellite			
Gala II	Dahlia CR	Satin Chisel			
Grandview	Decade	Tara			
Holbrook	Durand	Theory			
Journey	Enmesh				
Keaton	Entourage				
Knoll Felt	Fable CR				
Knoll Hopsack	Fibra				
Ludlow	Greenwich				
Lyric	Hudson				
Mini Stitch	Hula Hoop				
Paradigm					
Petal Pusher					
Pogo ‡					

‡ Approved for Cal 133 upholstery.

Check with your KnollTextiles representative for changes or additions.

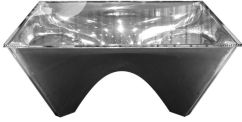
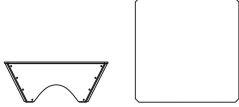
David Adjaye
The Washington Collection for Knoll™
Corona™ Coffee Table

	description	w	d	h	base	weight
Designer(s): David Adjaye, 2013 	WC1T Washington Corona™ bronze coffee table 	40 3/4"	40 3/4"	15 3/4"	Bronze	450 lbs.
	WC2T Washington Corona™ aluminum coffee table, black painted 	40 3/4"	40 3/4"	15 3/4"	Aluminum	170 lbs.

Order Code

Example: **WC2T**
WC2T Aluminum coffee table,
 black painted

Specify:
 1. Pattern number

Ordering Information

Glass finish:
 Clear glass
Maintenance:
 See pages 28-29.

Construction

Clear glass top:
 Top is 1/2" thick optically clear glass with a jewel-polished, chamfered edge.

Bronze base:
 Constructed from four sand-cast bronze panels, connected by machined bronze plates and brass hardware. The interior of the panels are CNC-machined and hand-polished to a mirror finish, contrasting the rough hewn exterior.

Aluminum base:
 Constructed from four die-cast aluminum panels, connected by aluminum connector plates and stainless steel hardware. The interior of the panels are finished in a smooth gloss black powder coat paint, contrasting the matte textured black powder coat paint exterior.

Note:
 To mark our 75th anniversary, the Washington Corona coffee table in bronze is limited to an edition of 75. Each piece is numbered and comes with a commemorative signature plate.

The Washington Corona coffee table is Greenguard certified.

pattern no

clear glass

WC1T

\$103,000.

WC2T

9,013.

David Adjaye
The Washington Collection for Knoll™
Prism™ Side Table

	description	w	d	h
<i>Designer(s):</i> David Adjaye, 2014	WL25 Side table	17"	14½"	18"

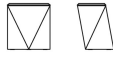

Award(s):
 Editors Choice Award, Lounge
 Furniture Collection, NeoCon
 June 2015, USA; MetropolisLikes
 Award, Metropolis Magazine,
 June 2015, USA



Order Code

<i>Example:</i>	WL25-118G-MCS
WL25	Side table
118G	White base
MCS	Satin Calacatta

Specify:

1. Pattern number
2. Base finish selection
3. Marble selection

Ordering Information

Base finishes:

Black (suffix 111G)
 White (suffix 118G)
 Red (suffix 845G)

Polished Coated marble top finishes:

Arabescato: white-grey (suffix MA)
 Calacatta: white-grey/beige (suffix MC)
 Grey Marble: light grey (suffix GG)
 Nero Marquina: black (suffix MN)
 Verdi Alpi: green (suffix MV)

Satin Coated marble top finishes:

Arabescato: white-grey (suffix MAS)
 Calacatta: white-grey/beige (suffix MCS)
 Grey Marble: light grey (suffix GGS)
 Nero Marquina: black (suffix MNS)
 Verdi Alpi: green (suffix MVS)

Maintenance:

See pages 28-29.

Construction

Base:

Constructed of ¾" Baltic Birch plywood panels covered in a plastic color core laminate which maintains color throughout so vibrancy is maintained from edge to edge. Panels are assembled together using poplar wood corner blocks.

pattern no	MA, MAS, GG, GGS, MN, MNS	MC, MCS	MV, MVS
WL25-()-()	\$7,303.	\$7,576.	\$7,701.

Franco Albini

Albini Desk

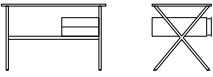
	description	w	d	h	weight
<p><i>Designer(s):</i> Franco Albini, 1938</p> 	<p>80D Pedestal desk</p> 	48"	26"	27 1/2"	95 lbs.



Order Code

<i>Example:</i>	80D-E
80D	Albini desk
E	Ebonized Oak pedestal

Specify:

1. Pattern number
2. Pedestal finish

Ordering Information

Albini pedestal finishes:
 Ebonized Oak (suffix E)
 White Lacquer (suffix L2)

 *20-Day:*
 The Albini desk in ebonized oak finish is available on the KnollStudio 20-Day program. For specific information consult pages 30-33.

Maintenance:
 See pages 28-29.

Construction

Base:
 Frame and legs in square steel tube with chrome finish.

Top:
 1/2" clear tempered glass.

Pedestal:
 2 drawer "floating" wood pedestal. Rear open shelf for magazines or small books.

Pedestal dimensions:
 16 1/2" w x 26" d x 8 1/4" h

Drawer dimensions:
 14 1/8" w x 14 1/8" d x 2 1/2" h

Rear shelf dimensions:
 15 1/2" w x 8 1/2" d x 7" h

Drawer mounts only on the right side.

pattern no.

80D-(E, L2) 

\$5,941.

Edward Barber & Jay Osgerby

Piton™ Side Table

	description	w	d	h	top finish	weight
<i>Designer(s):</i> Edward Barber and Jay Osgerby, 2014	BO21T side table 	16 1/4"	16 1/4"	21 1/4"	Ash	16 lbs.
		16 1/4"	16 1/4"	21 1/4"	Teak	16 lbs.



Order Code

<i>Example:</i>	BO21T-K-WHTT
BO21T	Side Table
K	Teak
WHTT	White

Specify:

1. Pattern number
2. Top selection
3. Base selection

Ordering Information

Wood Top Finishes:
Ebonized Ash (suffix AE)
Teak, natural (suffix K)

Base Paint Finishes:
Jet Black (suffix 111T)
Medium Metallic Grey (suffix 612T)
Red Coral (suffix CRLT)
Sterling (suffix 906T)
White (suffix WHTT)

Maintenance:
See pages 28-29.

Construction

Base:
Base is constructed of die-cast aluminum with stainless steel fasteners and finished with a highly durable powder coat in a variety of colors.

Wood Tops:
Knife edge wood tops are available in ebonized ash or an oiled teak.

pattern no.	list
BO21T-AE-()	\$995.
BO21T-K-()	1.250.

Marcel Breuer

Laccio Tables

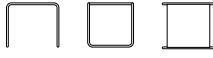
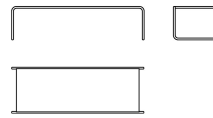
	description	w	d	h	weight
<i>Designer(s):</i> Marcel Breuer, 1924 	50T1 Laccio side table 	21 3/4"	19"	17 3/4"	13 lbs.
	50T2 Laccio coffee table 	53 1/2"	19"	13 1/2"	29 lbs.

Order Code





<i>Example:</i>	50T1-F1
50T1	Laccio side table
F1	Black Laminate

Note:
Laccio tables are part of a collection. Please refer to the Cesca and Wassily chairs on pages 86 and 90.

Specify:

1. Pattern number
2. Top finish selection

Ordering Information

Top finishes:
 Black (suffix F1)
 Red (suffix F3)
 White (suffix F2)
 *KnollStudio 20-Day Program:*
 Laccio tables in black and white laminates are available on the 20-day program. For specific information, consult pages 30-33.

Maintenance:
See pages 28-29.

Note:
The KnollStudio logo and signature of Marcel Breuer is stamped into the base of the table.

Construction

Top:
Satin finish, smooth plastic laminate.

Base:
Frame and legs seamless tubular steel in polished chrome finish.

pattern no.

50T1-() 



\$870.

50T2-() 

1,231.

Joseph Paul D'Urso

Square Work and Low Tables

description	width between legs		h, work tables	h, low tables	weight	top
	w	d				
6348 Square table, medium 	22 1/2"	48"	27 1/2"	15 1/4"	130 lbs.	laminata
	22 1/2"	48"	27 1/2"	15 1/4"	128 lbs.	figured techgrain®
	22 1/2"	48"	27 1/2"	15 1/4"	128 lbs.	natural veneer
	22 1/2"	48"	27 1/2"	15 1/4"	197 lbs.	natural marble
	22 1/2"	48"	27 1/2"	15 1/4"	197 lbs.	coated marble
6354 Square table, medium 	25 3/8"	54"	27 1/2"	15 1/4"	145 lbs.	laminata
	25 3/8"	54"	27 1/2"	15 1/4"	141 lbs.	figured techgrain®
	25 3/8"	54"	27 1/2"	15 1/4"	141 lbs.	natural veneer
	25 3/8"	54"	27 1/2"	15 1/4"	241 lbs.	natural marble
	25 3/8"	54"	27 1/2"	15 1/4"	241 lbs.	coated marble
6360 Square table, large 	25 3/8"	60"	27 1/2"	15 1/4"	183 lbs.	laminata
	25 3/8"	60"	27 1/2"	15 1/4"	179 lbs.	figured techgrain®
	25 3/8"	60"	27 1/2"	15 1/4"	179 lbs.	natural veneer
	25 3/8"	60"	27 1/2"	15 1/4"	288 lbs.	natural marble
	25 3/8"	60"	27 1/2"	15 1/4"	288 lbs.	coated marble
25 3/8"	60"	27 1/2"	15 1/4"	338 lbs.	granite	
GL Glides						
C Casters						
CX Locking casters						

Designer(s):
Joseph Paul D'Urso, 1980

Award(s):
Design Center Stuttgart Award, W. Germany, 1983; Federal Award for Industrial Design, W. Germany, 1983



Order Code





Example:	6354L-C-111-C
6354	54" square table
L	Low height
C	Casters
111	Jet Black laminate
C	Polished Chrome

Specify:

1. Pattern number
2. Specify L for low height tables
3. Glides/casters selection
4. Top finish selection
5. Leg finish selection

Ordering Information

Laminate top finishes:

-  Bright White (suffix 118)
-  Fog (suffix 128)
-  Jet Black (suffix 111)
-  Light Grey (suffix L)
-  Pumice (suffix 119)

Figured Techgrain top finishes:

- American Cherry (suffix P)
- Cherry (suffix R)
- Maple (suffix M)
- Medium Red Mahogany (suffix C)

Natural veneer top finishes:

- American Cherry (suffix X)
- Maple (suffix K)

Natural marble top finishes:

- Carrara: white-grey (suffix NGC)
- Emperador Dark: dark brown (suffix NGE)

Coated marble top finishes:

- Carrara: white-grey (suffix GC)
- Emperador Dark: dark brown (suffix GE)
- Empire Beige: beige (suffix GB)

Granite top finishes:

- Black Andes: black (suffix GA)

Low Tables:

D'Urso tables are available in two heights: standard and low. For low tables, add an L after the parent pattern number. Example: 6348L for low height option.

Leg finishes:

-  Jet Black (suffix 111)
- Medium Metallic Grey (suffix 612)
- Polished Chrome (suffix C)
- Red (suffix RD)

Glides/ casters:

- Casters (suffix C)
-  Glides, standard option (suffix GL)
- Locking casters (suffix CX)

KnollStudio 20-Day Program:

The D'Urso 6348 Work Table is available on the KnollStudio 20-Day program with black legs and glides. All laminates in stock can be specified for top finishes. For specific information, consult pages 30-33.

Maintenance:

See pages 28-29.

Note:

D'Urso Tables with Laminate, Veneer or Granite tops and PVC edge are Greenguard certified.

Weight information above is based on work height tables. For weight information on low height tables, please contact your KnollStudio representative.

pattern no.	upcharge	base painted	base chrome
6348-(-)(-)(-)		\$2,582.	\$3,016.
6348-(-)(-)(-)		3,711.	4,143.
6348-(-)(-)(-)		4,350.	4,782.
6348-(-)(NGC, NGE)-()		6,057.	6,491.
6348-(-)(GC, GB, GE)-()		7,030.	7,463.
6354-(-)(-)(-)		2,680.	3,112.
6354-(-)(-)(-)		3,810.	4,244.
6354-(-)(-)(-)		4,498.	4,932.
6354-(-)(NGC, NGE)-()		7,109.	7,540.
6354-(-)(GC, GB, GE)-()		8,335.	8,767.
6354-(-)GA-()		9,540.	9,970.
6360-(-)(-)(-)		2,919.	3,350.
6360-(-)(-)(-)		4,302.	4,733.
6360-(-)(-)(-)		5,192.	5,624.
6360-(-)(NGC, NGE)-()		8,226.	8,659.
6360-(-)(GC, GB, GE)-()		9,729.	10,161.
6360-(-)GA-()		10,723.	11,156.
GL	n/c		
C	623.		
CX	711.		

Construction

Top:
Laminate, Techgrain® and veneer or stone surface. Laminate, Techgrain® and veneer tops are 3-ply construction with medium density fiberboard core and plastic laminate backer (laminate tops) or paper backer (wood veneer tops). Laminate, Techgrain® and veneer tops have a black vinyl bullnose edge. Wood tops are longitudinal veneered. 7/8" thick stone tops have an integral, hand-crafted bullnose edge.

Edge detail:
Laminate/Techgrain/wood tops:

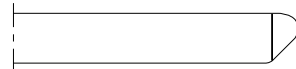

Stone tops:

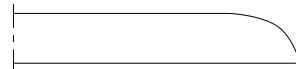

Base:
Racetrack-shaped steel legs with painted or polished chrome finish.

Glides:
Black nylon.





Casters:
3" single, black hard-rubber wheel. Polished chrome wheel housings with black or medium metallic grey legs. Black housings with polished chrome and red leg. Locking caster housings always polished chrome. Tables with casters are at the same height as tables with glides.

Wood tables with casters are weighted with steel plates to ensure stability. Plates are painted and secured under table top.

Please note: Casters cannot be retrofitted to tables with glides.

Joseph Paul D'Urso

Round Work and Low Tables

	description	width		h, work tables	h, low tables	weight	top
		between legs	w				
<i>Designer(s):</i> Joseph Paul D'Urso, 1980	6242 Round table, small 	20 7/8"	42"	27 1/2"	15 1/4"	110 lbs.	laminata
		20 7/8"	42"	27 1/2"	15 1/4"	109 lbs.	figured techgrain®
		20 7/8"	42"	27 1/2"	15 1/4"	109 lbs.	natural veneer
		20 7/8"	42"	27 1/2"	15 1/4"	132 lbs.	natural marble
		20 7/8"	42"	27 1/2"	15 1/4"	132 lbs.	coated marble
<i>Award(s):</i> Design Center Stuttgart Award, W. Germany, 1983; Federal Award for Industrial Design, W. Germany, 1983	6248 Round table, medium 	22 1/2"	48"	27 1/2"	15 1/4"	120 lbs.	laminata
		22 1/2"	48"	27 1/2"	15 1/4"	118 lbs.	figured techgrain®
		22 1/2"	48"	27 1/2"	15 1/4"	118 lbs.	natural veneer
		22 1/2"	48"	27 1/2"	15 1/4"	162 lbs.	natural marble
		22 1/2"	48"	27 1/2"	15 1/4"	162 lbs.	coated marble
 	6254 Round table, medium 	25 3/8"	54"	27 1/2"	15 1/4"	156 lbs.	laminata
		25 7/8"	54"	27 1/2"	15 1/4"	153 lbs.	figured techgrain®
		25 3/8"	54"	27 1/2"	15 1/4"	153 lbs.	natural veneer
		25 3/8"	54"	27 1/2"	15 1/4"	197 lbs.	natural marble
		25 3/8"	54"	27 1/2"	15 1/4"	197 lbs.	coated marble
	25 7/8"	54"	27 1/2"	15 1/4"	229 lbs.	granite	
	C Casters						
	GL Glides						
	CX Locking casters						

Order Code





<i>Example:</i>	6248-C-NGE-C
6248	48" diameter round table
C	Casters
NGE	Emperador Dark Marble
C	Polished Chrome

Specify:

1. Pattern number
2. Specify L for low height tables
3. Glides/casters selection
4. Top finish selection
5. Leg finish selection

Ordering Information

Laminata top finishes:

-  Bright White (suffix 118)
-  Fog (suffix 128)
-  Jet Black (suffix 111)
-  Light Grey (suffix L)
-  Pumice (suffix 119)

Figured Techgrain top finishes:

- American Cherry (suffix P)
- Cherry (suffix R)
- Maple (suffix M)
- Medium Red Mahogany (suffix C)

Natural veneer top finishes:

- American Cherry (suffix X)
- Maple (suffix K)

Natural marble top finishes:

- Carrara: white-grey (suffix NGC)
- Emperador Dark: dark brown (suffix NGE)

Coated marble top finishes:

- Carrara: white-grey (suffix GC)
- Emperador Dark: dark brown (suffix GE)
- Empire Beige: beige (suffix GB)

Granite top finishes

- Black Andes: black (suffix GA)

Leg finishes:

-  Jet Black (suffix 111)
- Medium Metallic Grey (suffix 612)
- Polished Chrome (suffix C)
- Red (suffix RD)

Glides/casters:

- Casters (suffix C)
-  Glides, standard option (suffix GL)
- Locking casters (suffix CX)

Low Tables:

D'Urso tables are available in two heights: standard and low. For low tables, add an L after the parent pattern number. Example: 6348L for low height option.

pattern no.	upcharge	base painted	base chrome
6242-(-)(-)(-) 		\$2,442.	\$2,872.
6242-(-)(-)(-)		3,610.	4,040.
6242-(-)(-)(-)		4,251.	4,681.
6242-(-)(NGC, NGE)-()		4,409.	4,840.
6242-(-)(GC, GB, GE)-()		4,996.	5,426.
6248-(-)(-)(-)		2,582.	3,016.
6248-(-)(-)(-)		3,711.	4,143.
6248-(-)(-)(-)		4,350.	4,782.
6248-(-)(NGC, NGE)-()		5,192.	5,622.
6248-(-)(GC, GB, GE)-()		5,960.	6,390.
6254-(-)(-)(-)		2,680.	3,112.
6254-(-)(-)(-)		3,810.	4,244.
6254-(-)(-)(-)		4,498.	4,932.
6254-(-)(NGC, NGE)-()		6,085.	6,517.
6254-(-)(GC, GB, GE)-()		7,057.	7,488.
6254-(-)GA-()		9,746.	10,178.
C	623.		
GL	n/c		
CX	711.		

Construction

 **KnollStudio 20-Day Program:**
The 6242 D'Urso Work Table with black legs and glides is available on the KnollStudio 20-Day program. All laminates in stock can be specified for the top finish. For specific information, consult pages 30-33.

Maintenance:
See pages 28-29.

Note:
The D'Urso Tables with Laminate, Veneer or Granite tops and PVC edge are Greenguard certified.

Weight information above is based on work height tables. For weight information on low height tables, please contact your KnollStudio representative.

Top:
Laminate, Techgrain® and veneer or stone surface. Laminate, Techgrain® and veneer tops are 3-ply construction with medium density fiberboard core and plastic laminate backer (laminate tops) or paper backer (wood veneer tops). Laminate, Techgrain® and veneer tops have a black vinyl bullnose edge. $\frac{3}{4}$ " thick stone tops have an integral, hand-crafted bullnose edge.

Edge detail:
Laminate/Techgrain/wood tops

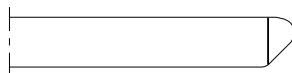

Stone tops:

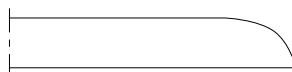

Base:
Racetrack-shaped steel legs with painted or polished chrome finish.

Glides:
Black nylon.



Casters:
3" single, black hard-rubber wheel. Polished chrome wheel housings with black or medium metallic grey legs. Black housings with polished chrome and red leg. Locking caster housings always polished chrome.

Wood tables with casters are weighted with steel plates to ensure stability. Plates are painted and secured under table top.

Please note: Casters cannot be retrofitted to tables with glides.

Joseph Paul D'Urso

Round Work and Low Tables

	description	width		h, work tables	h, low tables	weight	top
		between legs	w				
Designer(s): Joseph Paul D'Urso, 1980 Award(s): Design Center Stuttgart Award, W. Germany, 1983; Federal Award for Industrial Design, W. Germany, 1983	6260 Round table, large 	25 3/8"	60"	27 1/2"	15 1/4"	164 lbs.	figured techgrain®
		25 3/8"	60"	27 1/2"	15 1/4"	164 lbs.	natural veneer
		25 3/8"	60"	27 1/2"	15 1/4"	167 lbs.	laminare
		25 3/8"	60"	27 1/2"	15 1/4"	235 lbs.	coated marble
		25 3/8"	60"	27 1/2"	15 1/4"	235 lbs.	natural marble
		25 3/8"	60"	27 1/2"	15 1/4"	274 lbs.	granite
	6272 Round table, large 	31"	72"	27 1/2"	15 1/4"	255 lbs.	Natural veneer
	C Casters						
	GL Glides						
	CX Locking casters						



Order Code





<i>Example:</i>	6248-C-NGE-C
6248	48" diameter round table
C	Casters
NGE	Emperador Dark Marble
C	Polished Chrome

Specify:

1. Pattern number
2. Specify L for low height tables
3. Glides/casters selection
4. Top finish selection
5. Leg finish selection

Order Information

Laminate top finishes:

-  Bright White (suffix 118)
-  Fog (suffix 128)
-  Jet Black (suffix 111)
-  Light Grey (suffix L)
-  Pumice (suffix 119)

Figured Techgrain top finishes:

- American Cherry (suffix P)
- Cherry (suffix R)
- Maple (suffix M)
- Medium Red Mahogany (suffix C)

Natural veneer top finishes:

- American Cherry (suffix X)
- Maple (suffix K)

Natural marble top finishes:

- Carrara: white-grey (suffix NGC)
- Emperador Dark: dark brown (suffix NGE)

Coated marble top finishes:

- Carrara: white-grey (suffix GC)
- Emperador Dark: dark brown (suffix GE)
- Empire Beige: beige (suffix GB)

Granite top finishes

- Black Andes: black (suffix GA)

Leg finishes:

-  Jet Black (suffix 111)
- Medium Metallic Grey (suffix 612)
- Polished Chrome (suffix C)
- Red (suffix RD)

Glides/casters:

- Casters (suffix C)
-  Glides, standard option (suffix GL)
- Locking casters (suffix CX)

Low Tables:

D'Urso tables are available in two heights: standard and low. For low tables, add an L after the parent pattern number. Example: 6348L for low height option.

pattern no.	upcharge	base, painted	base, chrome
6260-()-()-()		\$4,302.	\$4,733.
6260-()-()-()		5,192.	5,624.
6260-()-()-()		2,919.	3,350.
6260-()-(GC, GB, GE)-()		8,119.	8,552.
6260-()-(NGC, NGE)-()		6,939.	7,371.
6260-()-GA-()		10,675.	11,108.
6272-()-()-()		6,179.	6,674.

C	623.
GL	n/c
CX	711.

Construction

 **KnollStudio 20-Day Program:**
The 6242 D'Urso Work Table with black legs and glides is available on the KnollStudio 20-Day program. All laminates in stock can be specified for the top finish. For specific information, consult pages 30-33.

Maintenance:
See pages 28-29.

Note:
The D'urso Tables with Laminate, Veneer or Granite tops and PVC edge are Greenguard certified.

Weight information above is based on work height tables. For weight information on low height tables, please contact your KnollStudio representative.

Top:
Laminate, Techgrain® and veneer or stone surface. Laminate, Techgrain® and veneer tops are 3-ply construction with medium density fiberboard core and plastic laminate backer (laminate tops) or paper backer (wood veneer tops). Laminate, Techgrain® and veneer tops have a black vinyl bullnose edge. $\frac{3}{4}$ " thick stone tops have an integral, hand-crafted bullnose edge.

Edge detail:
Laminate/Techgrain/wood tops

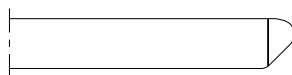

Stone tops:

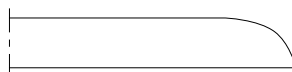

Base:
Racetrack-shaped steel legs with painted or polished chrome finish.

Glides:
Black nylon.

Casters:
3" single, black hard-rubber wheel. Polished chrome wheel housings with black or medium metallic grey legs. Black housings with polished chrome and red leg. Locking caster housings always polished chrome.

Wood tables with casters are weighted with steel plates to ensure stability. Plates are painted and secured under table top.

Please note: Casters cannot be retrofitted to tables with glides.

Joseph Paul D'Urso Racetrack Work Tables

Designer(s):
Joseph Paul D'Urso, 1980

Award(s):
Design Center Stuttgart Award, W. Germany, 1983; Federal Award for Industrial Design, W. Germany, 1983



description

6472 Racetrack table, small

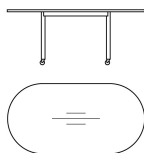

	w between legs	d between legs	w	d	h	weight	top
	32 3/4"	20 3/8"	72"	36"	27 1/2"	144 lbs.	laminata
	32 3/4"	20 3/8"	72"	36"	27 1/2"	141 lbs.	figured techgrain®
	32 3/4"	20 3/8"	72"	36"	27 1/2"	141 lbs.	natural veneer
	32 1/4"	20 3/8"	72"	36"	27 1/2"	200 lbs.	natural marble
	32 3/4"	20 3/8"	72"	36"	27 1/2"	200 lbs.	coated marble
	32 3/4"	20 3/8"	72"	36"	27 1/2"	232 lbs.	granite

6484 Racetrack table, medium

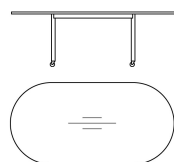

	38 3/4"	20 3/8"	84"	42"	27 1/2"	162 lbs.	laminata
	38 3/4"	20 3/8"	84"	42"	27 1/2"	159 lbs.	figured techgrain®
	38 3/4"	20 3/8"	84"	42"	27 1/2"	159 lbs.	natural veneer
	38 3/4"	20 3/8"	84"	42"	27 1/2"	294 lbs.	natural marble
	38 3/4"	20 3/8"	84"	42"	27 1/2"	294 lbs.	coated marble
	38 3/4"	20 3/8"	84"	42"	27 1/2"	338 lbs.	granite

6496 Racetrack table, large

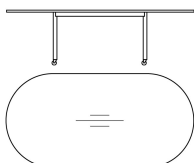

	44 3/4"	22 1/2"	96"	48"	27 1/2"	177 lbs.	laminata
	44 3/4"	22 1/2"	96"	48"	27 1/2"	173 lbs.	figured techgrain®
	44 3/4"	22 1/2"	96"	48"	27 1/2"	173 lbs.	natural veneer
	44 3/4"	22 1/2"	96"	48"	27 1/2"	377 lbs.	natural marble
	44 3/4"	22 1/2"	96"	48"	27 1/2"	377 lbs.	coated marble
	44 3/4"	22 1/2"	96"	48"	27 1/2"	434 lbs.	granite

GL Glides

C Casters

CX Locking casters

Order Code





<i>Example:</i>	6472-GL-GA-C
6472	72" x 36" racetrack table
GL	Glides
GA	Granite
C	Polished Chrome

Specify:

1. Pattern number
2. Specify L for low height tables
3. Glides/casters selection
4. Top finish selection
5. Leg finish selection

Ordering Information

Laminate top finishes:

-  Bright White (suffix 118)
-  Fog (suffix 128)
-  Jet Black (suffix 111)
-  Light Grey (suffix L)
-  Pumice (suffix 119)

Figured Techgrain top finishes:

- American Cherry (suffix P)
- Cherry (suffix R)
- Maple (suffix M)
- Medium Red Mahogany (suffix X)

Natural veneer top finishes:

- American Cherry (suffix X)
- Maple (suffix K)

Natural marble top finishes:

- Carrara: white-grey (suffix NGC)
- Emperador Dark: dark brown (suffix NGE)

Coated marble top finishes:

- Carrara: white-grey (suffix GC)
- Emperador Dark: dark brown (suffix GE)
- Empire Beige: beige (suffix GB)

Granite top finish:

- Black Andes: black (suffix GA)

Leg finishes:

-  Jet Black (suffix 111)
- Medium Metallic Grey (suffix 612)
- Polished Chrome (suffix C)
- Red (suffix RD)

Glides/casters:

- Casters (suffix C)
-  Glides, standard option (suffix GL)
- Locking casters (suffix CX)

Casters not available on stone racetrack tables.

 *KnollStudio 20-Day Program:*

The 6472 D'Urso Table with black legs and glides is available on the KnollStudio 20-Day program. All laminates in stock can be specified for top finish. For specific information, consult pages 30-33.

pattern no.	upcharge	base painted	base chrome
6472-(-)(-)(-)		\$3,301.	\$3,733.
6472-(-)(-)(-)		4,631.	5,060.
6472-(-)(-)(-)		5,306.	5,736.
6472-(-)(NGC, NGE)-()		6,615.	7,044.
6472-(-)(GC, GB, GE)-()		7,698.	8,130.
6472-(-)GA-()		10,721.	11,151.
6484-(-)(-)(-)		3,542.	3,973.
6484-(-)(-)(-)		4,910.	5,342.
6484-(-)(-)(-)		5,928.	6,359.
6484-(-)(NGC, NGE)-()		8,912.	9,343.
6484-(-)(GC, GB, GE)-()		10,355.	10,787.
6484-(-)GA-()		12,389.	12,821.
6496-(-)(-)(-)		3,639.	4,067.
6496-(-)(-)(-)		5,192.	5,622.
6496-(-)(-)(-)		6,490.	6,921.
6496-(-)(NGC, NGE)-()		11,178.	11,607.
6496-(-)(GC, GB, GE)-()		13,136.	13,565.
6496-(-)GA-()		14,896.	15,326.
GL	n/c		
C	623.		
CX	711.		

Construction

Maintenance:
See pages 28-29.

Note:
The D'urso Tables with Laminate, Veneer or Granite tops and PVC edge are Greenguard certified.

Weight information above is based on work height tables. For weight information on low height tables, please contact your KnollStudio representative.

Top:
Laminate, Techgrain® and veneer or stone surface. Laminate, Techgrain® and veneer tops are 3-ply construction with medium density fiberboard core and plastic laminate backer (laminate tops) or paper backer (wood veneer tops). Laminate, Techgrain® and veneer tops have a black vinyl bullnose edge. Wood tops are longitudinal veneered. 3/4" thick stone tops have an integral, hand-crafted bullnose edge.

Edge detail:
Laminate/Techgrain/wood tops:



Stone tops:



Base:
Racetrack-shaped steel legs with painted or polished chrome finish.



Glides:
Black nylon.

Casters:
3" single, black hard-rubber wheel. Polished chrome wheel housings with black or medium metallic grey legs. Black housings with polished chrome and red leg. Locking caster housings always polished chrome. Not available on stone racetrack tables.

Wood tables with casters are weighted with steel plates to ensure stability. Plates are painted and secured under table top.

Please note: Casters cannot be retrofitted to tables with glides.

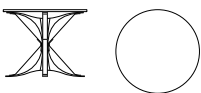
Frank Gehry Face Off Cafe Table

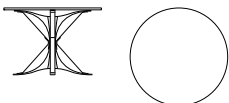
	description	w	d	h	weight	top	base
<i>Designer(s):</i> Frank Gehry, 1990	95T-36 Face Off 36" café table 	36"		28 3/4"	10 lbs.	glass	clear maple
		36"		28 3/4"	10 lbs.	white laminate	clear maple
	95T-40 Face Off 40" café table 	40"		28 3/4"	10 lbs.	glass	clear maple
		40"		28 3/4"	10 lbs.	white laminate	clear maple

Order Code

<i>Example:</i>	95T-36-G2-GC
95T-36	36" Face Off table
G2	Clear Glass
GC	Clear Maple

Note:
The Gehry tables are part of a collection. Please refer to Gehry side chairs and lounge seating starting on page 120.

Specify:

1. Pattern number
2. Top finish selection

Ordering Information

Glass top finish:
Clear Glass (suffix G2)

Laminate top finish :
White (suffix W)

Maple Base finish:
Clear (suffix GC)

Shipping note:
Tops ship separately.

Signature:
The underside of each piece in the Gehry Collection is embossed with Frank Gehry's signature and the Knoll logo.

Maintenance:
See pages 28-29.

Construction

Face Off Cafe Table tops:
1/2" thick tempered clear glass with polished edge; 3/8" thick textured laminate top with clear solid edgeband. Four bolts attach table top to base.

Face Off Cafe Table base:
Constructed of hard white maple veneers in 2" wide, 1/32" thick strips. Laminated to 7-ply thickness with high-bonding urea glue. All wood grains run in the same direction for resilience. State-of-the-art thermoset assembly glue provides structural rigidity without the need for metal connectors. Solid maple center column prevents cracking. Arched base design allows ample leg room.

Glides:
Clear plastic with a matte frost finish.



pattern no.

95T-36-G2-GC	\$4,470.
95T-36-W-GC	5,299.

95T-40-G2-GC	5,379.
95T-40-W-GC	6,203.

Alexander Girard

Coffee Table

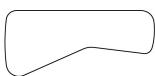
	description	w	d	h	weight
<i>Designer(s):</i> Alexander Girard, 1948 	108 Coffee Table  	59"	26"	16"	23 lbs.
		59"	26"	16"	23 lbs.

Order Code

Example: **108-LWA-111**

108 Coffee Table

LWA Light Walnut

111 Jet Black

Specify:

1. Pattern number
2. Top finish delection
3. Leg finish selection

Ordering Information

Top Finishes:

Ebonized Walnut (suffix D)

Light Walnut (suffix LWA)

Maple (suffix K)

Medium Cherry (suffix V319)

Leg Finish:

Jet Black (suffix 111)

Construction

Top:

Top is $\frac{3}{4}$ " baltic birch core with either plain slice bookmatch maple, cherry or ebonized veneer. Top has a 45° beveled edge.

Legs:

Cold-roll steel tubes with metal weldment in black powder coat.

Maintenance:

See pages 28-29.

pattern no.

108-(LWA, D, V319)-111	\$1,501.
108-KC-111	1,919.

Florence Knoll

Oval Table Desks

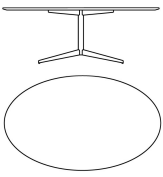
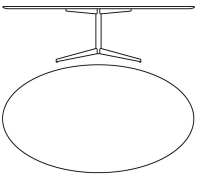
	description	w	d	h	weight	top	
<p><i>Designer(s):</i> Florence Knoll, 1961</p> <p><i>Award(s):</i> Design Center Stuttgart Award, 1969-70</p> 	<p>2480D Oval table desk</p> 	78"	47 3/4"	27 1/2"	313 lbs.	natural marble	
		78"	47 3/4"	28"	185 lbs.	white laminate	
		78"	47 3/4"	28"	174 lbs.	natural oak	
		78"	47 3/4"	27 1/2"	313 lbs.	coated marble	
		78"	47 3/4"	28"	174 lbs.	mahogany	
		78"	47 3/4"	28"	174 lbs.	ebonized oak	
		78"	47 3/4"	27 1/2"	313 lbs.	coated marble	
		78"	47 3/4"	28"	174 lbs.	pearwood	
		78"	47 3/4"	27 1/2"	313 lbs.	coated marble	
		78"	47 3/4"	27 1/2"	313 lbs.	coated marble	
		<p>2481D Oval table desk</p> 	96"	54"	27 1/2"	402 lbs.	natural marble
			96"	54"	28"	223 lbs.	white laminate
			96"	54"	27 1/2"	402 lbs.	coated marble
			96"	54"	28"	207 lbs.	natural oak
96"	54"		28"	207 lbs.	mahogany		
96"	54"		28"	207 lbs.	ebonized oak		
96"	54"		28"	207 lbs.	pearwood		
96"	54"		27 1/2"	402 lbs.	coated marble		
96"	54"		27 1/2"	402 lbs.	coated marble		
96"	54"		27 1/2"	402 lbs.	coated marble		

Order Code

<i>Example:</i>	2480D-CO-MC
2480D	Florence Knoll oval table desk
CO	Satin Chrome
MC	Calacatta Marble

Note:

Florence Knoll table desks are part of a collection. Please refer to Florence Knoll lounge seating on page 128 and credenzas, conference and low tables on the following pages.

Specify:

1. Pattern number
2. Base finish option
3. Top finish selection

Ordering Information

Base finishes:

Polished Chrome (suffix C)
Satin Chrome (suffix CO)

Laminate top finish:

White Laminate (suffix F2)

Veneer top finishes:

Ebonized Oak (suffix E)
Natural Oak (suffix O)
Medium Brown Mahogany (suffix M7)
Medium Red Mahogany (suffix M9)
Pearwood (suffix P)

Polished Coated marble top finishes:

Arabescato: white-grey (suffix MA)
Calacatta: white-grey/beige (suffix MC)
Carrara: white-grey (suffix GC)
Empire Beige: beige (suffix GB)
Emperador Dark: dark brown (suffix GE)
Grey Marble: light grey (suffix GG)
Nero Marquina: black (suffix MN)
Verde Alpi: green (suffix MV)

Satin Coated marble top finishes:

Arabescato: white-grey (suffix MAS)
Calacatta: white-grey/beige (suffix MCS)
Carrara: white-grey (suffix GCS)
Emperador Dark: dark brown (suffix GES)
Empire Beige: beige (suffix GBS)
Grey Marble: light grey (suffix GGS)
Nero Marquina: black (suffix MNS)
Verde Alpi: green (suffix MVS)

Natural marble top finishes:

Carrara: white-grey (suffix NGC)
Emperador Dark: dark brown (suffix NGE)

Maintenance:

See pages 28-29.

Note:

The KnollStudio logo and signature of Florence Knoll are stamped into the base of the table.

The Florence Knoll Oval Table Desk is Greenguard certified.

pattern no.	polished chrome base (C)	satin chrome base (CO)
2480D-(-)(NGC, NGE)	\$9,087.	\$9,485.
2480D-(-)-F2	9,278.	9,680.
2480D-(-)-O	10,293.	10,692.
2480D-(-)(GC, GCS, GE, GES, GB, GBS)	10,433.	10,834.
2480D-(-)(M7, M9)	10,752.	11,149.
2480D-(-)-E	11,203.	11,603.
2480D-(-)(MN, MNS, MA, MAS, GG, GGS)	12,082.	12,479.
2480D-(-)-P	12,327.	12,727.
2480D-(-)(MC, MCS)	12,806.	13,206.
2480D-(-)(MV, MVS)	15,715.	16,112.
2481D-(-)(NGC, NGE)	11,013.	11,409.
2481D-(-)-F2	12,806.	13,204.
2481D-(-)(GC, GCS, GE, GES, GB, GBS)	12,887.	13,286.
2481D-(-)-O	14,031.	14,427.
2481D-(-)(M7, M9)	14,484.	14,880.
2481D-(-)-E	14,940.	15,338.
2481D-(-)-P	16,438.	16,833.
2481D-(-)(MN, MNS, MA, MAS, GG, GGS)	16,640.	17,038.
2481D-(-)(MC, MCS)	17,639.	18,034.
2481D-(-)(MV, MVS)	21,577.	21,975.

Construction

Base:

Frame and legs heavy gauge welded steel. Post and four-star legs in polished chrome finish. Optional satin chrome finish. 78" and 96" tables use the same base.

Top:

Satin finish smooth laminate, wood veneer, or marble with bevel-edge. Laminate tops are 1 1/4" thick and veneer tops are 1 7/16" thick. Marble is 3/4" thick. Marble coated with transparent polyester to help eliminate use-associated stains.

Base footprint dimensions:

Base dimensions for the 2480D and 2481D are 42 7/8" w x 27 7/8" d. Base dimensions for the 2482T are 28 7/8" w x 28 3/8" d.

Glides:

Adjustable steel glides with a chrome finish.

Note:

Marbles with a coating will yellow over time.

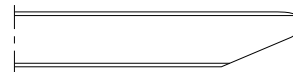

Laminate edge detail:

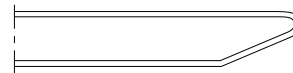

Marble edge detail:

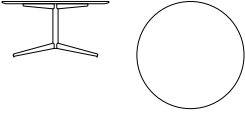

Florence Knoll Round Table Desk

	description	w	d	h	weight	top
<i>Designer(s):</i> Florence Knoll, 1961	2482T Round table desk 	54"		28"	142 lbs.	white laminate
		54"		27 1/2"	241 lbs.	natural marble
<i>Award(s):</i> Design Center Stuttgart Award, 1969-70		54"		27 1/2"	241 lbs.	coated marble
		54"		28"	134 lbs.	natural oak
		54"		28"	134 lbs.	mahogany
		54"		28"	134 lbs.	ebonized oak
		54"		27 1/2"	241 lbs.	coated marble
		54"		28"	134 lbs.	pearwood
		54"		27 1/2"	241 lbs.	coated marble
		54"		27 1/2"	241 lbs.	coated marble

Order Code

<i>Example:</i>	2482T-C-NGC
2482T	Florence Knoll round table desk
C	Polished Chrome
NGC	Carrara Marble

Note:

Florence Knoll table desks are part of a collection. Please refer to Florence Knoll lounge seating on page 128 and credenzas, conference and low tables on the following pages.

Specify:

1. Pattern number
2. Base finish option
3. Top finish selection

Ordering Information

Base finishes:

Polished Chrome (suffix C)
Satin Chrome (suffix CO)

Laminate top finish:

White Laminate (suffix F2)

Veneer top finishes:

Ebonized Oak (suffix E)
Natural Oak (suffix O)
Medium Brown Mahogany (suffix M7)
Medium Red Mahogany (suffix M9)
Pearwood (suffix P)

Polished Coated marble top finishes:

Arabescato: white-grey (suffix MA)
Calacatta: white-grey/beige (suffix MC)
Carrara: white-grey (suffix GC)
Empire Beige: beige (suffix GB)
Emperador Dark: dark brown (suffix GE)
Grey Marble: light grey (suffix GG)
Nero Marquina: black (suffix MN)
Verde Alpi: green (suffix MV)

Satin Coated marble top finishes:

Arabescato: white-grey (suffix MAS)
Calacatta: white-grey/beige (suffix MCS)
Carrara: white-grey (suffix GCS)
Emperador Dark: dark brown (suffix GES)
Empire Beige: beige (suffix GBS)
Grey Marble: light grey (suffix GGS)
Nero Marquina: black (suffix MNS)
Verde Alpi: green (suffix MVS)

Natural marble top finishes:

Carrara: white-grey (suffix NGC)
Emperador Dark: dark brown (suffix NGE)

Maintenance:

See pages 28-29.

Note:

The KnollStudio logo and signature of Florence Knoll are stamped into the base of the table.

The Florence Knoll Round Table Desk is Greenguard certified.

pattern no.	polished chrome base (C)	satin chrome base (CO)
2482T-()-F2	\$7,393.	\$7,850.
2482T-()-(NGC, NGE)	8,052.	8,507.
2482T-()-(GC, GCS, GE, GES, GB, GBS)	9,015.	9,469.
2482T-()-O	10,103.	10,559.
2482T-()-(M7,M9)	10,533.	10,988.
2482T-()-E	10,965.	11,422.
2482T-()-(MN, MNS, MA, MAS, GG, GGS)	12,008.	12,463.
2482T-()-P	12,062.	12,519.
2482T-()-(MC, MCS)	12,609.	13,063.
2482T-()-(MV, MVS)	15,630.	16,084.

Construction

Base:

Frame and legs heavy gauge welded steel. Post and four-star legs in polished chrome finish. Optional satin chrome finish.

Top:

Satin finish smooth laminate, wood veneer, or marble with bevel-edge. Laminate tops are 1 1/4" thick and veneer tops are 1 7/16" thick. Marble is 3/4" thick. Marble coated with transparent polyester to help eliminate use-associated stains.

Glides:

Adjustable steel glides with a chrome finish.

Base footprint dimensions:

Base dimensions for the 2480D and 2481D are 42 7/8" w x 27 7/8" d. Base dimensions for the 2482T are 28 7/8" w x 28 3/8" d.

Note:

Marbles with a coating will yellow over time.

Laminate edge detail:

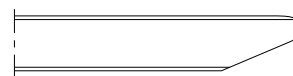

Marble edge detail:

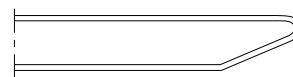

Florence Knoll *Executive Desk*

Designer(s):
Florence Knoll, 1954



description

2485D Rectangular desk with two pencil drawers

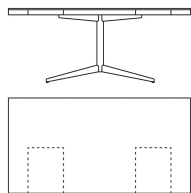

w

d

h

weight

top

72"

37 3/4"

29 1/4"

–

Mahogany/Oak/
Walnut

72"

37 3/4"

29 1/4"

–

Teak

72"

37 3/4"

29 1/4"

–

Rosewood

Order Code

<i>Example:</i>	2485D-C-LWA
2485D	Florence Knoll rectangular desk
C	Polished Chrome
LWA	Light Walnut

Specify:

1. Pattern number
2. Base finish option
3. Top finish selection

Ordering Information

Base finishes:
Polished Chrome (suffix C)
Satin Chrome (suffix CO)

Veneer top finishes:
Medium Brown Mahogany (suffix M7)
Ebonized Oak (suffix E)
Natural Oak (suffix O)
Light Walnut (suffix LWA)
Rosewood (suffix RO)
Teak (suffix TK)

Maintenance:
See pages 28-29.

Note:
The KnollStudio logo and signature of Florence Knoll are stamped into the base of the table.

Construction

Base:
Frame and legs heavy gauge welded steel. Post and four-star legs in polished chrome finish. Optional satin chrome finish.

Top:
Top and side are constructed of solid MDF core with veneer faces.

Drawers:
Two pencil drawers are constructed of solid maple lumber. Fronts are solid lumber with veneer face and edge. Pencil tray is solid lumber. Drawers on ball bearing metal slides.

pattern no.	polished chrome base (C)	satin chrome base (CO)
2485D-(C, CO)-()	\$10,635.	\$11,242.
2485D-(C, CO)-(TK)	13,581.	14,188.
2485D-(C, CO)-(RO)	15,321.	15,929.

Base footprint dimensions:

Base dimensions for the 2485D is 42³/₈"
w x 27³/₈" d.

Glides:

Adjustable steel glides with a chrome
finish.





Florence Knoll

Credenzas

Two Position Credenzas

Designer(s):
Florence Knoll, 1961



description	w	d	h	body
2541M Six box drawers (each with one removable partition) 	37 1/2"	18"	25 1/2"	natural oak
	37 1/2"	18"	25 1/2"	mahogany
	37 1/2"	18"	25 1/2"	ebonized oak
	37 1/2"	18"	25 1/2"	pearwood
2542M Four box drawers (each with one removable partition), one full extension file drawer with two metal bars for hanging files 	37 1/2"	18"	25 1/2"	natural oak
	37 1/2"	18"	25 1/2"	mahogany
	37 1/2"	18"	25 1/2"	ebonized oak
	37 1/2"	18"	25 1/2"	pearwood
2545M Two storage cabinets with two adjustable shelves for use in one or both cabinets 	37 1/2"	18"	25 1/2"	white lacquer
	37 1/2"	18"	25 1/2"	natural oak
	37 1/2"	18"	25 1/2"	mahogany
	37 1/2"	18"	25 1/2"	ebonized oak
	37 1/2"	18"	25 1/2"	pearwood
2546M Two box drawers (each with one removable partition), two full extension file drawers with two metal bars for hanging files 	37 1/2"	18"	25 1/2"	natural oak
	37 1/2"	18"	25 1/2"	mahogany
	37 1/2"	18"	25 1/2"	ebonized oak
	37 1/2"	18"	25 1/2"	pearwood

Order Code

<i>Example:</i>	2545M-C-M9-M9
2545M	Florence Knoll credenza, two position
C	Polished Chrome
M9	Medium Red Mahogany body
M9	Medium Red Mahogany top
2545x	Optional central locking system

Florence Knoll credenzas are part of a collection. Please refer to Florence Knoll lounge seating on page 128 and table desks, conference and low tables on beginning on page 324.

Ordering Information

Specify:

1. Pattern number
2. Base finish option
3. Body veneer selection
4. Top marble or wood selection
5. Optional central locking system (upcharge \$366)

Base finishes:

Polished Chrome (suffix C)
Satin Chrome (suffix CO)

Body and top veneers/lacquer:

Ebonized Oak (suffix E)
Medium Brown Mahogany (suffix M7)
Medium Red Mahogany (suffix M9)
Natural Oak (suffix O)
Pearwood (suffix P)
White Lacquer (on 2545M only: suffix 2)

Polished Coated marble top finishes:

Arabescato: white-grey (suffix MA)
Calacatta: white-grey/beige (suffix MC)
Carrara: white-grey (suffix GC)
Empire Beige: beige (suffix GB)
Emperador Dark: dark brown (suffix GE)
Grey Marble: light grey (suffix GG)
Nero Marquina: black (suffix MN)
Verde Alpi: green (suffix MV)

Satin Coated marble top finishes:

Arabescato: white-grey (suffix MAS)
Calacatta: white-grey/beige (suffix MCS)
Carrara: white-grey (suffix GCS)
Emperador Dark: dark brown (suffix GES)
Empire Beige: beige (suffix GBS)
Grey Marble: light grey (suffix GGS)
Nero Marquina: black (suffix MNS)
Verde Alpi: green (suffix MVS)

Natural marble top finishes:

Carrara: white-grey (suffix NGC)
Emperador Dark: dark brown (suffix NGE)

Central locking:

Optional central locking secures drawers and doors instantly with one single key lock located in credenza top (left front side). Add proper lock suffix to item number at an additional cost of \$366. See chart for ordering information.

Credenza Locking system pattern no.

2541M	2541X
2542M	2542X
2545M	2545X
2546M	2546X

Note:

KnollStudio logo and Florence Knoll's signature are stamped on each piece.

For weight information, please contact your KnollStudio representative.

Maintenance:

See pages 28-29.

pattern no.	(MN, MNS, MA, MAS, MC, MCS MV, MVS, GG, GGS)				(MN, MNS, MA, MAS, MC, MCS MV, MVS, GG, GGS)			
	wood top/ polished base	marble top/ polished base	(GC, GCS, GE, GES, GB, GBS) marble top/ polished base	(NGC, NGE) marble top/ polished base	wood top/ satin base	marble top/ satin base	(GC, GCS, GE, GES, GB, GBS) marble top/ satin base	(NGC, NGE) marble top/ satin base
2541M-(-)O-(-)(-)	\$10,081.	\$10,962.	\$10,962.	\$10,731.	\$10,226.	\$11,108.	\$11,108.	\$10,876.
2541M-(-)(M7, M9)-(-)(-)	10,693.	11,603.	11,603.	11,359.	10,837.	11,747.	11,747.	11,503.
2541M-(-)E-(-)(-)	11,346.	12,116.	12,116.	11,866.	11,491.	12,260.	12,260.	12,009.
2541M-(-)P-(-)(-)	13,327.	13,327.	13,327.	13,072.	13,470.	13,471.	13,471.	13,216.
2542M-(-)O-(-)(-)	9,726.	10,579.	10,579.	10,345.	9,867.	10,721.	10,721.	10,487.
2542M-(-)(M7, M9)-(-)(-)	10,194.	11,089.	11,089.	10,845.	10,336.	11,230.	11,230.	10,987.
2542M-(-)E-(-)(-)	10,730.	11,603.	11,603.	11,352.	10,871.	11,744.	11,744.	11,493.
2542M-(-)P-(-)(-)	12,763.	12,763.	12,763.	12,516.	12,904.	12,905.	12,905.	12,657.
2545M-(-)2-(-)(-)	n/a	8,666.	8,666.	8,373.	n/a	8,811.	8,811.	8,517.
2545M-(-)O-(-)(-)	6,394.	7,134.	7,134.	6,935.	6,538.	7,278.	7,278.	7,080.
2545M-(-)(M7, M9)-(-)(-)	6,868.	7,649.	7,649.	7,438.	7,013.	7,794.	7,794.	7,582.
2545M-(-)E-(-)(-)	7,377.	8,156.	8,156.	7,934.	7,522.	8,300.	8,300.	8,077.
2545M-(-)P-(-)(-)	8,971.	8,971.	8,971.	8,768.	9,114.	9,114.	9,114.	8,913.
2546M-(-)O-(-)(-)	9,547.	10,389.	10,389.	10,149.	9,688.	10,622.	10,622.	10,383.
2546M-(-)(M7, M9)-(-)(-)	9,953.	10,836.	10,836.	10,585.	10,093.	11,070.	11,070.	10,821.
2546M-(-)E-(-)(-)	10,425.	11,346.	11,346.	11,091.	10,566.	11,582.	11,582.	11,326.
2546M-(-)P-(-)(-)	12,484.	12,484.	12,484.	12,232.	12,624.	12,718.	12,718.	12,468.

Construction

Base:

Welded square steel tube in polished chrome finish. Optional satin chrome finish. Adjustable glides.

Body:

Wood veneer sides and matching back panel in oak, pearwood, or mahogany. Oak, mahogany and pearwood finished with transparent polyurethane coat. Only 2545M storage cabinet available in white lacquer.

Top:

3/4" thick marble coated with transparent polyester to help eliminate use-associated stains. Squared edge detail. 3/4" wood top matching body available. Wood tops finished with transparent polyurethane coat.

Note:

Marbles with a coating will yellow over time.

Front:

Drawer and door fronts in same wood veneers or lacquer finish as body. All have polished aluminum pulls, top flush mounted storage doors with magnetic closures. Location A storage hinges open from left. Location B storage hinges open from right. Other hinging available as special. Pull out drawers with smooth-glide extension slides. Drawer and storage have matching veneer inside.



Florence Knoll

Credenzas

Four Position Credenzas

Designer(s):
Florence Knoll, 1961

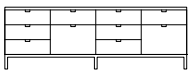
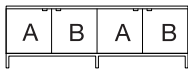
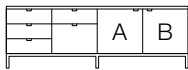
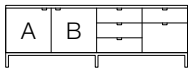

description	w	d	h	body
2543M Eight box drawers (each with one removable partition), two full-extension file drawers with two metal bars each for hanging files 	74 3/4"	18"	25 1/2"	natural oak
	74 3/4"	18"	25 1/2"	mahogany
	74 3/4"	18"	25 1/2"	ebonized oak
	74 3/4"	18"	25 1/2"	pearwood
2544M Four storage cabinets with four adjustable shelves for use in two or more of the cabinets 	74 3/4"	18"	25 1/2"	white lacquer
	74 3/4"	18"	25 1/2"	natural oak
	74 3/4"	18"	25 1/2"	mahogany
	74 3/4"	18"	25 1/2"	ebonized oak
2547M Four box drawers (each with one removable partition), one full-extension file drawer with two metal bars for hanging files. Two storage cabinets with two adjustable shelves for use in one or both cabinets 	74 3/4"	18"	25 1/2"	natural oak
	74 3/4"	18"	25 1/2"	mahogany
	74 3/4"	18"	25 1/2"	ebonized oak
	74 3/4"	18"	25 1/2"	pearwood
2548M Four box drawers (each with one removable partition), one full-extension file drawer with two metal bars, two storage cabinets with two adjustable shelves for use in one or both cabinets 	74 3/4"	18"	25 1/2"	natural oak
	74 3/4"	18"	25 1/2"	mahogany
	74 3/4"	18"	25 1/2"	ebonized oak
	74 3/4"	18"	25 1/2"	pearwood
2549M Four box drawers (each with one removable partition), four full-extension file drawers with two metal bars each for hanging files 	74 3/4"	18"	25 1/2"	natural oak
	74 3/4"	18"	25 1/2"	mahogany
	74 3/4"	18"	25 1/2"	ebonized oak
	74 3/4"	18"	25 1/2"	pearwood

Order Code

<i>Example:</i>	2543M-CO-P-MN
2543M	Florence Knoll credenza, four position
CO	Satin Chrome
P	Pearwood body
MN	Nero Marquina top
2543x	Optional locking system

Florence Knoll credenzas are part of a collection. Please refer to Florence Knoll lounge seating on page 128 and table desks, conference and low tables beginning on page 324.

Ordering Information

Specify:

1. Pattern number
2. Base finish option
3. Body veneer selection
4. Top marble or wood selection
5. Optional central locking system (upcharge \$733)

Base finishes:

Polished Chrome (suffix C)
Satin Chrome (suffix CO)

Body and top veneers/lacquer:

Ebonized Oak (suffix E)
Medium Brown Mahogany (suffix M7)
Medium Red Mahogany (suffix M9)
Natural Oak (suffix O)
Pearwood (suffix P)
White Lacquer (on 2544M only: suffix 2)

Polished Coated marble top finishes:

Arabescato: white-grey (suffix MA)
Calacatta: white-grey/beige (suffix MC)
Carrara: white-grey (suffix GC)
Empire Beige: beige (suffix GB)

Emperador Dark: dark brown (suffix GE)
Grey Marble: light grey (suffix GG)
Nero Marquina: black (suffix MN)
Verde Alpi: green (suffix MV)

Satin Coated marble top finishes:

Arabescato: white-grey (suffix MAS)
Calacatta: white-grey/beige (suffix MCS)
Carrara: white-grey (suffix GCS)
Emperador Dark: dark brown (suffix GES)
Empire Beige: beige (suffix GBS)
Grey Marble: light grey (suffix GGS)
Nero Marquina: black (suffix MNS)
Verde Alpi: green (suffix MVS)

Natural marble top finishes:

Carrara: white-grey (suffix NGC)
Emperador Dark: dark brown (suffix NGE)

Central locking:

Optional central locking secures drawers and doors instantly with one single key lock located in credenza top (left front side). Add proper lock suffix to item number at an additional cost of \$733. See chart below for ordering information.

Credenza pattern	Central locking system pattern no.
2543M	2543X
2544M	2544X
2547M	2547X
2548M	2548X
2549M	2549X

Note:

KnollStudio logo and Florence Knoll's signature are stamped on each piece.

For weight information, please contact your KnollStudio representative.

Maintenance:

See pages 28-29.

pattern no.	(MN, MNS, MA, MAS, MC, MCS MV, MVS, GG, GGS)				(MN, MNS, MA, MAS, MC, MCS MV, MVS, GG, GGS)			
	wood top/ polished base	marble top/ polished base	(GC, GCS, GE, GES, GB, GBS) marble top/ polished base	(NGC, NGE) marble top/ polished base	wood top/ satin base	marble top/ satin base	(GC, GCS, GE, GES, GB, GBS) marble top/ satin base	(NGC, NGE) marble top/ satin base
2543M-(-)O-(-)(-)	\$19,387.	\$21,173.	\$21,173.	\$20,690.	\$19,623.	\$21,408.	\$21,408.	\$20,927.
2543M-(-)(M7,M9)-(-)(-)	20,600.	22,321.	22,321.	21,816.	20,834.	22,559.	22,559.	22,052.
2543M-(-)E-(-)(-)	21,670.	23,472.	23,472.	22,947.	21,904.	23,706.	23,706.	23,183.
2543M-(-)P-(-)(-)	25,819.	25,819.	25,819.	25,303.	26,055.	26,056.	26,056.	25,539.
2544M-(-)2-(-)(-)	n/a	17,259.	17,259.	16,638.	n/a	17,496.	17,496.	16,877.
2544M-(-)O-(-)(-)	12,646.	14,155.	14,155.	13,743.	12,883.	14,393.	14,393.	13,980.
2544M-(-)(M7,M9)-(-)(-)	13,464.	14,921.	14,921.	14,490.	13,702.	15,159.	15,159.	14,727.
2544M-(-)E-(-)(-)	14,166.	15,688.	15,688.	15,245.	14,402.	15,924.	15,924.	15,483.
2544M-(-)P-(-)(-)	17,259.	17,219.	17,219.	16,818.	17,496.	17,456.	17,456.	17,054.
2547M-(-)O-(-)(-)	16,018.	17,678.	17,678.	17,227.	16,252.	17,913.	17,913.	17,462.
2547M-(-)(M7,M9)-(-)(-)	16,970.	18,572.	18,572.	18,104.	17,207.	18,809.	18,809.	18,340.
2547M-(-)E-(-)(-)	17,803.	19,461.	19,461.	18,976.	18,037.	19,696.	19,696.	19,210.
2547M-(-)P-(-)(-)	21,414.	21,414.	21,414.	20,957.	21,651.	21,650.	21,650.	21,191.
2548M-(-)O-(-)(-)	16,018.	17,678.	17,678.	17,227.	16,252.	17,913.	17,913.	17,462.
2548M-(-)(M7,M9)-(-)(-)	16,970.	18,572.	18,572.	18,104.	17,207.	18,809.	18,809.	18,340.
2548M-(-)E-(-)(-)	17,803.	19,461.	19,461.	18,976.	18,037.	19,696.	19,696.	19,210.
2548M-(-)P-(-)(-)	21,414.	21,414.	21,414.	20,957.	21,651.	21,650.	21,650.	21,191.
2549M-(-)O-(-)(-)	18,671.	20,404.	20,404.	19,915.	18,908.	20,641.	20,641.	20,153.
2549M-(-)(M7,M9)-(-)(-)	19,886.	21,551.	21,551.	21,044.	20,123.	21,789.	21,789.	21,282.
2549M-(-)E-(-)(-)	20,954.	22,701.	22,701.	22,154.	21,190.	22,940.	22,940.	22,392.
2549M-(-)P-(-)(-)	25,104.	25,104.	25,104.	24,585.	25,341.	25,342.	25,342.	24,823.

Construction

<p>Base: Welded square steel tube in polished chrome finish. Optional satin chrome finish. Adjustable glides.</p> <p>Body: Wood veneer sides and matching back panel in oak, pearwood, or mahogany. Oak, mahogany and pearwood finished with transparent polyurethane coat. Only 2544M storage cabinet available in white lacquer.</p>	<p>Top: 3/4" thick marble coated with transparent polyester to help eliminate use-associated stains. Squared edge detail. 3/4" wood top matching body available. Wood tops finished with transparent polyurethane coat.</p> <p>Note: Marbles with a coating will yellow over time.</p>	<p>Front: Drawer and door fronts in same wood veneers or lacquer finish as body. All have polished aluminum pulls, top flush mounted storage doors with magnetic closures. Location A storage hinges open from left. Location B storage hinges open from right. Other hinges open from right. Other hinging available as special. Pull out drawers with smooth-glide extension slides. Drawer and storage have matching veneer inside.</p>
--	--	---

Florence Knoll

Coffee Tables

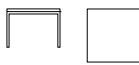
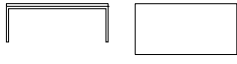
	description	w	d	h	weight	top	
<p><i>Designer(s):</i> Florence Knoll, 1954</p> <p><i>Award(s):</i> American Institute of Interior Designers First Award, USA, 1954</p> 	2510T Square coffee table 	23 1/2"	23 1/2"	17"	50 lbs.	clear glass	
		23 1/2"	23 1/2"	17"	50 lbs.	white or black glass	
			23 1/2"	23 1/2"	17"	65 lbs.	natural marble
			23 1/2"	23 1/2"	17"	65 lbs.	coated marble
			23 1/2"	23 1/2"	17"	33 lbs.	veneer
			23 1/2"	23 1/2"	17"	65 lbs.	coated marble
			23 1/2"	23 1/2"	17"	33 lbs.	pearwood
			23 1/2"	23 1/2"	17"	65 lbs.	coated marble
			23 1/2"	23 1/2"	17"	65 lbs.	coated marble
			23 1/2"	23 1/2"	17"	67 lbs.	granite
			23 1/2"	23 1/2"	17"	65 lbs.	natural marble
		2511T Rectangular coffee table 	45"	22 1/2"	17"	76 lbs.	clear glass
			45"	22 1/2"	17"	104 lbs.	natural marble
			45"	22 1/2"	17"	104 lbs.	coated marble
	45"		22 1/2"	17"	45 lbs.	veneer	
	45"		22 1/2"	17"	104 lbs.	coated marble	
	45"		22 1/2"	17"	45 lbs.	pearwood	
	45"		22 1/2"	17"	104 lbs.	coated marble	
	45"		22 1/2"	17"	104 lbs.	coated marble	
	45"		22 1/2"	17"	106 lbs.	granite	
	45"		22 1/2"	17"	104 lbs.	natural marble	

Order Code



<i>Example:</i>	2510T-C-G2
2510T	Florence Knoll square coffee table
C	Polished Chrome
G2	Clear glass

Note:
Florence Knoll coffee tables are part of a collection. Please refer to Florence Knoll lounge seating on page 128 and desks and credenzas beginning on page 324.

Specify:

1. Pattern number
2. Base finish option
3. Top selection

Ordering Information

Base finishes:
 Polished Chrome (suffix C)
 Satin Chrome (suffix CO)

Glass top finishes:
 Black Glass (suffix C1)
 Clear Glass (suffix G2)
 White Glass (suffix C2)

Veneer finishes:
 Ebonized Walnut (suffix D)
 Light Oak (suffix LO)
 Light Walnut (suffix LWA)
 Reff Dark Cherry (suffix V314)

Pearwood finish:
 Pearwood (suffix P)

Polished Coated marble top finishes:
 Arabescato: white-grey (suffix MA)
 Calacatta: white-grey/beige (suffix MC)
 Carrara: white-grey (suffix GC)
 Emperador Dark: dark brown (suffix GE)
 Empire Beige: beige (suffix GB)
 Grey Marble: light grey (suffix GG)
 Nero Marquina: black (suffix MN)
 Verdi Alpi: green (suffix MV)

Satin Coated marble top finishes:
 Arabescato: white-grey (suffix MAS)
 Calacatta: white-grey/beige (suffix MCS)
 Carrara: white-grey (suffix GCS)
 Emperador Dark: dark brown (suffix GES)
 Empire Beige: beige (suffix GBS)
 Grey Marble: light grey (suffix GCG)
 Nero Marquina: black (suffix MNS)
 Verde Alpi: green (suffix MVS)

Natural marble top finishes:
 Calacatta: white-grey/beige (suffix NC)
 Carrara: white-grey (suffix NGC)
 Emperador Dark: dark brown (suffix NGE)

Granite top finish:
 Black Andes: black (suffix GA)

 *KnollStudio 20-Day Program:*
 The Florence Knoll 2510T and 2511T tables in polished chrome finish and clear glass top are available on the KnollStudio 20-Day program. For specific information, consult pages 30-33.



Note:
 Wood finishes on Florence Knoll low tables differ from those on the table desk and credenzas.

Base:
 Polished chrome-plated or satin chrome-plated steel.

Maintenance:
 See pages 28-29.

Note:
 KnollStudio logo and signature of Florence Knoll are stamped into the base.

The Florence Knoll Coffee and End Tables in all finishes are Greenguard certified.

pattern no.	polished chrome (suffix C)	satin chrome (suffix CO)
2510T(-)-G2 	\$1,075.	\$1,159.
2510T(-)-C1, C2)	1,481.	1,563.
2510T(-)-(NGC, NGE)	1,878.	1,958.
2510T(-)-(MN, MNS, MA, MAS, GG, GGS)	1,976.	2,057.
2510T(-)-(LO, LWA, D, V314)	2,052.	2,133.
2510T(-)-(GC, GCS, GE, GES, GB, GBS)	2,070.	2,152.
2510T(-)-(P)	2,227.	2,308.
2510T(-)-(MC, MCS)	2,254.	2,336.
2510T(-)-(MV, MVS)	2,616.	2,697.
2510T(-)-(GA)	3,367.	3,449.
2510T(-)-(NC)	3,652.	3,734.
2511T(-)-G2 	1,488.	1,606.
2511T(-)-(NGC, NGE)	2,504.	2,621.
2511T(-)-(MN, MNS, MA, MAS, GG, GGS)	2,704.	2,820.
2511T(-)-(LO, LWA, D, V314)	2,724.	2,842.
2511T(-)-(GC, GCS, GE, GES, GB, GBS)	2,834.	2,951.
2511T(-)-(P)	2,966.	3,083.
2511T(-)-(MC, MCS)	3,085.	3,204.
2511T(-)-(MV, MVS)	3,645.	3,762.
2511T(-)-(GA)	4,509.	4,628.
2511T(-)-(NC)	5,190.	5,308.

Construction

Top:
5/8" thick polished plate glass or coated marble with transparent polyester to help eliminate use-associated stains. 3/4" thick natural marble and granite top with protective sealer.

Note:
Marbles with a coating will yellow over time.

Wood Top:
Tops are constructed of veneered medium density fiberboard with a cathedral grain pattern in various toned or stained finishes for light oak, light walnut, reff dark cherry and pearwood. Ebonized walnut features a black stain on walnut substrate. Tops are 3/4" thick. Base and Top ship seperately. Top is attached to base with wood screws that are enclosed in hardware packet.

Florence Knoll

End Tables

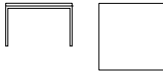
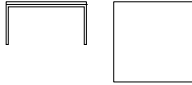
	description	w	d	h	weight	top	
Designer(s): Florence Knoll, 1954 Award(s): American Institute of Interior Designers First Award, USA, 1954 	2515T Square end table 	29 1/2"	29 1/2"	19"	71 lbs.	clear glass	
		29 1/2"	29 1/2"	19"	95 lbs.	natural marble	
		29 1/2"	29 1/2"	19"	95 lbs.	coated marble	
		29 1/2"	29 1/2"	19"	95 lbs.	coated marble	
		29 1/2"	29 1/2"	19"	44 lbs.	veneer	
		29 1/2"	29 1/2"	19"	44 lbs.	pearwood	
		29 1/2"	29 1/2"	19"	95 lbs.	coated marble	
		29 1/2"	29 1/2"	19"	95 lbs.	coated marble	
		29 1/2"	29 1/2"	19"	96 lbs.	granite	
		29 1/2"	29 1/2"	19"	95 lbs.	natural marble	
		2517T Square end table 	35 1/2"	35 1/2"	19"	93 lbs.	clear glass
			35 1/2"	35 1/2"	19"	128 lbs.	natural marble
35 1/2"	35 1/2"		19"	53 lbs.	veneer		
35 1/2"	35 1/2"		19"	128 lbs.	coated marble		
35 1/2"	35 1/2"		19"	53 lbs.	pearwood		
35 1/2"	35 1/2"		19"	128 lbs.	coated marble		
35 1/2"	35 1/2"		19"	128 lbs.	coated marble		
35 1/2"	35 1/2"		19"	128 lbs.	coated marble		
35 1/2"	35 1/2"		19"	131 lbs.	granite		
35 1/2"	35 1/2"		19"	128 lbs.	natural marble		

Order Code

Example:	2517T-CO-GS
2517T	Florence Knoll square end table
CO	Satin Chrome
GS	Cedar Stone

Note:
Florence Knoll end tables are part of a collection. Please refer to Florence Knoll lounge seating on page 128 and desks and credenzas beginning on page 324.

Specify:

1. Pattern number
2. Base finish option
3. Top selection

Ordering Information

Base finishes:
Polished Chrome (suffix C)
Satin Chrome (suffix CO)

Glass top finishes:
Clear Glass (suffix G2)

Veneer finishes:
Ebonized Walnut (suffix D)
Light Oak (suffix LO)
Light Walnut (suffix LWA)
Reff Dark Cherry (suffix V314)

Pearwood finish:
Pearwood (suffix P)

Polished Coated marble top finishes:
Arabescato: white-grey (suffix MA)
Calacatta: white-grey/beige (suffix MC)
Carrara: white-grey (suffix GC)
Emperador Dark: dark brown (suffix GE)
Empire Beige: beige (suffix GB)
Grey Marble: light grey (suffix GG)
Nero Marquina: black (suffix MN)
Verdi Alpi: green (suffix MV)

Satin Coated marble top finishes:
Arabescato: white-grey (suffix MAS)
Calacatta: white-grey/beige (suffix MCS)
Carrara: white-grey (suffix GCS)
Emperador Dark: dark brown (suffix GES)
Empire Beige: beige (suffix GBS)
Grey Marble: light grey (suffix GGS)
Nero Marquina: black (suffix MNS)
Verde Alpi: green (suffix MVS)

Natural marble top finishes:
Calacatta: white-grey/beige (suffix NC)
Carrara: white-grey (suffix NGC)
Emperador Dark: dark brown (suffix NGE)

Granite top finish:
Black Andes: black (suffix GA)

Note:
Wood finishes on Florence Knoll low tables differ from those on the table desk and credenzas.

Base:
Polished chrome-plated or satin chrome-plated steel.

Maintenance:
See pages 28-29.

Note:
KnollStudio logo and signature of Florence Knoll are stamped into the base.

The Florence Knoll Coffee and End Tables in all finishes are Greenguard certified.

pattern no.	polished chrome (suffix C)	satin chrome (suffix CO)
2515T(-)G2	\$1,437.	\$1,520.
2515T(-)(NGC, NGE)	2,211.	2,297.
2515T(-)(MN, MNS, MA, MAS, GG, GGS)	2,365.	2,450.
2515T(-)(GC, GCS, GE, GES, GB, GBS)	2,478.	2,565.
2515T(-)(LO, LWA, D, V314)	2,814.	2,899.
2515T(-)(P)	3,055.	3,140.
2515T(-)(MC, MCS)	3,242.	3,327.
2515T(-)(MV, MVS)	3,288.	3,372.
2515T(-)(GA)	4,314.	4,398.
2515T(-)(NC)	4,814.	4,890.
2517T(-)G2	1,671.	1,787.
2517T(-)(NGC, NGE)	2,876.	2,994.
2517T(-)(LO, LWA, D, V314)	2,931.	3,049.
2517T(-)(MN, MNS, MA, MAS, GG, GGS)	3,151.	3,267.
2517T(-)(P)	3,174.	3,291.
2517T(-)(GC, GCS, GE, GES, GB, GBS)	3,301.	3,419.
2517T(-)(MV, MVS)	4,116.	4,233.
2517T(-)(MC, MCS)	4,316.	4,434.
2517T(-)(GA)	5,140.	5,258.
2517T(-)(NC)	5,861.	5,978.

Construction









Top:
 $\frac{3}{8}$ " thick polished plate glass or coated marble with transparent polyester to help eliminate use-associated stains. $\frac{3}{4}$ " thick natural marble and granite top with protective sealer.

Note:
 Marbles with a coating will yellow over time.

Wood Top:
 Tops are constructed of veneered medium density fiberboard with a cathedral grain pattern in various toned or stained finishes for light oak, light walnut, reff dark cherry and pearwood. Ebonyed walnut features a black stain on walnut substrate. Tops are $\frac{3}{8}$ " thick. Tops contain threaded inserts and attach to base with screws.

Marc Krusin

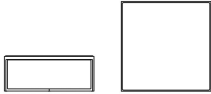
Occasional Tables

	description	w	d	h	base
<p>Designer(s): Marc Krusin, 2012</p>  	MK11 Square side table	18"	18"	18"	Ash, Beech & Oak
		18"	18"	18"	Walnut
	MK12 Square side table	18"	18"	22"	Ash, Beech & Oak
		18"	18"	22"	Walnut
	MK13 Square end table	24"	24"	14"	Ash, Beech & Oak
		24"	24"	14"	Walnut
	MK14 Square coffee table	36"	36"	10"	Ash, Beech & Oak
		36"	36"	10"	Walnut
	MK15 Square coffee table	36"	36"	14"	Ash, Beech & Oak
		36"	36"	14"	Walnut
	MK16 Rectangular coffee table	40"	24"	14"	Ash, Beech & Oak
		40"	24"	14"	Walnut

Order Code

<i>Example:</i>	MK13-G2-A101
MK13	Square End Table
G2	Clear Glass
A101	White ash base

Note:

When specifying veneer tops, the base finish matches top. Contrasting top and base finish is not a standard option

Specify:

1. Pattern number
2. Top Finish
3. Base Finish

Ordering Information

Base Finishes:

Ash:
White Ash, suffix A101

Oak:
Natural Oak (suffix ON)
Ebonized Oak (suffix OE)
Fumed Oak (suffix OF)

Walnut:
American Walnut (suffix AW)

Beech:
Beech (suffix B311)
Bronzed Cherry (suffix B12A)
Burnt Walnut (suffix B313)
Deep Red Mahogany (suffix B328)
Ebonized (suffix BE)
Light Cherry (suffix B315)
Light Walnut (suffix B411)
Medium Cherry (suffix B319)
Medium Red Mahogany (suffix BR)
Medium Walnut (suffix B323)
Natural Beech (suffix BN)

Top Finishes:

Laminate:
Bright White (suffix 118)

Glass:
Clear Glass (suffix G2)

Ash:
White Ash (suffix A101)

Oak:
Natural Oak (suffix ON)
Ebonized Oak (suffix OE)
Fumed Oak (suffix OF)

Walnut:
American Walnut (suffix AW)

Veneer:

Beech:
Beech (suffix B311)
Bronzed Cherry (suffix B312A)
Burnt Walnut (suffix B313)
Deep Red Mahogany (suffix B328)
Ebonized (suffix BE)
Light Cherry (suffix B315)
Medium Cherry (suffix B319)
Medium Red Mahogany (suffix BR)
Medium Walnut (suffix B323)
Natural Beech (suffix BN)

pattern no	glass & laminare tops	veneer top	leather	GE, GES	MA, MAS	MC, MCS	engineered stone (VB)
MK11-()-()	\$1,098.	\$1,650.	\$1,859.	\$2,019.	\$2,119.	\$2,334.	\$1,953.
MK11-()-AW	1,231.	1,870.	2,024.	2,185.	2,285.	2,494.	2,124.
MK12-()-()	1,108.	1,660.	1,870.	2,030.	2,129.	2,344.	1,976.
MK12-()-AW	1,246.	1,893.	2,036.	2,206.	2,306.	2,520.	2,152.
MK13-()-()	1,351.	1,771.	2,119.	2,487.	2,615.	2,979.	2,665.
MK13-()-AW	1,572.	2,058.	2,395.	2,763.	2,891.	3,255.	2,941.
MK14-()-()	1,838.	2,058.	3,238.	3,646.	4,132.	4,739.	4,744.
MK14-()-AW	2,019.	2,339.	3,470.	3,879.	4,363.	4,976.	4,982.
MK15-()-()	1,838.	2,058.	3,238.	3,646.	4,132.	4,739.	4,744.
MK15-()-AW	2,019.	2,339.	3,470.	3,879.	4,363.	4,976.	4,982.
MK16-()-()	1,963.	2,541.	3,459.	3,968.	4,764.	5,607.	3,639.
MK16-()-AW	2,042.	2,625.	3,543.	4,069.	4,865.	5,707.	3,735.

Construction

Leather:

Spinneybeck Riva:

Anata Beccorosso (suffix RA1808)
 Aquila de Mare (suffix RA1813)
 Beccaccia de Mare (suffix RA1815)
 Black (suffix RABLK)
 Cavaliere d'Italia (suffix RA1804)
 Pagliarolo (suffix RA1809)
 Spatola (suffix RA1806)
 *CFA waived for this product line

Coated Marble (polished, satin):

Arabescato (suffix MA, MAS)
 Calacatta (suffix MC, MCS)
 Emperador Dark (suffix GE, GES)

Engineered Stone:

Vetro Bianco (VB)

Frame:

Select American and European hard wood frames. Dowel and mortise and tenon construction.

Marble and Glass Tops:

Inset 3/4" thick coated marbles in polished or satin polyester coating and clear tempered glass with radius corners. Tops rest within the frame.

Veneer and Laminate Tops:

Constructed with MDF core with solid lumber edges. Laminate has painted filled edge. Face and back are veneer or laminate. Inset tops have threaded inserts to attach to frame.

Leather Tops:

Constructed with MDF core wrapped in select Riva leather in various colors.



Finish:

Beech, Catalyzed lacquer protective coating. Hand applied final wax coating. Ash, Oak, and Walnut with low sheen urethane protective coating. Hand applied final wax coating. Conversion varnish top coat.

Glides:

Felt glides included with all bases for use on hard floor surfaces.

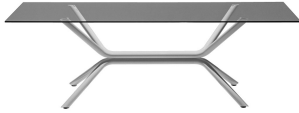
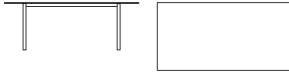
Ross Lovegrove Table Desks

	description	w	d	h	weight	top
Designer(s): Ross Lovegrove, 2007 Award(s): Good Design Award, 2007 	RL1 Rectangular table 	78 3/4"	39 7/8"	28"	154 lbs.	laminata
		78 3/4"	39 7/8"	28"	213 lbs.	bronze and starphire glass
	RL2 Rectangular Table 	78 3/4"	39 7/8"	28"	160 lbs.	laminata
		78 3/4"	39 7/8"	28"	220 lbs.	bronze and starphire glass
		78 3/4"	39 7/8"	28"	220 lbs.	painted, etched glass
	RL3 Rectangular Table 	78 3/4"	39 7/8"	28"	218 lbs.	starphire glass

Order Code

<i>Example:</i>	RL2-PL3-118
RL2	Ross Lovegrove Rectangular table
PL3	Panelite, red
118	White

Specify:

1. Pattern number
2. Top finish selection
3. Base finish selection

Ordering Information

Glass finishes:
 Bronze glass (suffix BRG)
 Painted green, acid etched glass (suffix GA1)
 Painted blue, acid etched glass (suffix GA2)
 Painted red, acid etched glass (suffix GA3)
 Starphire glass (suffix SFG)

Laminate finishes:
 White (suffix 118)

Base finish:
 Metallic Bronze (suffix BRM)
 Multi-colored (suffix MTC)
 Robin's Egg Blue (suffix REB)
 Silver (suffix SLV)
 White (suffix 118)

Maintenance:
 See pages 28-29.

Note:
 Multi-color base available on RL3 only. Base consists of robin's egg blue, rust, yellow and orange. Top and base are shipped in separate packages. Bases have nameplate with designer's signature. **Not suitable for outdoor use.**

The Ross Lovegrove Table Desk is Greenguard certified.

Construction

Glass Tops:
Starphire™ Glass Top:
 Tempered Starphire glass is more clear and luminous than regular glass. The low iron content gives glass a crystal quality. 1/8" bevel edge has an exceptionally clear character.

Bronze Glass:
 Tempered bronze colored glass; 1/2" thick with beveled edge and polished edge.

Painted Acid Etched Glass:
 Tempered acid etched top surface with painted underside.

Please note all glass tops have shaped corners. The RL1 features a 7" radius corners and the RL2 and RL3 feature a 3" radius corner. All glass tops are 1/2" thick with a beveled and polished edge.

pattern no.

RL1-118-()	\$4,716.
RL1-(BRG, SFG)-()	5,899.

RL2-118-()	4,156.
RL2-(BRG, SFG)-()	5,336.
RL2-(GA1, GA2, GA3)-()	5,697.

RL3-SFG-MTC	5,549.
--------------------	--------

Glides:
Adjustable clear nylon.

Laminate:
Rectangular tops are 1 1/8" thick with
3mm white edge band.

Base:
1 3/4" diameter steel tube, powder-coat
finish and machined aluminum
connections. Bases ship flat, with simple
assembly required.

Ross Lovegrove Round Tables

Designer(s):
Ross Lovegrove, 2007



description	w	h	weight	top
RL5M-42 Round table, medium 	42"	28"	72 lbs.	laminata
	42"	28"	129 lbs.	bronze and starphire glass
	42"	28"	129 lbs.	painted, etched glass
RL5M-48 Round table, medium 	48"	28"	85 lbs.	laminata
	48"	28"	126 lbs.	bronze and starphire glass
	48"	28"	126 lbs.	painted, etched glass
RL5L-54 Round table, large 	54"	28"	116 lbs.	laminata
	54"	28"	138 lbs.	bronze and starphire glass
	54"	28"	138 lbs.	painted, etched glass
RL5L-60 Round table, large 	60"	28"	132 lbs.	laminata
	60"	28"	163 lbs.	bronze and starphire glass
	60"	28"	163 lbs.	painted, etched glass

Order Code

<i>Example:</i>	RL5L-60-GA1-118
RL5L-60	60" Lovegrove round table
GA1	Painted Green, acid etched glass
118	White

Specify:

1. Pattern number
2. Top finish selection
3. Base finish selection

Ordering Information

Glass finishes:
 Bronze glass (suffix BRG)
 Painted green, acid etched glass (suffix GA1)
 Painted blue, acid etched glass (suffix GA2)
 Painted red, acid etched glass (suffix GA3)
 Starphire glass (suffix SFG)

Laminate finishes:
 White (suffix 118)

Base finish:
 Metallic Bronze (suffix BRM)
 Robin's Egg Blue (suffix REB)
 Silver (suffix SLV)
 White (suffix 118)

Maintenance:
 See pages 28-29.

Note:
 Top and base are shipped in separate packages. Bases have nameplate with designer's signature. **Not suitable for outdoor use.**

The Ross Lovegrove Round Table is Greenguard certified.

Construction

Glass Tops:
Starphire™ Glass Top:
 Tempered Starphire glass is more clear and luminous than regular glass. The low iron content gives glass a crystal quality. 1/8" bevel edge has an exceptionally clear character.

Bronze Glass:
 Tempered bronze colored glass; 1/2" thick with beveled edge and polished edge.

Painted Acid Etched Glass:
 Tempered acid etched top surface with painted underside.

pattern no.

RL5M-42-118-()	\$2,877.
RL5M-42-(BRG, SFG)-()	3,800.
RL5M-42-(GA1, GA2, GA3)-()	3,989.

RL5M-48-118-()	2,885.
RL5M-48-(BRG, SFG)-()	3,806.
RL5M-48-(GA1, GA2, GA3)-()	3,994.

RL5L-54-118-()	3,510.
RL5L-54-(BRG, SFG)-()	4,794.
RL5L-54-(GA1, GA2, GA3)-()	5,153.

RL5L-60-118-()	3,534.
RL5L-60-(BRG, SFG)-()	4,816.
RL5L-60-(GA1, GA2, GA3)-()	5,177.

Laminate:
Round tops are 1 1/8" thick with
3mm white edge band.

Glides:
Adjustable clear nylon.

Base:
1 3/4" diameter steel tube, powder-coat
finish and machined aluminum
connections. Bases ship flat, with simple
assembly required.

Ross Lovegrove Tri-Oval Tables

Designer(s):
Ross Lovegrove, 2007

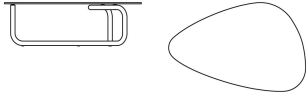
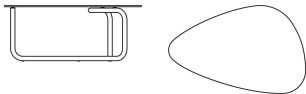

description	top w	d	h	weight	top
RL11-17 Tri-Oval Table 	54 1/2"	35"	17"	89 lbs.	bronze and starphire glass
	54 1/2"	35"	17"	89 lbs.	painted, etched glass
RL11-22 Tri-Oval Table 	54 1/2"	35"	22"	96 lbs.	bronze and starphire glass
	54 1/2"	35"	22"	96 lbs.	painted, etched glass

Order Code

<i>Example:</i>	RL11-17-BRG-BRM
RL11-17	RL11 Tri-Oval Table, 17" high
BRG	Bronze glass
BRM	Metallic Bronze

Example:

1. Pattern number
2. Top finish
3. Base finish

Ordering Information

Glass finishes:
Bronze glass (suffix BRG)
Painted green, acid etched glass (suffix GA1)
Painted blue, acid etched glass (suffix GA2)
Painted red, acid etched glass (suffix GA3)
Starphire glass (suffix SFG)

Base finish:
Metallic Bronze (suffix BRM)
Robin's Egg Blue (suffix REB)
Silver (suffix SLV)
White (suffix 118)

Maintenance:
See pages 28-29.

Note:
Top and base are shipped in separate packages. Bases have nameplate with designer's signature. **Not suitable for outdoor use.**

The Ross Lovegrove Tri-Oval Table is Greenguard certified.

Construction

Glass Tops:
Starphire™ Glass Top:
Tempered Starphire glass is more clear and luminous than regular glass. The low iron content gives glass a crystal quality. 1/8" bevel edge has an exceptionally clear character.

Bronze Glass:
Tempered bronze colored glass; 1/2" thick with beveled edge and polished edge.

Painted Acid Etched Glass:
Tempered acid etched top surface with painted underside.

pattern no.

RL11-17-(BRG,SFG)-()	\$3,742.
-----------------------------	----------

RL11-17-(GA1,GA2, GA3)-()	3,929.
----------------------------------	--------

RL11-22-(BRG,SFG)-()	3,747.
-----------------------------	--------



RL11-22-(GA1,GA2, GA3)-()	3,936.
----------------------------------	--------

Base:
1 3/4" diameter steel tube with
powder-coat finish.

Glides:
Adjustable clear nylon.

Ludwig Mies van der Rohe

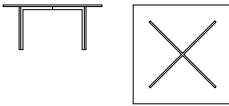
Barcelona® Table, MR Table

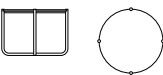
	description	w	d	h	weight	top	base
<p><i>Designer(s):</i> Ludwig Mies van der Rohe, 1930</p> 	<p>252 Barcelona table</p> 	40"	40"	17"	134 lbs.	Clear glass	Stainless steel
		40"	40"	18.5"	140 lbs.	Clear glass	Polished chrome
		40"	40"	17"	134 lbs.	Starphire glass	Stainless steel
		40"	40"	18.5"	140 lbs.	Starphire glass	Polished chrome
	<p>259TS MR table</p> 	28.5"		20.8"	37 lbs.	Clear glass	Stainless steel

Order Code

<i>Example:</i>	252C-SFG
252	Barcelona table
C	Polished Chrome
SFG	Starphire Glass

Note:
The Mies Barcelona and MR tables are part of a collection. Please refer to Mies side chairs and lounge seating beginning on page 182.

Specify:

1. Pattern number
2. Base finish option
3. Top selection

Ordering Information

Shipping:
Top and base of MR Tables ship in separate packages.

 *KnollStudio 20-Day Program:*
The Barcelona table in chrome with clear glass top and the MR table are available on the KnollStudio 20-day program. For specific information, consult pages 30-33.

Maintenance:
See pages 28-29.

Note:
The KnollStudio logo and signature of Ludwig Mies van der Rohe is stamped into the base of the MR and Barcelona tables.

The Barcelona Table and MR Table are Greenguard certified.

Construction

BARCELONA TABLE
Clear Glass Top:
3/4" thick top with a 1/8" wide beveled edge. Top and edges have a slight green tint.

Starphire™ Glass Top:
Starphire glass is more clear and luminous than regular glass. The low iron content gives glass a crystal quality. 1/8" bevel edge has an exceptionally clear character.

Stainless Steel Base:
Premium grade 202 bar stock stainless steel. Single piece construction ensures long-term durability. Frame hand-ground and hand-buffed to mirror finish.

Polished Chrome Base:
Hand-ground and hand-buffed to a mirror finish. Single piece construction.

Bumpers:
Polished Chrome table has black bumpers. Stainless steel table has white bumpers.

MR TABLE
Top:
1/2" thick clear polished plate glass.

Base:
Frame and legs are tubular and rectangular stainless steel welded together. Seamless construction buffed to a mirror finish.



pattern no.

252	\$4,327.
252C 	2,606.
252-SFG	4,835.
252C-SFG	3,258.

259TS-G 	2,056.
--	--------

Ludwig Mies van der Rohe

Krefeld™ Side and Coffee Table

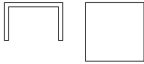
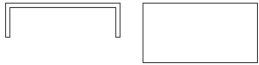
	description	w	d	h	weight
<p><i>Designer(s):</i> Ludwig Mies van der Rohe, 1930 Design from the Mies van der Rohe Archive of The Museum of Modern Art</p>  	<p>759 Square Table</p> 	27 1/2"	27 1/2"	17 3/4"	35 lbs.
	<p>760 Rectangular Coffee Table</p> 	54"	27 1/2"	17 3/4"	63 lbs.

Order Code

<i>Example:</i>	759-OWE
759	Krefeld square coffee table
OWE	Wenge

Note:
The Mies Krefeld tables are part of a collection. Please refer to Mies side chairs and lounge seating beginning on page 182.

Specify:

1. Pattern number
2. Finish selection

Ordering Information

Table finishes:
Wenge (OWE)
Medium Cherry (OM)
Deep Red Mahogany (OF)
Light Walnut (OWA)
Clear Oak (OC)

Maintenance:
See pages 27-28.

Construction





Base and Top:
Oak with stained or clear oak finish.
Open pore finish. Black plastic glides.
Seamless connection between top and base.

pattern number	clear oak	stained finishes
759-()	\$2,403.	\$2,474.
760-()	5,142.	5,294.

Pascal Mourgue

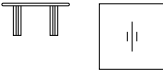
Square and Rectangular Conference Tables

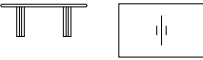
PVC-T edge

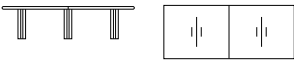
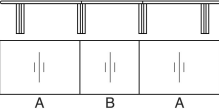
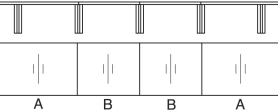
	description	seating capacity *	section	legs	w	d	h	weight	top
Designer(s): Pascal Mourgue, 1985 Award(s): The Roscoe Commendation, USA 1985; IBD Product Design Award, 1985; Corporate Design and Reality Product Design Award, 1986	47TS15 square table 	8	1	4	60 1/4"	60 1/4"	28 3/4"	309 lbs.	Coated marble
		8	1	4	60 1/4"	60 1/4"	28 3/4"	309 lbs.	Natural marble
		8	1	4	60 1/4"	60 1/4"	28 3/4"	178 lbs.	Laminate
		8	1	4	60 1/4"	60 1/4"	28 3/4"	166 lbs.	Veneer
	47TS20 rectangular table 	8	1	4	80"	48 1/2"	28 3/4"	328 lbs.	Coated marble
		8	1	4	80"	48 1/2"	28 3/4"	328 lbs.	Natural marble
		8	1	4	80"	48 1/2"	28 3/4"	187 lbs.	Laminate
		8	1	4	80"	48 1/2"	28 3/4"	175 lbs.	Veneer
	47TS31 rectangular table 	10	2	6	120"	48 1/2"	28 3/4"	279 lbs.	Laminate
		10	2	6	120"	48 1/2"	28 3/4"	262 lbs.	Veneer
	47TS48 rectangular table	16	3	8	204"	48 1/2"	28 3/4"	450 lbs.	Laminate
		16	3	8	204"	48 1/2"	28 3/4"	425 lbs.	Veneer
	47TS64 rectangular table	22	4	10	268"	48 1/2"	28 3/4"	586 lbs.	Laminate
		22	4	10	268"	48 1/2"	28 3/4"	554 lbs.	Veneer

* Based on 26" wide arm chairs

Order Code

<i>Example:</i>	47TS31-1-V315
47TS31	Pascal rectangular table
1	Black Epoxy
V315	Light Cherry Veneer
<i>Example:</i>	47TSV15-AP-119-V315
47TSV15	Pascal square table, with veneer edge
AP	Polished Aluminum
119	Pumice
V315	Light Cherry Veneer

Specify:

1. Pattern number
2. Leg finish selection
3. Top finish selection
4. Wood bullnose finish selection (for laminate tops only)

Ordering Information

Leg finishes:
Matte Black Epoxy (suffix 1)
Polished Aluminum (suffix AP)

Laminate finishes:
Bright White (suffix 118)
Folkstone Grey (suffix 114)
Fog (suffix 128)
Jet Black (suffix 111)
Light Grey (suffix L)
Pumice (suffix 119)
Slate (suffix SL)
Soft Grey (suffix 117)

Veneer/bullnose finishes:
American Cherry (suffix X)
Ebonized Walnut (suffix D)
Light Cherry (suffix V315)
Maple (suffix K)
Medium Red Mahogany (suffix Z)
Natural Beech (suffix B)
Warm Brown Walnut (suffix J)

Polished Coated marble finishes:
Carrara: white-grey (suffix GC)
Emperador Dark: dark brown (suffix GE)
Empire Beige: beige (suffix GB)

Natural marble finishes:
Carrara: white-grey (suffix NGC)
Emperador Dark: dark brown (suffix NGE)

Veneer edge:
For veneer edge, add 'V' after 4th digit.
For example, for a 48 1/2" square table with veneer edge, specify 47TSV12.

Certified Wood:

Tables manufactured using FSC certified hardwoods and veneers and/or LEED compliant recyclable components are available through Custom Product Development. Extended leadtime and upcharge apply.

Maintenance:

See pages 28-29.

Note:

Polyester marble coating will yellow over time.

The Pascal Table with Laminate top and PVC edge is Greenguard certified.

pattern no.	pvc edge	veneer edge (add V after 4th digit)	marble top
47TS15-(1, AP)-(GC, GE, GB)			\$12,904.
47TS15-(1, AP)-(NGC, NGE)			10,835.
47TS15-(1, AP)-(-)(-)	4,423.	5,159.	
47TS15-(1, AP)-(-)	4,973.	6,077.	
47TS20-(1, AP)-(GC, GE, GB)			13,040.
47TS20-(1, AP)-(NGC, NGE)			10,971.
47TS20-(1, AP)-(-)(-)	4,423.	4,973.	
47TS20-(1, AP)-(-)	5,159.	6,077.	
47TS31-(1, AP)-(-)(-)	6,814.	8,475.	
47TS31-(1, AP)-(-)	8,290.	10,130.	
47TS48-(1, AP)-(-)(-)	12,101.	14,366.	
47TS48-(1, AP)-(-)	15,840.	17,869.	
47TS64-(1, AP)-(-)(-)	13,918.	17,516.	
47TS64-(1, AP)-(-)	19,709.	22,104.	

Construction

Combining tables:

If individual tables are purchased with the intent of placing them contiguously, they should be quoted for flitch or book match. When desired specifically for combination, note that information on the order so that bullnose edges and legs at each table junction are removable. Leveling strip slides into slots at edges. Legs connect into inserts that span tops. Bullnose edges store for future retrieval and separation.

Standard size tables:

For additional standard size tables please consult your KnollStudio representative, dealer or Customer Service associate.

Special width tables:

For standard depth tables (42 $\frac{3}{4}$ ", 48 $\frac{1}{2}$ ", and 60 $\frac{1}{4}$ "), you may determine list pricing on any special width between two standard sizes simply by identifying the next higher standard width tables, and add 5% to the standard list price.

For example, if requesting an 80" w x 42 $\frac{3}{4}$ " d table, you would identify the next wider table (84" w x 42 $\frac{3}{4}$ " d) and add 5% to the list price of that standard size. Consult a KnollStudio representative for special Order Code.

Special sizes and finishes:

For all other sizes and for special finishes, consult your KnollStudio representative, dealer, or Customer Services for information.

Legs:

Extruded aluminum leg in black epoxy or polished aluminum finish. Multiple sectioned tables have two legs bridging each section, plus two legs at each end.

Marble top:

13/16" thick marble coated with transparent polyester to help eliminate use-associated stains.

Laminate and wood tops:

Tops are 1 $\frac{1}{8}$ " thick. Wood tops are cross-veneered. Tops available with black semi-gloss extruded PVC-T mold bullnose edge or stained solid wood bullnose edge. For PVC-T bullnose, short ends of rectangular table have a wood bullnose with a black semi-gloss paint to match the PVC-T edges.

Glides:

Adjustable nylon, black epoxy finish.

Shipping:

Top and base shipped in separate pieces; assembly required.

To assemble:

Legs connect into predrilled inserts using mounting hardware (included).

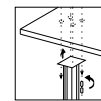



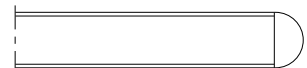



Bullnose edge detail:

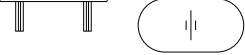

Pascal Mourgue

Round and Racetrack Conference Tables

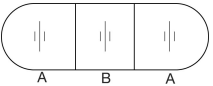
PVC-T edge

	description	seating capacity *	section	legs	w	d	h	weight	top
Designer(s): Pascal Mourgue, 1985 Award(s): The Roscoe Commendation, USA 1985; IBD Product Design Award, 1985; Corporate Design and Reality Product Design Award, 1986	47TR15 round table 	7	1	4	60 1/4"		28 3/4"	250 lbs.	Coated marble
		7	1	4	60 1/4"		28 3/4"	250 lbs.	Natural marble
		7	1	4	60 1/4"		28 3/4"	147 lbs.	Laminate
		7	1	4	60 1/4"		28 3/4"	138 lbs.	Veneer
	47TR24 racetrack table 	8	1	4	97"	48 1/2"	28 3/4"	605 lbs.	Coated marble
		8	1	4	97"	48 1/2"	28 3/4"	605 lbs.	Natural marble
		8	1	4	97"	48 1/2"	28 3/4"	315 lbs.	Laminate
		8	1	4	97"	48 1/2"	28 3/4"	313 lbs.	Veneer
	47TR26 racetrack table 	8	2	6	108"	48 1/2"	28 3/4"	380 lbs.	Laminate
8		2	6	108"	48 1/2"	28 3/4"	377 lbs.	Veneer	
	47TR30 racetrack table 	10	2	6	120"	48 1/2"	28 3/4"	280 lbs.	Laminate
10		2	6	120"	48 1/2"	28 3/4"	262 lbs.	Veneer	
	47TR50 racetrack table 	16	3	8	192"	60 1/4"	28 3/4"	510 lbs.	Laminate
16		3	8	192"	60 1/4"	28 3/4"	485 lbs.	Veneer	
	47TR72 racetrack table 	6	1	4	84"	42 3/4"	28 3/4"	177 lbs.	Laminate
6		1	4	84"	42 3/4"	28 3/4"	165 lbs.	Veneer	

* Based on 26" wide arm chairs

Order Code

<i>Example:</i>	47TR26-1-K
47TR26	Pascal racetrack table
1	Black Epoxy
K	Maple Veneer
<i>Example:</i>	47TRV15-AP-J
47TRV15	Pascal round table, with veneer edge
AP	Polished Aluminum
J	Warm Brown Walnut Veneer

Ordering Information

Specify:

1. Pattern number
2. Leg finish selection
3. Top finish selection
4. Wood bullnose finish selection (for laminate tops only)

Leg finishes:

Matte Black Epoxy (suffix I)
 Polished Aluminum (suffix AP)

Laminate finishes:

Bright White (suffix 118)
 Fog (suffix 128)
 Folkstone Grey (suffix 114)
 Jet Black (suffix 111)
 Light Grey (suffix L)
 Pumice (suffix 119)
 Soft Grey (suffix 117)
 Slate (suffix SL)

Veneer/bullnose finishes:

American Cherry (suffix X)
 Ebonized Walnut (suffix D)
 Light Cherry (suffix V315)
 Maple (suffix K)
 Medium Red Mahogany (suffix Z)
 Natural Beech (suffix B)
 Warm Brown Walnut (suffix J)

Polished Coated marble finishes:

Carrara: white-grey (suffix GC)
 Emperador Dark: dark brown (suffix GE)
 Empire Beige: beige (suffix GB)

Natural marble finishes:

Carrara: white-grey (suffix NGC)
 Emperador Dark: dark brown (suffix NGE)

Veneer edge:

For veneer edge, add 'V' after 4th digit.
 For example, for a 48 1/2" round table, specify 47TRV12.

Certified Wood:

Tables manufactured using FSC certified hardwoods and veneers and/or LEED compliant recyclable components are available through Custom Product Development. Extended leadtime and upcharge apply.

Maintenance:

See pages 28-29.

Note:

Polyester marble coating will yellow over time.

The Pascal Table with Laminate top and PVC edge is Greenguard certified.

pattern no.	pvc edge	veneer edge (add V after 4th digit)	marble top
47TR15-(1, AP)-(GC, GE, GB)			\$10,360.
47TR15-(1, AP)-(NGC, NGE)			8,787.
47TR15-(1, AP)-(-)(-)	4,606.	6,077.	
47TR15-(1, AP)-(-)	5,159.	7,183.	
47TR24-(1, AP)-(GC, GE, GB)			15,448.
47TR24-(1, AP)-(NGC, NGE)			12,887.
47TR24-(1, AP)-(-)(-)	5,343.	7,183.	
47TR24-(1, AP)-(-)	6,261.	8,475.	
47TR26-(1, AP)-(-)(-)	6,453.	8,674.	
47TR26-(1, AP)-(-)	7,664.	10,087.	
47TR30-(1, AP)-(-)(-)	7,664.	10,488.	
47TR30-(1, AP)-(-)	10,087.	12,507.	
47TR50-(1, AP)-(-)(-)	11,788.	16,764.	
47TR50-(1, AP)-(-)	19,163.	23,802.	
47TR72-(1, AP)-(-)(-)	4,790.	6,261.	
47TR72-(1, AP)-(-)	5,526.	7,736.	

Construction

Standard size tables:

For additional standard size tables please consult your KnollStudio representative, dealer or Customer Service associate.

Special width tables:

For standard depth tables (42³/₄" , 48¹/₂" , and 60¹/₄"), you may determine list pricing on any special width between two standard sizes simply by identifying the next higher standard width tables, and add 5% to the standard list price.

For example, if requesting an 80" w x 42³/₄" d table, you would identify the next wider table (84" w x 42³/₄" d) and add 5% to the list price of that standard size. Consult a KnollStudio representative for special Order Code.

Special sizes and finishes:

For all other sizes and for special finishes, consult your KnollStudio representative, dealer, or Customer Services for information.

Legs:

Extruded aluminum leg in black epoxy or polished aluminum finish. Multiple sectioned tables have two legs bridging each section, plus two legs at each end.

Laminate and wood tops:

Tops are 1¹/₈" thick. Wood tops are cross-veneered. Tops available with black semi-gloss extruded PVC-T mold bullnose edge or stained solid wood bullnose edge. Bullnose edges on ends of racetrack tables are single, continuous arcs of wood.

Marble top:

13/16" thick marble coated with transparent polyester to help eliminate use-associated stains.

Glides:

Adjustable nylon, black epoxy finish.

Shipping:

Top and base shipped in separate pieces; assembly required.

To assemble:

Legs connect into predrilled inserts using mounting hardware (included).

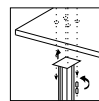

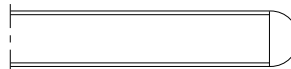

Bullnose edge detail:



Pascal Mourgue

Bullet Conference Tables

PVC-T edge

	description	seating capacity *	section	legs	w	d	h	weight	top
Designer(s): Pascal Mourgue, 1985 Award(s): The Roscoe Commendation, USA 1985; IBD Product Design Award, 1985; Corporate Design and Reality Product Design Award, 1986	47TR22 bullet table 	8	1	4	87 3/4"	48 1/2"	28 3/4"	356 lbs.	Coated marble
		8	1	4	87 3/4"	48 1/2"	28 3/4"	356 lbs.	Natural marble
		8	1	4	87 3/4"	48 1/2"	28 3/4"	201 lbs.	Laminate
		8	1	4	87 3/4"	48 1/2"	28 3/4"	188 lbs.	Veneer
	47TR19 bullet table 	7	1	4	76"	60 1/4"	28 3/4"	353 lbs.	Coated marble
		7	1	4	76"	60 1/4"	28 3/4"	353 lbs.	Natural marble
		7	1	4	76"	60 1/4"	28 3/4"	200 lbs.	Laminate
		7	1	4	76"	60 1/4"	28 3/4"	187 lbs.	Veneer

* Based on 26" wide arm chairs

Order Code

<i>Example:</i>	47TR19-AP-111
47TR19	Pascal bullet table
AP	Polished Aluminum
111	Jet Black Laminate
<i>Example:</i>	47TRV22-1-111-B
47TRV22	Pascal bullet table, with veneer edge
1	Black Epoxy
111	Jet Black Laminate
B	Natural Beech Veneer

Ordering Information

Specify:

1. Pattern number
2. Leg finish selection
3. Top finish selection
4. Wood bullnose finish selection (for laminate tops only)

Leg finishes:
 Matte Black Epoxy (suffix I)
 Polished Aluminum (suffix AP)

Laminate finishes:
 Bright White (suffix 118)
 Fog (suffix 128)
 Jet Black (suffix 111)
 Light Grey (suffix L)
 Pumice (suffix 119)
 Slate (suffix SL)

Laminate finishes, continued:
 Folkstone Grey (suffix 114)
 Soft Grey (suffix 117)

Veneer/bullnose finishes:
 American Cherry (suffix X)
 Ebonized Walnut (suffix D)
 Light Cherry (suffix V315)
 Maple (suffix K)
 Medium Red Mahogany (suffix Z)
 Natural Beech (suffix B)
 Warm Brown Walnut (suffix J)

Polished Coated marble finishes:
 Carrara: white-grey (suffix GC)
 Emperador Dark: dark brown (suffix GE)
 Empire Beige: beige (suffix GB)

Natural marble finishes:
 Carrara: white-grey (suffix NGC)
 Emperador Dark: dark brown (suffix NGE)

Veneer edge:
 For veneer edge, add 'V' after 4th digit.
 For example, for a 204" x 60 1/4" rectangular table with veneer edge, specify 47TSV52.

pattern no.	pvc edge	veneer edge (add V after 4th digit)	marble top
47TR22-(1, AP)-(GC, GE, GB)			\$13,506.
47TR22-(1, AP)-(NGC, NGE)			11,340.
47TR22-(1, AP)-(-)(-)	5,044.	6,814.	
47TR22-(1, AP)-(-)	5,526.	7,736.	
47TR19-(1, AP)-(GC, GE, GB)			14,326.
47TR19-(1, AP)-(NGC, NGE)			11,994.
47TR19-(1, AP)-(-)(-)	5,044.	6,814.	
47TR19-(1, AP)-(-)	5,526.	7,736.	

Construction

Certified Wood:

Tables manufactured using FSC certified hardwoods and veneers and/or LEED compliant recyclable components are available through Custom Product Development. Extended leadtime and upcharge apply.

Maintenance:

See pages 28-29.

Note:

Polyester marble coating will yellow over time.

The Pascal Table with Laminate top and PVC edge is Greenguard certified.

Standard size tables:

For additional standard size tables please consult your KnollStudio representative, dealer or Customer Service associate.

Special width tables:

For standard depth tables (42³/₄" , 48¹/₂" , and 60¹/₄"), you may determine list pricing on any special width between two standard sizes simply by identifying the next higher standard width tables, and add 5% to the standard list price.

For example, if requesting an 80" w x 42³/₄" d table, you would identify the next wider table (84" w x 42³/₄" d) and add 5% to the list price of that standard size. Consult a KnollStudio representative for special Order Code.

Special sizes and finishes:

For all other sizes and for special finishes, consult your KnollStudio representative, dealer, or Customer Services for information.

Legs:

Extruded aluminum leg in black epoxy or polished aluminum finish. Multiple sectioned tables have two legs bridging each section, plus two legs at each end.

Laminate and wood tops:

Tops are 1¹/₈" thick. Wood tops are cross-veneered. Tops available with black semi-gloss extruded PVC-T mold bullnose edge or stained solid wood bullnose edge. Bullnose edges on ends of racetrack tables are single, continuous arcs of wood.

Marble top:

1¹/₁₆" thick marble coated with transparent polyester to help eliminate use-associated stains.

Glides:

Adjustable nylon, black epoxy finish.

Shipping:



Top and base shipped in separate pieces; assembly required.

To assemble:

Legs connect into predrilled inserts using mounting hardware (included).

George Nakashima

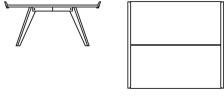
Splay-Leg Table and Tray

	description	w	d	h	weight
<p><i>Designer(s):</i> George Nakashima, 1946</p> 	<p>N10 Splay-Leg Table</p> 	37 7/8"	34 1/4"	17 1/2"	33 lbs.
	<p>N20 Tray</p> 	21 3/8"	16"	1 3/4"	5 lbs.

Order Code

<i>Specify:</i>	N10-HK-AW
N10	Splay-Leg Table
HK	Hickory
AW	American Walnut
<i>Specify:</i>	N20-DF-BS
N20	Tray
DF	Douglas Fir
BS	Brazilian Santos

Note:

The Splay-Leg Table and Tray are part of a collection. Please refer to the Straight chair on page 200.

For Splay-Leg Table, specify:

1. Pattern number
2. Primary finish
3. Edge detail finish

For Splay-Leg Tray, specify:

1. Pattern number
2. Tray finish
3. Edge detail finish

Ordering Information

Finishes, table only:
American Walnut (suffix AW)
Hickory (suffix HK)

Finishes, tray only:
Brazilian Santos (suffix BS)
Douglas Fir (suffix DF)
Wenge (suffix WG)

Maintenance:
See pages 28-28.

Note:
Each table and tray features George Nakashima's signature under the table top.

The Splay-Leg Table is Greenguard certified.

Construction

TABLE:
Top:
Tops are veneered with reverse slip-matched cathedral pattern, matching solid wood edge in clear low-sheen finish.

Legs, apron and edge detail:
Solid American Walnut. Mortise and tenon joints with solid brass hardware. Nylon glides. Edge detail finish is available in American Walnut only.

TRAY:
Top:
Tops are constructed of solid Douglas Fir lumber that is quarter-cut and finished in a clear low-sheen finish.

Edge detail:
Available in two finishes: solid Brazilian Santos; solid Wenge. Edge details are joined to top with mortise and tenon joints.

pattern no.

N10-()-AW

\$2,719.

N20-DF-()



591.

Isamu Noguchi

Cyclone™ Dining and Side Tables

Designer(s):
Isamu Noguchi, 1954

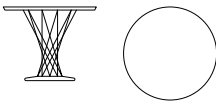

description	w	d	h	weight	top	base
311 Cyclone Dining table 	36"		28"	89 lbs.	Black laminate	Cast iron black
	36"		28"	89 lbs.	White laminate	Cast iron black
312 Cyclone Dining table 	42"		28"	97 lbs.	Black laminate	Cast iron black
	42"		28"	97 lbs.	White laminate	Cast iron black
87 Side table 	24"		20"	31 lbs.	Black laminate	Cast iron black
	24"		20"	31 lbs.	White laminate	Cast iron black



Order Code

<i>Example:</i>	312-F2
312	Cyclone dining table
F2	White Laminate top

Specify:

1. Pattern number
2. Top finish selection

Ordering Information

Laminate top finish:
 Black (F1)
 White (F2)

 **KnollStudio 20-Day Program:**
 The Noguchi table is available on the KnollStudio 20-day program in round 36" with a white laminate top. For more specific information, please consult pages 30-33.

Note:
 Each table features a signature plate under the table top with the KnollStudio logo and Isamu Noguchi's signature.

Maintenance:
 See pages 28-29.

Note:
 The Cyclone Table is Greenguard certified.

pattern no.

311-F1	\$3,080.
---------------	----------

311-F2 	3,080.
---	--------

312-F1	3,383.
---------------	--------

312-F2	3,383.
---------------	--------

87-F1	2,031.
--------------	--------

87-F2	2,031.
--------------	--------

Construction

Noguchi table top:

Top is black or white laminate with a natural birch edge. Top is 0.8" thick.





Noguchi table base:

Cast iron, black textured powder-coat.

Noguchi table column:

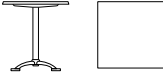
Steel wire column, chrome plated finish.

Jorge Pensi
Pensi Tables
Small Cafe Tables

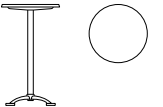
	description	top	w	d	h	weight
<i>Designer(s):</i> Jorge Pensi, 1988	29TS-27 Square café table 	Disks, wrapped edge	27 1/2"	27 1/2"	28 1/4"	35 lbs.
		Metallic Trespa, natural black edge	27 1/2"	27 1/2"	28 1/4"	32 lbs.
<i>Award(s):</i> First Place, Sidi Selection, Valencia, Spain, 1988; "Delta Plate" of ADI FAD, 1988; Design Center Stuttgart Award, W. Germany, 1990	29TR-27 Round café table 	Disks, wrapped edge	27 1/2"		28 1/4"	31 lbs.
		Metallic Trespa, natural black edge	27 1/2"		28 1/4"	27 lbs.
	29TR-23 Round café table 	Disks, wrapped edgeband	23 7/8"		28 1/4"	25 lbs.
		Metallic Trespa, natural black edge	23 7/8"		28 1/4"	23 lbs.
	29TR-H-23 Bar-height café table 	Disks, wrapped edge	23 7/8"		43 1/3"	26 lbs.
		Metallic Trespa, natural black edge	23 7/8"		43 1/3"	24 lbs.

Order Code

<i>Example:</i>	29TS-27-DE
29TS	Pensi table, square top
27	27" wide and deep
DE	Disks, wrapped edge

Note:
Pensi Tables are part of a collection. Please refer to Toledo chairs on page 204.

Specify:

1. Pattern number
2. Table size
3. Top finish selection

Ordering Information

Table top finishes:
 Disks, wrapped edge (suffix DE)
Metallic laminate (suffix LM)

Note:
The Pensi Tables are available in the United States only.

 *KnollStudio 20-Day Program:*
Pensi tables are available on the KnollStudio 20-day program in a round 23" bar height size with concentric circle finish and in the round 27" size with disks finish. For specific information, please consult pages 30-33.

Maintenance:
See pages 28-29.

Note:
The Pensi Table is Greenguard certified.

Construction

Top:
Two stainless steel finishes: acid-etched pattern of concentric circles; sanded pattern of scalloped, compact disk-like, 1 1/4" wide circles; both with wrapped edge. One metallic Trespa option with a natural black phenolic edge. The Trespa metallic (LM) top finish is UV resistant, does not reflect heat, easy to clean and made of recyclable materials. The Trespa metallic (LM) top finish is ideal for outdoor use.

pattern no.

29TS-27-DE	\$1,595.
29TS-27-LM	2,629.

29TR-27-DE 	1,595.
29TR-27-LM	2,629.

29TR-23-DE	1,449.
29TR-23-LM	2,020.

29TR-H-23-DE	1,780.
29TR-H23-LM	2,402.

Base:
Anodized and polished cast aluminum with 4 7/8" pad-like feet. Four-star base on cafe tables. Five-star base on bistro and dining tables. The central column is a polished and anodized aluminum round tube. Internal weight for additional stability. Black silicone non-scuffing glides.

Outdoor use:
With proper preventative maintenance, the Toledo Table is appropriate for outdoor environments.

Square tables, Disks, wrapped edge (DE)

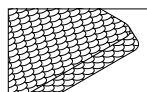

Round tables, Disks, wrapped edge (DE)

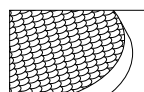





Round tables, metallic laminate top, phenolic black edge (LM)

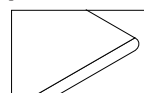

Square tables, Metallic laminate top, phenolic black edge (LM)

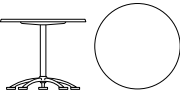
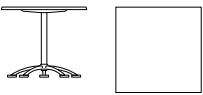

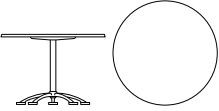
Jorge Pensi
Pensi Tables
Large Bistro Tables

	description	top	w	d	h	weight
<i>Designer(s):</i> Jorge Pensi, 1988	29TR-35 Round bistro table 	Disks, wrapped edge	35 3/8"		29 1/2"	50 lbs.
		Metallic Trespa, natural black edge	35 3/8"		29 1/2"	46 lbs.
<i>Award(s):</i> First Place, Sidi Selection, Valencia, Spain, 1988; "Delta Plate" of ADI FAD, 1988; Design Center Stuttgart Award, W. Germany, 1990	29TS-35 Square bistro table 	Disks, wrapped edge	35 3/8"	35 3/8"	29 1/2"	58 lbs.
		Metallic Trespa, natural black edge	35 3/8"	35 3/8"	29 1/2"	54 lbs.
	29TR-43 Round dining table 	Disks, wrapped edge	43 1/4"		29 1/2"	65 lbs.
		Metallic Trespa, natural black edge	43 1/4"		29 1/2"	57 lbs.
						

Order Code



<i>Example:</i>	29TS-35-DE
29TS	Pensi table
35	35" wide and deep
DE	Disks, wrapped edge

Note:
Pensi Tables are part of a collection. Please refer to Toledo chairs on page 204.

Specify:

1. Pattern number
2. Table size
3. Top finish selection

Ordering Information

Table top finishes:
 Disks, wrapped edge (suffix DE)
 Metallic laminate (suffix LM)

Note:
The Pensi Tables are available in the United States only.

 *KnollStudio 20-Day Program:*
The Pensi bistro table is available on the KnollStudio 20-Day program in square 35" size with disks finish and 39" size with disks finish. For specific information, please consult pages 30-33.

Maintenance:
See pages 28-29.

Note:
The Pensi Table is Greenguard certified.

Construction

Top:
Two stainless steel finishes: acid-etched pattern of concentric circles; sanded pattern of scalloped, compact disk-like, 1 1/4" wide circles; both with wrapped edge. One metallic Trespa option with a natural black phenolic edge. The Trespa metallic (LM) top finish is UV resistant, does not reflect heat, easy to clean and made of recyclable materials. The Trespa metallic (LM) top finish is ideal for outdoor use.

pattern no.

29TR-35-DE	\$3,712.
29TR-35-LM	4,430.

29TS-35-DE 	3,712.
29TS-35-LM	4,430.

29TR-43-DE	4,538.
29TR-43-LM	7,718.

Base:
Anodized and polished cast aluminum with 4 7/8" pad-like feet. Four-star base on cafe tables. Five-star base on bistro and dining tables. The central column is a polished and anodized aluminum round tube. Internal weight for additional stability. Black silicone non-scuffing glides.

Outdoor use:
With proper preventative maintenance, the Toledo Table is appropriate for outdoor environments.

Square tables, Disks, wrapped edge (DE)

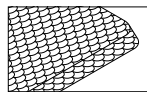

Round tables, Disks, wrapped edge (DE)

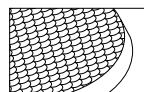

Round tables, metallic laminate top, phenolic black edge (LM)



Square tables, Metallic laminate top, phenolic black edge (LM)

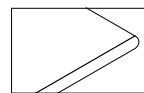

Piiroinen

Arena Cafe Tables

Designer(s):
Piiroinen, 2003

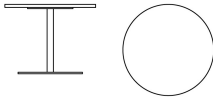
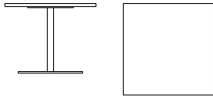
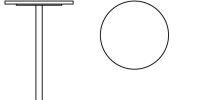
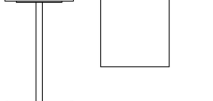

description	w	d	h	weight
23TR Round Cafe Table 	24"	24"	28 1/4"	44 lbs.
	27"	27"	28 1/4"	47 lbs.
	36"	36"	28 1/4"	73 lbs.
	42"	42"	28 1/4"	81 lbs.
23TS Square Cafe Table 	24"	24"	28 1/4"	63 lbs.
	30"	30"	28 1/4"	70 lbs.
23TRH Bar-height Round Cafe Table 	24"	24"	41 1/2"	46 lbs.
	27"	27"	41 1/2"	49 lbs.
23TSH Bar-height Square Cafe Table 	24"	24"	41 1/2"	65 lbs.
	27"	27"	41 1/2"	69 lbs.



Order Code

<i>Example:</i>	23TR24-C-W
23TR24	Arena cafe table, 24"
C	Chrome
W	White

Specify:

1. Pattern number
2. Column finish selection
3. Top finish

Ordering Information

Column Finish:
 Chrome (C)
 Silver grey paint (S)

Top finish:
 White (W)

 **KnollStudio 20-Day Program:**
 The Arena table is available on the 20-day program in round 36" dining height with chrome base and white finish. Please consult pages 30-33.

Note:
 The Arena Cafe Table is Greenguard certified.

Construction

Top:
 Top is laminate with a natural birch edge. Top is .8" thick. Top is connected to base via mounting plate.

pattern no.	silver grey base	chrome base
23TR24-()-()	\$2,199.	\$2,285.
23TR27-()-()	2,392.	2,471.
23TR36-()-() 	2,839.	2,920.
23TR42-()-()	3,102.	3,185.
<hr/>		
23TS24-()-()	2,199.	2,285.
23TS30-()-()	2,321.	2,398.
<hr/>		
23TRH24-()-()	2,199.	2,285.
23TRH27-()-()	2,392.	2,471.
<hr/>		
23TSH24-()-()	2,199.	2,285.
23TSH27-()-()	2,392.	2,471.

Base:



Base and mounting plates are solid steel. Laser cut and always finished in a silver grey powder coat finish. The column is bolted to both the base plate and mounting plate. The 24" and 27" round tables comprise a 19.7" round base plate. All other size tables, round and square comprise a 25.5" round baseplate. Column is 2.36" in diameter.

Warren Platner

Dining and Side Tables

Designer(s):
Warren Platner, 1962

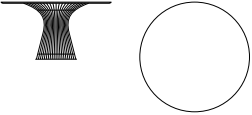

description	base w	w	h	weight	top
3716T Dining table 	20 3/4"	53 3/4"	27"	152 lbs.	Clear glass
	20 3/4"	53 3/4"	27"	152 lbs.	Bronze glass
	20 3/4"	53 3/4"	27"	254 lbs.	Natural marble
	20 3/4"	53 3/4"	27"	254 lbs.	Coated marble
	20 3/4"	53 3/4"	27"	254 lbs.	Coated marble
	20 3/4"	53 3/4"	27"	254 lbs.	Coated marble
	20 3/4"	53 3/4"	27"	267 lbs.	Granite
	20 3/4"	53 3/4"	27"	227 lbs.	Veneer
	20 3/4"	53 3/4"	27"	227 lbs.	Pearwood
	20 3/4"	53 3/4"	27"	254 lbs.	Coated marble
3710T Side table 	13"	15 3/4"	18"	14 lbs.	Clear glass
	13"	15 3/4"	18"	14 lbs.	Bronze glass
	13"	15 3/4"	18"	22 lbs.	Natural marble
	13"	15 3/4"	18"	22 lbs.	Coated marble
	13"	15 3/4"	18"	22 lbs.	Coated marble
	13"	15 3/4"	18"	22 lbs.	Coated marble
	13"	15 3/4"	18"	22 lbs.	Coated marble
	13"	15 3/4"	18"	15 lbs.	Veneer
	13"	15 3/4"	18"	15 lbs.	Pearwood
	13"	15 3/4"	18"	25 lbs.	Granite
	13"	15 3/4"	18"	22 lbs.	Natural marble

Order Code

<i>Example:</i>	3710T-N-BRG
3710T	Platner side table
N	Nickel
BRG	Bronze Glass



Note:
Platner dining and side tables are part of a collection. Please refer to Platner lounge seating on page 214 and Platner coffee tables on page 368.

Specify:



1. Pattern number
2. Base finish option
3. Top option

Ordering Information

Frame:

-  Polished Nickel (suffix N)
-  Metallic Bronze (suffix BRM)
- 18k Gold Plated (suffix GLD)

Glass top finishes:

-  Clear Glass (suffix G2)
-  Bronze Glass (suffix BRG)

Veneer finishes:

- Ebonized Walnut (suffix D)
- Light Oak (suffix LO)
- Light Walnut (suffix LWA)
- Reff Dark Cherry (suffix V314)

Pearwood finish:

- Pearwood (suffix P)

Polished Coated marble top finishes:

- Arabescato: white-grey (suffix MA)
- Carrara: white-grey (suffix GC)
- Calacatta: white-grey/beige (suffix MC)
- Emperador Dark: dark brown (suffix GE)
- Empire Beige: beige (suffix GB)
- Grey Marble: light grey (suffix GG)
- Nero Marquina: black (suffix MN)
- Verde Alpi: green (suffix MV)

Satin Coated marble top finishes:



- Arabescato: white-grey (suffix MAS)
- Calacatta: white-grey/beige (suffix MCS)
- Carrara: white-grey (suffix GCS)
- Emperador Dark: dark brown (suffix GES)
- Empire Beige: beige (suffix GBS)
- Grey Marble: light grey (suffix GGS)
- Nero Marquina: black (suffix MNS)
- Verde Alpi: green (suffix MVS)

Natural marble top finishes:

- Calacatta: white-grey/beige (suffix NC)
- Carrara: white-grey (suffix NGC)
- Emperador Dark: dark brown (suffix NGE)

Granite top finish:

- Black Andes: black (suffix GA)

pattern no.	polished nickel	metallic bronze	gold plated
3716T-()-G2	\$5,411.	\$5,735.	\$8,405.
3716T-()-BRG	5,681.	6,021.	8,826.
3716T-()-(NGC, NGE)	7,940.	9,196.	12,334.
3716T-()-(GC, GCS, GB, GBS, GE, GES)	8,902.	10,160.	13,829.
3716T-()-(MN, MNS, MA, MAS, GG, GGS)	9,622.	10,199.	14,947.
3716T-()-(MC, MCS)	10,022.	10,625.	15,568.
3716T-()-(GA)	10,715.	11,974.	16,645.
3716T-()-(LO, LWA, D, V314)	11,439.	12,125.	17,770.
3716T-()-(P)	12,381.	13,122.	19,232.
3716T-()-(MV, MVS)	12,905.	13,677.	20,046.
3716T-()-(NC)	13,926.	14,762.	21,632.
3710T-()-G2 	1,259.	1,683.	2,200.
3710T-()-BRG 	1,320.	1,767.	2,308.
3710T-()-(NGC, NGE)	1,708.	2,160.	2,653.
3710T-()-(GC, GCS, GB, GBS, GE, GES)	1,844.	2,297.	2,864.
3710T-()-(MN, MNS, MA, MAS, GG, GGS)	2,065.	2,190.	3,208.
3710T-()-(MV, MVS)	2,092.	2,218.	3,250.
3710T-()-(MC, MCS)	2,168.	2,300.	3,368.
3710T-()-(LO, LWA, D, V314)	2,874.	3,045.	4,464.
3710T-()-(P)	3,089.	3,273.	4,798.
3710T-()-(GA)	3,499.	3,952.	5,435.
3710T-()-(NC)	3,914.	4,365.	6,080.

Construction

Maintenance:

See pages 28-29.

KnollStudio 20-Day Program:

The Platner side table 3710 in selected finishes are available on the KnollStudio 20-Day program. For specific information, consult pages 30-33.

Note:

Marbles with a coating will yellow over time.

The Platner Tables with glass, veneer and natural marble tops are Greenguard certified.

Frame:

Vertical steel wire rods welded to circular horizontal and edge-framing rods. Finish in bright nickel with a clear lacquer protection, a painted metallic bronze, or plated in 18k gold.

Base:

Clear plastic extrusion ring for smooth bottom surface.

Glass top:

3/8" thick tempered glass for coffee and dining tables.
1/4" thick tempered glass for side tables.

Edge detail for glass:

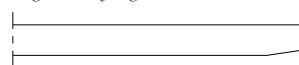

Marble Top:

All marble tops feature a bevel edge. 3/4" thick coated marble tops have transparent polyester coating to help eliminate use-associated stains. 1/4" thick natural marble tops and granite tops have protective sealer. Larger tops have subtop that fits into base opening to ensure stability.

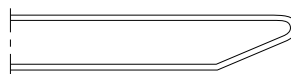

Marble edge detail:



Wood Top:

Tops are constructed of veneered medium density fiberboard with a cathedral grain pattern in various toned or stained finishes for light oak, light walnut, reff dark cherry and pearwood. Ebonized walnut features a black stain on walnut substrate. All tops are 1 1/16" thick. Edges are 1/4" solid wood to match face veneer. Wood tops are weighted with plates to ensure stability.

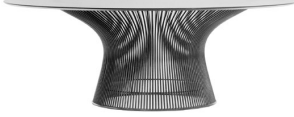
Warren Platner Coffee Tables

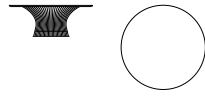
	description	base w	w	h	weight	top	
Designer(s): Warren Platner, 1962 	3712T Coffee table 	18 1/2"	36"	15 1/4"	58 lbs.	Clear glass	
		18 1/2"	36"	15 1/4"	58 lbs.	Bronze glass	
		18 1/2"	36"	15 1/4"	107 lbs.	Natural marble	
		18 1/2"	36"	15 1/4"	107 lbs.	Coated marble	
		18 1/2"	36"	15 1/4"	107 lbs.	Coated marble	
		18 1/2"	36"	15 1/4"	107 lbs.	Coated marble	
		18 1/2"	36"	15 1/4"	107 lbs.	Granite	
		18 1/2"	36"	15 1/4"	107 lbs.	Coated marble	
		18 1/2"	36"	15 1/4"	107 lbs.	Natural marble	
		18 1/2"	36"	15 1/4"	96 lbs.	Natural veneer	
		18 1/2"	36"	15 1/4"	96 lbs.	Pearwood	
		3714T Coffee table 	18 1/2"	42 1/4"	15 1/4"	71 lbs.	Clear glass
			18 1/2"	42 1/4"	15 1/4"	71 lbs.	Bronze glass
			18 1/2"	42 1/4"	15 1/4"	139 lbs.	Natural marble
			18 1/2"	42 1/4"	15 1/4"	139 lbs.	Coated marble
18 1/2"	42 1/4"		15 1/4"	139 lbs.	Coated marble		
18 1/2"	42 1/4"		15 1/4"	139 lbs.	Coated marble		
18 1/2"	42 1/4"		15 1/4"	139 lbs.	Granite		
18 1/2"	42 1/4"		15 1/4"	139 lbs.	Coated marble		
18 1/2"	42 1/4"		15 1/4"	139 lbs.	Natural marble		
18 1/2"	42 1/4"		15 1/4"	108 lbs.	Veneer		
18 1/2"	42 1/4"		15 1/4"	108 lbs.	Pearwood		

Order Code

<i>Example:</i>	3712T-BRM-NB
3712T	Platner coffee table
BRM	Metallic Bronze
NGE	Emperador Dark Marble



Note:
Platner coffee table are part of a collection. Please refer to Platner lounge seating on page 214 and Platner dining and side tables on page 366.

Specify:



1. Pattern number
2. Base finish option
3. Top option

Ordering Information

Frame:

-  Polished Nickel (suffix N)
-  Metallic Bronze (suffix BRM)
- 18k Gold Plated (suffix GLD)

Glass top finishes:

-  Clear Glass (suffix G2)
-  Bronze Glass (suffix BRG)

Veneer finishes:

- Ebonized Walnut (suffix D)
- Light Oak (suffix LO)
- Light Walnut (suffix LWA)
- Reff Dark Cherry (suffix V314)

Pearwood finish:

- Pearwood (suffix P)

Polished Coated marble top finishes:

- Arabescato: white-grey (suffix MA)
- Carrara: white-grey (suffix GC)
- Calacatta: white-grey/beige (suffix MC)
- Emperador Dark: dark brown (suffix GE)
- Empire Beige: beige (suffix GB)
- Grey Marble: light grey (suffix GG)
- Nero Marquina: black (suffix MN)
- Verde Alpi: green (suffix MV)

Satin Coated marble top finishes:



- Arabescato: white-grey (suffix MAS)
- Calacatta: white-grey/beige (suffix MCS)
- Carrara: white-grey (suffix GCS)
- Emperador Dark: dark brown (suffix GES)
- Empire Beige: beige (suffix GBS)
- Grey Marble: light grey (suffix GGS)
- Nero Marquina: black (suffix MNS)
- Verde Alpi: green (suffix MVS)

Natural marble top finishes:

- Calacatta: white-grey/beige (suffix NC)
- Carrara: white-grey (suffix NGC)
- Emperador Dark: dark brown (suffix NGE)

Granite top finish:

- Black Andes: black (suffix GA)

pattern no.	polished nickel	metallic bronze	gold plated
3712T-()-G2	\$2,305.	\$2,444.	\$3,581.
3712T-()-BRG 	2,419.	2,565.	3,758.
3712T-()-(NGC, NGE)	3,812.	4,401.	5,922.
3712T-()-(GC, GCS, GB, GBS, GE, GES)	4,292.	4,883.	6,667.
3712T-()-(MN, MNS, MA, MAS, GG, GGS)	4,479.	4,747.	6,958.
3712T-()-(MC, MCS)	4,702.	4,986.	7,304.
3712T-()-(GA)	5,543.	6,133.	8,611.
3712T-()-(MV, MVS)	5,995.	6,355.	9,312.
3712T-()-(NC)	6,598.	7,189.	10,250.
3712T-()-(LO, LWA, D, V314)	6,964.	7,382.	10,818.
3712T-()-(P)	7,484.	7,931.	11,626.
3714T-()-G2	3,021.	3,203.	4,693.
3714T-()-BRG 	3,172.	3,364.	4,928.
3714T-()-(NGC, NGE)	4,639.	5,230.	7,206.
3714T-()-(GC, GCS, GB, GBS, GE, GES)	5,258.	5,846.	8,168.
3714T-()-(MN, MNS, MA, MAS, GG, GGS)	5,443.	5,768.	8,454.
3714T-()-(MC, MCS)	6,259.	6,636.	9,723.
3714T-()-(GA)	6,808.	7,334.	10,576.
3714T-()-(MV, MVS)	7,717.	8,179.	11,987.
3714T-()-(NC)	8,200.	8,790.	12,738.
3714T-()-(LO, LWA, D, V314)	9,112.	9,658.	14,155.
3714T-()-(P)	9,758.	10,342.	15,158.

Construction

Maintenance:
See pages 28-29.

 **KnollStudio 20-Day Program:**
The Platner coffee table 3712 and 3714 in selected finishes are available on the KnollStudio 20-Day program. For specific information, consult pages 30-33.

Note:
Marbles with a coating will yellow over time.

The Platner Tables with glass, veneer and natural marble tops are Greenguard certified.

Frame:
Vertical steel wire rods welded to circular horizontal and edge-framing rods. Finish in bright nickel with a clear lacquer protection, a painted metallic bronze, or plated in 18k gold.

Base:
Clear plastic extrusion ring for smooth bottom surface.

Glass top:
3/8" thick tempered glass for coffee and dining tables.
1/4" thick tempered glass for side tables.

Edge detail for glass:

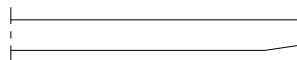

Marble Top:
All marble tops feature a bevel edge. 3/4" thick coated marble tops have transparent polyester coating to help eliminate use-associated stains. 1/4" thick natural marble tops and granite tops have protective sealer. Larger tops have subtop that fits into base opening to ensure stability.

Marble edge detail:

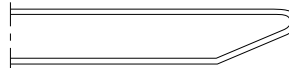





Wood Top:
Tops are constructed of veneered medium density fiberboard with a cathedral grain pattern in various toned or stained finishes for light oak, light walnut, reff dark cherry and pearwood. Ebonized walnut features a black stain on walnut substrate. All tops are 1 1/16" thick. Edges are 1/4" solid wood to match face veneer. Wood tops are weighted with plates to ensure stability.

Jens Risom

Dining and Side Tables

Designer(s):
Jens Risom, 1943



description	w	d	h	weight	base	top
642TR Round dining table 	42"	42"	28"	40 lbs.	Clear Maple	Clear Maple
	42"	42"	28"	40 lbs.	Ebonized Maple	Ebonized Walnut
	42"	42"	28"	40 lbs.	Light Walnut	Light Walnut
614TS Square side table 	14"	14"	18"	7 lbs.	Clear Maple	Clear Maple
	14"	14"	18"	7 lbs.	Ebonized Maple	Ebonized Walnut
	14"	14"	18"	7 lbs.	Light Walnut	Light Walnut
618TR Round side table 	18"	18"	20"	9 lbs.	Clear Maple	Clear Maple
	18"	18"	20"	9 lbs.	Ebonized Maple	Ebonized Walnut
	18"	18"	20"	9 lbs.	Light Walnut	Light Walnut
643TA Amoeba shaped coffee table 	42"	32"	16"	22 lbs.	Clear Maple	Clear Maple
	42"	32"	16"	22 lbs.	Ebonized Maple	Ebonized Walnut
	42"	32"	16"	22 lbs.	Light Walnut	Light Walnut

Order Code

Example:	642TR-KE-BL
642TR	Round dining table
KE	Ebonized Maple
D	Ebonized Walnut

Note:
The Risom Tables are part of a Collection. Please refer to Risom chairs on page 236 and lounge chairs on page 240.

Specify:

1. Pattern number
2. Base finish selection
3. Top finish selection

Ordering Information

Base finishes:
Clear Maple (suffix KC)
Ebonized Maple (suffix KE)
Light Walnut (suffix LWT)

Top finishes:
Clear Maple (suffix KC)
Ebonized Walnut (suffix D)
Light Walnut (suffix LWT)

Shipping information:
Dining table and Amoeba table shipped knocked down with top and legs in one box. Simple field assembly required. Side tables and coffee tables shipped fully assembled.

Maintenance:
See pages 28-29.

Note:
The Risom dining, side and amoeba tables are Greenguard certified.

Construction

Legs and aprons:
Solid maple or walnut hardwood. Mortise and tenon joints.

Top:
Tops are veneer with cathedral pattern with poplar cross bands and backing. Core and edge is solid hardwood lumber in clear finish.

Finish:
Clear lacquer or ebonized finish.

pattern no.

642TR-KC-KC	\$1,882.
642TR-KE-D	1,956.
642TR-LWT-LWT	2,054.
<hr/>	
614TS-KC-KC	876.
614TS-KE-D	909.
614TS-LWT-LWT	955.
<hr/>	
618TR-KC-KC	936.
618TR-KE-D	973.
618TR-LWT-LWT	1,023.
<hr/>	
643TA-KC-KC	1,607.
643TA-KE-D	1,673.
643TA-LWT-LWT	1,756.

Jens Risom

Child's Amoeba Table

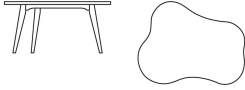
	description	w	d	h	weight	base	top
<p><i>Designer(s):</i> Jens Risom, 1943</p> 	<p>643TAS Child's Amoeba shaped coffee table</p> 	42"	32"	20"	32 lbs.	Honey Beech	Honey laminate

Order Code

<i>Example:</i>	643TAS-HB-HL
643TAS	Child's Risom Amoeba table
HB	Honey Beech
HL	Honey laminate

Note:

The Child's Risom Amoeba table is part of a Collection. Please refer to the Child's Risom side chairs on page 238.

Specify:

1. Pattern number
2. Base finish selection
3. Top finish selection

Ordering Information

<i>Base finish:</i>	Honey Beech (suffix HB)
<i>Top finish:</i>	Honey laminate (suffix HL)

Shipping information:

Child's Risom Amoeba table is shipped knocked down with top and legs in one box. Simple field assembly required.

Maintenance:

See pages 28-29.

Note:

The Child's Risom Amoeba table is compliant to the Consumer Product Safety Improvement Act of 2008 for Children's Products, 16 C.F.R. 1303, CPSIA Title 1 Section 101 for Total Lead in Substrates and Surface Coatings.

Construction

Legs and aprons:

Select European Beech hardwood with a toned natural finish. Mortise and tenon construction.

Top:

$\frac{3}{4}$ " thick wood grain laminate top is 3-ply construction with medium density fiberboard core and plastic laminate backer. Honey laminate features a Beech grain pattern.

Finish:

Toned catalyzed lacquer finish.



pattern no.

643TAS-HB-HL

\$735.

Eero Saarinen

Round Dining Tables

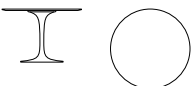
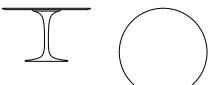
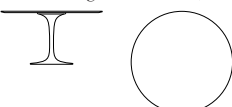
	description	w	d	h	weight	top		
Designer(s): Eero Saarinen, 1957 	172TR Small round table, dining height 	35 3/4"		28 1/4"	47 lbs.	Laminate		
		35 3/4"		28 1/4"	95 lbs.	Natural marble		
		35 3/4"		28 1/4"	95 lbs.	Coated marble		
		35 3/4"		28 1/4"	95 lbs.	Coated marble		
		35 3/4"		28 1/4"	95 lbs.	Coated marble		
		35 3/4"		28 1/4"	51 lbs.	Veneer		
		35 3/4"		28 1/4"	51 lbs.	Veneer		
		35 3/4"		28 1/4"	51 lbs.	Pearwood		
		35 3/4"		28 1/4"	103 lbs.	Granite		
		35 3/4"		28 1/4"	95 lbs.	Natural marble		
		35 3/4"		28 1/4"	95 lbs.	Coated marble		
		35 3/4"		28 1/4"	95 lbs.	Coated marble		
		173TR Medium round table, dining height 	173TR Medium round table, dining height	42 1/4"		28 1/4"	58 lbs.	Laminate
42 1/4"				28 1/4"	125 lbs.	Natural marble		
42 1/4"				28 1/4"	125 lbs.	Coated marble		
42 1/4"				28 1/4"	125 lbs.	Coated marble		
42 1/4"				28 1/4"	63 lbs.	Veneer		
42 1/4"				28 1/4"	125 lbs.	Coated marble		
42 1/4"				28 1/4"	63 lbs.	Veneer		
42 1/4"				28 1/4"	63 lbs.	Pearwood		
42 1/4"				28 1/4"	136 lbs.	Granite		
42 1/4"				28 1/4"	125 lbs.	Coated marble		
42 1/4"				28 1/4"	125 lbs.	Coated marble		
42 1/4"				28 1/4"	125 lbs.	Natural marble		
176TR Medium round table, dining height 	176TR Medium round table, dining height			47 1/4"		28 1/4"	76 lbs.	Laminate
		47 1/4"		28 1/4"	153 lbs.	Natural marble		
		47 1/4"		28 1/4"	153 lbs.	Coated marble		
		47 1/4"		28 1/4"	153 lbs.	Coated marble		
		47 1/4"		28 1/4"	74 lbs.	Veneer		
		47 1/4"		28 1/4"	153 lbs.	Coated marble		
		47 1/4"		28 1/4"	74 lbs.	Veneer		
		47 1/4"		28 1/4"	74 lbs.	Pearwood		
		47 1/4"		28 1/4"	153 lbs.	Coated marble		
		47 1/4"		28 1/4"	166 lbs.	Granite		
		47 1/4"		28 1/4"	153 lbs.	Natural marble		
		164TR Large round table, dining height 	164TR Large round table, dining height	54"		28 1/4"	102 lbs.	Laminate
				54"		28 1/4"	203 lbs.	Natural marble
54"				28 1/4"	203 lbs.	Coated marble		
54"				28 1/4"	203 lbs.	Coated marble		
54"				28 1/4"	103 lbs.	Veneer		

Order Code

Example:	176TR-MN-1
176TR	Saارين dining table
MN	Nero Marquina Marble
1	Black

Note:

Saارين tables are part of a collection. Please refer to Saارين side chairs, lounge seating, and executive chairs on beginning on page 242.

Specify:

1. Pattern number
2. Top selection
3. Base finish selection

Ordering Information

Base finishes:

Black (suffix 1)
 Platinum (suffix PL)
 White (suffix 2)

Laminate top finish:

 White (suffix F2)

Veneer finishes:

Ebonized Walnut (suffix D)
 Light Oak (suffix LO)
 Light Walnut (suffix LWA)
 Pearwood (suffix P)
 Reff Dark Cherry (suffix V314)
 Rosewood (suffix RO)
 Teak (suffix TK)

Polished Coated marble top finishes:

Arabescato: white-grey (suffix MA)
 Calacatta: white-grey/beige (suffix MC)
 Carrara: white-grey (suffix GC)
 Emperador Dark: dark brown (suffix GE)
 Empire Beige: beige (suffix GB)
 Grey Marble: light grey (suffix GG)
 Nero Marquina: black (suffix MN)
 Verde Alpi: green (suffix MV) *

Satin Coated marble top finishes:

Arabescato: white-grey (suffix MAS)
 Calacatta: white-grey/beige (suffix MCS)
 Carrara: white-grey (suffix GCS)
 Emperador Dark: dark brown (suffix GES)
 Empire Beige: beige (suffix GBS)
 Grey Marble: light grey (suffix GGS)
 Nero Marquina: black (suffix MNS)
 Verde Alpi: green (suffix MVS) *

Natural marble top finishes:

Calacatta: white-grey/beige (suffix NC)
 Carrara: white-grey (suffix NGC)
 Emperador Dark: dark brown (suffix NGE)
 NGE)



Granite top finish:

Black Andes: black (suffix GA)

* Note:

Verdi Alpi and White Extra may not be specified for 165TR.

pattern no.

172TR-F2-(1, 2, PL)	\$2,931.
172TR-(NGC, NGE)-(1, 2, PL)	3,681.
172TR-(GC, GCS, GB, GBS, GE, GES)-(1, 2, PL)	4,164.
172TR-(MN, MNS, MA, MAS, GG, GGS)-(1, 2, PL)	4,475.
172TR-(MC, MCS)-(1, 2, PL)	4,902.
172TR-(LO, LWA, D, V314)-(1, 2, PL)	4,958.
172TR-(RO, TK)-(1, 2, PL)	5,046.
172TR-(P)-(1, 2, PL)	5,368.
172TR-(GA)-(1, 2, PL)	5,497.
172TR-(NC)-(1, 2, PL)	6,555.
172TR-(MV, MVS)-(1, 2, PL)	6,562.
172TR-(MW)-(1, 2, PL)	7,546.
173TR-F2-(1, 2, PL) 	3,127.
173TR-(NGC, NGE)-(1, 2, PL)	4,509.
173TR-(GC, GCS, GB, GBS, GE, GES)-(1, 2, PL)	5,127.
173TR-(MN, MNS, MA, MAS, GG, GGS)-(1, 2, PL)	5,220.
173TR-(RO, TK)-(1, 2, PL)	5,525.
173TR-(MC, MCS)-(1, 2, PL)	5,720.
173TR-(LO, LWA, D, V314)-(1, 2, PL)	5,963.
173TR-(P)-(1, 2, PL)	6,490.
173TR-(GA)-(1, 2, PL)	6,699.
173TR-(MV, MVS)-(1, 2, PL)	7,032.
173TR-(MW)-(1, 2, PL)	8,087.
173TR-(NC)-(1, 2, PL)	8,156.
176TR-F2-(1, 2, PL) 	3,357.
176TR-(NGC, NGE)-(1, 2, PL)	4,794.
176TR-(GC, GCS, GB, GBS, GE, GES)-(1, 2, PL)	5,507.
176TR-(MN, MNS, MA, MAS, GG, GGS)-(1, 2, PL)	5,606.
176TR-(RO, TK)-(1, 2, PL)	5,859.
176TR-(MC, MCS)-(1, 2, PL)	6,144.
176TR-(LO, LWA, D, V314)-(1, 2, PL)	6,674.
176TR-(P)-(1, 2, PL)	7,288.
176TR-(MV, MVS)-(1, 2, PL)	7,499.
176TR-(GA)-(1, 2, PL)	7,660.
176TR-(NC)-(1, 2, PL)	9,592.
164TR-F2-(1, 2, PL) 	4,469.
164TR-(NGC, NGE)-(1, 2, PL)	6,416.
164TR-(GC, GCS, GB, GBS, GE, GES)-(1, 2, PL)	7,381.
164TR-(MN, MNS, MA, MAS, GG, GGS)-(1, 2, PL)	7,537.
164TR-(RO, TK)-(1, 2, PL)	8,179.

Construction

 **KnollStudio 20-Day Program:**
Saarinen dining table 164TR, 173TR, 176TR is available on the KnollStudio 20-Day program with a white base and white laminate top. For specific information, consult pages 30-33.

Maintenance:
See pages 28-29.

Note:
Top and base shipped in separate packages. The Knoll logo is stamped into the base of the Saarinen tables. Tops have nameplate with designer's signature.
Not suitable for outdoor use.

Marbles with a coating will yellow over time.

Saarinen Dining Tables with Laminate, Natural Marble, Veneer or Granite tops are Greenguard certified.

Base:
Heavy molded cast aluminum, strap-polished. Black and white bases are coated in a tough, abrasion-resistant Rilsan finish. Platinum bases consist of a highly resilient polyurethane enamel wet coat with a clear satin finish.

Base Measurements:
172TR, 173TR, 176TR: 20" diameter
164TR, 165TR: 25.984" diameter

Marble and Laminate Tops:
Bevel-edged satin smooth laminate or marble. 3/8" thick coated marble tops have transparent polyester coating to help eliminate use-associated stains. 3/4" thick natural marble tops and granite tops have protective sealer. Laminate tops are 1.06" thick.

Laminate edge detail:

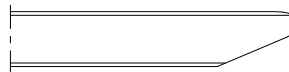

Marble edge detail:

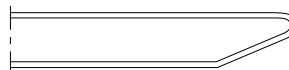

Wood Top:
Tops are constructed of veneered medium density fiberboard with a cathedral grain pattern in various clear or toned stains. All tops are 1 1/16" thick with the exception of 164TR and 165TR which are 1 1/4" thick. Edges are 1/4" solid wood to match face veneer.

Engineered Stone:
Polished, bright white surface is nonporous and more compact than most granites. Comprised of 93% fused quartz. It does not yellow or stain and is scratch resistant. Suitable for outdoors.

Note:
Vetro Bianco (VBO) top for outdoor use is only available on 173TR and 169TR tables. 173TR uses a phenolic subtop. Stainless steel hardware will be used for all connections.

Eero Saarinen

Round Dining Tables

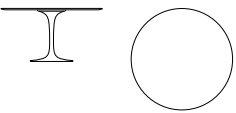
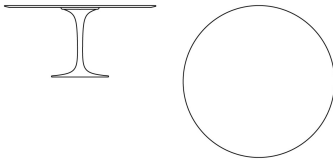
	description	w	d	h	weight	top
<p><i>Designer(s):</i> Eero Saarinen, 1957</p> 	<p>164TR Large round table, dining height</p> 	54"		28 1/4"	203 lbs.	Coated marble
		54"		28 1/4"	103 lbs.	Veneer
		54"		28 1/4"	103 lbs.	Pearwood
		54"		28 1/4"	218 lbs.	Granite
		54"		28 1/4"	203 lbs.	Coated marble
		54"		28 1/4"	203 lbs.	Coated marble
		54"		28 1/4"	203 lbs.	Natural marble
	<p>165TR Large round table, dining height</p> 	60"		28 1/4"	115 lbs.	Laminate
		60"		28 1/4"	244 lbs.	Natural marble
		60"		28 1/4"	244 lbs.	Coated marble
		60"		28 1/4"	121 lbs.	Veneer
		60"		28 1/4"	121 lbs.	Veneer
		60"		28 1/4"	121 lbs.	Pearwood
		60"		28 1/4"	263 lbs.	Granite
60"			28 1/4"	244 lbs.	Coated marble	
60"			28 1/4"	244 lbs.	Coated marble	
60"			28 1/4"	244 lbs.	Natural marble	

Order Code

<i>Example:</i>	176TR-MN-1
176TR	Saarinen dining table
MN	Nero Marquina Marble
1	Black

Note:

Saarinen tables are part of a collection. Please refer to Saarinen side chairs, lounge seating, and executive chairs on beginning on page 242.

Specify:

1. Pattern number
2. Top selection
3. Base finish selection

Ordering Information

Base finishes:

Black (suffix 1)
Platinum (suffix PL)
 White (suffix 2)

Laminate top finish:

 White (suffix F2)

Veneer finishes:

Ebonized Walnut (suffix D)
Light Oak (suffix LO)
Light Walnut (suffix LWA)
Pearwood (suffix P)
Reff Dark Cherry (suffix V314)
Rosewood (suffix R0)
Teak (suffix TK)

Polished Coated marble top finishes:

Arabescato: white-grey (suffix MA)
Calacatta: white-grey/beige (suffix MC)
Carrara: white-grey (suffix GC)
Emperador Dark: dark brown (suffix GE)
Empire Beige: beige (suffix GB)
Grey Marble: light grey (suffix GG)
Nero Marquina: black (suffix MN)
Verde Alpi: green (suffix MV) *

Satin Coated marble top finishes:

Arabescato: white-grey (suffix MAS)
Calacatta: white-grey/beige (suffix MCS)
Carrara: white-grey (suffix GCS)
Emperador Dark: dark brown (suffix GES)
Empire Beige: beige (suffix GBS)
Grey Marble: light grey (suffix GGS)
Nero Marquina: black (suffix MNS)
Verde Alpi: green (suffix MVS) *

Natural marble top finishes:

Calacatta: white-grey/beige (suffix NC)
Carrara: white-grey (suffix NGC)
Emperador Dark: dark brown (suffix NGE)

Granite top finish:

Black Andes: black (suffix GA)

* Note:

Verdi Alpi and White Extra may not be specified for 165TR.

pattern no.

164TR-(MC, MCS)-(1, 2, PL)	\$8,261.
164TR-(LO, LWA, D, V314)-(1, 2, PL)	8,359.
164TR-(P)-(1, 2, PL)	9,096.
164TR-(GA)-(1, 2, PL)	9,279.
164TR-(MV, MVS)-(1, 2, PL)	10,129.
164TR-(MW)-(1, 2, PL)	11,648.
164TR-(NC)-(1, 2, PL)	12,428.
165TR-F2-(1, 2, PL)	6,978.
165TR-(NGC, NGE)-(1, 2, PL)	7,354.
165TR-(GC, GCS, GB, GBS, GE, GES)-(1, 2, PL)	8,544.
165TR-(RO, TK)-(1, 2, PL)	8,708.
165TR-(LO, LWA, D, V314)-(1, 2, PL)	9,088.
165TR-(P)-(1, 2, PL)	9,869.
165TR-(GA)-(1, 2, PL)	11,140.
165TR-(MN, MNS, MA, MAS, GG, GGS)-(1, 2, PL)	11,596.
165TR-(MC, MCS)-(1, 2, PL)	12,698.
165TR-(NC)-(1, 2, PL)	14,917.

Construction

 **KnollStudio 20-Day Program:** Saarinen dining table 164TR, 173TR, 176TR is available on the KnollStudio 20-Day program with a white base and white laminate top. For specific information, consult pages 30-33.

Maintenance:
See pages 28-29.

Note:
Top and base shipped in separate packages. The Knoll logo is stamped into the base of the Saarinen tables. Tops have nameplate with designer's signature.
Not suitable for outdoor use.

Marbles with a coating will yellow over time.

Saarinen Dining Tables with Laminate, Natural Marble, Veneer or Granite tops are Greenguard certified.

Base:
Heavy molded cast aluminum, strap-polished. Black and white bases are coated in a tough, abrasion-resistant Rilsan finish. Platinum bases consist of a highly resilient polyurethane enamel wet coat with a clear satin finish.

Base Measurements:
172TR, 173TR, 176TR: 20" diameter
164TR, 165TR: 25.984" diameter

Marble and Laminate Tops:
Bevel-edged satin smooth laminate or marble. $\frac{3}{8}$ " thick coated marble tops have transparent polyester coating to help eliminate use-associated stains. $\frac{3}{4}$ " thick natural marble tops and granite tops have protective sealer. Laminate tops are 1.06" thick.

Laminate edge detail:

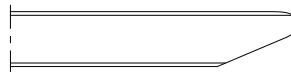

Marble edge detail:

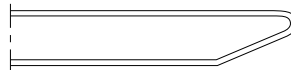



Wood Top:
Tops are constructed of veneered medium density fiberboard with a cathedral grain pattern in various clear or toned stains. All tops are $1\frac{1}{16}$ " thick with the exception of 164TR and 165TR which are $1\frac{1}{4}$ " thick. Edges are $\frac{1}{4}$ " solid wood to match face veneer.

Engineered Stone:
Polished, bright white surface is nonporous and more compact than most granites. Comprised of 93% fused quartz. It does not yellow or stain and is scratch resistant. Suitable for outdoors.

Note:
Vetro Bianco (VBO) top for outdoor use is only available on 173TR and 169TR tables. 173TR uses a phenolic subtop. Stainless steel hardware will be used for all connections.

Eero Saarinen

Oval Dining Tables

	description	w	d	h	weight	top	
<p><i>Designer(s):</i> Eero Saarinen, 1957</p> 	<p>174TO Medium oval table, dining height</p> 	78"	47 3/4"	28 1/4"	131 lbs.	Laminate	
		78"	47 3/4"	28 1/4"	259 lbs.	Natural marble	
		78"	47 3/4"	28 1/4"	259 lbs.	Coated marble	
		78"	47 3/4"	28 1/4"	131 lbs.	Veneer	
		78"	47 3/4"	28 1/4"	131 lbs.	Veneer	
		78"	47 3/4"	28 1/4"	259 lbs.	Coated marble	
		78"	47 3/4"	28 1/4"	229 lbs.	Granite	
		78"	47 3/4"	28 1/4"	131 lbs.	Pearwood	
		78"	47 3/4"	28 1/4"	259 lbs.	Coated marble	
		78"	47 3/4"	28 1/4"	259 lbs.	Natural marble	
		78"	47 3/4"	28 1/4"	259 lbs.	Coated marble	
		 <p>175TO Large oval table, dining height</p>	96"	54"	28 1/4"	169 lbs.	Laminate
			96"	54"	28 1/4"	348 lbs.	Natural marble
96"	54"		28 1/4"	168 lbs.	Veneer		
96"	54"		28 1/4"	348 lbs.	Coated marble		
96"	54"		28 1/4"	168 lbs.	Veneer		
96"	54"		28 1/4"	348 lbs.	Vetro Bianco		
96"	54"		28 1/4"	348 lbs.	Coated marble		
96"	54"		28 1/4"	168 lbs.	Pearwood		
96"	54"		28 1/4"	374 lbs.	Granite		
96"	54"		28 1/4"	348 lbs.	Coated marble		
96"	54"		28 1/4"	348 lbs.	Natural marble		
96"	54"		28 1/4"	348 lbs.	Coated marble		

Order Code

<i>Example:</i>	174TO-MA-PL
174TO	Saarinen dining table
MA	Arabescato Marble
PL	Platinum

Note:

Saarinen tables are part of a collection. Please refer to Saarinen side chairs, lounge seating, and executive chairs on beginning on page 242.

Specify:

1. Pattern number
2. Top selection
3. Base finish selection

Ordering Information

Base finishes:

Black (suffix 1)
Platinum (suffix PL)
White (suffix 2)

Laminate top finish:

White (suffix F2)

Veneer finishes:

Ebonized Walnut (suffix D)
Light Oak (suffix LO)
Light Walnut (suffix LWA)
Pearwood (suffix P)
Reff Dark Cherry (suffix V314)
Rosewood (suffix RO)
Teak (suffix TK)

Polished Coated marble top finishes:

Arabescato: white-grey (suffix MA)
Calacatta: white-grey/beige (suffix MC)
Carrara: white-grey (suffix GC)
Emperador Dark: dark brown (suffix GE)
Empire Beige: beige (suffix GB)
Grey Marble: light grey (suffix GG)
Nero Marquina: black (suffix MN)
Verde Alpi: green (suffix MV)

Satin Coated marble top finishes:

Arabescato: white-grey (suffix MAS)
Calacatta: white-grey/beige (suffix MCS)
Carrara: white-grey (suffix GCS)
Emperador Dark: dark brown (suffix GES)
Empire Beige: beige (suffix GBS)
Grey Marble: light grey (suffix GGS)
Nero Marquina: black (suffix MNS)
Verde Alpi: green (suffix MVS)

Natural marble top finishes:

Calacatta: white-grey/beige (suffix NC)
Carrara: white-grey (suffix NGC)
Emperador Dark: dark brown (suffix NGE)

Granite top finish:

Black Andes: black (suffix GA)

Engineered Stone:

Vetro Bianco (suffix VB)

pattern no.

174TO-F2-(1, 2, PL)	\$7,696.
174TO-(NGC, NGE)-(1, 2, PL)	7,859.
174TO-(GC, GCS, GB, GBS, GE, GES)-(1, 2, PL)	9,207.
174TO-(RO, TK)-(1, 2, PL)	9,794.
174TO-(LO, LWA, D, V314)-(1, 2, PL)	11,429.
174TO-(MN, MNS, MA, MAS, GG, GGS)-(1, 2, PL)	11,901.
174TO-(GA)-(1, 2, PL)	11,920.
174TO-(P)-(1, 2, PL)	12,438.
174TO-(MC, MCS)-(1, 2, PL)	13,030.
174TO-(NC)-(1, 2, PL)	15,373.
174TO-(MV, MVS)-(1, 2, PL)	17,479.
175TO-F2-(1, 2, PL)	8,711.
175TO-(NGC, NGE)-(1, 2, PL)	9,882.
175TO-(RO, TK)-(1, 2, PL)	10,825.
175TO-(GC, GCS, GB, GBS, GE, GES)-(1, 2, PL)	11,755.
175TO-(LO, LWA, D, V314)-(1, 2, PL)	12,725.
175TO-(VB)-(1, 2, PL)	13,259.
175TO-(MN, MNS, MA, MAS, GG, GGS)-(1, 2, PL)	13,669.
175TO-(P)-(1, 2, PL)	13,891.
175TO-(GA)-(1, 2, PL)	14,400.
175TO-(MC, MCS)-(1, 2, PL)	14,965.
175TO-(NC)-(1, 2, PL)	19,751.
175TO-(MV, MVS)-(1, 2, PL)	20,085.

Construction

Maintenance:
See pages 28-29.

Note:
Top and base shipped in separate packages. The Knoll logo is stamped into the base of the Saarinen tables. Tops have nameplate with designer's signature.

Not suitable for outdoor use.

Marbles with a coating will yellow over time.

Saarinen Dining Tables with Laminate, Natural Marble, Veneer or Granite tops are Greenguard certified.

Base:
Heavy molded cast aluminum, strap-polished. Black and white bases are coated in a tough, abrasion-resistant Rilsan finish. Platinum bases consist of a highly resilient polyurethane enamel wet coat with a clear satin finish.

Base Measurements:
174TO, 175TO: width is 31.3" and depth is 23"

Marble and Laminate Tops:
Bevel-edged satin smooth laminate or marble. 3/4" thick coated marble tops have transparent polyester coating to help eliminate use-associated stains. 3/4" thick natural marble tops and granite tops have protective sealer. Laminate tops are 1.06" thick.

Laminate edge detail:

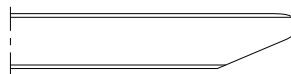

Marble edge detail:

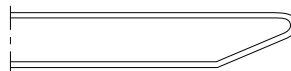





Engineered Stone:
Polished, bright white surface is nonporous and more compact than most granites. Comprised of 93% fused quartz. It does not yellow or stain and is scratch resistant.

Veneer Tops:
Tops are constructed of veneered medium density fiberboard with a cathedral grain pattern in various clear or toned stains. Oval dining tops are 1 1/4" thick. Edges are 1/4" solid wood to match face veneer.

Eero Saarinen

Round End and Coffee Tables

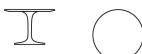
	description	w	d	h	weight	top		
Designer(s): Eero Saarinen, 1957 	160TR Small round side table, intermediate height 	16 1/4"		20"	12 lbs.	Laminate		
		16 1/4"		20"	21 lbs.	Natural marble		
		16 1/4"		20"	21 lbs.	Coated marble		
		16 1/4"		20"	21 lbs.	Coated marble		
		16 1/4"		20"	21 lbs.	Coated marble		
		16 1/4"		20"	21 lbs.	Vetro Bianco		
		16 1/4"		20"	25 lbs.	Granite		
		16 1/4"		20"	21 lbs.	Natural marble		
		16 1/4"		20"	14 lbs.	Veneer		
		16 1/4"		20"	14 lbs.	Pearwood		
		16 1/4"		20"	14 lbs.	Veneer		
			162TR Medium round coffee table, low level 	35 3/4"		15 1/4"	40 lbs.	Laminate
				35 3/4"		15 1/4"	88 lbs.	Natural marble
35 3/4"				15 1/4"	88 lbs.	Coated marble		
35 3/4"				15 1/4"	43 lbs.	Veneer		
35 3/4"				15 1/4"	43 lbs.	Veneer		
35 3/4"				15 1/4"	88 lbs.	Coated marble		
35 3/4"				15 1/4"	43 lbs.	Pearwood		
35 3/4"				15 1/4"	88 lbs.	Coated marble		
35 3/4"				15 1/4"	96 lbs.	Granite		
35 3/4"				15 1/4"	88 lbs.	Coated marble		
35 3/4"				15 1/4"	88 lbs.	Natural marble		
163TR Small round side table, intermediate height 	163TR Small round side table, intermediate height			20"		20"	16 lbs.	Laminate
				20"		20"	30 lbs.	Natural marble
		20"		20"	30 lbs.	Coated marble		
		20"		20"	30 lbs.	Coated marble		
		20"		20"	30 lbs.	Coated marble		
		20"		20"	30 lbs.	Coated marble		
		20"		20"	17 lbs.	Veneer		
		20"		20"	33 lbs.	Granite		
		20"		20"	30 lbs.	Natural marble		
		20"		20"	17 lbs.	Pearwood		
		20"		20"	17 lbs.	Veneer		
		169TR Small round side table, low height 	169TR Small round side table, low height	20"		13 3/4"	14 lbs.	Laminate
				20"		13 3/4"	29 lbs.	Natural marble
20"				13 3/4"	29 lbs.	Coated marble		
20"				13 3/4"	29 lbs.	Coated marble		
20"				13 3/4"	29 lbs.	Coated marble		
20"				13 3/4"	29 lbs.	Coated marble		
20"				13 3/4"	29 lbs.	Coated marble		

Order Code

<i>Example:</i>	160TR-MV-2
161TO	Saarinen side table
MV	Verdi Alpi Marble
2	White

Note:

Saarinen tables are part of a collection. Please refer to Saarinen side chairs, lounge seating and executive chairs on pages 242.

Specify:

1. Pattern number
2. Top selection
3. Base finish selection

Ordering Information

Base finishes:

Black (suffix 1)
 Platinum (suffix PL)
 White (suffix 2)

Laminate top finish:

 White (suffix F2)

Veneer Finishes:

Ebonized Walnut (suffix D)
 Light Oak (suffix LO)
 Light Walnut (suffix LWA)
 Reff Dark Cherry (suffix V314)
 Pearwood (suffix P)
 Rosewood (suffix RO)
 Teak (suffix TK)

Polished Coated marble top finishes:

Arabescato: white-grey (suffix MA)
 Calacatta: white-grey/beige (suffix MC)
 Carrara: white-grey (suffix GC)
 Emperador Dark: dark brown (suffix GE)
 Empire Beige: beige (suffix GB)
 Grey Marble: light grey (suffix GG)
 Nero Marquina: black (suffix MN)
 Verde Alpi: green (suffix MV)

Satin Coated marble top finishes:

Arabescato: white-grey (suffix MAS)
 Calacatta: white-grey/beige (suffix MCS)
 Carrara: hite-grey (suffix GCS)
 Emperador Dark: dark brown (suffix GES)
 Empire Beige: beige (suffix GBS)
 Grey Marble: light grey (suffix GGS)
 Nero Marquina: black (suffix MNS)
 Verde Alpi: green (suffix MVS)

Natural marble top finishes:

Calacatta: white-grey/beige (suffix NC)
 Carrara: white-grey (suffix NGC)
 Emperador Dark: dark brown (suffix NGE)

Granite top finish:

Black Andes: black (suffix GA)



Engineered Stone:

Vetro Bianco (suffix VB)

KnollStudio 20-Day Program:

Saarinen 169TR and 163TR side tables are available on the KnollStudio 20-day program in select finishes. For specific information, consult pages 30-33.

pattern no.

160TR-F2-(1, 2, PL)	\$904.
160TR-(NGC, NGE)-(1, 2, PL)	1,088.
160TR-(GC, GCS, GB, GBS, GE, GES)-(1, 2, PL)	1,192.
160TR-(MN, MNS, MA, MAS, GG, GGS)-(1, 2, PL)	1,251.
160TR-(MC, MCS)-(1, 2, PL)	1,313.
160TR-(MV, MVS)-(1, 2, PL)	1,564.
160TR-(VB)-(1, 2, PL)	1,585.
160TR-(GA)-(1, 2, PL)	2,070.
160TR-(NC)-(1, 2, PL)	2,105.
160TR-(LO, LWA, D, V314)-(1, 2, PL)	2,130.
160TR-(P)-(1, 2, PL)	2,428.
160TR-(RO, TK)-(1, 2, PL)	2,894.
162TR-F2-(1, 2, PL)	2,454.
162TR-(NGC, NGE)-(1, 2, PL)	2,786.
162TR-(GC, GCS, GB, GBS, GE, GES)-(1, 2, PL)	3,267.
162TR-(LO, LWA, D, V314)-(1, 2, PL)	3,614.
162TR-(RO, TK)-(1, 2, PL)	4,093.
162TR-(MN, MNS, MA, MAS, GG, GGS)-(1, 2, PL)	4,121.
162TR-(P)-(1, 2, PL)	4,129.
162TR-(MC, MCS)-(1, 2, PL)	4,327.
162TR-(GA)-(1, 2, PL)	4,826.
162TR-(MV, MVS)-(1, 2, PL)	5,609.
162TR-(NC)-(1, 2, PL)	5,881.
163TR-F2-(1, 2, PL) 	1,064.
163TR-(NGC, NGE)-(1, 2, PL)	1,187.
163TR-(GC, GCS, GB, GBS, GE, GES)-(1, 2, PL)	1,336.
163TR-(MN, MNS, MA, MAS, GG, GGS)-(1, 2, PL)	1,442.
163TR-(MC, MCS)-(1, 2, PL)	1,513.
163TR-(MV, MVS)-(1, 2, PL)	2,051.
163TR-(LO, LWA, D, V314)-(1, 2, PL)	2,266.
163TR-(GA)-(1, 2, PL)	2,451.
163TR-(NC)-(1, 2, PL)	2,487.
163TR-(P)-(1, 2, PL)	2,589.
163TR-(TK, RO)-(1, 2, PL)	2,996.
169TR-F2-(1,2, PL) 	976.
169TR-(NGC, NGE)-(1, 2, PL)	1,158.
169TR-(GC, GCS, GB, GBS, GE, GES)-(1, 2, PL)	1,297.
169TR-(MN, MNS, MA, MAS, GG, GGS)-(1, 2, PL)	1,401.
169TR-(MC, MCS)-(1, 2, PL)	1,472.
169TR-(MV, MVS)-(1, 2, PL)	1,860.

Construction

Maintenance:
See pages 28-29.

Note:
Top and base shipped in separate packages. The Knoll logo is stamped into the base of the Saarinen tables. Tops have a nameplate with the designers signature.

Not suitable for outdoor use.

Marbles with a coating will yellow over time.

Saarinen Round End and Coffee Tables with Laminate, Natural Marble, Veneer or Granite tops are Greenguard certified.

Base:
Heavy molded cast aluminum, strap-polished. Black and white bases are coated in a tough, abrasion-resistant Rilsan finish. Platinum bases consist of a highly resilient polyurethane enamel wet coat with a clear satin finish.

Base Diameters:
160TR, 163TR: 10.7"
162TR: 17"
169TR: 13.5"

Laminate and Marble Tops:
Bevel-edged satin smooth laminate or marble. 3/4" thick coated marble tops have transparent polyester coating to help eliminate use-associated stains. 3/4" thick natural marble tops and granite tops have protective sealer. Laminate tops are 1.06" thick.

Laminate edge detail:

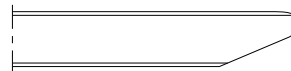

Marble edge detail:

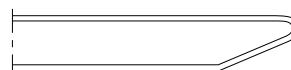

Veneer Tops:
Tops are constructed of veneered medium density fiberboard with a cathedral grain pattern in various clear or toned or stains. All tops are 1/2" thick.

Engineered Stone:
Polished, bright white surface is nonporous and more compact than most granites. Comprised of 93% fused quartz. It does not yellow or stain and is scratch resistant. Suitable for outdoors.

Note:
Vetro Bianco (VBO) top for outdoor use is only available on 173TR and 169TR tables. 173TR uses a phenolic subtop. Stainless steel hardware will be used for all connections.

Eero Saarinen

Round End and Coffee Tables

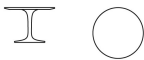
	description	w	d	h	weight	top
<i>Designer(s):</i> Eero Saarinen, 1957	169TR Small round side table, low height 	20"		13 3/4"	16 lbs.	Veneer
		20"		13 3/4"	32 lbs.	Granite
		20"		13 3/4"	29 lbs.	Natural marble
		20"		13 3/4"	16 lbs.	Pearwood
		20"		13 3/4"	16 lbs.	Veneer



Order Code

<i>Example:</i>	160TR-MV-2
161TO	Saارين side table
MV	Verdi Alpi Marble
2	White

Note:

Saارين tables are part of a collection. Please refer to Saارين side chairs, lounge seating and executive chairs on pages 242.

Specify:

1. Pattern number
2. Top selection
3. Base finish selection

Ordering Information

Base finishes:

Black (suffix 1)
 Platinum (suffix PL)
 White (suffix 2)

Laminate top finish:

 White (suffix F2)

Veneer Finishes:

Ebonized Walnut (suffix D)
 Light Oak (suffix LO)
 Light Walnut (suffix LWA)
 Reff Dark Cherry (suffix V314)
 Pearwood (suffix P)
 Rosewood (suffix RO)
 Teak (suffix TK)

Polished Coated marble top finishes:

Arabescato: white-grey (suffix MA)
 Calacatta: white-grey/beige (suffix MC)
 Carrara: white-grey (suffix GC)
 Emperador Dark: dark brown (suffix GE)
 Empire Beige: beige (suffix GB)
 Grey Marble: light grey (suffix GG)
 Nero Marquina: black (suffix MN)
 Verde Alpi: green (suffix MV)

Satin Coated marble top finishes:

Arabescato: white-grey (suffix MAS)
 Calacatta: white-grey/beige (suffix MCS)
 Carrara: hite-grey (suffix GCS)
 Emperador Dark: dark brown (suffix GES)
 Empire Beige: beige (suffix GBS)
 Grey Marble: light grey (suffix GGS)
 Nero Marquina: black (suffix MNS)
 Verde Alpi: green (suffix MVS)

Natural marble top finishes:

Calacatta: white-grey/beige (suffix NC)
 Carrara: white-grey (suffix NGC)
 Emperador Dark: dark brown (suffix NGE)

Granite top finish:

Black Andes: black (suffix GA)

Engineered Stone:

Vetro Bianco (suffix VB)

KnollStudio 20-Day Program:

Saارين 169TR and 163TR side tables are available on the KnollStudio 20-day program in select finishes. For specific information, consult pages 30-33.

pattern no.

169TR-(LO, LWA, D, V314)-(1, 2, PL) 	\$2,370.
169TR-(GA)-(1, 2, PL)	2,403.
169TR-(NC)-(1, 2, PL)	2,438.
169TR-(P)-(1, 2, PL)	2,697.
169TR-(RO, TK)-(1, 2, PL)	3,067.

Construction

Maintenance:
See pages 28-29.

Note:
Top and base shipped in separate packages. The Knoll logo is stamped into the base of the Saarinen tables. Tops have a nameplate with the designers signature.

Not suitable for outdoor use.

Marbles with a coating will yellow over time.

Saarinen Round End and Coffee Tables with Laminate, Natural Marble, Veneer or Granite tops are Greenguard certified.

Base:
Heavy molded cast aluminum, strap-polished. Black and white bases are coated in a tough, abrasion-resistant Rilsan finish. Platinum bases consist of a highly resilient polyurethane enamel wet coat with a clear satin finish.

Base Diameters:
160TR, 163TR: 10.7"
162TR: 17"
169TR: 13.5"

Laminate and Marble Tops:
Bevel-edged satin smooth laminate or marble. 3/4" thick coated marble tops have transparent polyester coating to help eliminate use-associated stains. 3/4" thick natural marble tops and granite tops have protective sealer. Laminate tops are 1.06" thick.

Laminate edge detail:

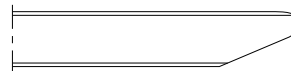

Marble edge detail:

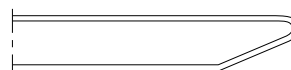





Veneer Tops:
Tops are constructed of veneered medium density fiberboard with a cathedral grain pattern in various clear or toned or stains. All tops are 1 1/16" thick.

Engineered Stone:
Polished, bright white surface is nonporous and more compact than most granites. Comprised of 93% fused quartz. It does not yellow or stain and is scratch resistant. Suitable for outdoors.

Note:
Vetro Bianco (VBO) top for outdoor use is only available on 173TR and 169TR tables. 173TR uses a phenolic subtop. Stainless steel hardware will be used for all connections.

Eero Saarinen

Oval End and Coffee Tables

	description	w	d	h	weight	top		
<p><i>Designer(s):</i> Eero Saarinen, 1957</p> 	<p>161TO Oval side table, intermediate height</p> 	22 1/2"	15"	20"	15 lbs.	Laminate		
		22 1/2"	15"	20"	28 lbs.	Natural marble		
		22 1/2"	15"	20"	28 lbs.	Coated marble		
		22 1/2"	15"	20"	28 lbs.	Coated marble		
		22 1/2"	15"	20"	28 lbs.	Coated marble		
		22 1/2"	15"	20"	28 lbs.	Coated marble		
		22 1/2"	15"	20"	16 lbs.	Veneer		
		22 1/2"	15"	20"	29 lbs.	Granite		
		22 1/2"	15"	20"	28 lbs.	Natural marble		
		22 1/2"	15"	20"	16 lbs.	Pearwood		
		22 1/2"	15"	20"	16 lbs.	Veneer		
			<p>162TO Oval coffee table, low level</p> 	42 1/4"	27 1/2"	15 1/4"	37 lbs.	Laminate
				42 1/4"	27 1/2"	15 1/4"	80 lbs.	Natural marble
42 1/4"	27 1/2"			15 1/4"	80 lbs.	Coated marble		
42 1/4"	27 1/2"			15 1/4"	40 lbs.	Veneer		
42 1/4"	27 1/2"			15 1/4"	80 lbs.	Coated marble		
42 1/4"	27 1/2"			15 1/4"	80 lbs.	Coated marble		
42 1/4"	27 1/2"			15 1/4"	40 lbs.	Veneer		
42 1/4"	27 1/2"			15 1/4"	40 lbs.	Pearwood		
42 1/4"	27 1/2"			15 1/4"	86 lbs.	Granite		
42 1/4"	27 1/2"			15 1/4"	80 lbs.	Coated marble		
42 1/4"	27 1/2"			15 1/4"	80 lbs.	Natural marble		

Order Code

<i>Example:</i>	161TO-NGC-2
161TO	Saarinen side table
NGC	Carrara Marble
2	White

Note:
Saarinen tables are part of a collection. Please refer to Saarinen side chairs, lounge seating and executive chairs on pages 242.

Specify:

1. Pattern number
2. Top selection
3. Base finish selection

Ordering Information

Base finishes:

Black (suffix 1)
Platinum (suffix PL)
White (suffix 2)

Laminate top finish:

White (suffix F2)

Veneer Finishes:

Ebonized Walnut (suffix D)
Light Oak (suffix LO)
Light Walnut (suffix LWA)
Pearwood (suffix P)
Reff Dark Cherry (suffix V314)
Rosewood (suffix RO)
Teak (suffix TK)

Polished Coated marble top finishes:

Arabescato: white-grey (suffix MA)
Calacatta: white-grey/beige (suffix MC)
Carrara: white-grey (suffix GC)
Emperador Dark: dark brown (suffix GE)
Empire Beige: beige (suffix GB)
Grey Marble: light grey (suffix GG)
Nero Marquina: black (suffix MN)
Verde Alpi: green (suffix MV)

Satin Coated marble top finishes:

Arabescato: white-grey (suffix MAS)
Calacatta: white-grey/beige (suffix MCS)
Carrara: white-grey (suffix GCS)
Emperador Dark: dark brown (suffix GES)
Empire Beige: beige (suffix GBS)
Grey Marble: light grey (suffix GGS)
Nero Marquina: black (suffix MNS)
Verde Alpi: green (suffix MVS)

Natural marble top finishes:

Calacatta: white-grey/beige (suffix NC)
Carrara: white-grey (suffix NGC)
Emperador Dark: dark brown (suffix NGE)

Granite top finish:

Black Andes: black (suffix GA)

pattern no.

161TO-F2-(1, 2, PL)	\$1,091.
161TO-(NGC, NGE)-(1, 2, PL)	1,095.
161TO-(GC, GCS, GB, GBS, GE, GES)-(1, 2, PL)	1,201.
161TO-(MN, MNS, MA, MAS, GG, GGS)-(1, 2, PL)	1,235.
161TO-(MC, MCS)-(1, 2, PL)	1,296.
161TO-(MV, MVS)-(1, 2, PL)	1,467.
161TO-(LO, LWA, D, V314)-(1, 2, PL)	2,367.
161TO-(GA)-(1, 2, PL)	2,388.
161TO-(NC)-(1, 2, PL)	2,442.
161TO-(P)-(1, 2, PL)	2,707.
161TO-(RO, TK)-(1, 2, PL)	2,942.
162TO-F2-(1, 2, PL)	2,465.
162TO-(NGC, NGE)-(1, 2, PL)	3,115.
162TO-(GC, GCS, GB, GBS, GE, GES)-(1, 2, PL)	3,537.
162TO-(LO, LWA, D, V314)-(1, 2, PL)	3,614.
162TO-(MN, MNS, MA, MAS, GG, GGS)-(1, 2, PL)	3,717.
162TO-(MC, MCS)-(1, 2, PL)	3,904.
162TO-(RO, TK)-(1, 2, PL)	3,995.
162TO-(P)-(1, 2, PL)	4,130.
162TO-(GA)-(1, 2, PL)	4,918.
162TO-(MV, MVS)-(1, 2, PL)	5,082.
162TO-(NC)-(1, 2, PL)	6,126.

Construction

Maintenance:

See pages 28-29.

Note:

Top and base shipped in separate packages. The Knoll logo is stamped into the base of the Saarinen tables. Tops have a nameplate with the designers signature.

Not suitable for outdoor use.

Marbles with a coating will yellow over time.

Saarinen Oval End and Coffee Tables with Laminate, Natural Marble, Veneer or Granite tops are Greenguard certified.

Base:

Heavy molded cast aluminum, strap-polished. Black and white bases are coated in a tough, abrasion-resistant Rilsan finish. Platinum bases consist of a highly resilient polyurethane enamel wet coat with a clear satin finish.

Base Diameters:

161TO: 10.7"

162TO: 17"

Laminate and Marble Tops:

Bevel-edged satin smooth laminate or marble. $\frac{3}{4}$ " thick coated marble tops have transparent polyester coating to help eliminate use-associated stains. $\frac{3}{4}$ " thick natural marble tops and granite tops have protective sealer. Laminate tops are 1.06" thick.

Laminate edge detail:

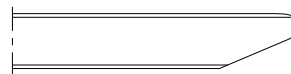

Marble edge detail:

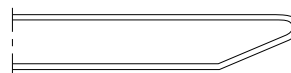

Veneer Tops:

Tops are constructed of veneered medium density fiberboard with a cathedral grain pattern in various clear or toned or stains. All tops are $1\frac{1}{16}$ " thick.

Eero Saarinen Outdoor Tables

Designer(s):
Eero Saarinen, 1957

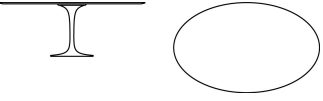
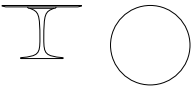
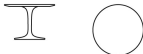

description	w	d	h	weight	top
174TO Medium oval table, dining height 	78"	47 1/4"	28 3/4"	259 lbs.	Vetro Bianco
173TR Medium round table, dining height 	42 1/4"		28 3/4"	125 lbs.	Vetro Bianco
	42 1/4"		28 3/4"	125 lbs.	Slate, natural
169TR Small round side table, low height 	20"		13 3/4"	29 lbs.	Vetro Bianco

Order Code

<i>Example:</i>	173TR-VBO-2
173TR	Saarinen dining table
VBO	Vetro Bianco
2	White

Note:
Saarinen tables are part of a collection. Please refer to Saarinen side chairs, lounge seating, and executive chairs on beginning on page 242.

Specify:

1. Pattern number
2. Top selection
3. Base finish selection

Ordering Information

Base finishes:
 White (suffix 2)
 Black (suffix 1) *
***Available on slate table only.**

Engineered Stone:
Vetro Bianco (suffix VBO)

Slate top finish:
Slate, natural (suffix SNO)

Maintenance:
See pages 28-29.

Note:
Top and base shipped in separate packages. The Knoll logo is stamped into the base of the Saarinen tables. Tops have nameplate with designer's signature.

Construction

Base:
Heavy molded cast aluminum, strap-polished. White bases are coated in a tough, abrasion-resistant Rilsan finish.

Base Measurements:
 174TO: 31.3"W x 23"D
 173TR: 20" diameter
 169TR: 13.5" diameter

Tops:
3/4" thick bevel-edged Vetro Bianco or Slate top.

Edge detail:





Engineered Stone:
Polished, bright white surface is nonporous and more compact than most granites. Comprised of 93% fused quartz. It does not yellow or stain and is scratch resistant. Exposed black phenolic sub-top edge with white laminate faces. Suitable for outdoors.

Slate:
Beveled edge, 3/4" thick natural cleft slate. Black phenolic sub-top with black laminate faces. Suitable for outdoor use.

pattern no.	list
174TO-(VBO)-2	\$10,885.
173TR-(VBO)-2	5,553.
173TR-(SNO)-(1,2)	6,329.
169TR-(VBO)-2	1,429.

Richard Schultz

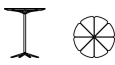
Petal® Table Collection

	description	w	d	h	weight	top	
<p><i>Designer(s):</i> Richard Schultz, 1960</p> 	P320 Petal end table	16"		19"	5 lbs.	Teak	
			16"		19"	5 lbs.	White HPDE
	P320COV Petal end table cover	–		–	–	–	–
	P321 Petal coffee table	42"		15"	60 lbs.	Teak	
			42"		15"	60 lbs.	White HPDE
	P321COV Petal coffee table cover	–		–	–	–	–
	P322 Petal dining table	42"		28"	62 lbs.	Teak	
			42"		28"	62 lbs.	White HPDE
	P322COV Petal dining table cover	–		–	–	–	–

Order Code

<i>Example:</i>	P320-K-W
P320	Petal side table
K	Teak top
W	White

Specify:

1. Pattern number
2. Top selection
3. Base finish selection

Ordering Information

Base finishes:
 Blue (suffix BLU)
 Chestnut (suffix N)
 Dark Bronze (suffix 14)
 Green (suffix 007)
 Light Bronze (suffix 13)
 Lime Green (suffix LGR)
 Onyx (suffix O)
 Orange (suffix ORG)
 Plum (suffix PLM)
 Sky Blue (suffix 3)
 Warm Bronze (suffix 16)
 Warm Wood (suffix 12)
 Weatherable Silver (suffix S)
 White (suffix W)
 Yellow (suffix YEL)

Wood top finishes:
 Teak (suffix K)

High Density Polyurethane top finishes:
 White HPDE (suffix W)

Maintenance:
 See pages 28-29.

Construction

Base:
 Top spider and base are powder coated cast aluminum. Stem is powder coated stainless steel.

Wood top:
 Vertical grain teak with natural finish.

HPDE top:
 Machined high density polyurethane.

pattern no.

P320-K-()	\$1,472.
P320-W-()	1,343.

P320COV	386.
P321-K-()	3,329.
P321-W-()	3,213.

P321COV	581.
P322-K-()	3,445.
P322-W-()	3,329.

P322COV	610.
----------------	------

Note:

Teak tops will patina over time if left outdoors and will turn a silvery grey color.

Glides:



Molded nylon glides are included on P321 and P322 models only.

Richard Schultz

1966 Collection® Dining Tables

Designer(s):
Richard Schultz, 1966

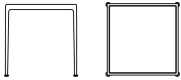
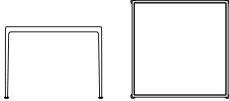
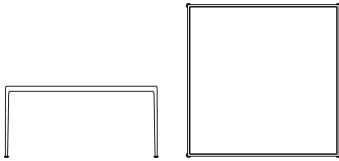
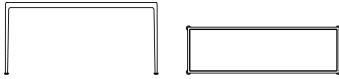
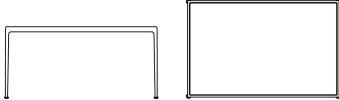

description	w	d	h	weight	top
1966-24H 1966 Dining Table 	28"	28"	28"	39 lbs.	Glass
	28"	28"	28"	36 lbs.	Porcelain
	28"	28"	28"	38 lbs.	Teak
	28"	28"	28"	37 lbs.	Fiberglass
1966-24HCOV 1966 Dining Table cover	–	–	–	–	–
1966-26H 1966 Dining Table 	38"	38"	28"	63 lbs.	Glass
	38"	38"	28"	50 lbs.	Porcelain
	38"	38"	28"	50 lbs.	Teak
	38"	38"	28"	49 lbs.	Fiberglass
1966-26HCOV 1966 Dining Table cover	–	–	–	–	–
1966-60H 1966 Dining Table 	60"	60"	28"	143 lbs.	Glass
	60"	60"	28"	131 lbs.	Porcelain
	60"	60"	28"	120 lbs.	Teak
	60"	60"	28"	106 lbs.	Fiberglass
1966-60HCOV 1966 Dining Table cover	–	–	–	–	–
1966-20H 1966 Dining Table 	60"	18"	28"	50 lbs.	Glass
	60"	18"	28"	61 lbs.	Porcelain
	60"	18"	28"	53 lbs.	Teak
	60"	18"	28"	47 lbs.	Fiberglass
1966-20HCOV 1966 Dining Table cover	–	–	–	–	–
1966-28H 1966 Dining Table 	60"	38"	28"	91 lbs.	Glass
	60"	38"	28"	93 lbs.	Porcelain
	60"	38"	28"	77 lbs.	Teak
	60"	38"	28"	71 lbs.	Fiberglass
1966-28HCOV 1966 Dining Table cover	–	–	–	–	–
1966-90H 1966 Dining Table 	90"	38"	28"	137 lbs.	Glass
	90"	38"	28"	TBD lbs.	Porcelain
	90"	38"	28"	115 lbs.	Teak
	90"	38"	28"	110 lbs.	Fiberglass
1966-90HCOV 1966 Dining Table cover	–	–	–	–	–

Order Code

<i>Example:</i>	1966-24H-P-W-W
1966-24H	28" x 28" dining table
P	Porcelain top
W	White top
W	White frame

Specify:

1. Pattern number
2. Top material
3. Top finish selection
4. Base finish selection

Ordering Information

Base finishes:

Blue (suffix BLU)
Chestnut (suffix N)
Dark Bronze (suffix 14)
Green (suffix 007)
Light Bronze (suffix 13)
Lime Green (suffix LGR)
Onyx (suffix O)
Orange (suffix ORG)
Plum (suffix PLM)
Sky Blue (suffix 3)
Warm Bronze (suffix 16)
Warm Wood (suffix 12)
Weatherable Silver (suffix S)
White (suffix W)
Yellow (suffix YEL)

Porcelain top finishes:

White (suffix W)
Brown (suffix B)
Marine Blue (suffix M)
Warm Wood (suffix 12)
Light Bronze (suffix 13)
Dark Bronze (suffix 14)
Warm Bronze (suffix 16)

Fiberglass top finishes:

White (suffix W)

Glass top finishes:

Clear glass (suffix C)
Etched glass (suffix E)

pattern no.

1966-24H-G-()-()	\$2,089.
1966-24H-P-()-()	2,701.
1966-24H-K-()	2,813.
1966-24H-F-()-()	2,924.
<hr/>	
1966-24HCOV	589.
1966-26H-G-()-()	2,757.
1966-26H-P-()-()	3,287.
1966-26H-K-()	3,760.
1966-26H-F-()-()	4,038.
<hr/>	
1966-26HCOV	700.
1966-60H-G-()-()	4,846.
1966-60H-P-()-()	5,681.
1966-60H-K-()	6,322.
1966-60H-F-()-()	6,740.
<hr/>	
1966-60HCOV	877.
1966-20H-G-()-()	2,350.
1966-20H-P-()-()	2,963.
1966-20H-K-()	3,075.
1966-20H-F-()-()	3,186.
<hr/>	
1966-20HCOV	683.
1966-28H-G-()-()	3,175.
1966-28H-P-()-()	3,899.
1966-28H-K-()	4,624.
1966-28H-F-()-()	4,846.
<hr/>	
1966-28HCOV	796.
1966-90H-G-()-()	4,512.
1966-90H-P-()-()	5,517.
1966-90H-K-()	5,987.
1966-90H-F-()-()	6,406.
<hr/>	
1966-90HCOV	1,033.

Construction*Wood top finishes:*

Teak (suffix K)

High Density Polyurethane top finishes:

White HPDE (suffix W)

Maintenance:

See pages 28-29.

Frame:

Frame is aluminum castings and extrusions welded together. Finished in highly durable weather resistant polyester powder coat paint. Y-shaped stainless steel connectors attach tops on corners.

Glass Top:

$\frac{3}{8}$ " beveled glass top available in clear or acid etched.

Porcelain Top:

.08" thick steel plate with a porcelain enamel layer comprised of glass particles, baked to melt into a .002" smooth surface. Honey comb subtup comprised of metal or particle wood board provides additional support.

Teak:

1" natural teak.

Fiberglass Top:

1" thick fiberglass available in white finish.

Note:

Teak tops will patina over time if left outdoors and will turn a silvery grey color.

Glides:

Clear butyrate plastic.

Richard Schultz

1966 Collection® Counter Height Tables

Designer(s):
Richard Schultz, 1966

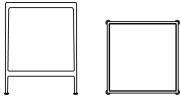
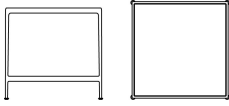
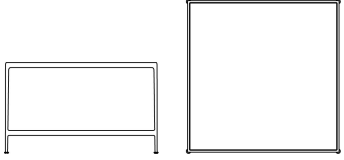
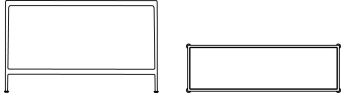
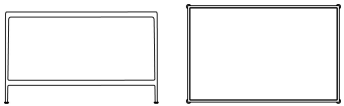

description	w	d	h	weight	top
1966-24C 1966 Counter Height Table 	28"	28"	36"	47 lbs.	Glass
	28"	28"	36"	41 lbs.	Porcelain
	28"	28"	36"	44 lbs.	Teak
	28"	28"	36"	36 lbs.	Fiberglass
1966-24CCOV 1966 Counter Height Table cover	–	–	–	–	–
1966-26C 1966 Counter Height Table 	38"	38"	36"	71 lbs.	Glass
	38"	38"	36"	55 lbs.	Porcelain
	38"	38"	36"	56 lbs.	Teak
	38"	38"	36"	47 lbs.	Fiberglass
1966-26CCOV 1966 Counter Height Table cover	–	–	–	–	–
1966-60C 1966 Counter Height Table 	60"	60"	36"	151 lbs.	Glass
	60"	60"	36"	141 lbs.	Porcelain
	60"	60"	36"	129 lbs.	Teak
	60"	60"	36"	106 lbs.	Fiberglass
1966-60CCOV 1966 Counter Height Table cover	–	–	–	–	–
1966-20C 1966 Counter Height Table 	60"	18"	36"	58 lbs.	Glass
	60"	18"	36"	69 lbs.	Porcelain
	60"	18"	36"	61 lbs.	Teak
	60"	18"	36"	45 lbs.	Fiberglass
1966-20CCOV 1966 Counter Height Table cover	–	–	–	–	–
1966-28C 1966 Counter Height Table 	60"	38"	36"	100 lbs.	Glass
	60"	38"	36"	102 lbs.	Porcelain
	60"	38"	36"	86 lbs.	Teak
	60"	38"	36"	66 lbs.	Fiberglass
1966-28CCOV 1966 Counter Height Table cover	–	–	–	–	–

Order Code

<i>Example:</i>	1966-26C-K-O
1966-26C	38" x 38" counter height table
K	Teak top
O	Onyx frame

Specify:

1. Pattern number
2. Top material
3. Top finish selection
4. Base finish selection

Ordering Information

Base finishes:

Blue (suffix BLU)
Chestnut (suffix N)
Dark Bronze (suffix 14)
Green (suffix 007)
Light Bronze (suffix 13)
Lime Green (suffix LGR)
Onyx (suffix O)
Orange (suffix ORG)
Plum (suffix PLM)
Sky Blue (suffix 3)
Warm Bronze (suffix 16)
Warm Wood (suffix 12)
Weatherable Silver (suffix S)
White (suffix W)
Yellow (suffix YEL)

Porcelain top finishes:

White (suffix W)
Brown (suffix B)
Marine Blue (suffix M)
Warm Wood (suffix 12)
Light Bronze (suffix 13)
Dark Bronze (suffix 14)
Warm Bronze (suffix 16)

Fiberglass top finishes:

White (suffix W)

Glass top finishes:

Clear glass (suffix C)
Etched glass (suffix E)

pattern no.

1966-24C-G-()-()	\$2,562.
1966-24C-P-()-()	3,175.
1966-24C-K-()	3,287.
1966-24C-F-()-()	3,398.
1966-24CCOV	683.
1966-26C-G-()-()	3,230.
1966-26C-P-()-()	3,760.
1966-26C-K-()	4,233.
1966-26C-F-()-()	4,512.
1966-26CCOV	794.
1966-60C-G-()-()	5,681.
1966-60C-P-()-()	6,517.
1966-60C-K-()	7,156.
1966-60C-F-()-()	7,575.
1966-60CCOV	999.
1966-20C-G-()-()	2,824.
1966-20C-P-()-()	3,436.
1966-20C-K-()	3,547.
1966-20C-F-()-()	3,659.
1966-20CCOV	776.
1966-28C-G-()-()	3,787.
1966-28C-P-()-()	4,512.
1966-28C-K-()	5,235.
1966-28C-F-()-()	5,458.
1966-28CCOV	888.

Construction

Wood top finishes:

Teak (suffix K)

High Density Polyurethane top finishes:

White HPDE (suffix W)

Maintenance:

See pages 28-29.

Frame:

Frame is aluminum castings and extrusions welded together. Finished in highly durable weather resistant polyester powder coat paint. Y-shaped stainless steel connectors attach tops on corners.

Glass Top:

$\frac{3}{8}$ " beveled glass top available in clear or acid etched.

Porcelain Top:

.08" thick steel plate with a porcelain enamel layer comprised of glass particles, baked to melt into a .002" smooth surface. Honey comb subtop comprised of metal or particle wood board provides additional support.

Teak:

1" natural teak.

Fiberglass Top:

1" thick fiberglass available in white finish.

Note:

Teak tops will patina over time if left outdoors and will turn a silvery grey color.

Glides:

Clear butyrate plastic.

Richard Schultz

1966 Collection® Bar Height Tables

Designer(s):
Richard Schultz, 1966

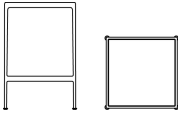
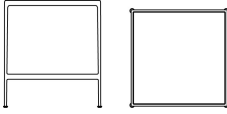
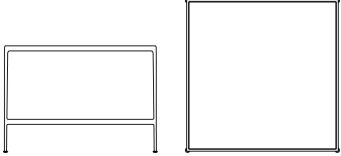
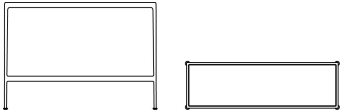
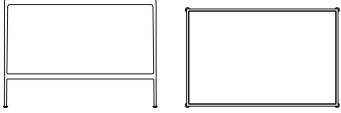

description	w	d	h	weight	top
1966-24B 1966 Bar Height Table 	28"	28"	42"	49 lbs.	Glass
	28"	28"	42"	44 lbs.	Porcelain
	28"	28"	42"	47 lbs.	Teak
	28"	28"	42"	39 lbs.	Fiberglass
1966-24BCOV 1966 Bar Height Table cover	–	–	–	–	–
1966-26B 1966 Bar Height Table 	38"	38"	42"	73 lbs.	Glass
	38"	38"	42"	58 lbs.	Porcelain
	38"	38"	42"	59 lbs.	Teak
	38"	38"	42"	50 lbs.	Fiberglass
1966-26BCOV 1966 Bar Height Table cover	–	–	–	–	–
1966-60B 1966 Bar Height Table 	60"	60"	42"	153 lbs.	Glass
	60"	60"	42"	145 lbs.	Porcelain
	60"	60"	42"	133 lbs.	Teak
	60"	60"	42"	110 lbs.	Fiberglass
1966-60BCOV 1966 Bar Height Table cover	–	–	–	–	–
1966-20B 1966 Bar Height Table 	60"	18"	42"	60 lbs.	Glass
	60"	18"	42"	71 lbs.	Porcelain
	60"	18"	42"	63 lbs.	Teak
	60"	18"	42"	48 lbs.	Fiberglass
1966-20BCOV 1966 Bar Height Table cover	–	–	–	–	–
1966-28B 1966 Bar Height Table 	60"	38"	42"	103 lbs.	Glass
	60"	38"	42"	105 lbs.	Porcelain
	60"	38"	42"	89 lbs.	Teak
	60"	38"	42"	70 lbs.	Fiberglass
1966-28BCOV 1966 Bar Height Table cover	–	–	–	–	–

Order Code

<i>Example:</i>	1966-20B-F-W-6
1966-20B	60" x 18" bar height table
F	Fiberglass top
W	White top
6	Choice White frame

Specify:

1. Pattern number
2. Top material
3. Top finish selection
4. Base finish selection

Ordering Information

Base finishes:

Blue (suffix BLU)
Chestnut (suffix N)
Dark Bronze (suffix 14)
Green (suffix 007)
Light Bronze (suffix 13)
Lime Green (suffix LGR)
Onyx (suffix O)
Orange (suffix ORG)
Plum (suffix PLM)
Sky Blue (suffix 3)
Warm Bronze (suffix 16)
Warm Wood (suffix 12)
Weatherable Silver (suffix S)
White (suffix W)
Yellow (suffix YEL)

Porcelain top finishes:

White (suffix W)
Brown (suffix B)
Marine Blue (suffix M)
Warm Wood (suffix 12)
Light Bronze (suffix 13)
Dark Bronze (suffix 14)
Warm Bronze (suffix 16)

Fiberglass top finishes:

White (suffix W)

Glass top finishes:

Clear glass (suffix C)
Etched glass (suffix E)

pattern no.

1966-24B-G-(-)(-)	\$2,674.
1966-24B-P-(-)(-)	3,287.
1966-24B-K-(-)	3,398.
1966-24B-F-(-)(-)	3,509.

1966-24BCOV	751.
1966-26B-G-(-)(-)	3,342.
1966-26B-P-(-)(-)	3,871.
1966-26B-K-(-)	4,345.
1966-26B-F-(-)(-)	4,624.

1966-26BCOV	882.
1966-60B-G-(-)(-)	5,793.
1966-60B-P-(-)(-)	6,628.
1966-60B-K-(-)	7,269.
1966-60B-F-(-)(-)	7,686.

1966-60BCOV	1,104.
1966-20B-G-(-)(-)	2,936.
1966-20B-P-(-)(-)	3,547.
1966-20B-K-(-)	3,659.
1966-20B-F-(-)(-)	3,771.

1966-20BCOV	869.
1966-28B-G-(-)(-)	3,899.
1966-28B-P-(-)(-)	4,624.
1966-28B-K-(-)	5,347.
1966-28B-F-(-)(-)	5,570.

1966-28BCOV	987.
-------------	------

Construction

Wood top finishes:

Teak (suffix K)

High Density Polyurethane top finishes:

White HPDE (suffix W)

Maintenance:

See pages 28-29.

Frame:

Frame is aluminum castings and extrusions welded together. Finished in highly durable weather resistant polyester powder coat paint. Y-shaped stainless steel connectors attach tops on corners.

Glass Top:

$\frac{3}{8}$ " beveled glass top available in clear or acid etched.

Porcelain Top:

.08" thick steel plate with a porcelain enamel layer comprised of glass particles, baked to melt into a .002" smooth surface. Honey comb subtop comprised of metal or particle wood board provides additional support.

Teak:

1" natural teak.

Fiberglass Top:

1" thick fiberglass available in white finish.

Note:

Teak tops will patina over time if left outdoors and will turn a silvery grey color.

Glides:





Clear butyrate plastic.

Richard Schultz

1966 Collection® End and Coffee Tables

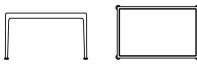
Designer(s):
Richard Schultz, 1966

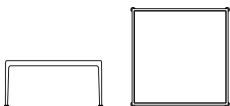
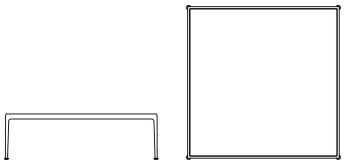

description	w	d	h	weight	top
1966-18L 1966 End Table 	18"	18"	15"	17 lbs.	Glass
	18"	18"	15"	16 lbs.	Porcelain
	18"	18"	15"	24 lbs.	Teak
	18"	18"	15"	17 lbs.	Fiberglass
1966-18LCOV 1966 End Table cover	–	–	–	–	–
1966-19L 1966 Coffee Table 	32"	20"	15"	28 lbs.	Glass
	32"	20"	15"	23 lbs.	Porcelain
	32"	20"	15"	27 lbs.	Teak
	32"	20"	15"	24 lbs.	Fiberglass
1966-19LCOV 1966 Coffee Table cover	–	–	–	–	–
1966-24L 1966 Coffee Table 	28"	28"	15"	34 lbs.	Glass
	28"	28"	15"	30 lbs.	Porcelain
	28"	28"	15"	28 lbs.	Teak
	28"	28"	15"	31 lbs.	Fiberglass
1966-24LCOV 1966 Coffee Table cover	–	–	–	–	–
1966-26L 1966 Coffee Table 	38"	38"	15"	57 lbs.	Glass
	38"	38"	15"	44 lbs.	Porcelain
	38"	38"	15"	44 lbs.	Teak
	38"	38"	15"	43 lbs.	Fiberglass
1966-26LCOV 1966 Coffee Table cover	–	–	–	–	–
1966-60L 1966 Coffee Table 	60"	60"	15"	133 lbs.	Glass
	60"	60"	15"	127 lbs.	Porcelain
	60"	60"	15"	108 lbs.	Teak
	60"	60"	15"	100 lbs.	Fiberglass
1966-60LCOV 1966 Coffee Table cover	–	–	–	–	–
1966-20L 1966 Coffee Table 	60"	18"	15"	44 lbs.	Glass
	60"	18"	15"	55 lbs.	Porcelain
	60"	18"	15"	47 lbs.	Teak
	60"	18"	15"	40 lbs.	Fiberglass
1966-20LCOV 1966 Coffee Table cover	–	–	–	–	–

Order Code

Example: **1966-18L-G-E-S**

1966-18L	18" x 18" end table
G	Glass top
E	Etched glass top
S	Weatherable Silver frame

Specify:

1. Pattern number
2. Top material
3. Top finish selection
4. Base finish selection

Ordering Information

Base finishes:

Blue (suffix BLU)
Chestnut (suffix N)
Dark Bronze (suffix 14)
Green (suffix 007)
Light Bronze (suffix 13)
Lime Green (suffix LGR)
Onyx (suffix O)
Orange (suffix ORG)
Plum (suffix PLM)
Sky Blue (suffix 3)
Warm Bronze (suffix 16)
Warm Wood (suffix 12)
Weatherable Silver (suffix S)
White (suffix W)
Yellow (suffix YEL)

Porcelain top finishes:

White (suffix W)
Brown (suffix B)
Marine Blue (suffix M)
Warm Wood (suffix 12)
Light Bronze (suffix 13)
Dark Bronze (suffix 14)
Warm Bronze (suffix 16)

Fiberglass top finishes:

White (suffix W)

Glass top finishes:

Clear glass (suffix C)
Etched glass (suffix E)

pattern no.

1966-18L-G-()-()	\$1,643.
1966-18L-P-()-()	1,872.
1966-18L-K-()	1,933.
1966-18L-F-()-()	1,988.
1966-18LCOV	264.
1966-19L-G-()-()	1,921.
1966-19L-P-()-()	2,172.
1966-19L-K-()	2,295.
1966-19L-F-()-()	2,406.
1966-19LCOV	430.
1966-24L-G-()-()	1,894.
1966-24L-P-()-()	2,507.
1966-24L-K-()	2,618.
1966-24L-F-()-()	2,730.
1966-24LCOV	589.
1966-26L-G-()-()	2,507.
1966-26L-P-()-()	3,035.
1966-26L-K-()	3,509.
1966-26L-F-()-()	3,787.
1966-26LCOV	598.
1966-60L-G-()-()	4,512.
1966-60L-P-()-()	5,347.
1966-60L-K-()	5,987.
1966-60L-F-()-()	6,406.
1966-60LCOV	808.
1966-20L-G-()-()	2,211.
1966-20L-P-()-()	2,824.
1966-20L-K-()	2,936.
1966-20L-F-()-()	3,047.
1966-20LCOV	614.

Construction

Wood top finishes:

Teak (suffix K)

High Density Polyurethane top finishes:

White HPDE (suffix W)

Maintenance:

See pages 28-29.

Frame:

Frame is aluminum castings and extrusions welded together. Finished in highly durable weather resistant polyester powder coat paint. Y-shaped stainless steel connectors attach tops on corners.

Glass Top:

$\frac{3}{8}$ " beveled glass top available in clear or acid etched.

Porcelain Top:

.08" thick steel plate with a porcelain enamel layer comprised of glass particles, baked to melt into a .002" smooth surface. Honey comb subtop comprised of metal or particle wood board provides additional support.

Teak:

1" natural teak.

Fiberglass Top:

1" thick fiberglass available in white finish.

Note:





Teak tops will patina over time if left outdoors and will turn a silvery grey color.

Glides:

Clear butyrate plastic.

Richard Schultz

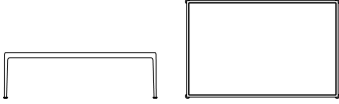
1966 Collection® End and Coffee Tables

	description	w	d	h	weight	top
<i>Designer(s):</i> Richard Schultz, 1966  	1966-28L 1966 Coffee Table 	60"	38"	15"	85 lbs.	Glass
		60"	38"	15"	87 lbs.	Porcelain
		60"	38"	15"	71 lbs.	Teak
		60"	38"	15"	65 lbs.	Fiberglass
		<hr/>				
	1966-28LCOV 1966 Coffee Table cover	–	–	–	–	–
	1966-90L 1966 Coffee Table 	90"	38"	15"	132 lbs.	Glass
		90"	38"	15"	TBD lbs.	Porcelain
		90"	38"	15"	105 lbs.	Teak
		90"	38"	15"	100 lbs.	Fiberglass
<hr/>						
	1966-90LCOV 1966 Coffee Table cover	–	–	–	–	–

Order Code

<i>Example:</i>	1966-18L-G-E-S
1966-18L	18" x 18" end table
G	Glass top
E	Etched glass top
S	Weatherable Silver frame

Specify:

1. Pattern number
2. Top material
3. Top finish selection
4. Base finish selection

Ordering Information

Base finishes:

Blue (suffix BLU)
 Chestnut (suffix N)
 Dark Bronze (suffix 14)
 Green (suffix 007)
 Light Bronze (suffix 13)
 Lime Green (suffix LGR)
 Onyx (suffix O)
 Orange (suffix ORG)
 Plum (suffix PLM)
 Sky Blue (suffix 3)
 Warm Bronze (suffix 16)
 Warm Wood (suffix 12)
 Weatherable Silver (suffix S)
 White (suffix W)
 Yellow (suffix YEL)

Porcelain top finishes:

White (suffix W)
 Brown (suffix B)
 Marine Blue (suffix M)
 Warm Wood (suffix 12)
 Light Bronze (suffix 13)
 Dark Bronze (suffix 14)
 Warm Bronze (suffix 16)

Fiberglass top finishes:

White (suffix W)

Glass top finishes:

Clear glass (suffix C)
 Etched glass (suffix E)

pattern no.

1966-28L-G-(-)(-)	\$2,841.
1966-28L-P-(-)(-)	3,565.
1966-28L-K-(-)	4,289.
1966-28L-F-(-)(-)	4,512.
<hr/>	
1966-28LCOV	773.
1966-90L-G-(-)(-)	4,233.
1966-90L-P-(-)(-)	5,092.
1966-90L-K-(-)	5,708.
1966-90L-F-(-)(-)	6,126.
<hr/>	
1966-90LCOV	981.

Construction

Wood top finishes:

Teak (suffix K)

High Density Polyurethane top finishes:

White HPDE (suffix W)

Maintenance:

See pages 28-29.

Frame:

Frame is aluminum castings and extrusions welded together. Finished in highly durable weather resistant polyester powder coat paint. Y-shaped stainless steel connectors attach tops on corners.

Glass Top:

$\frac{3}{8}$ " beveled glass top available in clear or acid etched.

Porcelain Top:

.08" thick steel plate with a porcelain enamel layer comprised of glass particles, baked to melt into a .002" smooth surface. Honey comb subtop comprised of metal or particle wood board provides additional support.

Teak:

1" natural teak.

Fiberglass Top:

1" thick fiberglass available in white finish.

Note:

Teak tops will patina over time if left outdoors and will turn a silvery grey color.

Glides:

Clear butyrate plastic.

Richard Schultz

1966 Collection® Serving Cart

Designer(s):
Richard Schultz, 1966

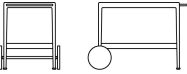

description	w	d	h	weight	top
1966-55 Serving cart	23 1/2"	39"	26 1/4"	55 lbs.	Porcelain
	23 1/2"	39"	26 1/4"	61 lbs.	Teak
	23 1/2"	39"	26 1/4"	61 lbs.	Fiberglass
1966-55COV Serving cart cover					

Order Code

<i>Example:</i>	1966-55-P-M-W
1966-55	Serving Cart
P	Porcelain top
M	Marine Blue top
W	White frame

Specify:

1. Pattern number
2. Top material
3. Top finish selection
4. Base finish selection

Ordering Information

Base finishes:

Blue (suffix BLU)
Chestnut (suffix N)
Dark Bronze (suffix 14)
Green (suffix 007)
Light Bronze (suffix 13)
Lime Green (suffix LGR)
Onyx (suffix O)
Orange (suffix ORG)
Plum (suffix PLM)
Sky Blue (suffix 3)
Warm Bronze (suffix 16)
Warm Wood (suffix 12)
Weatherable Silver (suffix S)
White (suffix W)
Yellow (suffix YEL)

Porcelain top finishes:

White (suffix W)
Brown (suffix B)
Marine Blue (suffix M)
Warm Wood (suffix 12)
Light Bronze (suffix 13)
Dark Bronze (suffix 14)
Warm Bronze (suffix 16)

Fiberglass top finishes:

White (suffix W)

pattern no.

1966-55-P-()-()	\$4,192.
1966-55-K-()	5,049.
1966-55-F-()-()	5,255.
1966-55COV	700.

Construction

Wood top finishes:
Teak (suffix K)

High Density Polyurethane top finishes:
White HPDE (suffix W)

Maintenance:
See pages 28-29.

Frame:
Frame is aluminum castings and extrusions welded together. Finished in highly durable weather resistant polyester powder coat paint. Y-shaped stainless steel connectors attach tops on corners. Wheels are cast aluminum with rubber tires and a differential axle.

Porcelain Top:
.08" thick steel plate with a porcelain enamel layer comprised of glass particles, baked to melt into a .002" smooth surface. Honey comb subtop comprised of metal or particle wood board provides additional support.

Teak:
1" natural teak.

Fiberglass Top:
1" thick fiberglass available in white finish.

Note:
Teak tops will patina over time if left outdoors and will turn a silvery grey color.



Glides:
Clear butyrate plastic.

Richard Schultz

Fresh Air Dining Tables

Designer(s):
Richard Schultz, 2011

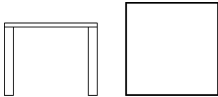
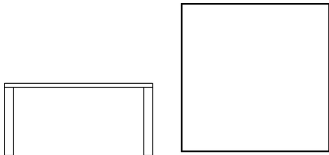
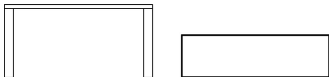
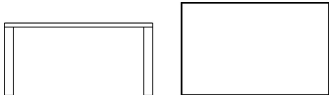

description	w	d	h	weight	top
FA-26H Fresh Air dining table 	36 3/4"	36 3/4"	28 3/8"	90 lbs.	Glass
	36 3/4"	36 3/4"	28 3/8"	88 lbs.	Porcelain
	36 3/4"	36 3/4"	28 3/8"	90 lbs.	Teak
FA-26HCOV Fresh Air dining table cover					
FA-60H Fresh Air dining table 	58 3/4"	58 3/4"	28 3/8"	168 lbs.	Glass
	58 3/4"	58 3/4"	28 3/8"	177 lbs.	Porcelain
	58 3/4"	58 3/4"	28 3/8"	158 lbs.	Teak
FA-60HCOV Fresh Air dining table cover					
FA-20H Fresh Air dining table 	58 3/4"	16 3/4"	28 3/8"	78 lbs.	Glass
	58 3/4"	16 3/4"	28 3/8"	88 lbs.	Porcelain
	58 3/4"	16 3/4"	28 3/8"	81 lbs.	Teak
FA-20HCOV Fresh Air dining table cover					
FA-28H Fresh Air dining table 	58 3/4"	36 3/4"	28 3/8"	120 lbs.	Glass
	58 3/4"	36 3/4"	28 3/8"	120 lbs.	Porcelain
	58 3/4"	36 3/4"	28 3/8"	104 lbs.	Teak
FA-28HCOV Fresh Air dining table cover					
FA-90H Fresh Air dining table 	88 3/4"	36 3/4"	28 3/8"	162 lbs.	Glass
	88 3/4"	36 3/4"	28 3/8"	TBD lbs.	Porcelain
	88 3/4"	36 3/4"	28 3/8"	156 lbs.	Teak
FA-90HCOV Fresh Air dining table cover					

Order Code

<i>Example:</i>	FA-20H-G-C-14
FA-20H	58 3/4" x 16 3/4" dining table
G	Glass top
C	Clear glass top
14	Dark Bronze frame

Specify:

1. Pattern number
2. Top material
3. Top finish selection
4. Base finish selection

Ordering Information

Base finishes:

Blue (suffix BLU)
Chestnut (suffix N)
Choice White (suffix 6)
Daffodil Yellow (suffix 2)
Dark Bronze (suffix 14)
Forest Green (suffix 1)
Green (suffix 007)
Light Bronze (suffix 13)
Lime Green (suffix LGR)
Onyx (suffix O)
Orange (suffix ORG)
Plum (suffix PLM)
Sky Blue (suffix 3)
Terra Cotta (suffix 5)
Warm Bronze (suffix 16)
Warm Wood (suffix 12)
Weatherable Silver (suffix S)
White (suffix W)
Yellow (suffix YEL)

Porcelain top finishes:

White (suffix W)
Brown (suffix B)
Marine Blue (suffix M)
Warm Wood (suffix 12)
Light Bronze (suffix 13)
Dark Bronze (suffix 14)
Warm Bronze (suffix 16)

Glass top finishes:

Clear glass (suffix C)
Etched glass (suffix E)

pattern no.

FA-26H-G-()-()	\$2,339.
FA-26H-P-()-()	2,952.
FA-26H-K-()	3,064.

FA-26HCOV	701.
FA-60H-G-()-()	4,010.
FA-60H-P-()-()	4,735.
FA-60H-K-()	5,458.

FA-60HCOV	882.
FA-20H-G-()-()	2,144.
FA-20H-P-()-()	2,757.
FA-20H-K-()	2,869.

FA-20HCOV	683.
FA-28H-G-()-()	2,785.
FA-28H-P-()-()	3,398.
FA-28H-K-()	3,509.

FA-28HCOV	801.
FA-90H-G-()-()	3,899.
FA-90H-P-()-()	4,818.
FA-90H-K-()	5,347.

FA-90HCOV	1,030.
-----------	--------

Construction

Wood top finishes:
Teak (suffix K)

Maintenance:
See pages 28-29.

Frame:

Frame is aluminum extrusions with mitered corners and interior stainless steel connectors. Extruded aluminum legs screw into frame with stainless steel screws. Tops fit flush within the frame.

Glass Top:

$\frac{3}{8}$ " beveled glass top available in clear or acid etched.

Porcelain Top:

.08" thick steel plate with a porcelain enamel layer comprised of glass particles, baked to melt into a .002" smooth surface. Honey comb subtop comprised of metal or particle wood board provides additional support.

Teak:

1" natural teak.

Note:

Teak tops will patina over time if left outdoors and will turn a silvery grey color.





Glides:

Nylon adjustable glides.

Richard Schultz Topiary® Dining Tables

Designer(s):
Richard Schultz, 1996



description	w	d	h	weight	top
TOP-28 Topiary dining table base only	24"	24"	28"	45 lbs.	-
					
TH Umbrella support, powder coated, accepts 1 1/4" diameter umbrella shaft					
TI Umbrella weight				13 lbs.	
TG-30 Glass top	30"	30"		30 lbs.	tempered glass
					
TG-42 Glass top	42"	42"		66 lbs.	tempered glass
					
TG-56 Glass top	56"	56"		105 lbs.	tempered glass
					

Order Code

<i>Example:</i>	TOP-28-1
TOP-28	Dining table base
1	Forest Green base

Specify:

1. Pattern number
2. Base finish selection

Ordering Information

Finishes:
 Blue (suffix BLU)
 Chestnut (suffix N)
 Choice White (suffix 6)
 Daffodil Yellow (suffix 2)
 Dark Bronze (suffix 14)
 Forest Green (suffix 1)
 Green (suffix 007)
 Light Bronze (suffix 13)
 Lime Green (suffix LGR)
 Onyx (suffix O)
 Orange (suffix ORG)
 Plum (suffix PLM)
 Sky Blue (suffix 3)
 Terra Cotta (suffix 5)
 Warm Bronze (suffix 16)
 Warm Wood (suffix 12)
 Weatherable Silver (suffix S)
 White (suffix W)
 Yellow (suffix YEL)

Construction

Topiary frame:
 3/16" aluminum sheet stamped and formed. Stainless steel connectors and finished in highly durable weather resistant polyester powder coat paint.

Glass Top:
 3/8" beveled clear glass top.

pattern no.

TOP-28-()	\$2,775.
-------------------	----------

TH-()	696.
---------------	------

TI	295.
-----------	------





TG-30	724.
--------------	------

TG-42	1,114.
--------------	--------

TG-56	1,889.
--------------	--------

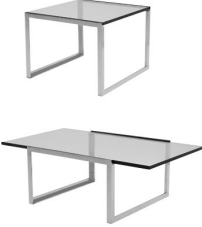
Shelton Mindel

SM Tables

	description	w	d	h
<p><i>Designer(s):</i> Peter Shelton and Lee Mindel, 2006</p> 	SM9 Shelton Mindel side table 	24"	24"	18"
	SM91 Shelton Mindel small coffee table 	42"	24"	14"
	SM92 Shelton Mindel large coffee table 	48"	30"	14"
	SM93 Shelton Mindel square coffee table 	40"	40"	14"

Order Code

<i>Example:</i>	SM93-2-S2
SM93	Shelton Mindel square coffee table
2	White
S2	Painted White Starphire

Note:
The SM tables are part of a collection. Please refer to SM side chair on page 274 and SM1 and SM2 lounge collection on pages 276 and 278.

Ordering Information

Specify:
1. Pattern number
2. Base option
3. Top option

Shipping:
Top and base of SM tables will ship in separate packages.

Glass top finishes:
Clear glass (suffix G2)
Painted White Starphire (suffix S2)

Slate top finish:
Natural black (suffix SN)

Base finishes:
White (suffix 2)
Stainless Steel (suffix S)

Maintenance:
See pages 27-28.

Note:
The SM Table Collection is Greenguard certified.

For weight information, please contact your KnollStudio representative.

pattern no.	white/ clear glass	white/ painted glass	white/ slate	stainless/ clear glass	stainless/ painted glass	stainless/ slate
SM9-(-)(-)	\$3,543.	\$3,846.	\$6,317.	\$3,906.	\$4,208.	\$6,677.
SM91-(-)(-)	3,564.	4,094.	7,344.	4,054.	4,586.	7,834.
SM92-(-)(-)	3,961.	4,620.	8,305.	4,305.	4,964.	8,649.
SM93-(-)(-)	6,470.	7,258.	9,315.	7,101.	7,967.	9,947.

Construction

Frame:

Constructed of seamless stainless steel, frame has continuous appearance. White bases are coated in a tough, abrasion-resistant Rilsan finish. Polished bases are stainless steel, hand buffed to a mirror finish. Tops rest on four transparent silicon spacers.

Top:





Three top options: $\frac{3}{4}$ " thick clear glass with a $\frac{1}{8}$ " wide bevel, top and edges have a slight green tint; $\frac{3}{4}$ " thick Starphire™ glass with a bevel edge, underside of glass is painted white; $\frac{3}{4}$ " thick natural cleft slate with beveled edge.

Glides:

Glides are included with the table base.

Daniel Stromborg

Round Tables

	description	w	d	h
<i>Designer(s):</i> Daniel Stromborg, 2012	DS02 Round table 	32"	32"	29"
<i>Award(s):</i> Best of NeoCon Silver Award 2012	DS04 Round table 	36"	36"	29"
	DS06 Round table 	42"	42"	29"

Order Code

<i>Example:</i>	DS02-118-WHT-YEL
DS02	32" Round table
118	Bright White laminate top
WHT	White leg finish
YEL	Yellow rail finish

Specify:

1. Pattern number
2. Top finish
3. Leg finish
4. Rail finish

Ordering Information

Leg paint finishes:
White (suffix WHT)
Dark Charcoal (suffix CHR)

Rail paint finishes:
White (suffix WHT)
Grey (suffix GRY)
Dark Charcoal (suffix CHR)
Yellow (suffix YEL)
Lime Green (suffix LGR)
Orange (suffix ORG)
Plum (suffix PLM)
Sky Blue (suffix SBL)
Blue (suffix BLU)

Top Finishes:

Laminate, outdoor:
Bright White (suffix O118)

Glass:
Clear Glass (suffix G2)

Natural Marble:
Cararra, honed (suffix GCO)

Engineered Stone:
Vetro Bianco (suffix VB)

Note:
All finishes and surfaces are suitable for outdoor use.

Maintenance:
See pages 28-29.

Construction

Frame:
Frames are constructed from extruded aluminum rails, which are connected using die-cast aluminum 'X' and 'Y' shaped castings. Structural steel legs join the table's extruded aluminum rails through a blind assembly, seamlessly tying the leg to the cope detailed rail. Stainless steel hardware and fasteners are used throughout the table's construction.

All painted parts are finished in ultra-durable outdoor polyester powder coat finish. Steel legs are pre-treated with a zinc-rich epoxy primer that provides a robust base of protection from the elements.

Tops are elevated off the table's base using cast aluminum (glass) or nylon spacers (laminate, marble, or engineered stone). All tops are secured to the base using threaded metal inserts and fasteners. For glass tops, the plated brushed aluminum spacer acts as a glass bolt and is attached to the glass using an ultra-strong adhesive.

pattern no.	laminate	glass (G2)	GCO	engineered stone (VB)
DS02-(-)(-)(-)	\$1,491.	\$1,850.	\$2,841.	\$3,020.
DS04-(-)(-)(-)	1,647.	2,143.	3,177.	3,388.
DS06-(-)(-)(-)	1,909.	2,638.	4,128.	4,347.

Outdoor Laminate:

White laminate faces with black phenolic core. Core is constructed of FSC certified craft paper and phenolic resin.

Glass:

1/2" thick clear tempered glass.

Marble:

Honed natural Cararra marble.

Note:

Marble is treated to resist stains with a topical sealer, which requires maintenance. Natural marbles will develop a rich patina when used outdoors.

Engineered Stone:



Polished, bright white surface is nonporous and more compact than most granites. Comprised of 93% fused quartz. It does not yellow or stain and is scratch resistant. Suitable for outdoors.

Glides:

Non-marking indoor/outdoor grey nylon glide protects the table and the floor. An adjustable height indoor glide kit is also included.

Daniel Stromborg

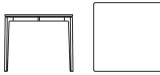
Square Tables

	description	w	d	h
<p><i>Designer(s):</i> Daniel Stromborg, 2012</p> <p><i>Award(s):</i> Best of NeoCon Silver Award 2012</p> 	<p>DS08 Square table</p> 	36"	36"	29"
	<p>DS10 Square table</p> 	42"	42"	29"
	<p>DS12 Square table</p> 	48"	48"	29"

Order Code

<i>Example:</i>	DS08-NGC-CHR-PLM
DS08	36" square table
NGC	Cararra marble top
CHR	Dark Charcoal leg finish
PLM	Plum rail finish

Specify:

1. Pattern number
2. Top finish
3. Leg finish
4. Rail finish

Ordering Information

Leg paint finishes:
White (suffix WHT)
Dark Charcoal (suffix CHR)

Rail paint finishes:
White (suffix WHT)
Grey (suffix GRY)
Dark Charcoal (suffix CHR)
Yellow (suffix YEL)
Lime Green (suffix LGR)
Orange (suffix ORG)
Plum (suffix PLM)
Sky Blue (suffix SBL)
Blue (suffix BLU)

Top Finishes:

Laminate, outdoor:
Bright White (suffix O118)

Glass:
Clear Glass (suffix G2)

Natural Marble:
Cararra, honed (suffix GCO)

Engineered Stone:
Vetro Bianco (suffix VB)

Note:
All finishes and surfaces are suitable for outdoor use.

Maintenance:
See pages 28-29.

Construction

Frame:
Frames are constructed from extruded aluminum rails, which are connected using die-cast aluminum 'X' and 'Y' shaped castings. Structural steel legs join the table's extruded aluminum rails through a blind assembly, seamlessly tying the leg to the cope detailed rail. Stainless steel hardware and fasteners are used throughout the table's construction.

All painted parts are finished in ultra-durable outdoor polyester powder coat finish. Steel legs are pre-treated with a zinc-rich epoxy primer that provides a robust base of protection from the elements.

Tops are elevated off the table's base using cast aluminum (glass) or nylon spacers (laminate, marble, or engineered stone). All tops are secured to the base using threaded metal inserts and fasteners. For glass tops, the plated brushed aluminum spacer acts as a glass bolt and is attached to the glass using an ultra-strong adhesive.

pattern no.	laminate	G2	GCO	engineered stone (VB)
DS08-(-)(-)(-)	\$1,685.	\$2,094.	\$3,228.	\$3,394.
DS10-(-)(-)(-)	1,957.	2,446.	3,616.	3,868.
DS12-(-)(-)(-)	2,264.	3,001.	4,051.	4,321.

Outdoor Laminate:

White laminate faces with black phenolic core. Core is constructed of FSC certified craft paper and phenolic resin.

Glass:

1/2" thick clear tempered glass.

Marble:

Honed natural Cararra marble.

Note:

Marble is treated to resist stains with a topical sealer, which requires maintenance. Natural marbles will develop a rich patina when used outdoors.

Engineered Stone:



Polished, bright white surface is nonporous and more compact than most granites. Comprised of 93% fused quartz. It does not yellow or stain and is scratch resistant. Suitable for outdoors.

Glides:

Non-marking indoor/outdoor grey nylon glide protects the table and the floor. An adjustable height indoor glide kit is also included.

Daniel Stromborg

Rectangular Tables

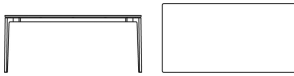
	description	w	d	h
<p><i>Designer(s):</i> Daniel Stromborg, 2012</p> <p><i>Award(s):</i> Best of NeoCon Silver Award 2012</p> 	<p>DS14 Rectangular table</p> 	60"	30"	29"
	<p>DS16 Rectangular table</p> 	72"	36"	29"

Order Code

Example: **DS14-G2-WHT-BLU**

DS14	60" x 30" rectangular table
G2	Clear glass top
WHT	White leg finish
BLU	Blue rail finish

Specify:

1. Pattern number
2. Top finish
3. Leg finish
4. Rail finish

Ordering Information

Leg paint finishes:
White (suffix WHT)
Dark Charcoal (suffix CHR)

Rail paint finishes:
White (suffix WHT)
Grey (suffix GRY)
Dark Charcoal (suffix CHR)
Yellow (suffix YEL)
Lime Green (suffix LGR)
Orange (suffix ORG)
Plum (suffix PLM)
Sky Blue (suffix SBL)
Blue (suffix BLU)

Top Finishes:

Laminate, outdoor:
Bright White (suffix O118)

Glass:
Clear Glass (suffix G2)

Natural Marble:
Cararra, honed (suffix GCO)

Engineered Stone:
Vetro Bianco (suffix VB)

Note:
All finishes and surfaces are suitable for outdoor use.

Maintenance:
See pages 28-29.

Construction

Frame:
Frames are constructed from extruded aluminum rails, which are connected using die-cast aluminum 'X' and 'Y' shaped castings. Structural steel legs join the table's extruded aluminum rails through a blind assembly, seamlessly tying the leg to the cope detailed rail. Stainless steel hardware and fasteners are used throughout the table's construction.

All painted parts are finished in ultra-durable outdoor polyester powder coat finish. Steel legs are pre-treated with a zinc-rich epoxy primer that provides a robust base of protection from the elements.

Tops are elevated off the table's base using cast aluminum (glass) or nylon spacers (laminate, marble, or engineered stone). All tops are secured to the base using threaded metal inserts and fasteners. For glass tops, the plated brushed aluminum spacer acts as a glass bolt and is attached to the glass using an ultra-strong adhesive.

pattern no.	laminate	G2	GCO	engineered stone (VB)
DS14-(-)-(-)	\$2,032.	\$2,673.	\$3,734.	\$3,963.
DS16-(-)-(-)	2,477.	3,380.	4,457.	4,695.

Outdoor Laminate:

White laminate faces with black phenolic core. Core is constructed of FSC certified craft paper and phenolic resin.

Glass:

1/2" thick clear tempered glass.

Marble:

Honed natural Cararra marble.

Note:

Marble is treated to resist stains with a topical sealer, which requires maintenance. Natural marbles will develop a rich patina when used outdoors.

Engineered Stone:

Polished, bright white surface is nonporous and more compact than most granites. Comprised of 93% fused quartz. It does not yellow or stain and is scratch resistant. Suitable for outdoors.

Glides:

Non-marking indoor/outdoor grey nylon glide protects the table and the floor. An adjustable height indoor glide kit is also included.

Vignelli Associates PaperClip™ Cafe Tables

Designer(s):
Vignelli Design, 1994

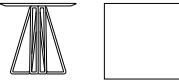
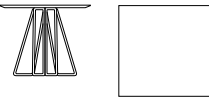
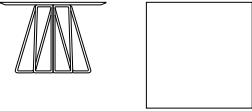
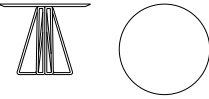
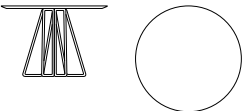
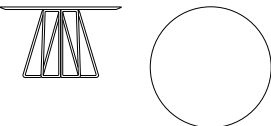

description	w	d	h	weight	top
49TS-30 Square table, small 	30"	30"	28 1/8"	37 lbs.	Laminate
	30"	30"	28 1/8"	51 lbs.	Clear glass
	30"	30"	28 1/8"	51 lbs.	White glass
	30"	30"	28 1/8"	72 lbs.	Slate
49TS-36 Square table, medium 	36"	36"	28 1/8"	55 lbs.	Laminate
	36"	36"	28 1/8"	75 lbs.	Clear glass
	36"	36"	28 1/8"	75 lbs.	White glass
	36"	36"	28 1/8"	105 lbs.	Slate
49TS-42 Square table, large 	42"	42"	28 1/8"	75 lbs.	Laminate
	42"	42"	28 1/8"	103 lbs.	Clear glass
	42"	42"	28 1/8"	103 lbs.	White glass
	42"	42"	28 1/8"	144 lbs.	Slate
49TR-36 Round table, small 	36"		28 1/8"	41 lbs.	Laminate
	36"		28 1/8"	57 lbs.	Clear glass
	36"		28 1/8"	57 lbs.	White glass
	36"		28 1/8"	80 lbs.	Slate
49TR-42 Round table, medium 	42"		28 1/8"	58 lbs.	Laminate
	42"		28 1/8"	80 lbs.	Clear glass
	42"		28 1/8"	80 lbs.	White glass
	42"		28 1/8"	112 lbs.	Slate
49TR-48 Round table, large 	48"		28 1/8"	76 lbs.	Laminate
	48"		28 1/8"	106 lbs.	Clear glass
	48"		28 1/8"	106 lbs.	White glass
	48"		28 1/8"	147 lbs.	Slate

Order Code

<i>Example:</i>	49TS-30-SN-1
49TS-30	PaperClip table, square, 30"
SN	Natural Black slate
1	Black

The Vignelli PaperClip Tables are part of a collection. Please refer to Vignelli Handkerchief Chairs on page 298.

Specify:

1. Pattern number
2. Top finish selection
3. Urethane edge detail (laminate tops only)
4. Leg finish selection

Ordering Information

Laminate top finishes:
Bright White (suffix 118)
Light Grey (suffix L)
Fog (suffix 128)
Jet Black (suffix 111)

Urethane edge finishes:
Light Grey (suffix LG)
Medium Grey (suffix MG)
Black (suffix BL)

Glass top finishes:
Clear (suffix G2)
White (suffix G3)

Slate top finish:
Natural Black (suffix SN)

Outdoor Powder Coat Finish:
Black (suffix 1)

Chrome base finish:
Polished Chrome (suffix C)

Maintenance:
See pages 28-29.

Note:
The PaperClip Table is Greenguard certified.

pattern no.	Painted/ black base	Pol. chrome base
49TS-30-()-()-()	\$1,984.	\$2,205.
49TS-30-G2-()	2,205.	2,427.
49TS-30-G3-()	2,426.	2,647.
49TS-30-SN-()	5,077.	5,297.
<hr/>		
49TS-36-()-()-()	2,205.	2,536.
49TS-36-G2-()	2,650.	2,980.
49TS-36-G3-()	2,933.	3,263.
49TS-36-SN-()	6,028.	6,357.
<hr/>		
49TS-42-()-()-()	2,426.	2,871.
49TS-42-G2-()	3,091.	3,535.
49TS-42-G3-()	3,423.	3,867.
49TS-42-SN-()	7,429.	7,876.
<hr/>		
49TR-36-()-()-()	1,984.	2,205.
49TR-36-G2-()	2,871.	3,092.
49TR-36-G3-()	3,091.	3,311.
49TR-36-SN-()	6,196.	6,416.
<hr/>		
49TR-42-()-()-()	2,205.	2,536.
49TR-42-G2-()	3,203.	3,533.
49TR-42-G3-()	3,491.	3,819.
49TR-42-SN-()	7,763.	8,093.
<hr/>		
49TR-48-()-()-()	2,426.	2,871.
49TR-48-G2-()	3,644.	4,089.
49TR-48-G3-()	4,087.	4,531.
49TR-48-SN-()	8,887.	9,331.

Construction

Top:
Three top options: 1" thick laminate top with molded urethane beveled edge; 1/2" thick clear tempered glass with polished pencil edge; and 3/4" thick natural cleft slate with beveled edge.

Base:
7/16" diameter cold rolled steel rod with fused polyester, outdoor powder coat and chrome-plated finishes.

Glides:
Plastic.

Outdoor use:
With proper preventative maintenance and limited exposure to the elements, the PaperClip cafe table is appropriate for outdoor environments. Specify outdoor powder coat black (suffix 1) base finish and clear glass (suffix G2) or slate (suffix SN) tops.

Shipping:
All tables shipped knocked-down. Base and top assembly required.

Laminate/slate edge detail:

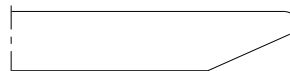

Glass edge detail:

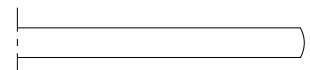

<i>pattern no.</i>	<i>page</i>	<i>pattern no.</i>	<i>page</i>	<i>pattern no.</i>	<i>page</i>	<i>pattern no.</i>	<i>page</i>
1050C	212	173TR-F2	374	1966-255	264	1966-55COV	400
1050C-1	212	174TO	378, 386	1966-255COV	264	1966-55-F	400
1050C-2	212	174TO-F2	378	1966-25COV	264	1966-55-K	400
1050C-3	212	175TO	378	1966-25P	264	1966-55-P	400
1051C	210	175TO-F2	378	1966-26BCOV	394	1966-60BCOV	394
1051C-S	206	176TR	374	1966-26B-F	394	1966-60B-F	394
1051C-ST	206	176TR-F2	374	1966-26B-G	394	1966-60B-G	394
1052C	210	1966-18LCOV	396	1966-26B-K	394	1966-60B-K	394
1052C-S	208	1966-18L-F	396	1966-26B-P	394	1966-60B-P	394
1053C	210	1966-18L-G	396	1966-26CCOV	392	1966-60CCOV	392
1053C-S	208	1966-18L-K	396	1966-26C-F	392	1966-60C-F	392
1059C	210	1966-18L-P	396	1966-26C-G	392	1966-60C-G	392
1059C-S	208	1966-19LCOV	396	1966-26C-K	392	1966-60C-K	392
108	322	1966-19L-F	396	1966-26C-P	392	1966-60C-P	392
108-KC-111	322	1966-19L-G	396	1966-26HCOV	390	1966-60HCOV	390
1205-CO-S1	128	1966-19L-K	396	1966-26H-F	390	1966-60H-F	390
1205-CO-S2	128	1966-19L-P	396	1966-26H-G	390	1966-60H-G	390
1205-CO-S3	128	1966-20BCOV	394	1966-26H-K	390	1966-60H-K	390
1205-C-S1	128	1966-20B-F	394	1966-26H-P	390	1966-60H-P	390
1205-C-S2	128	1966-20B-G	394	1966-26LCOV	396	1966-60LCOV	396
1205-C-S3	128	1966-20B-K	394	1966-26L-F	396	1966-60L-F	396
1250BUTTON	218	1966-20B-P	394	1966-26L-G	396	1966-60L-G	396
12A	218	1966-20CCOV	392	1966-26L-K	396	1966-60L-K	396
12C	218	1966-20C-F	392	1966-26L-P	396	1966-60L-P	396
150AS	242	1966-20C-G	392	1966-28BCOV	394	1966-90HCOV	390
150AX	242	1966-20C-K	392	1966-28B-F	394	1966-90H-F	390
150K	242	1966-20C-P	392	1966-28B-G	394	1966-90H-G	390
151CS	242	1966-20HCOV	390	1966-28B-K	394	1966-90H-K	390
151CX	242	1966-20H-F	390	1966-28B-P	394	1966-90H-P	390
151K	242	1966-20H-G	390	1966-28CCOV	392	1966-90LCOV	398
153YS	242	1966-20H-K	390	1966-28C-F	392	1966-90L-F	398
160TR	380	1966-20H-P	390	1966-28C-G	392	1966-90L-G	398
160TR-F2	380	1966-20LCOV	396	1966-28C-K	392	1966-90L-K	398
161TO	384	1966-20L-F	396	1966-28C-P	392	1966-90L-P	398
161TO-F2	384	1966-20L-G	396	1966-28HCOV	390	2160-C	100
162TO	384	1966-20L-K	396	1966-28H-F	390	2160R	104
162TO-F2	384	1966-20L-P	396	1966-28H-G	390	2160RS	104
162TR	380	1966-24BCOV	394	1966-28H-K	390	2160S-C	100
162TR-F2	380	1966-24B-F	394	1966-28H-P	390	2161-C	102
163TR	380	1966-24B-G	394	1966-28LCOV	398	2161P	102
163TR-F2	380	1966-24B-K	394	1966-28L-F	398	2161S-C	102
164TR	374, 376	1966-24B-P	394	1966-28L-G	398	2162P	106
164TR-F2	374	1966-24CCOV	392	1966-28L-K	398	2162R	106
165TR	376	1966-24C-F	392	1966-28L-P	398	2162RS	106
165TR-F2	376	1966-24C-G	392	1966-355	264	2163-C	102
169TR	380, 382, 386	1966-24C-K	392	1966-355COV	264	2163R	106
169TR-F2	380	1966-24C-P	392	1966-41	266	2163RS	106
1705L-N	216	1966-24HCOV	390	1966-41COV	266	2163S-C	102
1709Y-N	216	1966-24H-F	390	1966-41P	266	2165	108
1715L-BRM	214	1966-24H-G	390	1966-42	266	23A	138
1715L-GLD	214	1966-24H-K	390	1966-42COV	266	23AK-N	138
1715L-N	214	1966-24H-P	390	1966-42P	266	23C	138
1719Y-BRM	214	1966-24LCOV	396	1966-45H	260	23CH	138
1719Y-GLD	214	1966-24L-F	396	1966-45HCOV	260	23CK-N	138
1719Y-N	214	1966-24L-G	396	1966-45P	260, 262	23DOLLY	138
1725A-BRM	214	1966-24L-K	396	1966-46B	262	23GA	138
1725A-GLD	214	1966-24L-P	396	1966-46BCOV	262	23TR24	364
1725A-N	214	1966-25	264	1966-46C	262	23TR27	364
172TR	374	1966-250	264	1966-46CCOV	262	23TR36	364
172TR-F2	374	1966-250COV	264	1966-46H	260	23TR42	364
173TR	374, 386	1966-250P	264	1966-46HCOV	260	23TRH24	364

<i>pattern no.</i>	<i>page</i>	<i>pattern no.</i>	<i>page</i>	<i>pattern no.</i>	<i>page</i>	<i>pattern no.</i>	<i>page</i>
23TRH27	364	27DOLLY	158, 160	420CT-K	48	48R	224
23TS24	364	29C	204	420CT-KP	48	4901	298
23TS30	364	29K	204	420CT-U	48	4901K-N	298
23TSH24	364	29TR-23-DE	360	420F	46, 48	4901K-S	298
23TSH27	364	29TR-23-LM	360	420K	46, 48	4902	300
241LS	188	29TR-27-DE	360	420KP	46, 48	4902K-N	300
242LS	188	29TR-27-LM	360	420P	46, 48	4902K-S	300
245A-C	182	29TR-35-DE	362	421F	54, 56	49100D	298, 300
245A-S	182	29TR-35-LM	362	421FS	54	49TR-36	414
245AT-C	182	29TR-43-DE	362	421K	54, 56	49TR-36-G2	414
245AT-S	182	29TR-43-LM	362	421KS	54	49TR-36-G3	414
247LS	188	29TR-H-23-DE	360	421L	54	49TR-36-SN	414
2480D	324	29TR-H23-LM	360	421LCO-K	54	49TR-42	414
2481D	324	29TS-27-DE	360	421LCO-U	54	49TR-42-G2	414
2482T	326	29TS-27-LM	360	421L-GLD-K	54	49TR-42-G3	414
2485D	328	29TS-35-DE	362	421LS-C-K	54	49TR-42-SN	414
248LS	188	29TS-35-LM	362	421LS-C-U	54	49TR-48	414
250LC	192	3	244, 248	421LT-K	56	49TR-48-G2	414
250LC-S	192	30C2-A	96	421LT-U	56	49TR-48-G3	414
250LS	192	30C3-A	96	422F	54	49TR-48-SN	414
2510T	334	30C-A	96	422L	54	49TS-30	414
2510T()	334	311-F1	358	423F	58	49TS-30-G2	414
2511T	334	311-F2	358	423L	58	49TS-30-G3	414
2511T()	334	312-F1	358	424F	58	49TS-30-SN	414
2515T	336	312-F2	358	424Y	58	49TS-36	414
2515T()	336	3710T	366	427C	52	49TS-36-G2	414
2517T	336	3712T	368	427C-CO-K	52	49TS-36-G3	414
2517T()	336	3714T	368	427C-CO-KP	52	49TS-36-SN	414
251YC	192	3716T	366	427C-CO-U	52	49TS-42	414
251YC-L80	192	37A	226	427F	52	49TS-42-G2	414
251YC-S	192	37A-U	230	427K	52	49TS-42-G3	414
251YS	192	37C	226	427KP	52	49TS-42-SN	414
252	346	37C-U	232	427P	52	4-C-LG-N	94
252C	346	37R	226	428C	50	4-C-LG-S	94
252C-SFG	346	37R-T	226	428C-CO-K	50	4-C-SD-N	92
252-SFG	346	38A	110	428C-CO-KP	50	4-C-SD-S	92
2530Y2C	128	38A-KC or		428C-CO-U	50	4DOLLY	92
2530Y3C	128	38AW-KC	110	428F	50	4GA	92
2541M	330	38AW-U	110	428K	50	4LGSEAT	94
2542M	330	38AW-U-KC	110	428KP	50	4SDSEAT	92
2543M	332	38C	112	428P	50	50A-5-B	86
2544M	332	38C-KC or		429F	60	50A-5-BE	86
2545M	330	38CW-KC	112	429K	60	50A-7	86
2546M	330	38CW-U	114	429L	60	50AR-5-B	86
2547M	332	38CW-U-KC	114	44A	228	50AR-5-BE	86
2548M	332	38R	114	44AU	234	50AR-7	86
2549M	332	400K	62	44R	228	50C-1-B	88
255A-C	184	400Y	62	46A	164	50C-1-BE	88
255A-S	184	410K	62	46A-U	164	50C-2	88
255C-C	184	410Y	62	46C	164	50CR-1-B	88
255C-S	184	410Y-SK	62	46C-U	164	50CR-1-BE	88
256AKIT-L	190	41A	116	47TR15	352	50CR-2	88
256AS-L	190	41A-KC or		47TR19	354	50CS	296
256CKIT-L	190	41AW-KC	116	47TR22	354	50KIT	296
256CS-L	190	41AW-U	116	47TR24	352	50KIT-L	296
256LACE-L	190	41AW-U-KC	116	47TR26	352	50L	90
257C	186	41C	118	47TR30	352	50LACE	296
258LS	192	41C-KC or		47TR50	352	50T1	310
259TS-G	346	41CW-KC	118	47TR72	352	50T2	310
27A	160	41CW-U	118	47TS15	350	53D1	294
27AGA	160	41CW-U-KC	118	47TS20	350	53D2	294
27C	158	41R	116, 118	47TS31	350	53D3	294
27CGA	158	420C	46	47TS48	350	53S1	294
27CM	162	420C-CO-K	46	47TS64	350	53S2	294
27CS	162	420C-CO-KP	46	48A	224	53S3	294
		420C-CO-U	46				

<i>pattern no.</i>	<i>page</i>	<i>pattern no.</i>	<i>page</i>	<i>pattern no.</i>	<i>page</i>	<i>pattern no.</i>	<i>page</i>
58A	98	68R	154	91C-GC	120	AAR5 cushions	80
58A-R	98	69	154	91C-GC-K	120	AAR5S	80
58C	98	69R	154	91K	120	AAR6	80
58C-R	98	70L	252	92C-GC	120	AAR6 cushions	80
59Dolly	164	70LM	256	92C-GC-K	120	AAR6S	80
614TS-KC-KC	370	70LS	258	92K	120	AAR7	80
614TS-KE-D	370	71A	244	93A-GC	122	AAR7 cushions	80
614TS-LWT-LWT	370	71A-T5G	244	93A-GC-K	122	AAR7S	80
618TR-KC-KC	370	71A-W	246	93K	122	AAR8	74
618TR-KE-D	370	72C	248, 250	94K	122	AAR8 cushions	74
618TR-LWT-LWT	370	72C-T5G-H	248	94L-GC	122	AAR8S	74
6242	314	72C-W	250	94L-GC-K	122	AAR9	74
6248	314	73	156	94LY-GC	122	AAR9 cushions	74
6254	314	73L	254	94LY-GC-K	122	AAR9S	74
6260	316	73R	156	94YK	122	BO10C-AE	44
6272	316	74Y	252	95T-36-G2-GC	320	BO10C-AP	44
6348	312	74YM	256	95T-36-W-GC	320	BO10CO	44
6354	312	751	194	95T-40-G2-GC	320	BO10CO-K	44
6360	312	751LT	194	95T-40-W-GC	320	BO11C	44
642TR-KC-KC	370	752	194	AAC1	64	BO11C-AE	44
642TR-KE-D	370	752LT	194	AAC1 cushions	64	BO11C-AP	44
642TR-LWT-LWT	370	753	196	AAC1S	64	BO11C-K	44
643TA-KC-KC	370	753LT	196	AAC2	66	BO15L	38
643TA-KE-D	370	754	196	AAC2 cushions	66	BO15R	38
643TA-LWT-LWT	370	754LT	196	AAC2S	66	BO2	38
643TAS-HB-HL	372	755	198	AAC3	66	BO21T-AE	308
6472	318	755LT	198	AAC3 cushions	66	BO21T-K	308
6484	318	756	198	AAC3S	66	BO3	38
6496	318	756LT	198	AAC4	64	BO4	38
654LA	240	759	348	AAC4 cushions	64	BO5L	38
654LC	240	760	348	AAC4S	64	BO5R	38
654L-KIT	240	78	180	AAC5	68	BO6	38
657	220	78CH	180	AAC5 cushions	68	BO7	38
666C	236	78CM	180	AAC5S	68	BO8P	42
666C-KIT	236	790	222	AAC6	68	BO9P	42
666CS-HB	238	80D	306	AAC6 cushions	68	BOC1	40
666CS-KIT	238	83ANCHOR	150	AAC6S	68	BOC2	40
666CS-WB-HB	238	83Y-K	146	AAC7	68	C	312, 314, 316, 318
666CS-WB-KIT	238	83YM	146	AAC7 cushions	68	CB1-C	82
666C-WB	236	83YMW	146	AAC7S	68	CB1-L	82
666C-WB-KIT	236	84Y-K	148	AAR1	70	CB2-C	82
667Y	236	84YM	148	AAR1 cushions	70	CB2-L	82
667Y-KIT	236	84YMW	148	AAR10	76	CB3	82
667YS-HB	238	85T32M	148	AAR10 cushions	76	CBP1	84
667YS-KIT	238	87A	166	AAR10S	76	CBP2	84
66S1-M	282	87A-K-N	166	AAR11	76	CX	312, 314, 316, 318
66S1-Y	282	87A-K-S	168	AAR11 cushions	76	DS02	408
66S2-M	284	87AS	178	AAR11S	76	DS04	408
66S2-Y	284	87C	170	AAR12L	78	DS06	408
66S3-M	286	87CH	178	AAR12L cushions	78	DS08	410
66S3-Y	286	87C-K-N	170	AAR12LS	78	DS10	410
66SC-N	290	87C-K-S	172	AAR12R	78	DS12	410
66SC-W	290	87CM	178	AAR12R cushions	78	DS14	412
66SH-A	288	87CS	178	AAR12RS	78	DS16	412
66SH-B	288	87CSB	174	AAR1S	70	FA-20HCOV	402
66SH-C	288	87CSB-K-N	174	AAR2	72	FA-20H-G	402
66SH-D	288	87CSB-K-S	176	AAR2 cushions	72	FA-20H-K	402
66SH-E	288	87Dolly	168, 172, 176	AAR2S	72	FA-20H-P	402
66SH-F	288	87DOLLY	180	AAR3	72	FA-26HCOV	402
66SH-G	290	87-F1	358	AAR3 cushions	72	FA-26H-G	402
67	152	87-F2	358	AAR3S	72	FA-26H-K	402
67R	152	87GA	168, 172	AAR4	70	FA-26H-P	402
67S	152	87TABLET	168, 172	AAR4 cushions	70	FA-28HCOV	402
68	154	91A-GC	120	AAR4S	70	FA-28H-G	402
68C	156	91A-GC-K	120	AAR5	80	FA-28H-K	402

<i>pattern no.</i>	<i>page</i>	<i>pattern no.</i>	<i>page</i>	<i>pattern no.</i>	<i>page</i>
FA-28H-P	402	OAC1	202	TOP-28	404
FA-45COV	272	P	182, 184	TOP-45	270
FA-45P	272	P320COV	388	TOP-455	270
FA-45TB	272	P320-K	388	TOP-455COV	270
FA-60HCOV	402	P320-W	388	TOP-45COV	270
FA-60H-G	402	P321COV	388	TR	158
FA-60H-K	402	P321-K	388	TSC	270
FA-60H-P	402	P321-W	388	TSCOV	270
FA-90HCOV	402	P322COV	388	TSCOV4	270
FA-90H-G	402	P322-K	388	TSOP	270
FA-90H-K	402	P322-W	388	upchg, welt	124, 126, 194, 196, 198, 244, 246
FA-90H-P	402	R	218, 244, 248	upchg,	
G	182, 184, 298	RL1	340	cushions	100, 102, 104, 106, 278
G [4902]	300	RL11-17	344	upchg,	
GL	312, 314, 316, 318	RL1-118	340	cushionsS	280
H	208	RL11-22	344	upchg,	
JL1-P	124	RL2	340	cushionsSO	280
JL1-PLT	124	RL2-118	340	WC1T	302
JL1-W	126	RL3-SFG-MTC	340	WC2T	302
JL1-WLT	126	RL5L-54	342	WL21F	34
JL2-P	124	RL5L-54-118	342	WL21S	34
JL2-PLT	124	RL5L-60	342	WL23	34
JL2-W	126	RL5L-60-118	342	WL25	304
JL2-WLT	126	RL5M-42	342	WS1CA	36
JL3-P	124	RL5M-42-118	342	WS1CA-CC	36
JL3-PLT	124	RL5M-48	342	WS1CA-NCU	36
JL3-W	126	RL5M-48-118	342	WS1CA-NO	36
JL3-WLT	126	SM1-1	276	WS2CN	36
KL1	130	SM1-2	276		
KL10	134	SM1-3	276		
KL11	134	SM2-1	278		
KL2	130	SM2-2	280		
KL3	130	SM2-3	280		
KL4	130	SM2S-1	278		
KL5	132	SM2S-2	280		
KL6	132	SM2S-3	280		
KL7	132	SM8A	274		
KL8	134	SM8A-U	274		
KL9	134	SM8R	274		
KSP1	136	SM9	406		
KSP1S	136	SM91	406		
KSP2	136	SM92	406		
KSP2S	136	SM93	406		
KSP3	136	SWELL-20P	268		
KSP3S	136	SWELL-31	268		
L	164	SWELL-31COV	268		
MK01A	140	SWELL-31P	268		
MK01AU	140	SWELL-32	268		
MK01C	142	SWELL-32COV	268		
MK01CU	142	SWELL-33	268		
MK01R	140, 142	SWELL-33COV	268		
MK01RCN	140, 142	T	226		
MK02A	144	TBP	270		
MK02C	144	TDCP	270		
MK02R	144	TC-30	404		
MK02RCN	144	TC-42	404		
MK11	338	TC-56	404		
MK12	338	TH	404		
MK13	338	TI	404		
MK14	338	TLCP	270		
MK15	338	TOP-15	270		
MK16	338	TOP-25	270		
N10	356	TOP-250	270		
N19-AW	200	TOP-250COV	270		
N20-DF	356	TOP-25COV	270		

Selling Policy

	<p>This Selling Policy supercedes all previous selling policies. Prices, discounts and product offerings are subject to change without notice.</p>
Terms & Conditions of Sales	<p>Sales by Knoll, Inc. or Knoll North America Corp. ("Seller") of Knoll Product Lines (hereinafter "Products") within the United States and Canada are made only on the terms which are contained in this Selling Policy. Seller hereby gives notice of its objection to any different or additional terms and conditions. This sale is expressly conditional upon Purchaser's assent to the terms and conditions set forth below. Additional terms and conditions may apply to KnollStudio and KnollTextiles orders. These terms and conditions may be modified or supplemented only by a written document signed by an authorized representative of Seller. These terms and conditions supercede any prior and/or contemporaneous agreements or correspondence between Purchaser and Seller. Written quotations expire thirty (30) days from the date of issuance and can be withdrawn by written notice anytime during that period. Where Purchaser and Seller have entered into the Knoll Electronic Terms and Conditions, all orders, acknowledgements, invoices and other business communications placed or transmitted in accordance with the Knoll Electronic Terms and Conditions shall be deemed to be in writing and signed and shall be valid for all purposes as if they were originated and maintained in documentary form.</p>
Ordering Information	<p>All orders must be in writing. The product pattern number(s) contained on Seller's order acknowledgement shall be the final expression of the order.</p>
Order Confirmation	<p>A purchase order is not binding on Seller until Purchaser has received Seller's order confirmation or acknowledgment.</p>
Pricing Policies	<p>List prices are subject to change without notice.</p> <p>List prices shall be those prices in effect on the date of receipt of a complete purchase order unless shipment is requested more than ninety (90) days after order entry in which case prices in effect on the date of shipment apply. List prices include specified freight costs. Unless specified in writing by Seller, no other charges are included in Seller's list prices.</p>
Taxes	<p>All sales, use, excise and other taxes applicable to the sale of the Products shall be paid by Purchaser. If Purchaser claims an exemption from any tax, Purchaser shall submit to Seller the appropriate exemption certificates.</p>
Terms of Payment	<p>Payment for one hundred percent (100%) of the net order amount is due within thirty (30) days of the date of invoice, which is generally issued upon shipment. In case of any discrepancies, such as shortages, and Seller is notified in writing within ten (10) days of receipt of Product, only that portion may be deducted and the balance paid. For orders greater than \$100,000 net, a fifty percent (50%) deposit is due at the time of order placement, with the remainder due within thirty (30) days of the date of invoice.</p> <p>KnollStudio orders less than \$2,000 require payment for one hundred percent (100%) of the net order amount (including any applicable sales tax and charges for inside delivery, special packaging, etc.), due at time of order placement. For KnollStudio orders greater than \$2,000, a one-half (50%) deposit is due at time of order placement with the remainder (including any applicable sales tax and charges for inside delivery, special packaging, etc.) due prior to shipment.</p> <p>If, in the judgment of Seller, Purchaser's financial condition does not justify the terms of the payment, Seller may require full or partial payment in advance.</p> <p>Past due accounts shall be charged one and one-half percent (1.5%) per month, or the highest rate permitted by law, whichever is less, and will be added to the outstanding balance. In the event Purchaser defaults on payment, Purchaser shall be liable for all collection costs, including reasonable attorney's fees and costs.</p>
Changes and Cancellation	<p>Purchase orders may not be changed or cancelled, in whole or in part, without prior written consent of Seller. Changes may effect delivery dates. Expenses incurred because of changes shall be charged to Purchaser. In the event of cancellations, Purchaser will be liable for reasonable cancellation charges established by Seller. Orders for special Product, orders including "COM" (hereinafter defined) material and orders pursuant to expedited delivery programs, may not be canceled.</p>
Freight Prepaid	<p>Freight is prepaid and included in the price of all Products, except KnollTextiles, within the 48 contiguous United States for orders placed with Knoll, Inc. and within Canada, excluding the Yukon, Northwest Territories, Nunavut and Newfoundland for orders placed with Knoll North America Corp. Packing is tested for rigorous motion and transportation but is not guaranteed to protect furniture from all conditions. If special packaging is required for any reason, please consult with your sales representative or dealer. Seller shall select the method of shipment and routing. Freight for all KnollTextiles orders is prepaid and added to the invoice.</p>
Delivery/Freight Charges	<p>Shipments outside the contiguous 48 United States and Canada shall be shipped F.O.B. Origin.</p> <p>For shipments outside the contiguous United States and Canada, Purchaser is responsible for the cost of freight from point of embarkation, including any handling and transportation charges incidental to loading at the point of departure and unloading at the final destination.</p> <p>Conditions beyond the control of Seller, including weather, available facilities and traffic conditions, may affect exact time of delivery. Seller shall not be responsible for specific carrier delivery date or time unless it has made a specific delivery commitment, in writing.</p> <p>Nonstandard methods of shipment and/or additional services are available upon request. Purchaser will be billed for the differential cost of any special services in excess of standard surface carrier freight costs. Premium charges, at Purchaser's request, will be added for airfreight, exclusive use of vehicle and extra, export or special packaging. Accessorial charges will be added for inside delivery, extra labor, reassignment and redelivery.</p> <p>Partial shipments may be made and invoiced by Seller.</p>
Claims	<p>All shipments for Knoll Products within the contiguous United States and Canada are F.O.B. Origin. All risk of loss passes to Purchaser at time of delivery to carrier. Purchaser shall inspect all Products upon receipt and notify Seller within ten (10) working days after receipt of any damage or defects which are, or should be, apparent from an inspection of the Product and its packaging. Failure of Purchaser to notify Seller during the ten (10) working day period shall constitute acceptance of the Products and waiver of any apparent defects, errors or shortages. For all claims relating to Product damaged in transit or for any other claims relating to or arising out of the transportation of the Product, Purchaser must seek recovery from the carrier and Seller has no liability to Purchaser for such claims. Seller may, upon request, assist Purchaser with filing of such claims with the carrier, but Seller will not be liable for any of these transportation related claims.</p>
Seller's Security Interest	<p>Until Seller receives the full payment for the Product, Seller shall have a security interest in the Product. Purchaser agrees to perform all acts, including but not limited to the execution and filing of documentation, which may be necessary to perfect and assure the security interest of Seller.</p>
Returns	<p>The return of Products without a written authorization by Seller shall not be accepted. To receive authorization for Product return, please call Customer Service. All Products that are returned pursuant to a valid authorization shall be subject to a twenty-five percent (25%) of list restocking charge. Products not currently offered for sale by Seller (including COM) shall not be authorized for return. All returned Products must be unused, in original condition and in the original Seller packing cartons. No refund or credit shall be given for damaged Products.</p>
Held Orders/Storage	<p>If Purchaser requests that an order be held or delayed, prices and terms and conditions in effect at the time of shipment shall apply. If Purchaser requests a delay after the time when Seller can defer production, Purchaser will be invoiced for the Product, payable in accordance with standard terms, when the order is ready for shipment. Seller may transfer the Product to storage, in which case all expenses incurred in connection with storage, including demurrage, preparation for storage, storage charges and handling shall be payable by Purchaser upon submission of invoices by Seller. Risk of loss to the Product shall pass to the Purchaser upon delivery of the Product into storage.</p>

Selling Policy

Customer's Own Material	<p>A Purchaser who requests a fabric or other surface material not standard to Seller's line of Products ("COM") must submit samples of the requested material to Seller prior to entry of a purchaser order. Seller shall determine if the material is suitable to its manufacturing processes and meets any requirements of Underwriters Laboratories. If the COM is acceptable, Seller will then establish a price for using the COM or the Product in question. For a description of the procedures for submitting samples and testing, contact customer resources or your sales representative. Seller shall have no responsibility for the appearance, condition, performance, durability, colorfastness or any other physical attribute of the COM. Purchaser shall indemnify and hold Seller harmless for any damages, injuries or losses arising out of or related to use of the COM on the Product.</p>
Warranty	<p>Seller warrants to the original Purchaser only that the Products Seller manufactures and sells to Purchaser are free of defects in workmanship and materials, during the applicable warranty period set forth below.</p> <p>Warranty period set forth below is for 24-hour, 7 days a week, multi shift use (includes parts and labor to repair).</p> <p>Should any failure to conform with this limited warranty appear to a Product listed below during the applicable warranty period from the date of shipment, Seller shall, upon prompt written notice, repair or replace, at its option and costs, the affected part or parts.</p> <p><i>Product and Period of Warranty</i></p> <p><i>Lifetime: Antenna Workspaces, AutoStrada, Calibre, Crinion Open Table, Currents, Dividends Horizon, Morrison, Reff Profiles laminate, Series 2 Storage, Template and other non-wood components (except cascade edge worksurfaces, operational parts, controls, electrical, Lighting, Series 2 Veneer Front Storage, special or custom products, see below)</i></p> <p><i>12 Years: Chadwick, Essentials Work Chairs, Generation by Knoll, Life, Moment, MultiGeneration by Knoll, ReGeneration by Knoll, Remix, and Toboggan seating (except seating upholstery, textiles, leathers and finishes, see below).</i></p> <p><i>10 Years: Anchor Storage except digital keypad lock, Antenna Workspaces, AutoStrada, Crinion Open Table, Dividends Horizon, Dividends Horizon Satellite Surfaces, Reff Profiles, Template wood components, Series 2 Veneer Front Storage, cascade edge worksurfaces, Wood Casegoods (The Graham Collection) (except wood casegoods upholstered surfaces, see below), Reuter overheads, Reuter vertical storage, KnollExtra Sapper Monitor Arm Collection, Sapper XYZ Monitor Arm, Adjustable keyboard mechanisms and platforms, Communication Boards (except fabric board textiles, see below), Smokador collection (except leathers, see below), and Orchestra Universal Systems Accessories, k. lounge structural components.</i></p> <p><i>5 Years: Operational parts, controls, electrical, Lighting (except light ballasts, bulbs and power supply, see below), special or custom product, wood veneer products, Currents handcrank, Interaction Counterforce, KnollStudio, Spark Series seating structural elements, structural elements of all KnollStudio outdoor products including all Richard Schultz designed products, KnollExtra CPU storage and all universal storage drawers and Power Collection, Tone Tables.</i></p> <p><i>3 Years: Seating upholstery, textiles, leathers and finishes. Fabric boards textiles and Smokador Collection leathers.</i></p> <p><i>2 Years: Anchor Storage digital keypad lock, all other KnollExtra product</i></p> <p><i>1 Year: Light ballasts, bulbs and power supply, seating upholstered armpads and soft armpads, wood casegoods upholstered surfaces. KnollStudio, outdoor product finishes, k. lounge upholstery and k. lounge fabric.</i></p> <p>This warranty does not apply to:</p> <ul style="list-style-type: none">• Damage caused by a carrier other than the Seller.• Normal wear and tear or acts or omissions of parties other than Seller (including user modification, improper use or installation of Products).• COM or other third party materials applied to Products.• Products not installed by or under the auspices of a Knoll Dealer.• Dramatic temperature variations or exposure to unusual conditions.• Changes in surface finishes, including colorfastness due to aging or exposure to light.• Except as specifically noted above, textiles and upholstery supplied by <i>KnollTextiles</i> (consult current <i>KnollTextiles</i> price list for applicable warranty). <p>Natural variations occurring in wood, marble, and leather shall not be considered defects, and the Seller does not guarantee the colorfastness or matching of the colors, grains or textures, or surface hardness of such materials. The Seller also does not guarantee the colorfastness of fiberglass panel surfaces. THE EXPRESS WARRANTIES CONTAINED HEREIN ARE IN LIEU OF ALL OTHER WARRANTIES, EXPRESS OR IMPLIED, INCLUDING ANY WARRANTIES OF MERCHANTABILITY AND FITNESS FOR PARTICULAR PURPOSE AND ALL OTHER WARRANTIES ARISING FROM COURSE OF DEALING OR USAGE OF TRADE.</p> <p>The remedies provided above are the Purchaser's sole remedies for any failure of Seller to comply with its obligations regarding the workmanship of its Products. Correction of any nonconformity in the manner and for the period of time provided shall constitute complete fulfillment of all liabilities of Seller, with respect to or arising out of the Product furnished hereunder.</p>
Delay/Force Majeure	<p>Seller shall not be liable for failure to perform or for delay in performance due to fire, flood, strike or other labor difficulty, act of God, act of any governmental authority or of the Purchaser, riot, embargo, fuel or energy shortage, wrecks or delay in transportation, inability to obtain necessary labor, materials or manufacturing facilities from usual sources or failure of suppliers to meet their contractual obligations, or due to any cause beyond its reasonable control. If any such event occurs, Seller may extend delivery dates by a period of time necessary to overcome the effect of such delay, allocate available Product or cancel any purchase order.</p>
Compliance with Law	<p>PURCHASER IS SOLELY RESPONSIBLE FOR COMPLIANCE WITH ALL APPLICABLE FEDERAL, STATE AND LOCAL LAWS, ORDINANCES, REGULATIONS, RULES AND STANDARDS RELATING TO THE INSTALLATION, MAINTENANCE, USE AND OPERATION OF THE PRODUCTS.</p>
Patents	<p>Subject to the following provisions, Seller shall, at its own expense, defend or, at its option, settle any claim, suit or proceeding brought against the Purchaser, and/or its vendees, mediate and immediate, so far as based on an allegation that any Product or any part thereof furnished hereunder constitutes a direct or a contributory infringement of any claim of any patent of the United States or Canada. This obligation shall be effective only if Purchaser shall have made all payments then due hereunder and if Seller is notified promptly in writing and given authority, information and assistance for the defense of said claim, suit or proceeding. Seller shall pay all damages and costs awarded in such suit or proceedings so defended.</p> <p>The foregoing indemnity does not apply to the following:</p> <ul style="list-style-type: none">• Products supplied according to a design other than that of Seller, and which is required by the Purchaser.• Combination of the Product with another product not furnished hereunder unless Seller is a contributory infringer.• Any settlements of a suit or proceeding made without Seller's written consent.
Limitations of Liability	<p>SELLER, ITS CONTRACTORS, AUTHORIZED DEALERS AND SUBCONTRACTORS OR SUPPLIERS OF ANY TIER SHALL NOT BE LIABLE TO PURCHASER FOR ANY SPECIAL, INDIRECT, INCIDENTAL OR CONSEQUENTIAL DAMAGES ARISING FROM A BREACH OF THIS AGREEMENT.</p> <p>Purchaser's remedies set forth herein are exclusive and the liability of Seller with respect to the breach of this agreement or any contract entered into between the parties pursuant hereto shall not exceed the price of the Product or part on which such liability is based.</p>

General Ordering Information

The Products

This guide encompasses all standard products for this product group.

Sizes

Dimensions listed in this guide are indicated as:

H = height

W = width

D = depth

Dia. = diameter

Rad. = radius

Pricing

All prices shown are list.

How to Order

Select pattern numbers and quantities required for your complete installation. Product questions can be addressed in the specific sections of this guide or by contacting your sales representative or customer resource representative at 1-800-343-5665.

Next, select options (if required), along with colors and finishes appropriate to each product. Reference the Finishes and Fabrics pages for color designations.

On large installations, an item's "designated area" can be specified to assist in product organization and handling.

To expedite complete / correct entry of your order, be certain all pattern numbers, quantities, colors and area identifications are completely specified. Also, include complete purchase order numbers, bill-to and ship-to addresses, a contact name and specific factory shipping dates required.

Mail all orders to:

Knoll, Inc.

1235 Water Street

P.O. Box 157

East Greenville, PA 18041

Attention: Order Entry

Once your order is entered at Knoll, an acknowledgment will be mailed to you. You will be advised of your scheduled shipping date within five days of the original acknowledgment. If it is necessary to revise your order, please contact your customer resource representative.

Sustainability Statement

Sustainable design is a key component of Knoll's environmental focus. Our commitment to social responsibility and a healthy environment has prompted us to further articulate our longstanding environmental programs and, with encouragement and support from our colleagues in the industry, we have re-energized our focus on such "green" initiatives as life cycle analysis and LEED™ certification. Knoll is proud to have contributed to projects that have received LEED certification from the U.S. Green Building Council.

For the latest information on Knoll products that help our customers achieve LEED certification, log on to knoll.com, click on "About Knoll" and then "Environmental Focus."