

HOW TO SPECIFY

# DRAPERY



**Knoll**Textiles



Introduction . . . . . 3

Questions to Get You Started . . . . . 5

Fabric Choices . . . . . 6

Drapery Anatomy . . . . . 8

Drapery Terminology . . . . . 9

Select Your Drapery Header . . . . . 10

Define Your Drapery Details . . . . . 14

Shade Anatomy and Terminology . . . . . 19

Select Your Shade . . . . . 20

Choose Your Shade Options . . . . . 21

Specifications . . . . . 22

Credits . . . . . 28

HOW DO YOU ENVISION YOUR

# SPACE?

Use this brochure as a guide to help you select the right treatments for a new project or pre-existing space. Inside, you will find a summary of starting points to address when working with a client, an overview of key terminology, tips to aid you in the selection process, and inspiration for your space.

Developed in conjunction with drapery specialist Erik Bruce, this brochure will give you the essentials you need to take your project from beginning to end. Please visit [knolltextiles.com](http://knolltextiles.com) to view our extensive line of drapery. You can also contact your local KnollTextiles showroom for recommendations on drapery workrooms near you.



Ondo Drapery by KnollTextiles

What Is the Use?

- + **Light Control/Room Darkening**
- + **Privacy**
- + **Thermal Control/Energy Conservancy**
- + **Contract/Residential**
- + **Functional/Decorative**
- + **Single/Multiple Layers of Fabric**

How Will It Be Designed?

- + Will it be **Sill Length/Floor Length**?
- + What is the **Fabric Width/Fullness**?
- + Can the fabric be **Railroaded**?
- + Will it be **Inside/Outside Mount**?
- + What kind of **Hardware** will you need?
- + Is it a **Soffit** or **Drapery Pocket**?
- + How much **Stackback** off of the window do you want?

What Are the Logistics?

- + What is your **Timeline**?
- + What is your **Budget**?
- + Who will be your **Fabricator**? Will they also be your **Installer**?

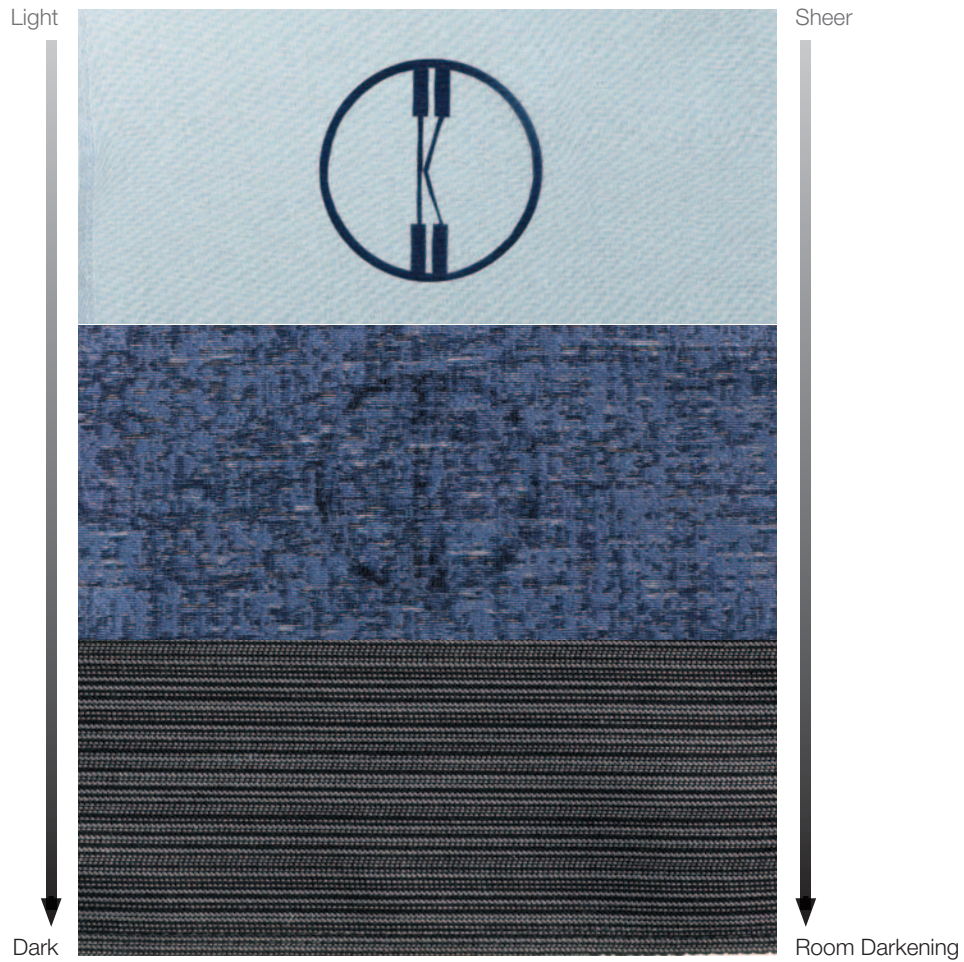

KnollTextiles Draperies from top to bottom: *Sheer Color*, *Quest*, and *Gallery*

Drapery transparency varies by fabric from sheer to room darkening. In the exercise above, three draperies have been placed in front of the same object under the same light conditions. At the top, the object is completely visible behind *Sheer Color*. When placed behind *Quest*, the object is just barely visible through the fabric's weave. Behind a room darkening fabric, *Gallery*, the object is totally obscured.



*Parker Drapery by Rodarte for Knoll Luxe*

# DRAPERY ANATOMY

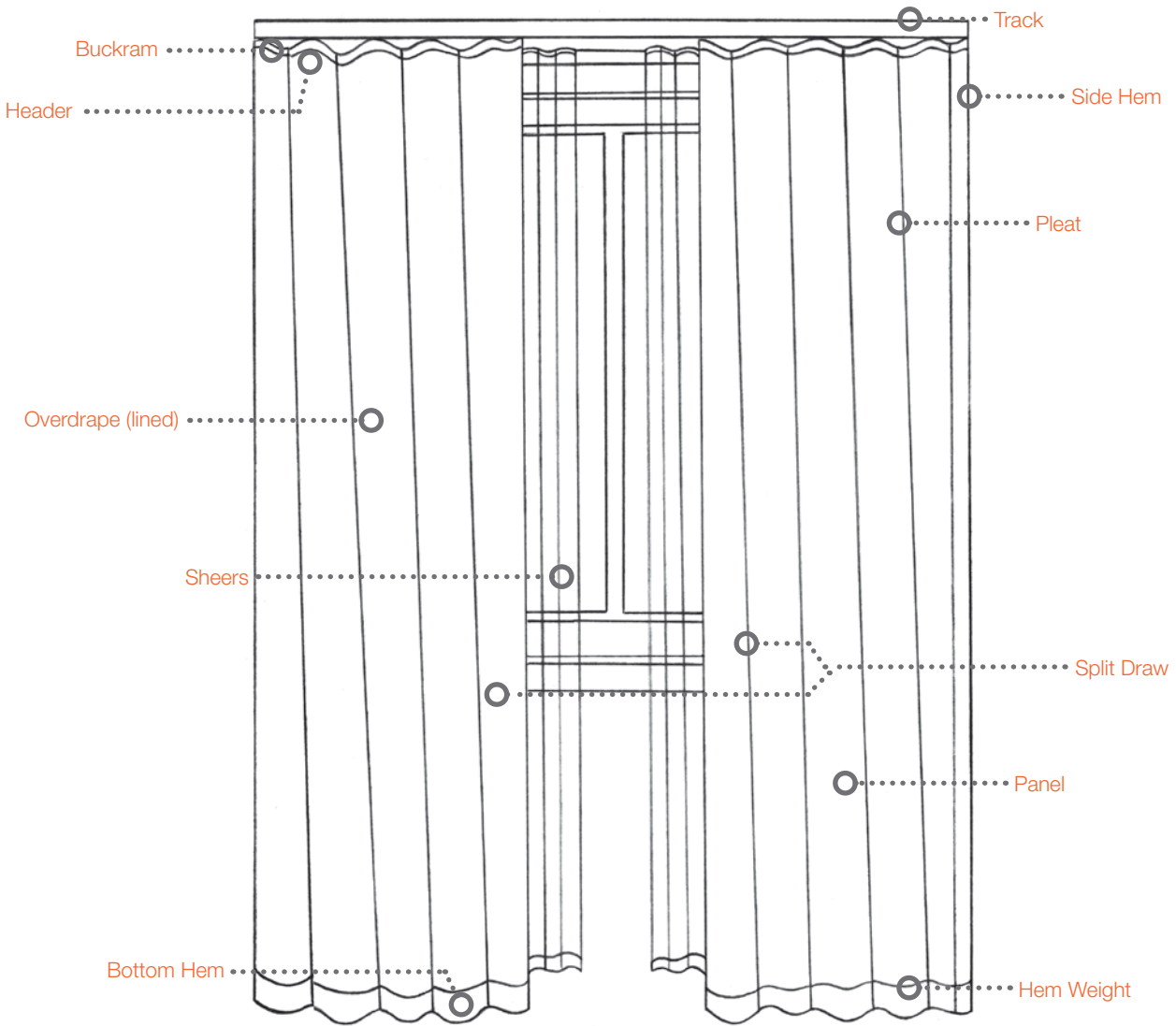



<b>Buckram</b> . . . . .	a stiff 100% polyester backing used as a stiffener for the inside of drapery headers. The standard amount of buckram needed to form pleating is 4 inches.
<b>Flame Treatment</b> . . . . .	a treatment that can be applied to drapery to make it less susceptible to catching fire. This treatment can be applied to fabrics that are not flame retardant, though tests must be made to ensure that fabrics can have this treatment applied. Fabrics that are already flame retardant do not need this treatment.
<b>Fullness</b> . . . . .	the quantity of fabric needed to make the window treatment. 0% fullness is the amount of fabric needed to cover the window opening, 100% is double that amount, and 200% is triple that amount.
<b>Hardware</b> . . . . .	any of the necessary components that are used to hang, open, or close a draped panel.
<b>Header</b> . . . . .	the way drapery is fabricated at the top of a window treatment. Headers can be pleated, shirred, tabbed, grommeted, etc. into different header styles.
<b>Hem Weight</b> . . . . .	weights that are inserted into drapery seams to ensure that they hang straight.
<b>Lining Fabrics</b> . . . . .	a fabric that is used behind a draped fabric to make drapery more opaque, flame retardant, water resistant, or heat insulating. It is also used to prevent fabric fading.
<b>Room Darkening</b> . . . . .	drapery that prevents most light from entering a space.
<b>Sheers</b> . . . . .	drapery that lets in an ample amount of light and is translucent.
<b>Side Hem</b> . . . . .	the folded back and sewn down fabric, which creates a finished border alongside the edge a drape.
<b>Soffit</b> . . . . .	the underside of a window frame where the drapery header is mounted.
<b>Split Draw</b> . . . . .	when fabric is stacked on both sides of a window.
<b>Stacking Reference</b> . . . . .	the direction that drapery is pulled opened and closed relative to the amount of fabric used.

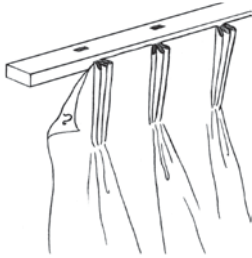

#### Pinch-pleat

- + **Pinch-pleats** are the most popular header styles for drapery. They offer a clean and even aesthetic that can be applied in a wide range of interiors—from traditional to contemporary spaces.
- + **Structure:** Each pleat on a pinch-pleat is composed of three evenly spaced folds.
- + **Advantages:** Low-cost and easy application.
- + **Add:** Trimming, tiebacks, lining, and interlining.

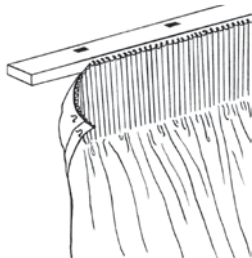

#### Pencil-pleat

- + **Pencil-pleats** offer a uniform, evenly spaced header style appropriate for both residential and corporate interiors.
- + **Structure:** This header style is given its name because of the thin width of each pleat.
- + **Advantages:** Softer overall look, less defined drape than pinch-pleat styles.
- + **Add:** Side or top treatments for added fullness.

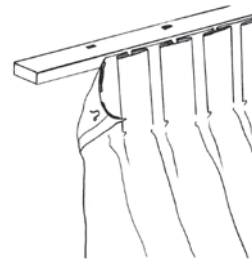

#### Box-pleat

- + **Box-pleat** styles use flat pleating to create a more geometric aesthetic.
- + **Structure:** This header style often requires the application of a heavy-duty buckram.
- + **Advantages:** Added fullness can emulate the look of stationary side panels and can support great weight.

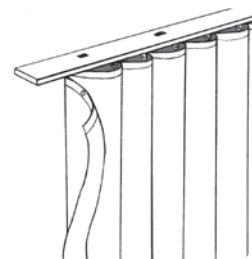

#### Ripplefold®

- + **Ripplefolds®** are the most flexible of the drapery header styles and create an even look from top to bottom. This header style traverses the track or hardware frictionlessly, creating a floating aesthetic. No buckram is necessary for Ripplefolds. Snap tape is used instead.
- + **Structure:** Ripplefold headers are hung below the track or hardware on snap and can be hand or cord drawn.
- + **Advantages:** Clean, uniform look, appropriate for a wide range of environments—from residential and commercial interiors.

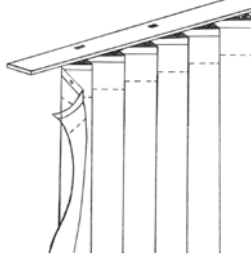

#### Accordia-Fold®

- + **Accordia-Fold®** header styles also offer an even look from top to bottom, but each ripple is pleated, making them a crisper alternative to the Ripplefold headers. Buckram is necessary in order to create a crisp pleat.
- + **Structure:** Accordia-Fold headers are hung below the track on snap and can be hand or cord drawn.
- + **Advantages:** Can be used as a substitute to traditional partitions, delivers a clean, uniform look front-to-back, best stacking rations, and highest stacking depth of all header styles.

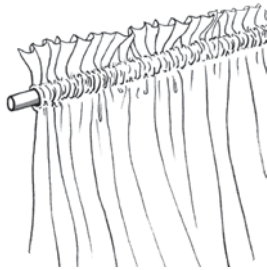

#### Shirred

- + **Shirred** headers add elegance and texture to draped surfaces.
- + **Structure:** Shirred headers are tightly gathered together. As a result, the overall body of the draped surface is less structured and more organic than many of the other header options. These are most often shirred directly over or onto a rod.
- + **Advantages:** Adds drama to the window plane and lends to spaces where extra fullness is desired.
- + **Add:** Decorative rods or rod finials to amplify the drama.

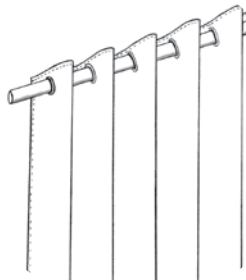

#### Grommet

- + **Grommet** headers create a uniform, structured look that is both modern and functional.
- + **Structure:** Equidistant circles are cut into the top of a draped fabric. Then circular metal grommets are secured within each one so that a curtain rod can slide right through with ease.
- + **Advantages:** Clean look with built in hardware that can be used in both residential and corporate interiors.
- + **Add:** Metal grommet in different finishes to complement color and material of draped fabric and rod.



*Cyclone Drapery* by KnollTextiles



*Parker Drapery by Rodarte for Knoll Luxe*

1

Determine Pocket Depth

The pocket is the top section of the drapery header where a rod is inserted. The pocket depth is the circumference of the loop where the rod is inserted plus 1/2 inch.

2





Choose Mount

+ Inside + Outside + Ceiling

3

Specify Hardware

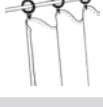
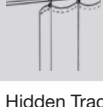
+ Track and Hardware options include:

Hardware	Operation	Compatible Drapery Headers
 <p>Hand Drawn</p>	Tracks that can be opened or closed by hand without the use of a cord. Batons (usually made of fiberglass) are attached to the track and used to pull open and close the drapery to prevent it from being torn or soiled.	+ Pinch-pleat + Ripplefold® + Grommet  + Pencil-pleat + Accordia-Fold®
 <p>Cord Drawn</p>	Tracks that are opened or closed by using a cord. Cords are built right into track set on a continuous loop so that they perform like a tension pulley.	+ Pinch-pleat + Box-pleat + Accordia-Fold®  + Pencil-pleat + Ripplefold®
 <p>Motor Drawn</p>	Tracks are opened and closed using electrical power or motor controls.	+ Pinch-pleat + Box-pleat + Accordia-Fold®  + Pencil-pleat + Ripplefold®
 <p>Rod and Ring</p>	This system uses a rod and rings to hang drapery. The drapery is attached to rings—using clips, hooks, or openings—which are then looped onto the rod.	+ Pinch-pleat + Box-pleat  + Pencil-pleat + Grommet
 <p>Exposed Track</p>	A track that does not conceal hardware or other tracking apparatus from plain sight.	+ Pinch-pleat + Box-pleat + Accordia-Fold®  + Pencil-pleat + Ripplefold® + Grommet
 <p>Hidden Track with Cornice</p>	A track that is concealed behind a cornice façade, obscuring any tracking apparatus from plain sight. Cornices are usually created from wood, which can be shaped, trimmed, padded, etc.	+ Pinch-pleat + Box-pleat + Accordia-Fold®  + Pencil-pleat + Ripplefold® + Shirred
 <p>Curved Track</p>	A track that is bent to fit a curved wall or special curved application.	+ Pinch-pleat + Box-pleat + Accordia-Fold® + Grommet  + Pencil-pleat + Ripplefold® + Shirred



Sheer Draperies by KnollTextiles

4

Choose Fullness

The fullness is amount of extra fabric used on a window, plus side hems and returns, which is quantified as a multiple of the size of the window opening, drapery rod, or track.

- + Ex: For a 30 in. pleated drapery panel with 100% fullness, use a fabric that is 60 in. wide.
- 100% fullness = 1 times fabric                      ex: 60 in. fabric = 30 in. pleated panel
- 150% fullness = 1.5 times fabric                  ex: 75 in. fabric = 30 in. pleated panel
- 200% fullness = 2 times fabric                    ex: 90 in. fabric = 30 in. pleated panel

5

Choose Stacking Direction

There are three main models for stacking drapery:



+ One way pull draperies are stacked on one side of a window opening.



+ Center opening draperies are stacked 50% on the left side of a window opening and 50% on the right side of a window opening.



+ Off-center opening draperies are stacked at different widths on either side of the window opening (ex: draperies stacked 60% on the left side and 40% on the right side). This model stacking reference may be used to create the illusion that a window is centered on the wall when it is not, allowing left and right drapery panels to meet in the center of the window.

6

Drapery Stacking Widths

The stacking width is the width measuring how much of the window will be covered when the drapes are open.

Opening Size	Ripplefold®	Accordia-fold®	Pinch-pleat	Box-pleat	Pencil-pleat	Yardage 100% of Sill (72 in.)	54 in. Wide Fabric Floor (102 in.)
32 in.	7 in.	7 in.	14 in.	16 in.	13 in.	5 yards	7 yards
54	7	7	20	24	18	7.5	10.5
76	8	8	25	31	23	10	14
98	14	14	30	38	27	12.5	17.5
120	17	17	36	46	32	15	21
142	21	21	41	53	37	17.5	24
164	23	23	47	60	42	20	28
186	28	28	52	67	47	22.5	31.5
208	30	30	58	75	52	25	35

7

Determine Hem Weights

- + **Corner Weight** – weights placed in the bottom corners of hem.
- + **String Weight** – a string of weights in the hem along the entire hemline.



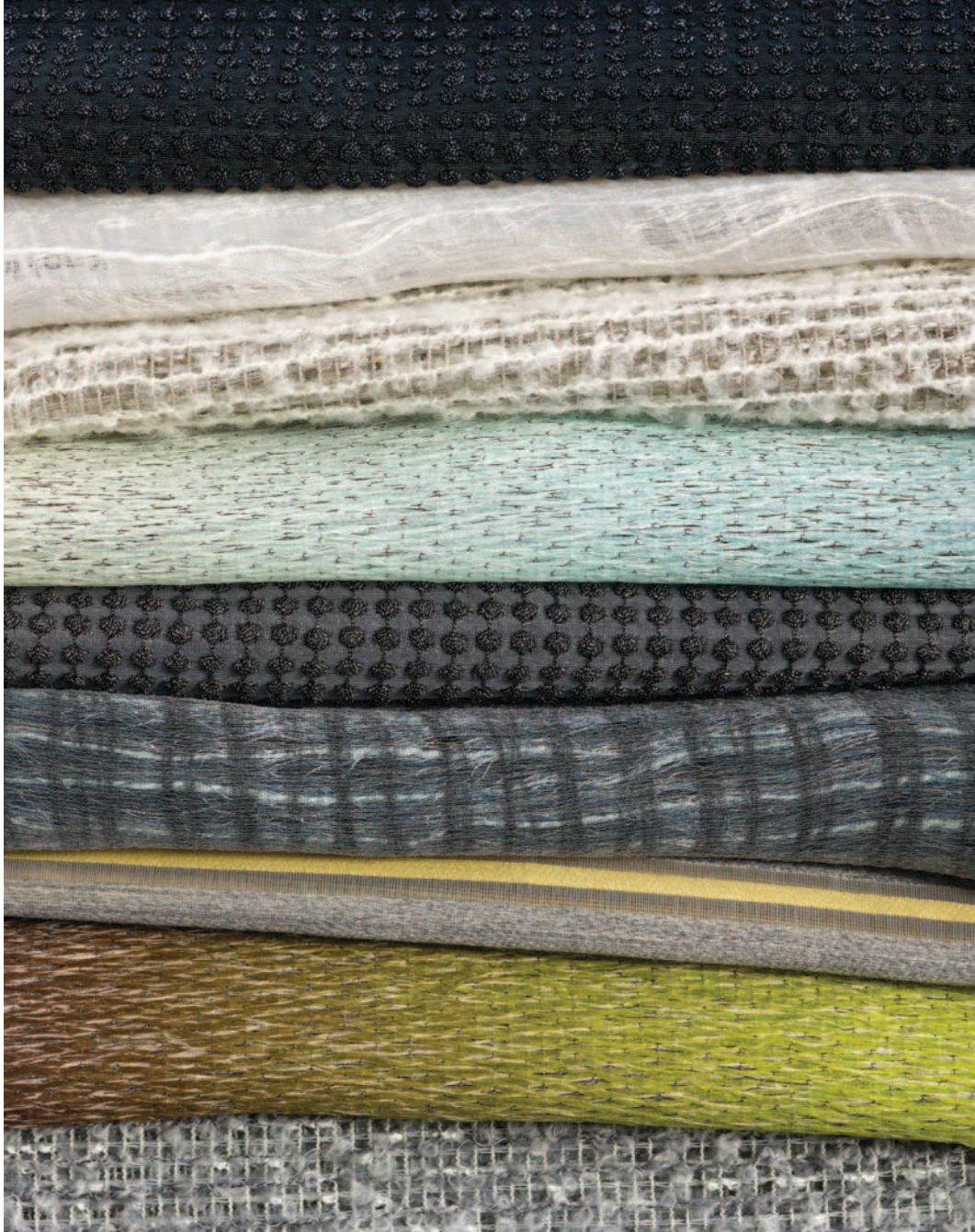

Knoll Luxe Draperies



*Auden* by Rodarte for Knoll Luxe

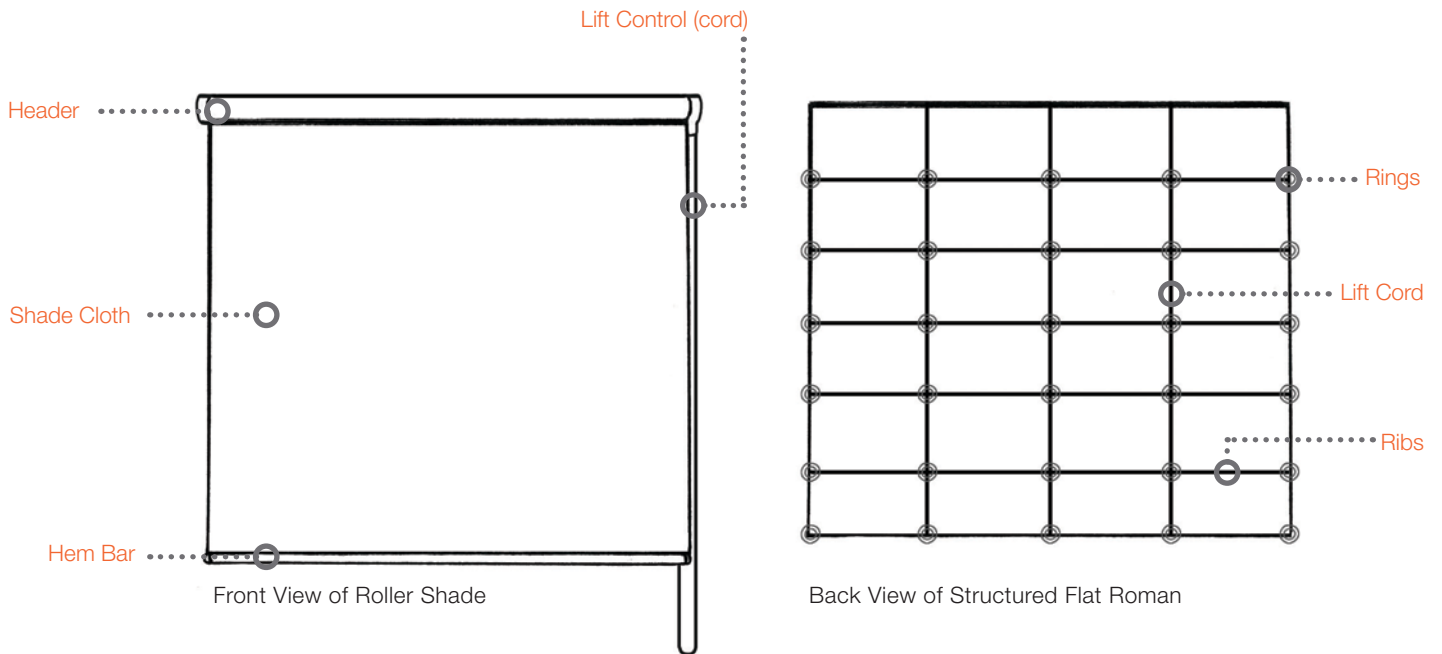

**Header** . . . . . the way a shade is mounted at the top of a window treatment. Headers can be on a roller, track, board, or rod.

**Hem Bar** . . . . . a bar that is attached to the bottom of a shade to weigh or pull it down.

**Lift Cord** . . . . . a cord that runs from the header of a shade down to the hem bar and can be pulled to draw the shade upward or downward.

**Lift Controls** . . . . . the manual or motorized components that are used to lift a shade. Manual lift controls include chain/clutch, cord/eyelets & cleat, or cord lock controls. Motorized lift controls include line voltage, low voltage, or battery operated controls.

**Rib** . . . . . ribs hold the entire width of a shade's folds in place and enforce folds, so they remain crisp as shades are pulled upward and downward.

**Ring** . . . . . rings are attached behind shades. Lift cords traverse rings, allowing the shade to move upward and downward and create folds at specified locations.

**Shade Cloth** . . . . . the fabric used to make a shade.

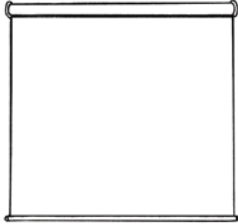

#### Roller Shade

- + **Roller** shades offer a clean, modern solution to blocking out or diffusing sunlight.
- + **Structure:** Fabric is attached to a bar and then rolled so that it hangs off the back of the bar. Roller shades can be installed as a standard roll—so that the roll is visible—or as a reverse roll—so that the roll is hidden.
- + **Advantages:** Roller shades take up little space and can be used alone or under drapery. The flat application of this shade shows off the fabric's pattern. Roller shades are also effective at keeping out noise and drafts.
- + **Add:** Motors, cords, chain/clutch, or trimming.



#### Hobbled Roman

- + **Hobbled Roman** shades create wide structured pleats down the surface of the window plane, adding elegance to a space.
- + **Structure:** These shades may be opened or closed by using a cord, chain, or motor. When shades are down, they have visible soft folds. When shades are up, the pleats evenly stack on themselves. Behind each fold, horizontal supports are attached to spacing tapes, maintaining the even structure of each pleat. Because each pleat is folded into itself, this treatment requires 1 ½ to 2 ½ times vertical fullness.
- + **Advantages:** Hobbled Romans maximize heat insulation and drapery opacity.
- + **Add:** Lining, blackout lining, shade cloth, or trimming.



#### Structured Flat Roman

- + **Flat Roman** shades add architecture to the window plane without adding extra volume, making them suitable for a wide range of spaces.
- + **Structure:** Flat Romans feature evenly spaced pleats that are separated every 6-8 inches and pressed flat against the surface of the shade.
- + **Advantages:** Flat Romans require less fabric than other decorative shade options.
- + **Add:** Lining, blackout lining, shade cloth, or trimming.



#### Soft Flat Roman

- + **Soft Flat Roman** shades add soft dimension to the window plane.
- + **Structure:** Soft Flat Romans feature fabric that is loosely pleated at the bottom so that the bottom center of the shade sags downward.
- + **Advantages:** This shade type requires less fabric than other decorative shade options.
- + **Add:** Lining, blackout lining, shade cloth, or trimming.

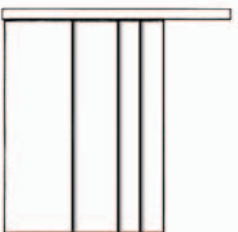

#### Sliding Panel System

- + **Sliding Panel Systems** can be used for a broad range of applications—whether they are used to block light on windows or used as a fabric wall to create privacy within interiors.
- + **Structure:** Sliding panel systems feature one or more totally flat drapery panels that slide along a track to open or close, stacking one behind the other. They may be hand drawn, cord drawn, or motorized.
- + **Advantages:** These shades require 0% fullness—so they require considerably less fabric than other shade options—and can be created using almost any fabric (except Rayon).
- + **Add:** Lining or shade cloth.

1

Specify Rod Mounting Depth

- + First rod mount is 3.5 inches from the wall.
- + Second rod mount is 6 inches from the wall.
- + When rod is a valence, the mount is 8 inches from the wall with a 4 inch minimum suggested.

2

Specify Hardware

Hardware	Compatible Shades
Bracket	+ Roller Shades
L-Bracket	+ Hobbled Roman + Structured Flat Roman + Soft Flat Roman
L-Bracket with Clip	+ Sliding Panel System
Valence	+ Roller Shades + Hobbled Roman + Structured Flat + Soft Flat Roman Roman + Sliding Panel System

3

Choose Shade Lift Controls

Manual Shade Lift Controls:

- + Chain/Clutch
- + Cord/Eyelets & Cleat
- + Cord Locks

Motorized Shade Lift Controls:

- + Line Voltage
- + Low Voltage
- + Battery

4

Choose Mount

- + Inside
- + Outside

# Specifications

## PART 1—GENERAL

### A. Description

1. General: Provide operable draperies/shades in accordance with this document and plans.
2. Related work specified elsewhere.
  - a. Rough carpentry for wood blocking and support ground.
  - b. Miscellaneous metal for framing and reinforcing.
  - c. Optional: Electrical power requirements and controls for motorized draperies, shades, or panels.

### B. Quality Assurance

1. Provide operable draperies from a firm that has specialized in the fabrication and installation of such work for at least five years in projects of similar size and scope.
2. Provide operable draperies, shade, or panels as complete units produced by a single manufacturer, including the necessary mounting brackets, hardware, fittings, fastenings, and installation.
3. Installation shall be performed by an authorized manufacturer's representative experienced in the installation and maintenance of such assemblies.

### C. Standards

1. Except as modified by governing codes and contract documents, comply with applicable provisions and recommendations of the following:
  - a. When required by fire codes, fabrics shall be flame resistant in accordance with NFPA-701 test requirements.
  - b. Flameproofing shall leave the fabric cleanable, dimensionally stable, and resistant to U.V. deterioration.
  - c. Optional: All electrical components and systems shall be performed to National Electric Code (N.E.C.) standards.

### D. Submittals

1. Manufacturer's Data: Submit specifications, operating, and installation instructions for draperies, shades, or panels.
2. Shop Drawings: Submit drawings for draperies, including dimensioned plans, seaming instructions, details, connections, anchorages, and the relation to adjacent construction.
3. Samples: Submit 24 x 24 in. samples of fabric(s) as specified and operable hardware with cut sheets.
4. Maintenance Instructions: Submit manufacturer's printed instructions for cleaning and maintenance of the products.
5. Optional: Submit wiring diagrams, detailing the wiring for motorized operation, relays, low-voltage interfaces, and switch locations.

### E. Product Delivery, Storage, and Handling

1. Subcontractor shall not deliver the draperies until room(s) containing draperies are painted and ready for drapery installation. Draperies and components shall be protected from damage during delivery and installation.

### F. Warranty

1. A written warranty agreeing to repair or replace hardware or fabric due to faulty workmanship, or installation for a period of one year.

## PART 2—PRODUCT

### A. Manufacturer

1. General: Provide operable drapery fabric as produced by KnollTextiles, which establishes the quality standards required and complies with contract documents.

## PART 3—EXECUTION

### A. Examination

1. Examine substrates, adjoining construction and conditions under which the work is to be installed. The work shall proceed until unsatisfactory conditions have been corrected.

### B. Preparation

1. Install draperies, shades, or panels with hardware in accordance with manufacturer's recommendations.
2. Draperies: Hang draperies so that the top of the heading clears the ceiling above by ¼ in. and the bottom hem clearance is a maximum of 1 in. from the finished floor or ½ in. from the sill line.

Shades and Panels: Hang shades plumb and square, running up and down. Set appropriate stops, and leave in the open position.

3. Drapery, shades, or panels shall be free of creases and wrinkles after hanging and shall be steamed and dressed down as required.

### C. Protection

1. Protect drapery, shades, or panels from soiling or damage after hanging.

\* These specifications are meant as a general guide. Please contact a professional drapery workroom when specifying a project. KnollTextiles is not responsible for any claims resulting from the use of the specifications listed in this brochure.

## DRAPERY HEADER SPECIFICATIONS

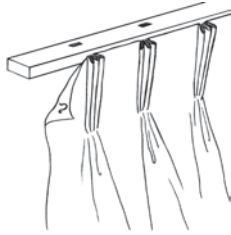

### Pinch-Pleat Header

1. Select your fabric.
2. Drapery heading shall be fabricated as follows: 4 in. of permanent-finish buckram shall be double folded into the heading (3 thicknesses of fabric) and sewn with either clear monofilament or triple-strand polyester thread, color matched to the fabric used. On unlined draperies, the bottom of the buckram shall be sewn to the face of the fabric. Pinch-pleats shall be bar tacked 1 in. from the bottom of the buckram, creating 3 folds in the fabric.
3. Drapery fullness shall be \_\_\_\_\_ plus 10 in. added for the center-opening overlap or 5 in. returns added for one-way openings.
4. Side hems shall be 1 ½ in. wide and double turned, consisting of three layers of fabric and blind-stitched so that stitches are not visible on the face of the fabric. All vertical seaming shall be sewn with a twin-needle serging machine with selvage trimmed and overlocked. Where patterned fabrics are used, widths shall be joined so that all patterns match perfectly. All vertical seams shall lie flat and straight without puckering.
5. Bottom hems are to be 4 in., double turned to consist of three layers of fabric, and blind-stitched. 1 in. square lead weights shall be securely sewn at each seam and at the corners. For sheer or light fabrics, string weights shall be inserted in hems.
6. All seams shall be hidden behind the pleats.
7. If less than a full width of fabric is required to accomplish the specified fullness, no less than one-half widths shall be used, and they shall be located at the extreme ends of each drapery panel.
8. Drapery Hardware: Kirsch no. \_\_\_\_\_ system. Other manufacturers' products that satisfy specified requirements will be considered. Assembled sets shall be provided, complete with all the components required, to sustain imposed loads and to perform the functions shown for the respective locations.
9. Optional: Linings shall be equal to the widths of the face fabric, joined to the face at the top using an inside-invisible seam and, at the side hems, hand-stitched and shadowed with a 1 ½ in. return of the face fabric. Interlining shall extend from the top pleat to within ½ in. of the hem of the lining and to extend to the leading edge of the side hems to create a full-shadowed appearance.

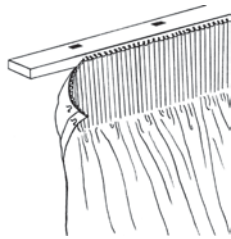

### Pencil-Pleat Header

1. Select your fabric.
2. Drapery heading shall be fabricated as follows: 4 in. of double folded fabric (3 thicknesses) shall be sewn to the face of a 4 in. pleating tape with either clear monofilament or triple-strand polyester thread, color matched to the fabric used. Pleating tape shall produce a uniform 3/8 in. heading.
3. Drapery fullness shall be \_\_\_\_\_ plus 12 in. added for the center-opening overlap or 6-in. returns added for one-way openings.
4. Side hems shall be double turned (3 layers of fabric) 1 ½ in. wide. Side hems shall be blind-stitched, so that stitches are not visible on the face of the fabric. All vertical seaming shall be sewn with a twin-needle serging machine with selvage trimmed and overlocked. Where patterned fabrics are used, widths shall be joined so that all patterns match perfectly. All vertical seams shall lie flat and straight without puckering.
5. Bottom hems are to be 4 in., double turned to consist of three layers of fabric, and blind-stitched. 1 in. square lead weights shall be securely sewn at each seam and at the corners. For sheer or light fabrics, string weights shall be inserted in hems.
6. All seams shall be hidden behind the pleats.
7. If less than a full width of fabric is required to accomplish the specified fullness, no less than one-half widths shall be used, and they shall be located at the extreme ends of each drapery panel.
8. Drapery Hardware: Kirsch no. \_\_\_\_\_ system. Other manufacturers' products that satisfy specified requirements will be considered. Assembled sets shall be provided, complete with all the components required, to sustain imposed loads and to perform the functions shown for the respective locations.
9. Optional: Linings shall be equal to the widths of the face fabric, joined to the face at the top using an inside-invisible seam and, at the side hems, hand-stitched and shadowed with a 1 ½ in. return of the face fabric. Interlining shall extend from the top pleat to within ½ in. of the hem of the lining and to extend to the leading edge of the side hems to create a full-shadowed appearance.

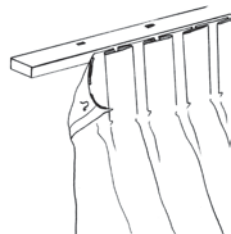

### Box-Pleat Header

1. Select your fabric.
2. Drapery heading shall be fabricated as follows: 4 in. of permanent-finish buckram shall be double folded into the heading (3 thicknesses of fabric) and sewn with either clear monofilament or triple-strand polyester thread, color matched to the fabric used. On large openings, 4 in. webbing shall be used. The bottom of the buckram shall be sewn to the face of the fabric. Spaces between the pleats shall be uniform.
3. Drapery fullness shall be \_\_\_\_\_ plus 12 in. added for the center-opening overlap or 6-in. returns added for one-way openings.
4. Side hems shall be double turned (3 layers of fabric) 1 ½ in. wide. Side hems shall be blind-stitched, so that stitches are not visible on the face of the fabric. All vertical seaming shall be sewn with a twin-needle serging machine with selvage trimmed and overlocked. Where patterned fabrics are used, widths shall be joined so that all patterns match perfectly. All vertical seams shall lie flat and straight without puckering.
5. Bottom hems are to be 4 in., double turned to consist of three layers of fabric, and blind-stitched. 1 in. square lead weights shall be securely sewn at each seam and at the corners. For sheer or light fabrics, string weights shall be inserted in hems.

6. All seams shall be hidden behind the pleats.
7. If less than a full width of fabric is required to accomplish the specified fullness, no less than one-half widths shall be used, and they shall be located at the extreme ends of each drapery panel.
8. Drapery Hardware: Kirsch no. \_\_\_\_\_ system. Other manufacturers' products that satisfy specified requirements will be considered. Assembled sets shall be provided, complete with all the components required, to sustain imposed loads and to perform the functions shown for the respective locations.
9. Optional: Linings shall be equal to the widths of the face fabric, joined to the face at the top using an inside-invisible seam and, at the side hems, hand-stitched and shadowed with a 1 ½ in. return of the face fabric. Interlining shall extend from the top pleat to within ½ in. of the hem of the lining and to extend to the leading edge of the side hems to create a full-shadowed appearance.



Ripplefold® Header

1. Select your fabric.
2. Drapery heading shall be fabricated as follows: Heading system shall use a woven snap tape, which is permanently stiffened to hold the drapery heading erect. The tape shall be 7/8 in. wide with nickel-plated snaps spaced every 4 in. and shall be sewn at the top and bottom to a double turned 7/8 in. top hem. The tape, with a shrinkage of less than 3%, may be washed or dry cleaned.
3. Fabrication shall be in accordance with the fabrication charts published by the Kirsch Company and in conjunction with the following specifics: drapery fullness shall be 60%, 80%, 100%, or 120%.
4. Side hems shall be double turned (3 layers of fabric) 1 ½ in. wide. Side hems shall be blind-stitched, so that stitches are not visible on the face of the fabric. All vertical seaming shall be sewn with a twin-needle serging machine with selvage trimmed and overlocked. Where patterned fabrics are used, widths shall be joined so that all patterns match perfectly. All vertical seams shall lie flat and straight without puckering.
5. Bottom hems are to be 4 in., double turned to consist of three layers of fabric, and blind-stitched. 1 in. square lead weights shall be securely sewn at each seam and at the corners. For sheer or light fabrics, string weights shall be inserted in hems.
6. All seams shall be hidden behind the pleats.
7. If less than a full width of fabric is required to accomplish the specified fullness, no less than one-half widths shall be used, and they shall be located at the extreme ends of each drapery panel.
8. Drapery Hardware: Kirsch no. \_\_\_\_\_ system. Other manufacturers' products that satisfy specified requirements will be considered. Assembled sets shall be provided, complete with all the components required, to sustain imposed loads and to perform the functions shown for the respective locations.
9. Optional: Linings shall be equal to the widths of the face fabric, joined to the face at the top using an inside-invisible seam and, at the side hems, hand-stitched and shadowed with a 1 ½ in. return of the face fabric. Interlining shall extend from the top pleat to within ½ in. of the hem of the lining and to extend to the leading edge of the side hems to create a full-shadowed appearance.

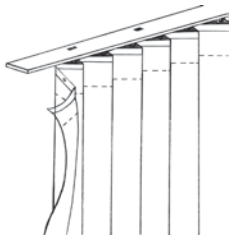

Accordia-Fold® Header

1. Select your fabric.
2. Drapery heading shall be fabricated as follows: Accordia-Fold heading system shall consist of a 8 ½ in. snap tape along with 4 in. buckram double turned three thicknesses sewing snap tape top and bottom placed at 1/8 in. top header. 3 ½ in. plastic pleater strip that is sewn top and bottom to the drapery heading. The pleater shall be spaced in ¼ in. increments so as to create evenly spaced "V" pleats. The pleater may be washed or dry cleaned.
3. Fabrication shall be in accordance with the fabrication charts published by the Kirsch Company and in conjunction with the following specifics: drapery fullness shall be 60%, 80%, 100%, or 120%.
4. Side hems shall be double turned (3 layers of fabric) 1 ½ in. wide. Side hems shall be blind-stitched, so that stitches are not visible on the face of the fabric. All vertical seaming shall be sewn with a twin-needle serging machine with selvage trimmed and overlocked. Where patterned fabrics are used, widths shall be joined so that all patterns match perfectly. All vertical seams shall lie flat and straight without puckering.
5. Bottom hems are to be 4 in., double turned to consist of three layers of fabric, and blind-stitched. 1 in. square lead weights shall be securely sewn at each seam and at the corners. For sheer or light fabrics, string weights shall be inserted in hems.
6. If less than a full width of fabric is required to accomplish the specified fullness, no less than one-half widths shall be used, and they shall be located at the extreme ends of each drapery panel.
7. Drapery Hardware: Kirsch no. \_\_\_\_\_ system. Other manufacturers' products that satisfy specified requirements will be considered. Assembled sets shall be provided, complete with all the components required, to sustain imposed loads and to perform the functions shown for the respective locations.
8. Optional: Linings shall be equal to the widths of the face fabric, joined to the face at the top using an inside-invisible seam and, at the side hems, hand-stitched and shadowed with a 1 ½ in. return of the face fabric. Interlining shall extend from the top pleat to within ½ in. of the hem of the lining and to extend to the leading edge of the side hems to create a full-shadowed appearance.



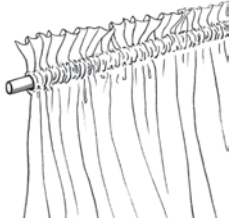

**Shirred Header**

1. Select your fabric.
2. Drapery heading shall be fabricated as follows: A top hem consisting of 2 layers of fabric shall be sewn with either clear monofilament or triple-strand polyester thread, color matched to the fabric used, so as to create a pocket of an appropriate width that permits the insertion of a \_\_\_\_\_ in. diameter pole or rod (metal or wood). A \_\_\_\_\_ in. wide hem shall extend above the pocket.
3. Drapery fullness shall be \_\_\_\_\_%. Pocket size shall be 10% larger than 1/2 of the circumference of the pole.
4. Bottom hems shall be double-turned 2 in 4 in. and shall consist of three layers of fabric and blind stitched.
5. If less than a full width of fabric is required to accomplish the specified fullness, no less than one half widths shall be used, and they shall be located at the extreme ends of each drapery panel.
6. Hardware shall be \_\_\_\_\_ in. diameter wood or metal rod that can be wall or ceiling mounted.
7. Operations: Heading shall be stationary.

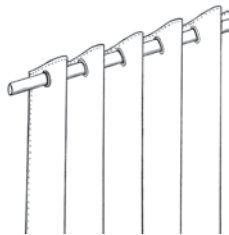

**Grommet Header**

1. Select your fabric.
2. Drapery heading shall be fabricated as follows: 4 in. of permanent finish buckram shall be double-folded into the heading (3 thicknesses of fabric) and sewn with either clear monofilament or triple-strand polyester thread, color matched to the fabric used. The 4 in. bottom of the buckram shall be sewn to the face of the fabric. #7 grommets (1 1/2 in. diameter with a 1/2 in. rim) or #8 grommets (1 in. diameter with a 3/8 in rim) shall be uniformly set across the heading, 5 in. 8 in. apart with the first and last 2 in. from each end. This must be an even number of grommets.
3. Drapery fullness shall be \_\_\_\_\_%.
4. Side hems shall be double-turned 1 1/2 in. wide. Side hems shall consist of three layers of fabric and be blind stitched so that stitches are not visible on the face of the fabric. All vertical seaming shall be sewn with a twin-needle serging machine with selvage trimmed and over locked.
5. Bottom hems are to be 4 in. double-turned to consist of three layers of fabric and be blind stitched. 1 in. sq. lead weights shall be securely sewn at each seam and at the corners. For sheer or light fabrics, string weights shall be inserted into hems.
6. If less than a full width of fabric is required to accomplish the specified fullness, no less than one half shall be used, and they shall be located at the extreme ends of each drapery panel.
7. Pole finish: chrome, brass, or wood.
8. Optional: Linings shall be equal to the widths of the face fabric, joined to the face fabric at the top using an inside invisible seam, and at the side hems, hand stitched and shadowed with a 1 1/2 in. return of the face fabric. Interlining shall extend from the top pleat with 1/2 in. of the hem of the lining and to extend to the leading edge of the side hems to create a full-shadowed appearance.

**SHADE FABRICATION SPECIFICATIONS**



**Hobbled Roman**

1. Select your fabric.
2. Double Roman shades shall be fabricated with even folds cascading the full length of the shade. The shade shall be lined. The flat-fabric length shall be 2 1/2 times the shade length.
3. Spacing tapes or rings shall not exceed 12 in. on center and be secured to the face fabric without the attachments showing.
4. Side hems shall be single-turned 3/4 in. wide, shall consist of three layers of fabric, and shall be blind stitched to the lining. All vertical seaming shall be serged and pressed.
5. Bottom hems shall be double-turned 2 in. and shall consist of three layers of fabric and be blind stitched. An aluminum hem bar shall be inserted full width of the bottom hem and stitched closed.
6. For shades wider than the fabric width, full widths of the fabric must be centered with equal widths added to each side; no center seams are allowed. If the fabric is to be railroaded, special notes must be included in the submittals.
7. Linings shall be equal to the width of the face fabric and shall be joined to the face fabric at the top. Bottom and sides shall be tacked to the body as required.
8. Hardware: Headrail shall be 1 1/2 x 3/4 in. extruded aluminum, with an integral channel to receive the attachment spline from the shade. The cord lock shall be integrated into the headrail which is the crash-proof and self-aligning. Optional motorized headrail shall be 2 1/4 x 2 1/4 in. with an integrated motor and lift system.



**Structured Flat Roman**

1. Select your fabric.
2. Flat Roman shades shall be fabricated without sagging or distortion. Shades shall be lined or unlined as outlined below.
3. Spacing tapes and or rings shall not exceed 12 in. on center and be secured to the face fabric without the attachments showing. For extra-flap Roman shades, folds shall be added to the bottom of the shade.
4. Side hems shall be single-turned  $\frac{3}{4}$  in. wide, shall consist of two three layers of fabric, and shall be blind stitched to the lining. All vertical seaming shall be serged and pressed.
5. Bottom hems shall be double-turned 2 in. wide, shall consist of three layers of fabric, and be blind stitched. An aluminum hem bar shall be inserted full width of the bottom hem and stitched closed. For less structure, four strands of string weights can be inserted into the hem, instead of a hem bar.
6. For shades wider than the fabric width, full widths of the fabric must be centered with equal widths added to each side; no center seams are allowed. If the fabric is to be railroaded, special notes must be included in the submittals.
7. Linings shall be equal to the width of the face fabric and shall be joined to the face fabric at the top. Bottom and sides shall be tacked to the body as required.
8. Hardware: Headrail shall be  $1\frac{1}{2} \times \frac{3}{4}$  in. extruded aluminum, with an integral channel to receive the attachment spline from the shade. The cord lock shall be integrated into the headrail which is the crash-proof and self-aligning. Optional motorized headrail shall be  $2\frac{1}{4} \times 2\frac{1}{4}$  in. with an integrated motor and lift system.



**Soft Flat Roman**

1. Select your fabric.
2. Soft Flat Roman shades shall be fabricated with sagging. Shades shall be lined or unlined as outlined below.
3. Spacing tapes and rings shall not be less 16 in. on center and be secured to the face fabric without the attachments showing. For extra swoop, rings shall be 16 in. on center, and folds shall be added to the bottom of the shade. Spacing tapes and rings shall be on side hem.
4. Side hems shall be single-turned  $\frac{3}{4}$  in. wide, shall consist of two layers of fabric, and shall be blind stitched to the lining. All vertical seaming shall be sewn with a single-needle sewing machine and pressed flat.
5. Bottom hems shall be single-turned  $\frac{3}{4}$  in. wide, shall consist of two layers of fabric, and be blind stitched. An aluminum hem bar shall be inserted full width of the bottom hem and stitched closed. For less structure, four strands of string weights can be inserted into the hem, instead of a hem bar.
6. For shades wider than the fabric width, full widths of the fabric must be centered with equal widths added to each side; no center seams are allowed. If the fabric is to be railroaded, special notes must be included in the submittals.
7. Linings shall be equal to the width of the face fabric and shall be joined to the face fabric at the top. Bottom and sides shall be tacked to the body as required.
8. Hardware: Headrail shall be  $1\frac{1}{2} \times \frac{3}{4}$  in. extruded aluminum, with an integral channel to receive the attachment spline from the shade. The cord lock shall be integrated into the headrail which is the crash-proof and self-aligning. Optional motorized headrail shall be  $2\frac{1}{4} \times 2\frac{1}{4}$  in. with an integrated motor and lift system.

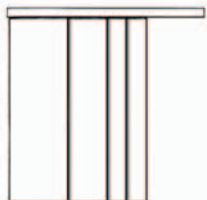

**Sliding Panel System**

1. Select your fabric.
2. Each panel shall be fabricated with a 2 in. bottom hem with a sewn-in aluminum bar,  $\frac{1}{2}$  in. side hems, and a 1 in. reinforced top hem with Velcro. Each panel section shall be attached to a panel glide. All hems shall be single-needled so as not to catch stitching when sliding past each other or when stacking blind-stitched so as to eliminate all visible stitching. The configuration is mounted on an aluminum PT109 track system that allows the panel to slide on its own channel by hand or cord traverse.

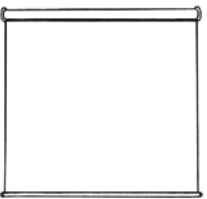

**Roller Shades/Clutch Systems**

1. Select your fabric.
2. Select inside or outside mount.
3. Choose regular roll or reverse roll.
4. Specify manual or clutch system.
5. Optional: Add fascia to hide toproll shade up into.



Room Darkening Draperies by KnollTextiles



*Auden* Drapery by Rodarte for Knoll Luxe

On Cover: *Danube* Drapery by Dorothy Cosonas for Knoll Luxe

**Credits**

Erik Bruce, *Drapery Specialist*

Judy Collins, *Drapery Production Manager/Sales at Craftsman Window Coverings*

Laura Rosenbaum, *Illustrations*

knolltextiles.com 866.565.5858

©2012 KnollTextiles. All rights reserved.

**KnollTextiles**