

Dividends Horizon® D2 Snap Fit Tile Support

1. Attach 2 tile rail frame brackets to panel frame using 1 #10-24 x 3/8" thread forming screws on each. (Fig. 1)

Note: Install bracket with mounting hole towards the bottom. The notch feature on each bracket must be facing up regardless of side. (Fig. 1B)

2. Place non-cut (Plain) end of tile rail inside large tabs of mounting bracket. Position rectangular cutouts of the tile rail over small tabs of mounting bracket. Snap into place. (Fig. 2)

3. Tile support attached to outside of mounting bracket. (Snaps engaged.) (Fig. 2B)

continued...

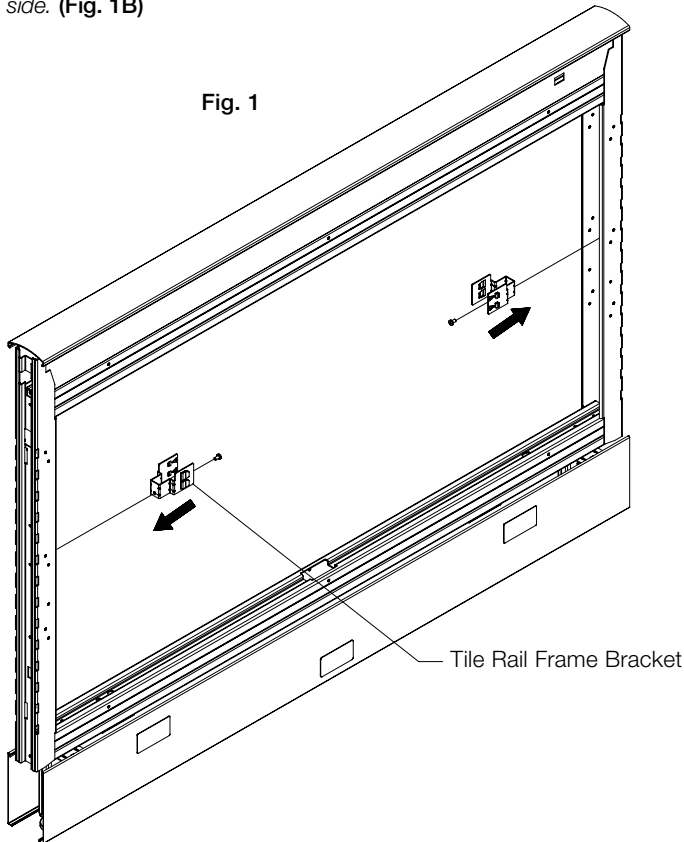

Fig. 1

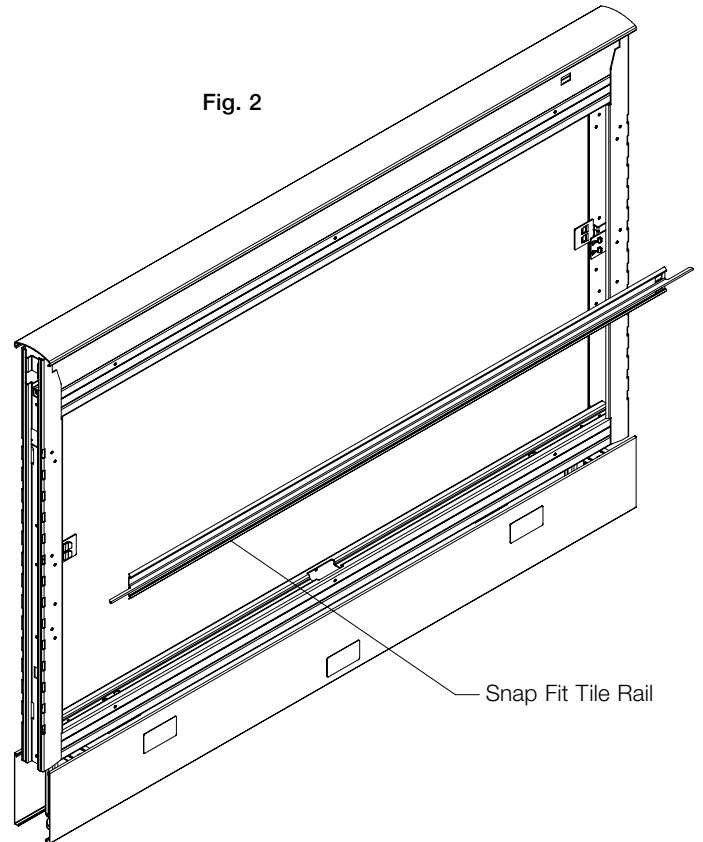

Fig. 2

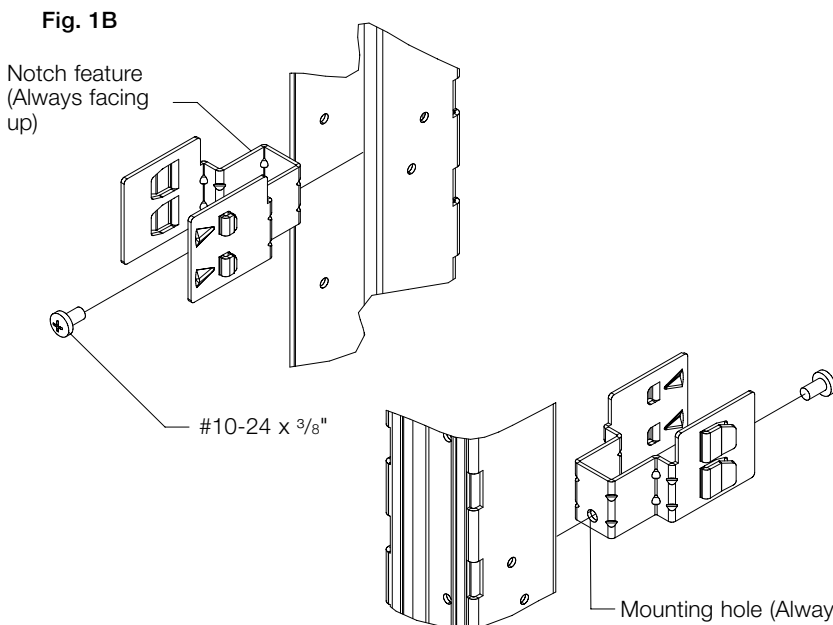

Fig. 1B

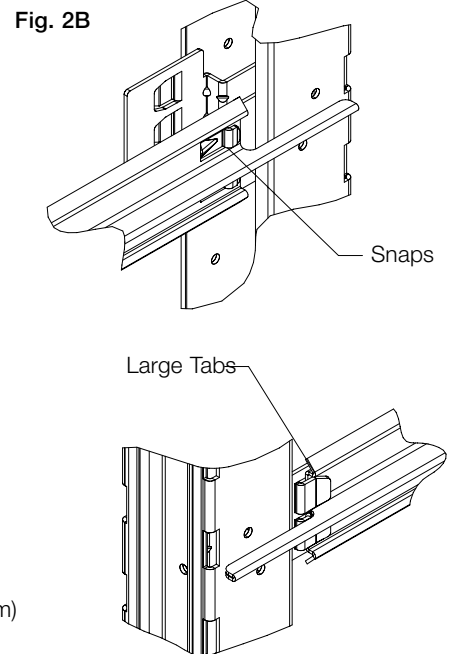

Fig. 2B

Dividends Horizon D2 Snap Fit Tile Support, continued

4. After all tile supports are attached, if Top/Bottom skin clips are not preinstalled, insert top/bottom alignment clips into skins. Locations shown below. (Fig. 3)

- Note:**
1. For fabric inserts located in the top position of the panel, install Top/Bottom alignment clips in the bottom edge of insert only. (Fig. 3B)
 2. For fabric inserts located in the bottom position of the panel, install Top/Bottom alignment clips in the top edge of insert only. (Fig. 3B)

3. If top/bottom Top/Bottom skin clips are preinstalled, removed unneeded clips and discard.

Fig. 3

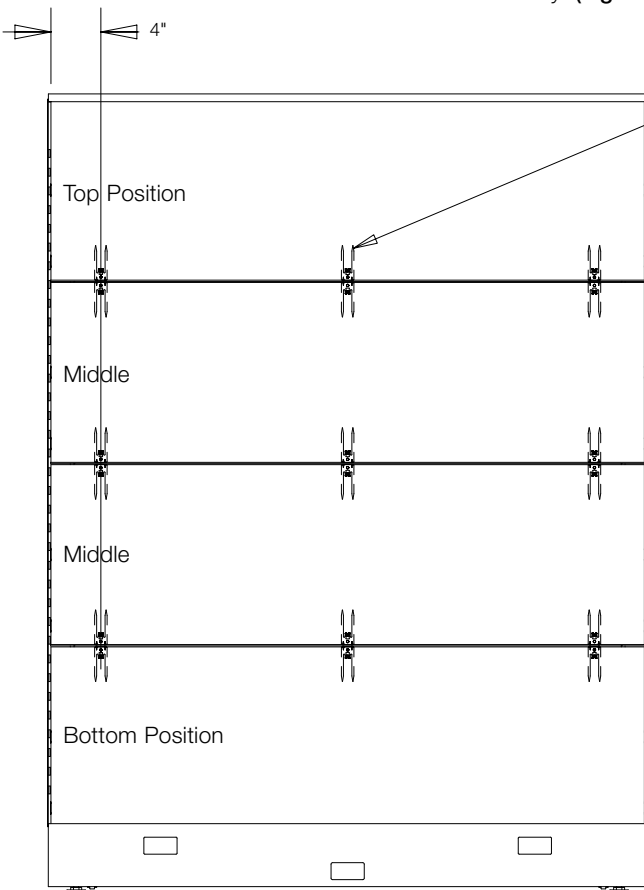

36"-48" Wide Panels

60" Wide tiles get two skin clips in the center. Install each clip 21" in from the edge

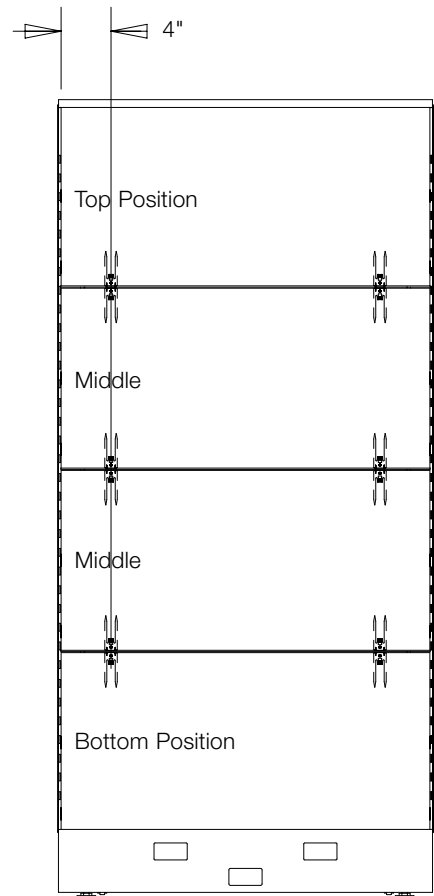

18"-30" Wide Panels

FIG 3B:

Top/Bottom Skin Clip

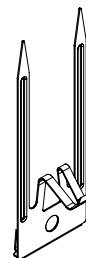

DISASSEMBLY FOR RECYCLING

Materials Identification and Segregation:

Where possible plastic components are marked with ASTM recycling codes. Use these codes to identify material type for recycling. Non-marked components should

be treated as mixed plastic. Ferrous metals can be identified using a small magnet for recycling. Non-ferrous metals should be separated and recycled separately.

To disassemble product, reverse the above installation steps.