

Dividends Horizon® Chicago Electrical Retro-Fit Kit

For installing DE1 series Chicago electrical components on DP7 series Dividends panels

1. Fasten retro-fit mounting bracket to cast aluminum foot with self drilling screws, as shown.
2. Bracket is self-locating on the cast foot. Use the holes in the mounting bracket as a drilling template for the screws.

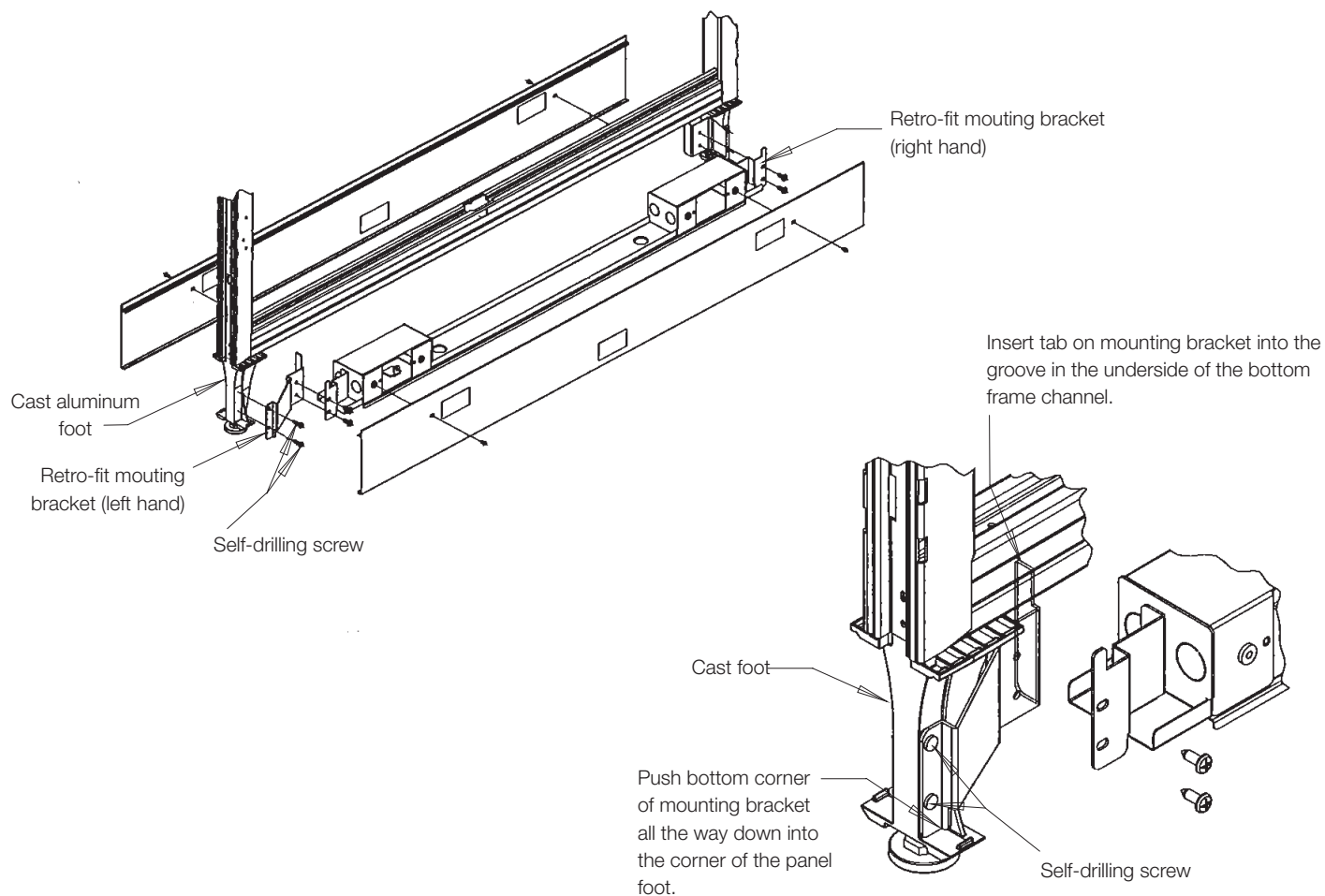

DISASSEMBLY FOR RECYCLING

Materials Identification and Segregation:

Where possible plastic components are marked with ASTM recycling codes. Use these codes to identify material type for recycling. Non-marked components should be treated as mixed plastic. Ferrous metals can be identified using a small magnet for recycling. Non-ferrous metals should be separated and recycled separately.

To disassemble product, reverse the above installation steps.