

Bookcase Ganging Kit

Reference Number: 6TP00436

Tools Needed

- Drill gun
- Phillips driver bit

1. Installation Instructions for Wall Storage Units Wall Attachment

Note: All wall storage units must be attached to a wall or back to back to each other.

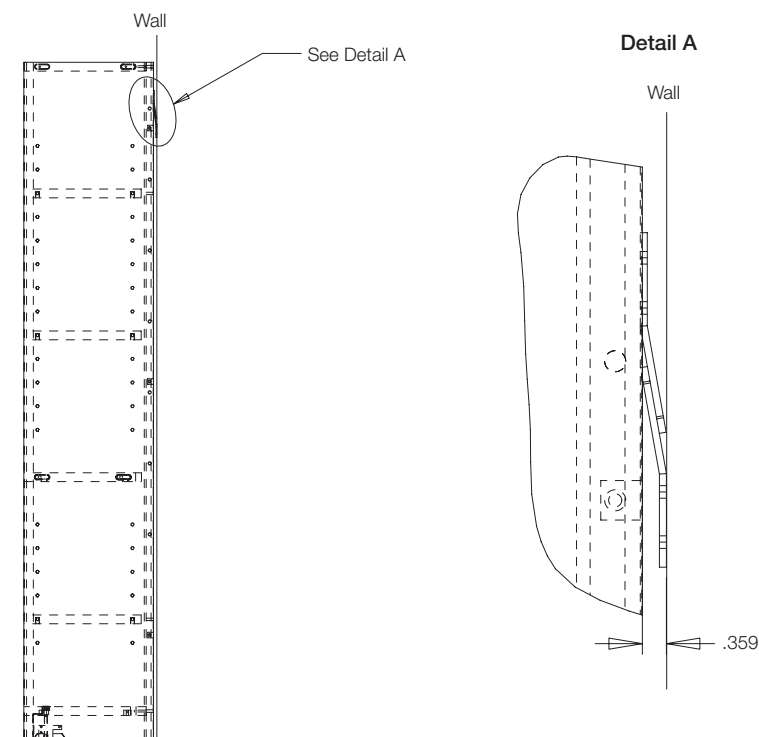

- 1.1. Level all bookcases in installed position. For ganging bookcases align to one another but do not attach.
- 1.2. Mark the center of each bookcase on the wall and install the matching clip in the appropriate location. (Screws are not provided.) (Fig. 1)

Fig 1



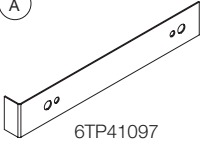

Bookcase Ganging Kit

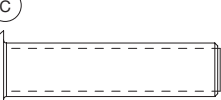
Reference Number: 6TP00436

HARDWARE LIST FOR GANGING 11"D CABINETS		
(A)		(B)
	6TP41097 DRILLING TEMPLATE	
		6TP41094 SCREW, TRUSS HEAD/10-24x5/16"
		(C)
		
		6TP41093 BOLT, BARREL/ 10-24x1-1/4"

Tools Needed

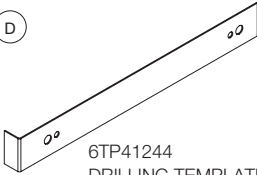
- Drill gun
- Drill bit Ø 1/4"
- Phillips driver bit

HARDWARE LIST FOR GANGING 14"D CABINETS		
(D)		(E)
	6TP41244 DRILLING TEMPLATE	
		6TP41094 SCREW, TRUSS HEAD/10-24x5/16"
		(F)
		
		6TP41093 BOLT, BARREL/ 10-24x1-1/4"

1. Assembly Instructions for Ganging Cabinets

- 1.1. Remove one adjustable shelf below the fixed shelf and the first adjustable shelf below the top of the bookcase. (Fig. 2)
- 1.2. Place the template (A) on the gable where the adjustable shelf was removed, lining up the first and last hole on the template with the pins in the gable. (Fig. 2)
- 1.3. Drill two through holes thru the smaller size holes in the template.
- 1.4. Repeat steps 1.1-to 1.3 for the adjacent cabinet.
- 1.5. Peel off the paper from double sided tape on the back reveal strips. Attach the reveal strips inset 1/32" from the front and rear edges of the bookcase. (see Detail A.)
- 1.6. Secure the cabinet gables using 4 bolt barrels (C) and 4 truss head fasteners (B). (Fig. 3)
- 1.7. Replace the adjustable shelves in the cabinets. (Fig. 4)

Fig 2

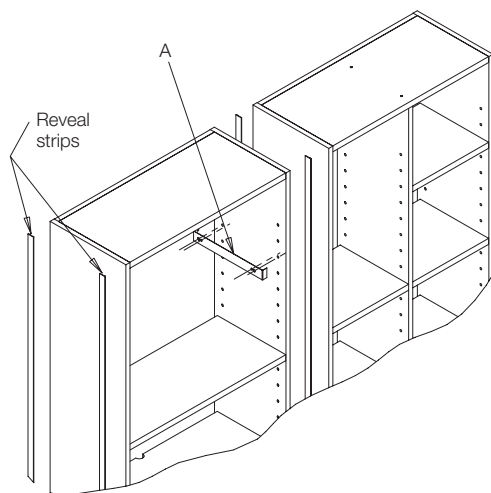

Top View

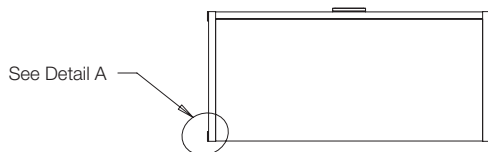
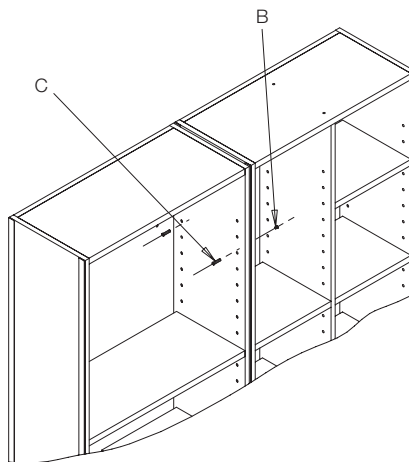

Fig 3



Detail A

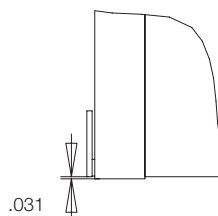
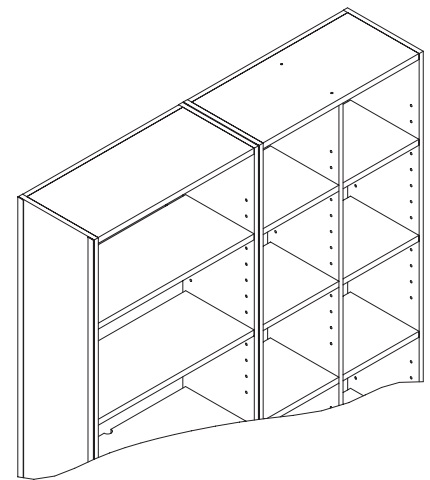
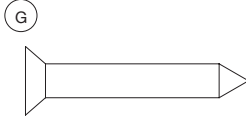



Fig 4



Bookcase Ganging Kit

Reference Number: 6TP00436

HARDWARE LIST FOR STACK-ON CABINETS	
	
<p>2TP40385 SCR,SM FLP #10x1-1/4 TYPE A ZINC</p>	<p>6TR41860 PLUG,PLASTIC\CLEAR,5/8DIA</p>

Tools Needed

- Drill gun
- Drill bit Ø 1/8"
- Phillips driver bit

1. Assembly Instructions for Stack-On Cabinets

- 1.1. Drill through holes concentric with the blind holes in the bottom shelf of the Stack-On Cabinet. (Fig. 5)
- 1.2. Peel off the paper from double sided tape on the back reveal strips. Attach the reveal strips inset 1/32" from the front and rear edges of the bookcase, use "Detail A" on sheet #3 for reference.
- 1.3. Place Stack-On Cabinet on top of the lower bookcase. (Fig. 5)
- 1.4. Use fasteners (G) to secure the cabinets together. (Fig. 5)
- 1.5. Use plastic plugs (H) to cover the blind holes. (Fig. 5)

Fig 5

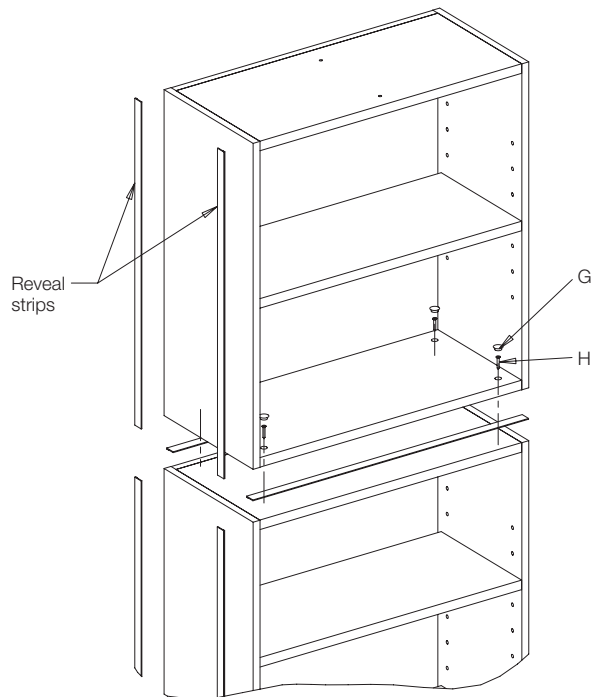
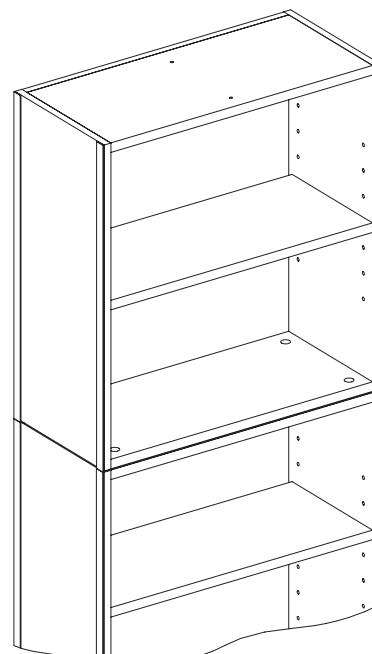



Fig 6



Bookcase Ganging Kit

Reference Number: 6TP00436

HARDWARE LIST FOR CABINET SHOULDER	
(K)	
2TP40385 SCR,SM FLP #10x1-1/4 TYPE A ZINC	

Tools Needed

- Drill gun
- Drill bit Ø 1/8"
- #3 Phillips driver bit

1. Assembly Instructions for Cabinets Shoulder

- 1.1. Remove one adjustable shelf below the fixed shelf and the first adjustable shelf below the top.
- 1.2. Place the template (A) on the gable where the adjustable shelf was removed, lining up the first and last hole on the template with the pins in the gable. (Fig. 7)
- 1.3. Drill two through holes thru the smaller size holes in the template. (Fig. 7)
- 1.4. Peel off the paper from double sided tape on the back reveal strips. Attach the reveal strips inset 1/32" from the front and rear edges of the shoulder, use "Detail A" on sheet #3 for reference.
- 1.5. Assemble the shoulder panel to the bookcase using 4 fasteners (K). (Fig. 8)
- 1.6. Re-place the adjustable shelves in the cabinets. (Fig. 9)

Fig 7

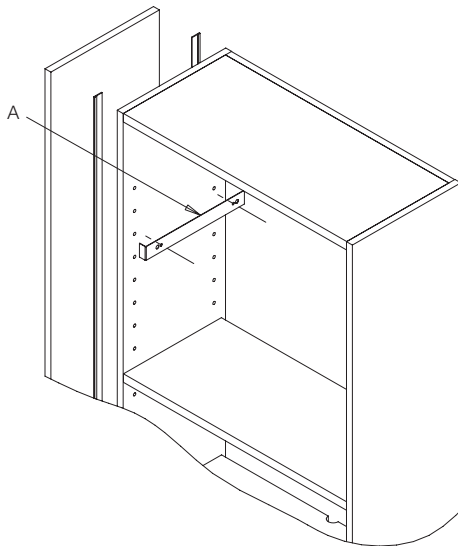

Fig 8

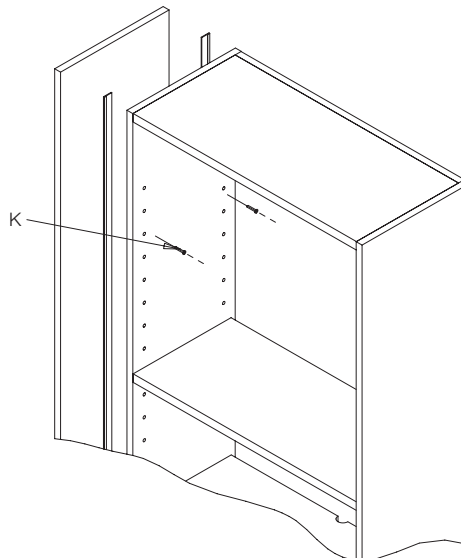
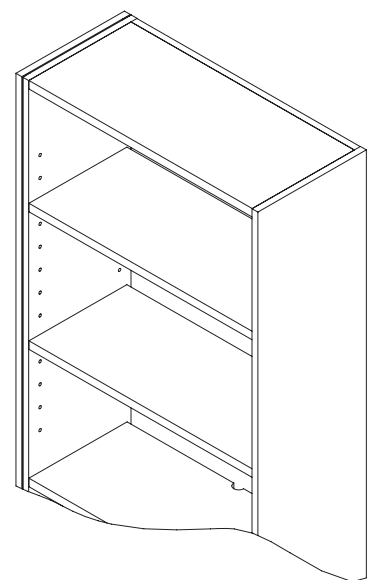

Fig 9



Bookcase Ganging Kit

Reference Number: 6TP00436

HARDWARE LIST FOR GANGING 14"D CABINETS	
<p>6TP41094 SCREW, TRUSS HEAD/10-24x5/16"</p>	<p>6TP41093 BOLT, BARREL/ 10-24x1-1/4"</p>

Tools Needed

- Drill gun
- Drill bit Ø 1/4"
- Phillips driver bit

1. Assembly Instructions for Wall Storage Units Back-to-Back Attachment

Note: All wall storage units must be attached to a wall or back to back to each other. Ganging Kit must be ordered separately for Back-to-Back application use the "Hardware list for ganging 14"D cabinets". See sheet #2.

- 1.1. Level all bookcases in installed position. Align to one another back to back.
- 1.2. Remove top and bottom adjustable shelves.
- 1.3. Drill the backs of both cabinets in 4 places centered on shelf thickness as shown in Fig. 10.
- 1.4. Install bolt (E) and barrel (F).
- 1.5. Replace adjustable shelves.

Fig 10

