

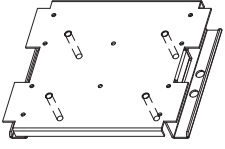

Center Support
 Meeting Tables with 4x4 Leg
 Reference Number: 6tp00465

HARDWARE LIST		
<p>(A)</p>  <p>P/N VARIES MOUNT, CENTER SUPP\2-RAIL</p>	<p>(B)</p>  <p>P/N VARIES MOUNT, CENTER SUPP\4-RAIL</p>	
<p>(C)</p>  <p>P/N VARIES FRAME, CENTER SUPP\2-RAIL</p>	<p>(D)</p>  <p>P/N VARIES FRAME, CENTER SUPP\4- RAIL</p>	<p>(E)</p>  <p>800072 WELDNUT, HEX 1/2-13 UNC 2B</p>

Center support
2 Rails

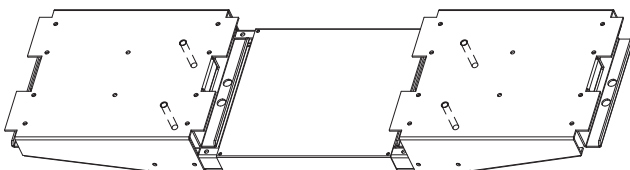
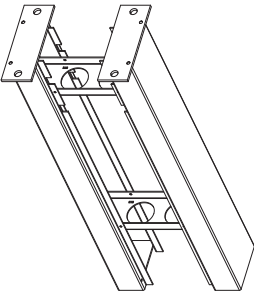
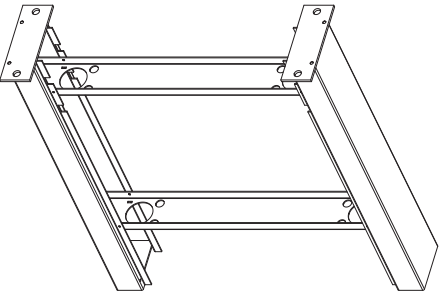

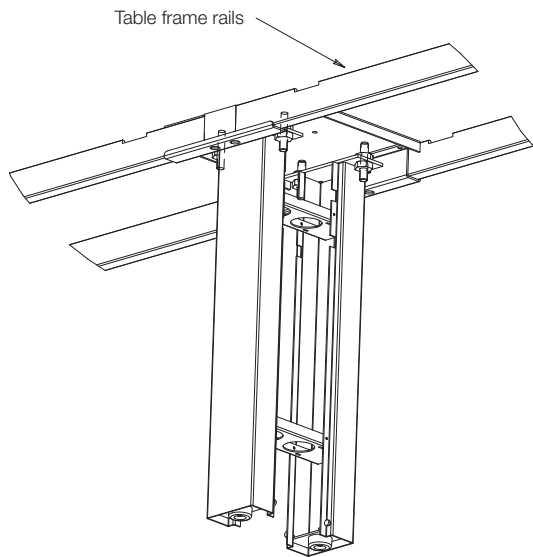
Center support
4 Rails

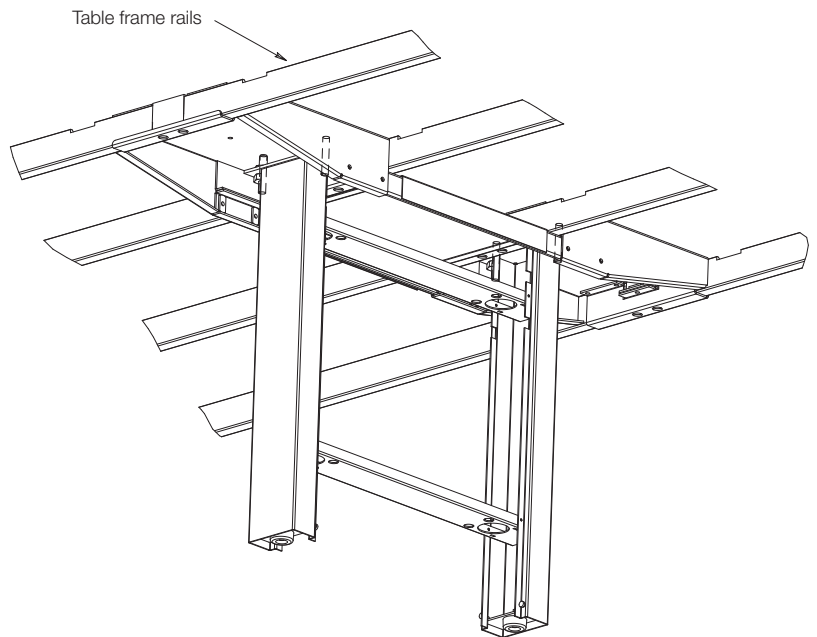

Center Support

Meeting Tables with 4x4 Leg

Reference Number: 6tp00465

Tools Needed

- Allen keys
- Drill gun
- Phillips driver bit
- 1/2" Open wrench
- 1/2" Socket

1. Assembly instructions

1.1 Frame and mount assembly

- 1.1.1. Place the Center Support frame (C) or (D) in upright position. (Fig. 1) (Fig. 2)
- 1.1.2. Assemble one weldnut (E) to each of the threaded rods welded to the mount (A) or (B). (Fig. 1) (Fig. 2)
- 1.1.3. Place the mount (A) or (B) on top of the frame, fitting the threaded rods through the holes in the frame. (Fig. 1) (Fig. 2)
- 1.1.4. Using the other four weldnuts (E) secure the mount (A) or (B) to the frame (C) or (D) assembly. (Fig. 1) (Fig. 2)

Note:

The aluminum extrusions and connectors are part of the table frame assembly.
 Table height adjustment is affected by adjusting the upper and lower hex nuts to raise and lower the table rails to suit.

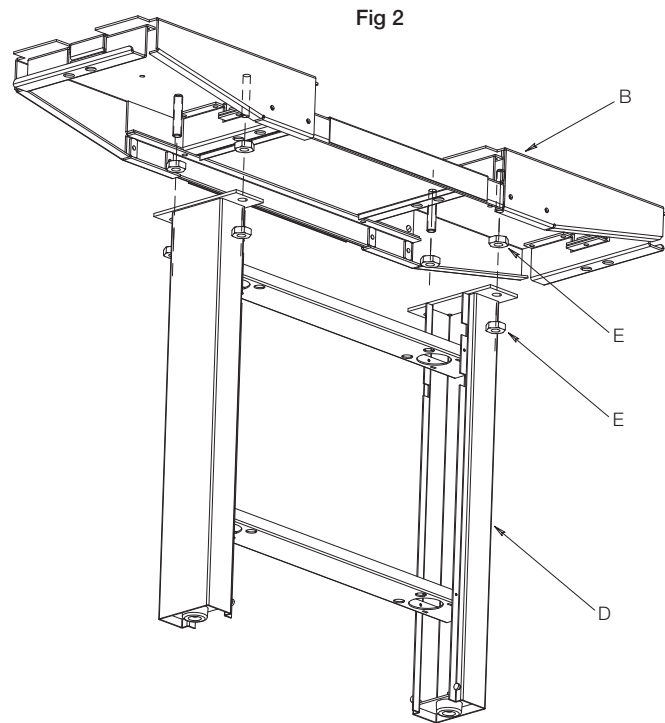
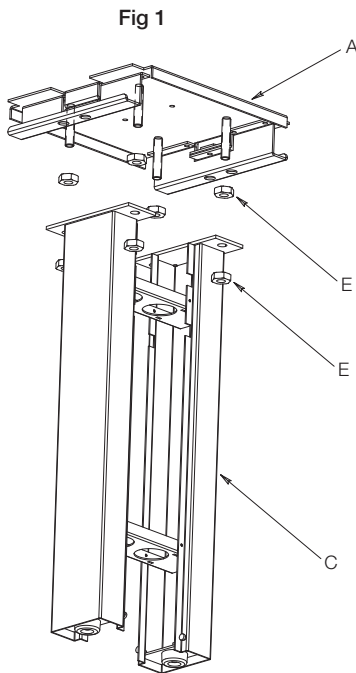

Front view : Center support / 2-Rail

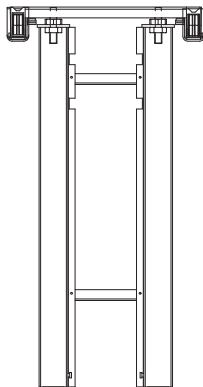

Front view : Center support / 4-Rail

