

9/5/2012

# Sapper™ Monitor Arm Collection Single Monitor Arm Kit Installation Instructions

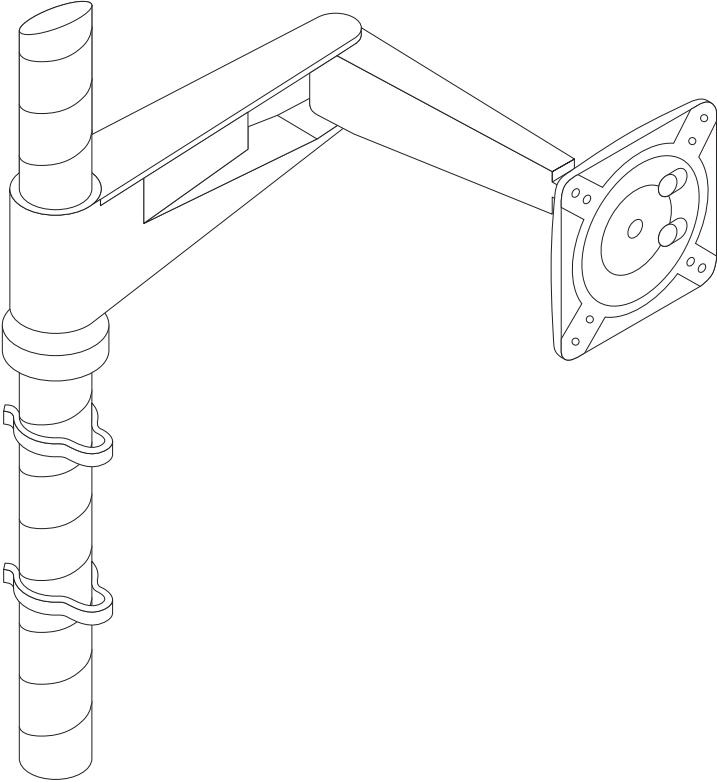

## Step 1: Attach Mount to Work Surface, Slat Wall or Wall

### Two-Piece Table Clamp, Heavy Duty Table Clamp and Deep Table Clamp Mounts

#### Tools Needed

Allen wrenches (in inches)

- Clamp lower to upper jaw – 5/32" (B)
- Clamp to mast – 5/16" (H)
- Clamp compression screws – 1/4" (A)

#### For installation on a work surface positioned against a wall or panel:

1. Remove clamp lower jaw (C) by removing both clamping screws (A) and both lower jaw mounting screws (B).
2. Assemble mast upper jaw (E) to clamp upper jaw (G) by inserting the pin (F) on clamp (G) into hole in bottom of mast (E). Secure mast (E) to clamp (G) with screw (H). Tighten securely. Slide upper jaw (G) down along edge of desk surface.
3. Beneath work surface, replace lower jaw (C), by reinstalling (2) mounting screws (B), (2) clamping screws (A) and (2) pressure discs (D). Tighten both clamping screws (A) with pressure discs (D) in place on top of clamping screws (A). Do not over-tighten as this may damage the table surface.

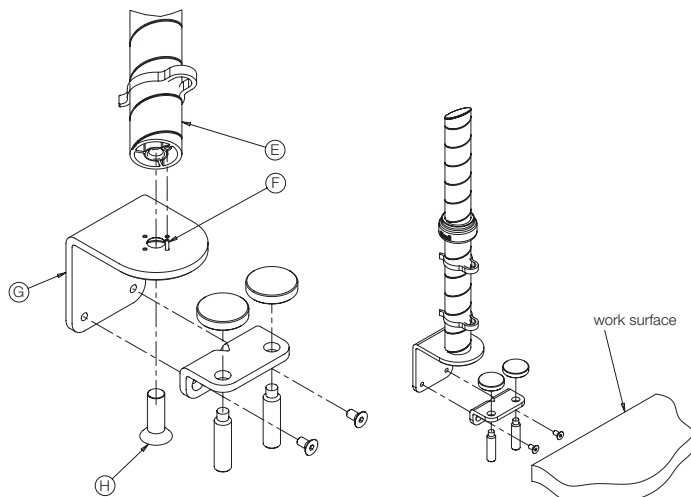
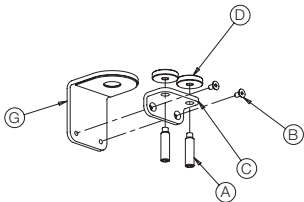

#### For installation on open edge of work surface:

1. Assemble mast (E) to clamp (G), by inserting the pin (F) on clamp (G) into hole in bottom of mast (E). Secure mast (E) to clamp (G) with screw (H). Tighten securely.
2. Slide table clamp (G) onto edge of desk surface. With pressure discs (D) in place on top of clamping screws (A), tighten both clamp screws (A). Do not over-tighten as this may damage the table surface. If clamp opening needs adjustment to accommodate thicker or thinner desk top, follow instructions to the left.

*Note: The Deep Table Clamp (Fig. 1) is one piece and can only be mounted on open edge of worksurface as described above.*

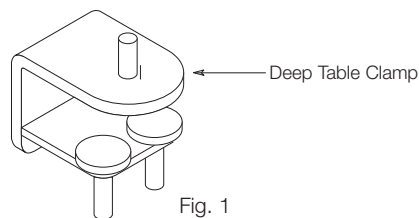
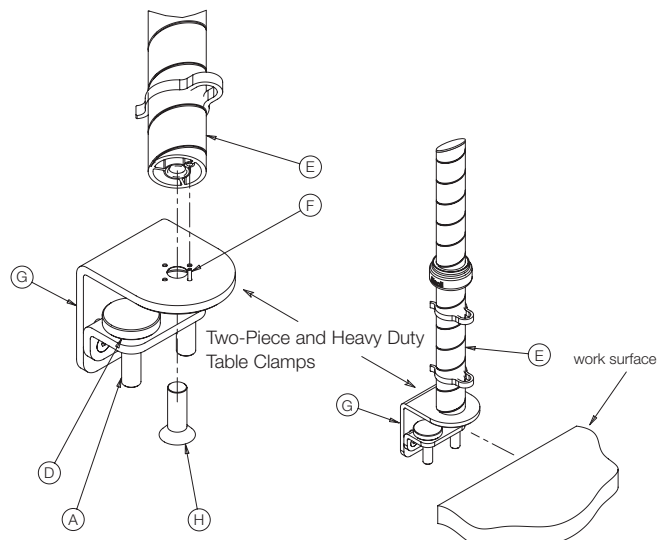

Fig. 1



## Grommet Mount

### Tools Needed

- 3/4" open end wrench (C)

1. Choose the orientation of grommet mount plate (A) on the work surface. Remove grommet cover and any moveable grommet liner.
2. Place the grommet mount plate (A) over the grommet hole, with 1/2" hole for the threaded connection stud (F) inside the grommet hole. Adjust placement of the grommet mount plate (A) so it equally overhangs the grommet hole.
3. Thread the threaded connection stud (F) into the bottom of the mast (E) using all available threads. Pass the threaded connection stud (F) through the 1/2" hole in grommet mount plate (A) and through the grommet hole.
4. Beneath the desk, slide the mounting bar (B) and washer (D) onto the threaded connection stud (F). Thread nut (C) onto threaded connection stud (F). Orient the mast with the top of the slope (H) facing the user. Tighten nut (C) using a wrench. Do not over-tighten as this may damage the table surface.

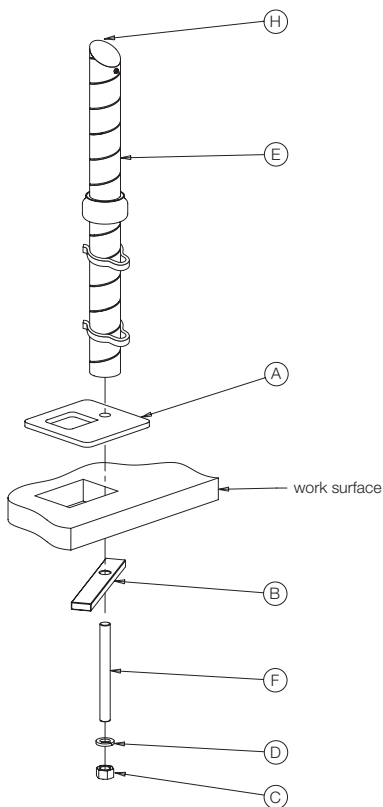

## Fixed Table Mount

### Tools Needed

- 3/4" open end wrench (C)
- Drill

1. Establish desired mounting location. Drill a 17/32" diameter hole, through the table surface/desk top. Assemble disc (A), lock washer (B) and nut (C) onto stud (D).
2. From beneath the desk, push top of stud (D) up through hole. Slide second disc (A) over stud (D). Thread mast (E) onto stud using all available threads in mast (E).
3. Orient the mast (E) with the top of the slope (F) facing the user. Tighten nut (C). Do not over-tighten as this may damage the table surface.

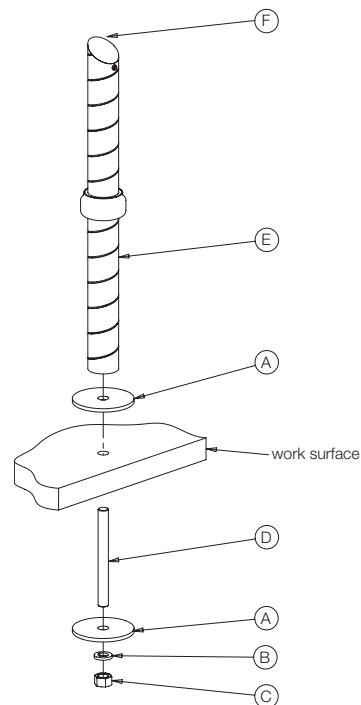

## Step 1: Attach Mount to Work Surface, Slat Wall or Wall

### Crinion Open Table Center Channel Mount

#### Tools Needed

Allen Wrenches (in inches and mm's)

- Crinion Open Table (COT) Center Channel Mount to Mast – 5/16" (E)
- Crinion Open Table (COT) Center Channel Mount to Flex-Link Nuts – (5mm) (C)

1. Assemble mast (D) to COT Center Channel Mount (B) by inserting the pin (F) on the COT Center Channel Mount (B) into the hole in the bottom of the mast (D). Secure mast (D) to COT Center Channel Mount (B) with screw (E). Tighten securely.
2. Insert (2) flex-link nuts (A) into top center channel of COT by pushing one side (long edge) down into the channel until the following edge/side drops into the channel (see illustration).
3. Slide flex-link nuts (A) to desired mounting location. Assemble COT Center Channel Mount (B) to flex-link nuts (A) with screws (C), tighten securely.

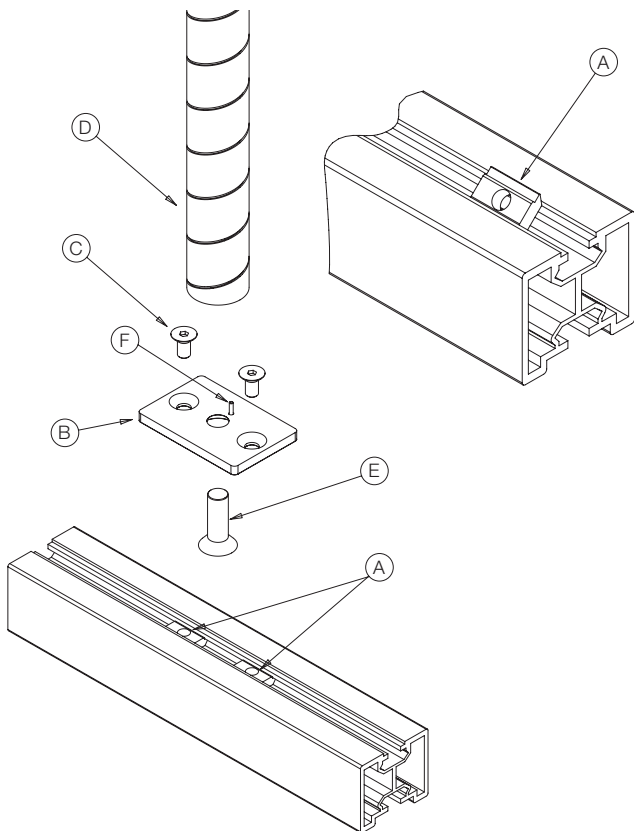

### Dividends Horizon Benching Mount

#### Tools Needed

Allen wrenches (in inches)

- Mount to mast - 5/16" (H)
- Compression Screws - 1/4" (A)

1. Remove both Dividends Horizon Benching Mount lower jaws (C) by removing both clamping screws (A) and both lower jaw mounting screws (B).
2. Assemble mast (E) to Dividends Horizon Benching Mount (G), by inserting the pin (F) on Dividends Horizon Benching Mount (G) into hole in bottom of mast (E). Secure mast (E) to Dividends Horizon Benching Mount (G) with screw (H). Tighten securely. Slide Dividends Horizon Benching Mount (G) down along edge of desk surface.
3. Beneath work surface, replace both lower jaws (C) by reinstalling (2) mounting screws (B), (2) clamping screws (A) and (2) pressure discs (D). Tighten both clamping screws (A) with pressure discs (D) in place on top of clamping screws (A). Do not over-tighten as this may damage the table surface.

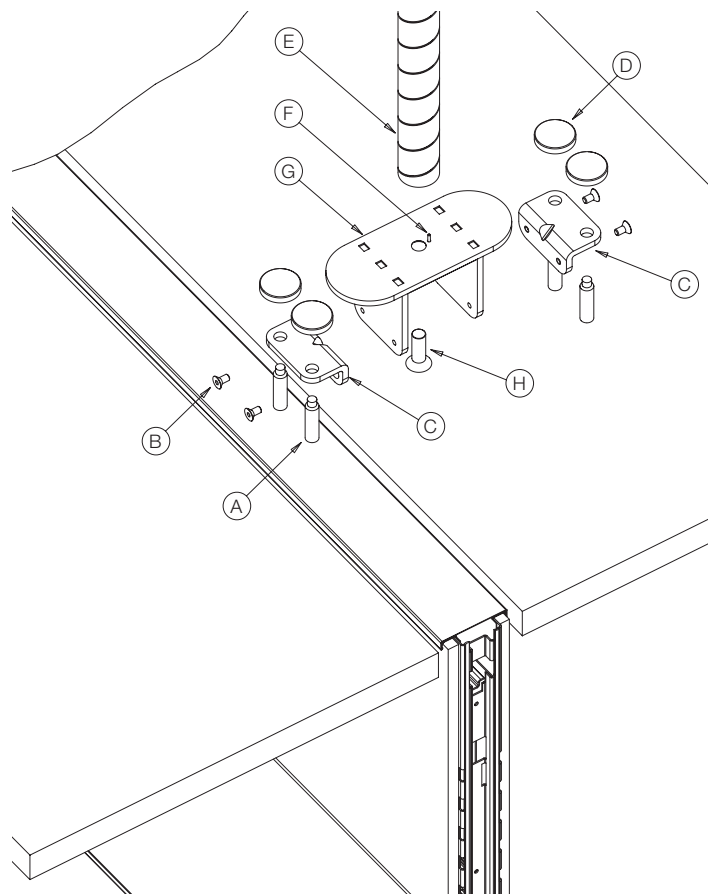

## Antenna Table Center Beam Center Mount

### Tools Needed

Allen wrenches (in inches and mm's)

- Antenna Table Center Beam Center Mount to Mast – 5/16" (E)
- Antenna Table Center Beam Center Mount to Flex-Link Nuts – (5mm) (C)

1. Assemble mast (D) to Antenna Table Center Beam Center Mount (B), by inserting the pin (F) on the Antenna Table Center Beam Mount (B) into the hole in the bottom of the mast (D). Secure mast (D) to Antenna Table Center Beam Center Mount (B) with screw (E). Tighten securely.
2. Insert (2) flex-link nuts (A) into top center beam of Antenna Big Table by pushing one side (long edge) down into the beam until the following edge/side drops into the channel (see illustration).
3. Slide flex-link nuts (A) to desired mounting location. Assemble Antenna Table Center Beam Center Mount (B) to flex-link nuts (A) with screws (C). Tighten securely.

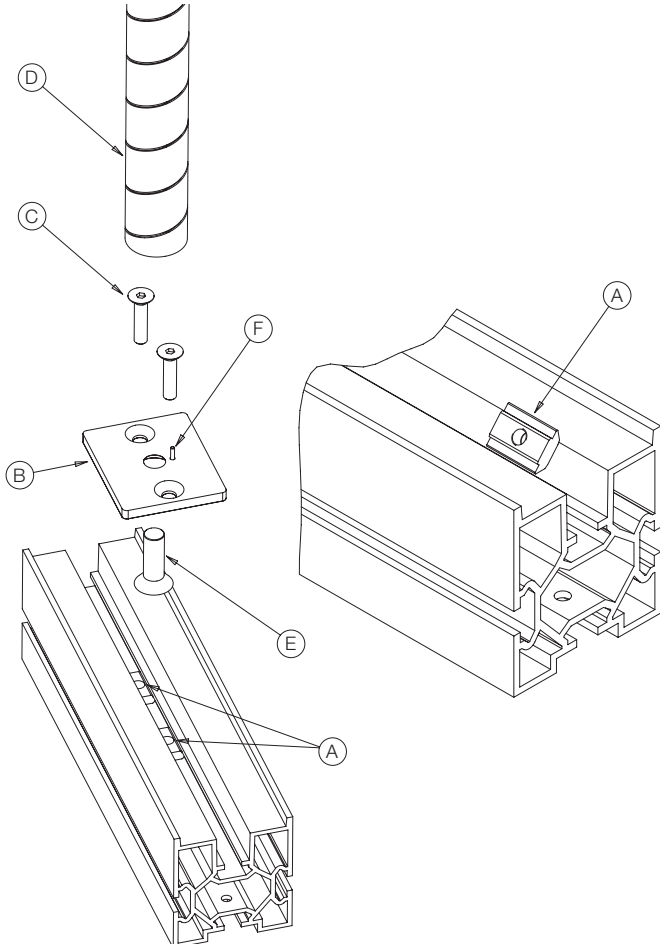

## Antenna Table Center Beam Side Mount

### Tools Needed

Allen wrenches (in inches and mm's)

- Antenna Table Center Beam Side Mount to Mast – 1/4" (E)
- Antenna Table Center Beam Side Mount to Flex-Link Nuts – Phillips Screwdriver (C)

1. Assemble mast (D) to Antenna Table Center Beam Side Mount (B), by inserting the curved ribs (F) of Center Beam Side Mount (B) into voids of mast (D). Secure mast to Antenna Table Center Beam Side Mount (B) with screw (E). Tighten securely.
2. Insert (2) flex-link nuts (A) into side channel of beam of Antenna Big Table by pushing one side (long edge) down into the channel until the following edge/side drops into the channel (see illustration).
3. Slide flex-link nuts (A) to desired mounting location. Assemble Antenna Table Center Beam Side Mount (B) by dropping bracket on side flange of beam (G) and securing with screws (C). Tighten securely.

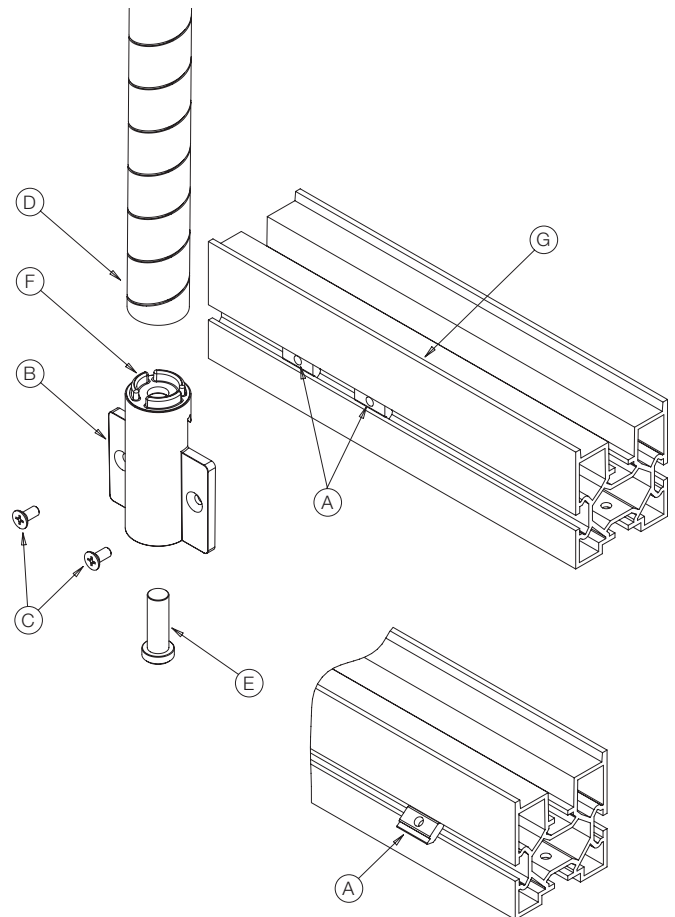

## Slat Wall Mast Mount

### Tools Needed

Allen wrenches (in inches)

- Slat wall Mounted Mast Bracket to Mast - 5/16" (K)
- Slat wall to strap - 5/32" (C)
- Slat wall anti-dislodgement - 1/16" (G)

1. Insert the mounting strap (A) into desired slatwall slot, with holes closer to top edge. Hang slat wall bracket (B) in desired slot aligning strap (A) holes with appropriate hole in bracket (B).
2. Install and tighten (2) screws (C). Hang mast mount bracket (D) on slat wall bracket (B), by engaging hanger strap (E) with top hook of hanger casting (F). Seat mast mount bracket (D) down, fully onto hanger casting (F).
3. Secure bracket (D) to casting (F), with screw (G). Insert mast (H) into bracket (D) positioning mast (H) with top of slope (J) facing the user. Seat mast (H) fully into bracket (D) and secure with screw (K).

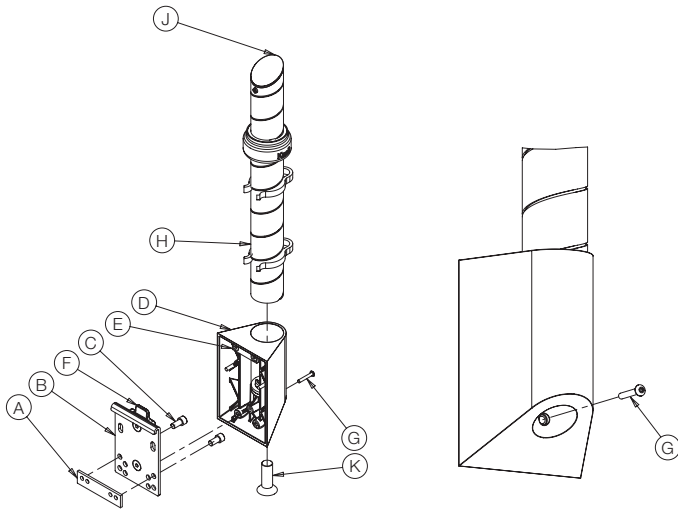

## Wall Mast Mount (for Architectural Walls Only)

### Tools Needed

Allen wrenches (in inches)

- Wall Mounted Mast Bracket to Mast - 5/16" (K)
- Wall anti-dislodgement - 1/16" (G)

1. Mark the locations for four mounting screws customer supplied (A) on the wall at the desired location using the outer holes on the mounting plate (B) as a template, making sure the bracket is level. Drill pilot holes in each location.
2. Pass the mounting screws through the outer holes on the mounting plate (B) and screw them into the wall.
3. Hang arm mount bracket (D) on wall mount plate (B) by engaging hanger strap (E) with top hook of hanger casting (F). Seat mast mount bracket (D) down fully onto hanger casting (F).
4. Secure bracket (D) to casting (F) with screw (G).
5. Insert mast (H) into bracket (D), positioning mast (H) with top of slope (J) facing the user. Seat mast (H) fully into bracket (D) and secure with screw (K).

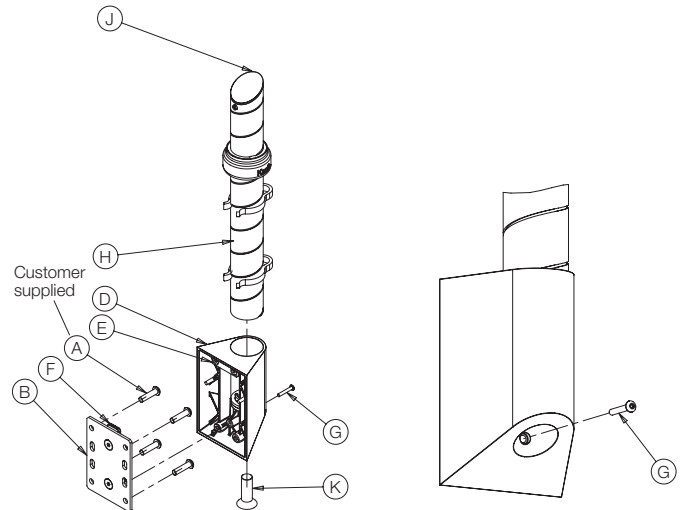

## Step 2: Attach Monitor Plate (Movement Joint Included) to the Monitors or Television

### Tools Needed

- Screwdriver or Allen wrench

1. Remove monitor base and hardware from the monitor. Retain all hardware.
2. Place movement joint (A) against back of monitor or television, with Knoll logo toward top of monitor and attach the VESA plate (B) using appropriate hardware. VESA plate can accommodate 75 mm or 100 mm hole patterns.
3. Attach movement joint (A) to arm (E) by connecting them together, then inserting fast release pin (D).

*Note: Movement joint can hold up to 20 lbs.*

*Note: Check VESA compliancy and hole pattern on monitor or television as Knoll monitor solutions are designed to work with VESA compliant monitors only. The Knoll VESA plate can accommodate 75mm or 100mm hole patterns. Knoll movement joints do not ship with screws and are designed to accept an M4 or M5 screw; length is dependent on the specific monitor or television and screw should be tested prior to installation to ensure correct length; Knoll is not responsible for use of*

*incorrect screws. If monitor has recessed VESA mounting surface, spacers (C) may be required between movement joint (A) and monitor. Spacers must be requested through Knoll Customer Service.*

*A VESA plate adaptor may be necessary for larger monitors and televisions and can be ordered separately in the sizes of 100 mm x 200mm (M5 screws), 200mm x 200mm (M6 screws), 300mm x 300mm (M8 screws) and 400mm x 400mm/400mm x 600mm (M8 screws). Adaptors ship with separate installation instructions and may require spacers. Knoll VESA plate adaptors ship with screws to attach the adaptor to the Knoll VESA plate but do not ship with screws to attach the adaptor to the monitor or television (see screw sizes listed above, English size equivalents may be needed instead); screw length is dependent on the specific monitor or television and screw should be tested prior to installation to ensure correct length, Knoll is not responsible for use of incorrect screws.*

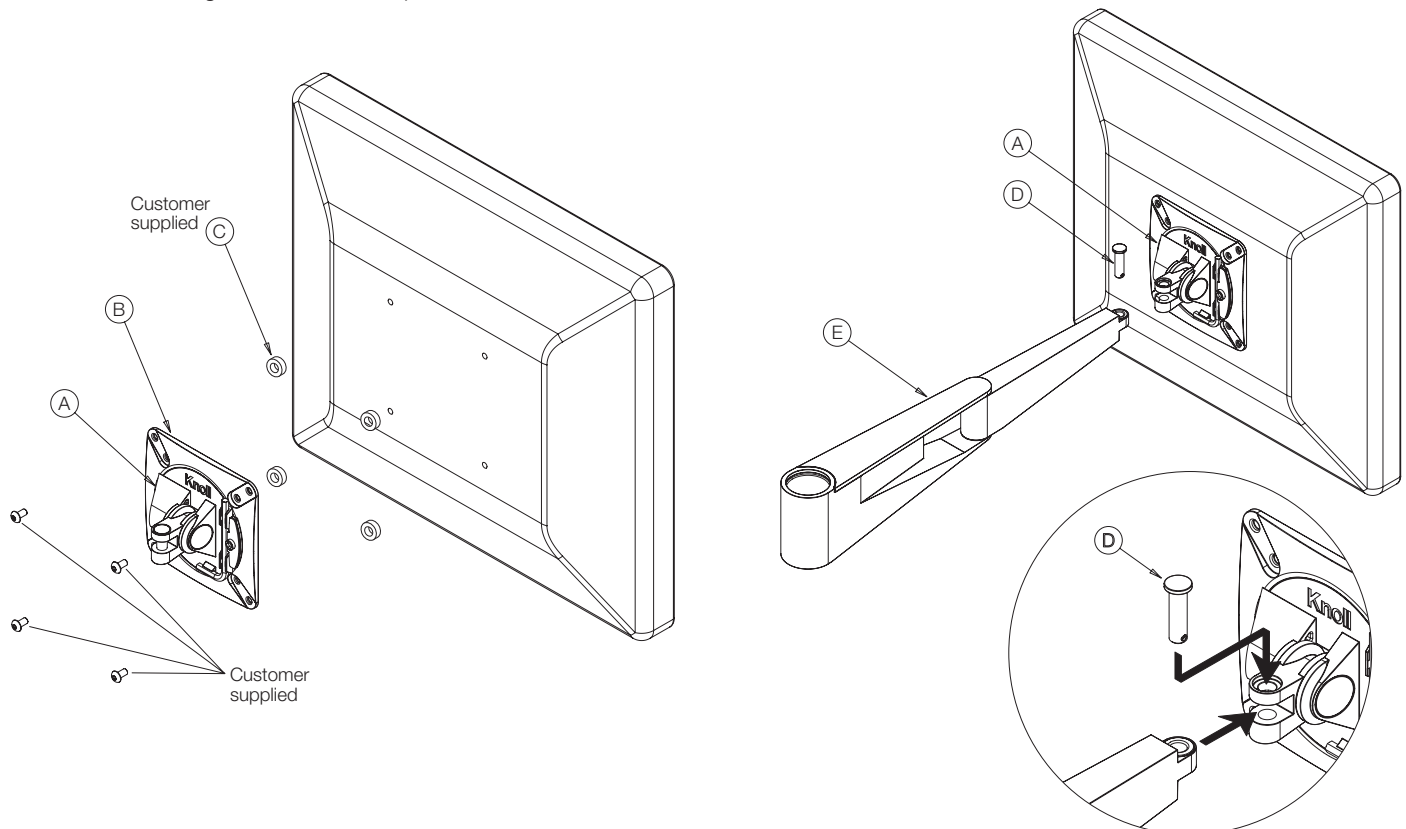

## Step 3: Attach Arm with Monitor to Mast

### Tools Needed

Allen wrenches (in inches)

- Mast anti-dislodgement – 5/64" (D)

1. Remove the mast top cap (E) and stop screw (D).
2. Rotate the adjustment knob (A) to the desired height. (Note: Knoll logo on adjustment knob should be face up).
3. Slide the arm and monitor assembly (C) onto and down the mast (B) until it rests securely on the adjustment knob (A). With the arm in place, reinstall the stop screw (D) and top cap (E).

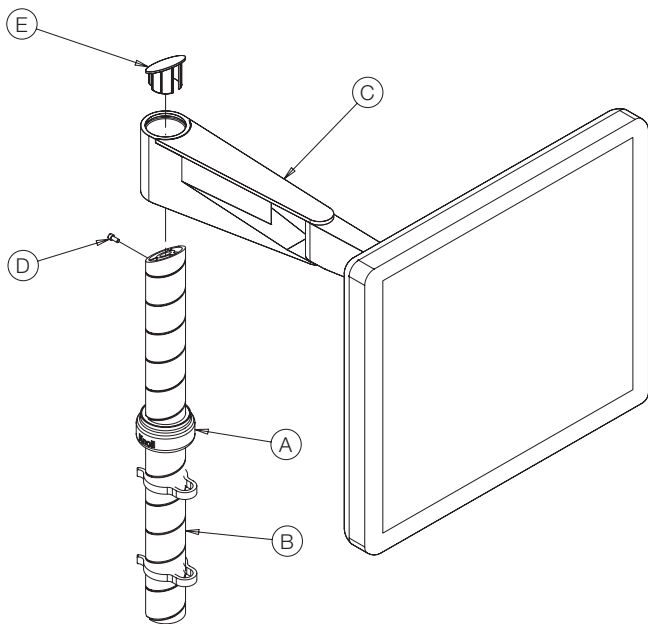



## Features: Cable Management and Fast Release

### Cable Management Gates and Clip(s)

To manage cables under the arm, open inboard gates (A) and (B), by slightly moving gate up to overcome the snap detent. Feed wires into the hollow under both arms. Snap both gates closed.

Manage cables down mast (C) and install cables management clips (D) by snapping clip (D) over cables and onto mast (C). Please note there will be one clip for 8" masts and two clips for all masts 12" and longer.

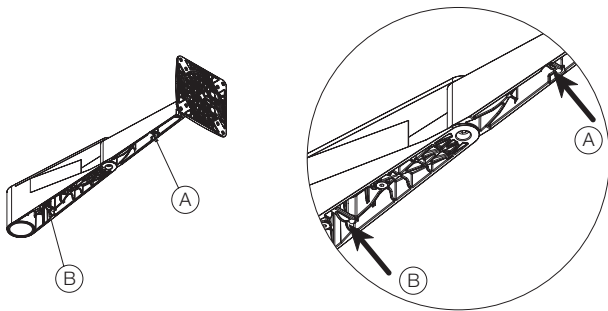

Gates

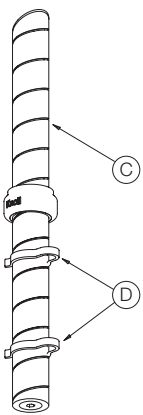

Clips

### Fast Release

1. Fast release functionality allows rapid removal of monitor and movement joint. Remove the fast release pin (A) from the arm assembly (B), disconnecting the movement joint (C).
2. To reinstall, position movement joint on monitor arm and insert fast release pin (A). When fully seated, pin should be flush.

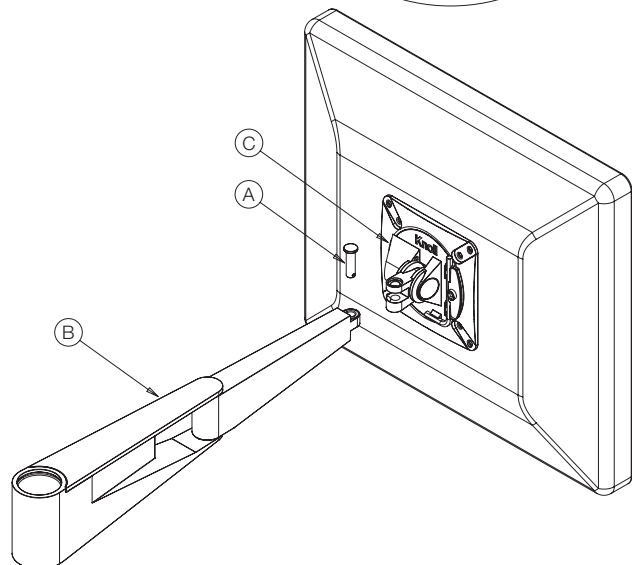
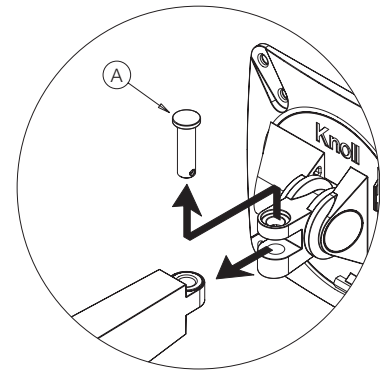

# Features: Friction Adjustment and Anti-Dislodgement

## Tilt and Rotation Friction Adjustments

### Tools Needed

Allen wrenches (in inches)

- Tilt friction – 3/16" (Included on Monitor Plate)
- Rotation friction – 3/16" (C) (Included on Monitor Plate)

### Tilt friction:

To increase friction, insert Allen wrench (included on each monitor plate) (A) into screw (B) and turn clockwise. To reduce tilt friction, turn screw (B) counterclockwise. Adjust in very small increments.

### Rotation friction:

To increase friction, insert Allen wrench (A) (included on each monitor plate) into screw (C) and turn clockwise. Adjust in very small increments.

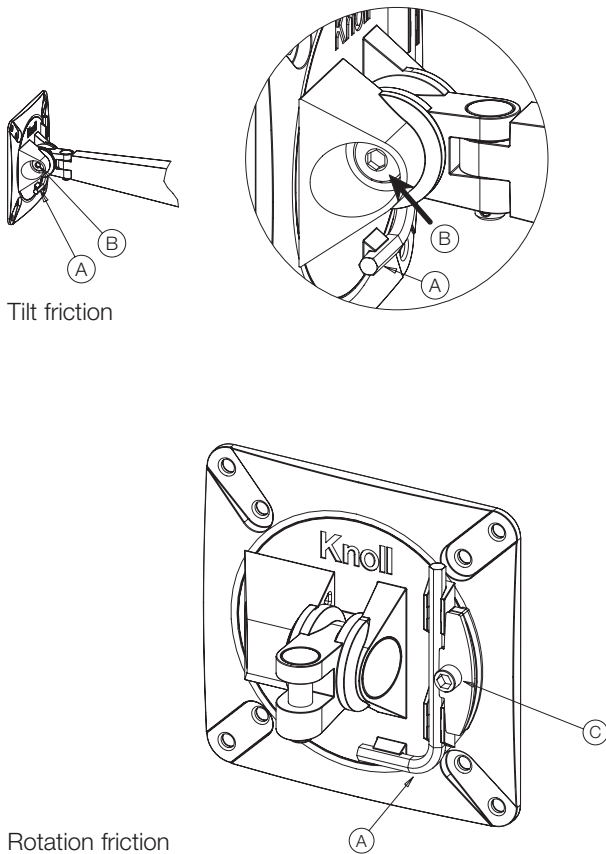

## Anti-Dislodgement and Theft Deterrence

### Tools Needed

Allen wrenches (in inches)

- Anti-theft – 1/16" (A)

1. Sapper monitor arms have anti-theft features. A small set screw (A) resides inside the lower end of the fast release pin (B). To activate anti-theft feature, use a 1/16" Allen wrench and back set screw (A) partially out of fast release pin (B). This prevents fast release function.
2. Also, the stop screw (C) at the top of the mast (D) prevents monitor arm from being removed.

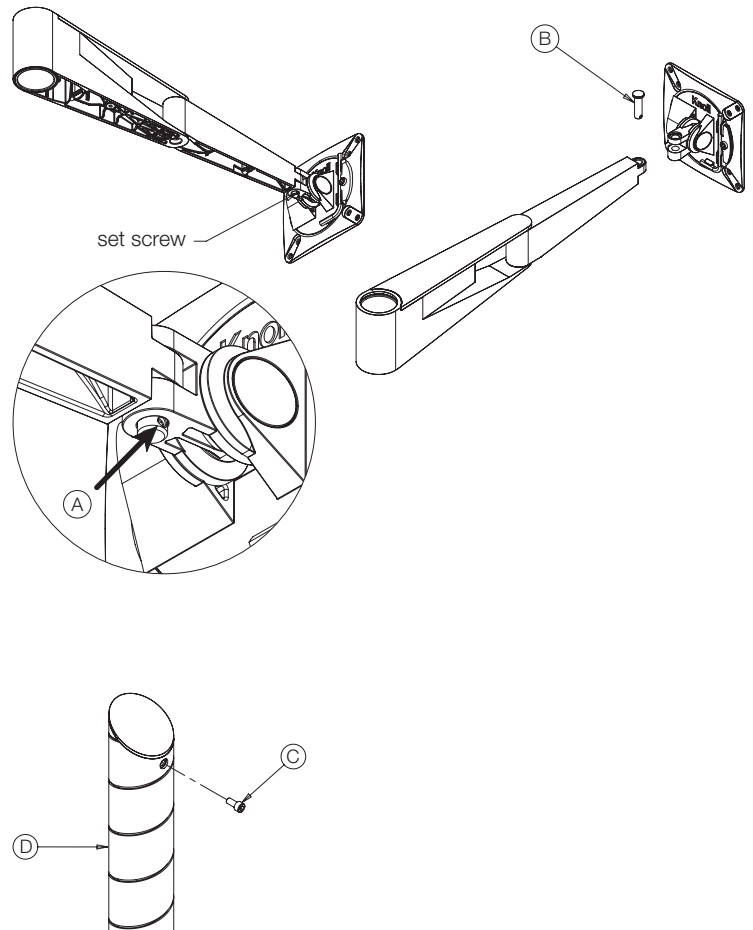

**Knoll**