

Dividends Horizon® 120 Post

1. Install bottom connectors to Post in bottom holes only.

A. Orient legs in downward position on one side. These will connect to existing panel.

B. All other sides should be oriented in upward position (Fig. 1)

2. Assembly Post to Frame

A. Hook post to frame using cactus. Tighten using 120 post connector to (Fig. 2)

B. Using 120 post connector connect additional panels as required.

Note: Several parts will be discarded when connecting Dividends 120

Fig. 1

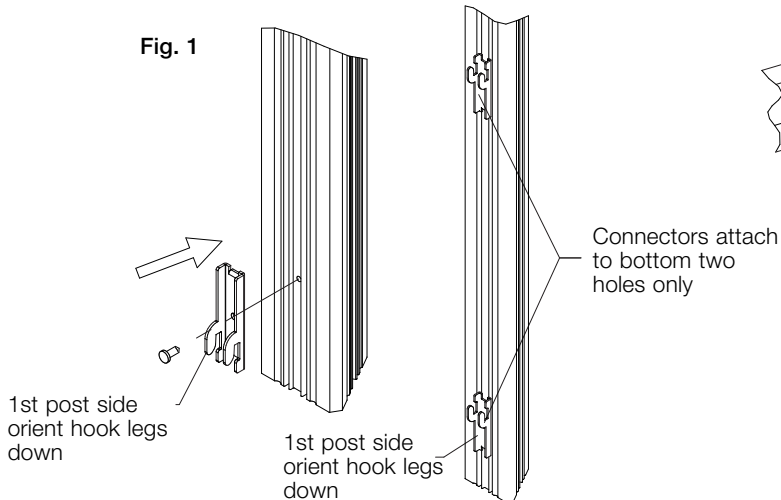
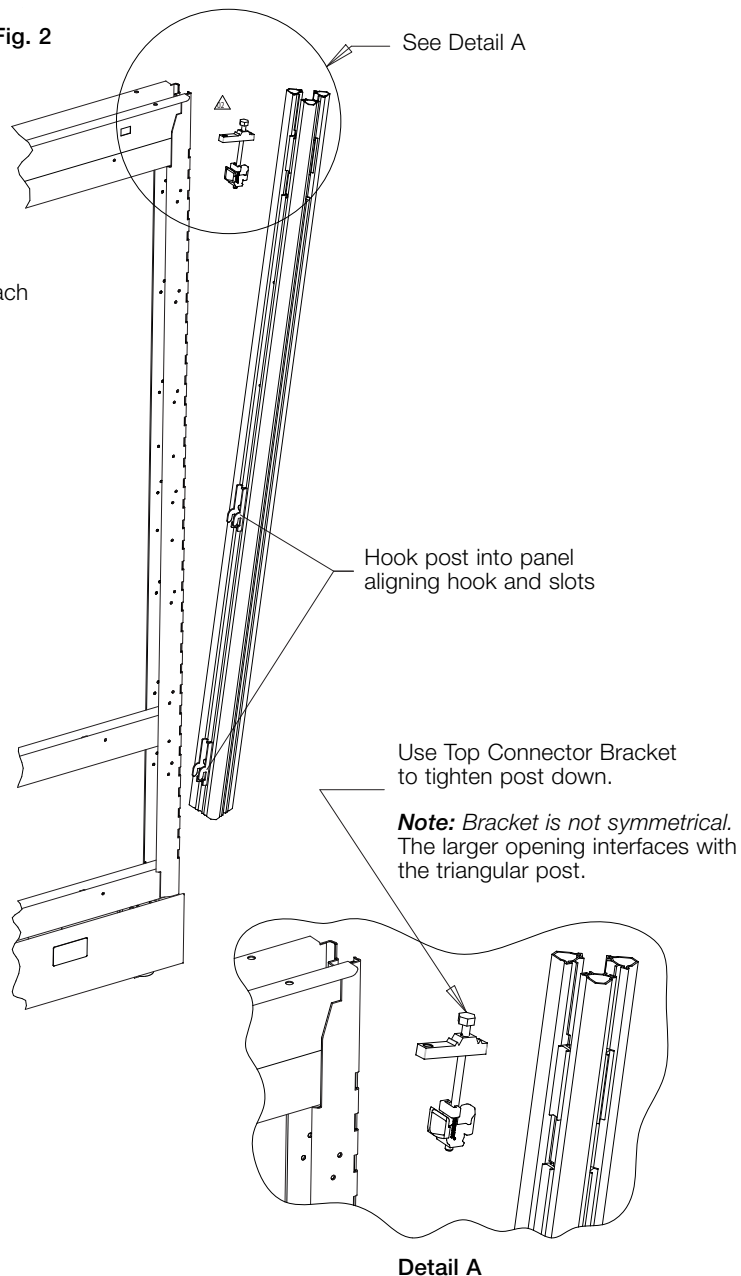
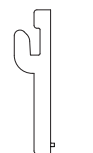
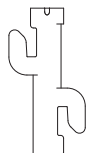

Fig. 2



Note: Use 120 Connecting Hardware discarding Standard Connecting Hardware



Dividends Standard Connectors Square Post

Dividends 120 Connectors Triangle Post

DISASSEMBLY FOR RECYCLING

Materials Identification and Segregation:

Where possible plastic components are marked with ASTM recycling codes. Use these codes to identify material type for recycling. Non-marked components should

be treated as mixed plastic. Ferrous metals can be identified using a small magnet for recycling. Non-ferrous metals should be separated and recycled separately.

To disassemble product, reverse the above installation steps.