

Dividends Horizon® Top Way Knockout Covers

1. Remove vertical stile knockout. (Fig. 1)
2. Install top way knockout covers. (Fig. 2)
3. Make sure that the cover is seated on top of the horizontal rail. (Fig. 3)

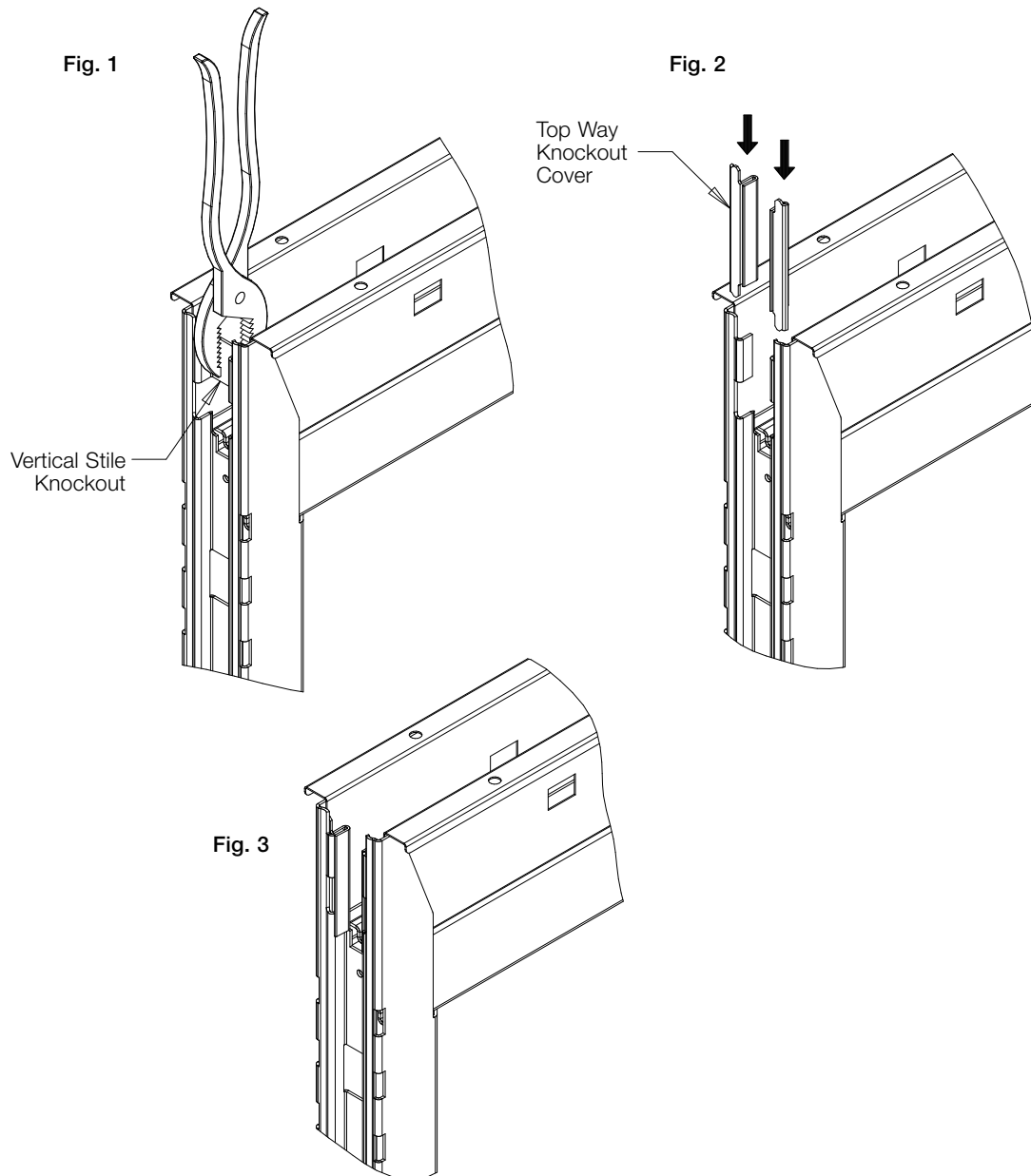

DISASSEMBLY FOR RECYCLING

Materials Identification and Segregation:

Where possible plastic components are marked with ASTM recycling codes. Use these codes to identify material type for recycling. Non-marked components should

be treated as mixed plastic. Ferrous metals can be identified using a small magnet for recycling. Non-ferrous metals should be separated and recycled separately.

To disassemble product, reverse the above installation steps.