

9/5/2012

Sapper XYZ™ Monitor Arm Installation Instructions

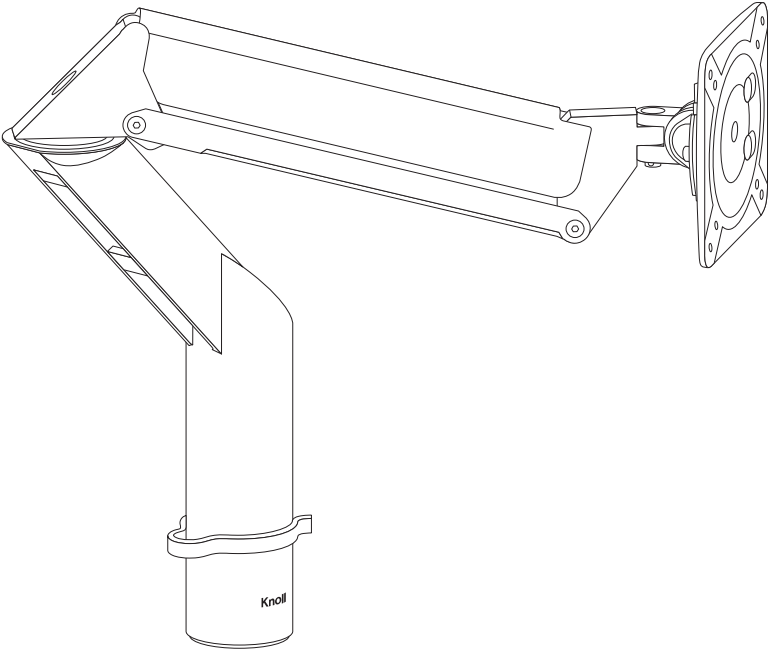

Step 1: Attach Mount to Work Surface

Two-Piece Table Clamp and Deep Table Clamp

Tools Needed

Allen wrenches (in inches):

- Clamp lower to upper jaw – 5/32" (B)
- Clamp to mast – 5/16" (H)
- Clamp compression screws – 1/4" (A)

For installation on a work surface positioned against a wall or panel:

1. Remove clamp lower jaw (C), by removing both clamping screws (A) and both lower jaw mounting screws (B).
2. Slide upper jaw (E) down along edge of desk surface.
3. Beneath work surface, replace lower jaw (C), by reinstalling (2) mounting screws (B), (2) clamping screws (A) and (2) pressure discs (D). Tighten both clamping screws (A) with pressure discs (D) in place on top of clamping screws (A). Do not over-tighten as this may damage the table surface.

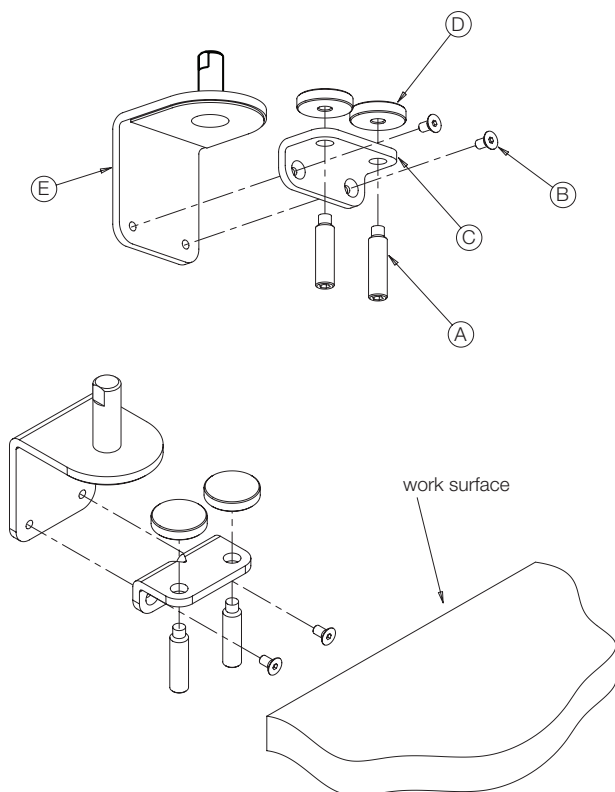

For installation on open edge of work surface:

1. Slide table clamp (F) onto edge of desk surface. With pressure discs (D) in place on top of clamping screws (A), tighten both clamping screws (A). Do not over-tighten as this may damage the table surface. If clamp opening needs adjustment to accommodate thicker or thinner desk top, follow instructions to the left.

Note: The Deep Table Clamp (Fig. 1) is one piece and can only be mounted on open edge of worksurface as described above.

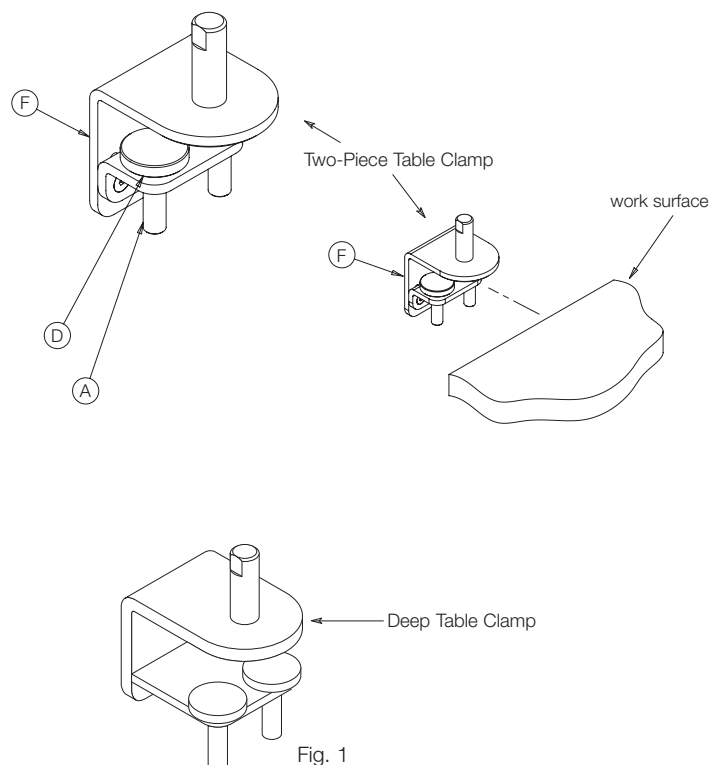

Fig. 1

Grommet Mount

Tools Needed

- 3/4" open end wrench

1. Choose the orientation of grommet mount plate (A) on the work surface. Remove grommet cover and any moveable grommet liner.
2. Place the grommet mount plate (A) over the grommet hole, with 1/2" hole for the threaded connection stud (F) inside the grommet hole. Adjust placement of the grommet mount plate (A) so it equally overhangs the grommet hole.
3. Thread the threaded connection stud (F), into the bottom of the stem (E), using all available threads. Pass the threaded connection stud (F), through the 1/2" hole, in grommet mount plate (A) and thru the grommet hole.
4. Beneath the desk, slide the mounting bar (B) and washer (D) onto the threaded connection stud (F). Thread nut (C) onto threaded connection stud (F). Tighten nut (C) using a wrench. Do not over-tighten as this may damage the table surface.

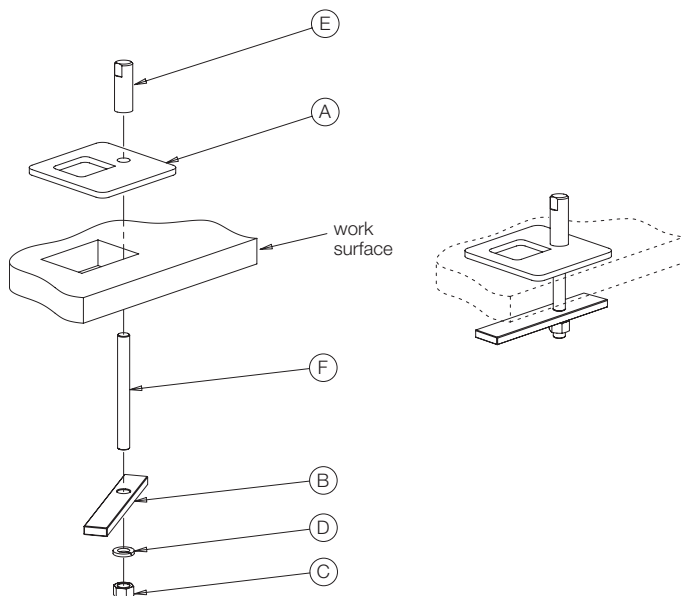

Fixed Table Mount

Tools Needed

- 3/4" open end wrench
- Drill (17/32")

1. Establish desired mounting location. Drill a 17/32" diameter hole through the table surface/desk top. Assemble disc (A) and lock washer (B) and nut (C) onto stud (D).
2. From beneath the desk, push top of stud (D) up through hole. Slide second disc (A) over stud (D). Thread mast (E) onto stud (D) using all available threads in stem.
3. Tighten nut (C). Do not over-tighten as this may damage the table surface.

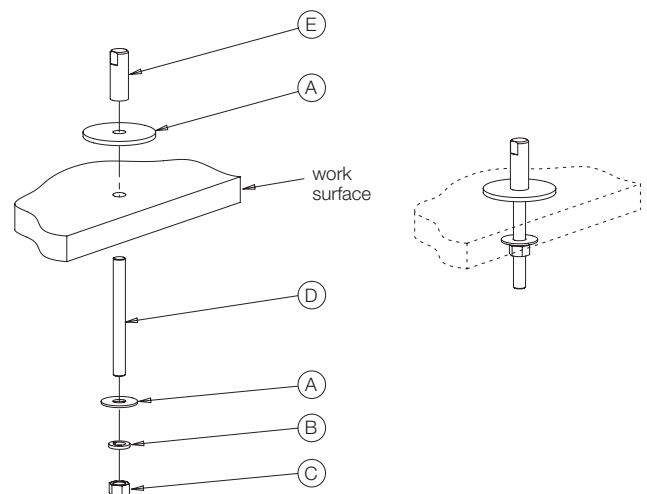

Antenna Table Center Beam Side Mount

Tools Needed

- Antenna Table Center Beam Side Mount to Slot Nuts – Phillips Screwdriver (C)

1. Insert (2) slot nuts (A) into side channel of beam of Antenna Big Table by pushing one side (long edge) down into the channel until the following edge/side drops into the channel.
4. Slide slot nuts (A) to desired mounting location. Assemble Antenna Table Center Beam Side Mount (B) by dropping bracket on side flange of beam (D) and securing with screws (C) into slot nuts (A). Tighten securely.

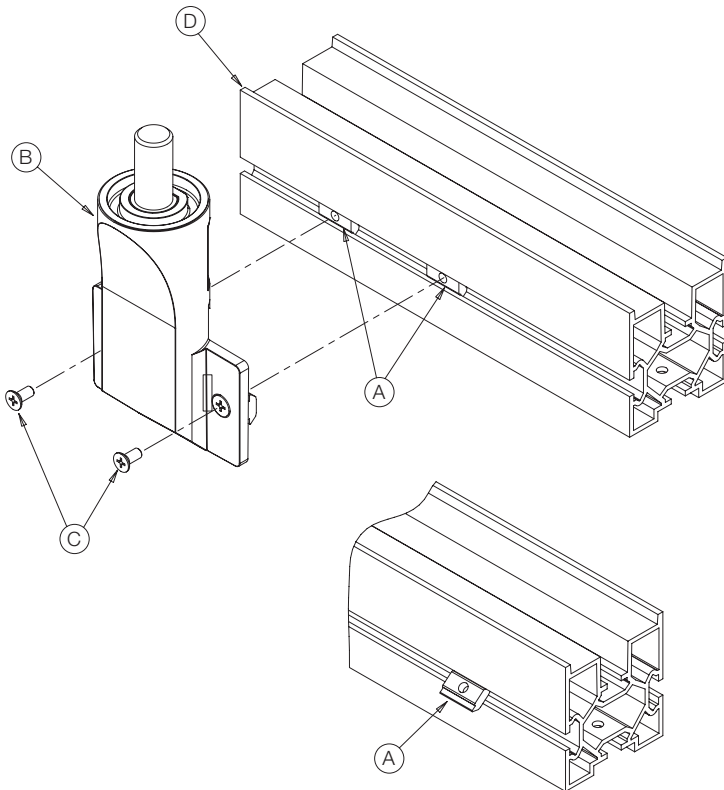

Step 2: Attach Monitor Arm to Mounts

Tools Needed

None

1. Install Sapper XYZ monitor arm by inserting the stem (A) into the hole (B) in the bottom of the post. Seat firmly.

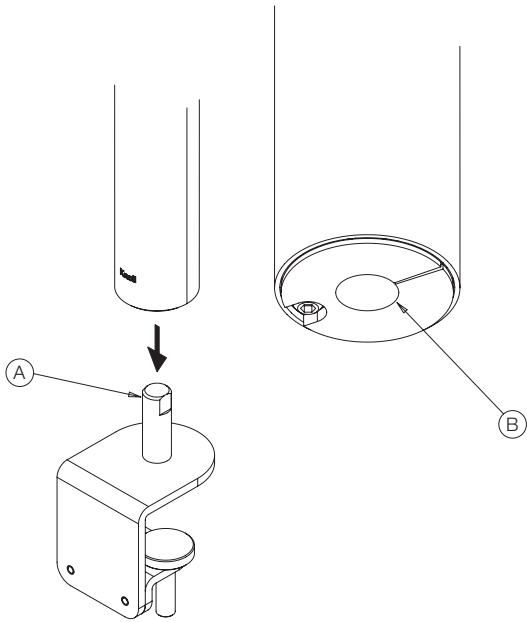

Step 3: Attach Monitor to Plate and Arm

Tools Needed

- Screwdriver or Allen wrench

1. Remove monitor base and hardware from the monitor. Retain all hardware.
2. Place movement joint (A) against back of monitor with Knoll logo toward top of monitor and attach the VESA plate (B) using appropriate hardware. VESA plate can accommodate 75 mm or 100 mm hole patterns.
3. Attach movement joint (A) with monitor to arm (E) by connecting them together, then inserting fast release pin (D).

Note: Movement joint can hold up to 20 lbs.

Note: Check VESA compliancy and hole pattern on monitor or television as Knoll monitor solutions are designed to work with VESA compliant monitors only. The Knoll VESA plate can accommodate 75mm or 100mm hole patterns. Knoll movement joints do not ship with screws and are designed to accept an M4 or M5 screw; length is dependent on the specific monitor or television and screw should be tested prior to installation to ensure correct length; Knoll is not responsible for use of

incorrect screws. If monitor has recessed VESA mounting surface, spacers (C) may be required between movement joint (A) and monitor. Spacers must be requested through Knoll Customer Service.

A VESA plate adaptor may be necessary for larger monitors and televisions and can be ordered separately in the sizes of 100 mm x 200mm (M5 screws), 200mm x 200mm (M6 screws), 300mm x 300mm (M8 screws) and 400mm x 400mm/400mm x 600mm (M8 screws). Adaptors ship with separate installation instructions and may require spacers. Knoll VESA plate adaptors ship with screws to attach the adaptor to the Knoll VESA plate but do not ship with screws to attach the adaptor to the monitor or television (see screw sizes listed above, English size equivalents may be needed instead); screw length is dependent on the specific monitor or television and screw should be tested prior to installation to ensure correct length, Knoll is not responsible for use of incorrect screws.

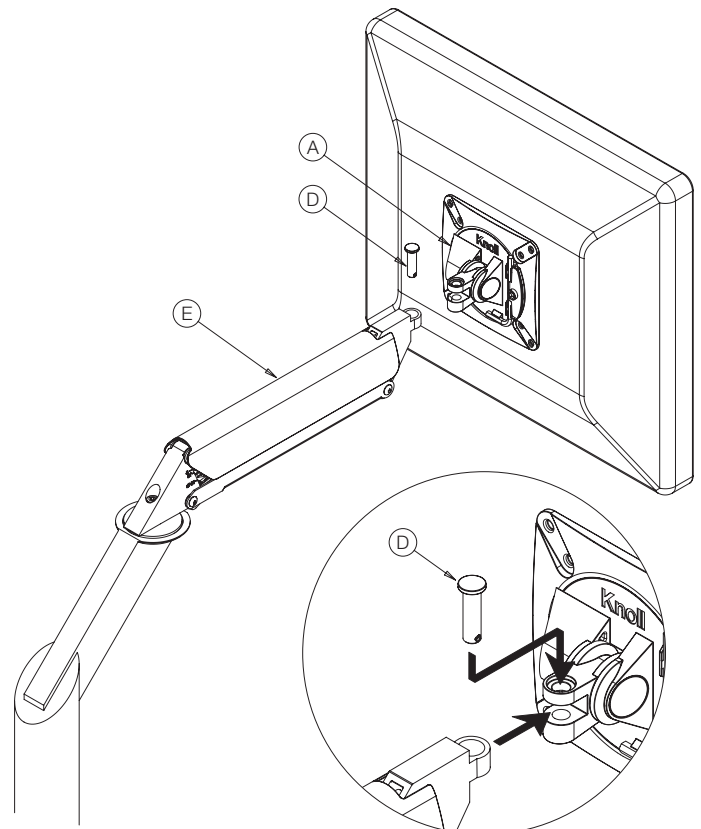
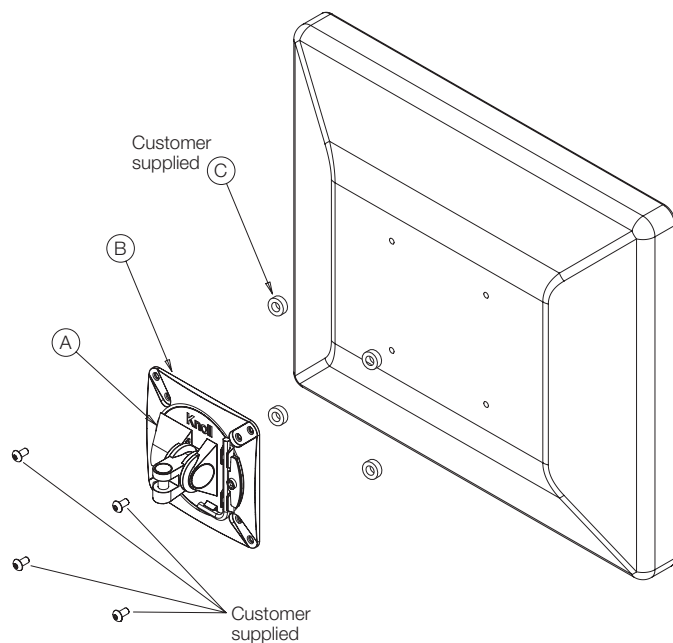

Features: Cable Management and Fast Release

Cable Management

1. Insert cables into the open channel (A) under the arm and secure them by pressing the cable management block (B) into the channel.
2. Secure cables down the post (C) by snapping cable management clip (D) over them.

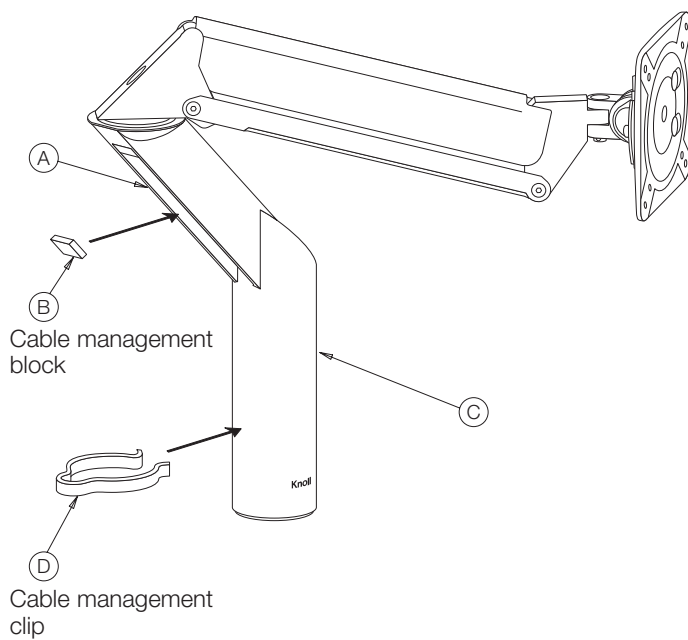

Fast Release

1. Fast release functionality allows rapid removal of monitor and movement joint. Lift monitor arm to its highest position while holding the monitor and remove the fast release pin (A) from the arm (B), disconnecting the movement joint (C).
2. To reinstall, position movement joint on monitor arm and insert fast release pin (A). When fully seated, pin should be flush.

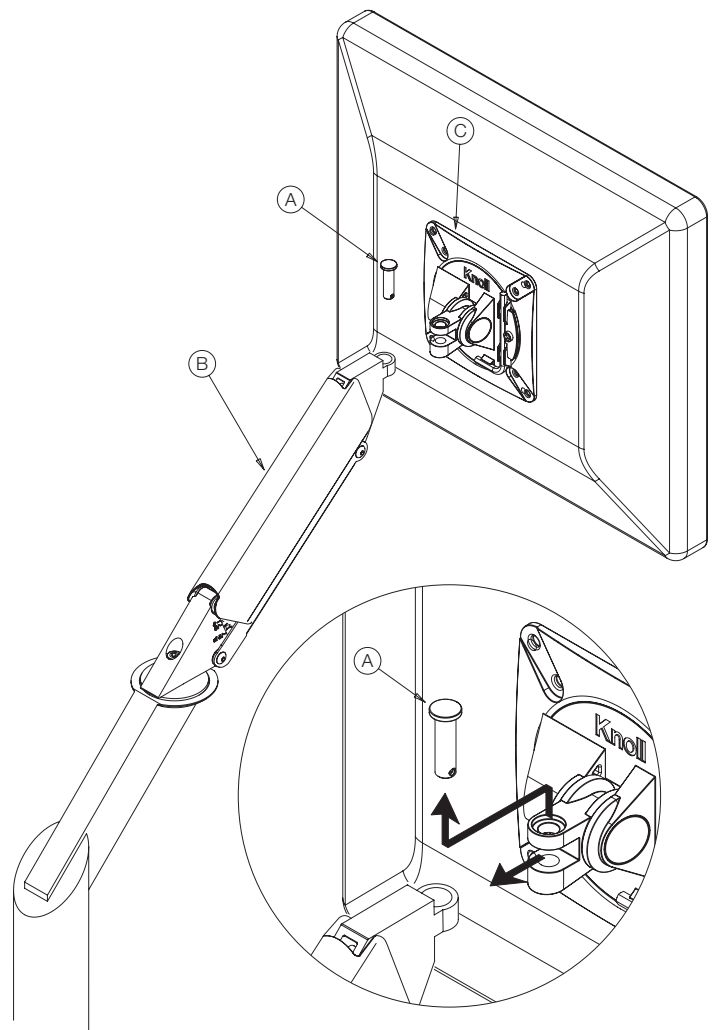

Features: Weight and Friction Adjustments

Tilt and Rotation Friction Adjustments

Tools Needed

Allen wrenches (in inches)

- Tilt friction – 3/16" (Included on Monitor Plate)
- Rotation friction – 3/16" (C) (Included on Monitor Plate)

Tilt friction:

To increase friction, insert Allen wrench (included on each monitor plate) (A) into screw (B) and turn clockwise. To reduce tilt friction, turn screw (B) counterclockwise. Adjust in very small increments.

Rotation friction:

To increase friction, insert Allen wrench (A) (included on each monitor plate) (C) and turn clockwise. To reduce friction, turn screw (C) counterclockwise. Adjust in very small increments.

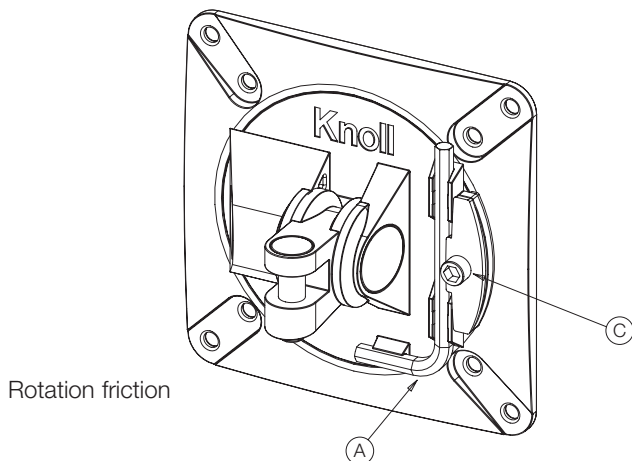
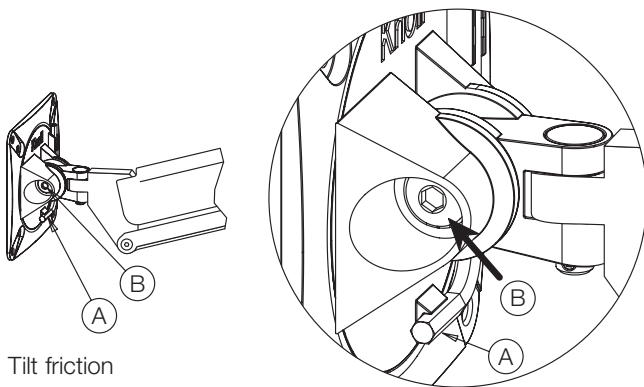

Weight Adjustment

Tools Needed

Allen wrenches (in inches)

- Weight adjustment – 3/16" (B) (Included on Monitor Plate)

1. Determine weight of monitor.
2. Weight tension is pre-set at 10 pounds. If monitor weighs more than that, lift the monitor up to adjust weight. If monitor weighs less, push the monitor down to adjust weight.
3. Insert Allen wrench (A) into weight adjustment nut (B). Turn clockwise to decrease weight or counterclockwise to increase weight to appropriate level. The red dial should point to the weight of your monitor. Kilograms are on one side and pounds are on the other.
4. Appropriate weight has been set when monitor stays exactly where you place it and can be moved with little resistance.

