

Y-Leg Flip-top Tables

Casters only

Related tables:

KYPW7236C

KYPW8436C

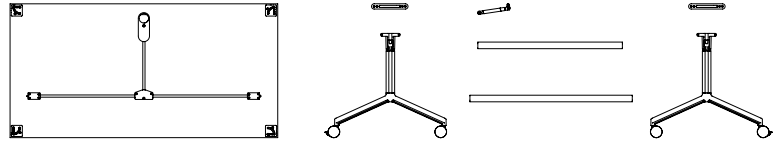

Unboxing

You should have received your top plus two boxes per table.

Box 1 includes:

Leg assemblies, hardware in a red plastic bag, and installation instructions.

Box 2 includes:

Horizontal rails

Parts list

- 1 Table top
- 2 Leg assemblies
- 2 Horizontal rails
- 2 Top brackets

Tools needed

- Allen wrenches
- Phillips screwdriver
- Torque wrench

Hardware

- 8 Flat head 1/4 - 20 screws
- 8 Socket cap head 1/4 - 20 screws
- 4 5/16" Shoulder screws
- 2 Vertical wire management clips (clear plastic)
- 4 Horizontal wire management clips with wood screws

Please pay close attention to torque requirements.

Step 1.

Attach the leg assemblies (A) on each end of the two horizontal rails (B) with flat head 1/4 - 20 screws (C), 4 per rail. Use 5/32" allen wrench, torque: 50 in/lbs

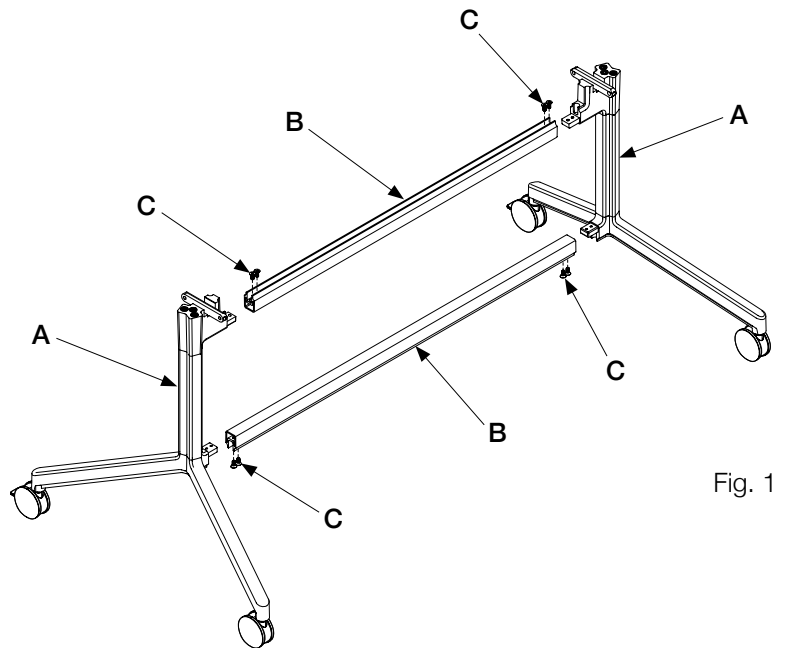

Fig. 1

Y-Leg Flip-top Tables

Step 2.

Lay the inverted table top on the floor.

Attach table top brackets (D) to table top with socket cap head 1/4 - 20 screws (E) 4 per bracket. Use 3/16" allen wrench, torque: 130 in/lbs

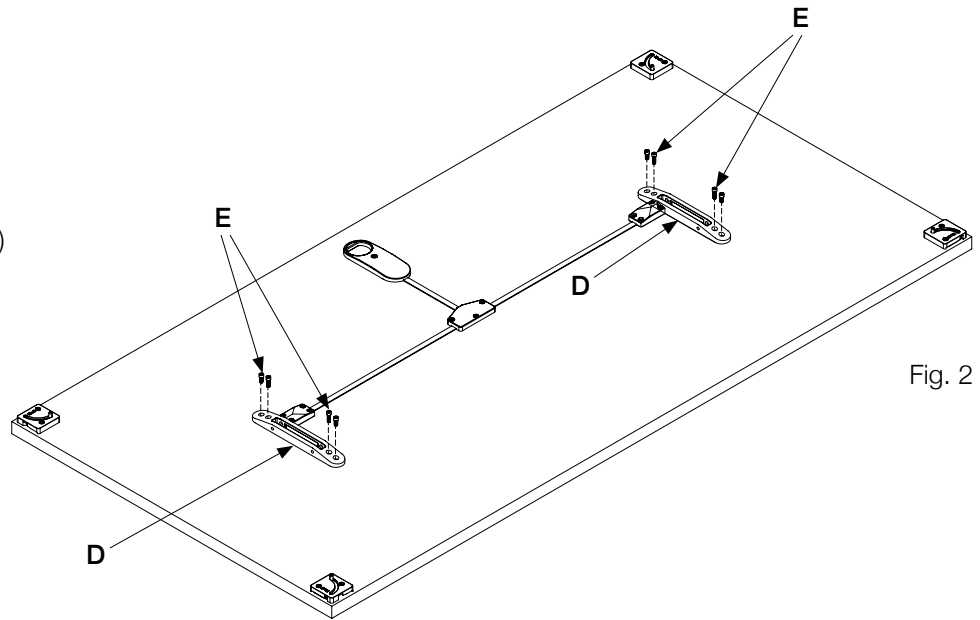

Fig. 2

Step 3.

Position the leg and horizontal rail subassembly (F) on the underside of the top. Align and attach the leg and horizontal rail subassembly with the table top brackets (G), using 5/16" shoulder screws (H), 2 per casting. Use 5/32" allen wrench, torque: 50 in/lbs

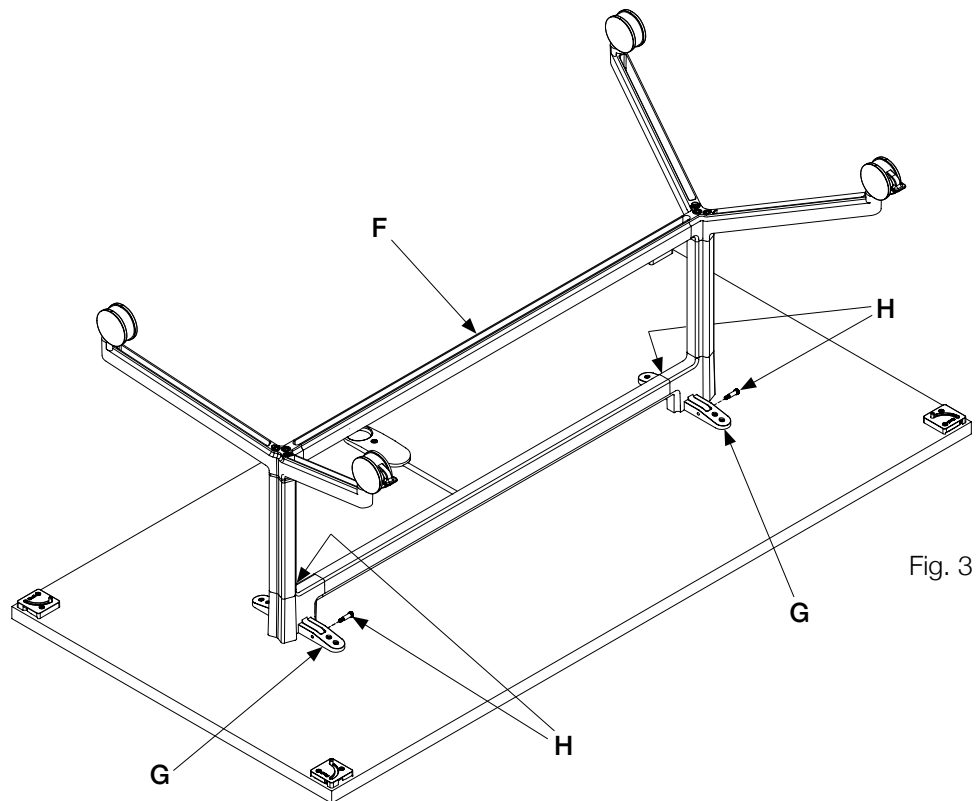

Fig. 3

Y-Leg Flip-top Tables

Step 4.

Turn the table assembly over into the upright position.

Step 5.

Attach the gas cylinder to the leg and horizontal rail subassembly (I) and the table top (J).

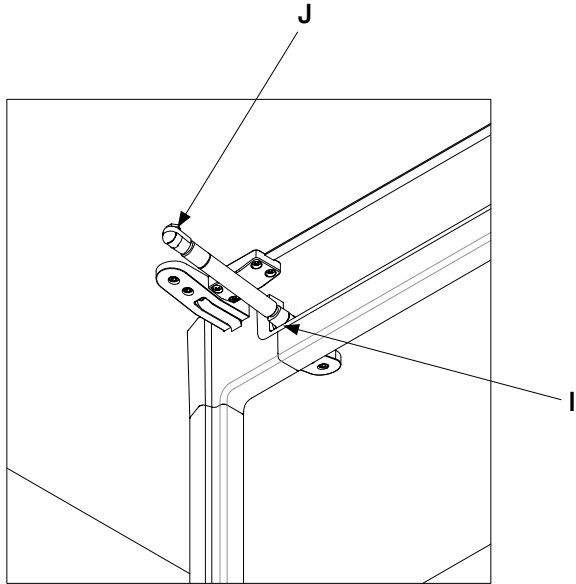

Fig. 4

All tables come with 2 vertical wire management clips, 4 horizontal wire management clips and wood screws for use with optional electronic modules. See separate electrical installation instructions for details.

If the table is being used as a stand-alone piece and the ganging mechanism will not be used, you can remove the mechanisms by unscrewing them.