

# Open Frame Leg Sets For Peninsula Applications

Reference Number: 6TP00440

HARDWARE LIST	
(A)	(B)
	
P/N VARIES LEG, OPN FRM\ASM	5134102 SCR, FLP #14x1-1/4 T-A ZN

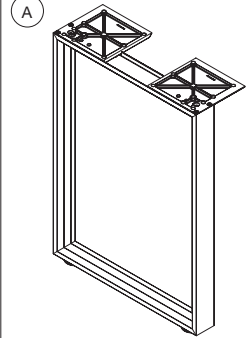
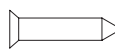
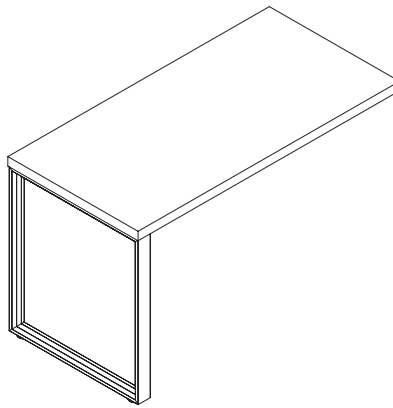

### Tools Needed

- Drill gun
- Phillips driver bit

### Before you begin

Work surfaces that have been designed explicitly for applications that use the Reff open frame leg are pre-drilled to locate and attach the leg.

However, in cases where the work surface is not designed to be used with the Reff open frame leg, the following instructions will assist with the proper positioning and attachment.

1. With the work surface positioned bottom-side-up, locate the leg (A) as required and using fastener (B) secure the connection (Fig. 1).

Note: Although the leg can be located virtually anywhere, the recommended location is centered on depth and inset 1/8" from the end, (Fig. 2)

2. The peninsula top is now ready for final assembly. Depending on the type of peninsula top (flush mount, power center stand-off or simple stand-off) the final installation will vary. For further instructions, go to the Knoll Exchange website at "[http://exchange.knoll.com/products/reffprofiles\\_inst.jsp](http://exchange.knoll.com/products/reffprofiles_inst.jsp)" or contact your Knoll representative.

Fig 1

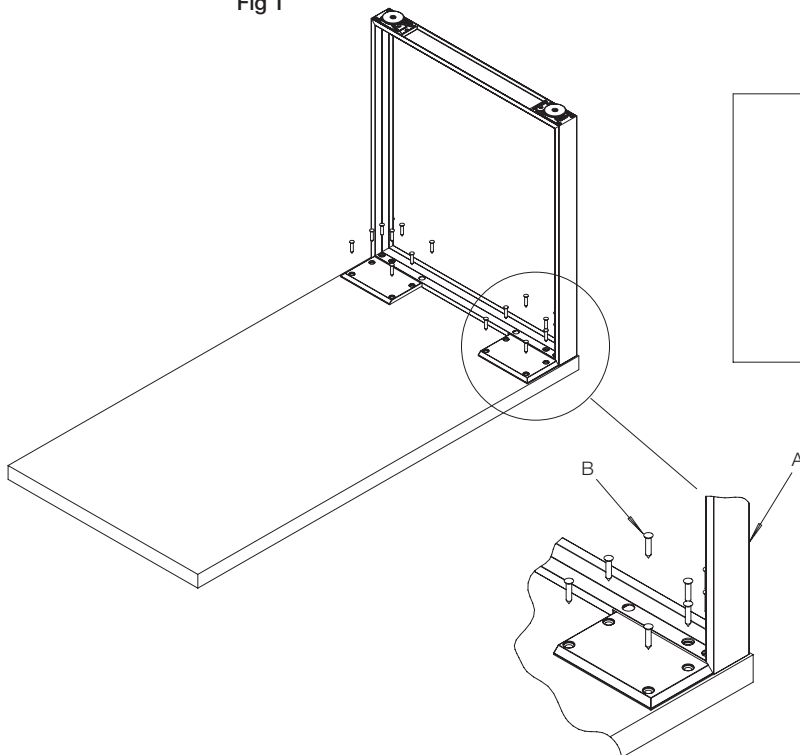

Fig 2

