

Highwire™ LED Undercabinet Light Installation Instructions

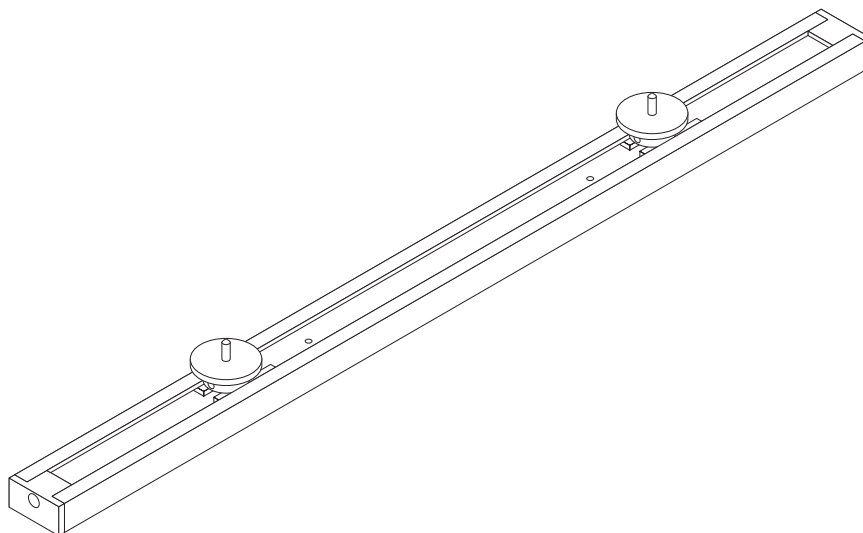

5AD730001 / 5AD720101 / 5AD730201 / 5AD730301
5AD734301 / 5AD734001 / 5AD734002 / 5AD734003 / 5AD734004
5AD734401 / 5AD734101 / 5AD734102 / 5AD734103 / 5AD734104
5AD734501 / 5AD734201 / 5AD734202 / 5AD734203 / 5AD734204

Tools Needed

- Phillips driver with #2 bit, #3 bit

Step 1

For steel cabinets

1. Adhere light fixture to cabinet at desired location using magnetic swivel mounts.

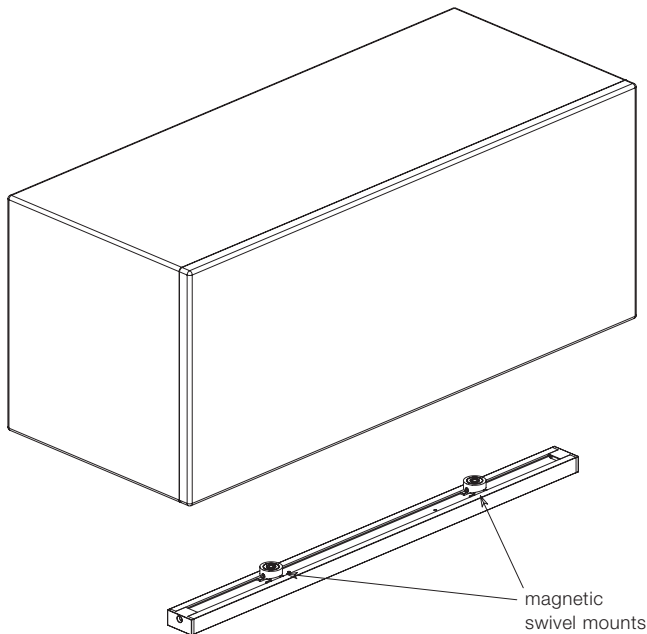

For non-ferrous cabinets

1. Install cup washers using screws supplied and adhere light fixture by contacting magnetic swivel mounts to cup washers.

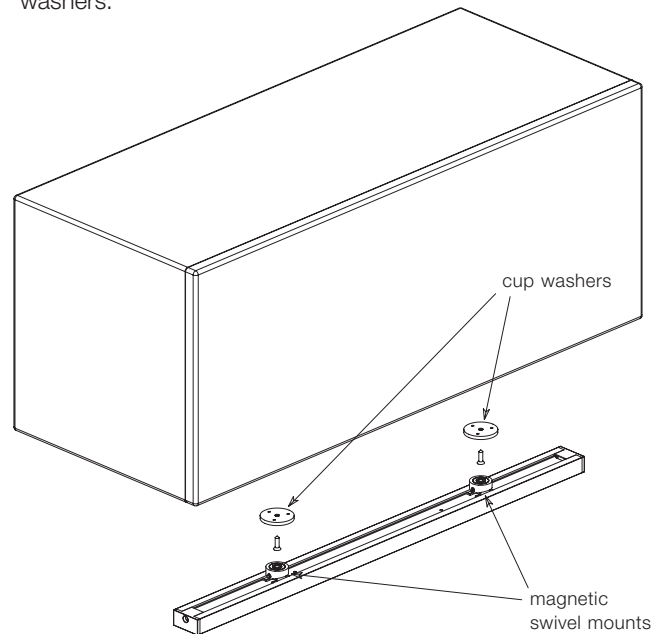

Step 2

1. Interconnect power adaptor to light fixture and in-line plug.
2. Plug into power outlet.
3. Choice of either light fixture end to connect to power adaptor – arrange for most convenient access to dimmer control.

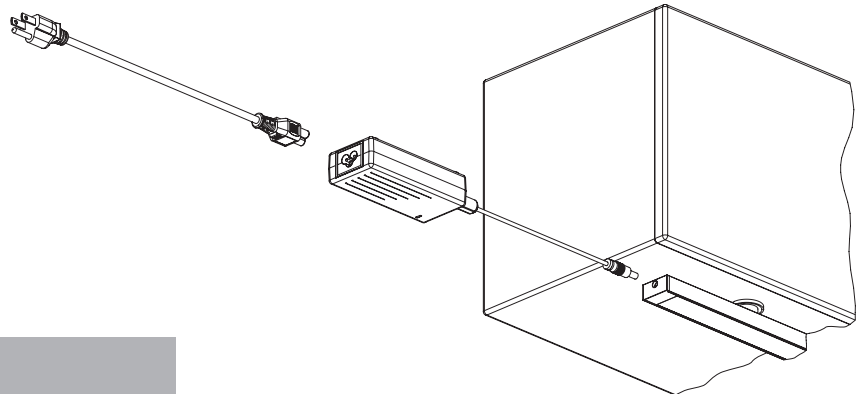

Step 3

For multiple light fixtures

1. To interconnect two adjacent light fixtures, use in-line jack or otherwise specified connector (3", 12", 24" or 36").
2. Choice of either light fixture end to interconnect – arrange for most convenient access to dimmer controls.

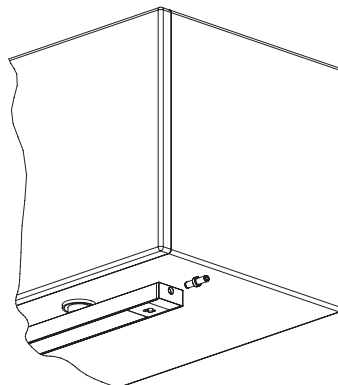

Note: Each light fixture has independent stepped dimmer for lighting control (100%, 60% and 30%).

Warning: Do not exceed a total of 60W when interconnecting light fixtures

Highwire	Wattage
19"	9W
37"	16W
67"	30W
79"	32W