

C-Leg Fixed Height Fixed-top Tables

Glides or casters

Related tables:

KCXW4818	KCXW4824	KCXW4830
KCXW6018	KCXW6024	KCXW6030
KCXW7218	KCXW7224	KCXW7230

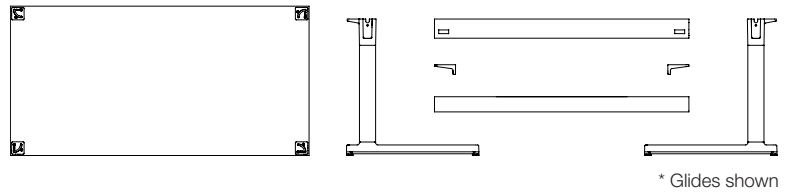

Unboxing

You should have received your top plus two boxes per table.

Box 1 includes:

Leg assemblies, table top support castings, hardware in a red plastic bag, and installation instructions.

Box 2 includes:

Wire management trough and flip door.

Parts list

- 1 Table top
- 1 Left C-leg assembly
- 1 Right C-leg assembly
- 2 Table top support castings
- 1 Wire management trough
- 1 Flip door
- 2 Warp preventers

Hardware

- 4 Socket cap head 1/4"-20 x 1" screws
- 8 Socket cap head 1/4"-20 x 2" screws
- 4 Flat head 1/4"-20 x 1/2" screws
- 8 Socket cap head 5/16"-18 x 1" screws
- 2 Vertical wire management clips (clear plastic)
- 4 Horizontal wire management clips with wood screws

Tools needed

- Allen wrenches
- Torque wrench
- Phillips screwdriver

Please pay close attention to torque requirements.

Step 1

Slide the flip door (A) in from the end of the wire management trough groove.

Step 2

Attach the wire management trough to the C-legs. Use socket cap head 1/4"-20 x 1/2" screws (B), 2 per leg, use 5/32" allen wrench, torque: 50 in/lb. Use flat head 1/4"-20 x 1" screws (C), 2 per leg, use 3/16" allen wrench, torque: 50 in/lb.

Step 3

Drop the trough end covers (D) into the slots on each leg upper casting.

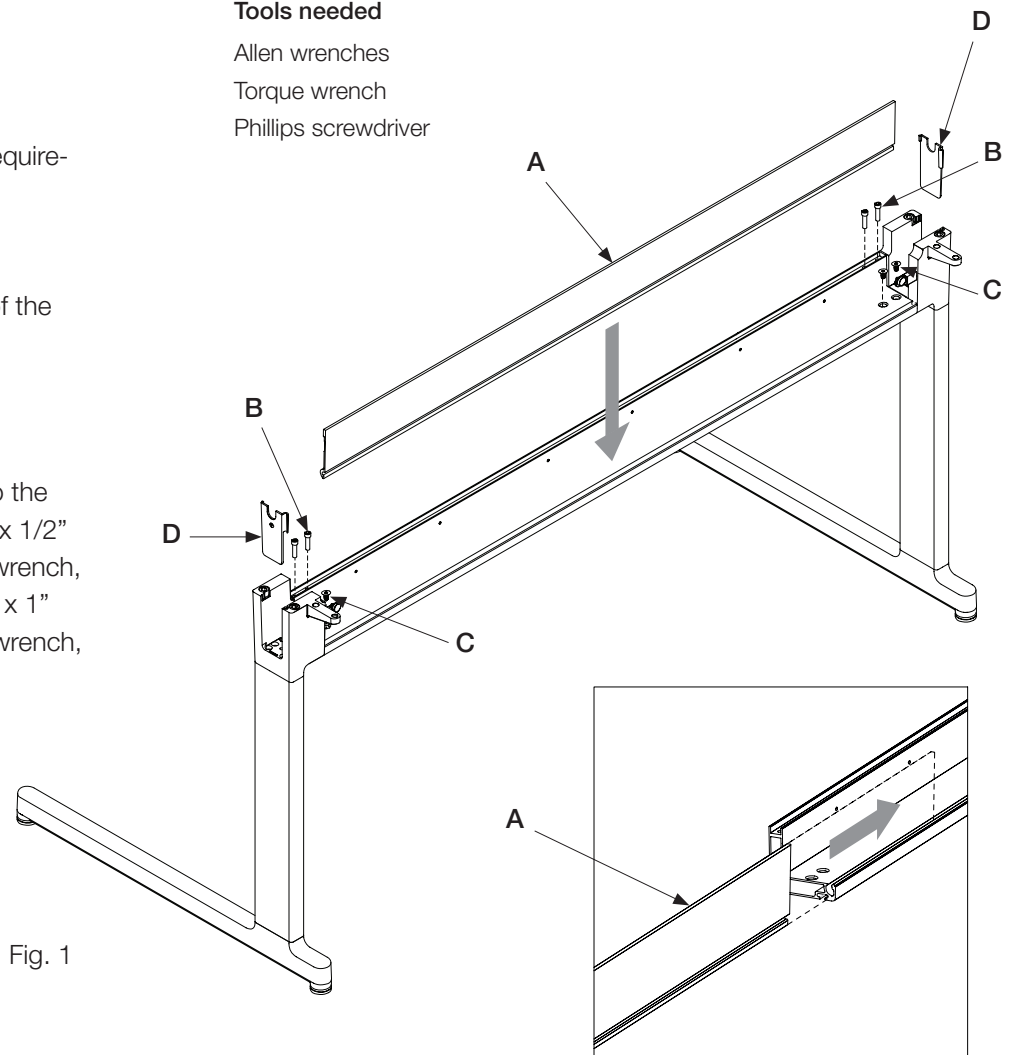

Fig. 1

Fig. 2

C-Leg Fixed Height Fixed-top Tables

Step 4

Attach the two table top support castings (E) to the trough with socket cap head 1/4"-20 x 2" screws (F), 2 per support, torque: 50 in/lb.

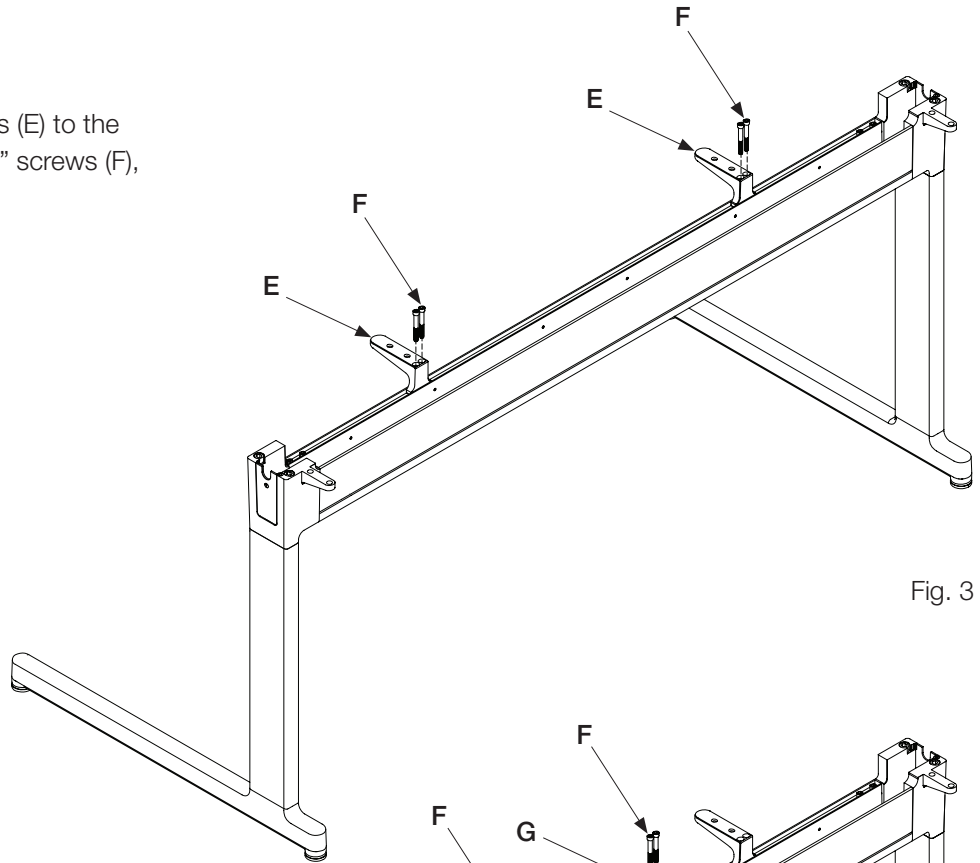

Fig. 3

Step 5

Attach the two warp preventers (G) to the trough with socket cap head 1/4"-20 x 2" screws (F), 2 per warp preventer, torque: 30 in/lb.

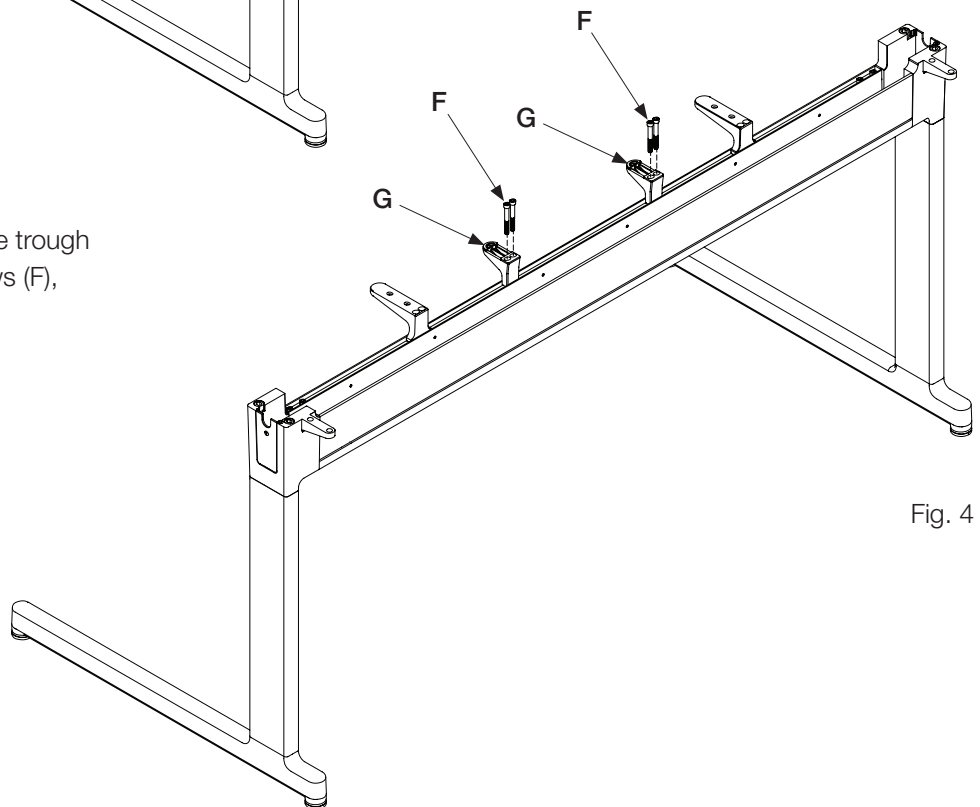

Fig. 4

C-Leg Fixed Height Fixed-top Tables

Step 6

Lay the inverted table top on the floor. Position the leg-trough assembly on the underside of the top.

Step 7

Align and attach the brackets with the threaded inserts in the top using 8 socket cap head 5/16"-18 x 1" screws (H), torque: 130 in/lb.

Step 8

Turn the table top assembly over into the upright position.

All tables come with 2 vertical wire management clips, 4 horizontal wire management clips and wood screws for use with optional electrical modules. See separate electrical installation instructions for details.

If the table is being used as a stand-alone piece and the ganging mechanism will not be used, you can remove the mechanisms by unscrewing them.

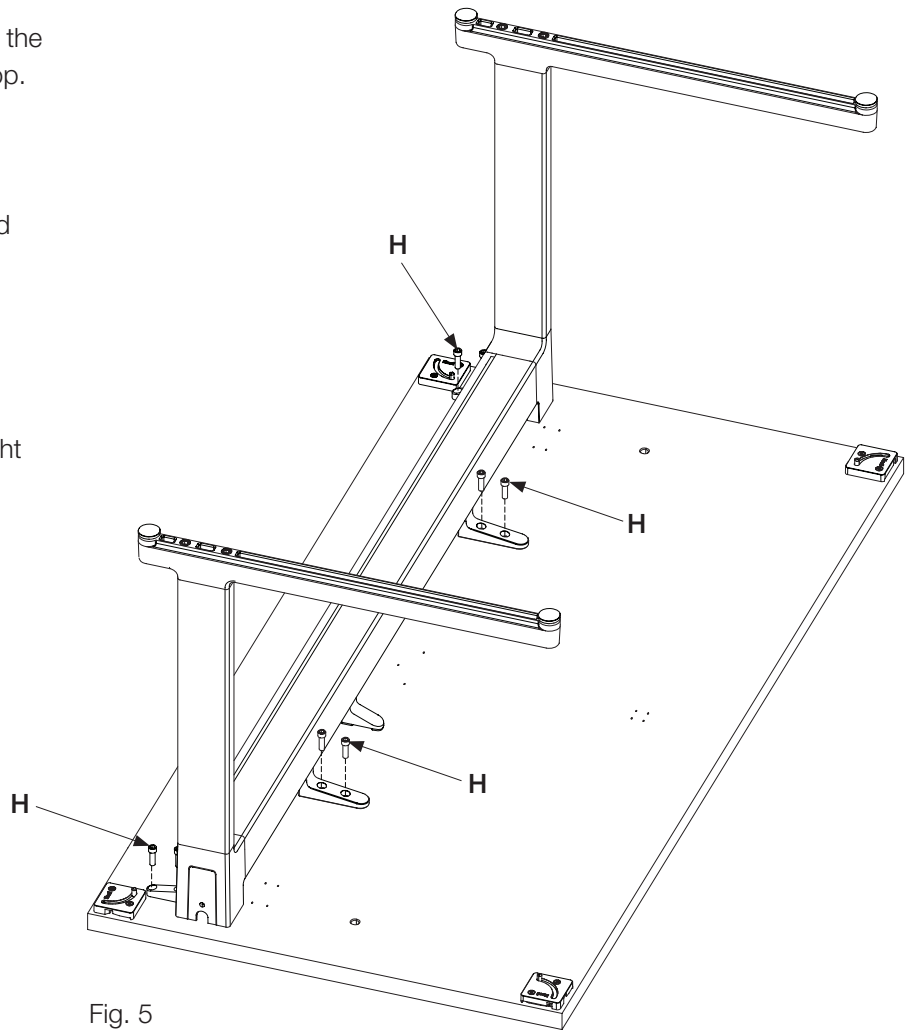

Fig. 5