

T-Leg Height Adjustable Fixed-top Tables

Glides or casters

Related tables:

- KTXA6030 KTXA6036
- KTXA7230 KTXA7236

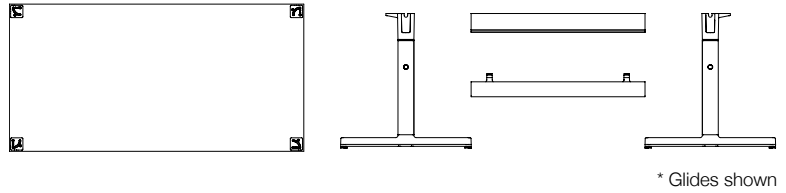

Unboxing

You should have received your top plus two boxes per table.

Box 1 includes:

T-Leg assemblies, hardware in a red plastic bag, and installation instructions.

Box 2 includes:

Wire management trough and flip door.

Please pay close attention to torque requirements.

Step 1.

Slide the flip door (A) in from the end of the wire management trough groove.

Step 2.

Attach the wire management trough to the T-legs. Use socket cap head 1/4"-20 x 1" screws (C), 2 per leg, use 5/32" allen wrench, torque: 50 in/lb.

Use flat head 1/4"-20 x 1/2" screws (D), 2 per leg, use 3/16" allen wrench, torque: 50 in/lb.

Step 3.

Drop the trough end covers (B) into the slots on each leg upper casting.

Parts list

- 1 Table top
- 1 Left T-leg assembly
- 1 Right T-leg assembly
- 2 Table top support castings
- 1 Wire management trough
- 1 Flip door

Tools needed

- Phillips screwdriver
- Allen wrenches
- Torque wrench

Hardware

- 4 Socket cap head 1/4"-20 x 1" screws
- 4 Socket cap head 1/4"-20 x 2" screws
- 4 Flat head 1/4"-20 x 1/2" screws
- 10 Socket cap head 5/16"-18 x 1" screws
- 2 Vertical wire management clips (clear plastic)
- 4 Horizontal wire management clips with wood screws

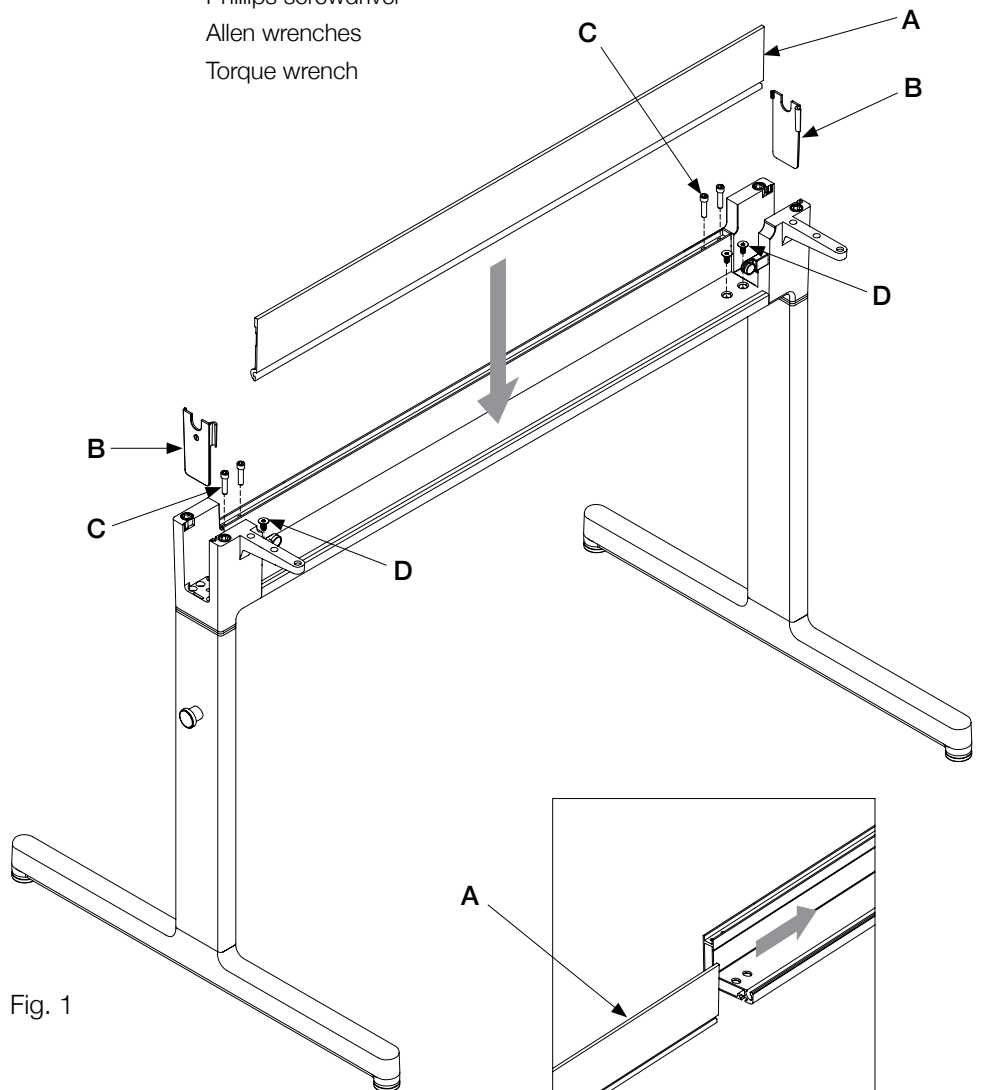

Fig. 1

Fig. 2

T-Leg Height Adjustable Fixed-top Tables

Step 4.

Attach the two table top supports (E) to the trough with socket cap head 1/4"-20 x 2" screws (F), torque: 50 in/lb, 2 per support.

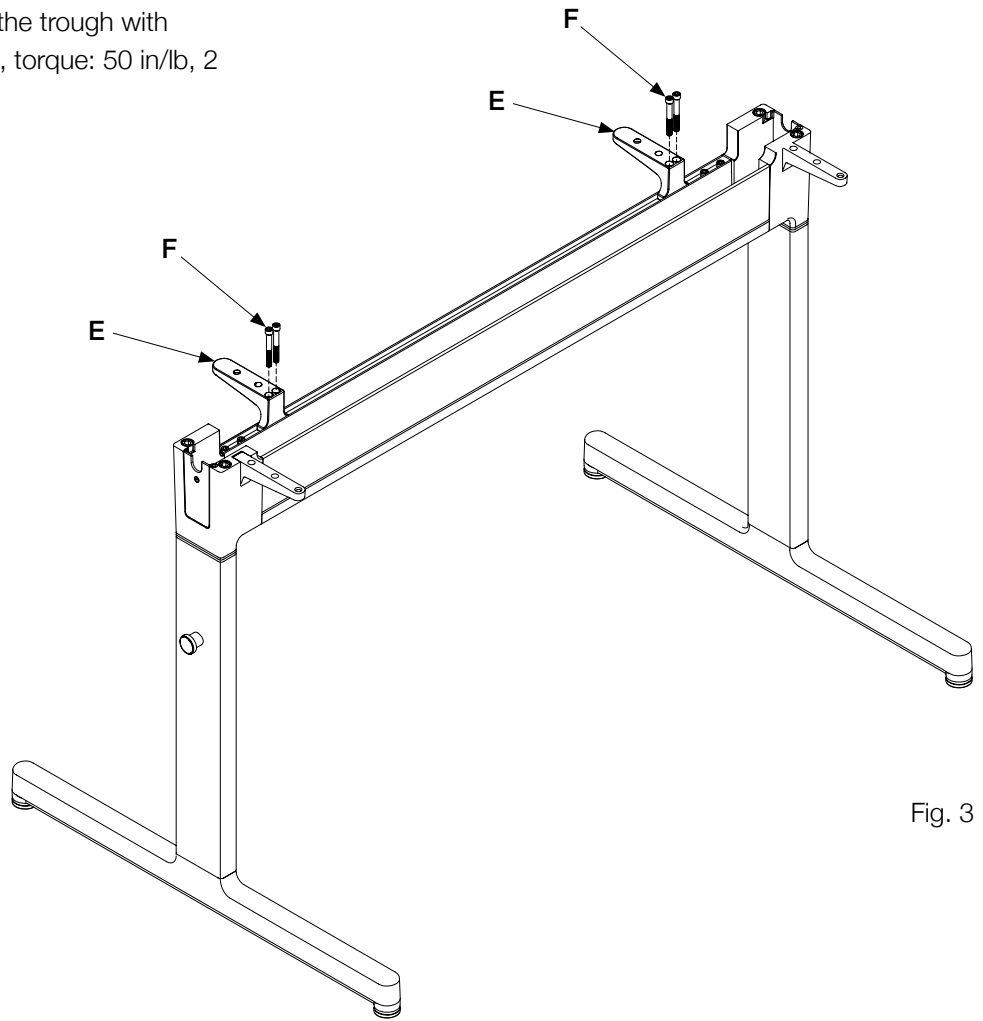

Fig. 3

T-Leg Height Adjustable Fixed-top Tables

Step 5.

Lay the inverted table top on the floor. Position the leg-trough assembly on the underside of the top.

Step 6.

Align and attach the brackets with the threaded inserts in the top using 10 socket cap head 5/16"-18 x 1" screws (G), torque: 130 in/lb.

Step 7.

Turn the table top assembly over into the upright position.

All tables come with 2 vertical wire management clips, 4 horizontal wire management clips and wood screws for use with optional electrical modules. See separate electrical installation instructions for details.

If the table is being used as a stand-alone piece and the ganging mechanism will not be used, you can remove the mechanisms by unscrewing them.

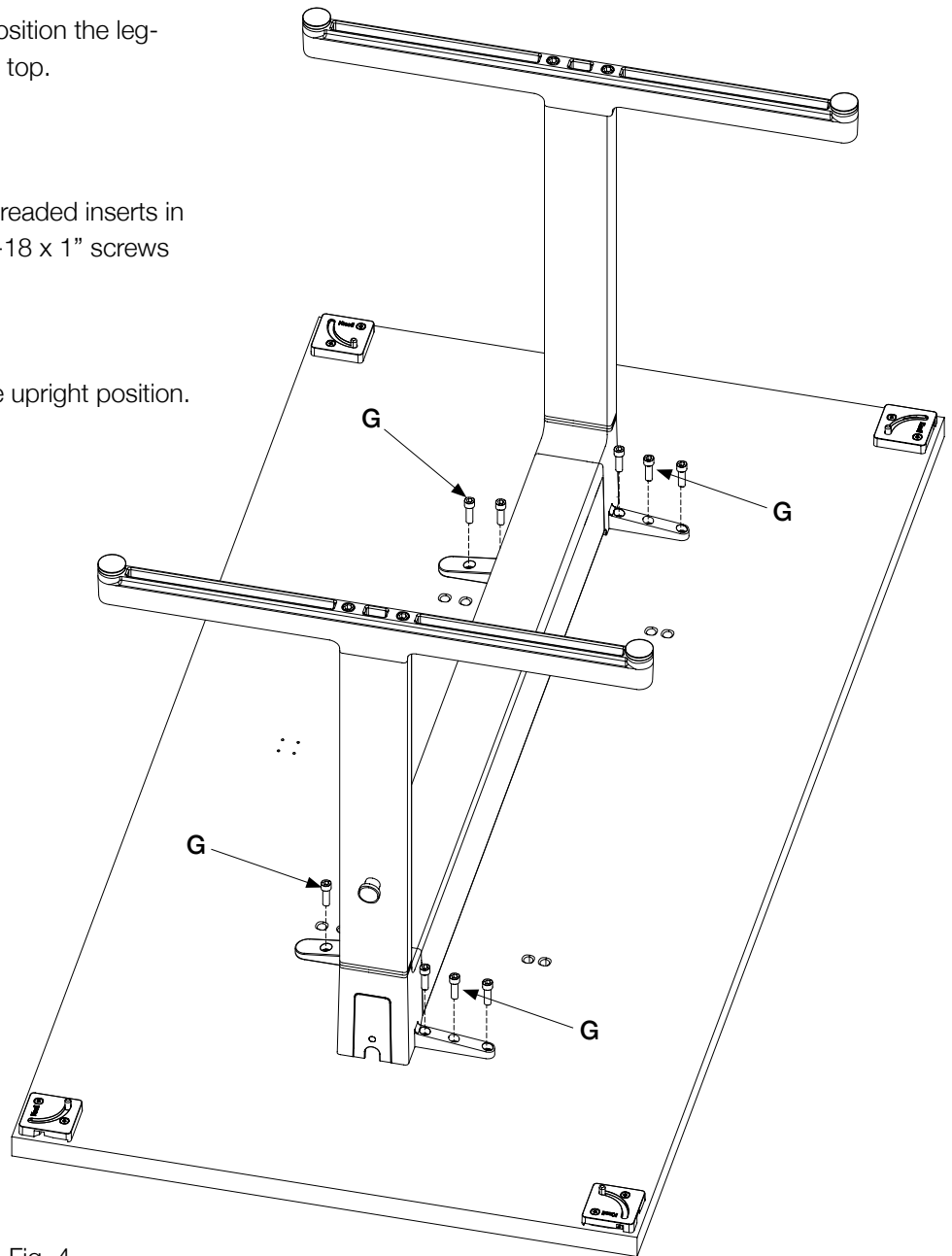

Fig. 4

T-Leg Height Adjustable Fixed-top Tables - Operating Instructions

To adjust the table height:

Step 8.

Begin on one side of the table. Rest your foot on the lower casting (H).

Step 9.

Pull the spring pin knob (I) and lift table top to the desired height

Step 10.

At the approximate desired height, let the top slide downwards until the spring pin re-engages in the lock position.

Step 11.

Go to second side. Pull pin (J) and lift to height desired. Let pin re-engage.

The maximum height is 34 inches measured from the top of the table to the floor.

All tables come with 2 vertical wire management clips, 4 horizontal wire management clips and wood screws for use with optional electrical modules. See separate electrical installation instructions for details.

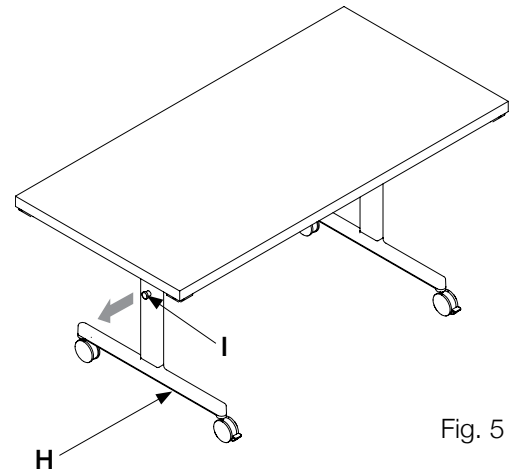

Fig. 5

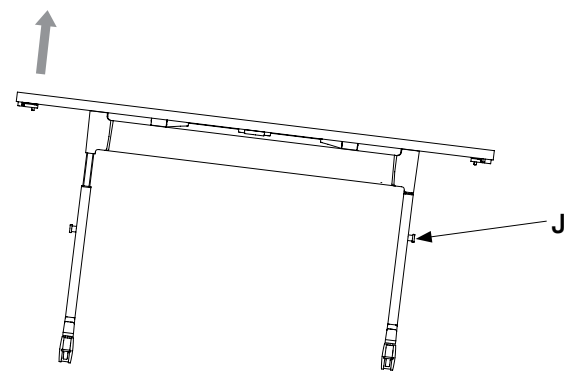

Fig. 6

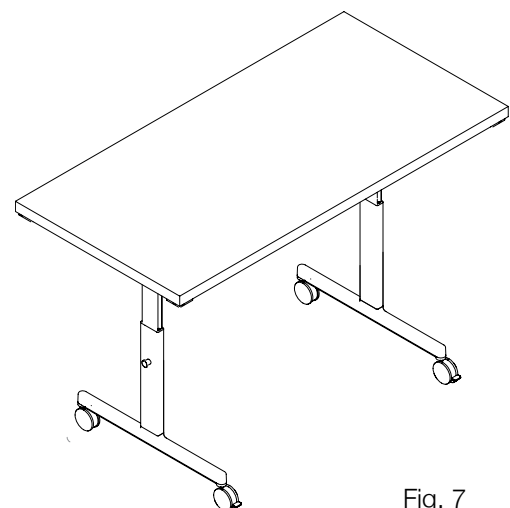

Fig. 7