

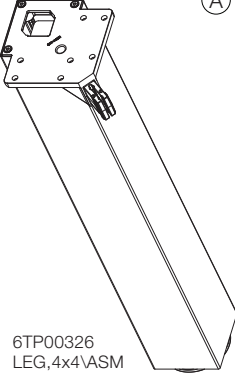

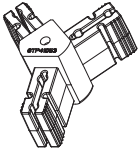

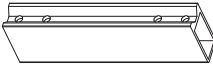

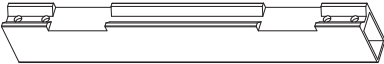

Double Worksurface Depth x Single Worksurface Width Meeting Table with 4x4 Leg

Reference Number: 6tp00459

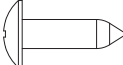
HARDWARE LIST			
 <p>(A) 6TP00326 LEG, 4x4\ASM</p>	 <p>(B) 6TP41053 CONN, FRAME\Y</p>	 <p>(C) P\N VARIES FRAME, CROSS-MEMBER</p>	 <p>(D) 6TP41444 FRAME, MILLED\SHORT</p>
		 <p>(E) P\N VARIES FRAME, MILLED\LONG</p>	
 <p>(F) P\N VARIES TOP</p>	 <p>(G) 5134102 SCR, FLP #14x1-1/4 T-A ZN</p>	 <p>(J) 5122218 SCR, TRP 14x7/8 T-AB BL (BACK PACK)</p>	
 <p>(H) 6TP41509 or 6TP41454 BRACKET BAT\FRM\INTER</p>	 <p>(I) 6TP41453 BRKT, TABLE\TOP-TOP, 5x3</p>	 <p>(K) 6TP41511 BRKT, BAT\MID-SPAN\CANT\BTM</p>	

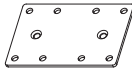

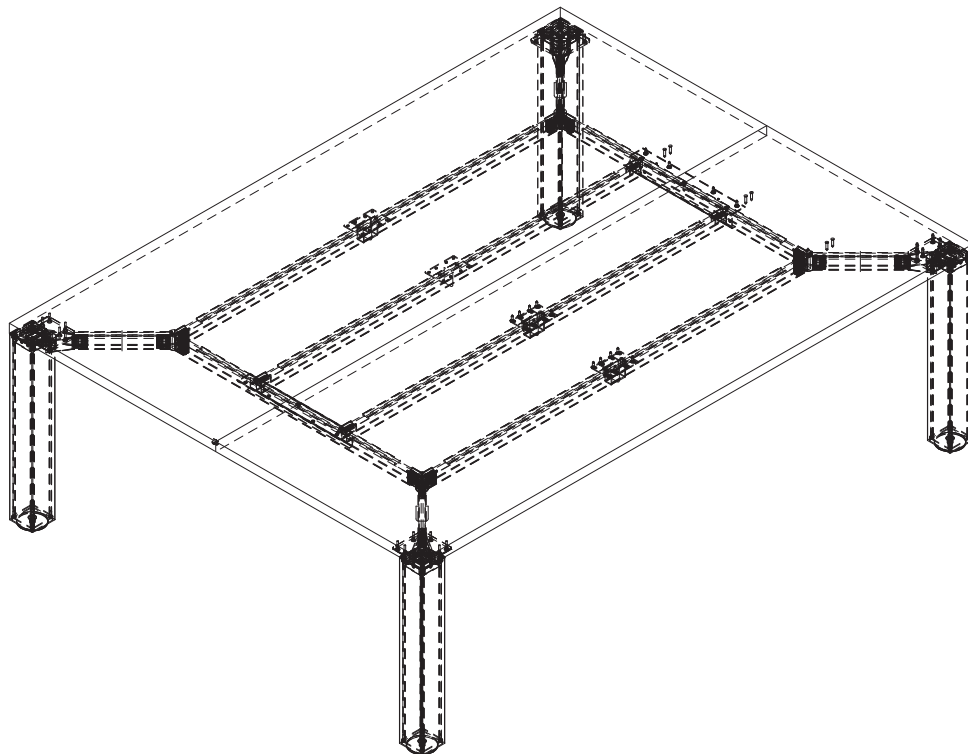
Double Worksurface Depth x Single Worksurface Width Meeting Table with 4x4 Leg

Reference Number: 6tp00459

Tools Needed

- Drill gun
- #3 Phillips driver bit
- Tape measure

1. Assembly instructions

1.1 Frame sub-assembly

- 1.1.1. On a large flat surface, arrange components (B), (C), (D), (E), (H) and (I) as required. (Fig. 1)
- 1.1.2. Using fastener (G) secure all components to complete the frame sub-assembly. (Fig. 2)

1.2. Leg attachment

- 1.2.1. Using fastener (G) secure each leg (A) to the frame sub-assembly. (Fig. 3)

1.3. Top attachment

- 1.3.1. Using fastener (G) secure the top (F) using the pilot holes provided for proper position. (Fig. 4)
- 1.3.2. Using fastener (J) secure the bracket (H) and (I) to the top. (Fig. 4)

2. Optional accessories

- 2.1. Installation instructions for any optional accessories (ordered separately, see price list) are available on the Knoll Exchange website at "http://exchange.knoll.com/products/installation_instructions.jsp" or contact your Knoll representative.

