









Executive Height Adjustable Desks

Reference Number: 6TP00499

HARDWARE LIST			
<p>(A) </p> <p>P/N: 5122213 SCR, #10-9 X 11/16 #2 QUADREX</p>	<p>(B) </p> <p>P/N: 6TP41977 BRKT, TOP\CONCEALER\LEG</p>	<p>(C) </p> <p>P/N: 6TP41309 GROM, LEG\ADJ\RND\WA, 80MM</p>	<p>(D) </p> <p>P/N: 5112035 SCR, #8 x 3/8 #2 ROBERTSON</p>
<p>(E) </p> <p>P/N: 5112200 SCR, #10 x 1/2 #2 ROBERTSON</p>	<p>(F) </p> <p>P/N: 5112210 SCR, PNP #10 x 5/8 #3 PHILLIPS</p>	<p>(G) </p> <p>P/N: 5122218 SCR, TRP #14 x 7/8 #3 PHILLIPS</p>	<p>(H) </p> <p>P/N: 6TP42007 TEMPLATE</p>

Tools Needed

- Drill gun
- 5/32" - Drill bit (for recessed modesty only)
- #2 - Quadrex driver bit
- #2, #3 - Phillips driver bit
- #2 - Robertson driver bit

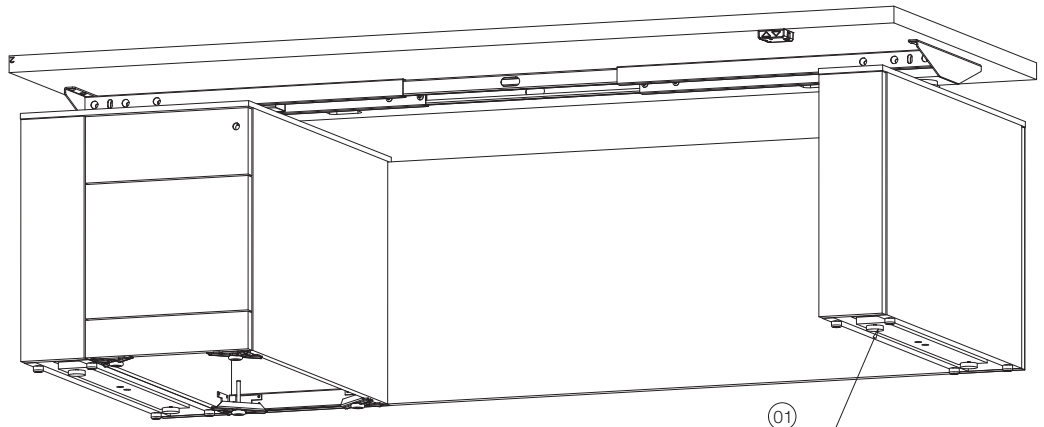

In case of extremely un-level surfaces, use 3" extended levelers on either side of this desk; part #KR5442110.

- 1.1. Attach brackets (B) to the tops using screws (D). Insert leg surround tops & grommets (C). (Fig. 1)

Fig 1

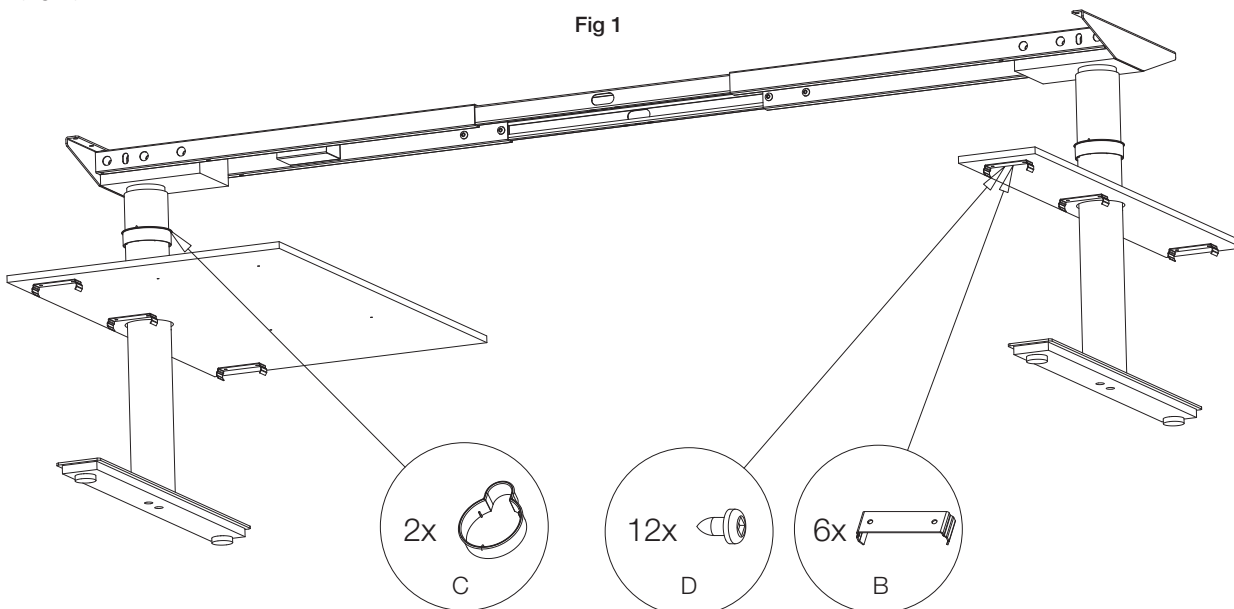

Executive Height Adjustable Desks

Reference Number: 6TP00499

2.1. Detach the inside back (by turning CCW the rawfix cams), slide leg surround in place and reattach the inside backs. (Fig. 2.1)

2.2. Slide in the LH/RH pedestal if lower storage is required. (Fig. 2.2)

Fig 2.1

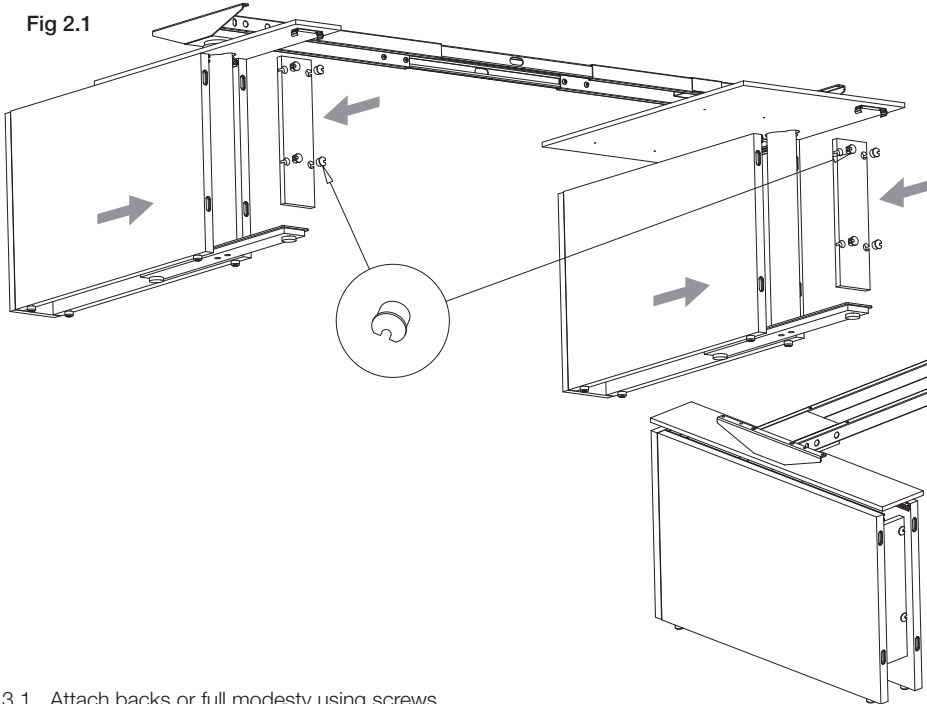
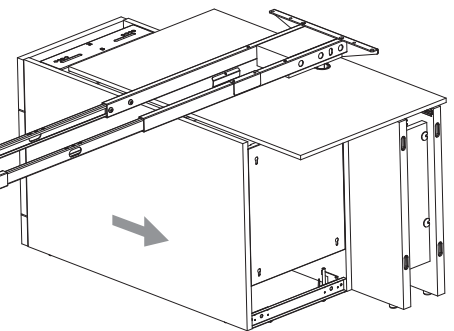

Fig 2.2



3.1. Attach backs or full modesty using screws (A) and (F). Connect pedestal to top using screws (E). (Fig. 3.1 and Fig. 3.2)

Fig 3.1 Backs (no Modesty)

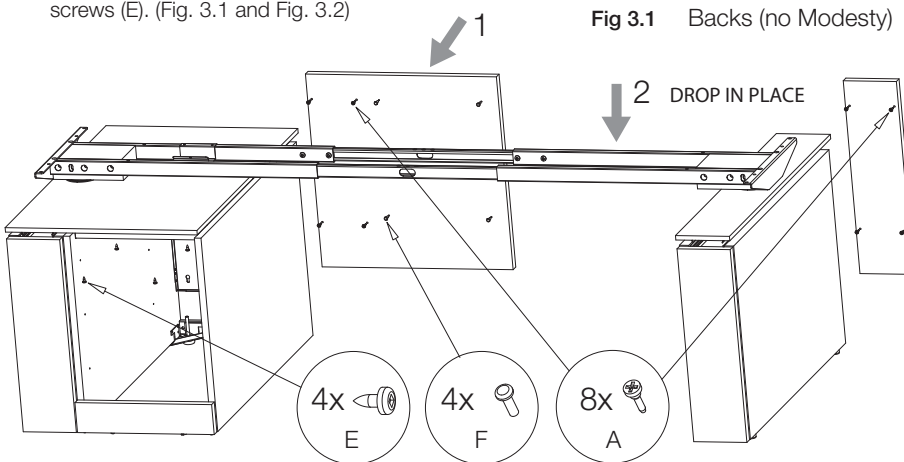
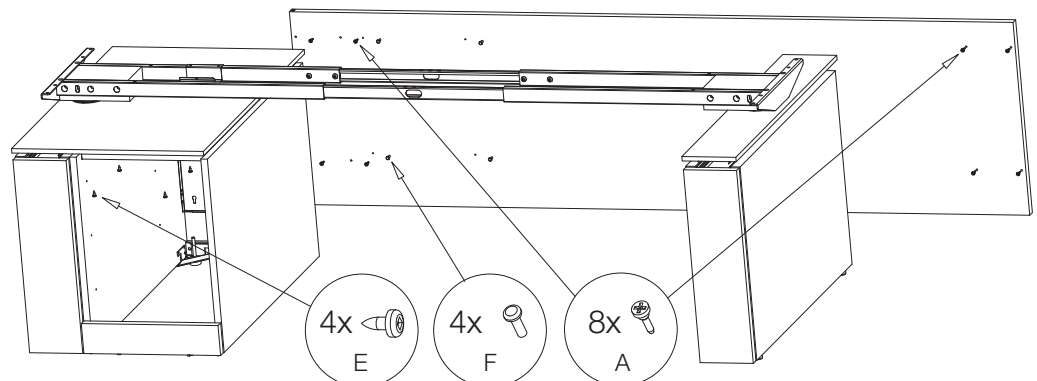

Fig 3.2 Full Modesty



Executive Height Adjustable Desks

Reference Number: 6TP00499

- 4.1. Drill \varnothing 5/32" x 1/2" deep holes on marked locations if recessed modesty is required. (Fig. 4.1)

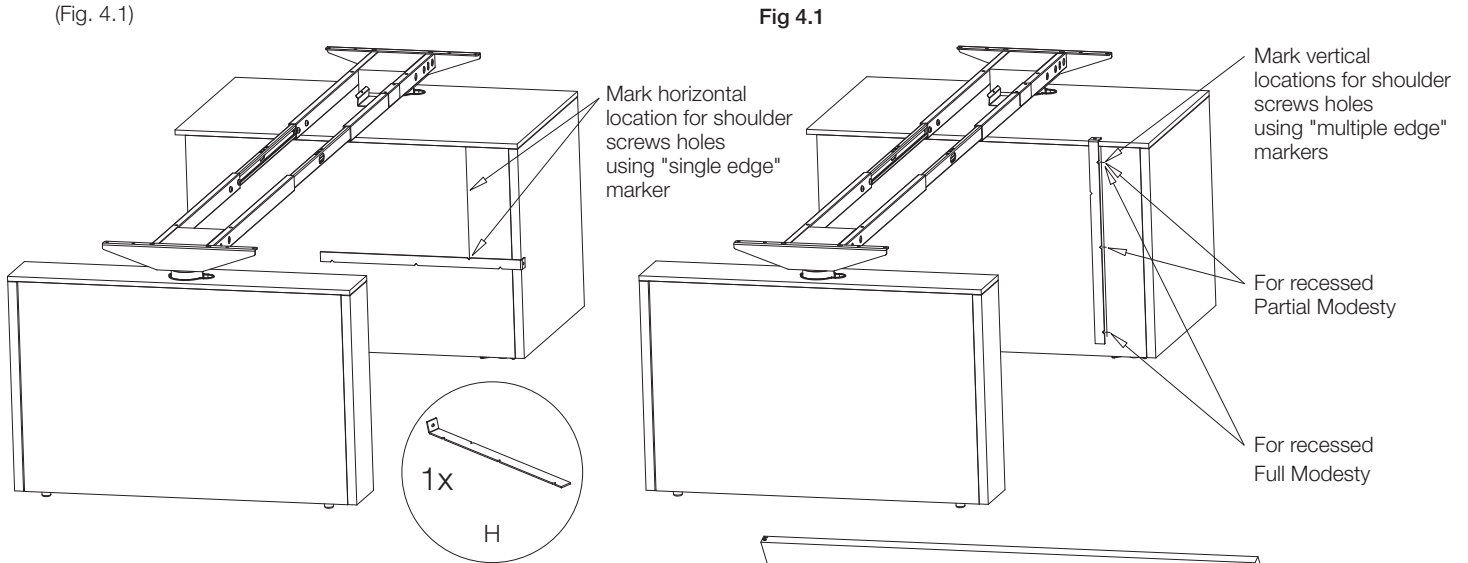

- 4.2. Screw in the shoulder screws (A) and attach the recessed modesty. (Fig. 4.2)

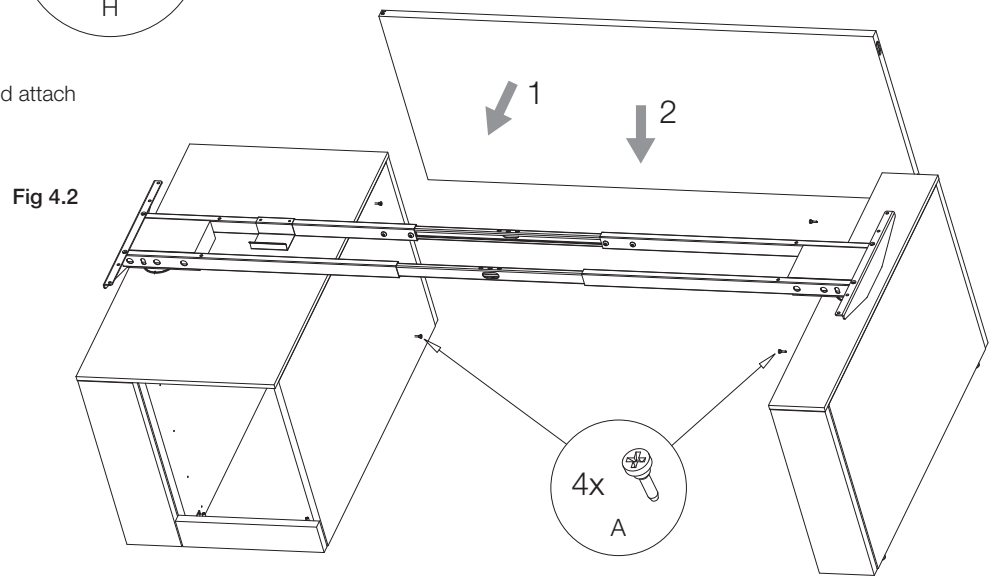

- 5.1. Drop in place and secure the worksurface using screws (G). (Fig. 5)

