

# Knoll

Knoll Systems  
Installation Instructions

## TABLE POWER CENTER OUTLET

311

- Corded -

Instruction Number: 6TP00534

This device complies with part 15A of the FCC Rules. Operation is subject to the following two conditions: (1) This device may not cause harmful interference, and (2) this device must accept any interference received, including interference that may cause undesired operation.

Tools Required



**\*NOTE\***

All Tech Adapters Need to be Mounted in the  
↑ "UP" ↑ Position. (Refer to the back of Parts)

### 1 Remove Metal Bracket

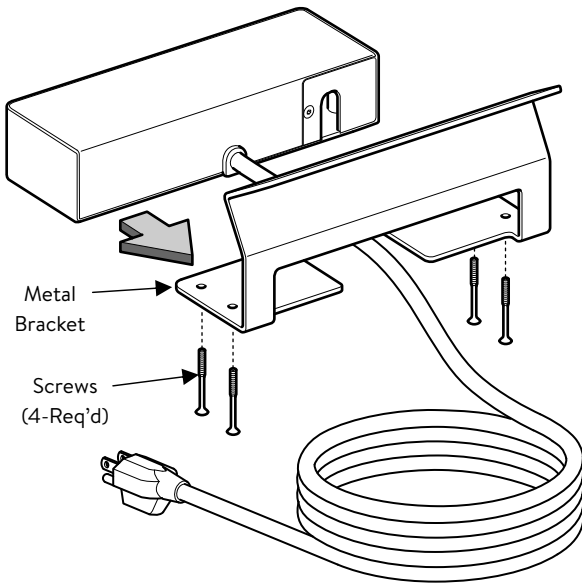

### 2 Remove Data Port Cover and Blank Adapter

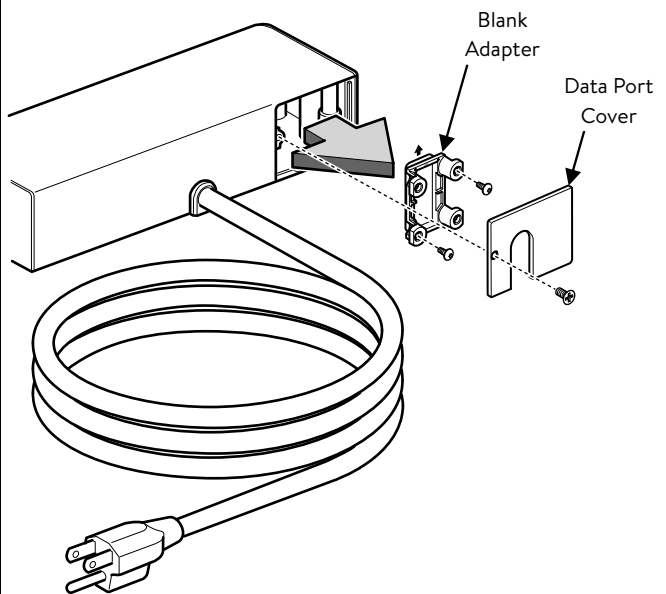

### 3 Install Data Port Options - (VGA, RJ45, HDMI, BLANK)

**\*NOTE\***

See Sheet #2 for Detailed Instructions

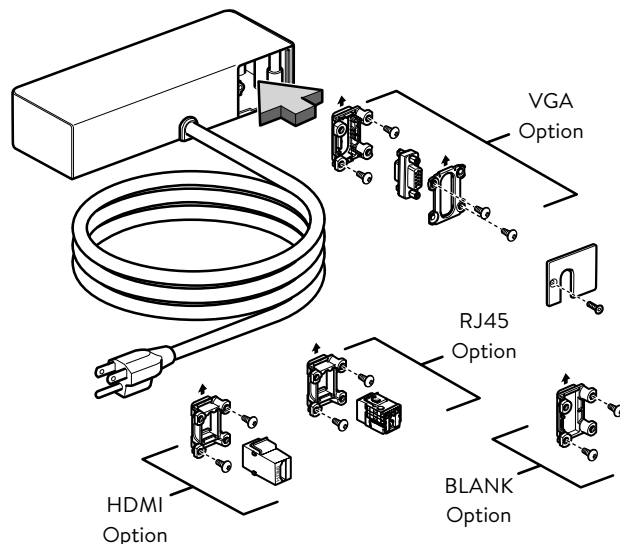

### 4 Install Data Port Cover and Metal Bracket

**\*NOTE\***

Route Cord Through Opening Before Installing Bracket

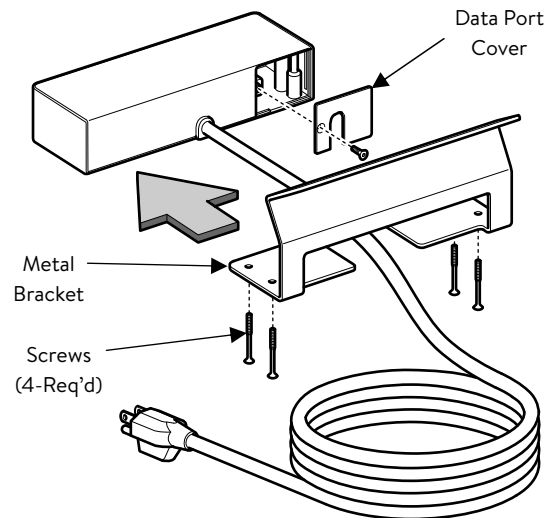

# Knoll

Knoll Systems  
Installation Instructions

## TABLE POWER CENTER OUTLET

311  
- Corded -

Instruction Number: 6TP00534

This device complies with part 15A of the FCC Rules. Operation is subject to the following two conditions: (1) This device may not cause harmful interference, and (2) this device must accept any interference received, including interference that may cause undesired operation.

### Tools Required



### \*NOTE\*

All Tech Adapters Need to be Mounted in the  
↑ "UP" ↑ Position. (Refer to the back of Parts)

### 3.1 Install Data Tech Adapter Option

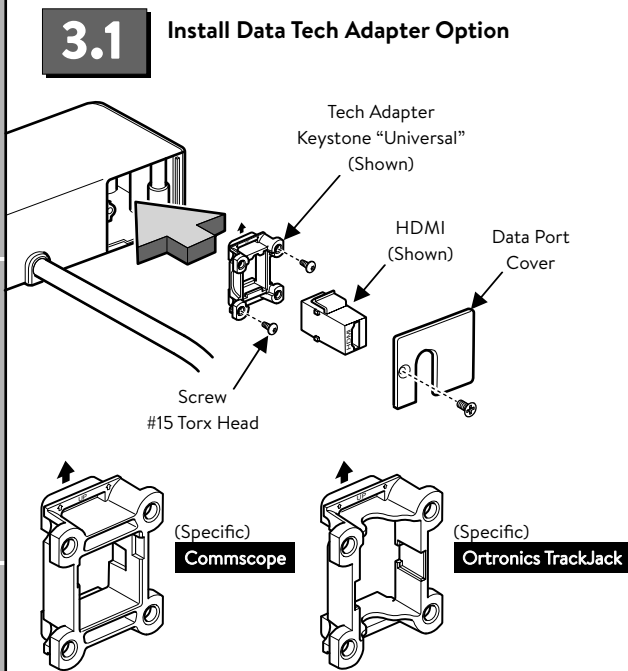

(Universal)

### KEYSTONE

HDMI	Optical Cable Corp 5e
Tripp-Lite	Optical Cable Corp 6
Allen-Tel	Ortronics
AMP TE-Krone	Panduit NetKey
Belden KeyConnect	Hubbell Premise
Leviton Quick Port	Type F Coax
Leviton Quick Port Extreme	ETC. (ET. AL.)

### 3.2 A Install VGA Connector to VGA Tech Adapters

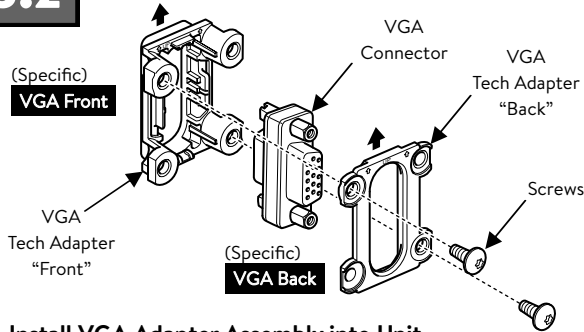

### 3.3 Install Blank Tech Adapter Option

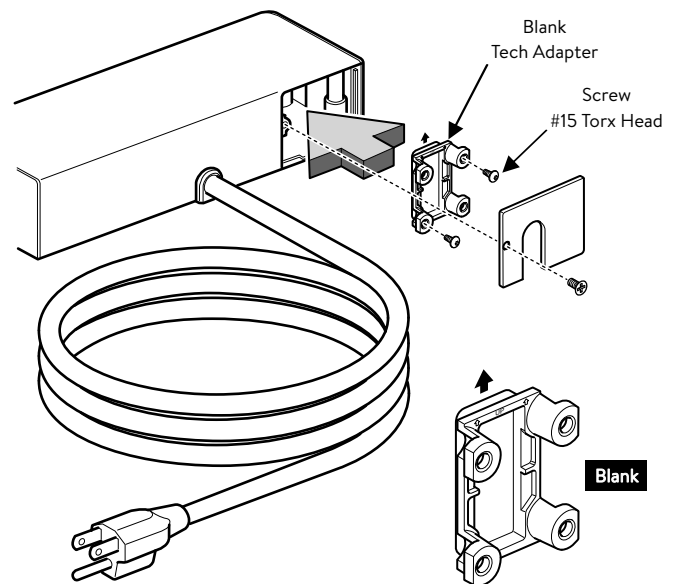

### B Install VGA Adapter Assembly into Unit

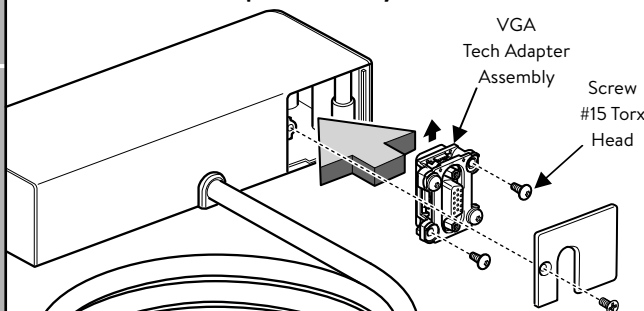

# Knoll

Knoll Systems  
Installation Instructions

## TABLE POWER CENTER OUTLET

311  
- Corded -  
Instruction Number: 6TP00534

This device complies with part 15A of the FCC Rules. Operation is subject to the following two conditions: (1) This device may not cause harmful interference, and (2) this device must accept any interference received, including interference that may cause undesired operation.

Tools Required



### 5 Table Power Center Outlet 311 Placement Dimensions

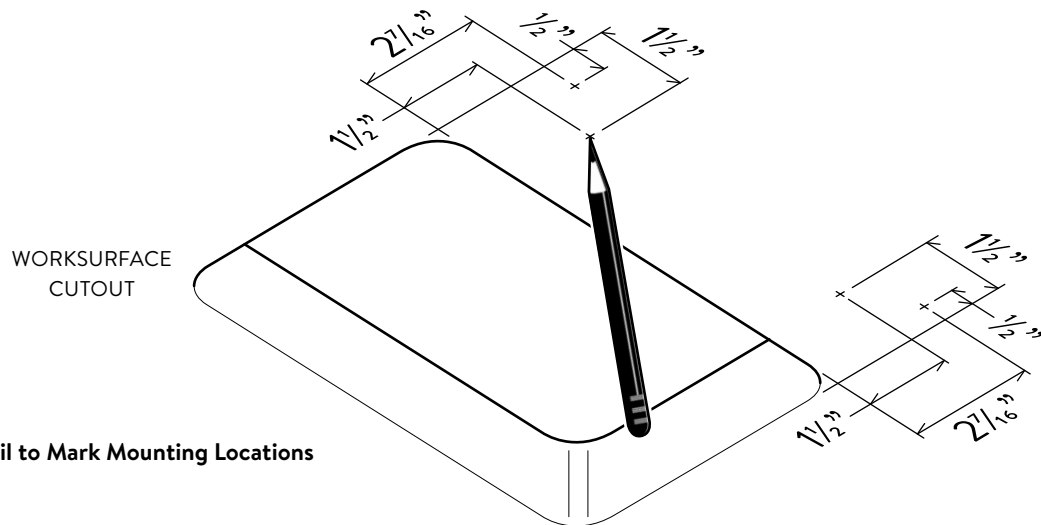

**\*NOTE\***  
Use Pencil to Mark Mounting Locations

### 6 Install Table Power Center Outlet 311 Assembly to Bottom side of Worksurface

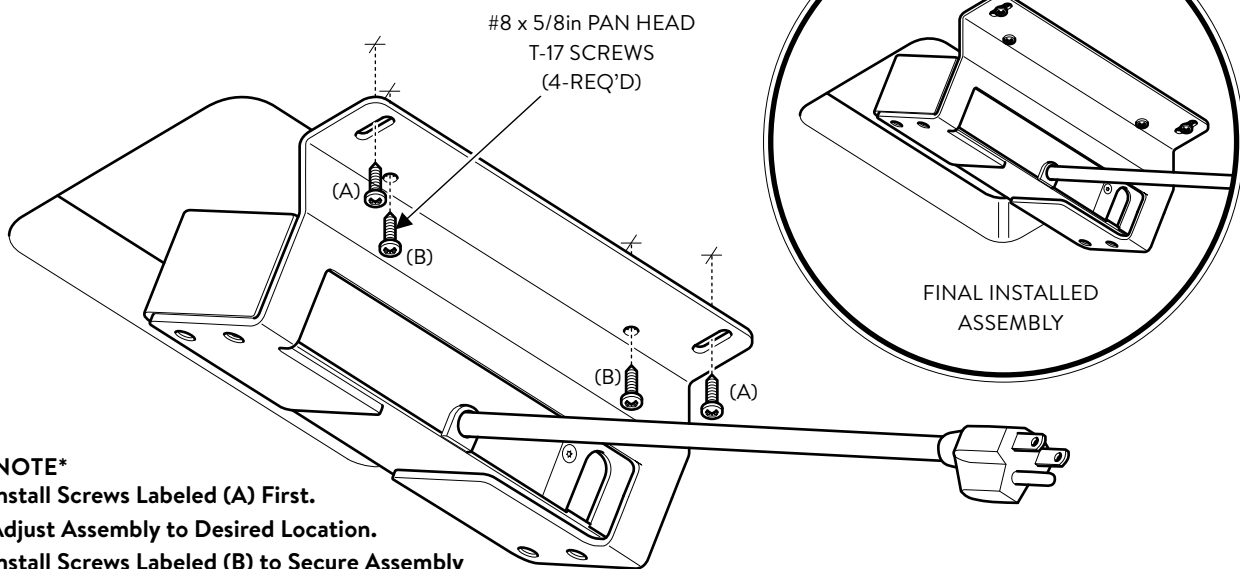

**\*NOTE\***  
Install Screws Labeled (A) First.  
Adjust Assembly to Desired Location.  
Install Screws Labeled (B) to Secure Assembly