



Knoll Systems  
Installation Instructions

# CLAMP-ON OUTLET, OFFSET

210

- Conduit -

Instruction Number: 6TP00536, 2MA3011

This device complies with part 15A of the FCC Rules. Operation is subject to the following two conditions: (1) This device may not cause harmful interference, and (2) this device must accept any interference received, including interference that may cause undesired operation.

Tools Required

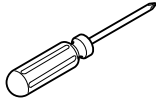

Screwdriver needed for optional power cord mounting clamps.

## 1 Slide Bracket Behind Worksurface

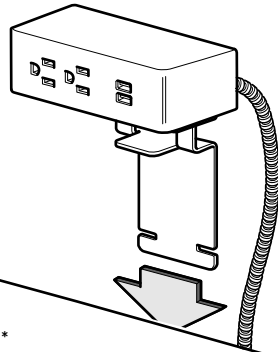

\* Top of Worksurface \*

## 2 Install Bottom Bracket Under the Worksurface

\* Underside of Worksurface \*

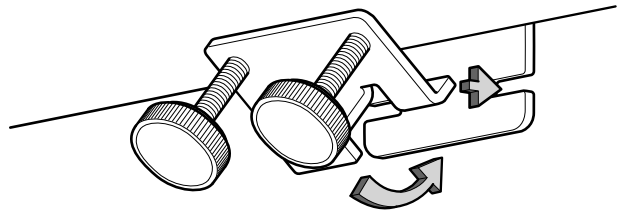

## 3 Secure Thumb Screws and Route Conduit to Nearest Power Distribution Source

\* Underside of Worksurface \*

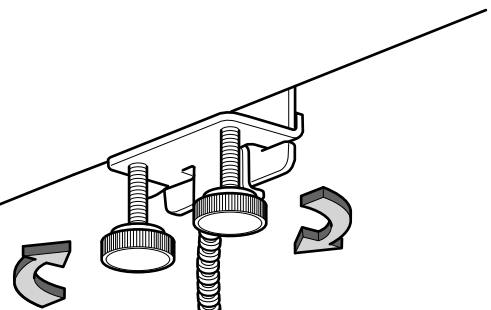

Worksurface  
Thickness Range  
(3/4" to 1-1/2")

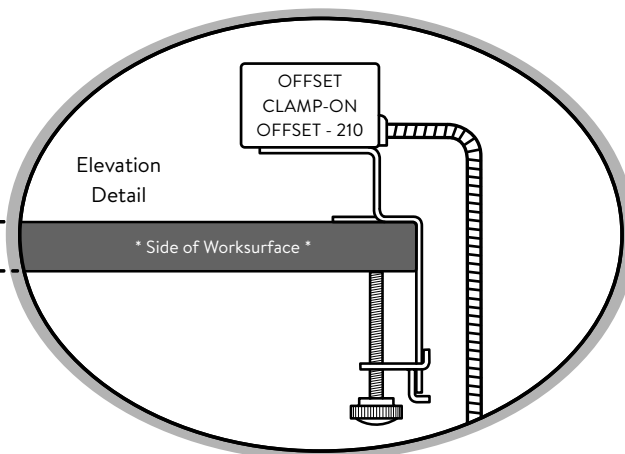
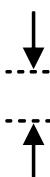

Conduit  
Feed

### WIRE IDENTIFICATION

- LINE (BLACK)
- GROUND (GREEN)
- NEUTRAL (WHITE)