



Knoll Systems
Installation Instructions

CLAMP-ON OUTLET, OFFSET

412

- Conduit -

Instruction Number: 6TP00538, 2MA3014

This device complies with part 15A of the FCC Rules. Operation is subject to the following two conditions: (1) This device may not cause harmful interference, and (2) this device must accept any interference received, including interference that may cause undesired operation.

Tools Required



#15 Torx
Screw Driver or Wrench

NOTE

All Tech Adapters Need to be Mounted in the
⬆ "UP" ⬆ Position. (Refer to the back of Parts)

1 Remove Data Port Cover and Blank Adapters

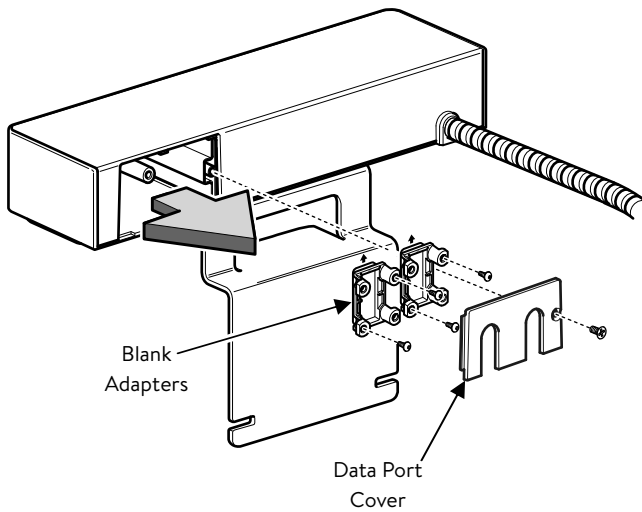

2 Install Data Port Options (VGA, RJ45, HDMI, BLANK)

NOTE

See Sheet #2 for Detailed Instructions

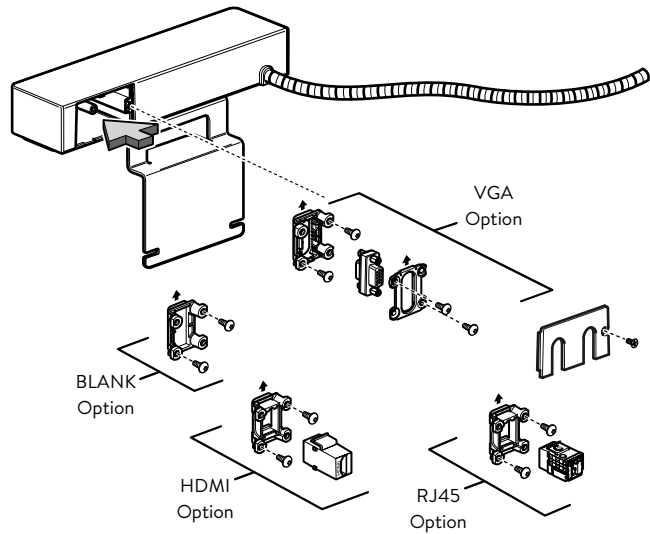

3 Slide Bracket Behind Worksurface

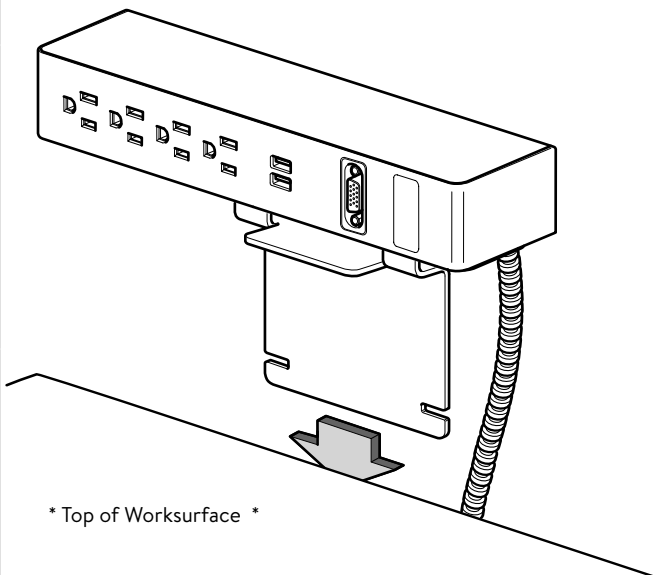

4 Install Bottom Bracket Under the Worksurface

* Underside of Worksurface *

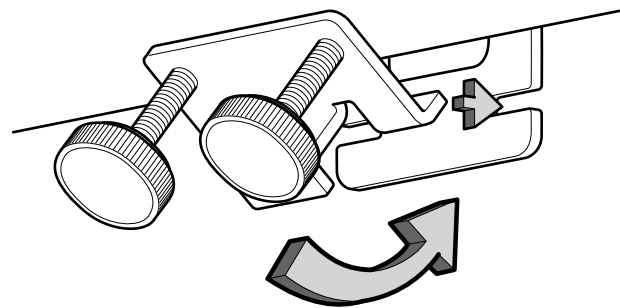



Knoll Systems
Installation Instructions

CLAMP-ON OUTLET, OFFSET

412

- Conduit -

Instruction Number: 6TP00538, 2MA3014

This device complies with part 15A of the FCC Rules. Operation is subject to the following two conditions: (1) This device may not cause harmful interference, and (2) this device must accept any interference received, including interference that may cause undesired operation.

Tools Required



NOTE

All Tech Adapters Need to be Mounted in the
⬆ "UP" ⬆ Position. (Refer to the back of Parts)

2.1 Install Data Tech Adapter Option

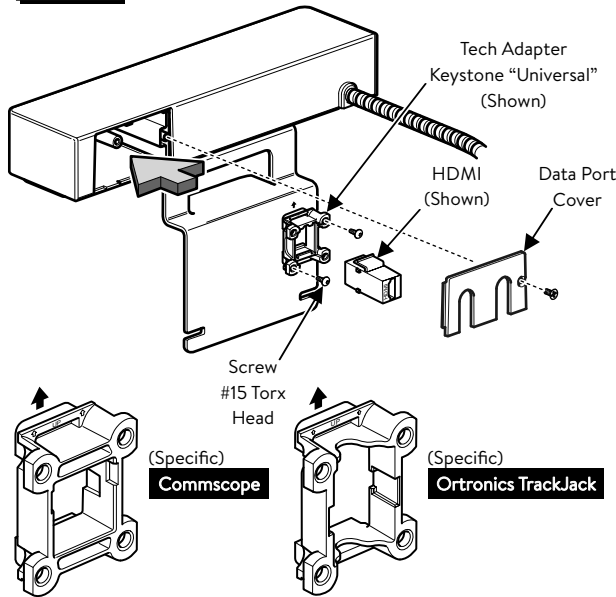

(Universal)

KEYSTONE

HDMI	Optical Cable Corp 5e
Tripp-Lite	Optical Cable Corp 6
Allen-Tel	Ortronics
AMP TE-Krone	Panduit NetKey
Belden KeyConnect	Hubbell Premise
Leviton Quick Port	Type F Coax
Leviton Quick Port Extreme	ETC. (ET. AL.)

2.2 A Install VGA Connector to VGA Tech Adapters

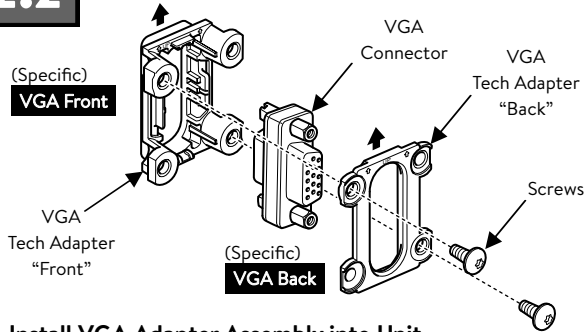

B Install VGA Adapter Assembly into Unit

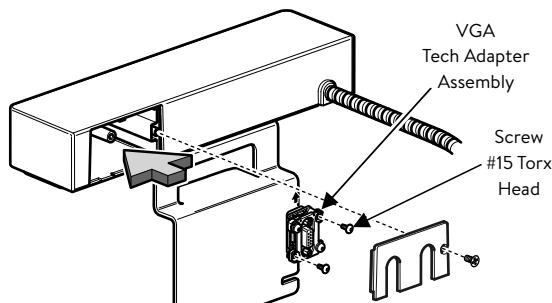

2.3 Install Blank Tech Adapter Option

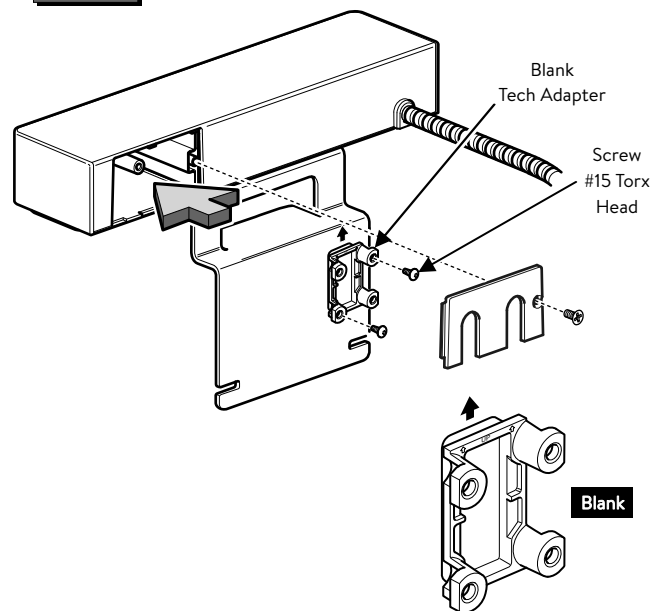



Knoll Systems
Installation Instructions

CLAMP-ON OUTLET, OFFSET

412

- Conduit -

Instruction Number: 6TP00538, 2MA3014

This device complies with part 15A of the FCC Rules. Operation is subject to the following two conditions: (1) This device may not cause harmful interference, and (2) this device must accept any interference received, including interference that may cause undesired operation.

Tools Required

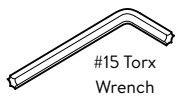

#15 Torx
Wrench

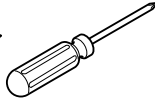

Screwdriver needed for optional
power cord mounting clamps.

5

Secure Thumb Screws and Route Conduit to Nearest Power Distribution Source

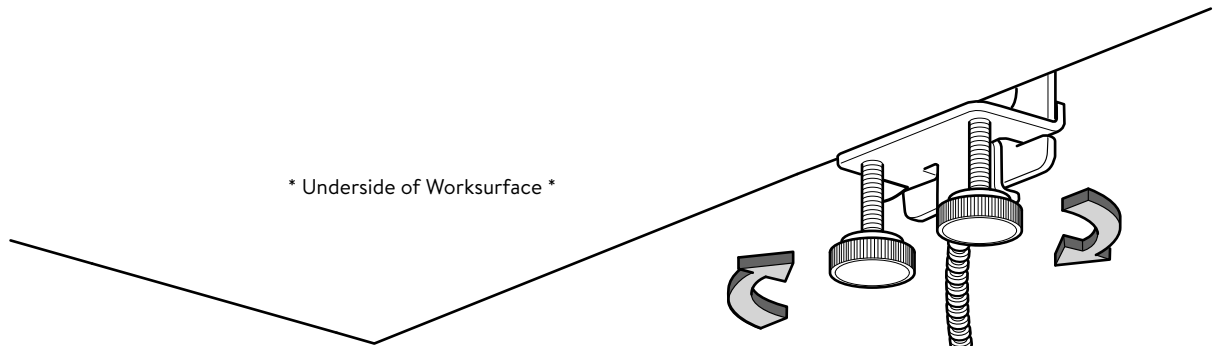

Worksurface
Thickness Range
(3/4" to 1-1/2")

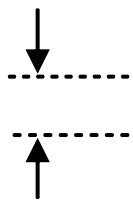

Elevation
Detail

* Side of Worksurface *

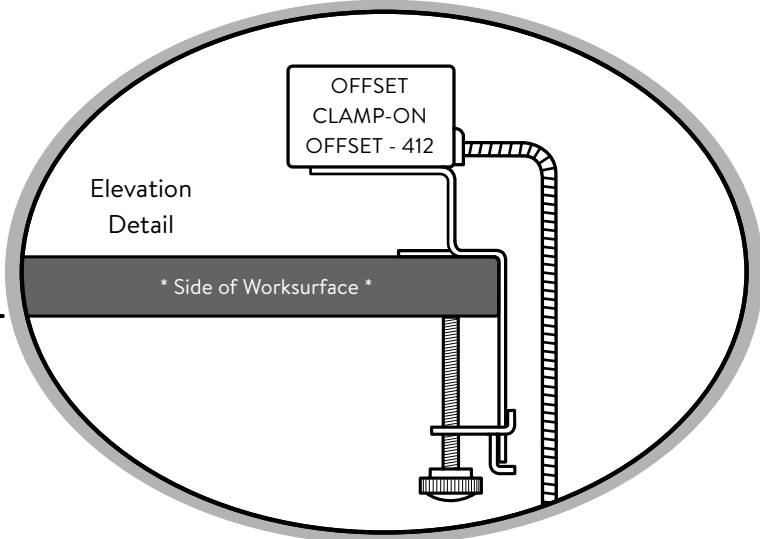

Conduit
Feed

WIRE IDENTIFICATION

- LINE (BLACK)
- GROUND (GREEN)
- NEUTRAL (WHITE)