

LSM Tables - Core drill hole specifications

48" Deep

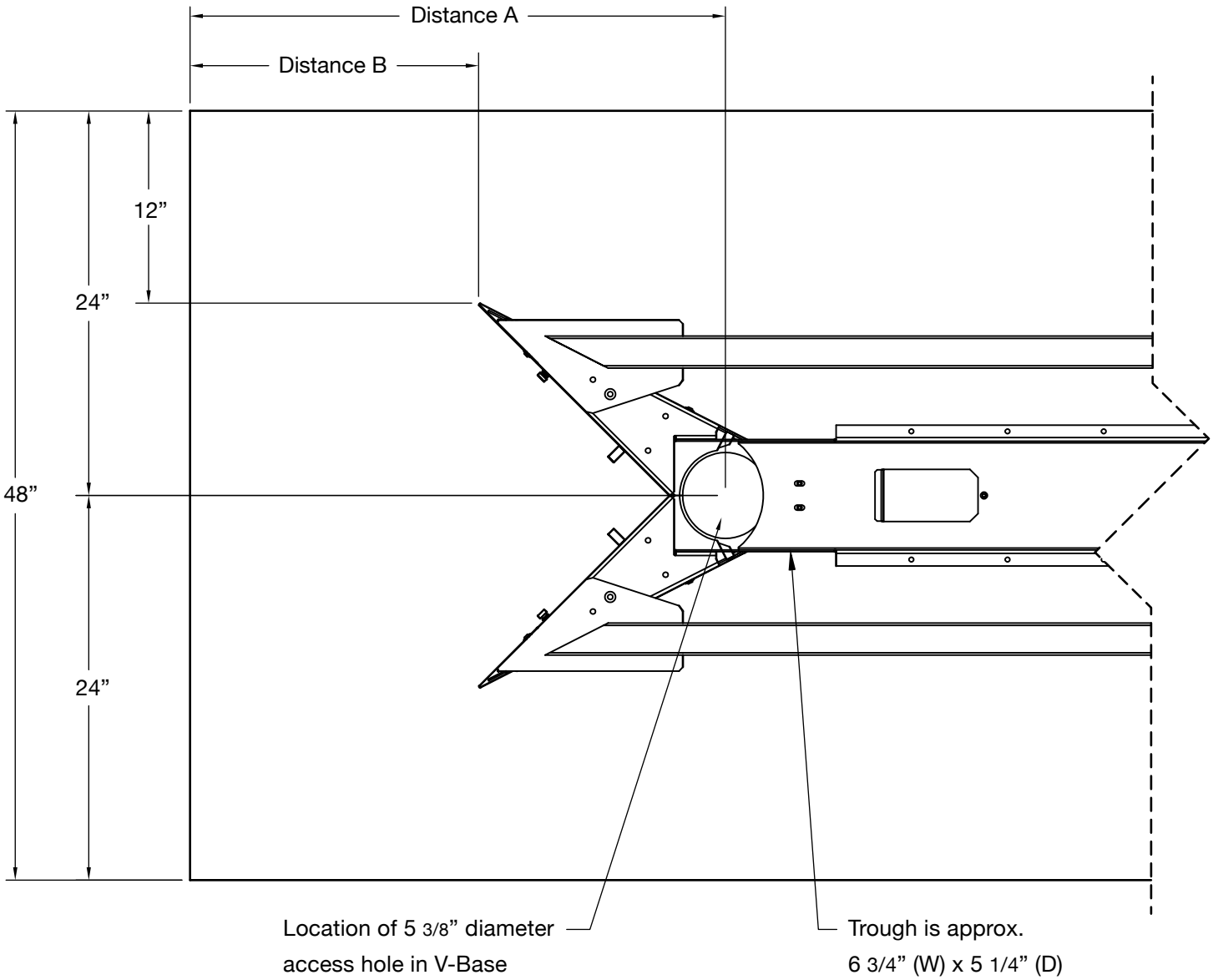

Pattern #:	Table size:	Distance A:	Distance B:
L3-RV04	96" x 48"	29 13/16"	14 3/8"
L3-SV22	120" x 48"	33 3/8"	18"
L3-SV24	144" x 48"	33 3/8"	18"
L3-TV36	192" x 48"	33 3/8"	18"
L3-TV60	240" x 48"	33 3/8"	18"
L3-TV62	288" x 48"	33 3/8"	18"