

Credenza And Doublewide Pedestal

Note: Counterweights are always mounted behind a drawer. Up to (2) counterweights can be stacked in one opening.

1. Open bottom file drawer and remove from unit.
2. Place counterweight against back of unit and sitting flush on base. Approximately center counterweight in the drawer opening. **Note:** When multiple counterweights are required, stack weights together and place against back of unit.
3. Drive 1/4-14 x 7/8" screw into back panel through slot in center of counterweight.
4. Replace file drawer back into unit.

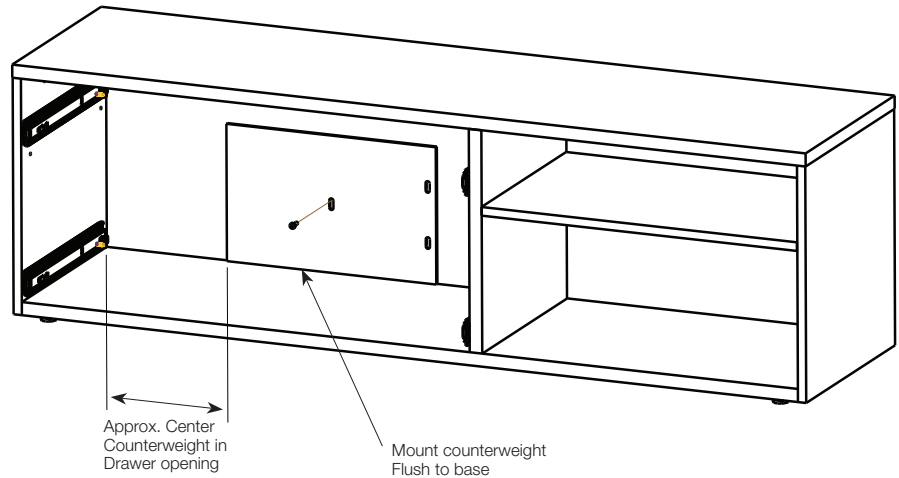

Anchor Locker Counterweight

1. Place a non-marring support on the floor behind unit and lay unit on its back on the support. (Fig. 1)
2. Align (2) holes on counterweight with holes on underside of base. **Note:** To aid in holding counterweight in place for attachment, place counterweight on edge of raised feet if present. If unit does not have feet, a 4" block of rigid material may be placed against the base to aid in holding counterweight up while attaching. (Fig. 1)
3. Drive (2) screws into counterweight holes. (Fig. 1)
- 4 Rotate unit back to upright position.

