

# Y-Leg Folding Tables

Casters only

Related tables:  
KYDW9648C

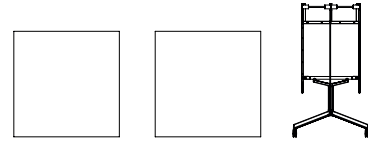

## Unboxing

You should have received two boxes per table.

### Box 1 includes:

Leg assembly, with hardware in a red plastic bag, and installation instructions.

### Box 2 includes:

Table tops

## Parts list

- 2 Table tops
- 1 Leg assembly

## Hardware

- 10 1/4" - 20 x 1.5" socket head cap screws
- 14 1/4" - 20 x 2" Button head socket drive screws

## Tools needed

- Allen wrench

## Step 1

Line up the two inverted tops next to each other on the floor.

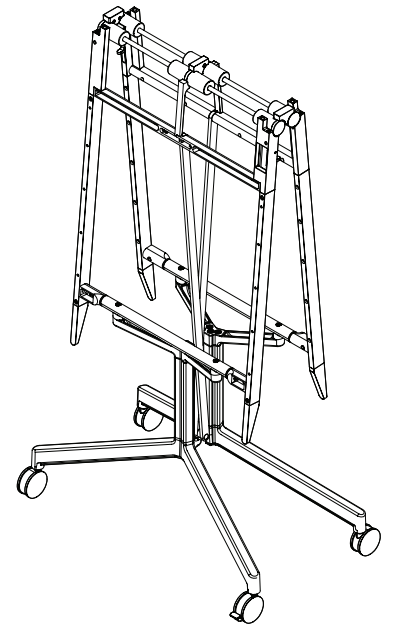
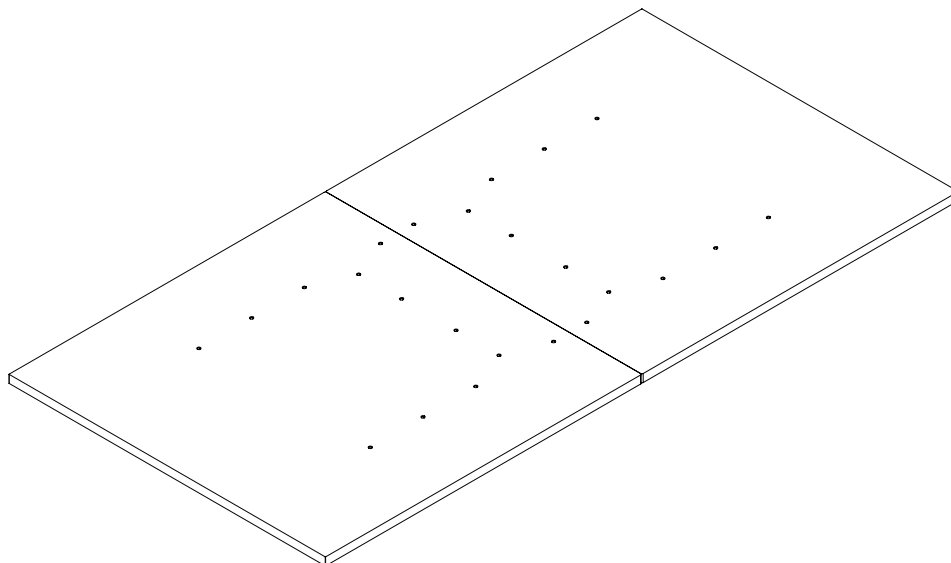
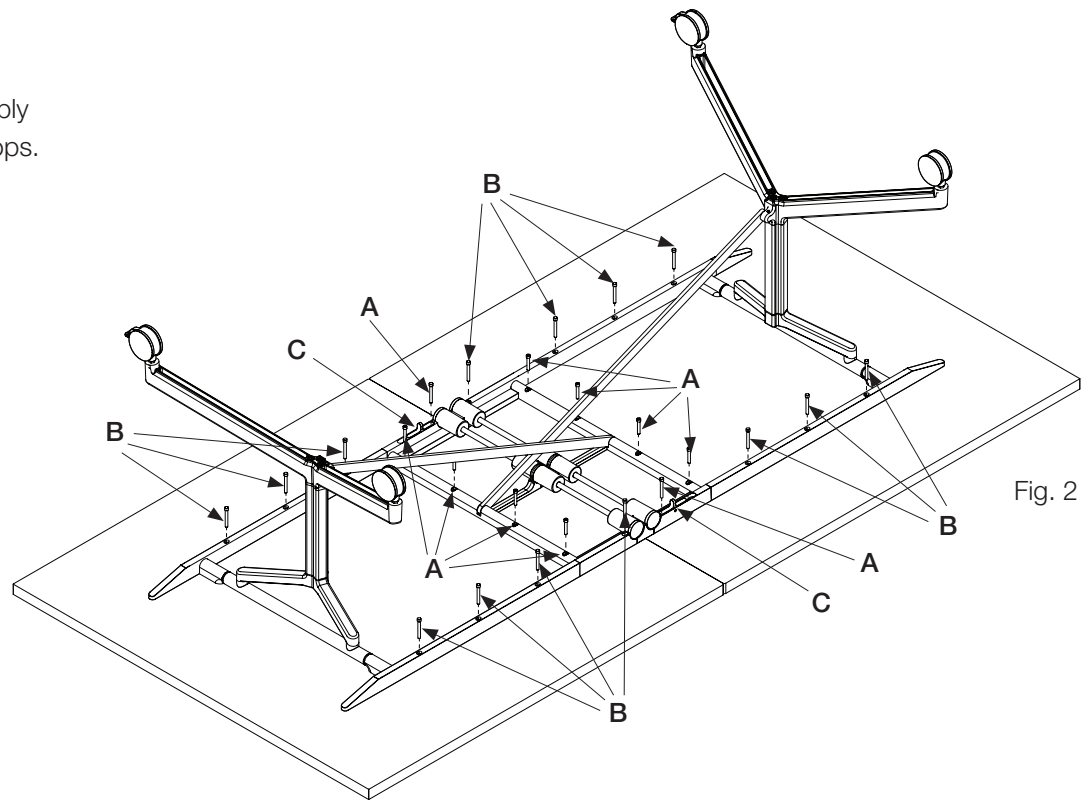

Fig. 1

# Y-Leg Folding Tables

## Step 2

Place the inverted base assembly on the underside of the table tops.



## Step 3

Align and attach the base with the threaded inserts in the top.

Use 1/4" - 20 x 1.5" socket head cap screws (A), 10 per base. Please note that 2 of these screws are covered by the sliding lock.

Use 1/4" - 20 x 2" Button head socket drive screws (B), 14 per base. Use 5/32" Allen wrench, torque: >100 in/lb.

Ensure locking mechanisms are functioning by sliding red lock handles (C) to the left and right.

