

Pixel S Series Flip-top Tables

Casters

Related tables:

KLCPW6024

KLCPW6030

Box 1 includes: Table top

Box 2 includes: Leg assemblies, hardware

Box 3 includes: Stiffener, cross member

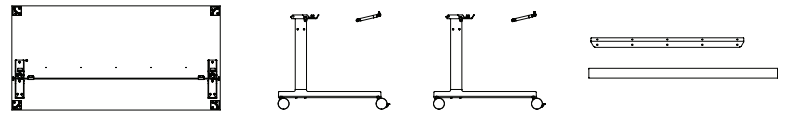

Parts list

- 1 Table top
- 1 Left leg assembly
- 1 Right leg assembly
- 1 Cross member
- 2 Plastic end caps
- 1 Stiffener
- 2 Vertical wire management clips (clear plastic)

Hardware

- 5 #14 x 3/4 Sheet metal screws
- 2 Gas cylinders - 30" table
- 2 Ball studs, lock washers - 30" table (24" Tables require 1 gas cylinder, ball stud, lock washer)

Hardware pre-attached to top assembly

- 2 Hinge pins
- 2 E-clip retaining rings

Tools needed

Phillips screwdriver, Allen wrench

Step 1.

Invert the table top.

Attach the stiffener (A) to the underside of the top using 5 #14 x 3/4 Sheet metal screws (B).

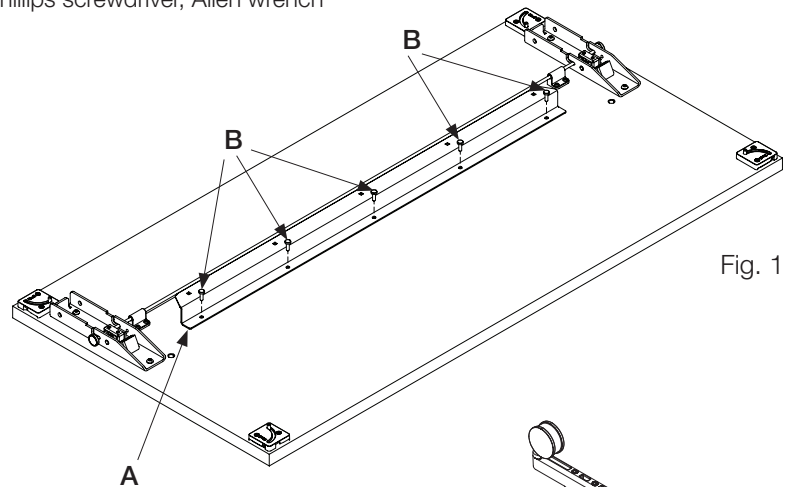

Fig. 1

Step 2.

To attach the cross member (C) between the two legs, use the 3/8" – 16 x 2.00 low profile head cap screws (D) that are already inserted through each leg, do not remove these screws. Remove the plastic screw covers (retainers), then fasten to the cross member.

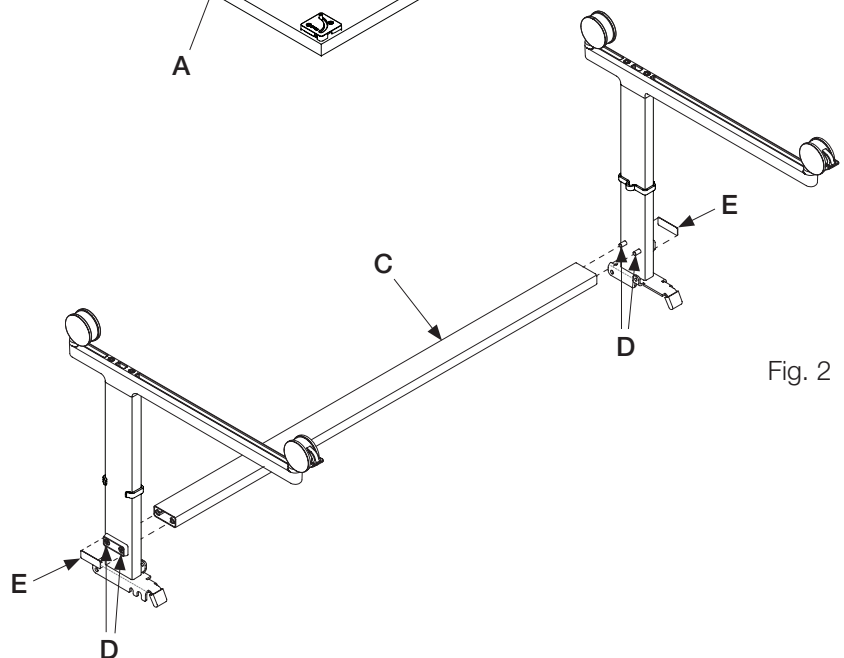

Fig. 2

Step 3.

After attaching the cross member, snap the plastic end caps (E) into position, to cover the cross member screws.

Pixel S Series Flip-top Tables

Casters

Step 4.

Remove the hinge pins (H) from the leg assembly by removing the E-clip retaining ring (I), shown in Fig 4.

Position the leg assembly (F) on the top so that the pin holes in the leg assembly top plate align with the holes in the hinge bracket (G) on the underside of the top.

Attach each leg to the top with hinge pin (H). Slide each hinge pin through the hinge bracket and leg top plate from the outside of the leg.

If the leg brackets and top brackets do not align perfectly (if the distance between the brackets is too wide or narrow), loosen the leg bracket's 3/8 - 16 x 1.50 socket head screws; then slide the leg bracket to the optimum position (center of the top brackets), then tighten the screws again.

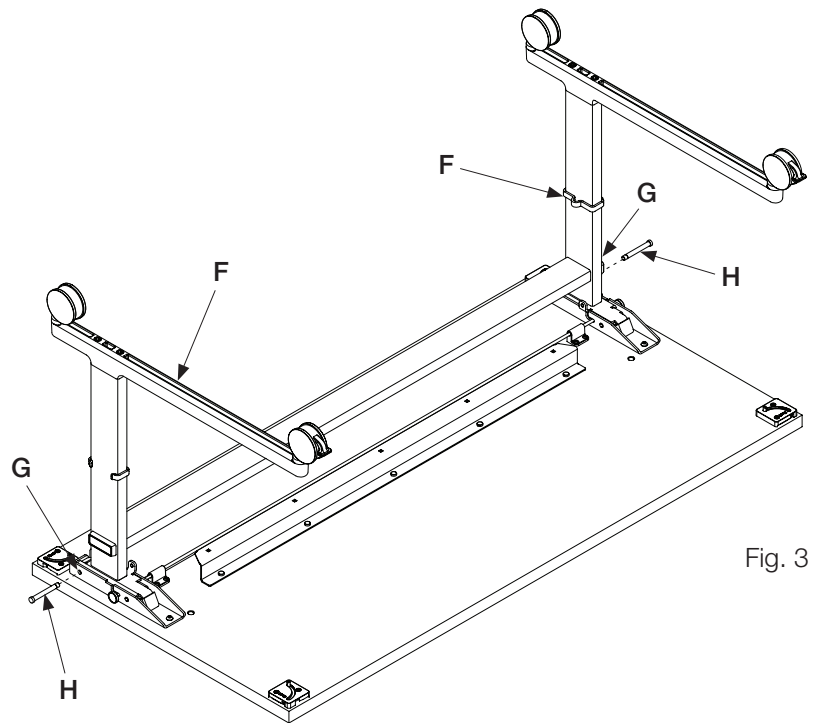

Fig. 3

Step 5.

Fasten the pins on the inside of the leg with the E-clip retaining ring (I).

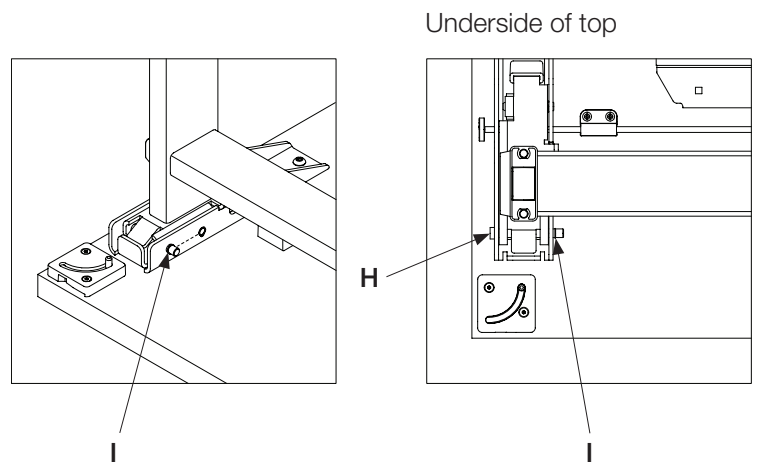

Fig. 4

Fig. 5

Pixel S Series Flip-top Tables

Casters

Step 6.

Attach the ball studs (K) to the underside of the top. Snap the 2 gas cylinders* to the leg assembly bracket (J), and to the ball studs.

*Gas cylinders:

30" x 60" tables require (2x) 350N cylinders,
(part#: 1C59603)

24" x 60" tables require (1x) 400N cylinder.
(part#: 4AU3145)

All tables come with 2 vertical wire management clips (L). See separate electrical installation instructions for details.

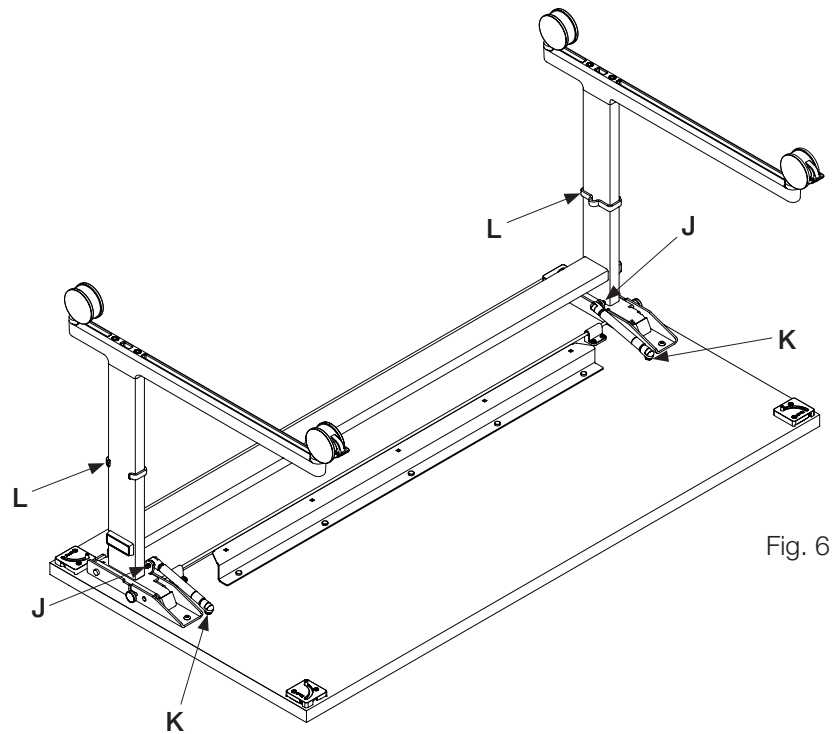

Fig. 6