

# Credenza Spacer

## For Anchor, Quion and Template

### Hardware

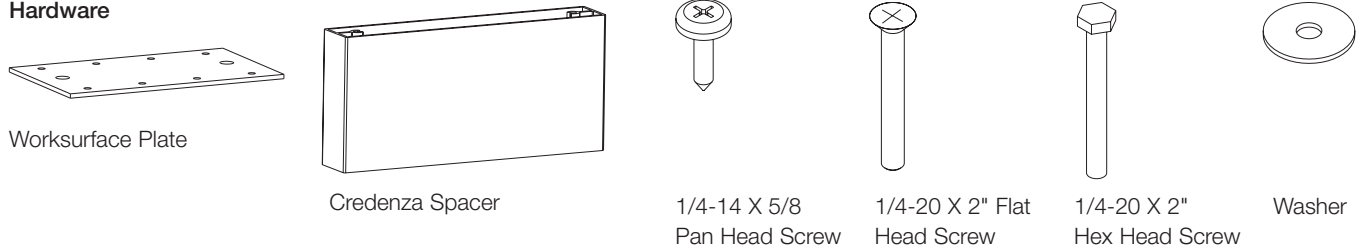

### Steps

*Note: When using with Series 2 or Quion credenza, reposition 2 front levelers into PEM nuts in recessed channel prior to mounting credenza spacer.*

1. Line up edges of worksurface and credenza top.
2. Center spacer bracket on credenza top as shown (Fig. 1)
3. Using plate as a guide, drill (2) 9/32" diameter holes thru credenza top. (Fig. 2)
4. Attach plate to spacer using 1/4-20 x 2" flat head screws.
5. Attach plate assembly to worksurface top using 1/4-14 x 5/8 pan head screws. (Fig. 3)
6. Attach plate assembly to credenza using washers and 1/4-20 x 2" hex head screws.
7. Attach opposing end of worksurface to desk supporting storage or Dividends Horizon leg or worksurface support as applicable.

Fig. 1

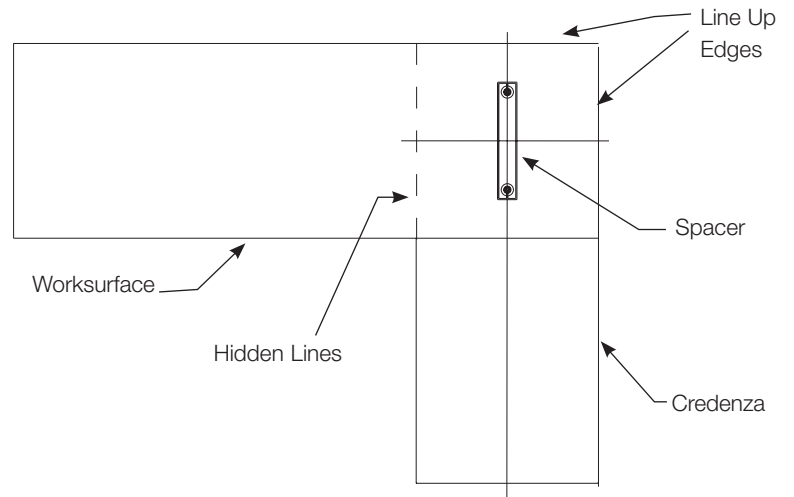

Fig. 2

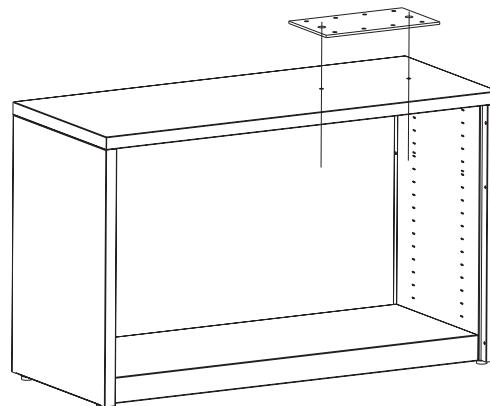

Fig. 3

