

k. Screen Extend, Metal

1. Prepare

Clean worksurface with 50:50 IPA and water mixture and allow to completely dry to ensure best adhesion of the VHB attachments on the bottom of the screens.

2. Unpack

Remove all pieces of the surround from shipping boxes. Hardware kits may ship in a separate box from the screen.

3. Install Mounting Brackets to the Screen

- + Flip the corner pieces upside down and pre-install the u-channel shaped mounting brackets to the bottom of the screen. (**Fig. 1**)
- + If shims are included in your packing, install the shims on the outside of the screen into the mounting bracket
- + Install the provided set screws – 2 per mounting bracket, using a 1/16" hex key (note: the set screws do not bottom out and should sit flush on both faces of the mounting bracket when installed)

4. Dry fit the corners

Position and align the 2 corners with the brackets pre-installed on the work surface, without removing the VHB tape backing. The distance from the edge of the work surface to the edge of the mounting bracket should be 5/16" along the rear and along the sides. This accommodates a range of work surface corner radii. (**Fig. 2**)

5. Remove VHB backing and set the corner screens

- + For the first corner– lift one leg of the corner while leaving the other leg of the corner set on the worksurface to keep the alignment. (**Fig. 3**)
- + Remove the VHB backing
- + Place the corner back onto the worksurface while maintaining the initial alignment to the edge.
- + Repeat this process for the other leg of the first corner (**Fig. 4**)
- + Once the first corner is completely installed, apply downward pressure over each mounting bracket for 10 seconds to ensure the VHB tape has a full bond.
- + Repeat for the second corner.

7. Install the center panel

The center panel gets hung over the two corners and centered along the length of the worksurface. (**Fig. 5**)

Fig. 1

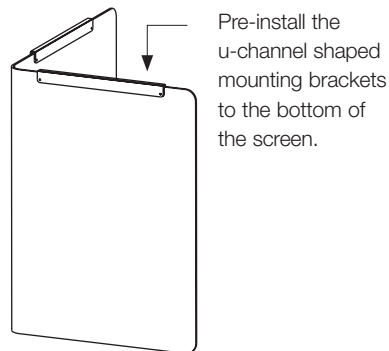

Fig. 2

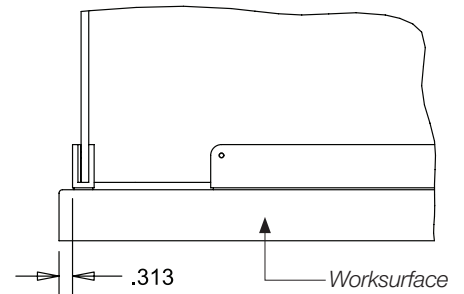

Fig. 3

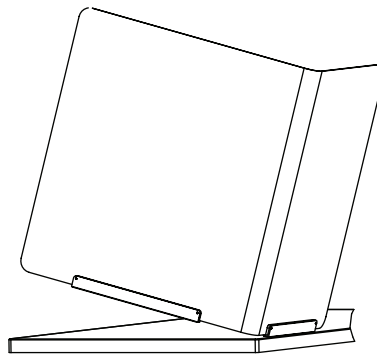

Fig. 4

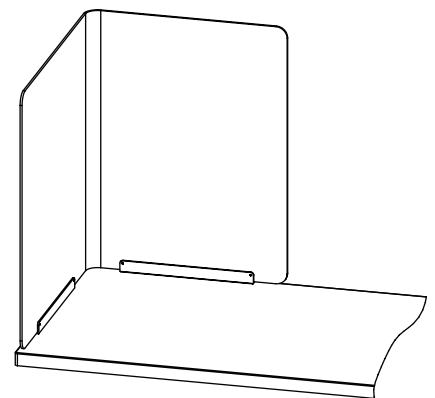

Fig. 5

