

# Wide Grommet

Reference Number: 6TD00064

## Tools Needed

Drill gun

HARDWARE LIST						
(A)	(B)	(C)	(D)	(E)	(F)	(G)
6TD40165 SCR, FLT#6-32x0.875	6TD40157 COVER HINGE PIN	6TD40148 SCR, THUMB, 10-24x0.500	6TD00016XX WIDE GROMMET ASSEMBLY	6TD40154XX CONNECTOR RAIL	6TD00028 BRIDGE ASSEMBLY	6TD40153XX WIDE GROMMET COVER

## STEPS:

### 1. Assembly of cover frame

- 1.1 Align the connector rails (E), with one of bridge assembly (F), and secure into place using 1 screw (A) for each rail, ensure correct orientation of connector rail as per Fig. 1.
- 1.2 Align the other ends of connector rails (E), with second bridge assembly (F), and secure into place using 1 screw (A) for each rail.  
(Fig. 2)
- 1.3 Align & assemble 4 thumbscrews (C), into bridge support of bridge assembly (F), ensure threads do not extend beyond exit whole edge.  
(Fig. 3)

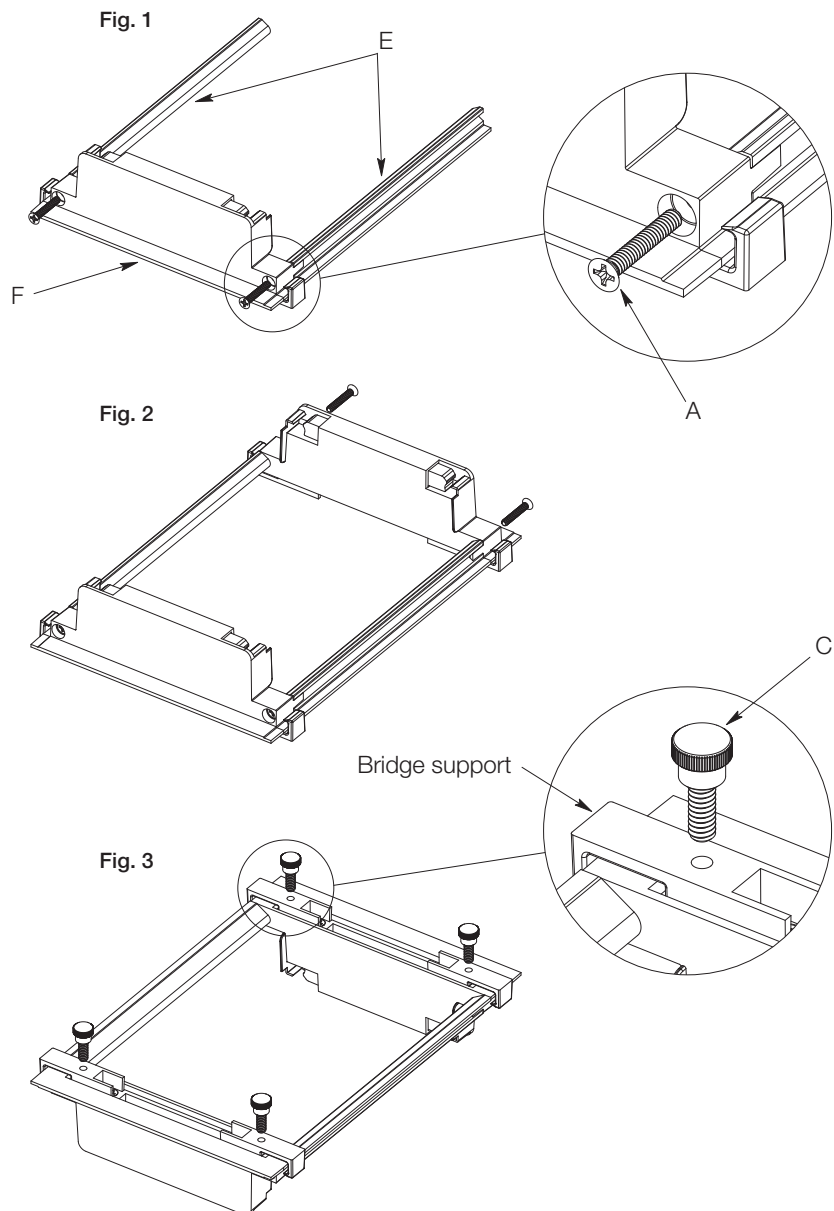

## Wide Grommet

Reference Number: 6TD00064

### 2. Assembly of cover frame with grommet assembly

- 2.1 Insert upward the assembled cover frame into wide grommet assembly (D). (Fig. 4)
- 2.2 Position cover frame by moving side to side into grommet assembly and secure it by tightening thumb screws (C), ensure bridge support are engaged with side rails. (Fig. 5)

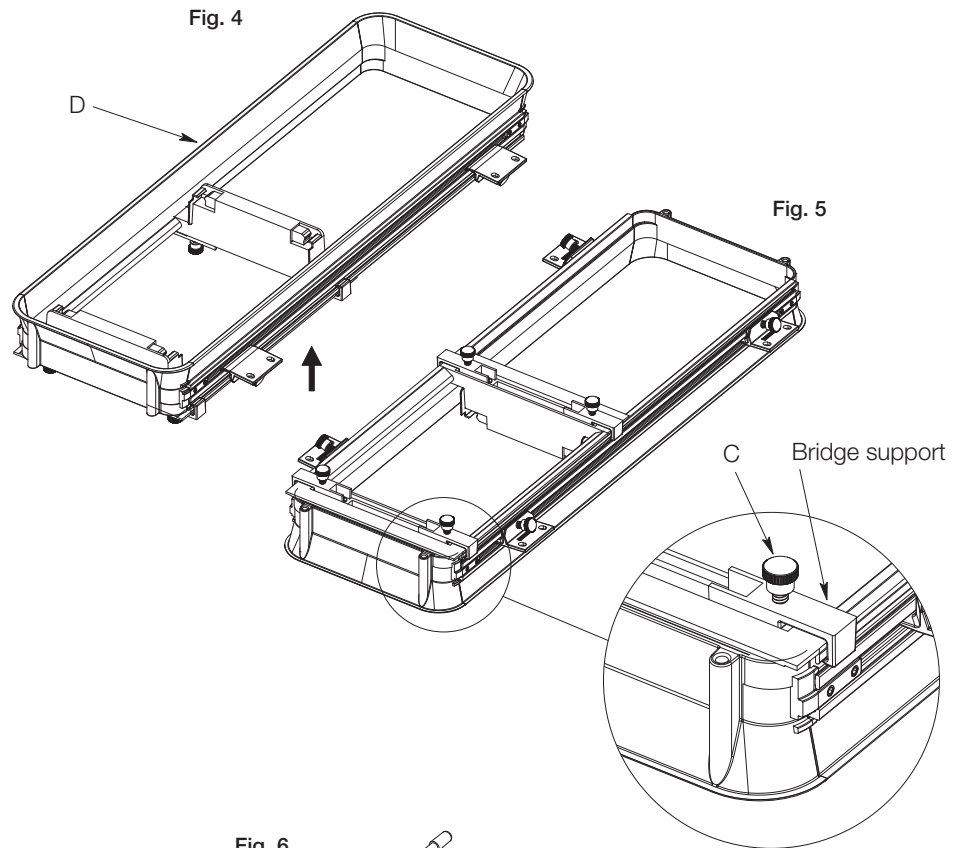

### 3. Assembly of cover

- 3.1 Align and insert 4 cover hinge pins (B), into holes of grommet cover (G). (Fig. 6)

### 4. Assembly of cover with assembled grommet

- 4.1 Align all 4 cover hinge pins (B), of cover assembly with spring loaded bridge plungers, and gently push down to make sure hinge pins are engaged with bridge plungers. (Fig. 7)

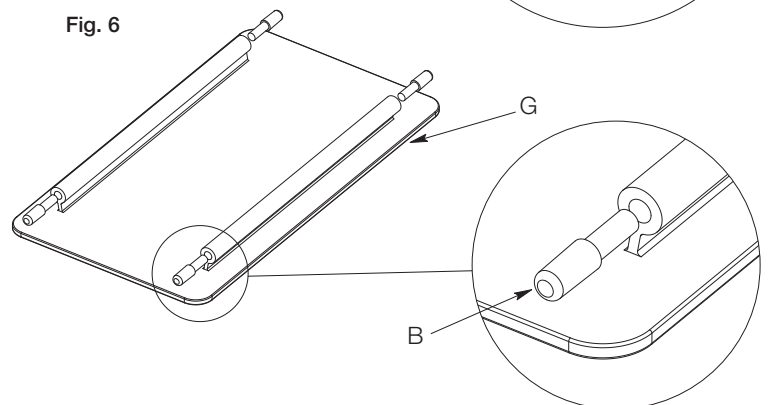

Repeat all above steps to assemble all remaining wide grommets.

Complete Assembled Wide Grommet

