

Chadwick™

**smart
comfortable
easy
accessible
just right**

Knoll

Product
Guide



Chadwick™



contents

02 smart

08 comfortable

12 easy

16 accessible

21 just right

22 more info

smart

Don Chadwick created a chair that embodies the best of his thinking with the finest principles of Knoll design.



Don Chadwick
has created an intelligent
chair for a smarter world.

Design

Don Chadwick has created an intelligent chair for a smarter world. Don designed the Chadwick chair to go beyond expectations in work seating. With an eye toward precision, he has removed complicated adjustments, keeping only the features that help people make the most of their work.

Some of the most iconic office chairs of our time have been designed by Chadwick. With 30 years of industrial design experience, he has now applied this knowledge, intuition and aesthetic sensibility to this Knoll chair.

Chadwick approached the creation of the chair with the principles of Knoll design in mind:

- To qualify as a Knoll design, a product has to be utilitarian and elegant. These elements blend in a manner that is truly contemporary, with all the promise of becoming a modern classic.
- The utilitarian aspect of the Chadwick chair is the result of Chadwick's accumulated knowledge of ergonomics, mechanisms and environmental factors. His intuitive sense of their impact on development and manufacturing was an important part of the design process.

Shapes, materials, finishes and, above all, tactile and visual cues make the chair simple and straightforward.

Concept

Don Chadwick conceived the chair to embody the best of his thinking and the principles of Knoll design.

His concept focuses on the features and functionality of a chair for dual use, consolidating the nature of work chairs and conference/training chairs.

The dual nature of the Chadwick chair is a new hybrid class of seating for Knoll that accommodates the changing needs of offices.

Research shows that chair requirements are changing. Chairs have more purposes, moving from the individual workstation to the group work area, demonstrating a shift in clients' needs.

Today, office planning is organized with 80% of the chairs for workstation use, while 20% are utilized for collaborative spaces. Over the next five years, the expected combination will shift to 60% workstation use and 40% collaborative use (Source: Knoll Workplace Research Benchmarking Studies, 2004).

Chadwick meets the needs of the changing office.

- As a work chair, Chadwick is ready to perform.
- As a conference or training chair, Chadwick is space-efficient and comfortable.

Overall, Chadwick is versatile, moving from work area to conference room. It reflects the evolutionary nature of Don Chadwick's design process: rethinking, redefining and refining the experience of sitting.

Innovation

Chadwick is a testament to innovative design and engineering. His efficient use of materials results in a chair that is easy to assemble, simple to use, durable and stylish.

Efficient Use of Materials

Chadwick's principal components are light injection-molded forms that make up the frame, arms and base. Their size and shape contribute to the reduction in the overall number of parts required to assemble Chadwick chairs. The components' strength is optimized by the hollow air shaft that is blown into the parts using a "gas-assist technology" during the injection molding process. This makes the chair more visually exciting, while enhancing its strength and durability. The reduced dependency on materials is also environmentally smart.

State-of-the-Art Assembly

Chadwick's principal components are linked in six locations for ease of assembly. This engineering foresight resulted in tremendous efficiency of labor and parts that contributes to the cost competitiveness of the chair.

Environment

Chadwick provides solutions that contribute to earning LEED® credits. Environmental aspects were incorporated into the Chadwick chair early in the design process. Knoll utilized its Environmental Design Guide to minimize negative environmental impact throughout the chair's life cycle. The result of this approach is a chair that uses technologies such as integral coloring on plastic components and zero VOC (volatile organic compound) paints.

Raw materials with a recycled content of 41% are used. The chair is designed for durability and ease of disassembly so that parts can be removed and replaced effortlessly. As a result of material selection and clean manufacturing practices, Chadwick is GREENGUARD™ certified.

Depending on your project parameters, the Chadwick chair can help achieve the following LEED® credits:

New Construction – Chadwick offers two material resource credits for recycled content and two possible innovation credits, namely GREENGUARD™ certification and a possible location credit. Also, two potential credits could be available in the future when the chair is refurbished.

Commercial Interiors – Chadwick offers two material resource credits for recycled content, one indoor air quality credit for GREENGUARD™ certification and a possible location credit. Also one potential credit could be available in the future when the chair is refurbished.

Existing Building – Chadwick offers one material resource credit for recycled content and a possible innovation credit with GREENGUARD™ certification.

Just Right.

Chadwick is a handsome, athletic chair designed to leverage the best of Don Chadwick and the best of Knoll.

One chair. Multiple functions. Perfect for working, meeting or training. Chadwick creates a new definition in affordable seating.



As a work chair, Chadwick is easy to use.



As a conference/training chair, Chadwick is space-efficient and comfortable.



comfortable

**All-inclusive, built-in
comfort takes on new
meaning with Chadwick.
Stay awhile.**

Active Suspension™

At the heart of Chadwick's
comfort is Active Suspension™,
offering resilient support.



All-inclusive, built-in comfort means that the Chadwick user is unconsciously aware of the support features designed into the chair, yet receives all the benefits.

Active Suspension™ System

At the heart of Chadwick's comfort is Active Suspension™, offering resilient support similar to that of riding a mountain bike, running in a well-designed training shoe or jumping on a trampoline.

Active Suspension™ makes Chadwick feel energizing and resilient because the chair's control works in tandem with the proprietary suspension fabric on the seat and back. The result is a supported ride that enhances the sitting experience.

Chadwick's Active Suspension™ system consists of two parts:

1. The Synchronized Tilt Mechanism

The synchronized tilt mechanism creates a natural recline. It has been proven to be one of the most comfortable chairs in Knoll user "sit tests" when compared with other leading chairs. To optimize comfort, the tension should be customized to each user. The tension knob should be adjusted to balance the desired working posture. (For more detail see page 15.) The recline's natural movement from one position to the next is the result of the control geometry, a synchronized recline ratio of 1:1.2 (seat to back recline). This recline ratio provides the following benefits:

- A cradled feeling that keeps the user's lumbar in contact with the back of the chair throughout the entire recline.
- A motion that allows the user's torso to open up, promoting healthful circulation.

2. The Chadwick Fabric

The proprietary Chadwick fabric that is stretched on the seat and back of the chair is the second part of the Active Suspension™ system.

The comfortable elastomeric construction of the fabric provides energizing support. The material conforms to the user's shape and minimizes pressure points. The soft, aerated fabric also enhances comfort.



Variable Seat Depth

Another active characteristic of the Chadwick control is the variable seat depth. The seat area automatically expands 2.5" from (16.9" to 19.4") when sitting in the chair.

This is a function of the recline geometry, which helps accommodate a large range of users.

Forward Tilt

When unoccupied, Chadwick resides in a slightly forward pitch. This three-degree forward tilt is automatic and does not require any adjustment. It allows the user to unselfconsciously move into a slightly forward position while typing, which positions the user's lower back in a lordotic curve (an "S"-shaped curve.) This position gives the user stability and reduces fatigue while working.

When sitting forward in Chadwick, the user's lordotic curve mimics the curve that the back assumes while standing.

Note: Most competitive chairs require the user to specify (and pay for) an additional forward tilt feature, which also typically requires a manual adjustment.

Generous Lumbar Curvature

Chadwick features ample lumbar curvature and tension in the back suspension area. No additional lumbar pillow or attachment is necessary.

A series of Knoll blindfolded sit tests revealed that most people prefer the comfort of Chadwick without the additional lumbar.

Note: Should a user or bid specification require additional lumbar support, an optional lumbar is available.

Flexing Armpads

The Chadwick armpads are designed like a suspension bridge, resulting in armpads that flex for additional give which alleviates pressure points on the arms.

Just Right.

Chadwick optimizes the sitting experience with built-in comfort features, including Active Suspension™.

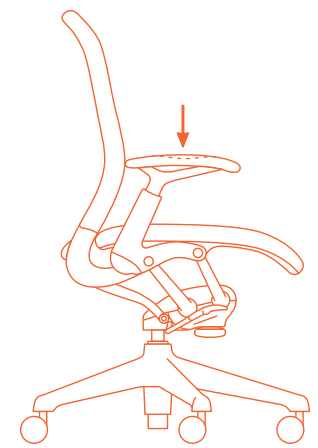
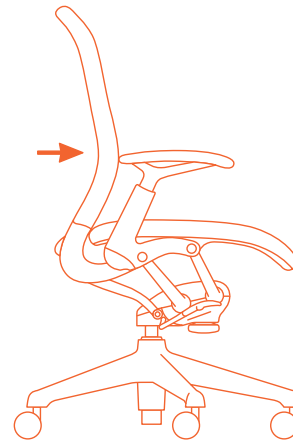
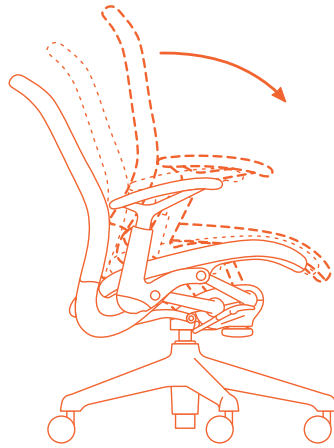
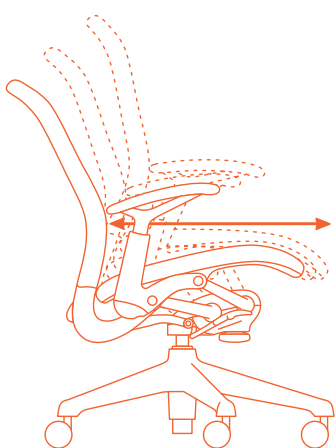

easy

**Minimal controls.
Maximum ease.**



Minimal Chadwick controls allow the user to adjust the chair with only a couple of effort-free adjustments.

Two Standard Chadwick Features

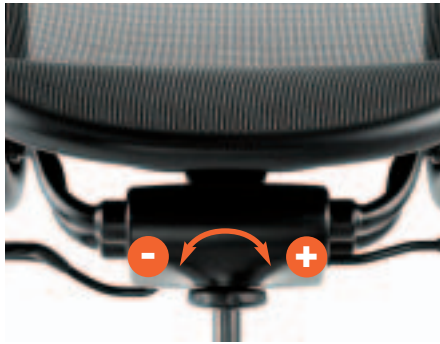

Tilt Tension (front view)



Seat Height

Three Optional Chadwick Adjustments



Tilt Stop



Adjustable Arms



Lumbar

Chadwick adjustments don't have to be learned. Minimal controls allow the user to adjust the chair to his or her body instantly with only a couple of effort-free adjustments.

Two Standard Chadwick Adjustments

1. Tilt Tension

The tension adjustment ensures each user customized comfort when reclining. The tension knob is formed from a soft molded material for a comfortable grip. To decrease the tension, turn the tension knob (while seated in the chair) clockwise, and turn it counterclockwise to increase the tension. There are approximately 17 turns of the knob from the loosest to the tightest position.

2. Seat Height

With a sculpted lever, the seat height adjustment is easy to find and operate. Like many chairs, Chadwick also has two other cylinder options, low and high, to meet the entire Business and Institutional Furniture Manufacturers' Association (BIFMA) range.

Three Optional Chadwick Adjustments

1. Tilt Stop Option

The tilt stop is an upright tilt limiter. When specified, it is the lever on the left side of the chair. The in-and-out lever design operates with an audible click so the user knows that the adjustment has been activated, whereby "in" is engaged, "out" is not engaged.

2. Arm Options: Adjustable, Fixed or Armless

Chadwick's exclusive adjustable arms are user-friendly and include height adjustability and arm-pad-width positioning. No lever is required to adjust the height. Simply move the arms up in five .5" increments for a total of 2.5". To lower the arms, lift them to the highest point and pull up firmly; they will return to the lowest point. The arm height adjustment is leverless and easy to maneuver with one hand.

The adjustable arms also have an optional tall version that gives 0.75" more height to the arm to meet the BIFMA tall end of the range. As with the seat height cylinder, BIFMA allows manufacturers to meet the specification with one or more arms.

The arm pads also include width adjustment. The arm is positioned with the arm stem centered on the 3-position pad. Using a 5/32" Allen wrench, the arm pads can be moved outboard .5" or inboard .5" from center for a total of 1".

3. Lumbar Option

Chadwick has an optional lumbar when needed. The patent-pending lumbar is cleverly designed to attach to the chair with magnets, making it simple to retrofit. The magnetic attachment also enables the lumbar numerous adjustability options. The pad is made of a soft thermoplastic elastomer and is amply shaped (11" x 4.25") for greater lumbar support area.

Note: Contains magnets. Consult the lumbar hangtag for more information.

Just Right.

With only two standard and three optional adjustments, Chadwick is easy to operate.

accessible

**Uncomplicated style,
true comfort and
functional scale.
All priced just right.**



Chadwick
is a Knoll design at
an accessible price.

Chadwick fits people.

Chadwick's dimensions are compliant with the industry standard of BIFMA G1-2002, a guideline that determines that the chair fits the fifth percentile female to the 95th percentile male, or 90% of the population.

The seat width, seat depth and back support offer ample interior dimensions, meeting most users' needs.

Chadwick fits into places.

Chadwick is scaled to fit a wide range of workspaces. The chair's footprint fits into workstations or desks and maximizes conference/training room capacity.

Knoll Workplace Research, 2004, shows that workstations are shrinking on average by 10% and, subsequently, chairs are becoming too large for the workspace. In addition, horizon lines in offices are getting lower: most are now 48". Chadwick stands at 41.8", offering ample back support while remaining appropriate in scale for the environment. Chadwick responds beautifully to these workplace trends with a compact exterior footprint and a maximum interior seating space.

Chadwick fits in.

With a palette of five colors ranging from warm to cool neutrals, Chadwick complements interiors and individual preferences.

The colors are:

- 01 Beige
- 02 Brown
- 03 Silver
- 04 Green
- 05 Black

Chadwick fits budgets.

Chadwick is a Knoll design at an accessible price. Chadwick is affordable, starting from \$705 list for the fixed arm basic chair to \$875 for the adjustable arm chair with the tilt stop option. (Note: the optional lumbar, if required, is \$55 list.)

Just Right.

Chadwick is both sensible and accessible.

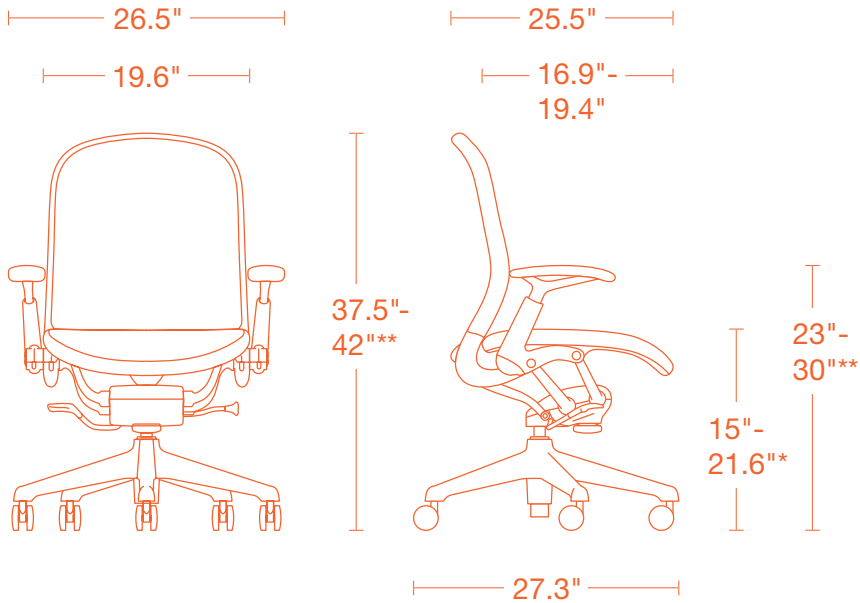

* range includes low, standard and high cylinders

** measurements taken using the standard height cylinder

01 Beige

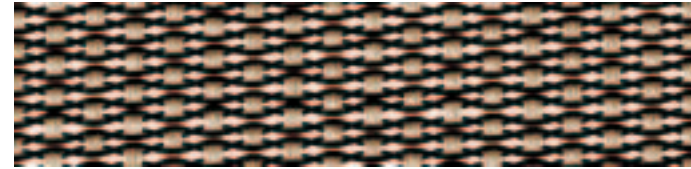

02 Brown

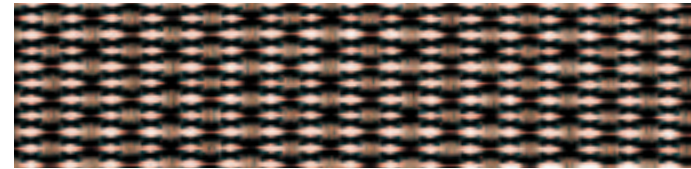

03 Silver

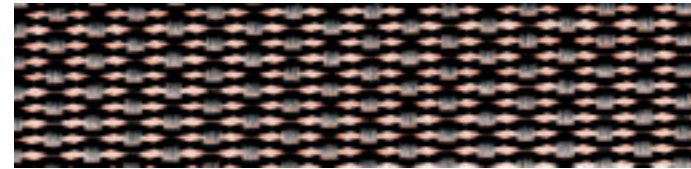

04 Green

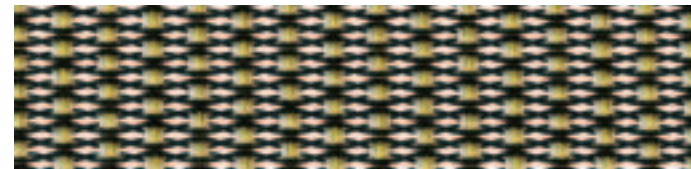

05 Black







just right

The right designer.

Don Chadwick is a world-renowned industrial designer whose sharp analysis of task seating has resulted in a new interpretation of the work chair.

The right partnership.

The right designer + Knoll.

The right aesthetic.

The Chadwick is handsomely athletic, trim and light.

The right comfort.

Chadwick has built-in comfort, including Active Suspension™

The right adjustments.

Chadwick performs more with less.
Fewer adjustments mean it's easier to use.

The right scale.

Chadwick fits the user and the workspace.

The right price.

Chadwick is accessible – a great value for the price.

more info





Don Chadwick
in his new studio, 2005.

Don Chadwick biography

Don Chadwick

No designer in the latter half of the 20th century has demonstrated more ingenuity or vision in office seating design than Don Chadwick. In the last few decades, Chadwick has pioneered the use of modern materials, molding processes and mechanisms, leading to cutting-edge products that have raised the standard for their markets.

A native of Southern California, Don Chadwick received his principal training in design at the University of California, Los Angeles. He then worked for architect Victor Gruen before establishing his own practice in 1964. In 1974, Chadwick designed Chadwick Modular Seating. Three years later, he and William Stumpf formed design studio Chadwick, Stumpf and Associates in Winona, Minnesota. Among others, the firm designed the Equa 1 flexing-plastic chair (1984), of which over 3 million were sold, and which *Time Magazine* recognized as Best Design of the Decade in 1990. Then, in 1994, the landmark Aeron® chair catapulted Chadwick to national attention; the Industrial Designers Society of America and *Business Week Magazine* awarded Design of the Decade to the Aeron chair in 1999. Chadwick has received numerous awards over the past three and a half decades.

Subsequently, Chadwick established Don Chadwick and Associates in Santa Monica, California. There, he has developed a strong interest in seating products for children, and recently he designed a children's desk chair for the Korea-based Hanssem Company.

Chadwick's relationship with Knoll marks a milestone in the career of an inventive designer. Commenting on his Knoll collaboration, he said: "Knoll has a recognizable and time-honored history of working with well-known and emerging designers. I am excited to be part of the Knoll legacy; I consider Knoll to be at the highest level of contemporary design, and our collaboration is a notable one for me."

"Throughout my career, I've been striving to scale down what a chair is about materially. This project enabled me to further explore that idea. I think the result is a chair that is very sympathetic to its ergonomic goals but manages to bridge issues of materials and technologies, allowing a solution that's light in scale. The chair's form has its own identity and personality, but I don't intend it to call great attention to itself as an object; it's intended to occupy a space *without* calling attention to itself.

"In the Knoll tradition of attention to materials and details, there is also an emphasis on the overall quality of form and function. The chair manifests itself in very honest visual cues that enable one to evaluate its structure."

The Chadwick chair is a natural progression of Don Chadwick's expression as a designer. It is the office chair refined – and redefined.

Awards

2000	Chicago Athenaeum, Good Design Award
1999	ISDA Design of the Decade, <i>Business Week Magazine</i>
1995	Furniture, Best of Category, <i>ID Magazine</i>
1995	Design Innovations 95, Design Zentrum, Germany
1992	First Place Award for Seating, Institute for Business Designers
1990	<i>Time Magazine</i> , January 1, 1990, Design: Best of Decade
1986	International Product Design Award, ASID
1985	Designs of the year, <i>ID Magazine</i>
1980	Silver Award for Casegoods, Institute of Business Designers
1977	The Governor's Award, Design Michigan
1974	First Place Award for Seating, Institute of Business Designers
1974	Award for Design Excellence, <i>ID Magazine</i>
1973	Award for Design Excellence, <i>ID Magazine</i>
1971	Award for Design Excellence, <i>ID Magazine</i>
1970	Award for Design Excellence, <i>ID Magazine</i>

Selected Group Exhibitions

2001	Workspheres, The Museum of Modern Art, New York
2000	Industrial Creativity & Design, Danish Design Center, Copenhagen
1997	Design Collection, The Museum of Fine Arts, Houston
1995	Design Collection, Denver Museum of Art, Colorado
1995	Common Forms, High Art: Three Centuries of American Furniture, LA County Museum of Art
1994	Design Collection, The Museum of Modern Art, New York
1991	1935-1965: What Modern Was, Los Angeles County Museum of Art
1985	High Styles: 20th Century American Design, Whitney Museum, New York
1984	A Serious Chair, Walker Art Center, Minneapolis, Minnesota
1976	California Design 12, Pacific Design Center, Los Angeles, California
1973	Contemporary Home Environs, La Jolla Museum of Contemporary Art, California
1971	California Design 11, Pasadena Museum of Art, California
1968	California Design 10, Pasadena Museum of Art, California

operating instructions

Synchronized Recline with Tilt Tension

Chadwick has a synchronized recline that allows the torso to open up while reclining. To customize the tension of the recline, adjust the tension knob. To decrease the tension, turn the tension knob clockwise (while seated in the chair), and turn it counterclockwise to increase the tension. The underside of the knob also indicates the instructions with arrows.

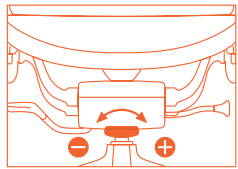

front view

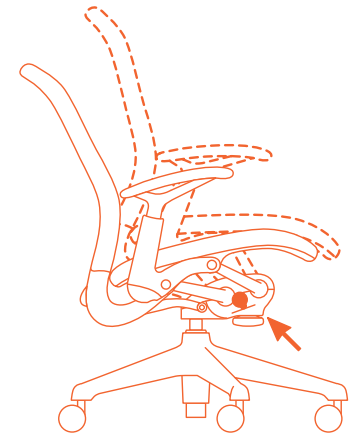
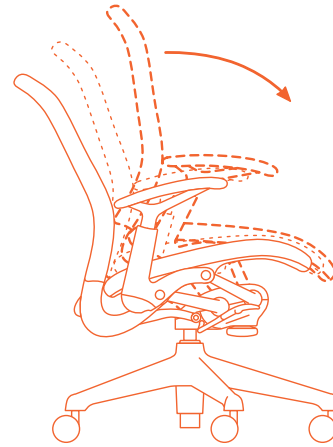
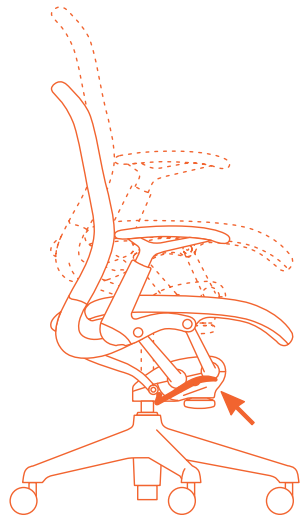
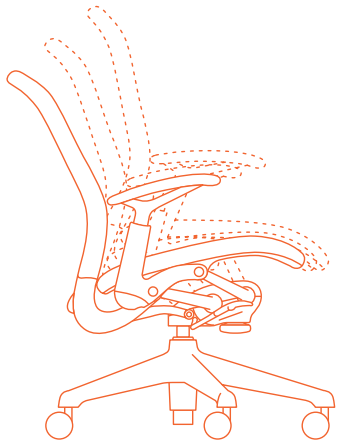

Seat Height Adjustment

To raise the seat height, remove your weight from the chair while lifting the lever on the right side of the chair. To lower the seat height, lift the lever while sitting in the chair.

Forward Tilt

Chadwick has a built-in forward tilt that automatically follows and supports the user in the forward posture for typing. No adjustment is required.

Tilt Stop (Optional)

The optional tilt stop is an upright tilt limiter. When specified, it is the lever on the left side of the chair. If your chair does not have a lever on the left side, it does not have tilt stop. The in-and-out lever design operates with an audible click, whereby “in” is engaged, “out” is not engaged.

Spring-Loaded Arms

Both fixed and adjustable armpads have a spring suspension, which provides the user with armpad softness and flexibility.

Adjustable Arm Height (Optional)

The optional arm height is adjusted by lifting the armpads upward. No lever is required. Simply move the arms up in five, .5" increments for a total of 2.5". To lower the arms, lift them to the highest point and at the highest point pull up firmly; and they will return to the lowest point. The arm height adjustment is easy to maneuver with one hand.

Adjustable Arm Width (Optional)

The armpads have an optional width adjustment of .5" inward or .5" outward for 1" in total adjustability on each side. A 5/32" allen wrench is required to adjust the armpad width.

Adjustable Lumbar (Optional)

Chadwick provides a generous built-in lumbar curve; however, if additional lumbar support is needed, there is an optional adjustable lumbar.

The optional adjustable lumbar is secured to the chair with magnets for easy installation and an infinite range of adjustability. Place the lumbar in the desired position on the chair and secure it by putting both halves together around the back suspension fabric of the chair.

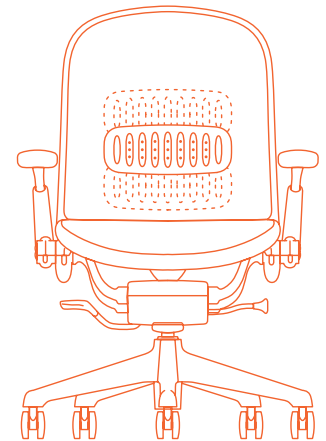
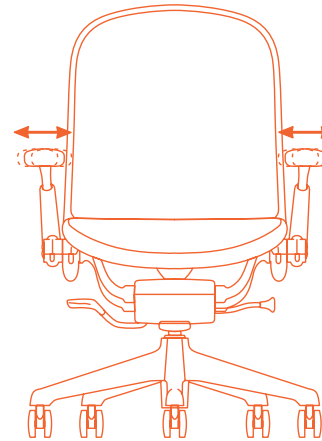
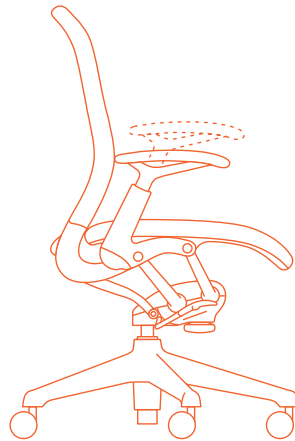
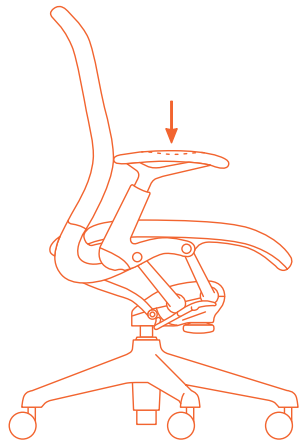

dimensions

	SEAT				BACK					ARMRESTS		
	Seat Height	Seat Depth	Seat Width	Step Pan Angle in Degrees	Backrest Height	Backrest Width	Lumbar Support Location	Angle between Seat and Back in Degrees	Tilt Range of Back	Armrest Height (fixed)	Armrest Height (adjustable)	Inside Distance between Armrests
Chadwick complies with the BIFMA G1-2002 Ergonomic Standard.												
BIFMA G1 Requirement	15.0" - 19.9" *	16.9" or less if fixed and must include 16.9" if adjustable	18.0" min.	0° - 4° **	12.2" min.	14.2" min.	5.9" - 9.8" ***	90° - 115°	10° min.	7.9" - 9.8"	6.9" - 10.8"	18.0" min.
Chadwick	15" - 21.6" *	16.9" in upright position 16.9" - 19.4" full range including the reclined position	19.6"	-5° - +7°	22.8"	18.5"	9" adjustable lumbar exceeds 5.9" - 9.9"	98.3°	29°	8.5"	6.9" - 9.4"(std.) 8.3" - 10.8"(tall arm)	18.5" - 20.5"

*Range achieved with single cylinder, or combination of cylinders. Chadwick standard cylinder is 15.9" - 20", high cylinder is 16.9" - 21.6", low cylinder is 15" - 19.1".



**Adjustable: Includes an angle of 0° to +4°

***Adjustable: Includes part of 5.9" - 9.8"

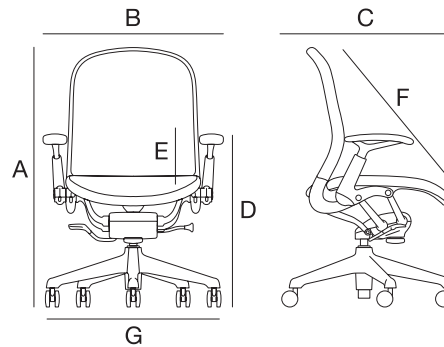
A overall height	37.5" - 42"
B overall width	26.5"
C overall depth	25.5"
D adj. arm height (from floor)	23" - 30"
fixed arm height (from floor)	25.3" - 29.8"
w/ standard cylinder	
E adj. arm height (from seat ref. point)	6.9" - 9.4" (std.) 8.3" - 10.8" (tall arm)
fixed arm height (from seat ref. point)	8.5"
F recline range/ratio seat: back	94° - 123°/1° : 1.2°
G base diameter	27.3"
weight	36 lbs.

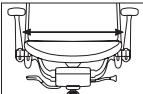
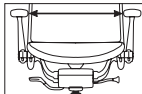

Chadwick Arm Options: All arms have soft armpads.

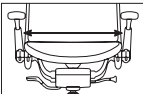
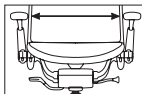
	Arm height (from the seat pan)	Distance between Arm supports	Distance between Armpads	Armpad Movement Width
Fixed Arms	8.5"	21" 	19.5" 	NA
Adjustable Arm (height and width adjustable)	6.9" - 9.4" (std.) 8.3" - 10.8" (tall arm) 	20.5" 	18.5" - 20.5" (inward to outward) 	1" per arm (2" total range)

Optional Adjustable Lumbar

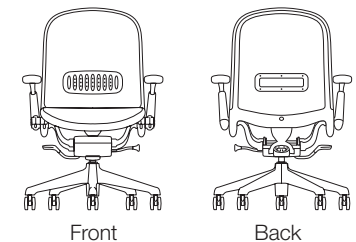

construction information

Back

<ul style="list-style-type: none">• Frame	Integrally-colored glass-filled nylon
<ul style="list-style-type: none">• Chadwick Fabric	100% polyester monofilament warp with multifilament fill fibers

Seat

<ul style="list-style-type: none">• Frame	Integrally-colored glass-filled nylon
<ul style="list-style-type: none">• Chadwick Fabric	100% polyester monofilament warp with multifilament fill fibers

Arms

<ul style="list-style-type: none">• Fixed/Adjustable Arm pads	Urethane armpad with flexible spring steel insert
<ul style="list-style-type: none">• Fixed/Adjustable Arm Supports	Integrally-colored glass-filled nylon

Base, Casters & Glides

<ul style="list-style-type: none">• Base	Integrally-colored glass-filled nylon
<ul style="list-style-type: none">• Casters and Glides	Integrally-colored nylon
<ul style="list-style-type: none">• Soft Casters	Integrally-colored thermoplastic urethane-covered nylon

Control

<ul style="list-style-type: none">• Housing	Aluminum casting and ABS (acrylonitrile butadiene styrene) top cover
<ul style="list-style-type: none">• Components	Steel, rubber and engineered plastics

Cylinder

<ul style="list-style-type: none">• Seat Height Cylinder	Pneumatic steel tubes containing nitrogen
--	---

Lumbar

<ul style="list-style-type: none">• Magnets	Neodymium
<ul style="list-style-type: none">• Carrier	Polypropylene
<ul style="list-style-type: none">• Pad and Frame	TPE (thermoplastic elastomer)

bid specification

Basic Adjustments

The chair must have the following basic adjustments:

- Translucent mesh or suspension seat and back upholstery
- Synchronized tilt mechanism with a 1: 1.2 degree ratio of seat to back recline
- Tilt-tension adjustment
- Pneumatic seat height adjustment with entire range of 15"-21.6"
- Forward tilt included in the recline/return range that does not require a knob to engage.
- Variable seat depth from 16.9"-19.4" during the recline
- All control levers must be within easy reach from the seated position in accordance with ADA standards

The following adjustments should be optional

- Upright tilt lock
- Adjustable lumbar with magnetic attachment. The lumbar must have unlimited adjustability and shall be user installable.
- Adjustable arms – Height adjustable arms with width adjustment capabilities. Arms must meet a height adjustment range of 3.9" with a single arm or with multiple arms. The arm pad width adjustment must be a 2" total range (1" per arm).
- Fixed arms
- Armless

Dimensions

Overall Height 37.5"- 42" (with standard cylinder)
Overall Width 26.5"
Overall Depth 26"
Seat Width 19.6"
Adjustable Arm Width 18.5"- 20.5"

Construction

The chair must adhere to the following construction guidelines

- The chair weight should not exceed 32 lbs.
- Seat and back mesh or suspension upholstery should be elastomeric monofilament with polyester monofilament yarns.
- Seat and back frame: Integrally colored, glass-filled reinforced nylon
- Base: Integrally colored glass-reinforced nylon

The following construction elements should be avoided

- Plywood or particle board materials
- Plastic-covered steel bases
- Glues and adhesives
- Polyvinyl chloride (PVC)

Warranty

The chair should have a 10-year, multi-shift warranty (24 hours/day, 7 days/week) for mesh or suspension fabric, pneumatics, controls or mechanisms, adjustable arms, casters and gliders, and structural elements. Labor should have a 3-year, multi-shift warranty.

Environmental

- Must be GREENGUARD™ compliant.
- Must be at least made from 41% recycled content
- Must have the ability to potentially contribute to 5 Commercial Interior LEED® credits, 3 potential Existing Building credits or 6 potential New Construction credits.
- The foam and glue should be free of chlorofluorocarbons (CFC's) and volatile organic compounds (VOC's) respectively.

Regulatory

- The chair should meet or exceed all ANSI/BIFMA guidelines for durability. The dimensional guidelines comply with the BIFMA G1-2002 guidelines.
- The chair must comply with California Technical Bulletin 133 (Cal133).

Assembly

The chair should ship fully assembled.

sustainable design/environment

Environmental aspects were incorporated into Chadwick early in the design process.

During the design process, Knoll conducted an analysis to ensure minimal negative environmental impact throughout the chair's life cycle. The result of this approach is a chair that uses minimum materials in its construction, clean manufacturing technologies such as integral coloring on plastic components, and zero VOC paints and adhesives.

Raw materials with a recycle content of 41% are used. The chair is designed for durability and ease of disassembly, such that worn parts can be removed and replaced effortlessly.

Goal and Scope

Chadwick was designed following the Knoll Product Environmental Design Guideline. The Environmental Design Guideline examines the various environmental impacts of a product. It explores the interrelationship of the various environmental impacts during the product's life cycle by examining each aspect to ensure that one environmental solution does not cause an environmental problem at another stage of the life cycle. For example, choosing a material that meets a durability requirement but is difficult to dispose of at the end of the life cycle may end up being a more negative environmental choice.

In order to make the right choices, the Environmental Design Guideline attempts to minimize environmental impacts across the product's life cycle. The result of this effort is Chadwick, that:

- Uses minimum types of materials in its construction
- Uses clean manufacturing technology such that no volatile organic carbon containing paints or adhesives are used
- Uses raw materials with a total recycled content of greater than 41%
- Is designed for durability and ease of disassembly
- Does not use toxic materials

Commercial Interiors

The sustainable design of the Chadwick Chair can help achieve the following commercial interiors LEED® credits:

MR Credit 3.3 30% Furniture and Furnishings

Intent: Reuse building and materials in order to reduce demand for virgin materials and reduce waste, thereby reducing impacts associated with the extraction and processing of virgin resources.

The Chadwick chair is designed to be refurbished for a second life and could be used in a future LEED® project.

MR Credit 4.1 Recycled Content 10% (Post-consumer + Post-industrial)

Intent: Increase demand for building products that incorporate recycled material, reducing impacts resulting from extraction and processing of virgin materials.

The Chadwick chair has a recycled content of more than 41%.

MR Credit 4.2 Recycled Content 20% (Post-consumer + Post-industrial)

Intent: Increase demand for building products that incorporate recycled material, reducing impacts resulting from extraction and processing of virgin materials.

The Chadwick chair has a recycled content of more than 41%.

MR Credit 5.1 Regional Materials

Intent: Increase the demand for building materials and products that are extracted and manufactured within the region.

Help with this point will depend on project location.

EQ Credit 4.5 Low-Emitting Materials, Furniture and Furnishings

Intent: Reduce the use of furniture assemblies that may release indoor air contaminants that are odorous or potentially irritating and might be deleterious to installer and occupant health, comfort and well-being.

The Chadwick chair is GREENGUARD™ certified.

Existing Building

The sustainable design of the Chadwick chair can help achieve the following existing building LEED® credits:

MR Credit 2.1 – 2.5 Optimize Use of Alternative Materials

Intent: Reduce the environmental impacts of the materials acquired for use in the operations and maintenance of buildings and in the upgrading of building services.

The Chadwick chair can help in the following areas:

- Contains at least 10% post-consumer or 20% post-industrial material.
- Has a recycled content of more than 41%.

MR Credit 4.0 Sustainable Cleaning Products and Materials

Intent: Avoid exposure of building occupants and maintenance personnel to potentially hazardous chemical, biological and particle contaminants, which adversely impact air quality, health, building finishes and systems, and the environment.

The Chadwick chair is designed to be cleaned with low environmental impact cleaning fluids.

IR Credit Innovation Credit

The Chadwick chair is GREENGUARD™ certified. GREENGUARD™ certification may help obtain an innovation credit.

New Construction

The sustainable design of the Chadwick chair can help achieve the following new construction LEED® credits:

MR Credit 3.1 Resource Reuse 5%

Intent: Reuse building and materials in order to reduce demand for virgin materials and reduce waste, thereby reducing impacts associated with the extraction and processing of virgin resources.

The Chadwick chair is designed to be refurbished for a second life and could be used in a future LEED® project.

MR Credit 3.2 Resource Reuse 10%

Intent: Reuse building and materials in order to reduce demand for virgin materials and reduce waste, thereby reducing impacts associated with the extraction and processing of virgin resources.

The Chadwick chair is designed to be refurbished for a second life and could be used in a future LEED® project.

MR Credit 4.1 Recycled Content 5% (Post-consumer + Post-industrial)

Intent: Increase demand for building products that incorporate recycled material, reducing impacts resulting from extraction and processing of virgin materials.

The Chadwick chair has a recycled content of more than 41%.

MR Credit 4.2 Recycled Content 10% (Post-consumer + Post-industrial)

Intent: Increase demand for building products that incorporate recycled material, reducing impacts resulting from extraction and processing of virgin materials.

The Chadwick chair has a recycled content of more than 41%.

MR Credit 5.1 Regional Materials

Intent: Increase the demand for building materials and products that are extracted and manufactured within the region.

Help with this point will depend on project location.

IR Credit Innovation Credit

The Chadwick chair is GREENGUARD™ certified. GREENGUARD™ certification may help obtain an innovation credit.

notes

Knoll®

knoll.com

Printed in Canada on paper that contains 50% recycled content including 15% post consumer waste.

PG-CHAD05

© 2005 Knoll, Inc. All rights reserved.